

Utility Scale Solar Power Plants

A GUIDE FOR DEVELOPERS AND INVESTORS



This document was written for the International Finance Corporation (IFC) by Alasdair Miller and Ben Lumby of Sgurr Energy Limited. The project was implemented in partnership with The Global Environment Facility (GEF) and the Austrian Ministry of Finance.

February 2012

Solar energy technology is gaining swift acceptance.

India is well-placed to benefit from the successful development of the solar energy industry. It is hoped that this guidebook will encourage project developers and financiers in India and elsewhere to adopt industry best practices in the development, construction, operation and financing of solar projects.

This guidebook is a best practice manual for utility-scale solar power plants in India. It focuses primarily on ground mounted, fixed tilt PV projects and also covers solar tracking system technology. Intended to be a practical toolkit, the guidebook includes an annex that covers Concentrated Solar Power (CSP) technology and highlights aspects of the CSP project development process that differ from the PV equivalent. It also has annexes on construction, operation and maintenance contract terms.

While the guidebook is focused on utility-scale, grid-connected solar projects, much of the technical content is equally relevant to off-grid solar applications and is likely to be helpful to readers keen to deepen their understanding of this exciting sector.

To illustrate various aspects of project development, construction and operation, a number of case studies have been included. All case studies are based on the same project: a real 5MWp, thin film plant situated in India. The following section summarizes the various aspects in the process of development, operation and financing of utility scale solar power plants in India. Each topic is covered in detail in this book.

We hope that you find this guidebook useful.



Anita Marangoly George
Director
Infrastructure & Natural Resource, Asia

Solar PV Technology

The applications of solar PV power systems can be split into four main categories: off-grid domestic; off-grid non-domestic; grid-connected distributed; and grid-connected centralised. This guidebook is focussed on grid-connected centralised applications.

The main components of a PV power plant are PV modules, mounting (or tracking) systems, inverters, transformers and the grid connection.

Solar PV modules are made up of PV cells, which are most commonly manufactured from silicon but other materials are available. Cells can be based on either wafers (manufactured by cutting wafers from a solid ingot block of material) or “thin film” deposition of material over low cost substrates. In general, silicon-based crystalline wafers provide high efficiency solar cells but are relatively costly to manufacture, whereas thin film cells provide a cheaper alternative but are less efficient.

Since different types of PV modules have different characteristics (in terms of efficiency, cost, performance in low irradiation levels, degradation rate), no single type is preferable for all projects. In general, good quality PV modules are expected to have a useful life of 25 to 30 years, although their performance will steadily degrade over this period.

The PV module market is dominated by a few large manufacturers based predominantly in Europe, North America and China. Selecting the correct module is of fundamental importance to a PV project, keeping in mind the numerous internationally accepted standards. When assessing the quality of a module for any specific project, it is important to assess its specifications, certifications and performance record besides the track record of the manufacturer.

PV modules must be mounted on a structure. This helps to keep them oriented in the correct direction and provides them with structural support and protection.

Mounting structures may be either fixed or tracking. Since fixed tilt mounting systems are simpler, cheaper and have lower maintenance requirements than tracking systems, they are the preferred option for countries with a nascent solar market and with limited indigenous manufacturers of tracking technology (such as India). Although tracking systems are more expensive and more complex, they can be cost-effective in locations with a high proportion of direct irradiation.

PV modules are generally connected together in series to produce strings of modules of a higher voltage. These strings may then be connected together in parallel to produce a higher current DC input to the inverters.

Inverters are solid state electronic devices that convert DC electricity generated by the PV modules into AC electricity, suitable for supply to the grid. In addition, inverters can also perform a range of functions to maximise the output of a PV plant.

In general, there are two main classes of inverters: central inverters and string inverters. Central inverters are connected to a number of parallel strings of modules. String inverters are connected to one or more series strings. While numerous string inverters are required for a large plant, individual inverters are smaller and more easily maintained than a central inverter.

While central inverters remain the configuration of choice for most utility-scale PV projects, both configurations have their pros and cons. Central inverters offer high reliability and ease of installation. String inverters, on the other hand, are cheaper to manufacture, simpler to maintain and can give enhanced power plant performance on some sites.

The efficiency of proposed inverters should be carefully considered during the development process. While there is no universally accepted method for quantifying inverter efficiency, there are a number of established methods that can help in making an informed decision. Almost half of the inverter market is dominated by SMA Solar Technology AG, which has a higher market share than the combined share of the next four largest vendors. Following a global shortage of inverters in 2010, some big name players are starting to enter the solar inverter market. A key parameter is the Performance Ratio (PR) of a PV power plant, which quantifies the overall effect of losses on the rated output. The PR, usually expressed as a percentage, can be used to compare PV systems independent of size and solar resource. A PR varying from approximately 77% in summer to 82% in winter (with an annual average PR of 80%) would not be unusual for a well-designed solar PV installation or plant, depending on the ambient conditions.

It is also important to consider the capacity factor of a PV power plant. This factor (usually expressed as a percentage) is the ratio of the actual output over a period of a year to theoretical output if the plant had operated at nominal power for the entire year. The capacity factor of a fixed tilt PV plant in southern Spain will typically be in the region of 16%. Plants in India operating within a reliable grid network are expected to have a similar capacity factor.

This apart, the “specific yield” (the total annual energy generated per kWp installed) is often used to help determine the financial value of a plant and compare operating results from different technologies and systems.

Solar Resource

Reliable solar resource data are essential for the development of a solar PV project. While these data at a site can be defined in different ways, the Global Horizontal Irradiation (the total solar energy received on a unit area of horizontal surface) is generally of most interest to developers. In particular, a high long term average annual GHI is desired.

There are two main sources of solar resource data: satellite derived data and land-based measurement. Since both sources have particular merits, the choice will depend on the specific site. Land based site measurement can be used to calibrate resource data from other sources (satellites or meteorological stations) in order to improve accuracy and certainty.

As solar resource is inherently intermittent, an understanding of inter-annual variability is important. At least 10 years of data are usually required to give the variation to a reasonable degree of confidence.

In India, solar resource data are available from various sources. These include the Indian Meteorological Department, NASA's Surface Meteorology and Solar Energy data set, METEONORM's global climatological database, and satellite-derived geospatial solar data products from the United States National Renewable Energy Laboratory. These sources are of varying quality and resolution. Appropriate expertise is needed to interpret the data.

Project Development

The development of a PV project can be broken down into the following phases: conceptual, pre-feasibility study, feasibility study, development and design. In general, each succeeding phase entails an increased level of expenditure but reduces the risk and uncertainty in the project. In practice, the progression through these phases is not strictly linear. The amount of time and money committed in each phase will vary, depending on the priorities and risk appetite of the developer.

A typical scope for a feasibility study would include the items below (again, these are covered in more detail in the book):

- Production of a detailed site plan.
- Calculation of solar resource and environmental characteristics.
- Assessment of shading (horizon and nearby buildings and objects).
- Outline layout of areas suitable for PV development.
- Assessment of technology options providing cost/benefit for the project location:
 - Module type.
 - Mounting system.
- Outline system design.
- Application for outline planning permission.
- Grid connection – more detailed assessment of likelihood, cost and timing.
- Predicted energy yields.
- Financial modelling.

The development phase takes the project from the feasibility stage through to financial close and is likely to consist of:

- Preparation and submission of the permit applications for the proposed solar PV project.
- Preparation and submission of a grid connection application.
- Revision of the design and planning permissions.
- Decision on contracting strategy (turnkey EPC contract or multi- contract).
- Decision on the financing approach.
- Preparation of solar PV module tender documentation.
- Supplier selection and ranking.
- Preparation of construction tender documentation.
- Contractor selection and ranking.
- Contract negotiations.
- Completion of a bankable energy yield.
- Preparation of a financial model covering the full life cycle of the plant.
- Completion of a project risk analysis.
- Environmental impact assessment.
- Production of a detailed project report.
- Securing financing for the project.

The design phase will prepare the necessary detail and documentation to enable the tendering and construction of the solar PV plant.

Site Selection

Selecting a suitable site is a crucial part of developing a viable solar PV project. In selecting a site, the aim is to maximise output and minimise cost. The main constraints that need to be assessed include:

- **Solar resource** – Global Horizontal Irradiation, annual and inter-annual variation, impact of shading.
- **Local climate** – flooding, high winds, snow and extreme temperatures.
- **Available area** – area required for different module technologies, access requirements, pitch angle and minimising inter-row shading.
- **Land use** – this will impact land cost and environmental sensitivity. The impact of other land users on the site should also be considered.
- **Topography** – flat or slightly south facing slopes are preferable for projects in the northern hemisphere.
- **Geotechnical** – including consideration of groundwater, resistivity, load bearing properties, soil pH levels and seismic risk.
- **Geopolitical** – sensitive military zones should be avoided.
- **Accessibility** – proximity to existing roads, extent of new roads required.
- **Grid connection** – cost, timescales, capacity, proximity and availability.
- **Module soiling** – including local weather, environmental, human and wildlife factors.
- **Water availability** – a reliable supply is required for module cleaning.
- **Financial incentives** – tariffs and other incentives vary between countries and regions within countries.

Energy Yield Prediction

The energy yield prediction provides the basis for calculating project revenue. The aim is to predict the average annual energy output for the lifetime of the proposed power plant (along with the confidence levels). The level of accuracy required will depend on the stage of development of the project.

To estimate accurately the energy produced from a PV power plant, information is needed on the solar resource and temperature conditions of the site. Also required are the layout and technical specifications of the plant components.

To make life easy for project developers, a number of solar energy yield prediction software packages are available in the market. These packages use time step simulation to model the performance of a project over the course of a year. To ensure more accurate results that would satisfy a financial institution's due diligence and make the project bankable, the analysis should be carried out by a qualified expert. Realistic allowance should be made for undermining factors such as air pollution, grid downtime and electrical losses.

Annual energy yields may be expressed within a given confidence interval (for example, the P90 annual energy yield prediction means the energy yield value with a 90% probability of exceedance). Since the energy yield simulation software is heavily dependent on the input variables, any uncertainty in the resource data gets translated into uncertainty in the yield prediction results. As the energy yield depends linearly, to a first approximation, on the plane of array irradiance it is the uncertainty in the resource data that dominates the uncertainty in the yield prediction.

Plant Design

The design of a PV plant involves a series of compromises aimed at achieving the lowest possible levelised cost^[1] of electricity. Choosing the correct technology (especially modules and inverters) is of central importance. Selecting a module requires assessment of a complex range of variables. At the very least, this assessment would include cost, power output, benefits / drawbacks of technology type, quality, spectral response, performance in low light, nominal power tolerance levels, degradation rate and warranty terms.

The factors to consider when selecting inverters include compatibility with module technology, compliance with grid code and other applicable regulations, inverter-based layout, reliability, system availability, serviceability, modularity, telemetry requirements, inverter locations, quality and cost.

In designing the site layout, the following aspects are important:

- Choosing row spacing to reduce inter-row shading and associated shading losses.
- Choosing the layout to minimise cable runs and associated electrical losses.
- Allowing sufficient distance between rows to allow access for maintenance purposes.
- Choosing a tilt angle that optimises the annual energy yield according to the latitude of the site and the annual distribution of solar resource.
- Orientating the modules to face a direction that yields the maximum annual revenue from power production. In the northern hemisphere, this will usually be true south.

The electrical design of a PV project can be split into the DC and AC systems. The DC system comprises the following:

- Array(s) of PV modules.
- Inverters.
- DC cabling (module, string and main cable).
- DC connectors (plugs and sockets).
- Junction boxes/combiners.
- Disconnects/switches.
- Protection devices.
- Earthing.

The AC system includes:

- AC cabling.
- Switchgear.
- Transformers.
- Substation.
- Earthing and surge protection.

Every aspect of both the DC and AC electrical systems should be scrutinised and optimised. The potential economic gains from such an analysis are much larger than the cost of carrying it out.

In order to achieve a high performance PV plant, the incorporation of automatic data acquisition and monitoring technology is essential. This allows the yield of the plant to be monitored and compared with calculations made from solar irradiation data to raise warnings on a daily basis if there is a shortfall. Faults can then be detected and rectified before they have an appreciable effect on production.

[1] Levelised cost is the net cost to install and operate a renewable energy system divided by its expected life-time energy output.

In addition, power plants typically need to provide 24-hour forecasts (in half hourly time steps) to the network operator. These forecasts help network operators to ensure continuity of supply.

Selection of suitable technology and optimisation of the main electrical systems is clearly vital. Alongside, detailed consideration should be given to the surrounding infrastructure, including the mounting structures, control building, access roads and site security systems. While these systems should be relatively straightforward to design and construct, errors in these systems can have a disproportionate impact on the project.

Permits and Licensing

Permit and licensing requirements vary, depending on the location of the project but the key permits, licences and agreements typically required for renewable energy projects include:

- Land lease contract.
- Environmental impact assessment.
- Building permit/planning consent.
- Grid connection contract.
- Power purchase agreement.

The authorities, statutory bodies and stakeholders that should be consulted also vary from country to country but will usually include the following organisation types:

- Local and/or regional planning authority.
- Environmental agencies/departments.
- Archaeological agencies/departments.
- Civil aviation authorities (if located near an airport).

- Local communities.
- Health and safety agencies/departments.
- Electricity utilities.
- Military authorities.

Early engagement with all relevant authorities is highly advisable to minimise risk and maximise the chances of successful and timely implementation of the project.

Construction

The management of the construction phase of a solar PV project should be in accordance with construction management best practice. The aim should be to construct the project to the required level of quality within the time and cost deadlines.

During construction, the environmental impact of the project as well as the health and safety issues of the workforce (and other affected people) should also be carefully managed. The IFC Performance Standards give detailed guidance on these issues. Compliance with these standards can facilitate the financing of a project.

Typical issues that arise during the construction of a PV project include:

- Foundations not being suited to ground conditions.
- Discovery of hazardous / contaminated substances during excavation.
- Incorrect orientation of modules.
- Insufficient cross-bracing on mounting structures.
- Incorrect use of torque wrenches.
- Damaging cables during construction / installation.

- Delayed grid connection.
- Access / construction constrained by weather.
- Insufficient clearance between rows for vehicle access.

While some of these issues appear minor, rectification of the problems they cause can be expensive. While close supervision of contractors during construction is important, using the services of a suitably experienced engineer should be considered if the required expertise is not available in-house.

Commissioning

Commissioning should prove three main criteria:

- The power plant is structurally and electrically safe.
- The power plant is sufficiently robust (structurally and electrically) to operate for the specified project lifetime.
- The power plant operates as designed and performs as expected.

Commissioning tests are normally split into three groups:

- Visual acceptance tests. These tests take place before any systems are energised and consist of a detailed visual inspection of all significant aspects of the plant.
- **Pre-connection acceptance tests.** These include an open circuit voltage test and short circuit current test. These tests must take place before grid connection.
- **Post-connection acceptance test.** Once the plant is connected to the grid, a DC current test should be carried out. Thereafter, the performance ratio of the plant is measured and compared with the value stated in the contract. An availability test, usually over a period of 5 days, should also be carried out.

Operations and Maintenance

Compared to most other power generating technologies, PV plants have low maintenance and servicing requirements. However, suitable maintenance of a PV plant is essential to optimise energy yield and maximise the life of the system.

Maintenance consists of:

- **Scheduled or preventative maintenance** – planned in advance and aimed to prevent faults from occurring, as well as to keep the plant operating at its optimum level.
- **Unscheduled maintenance** – carried out in response to failures.

Scheduled maintenance typically includes:

- Module cleaning.
- Checking module connection integrity.
- Checking junction / string combiner boxes.
- Thermographic detection of faults.
- Inverter servicing.
- Inspecting mechanical integrity of mounting structures.
- Vegetation control.
- Routine balance of plant servicing / inspection.

Common unscheduled maintenance requirements include:

- Tightening cable connections that have loosened.
- Replacing blown fuses.
- Repairing lightning damage.
- Repairing equipment damaged by intruders or during module cleaning.
- Rectifying supervisory control and data acquisition (SCADA) faults.

- Repairing mounting structure faults.
- Rectifying tracking system faults.

Careful consideration should be given to selecting an operation and maintenance (O&M) contractor and drafting the O&M contract to ensure that the performance of the plant is optimised. After the project is commissioned, it is normal for the EPC contractor to guarantee the performance ratio and the O&M contractor to confirm the availability and, ideally, the performance ratio.

Economics and Financial Modeling

The development of solar PV projects can bring a range of economic costs and benefits at the local and national levels. Economic benefits can include:

- Job creation.
- Use of barren land.
- Avoidance of carbon dioxide emissions.
- Increased energy security.
- Reduction of dependence on imports.
- Increased tax revenue.

An awareness of the possible economic benefits and costs will aid developers and investors in making the case for developing solar energy projects to local communities and government bodies.

India's Central Electricity Regulatory Commission (CERC) has produced a benchmark capital cost of INR 169 million/

MWp for solar PV power projects commissioned during fiscal years 2010/11 and 2011/12. The CERC benchmark also gives a breakdown of the various cost elements that can be used by developers for planning or comparison purposes.

The financial benefits and drawbacks to the developer should be explored in detail through the development of a full financial model. This model should include the following inputs:

- **Capital costs** – these should be broken down as far as possible. Initially, the CERC assumption can be used but quoted prices should be included when possible.
- **Operations and maintenance costs** – in addition to the predicted O&M contract price, operational expenditure will include comprehensive insurance, administration costs, salaries and labour wages.
- **Annual energy yield** – as accurate an estimate as is available at the time.
- **Energy price** – this can be fixed or variable and will depend on the location of the project as well as the tariff under which it has been developed.
- **Certified Emission Reductions** – under the Clean Development Mechanism, qualifying Indian solar projects may generate Certified Emission Reductions, which can then be sold. However, this revenue is difficult to predict.
- **Financing assumptions** – including proportion of debt and equity, interest rates and debt terms.
- **Sensitivity analysis** – sensitivity of the energy price to changes in the various input parameters should be assessed.

Financing PV Projects

Solar PV projects are generally financed on a project finance basis. As such, the equity partners and project finance partners typically conduct an evaluation of the project covering the legal aspects, permits, contracts (EPC and O&M), and specific technical issues prior to achieving financial closure. The project evaluations (due diligence) identify the risks and methods of mitigating them prior to investment.

There are typically three main due diligence evaluations:

- **Legal due diligence** – assessing the permits and contracts (EPC and O&M).
- **Insurance due diligence** – assessing the adequacy of the insurance policies and gaps in cover.
- **Technical due diligence** – assessing technical aspects of the permits and contracts. These include:
 - Sizing of the PV plant.
 - Layout of the PV modules, mounting and/or trackers, and inverters.
 - Electrical design layout and sizing.
 - Technology review of major components (modules/inverters/mounting or trackers).
 - Energy yield assessments.
 - Contract assessments (EPC, O&M, grid connection, power purchase and Feed-in Tariff (FiT) regulations).
 - Financial model assumptions.

In Europe, it is quite normal to see the equity partners and developers form a special purpose vehicle (SPV) to develop the project. The equity component is typically around 15-20% of the total project investment cost. The debt portion—usually provided by an investment bank offering project finance or leasing finance—is typically 80-85% of the total project investment cost.

Despite the recent turmoil in the international credit markets, many financial institutions are willing to provide long term finance for the solar energy sector. Individual projects from smaller developers may receive financing with a loan to value (LTV) ratio of 80%, whereas portfolios of solar power projects from experienced developers may be financed with a LTV ratio of 85%. Typical terms of the project finance loan are approximately 18 years. In India, a debt-equity split of 75:25 is taken as standard and the debt term is typically around 14 years.

At present, the insurance industry has not standardised the insurance products for PV projects or components. However, an increasing demand for PV insurance is expected to usher in standardisation. In general, while large PV systems require liability and property insurance, many developers may also opt to add policies such as environmental risk insurance.

Conclusion

Solar power is becoming a widely accepted technology. India is well-placed to benefit from the successful development of a solar energy industry. It is hoped that this guidebook will encourage Indian project developers and financiers to adopt industry best practices in the development, construction, operation and financing of solar projects.

Contents

1 INTRODUCTION	23
2 SOLAR PV TECHNOLOGY	24
2.1 Applications of Solar PV	24
2.2 Overview of Ground Mounted PV Power Plant	24
2.3 Solar PV Modules.....	24
2.4 Mounting and Tracking Systems	31
2.5 Inverters	34
2.6 Quantifying Plant Performance	39
2.7 Solar PV Technology Conclusions.....	41
3 THE SOLAR RESOURCE.....	42
3.1 Quantifying the Resource	42
3.2 Solar Resource Assessment.....	42
3.3 Variability in Solar Irradiation	44
3.4 Indian Solar Resource	44
4 PROJECT DEVELOPMENT.....	50
4.1 Overview of Project Phases.....	50
4.2 Concept	50
4.3 Pre-Feasibility Study.....	50
4.4 Feasibility Study.....	51
4.5 Development	52
4.6 Detailed Design	55
5 SITE SELECTION	55
5.1 Introduction	55
5.2 Site Selection Constraints	56
6 ENERGY YIELD PREDICTION.....	60
6.1 Irradiation on Module Plane.....	60
6.2 Performance Modelling	61
6.3 Energy Yield Prediction Results.....	61
6.4 Uncertainty in the Energy Yield Prediction.....	61

Contents

7 PLANT DESIGN	68
7.1 Technology Selection	68
7.2 Layout and Shading.....	74
7.3 Electrical Design.....	77
7.4 Infrastructure	92
7.5 Site Security.....	93
7.6 Monitoring and Forecasting	94
7.7 Optimising System Design.....	98
7.8 Design Documentation Requirements.....	100
7.9 Plant Design Conclusions.....	102
8 PERMITS AND LICENSING	105
8.1 Permitting, Licensing and Regulatory Requirements – General	105
8.2 IFC Performance Standards On Social And Environmental Sustainability	105
8.3 Permitting, Licensing and Regulatory Requirements – India.....	106
9 CONSTRUCTION	110
9.1 Introduction	110
9.2 Interface Management	110
9.3 Programme and Scheduling	110
9.4 Cost Management	113
9.5 Contractor Warranties.....	115
9.6 Quality Management	116
9.7 Environmental Management.....	116
9.8 Health and Safety Management	117
9.9 Specific Solar PV Construction Issues	117
9.10 Construction Supervision	119
10 COMMISSIONING	122
10.1 General Recommendations	123
10.2 Pre-Connection Acceptance Testing	123
10.3 Grid Connection.....	123
10.4 Post Connection Acceptance Testing	124
10.5 Provisional Acceptance.....	124
10.6 Handover Documentation	125

Contents

11 OPERATION AND MAINTENANCE	126
11.1 Scheduled/Preventative Maintenance.....	126
11.2 Unscheduled Maintenance.....	128
11.3 Spares.....	129
11.4 Performance Monitoring, Evaluation and Optimisation	129
11.5 Contracts.....	129
11.6 Operations and Maintenance Conclusions	133
12 ECONOMICS AND FINANCIAL MODEL	134
12.1 Economic Benefits and Costs	134
12.2 Central Electricity Regulatory Commission (CERC) Cost Benchmarks.....	136
12.3 Financial Model.....	137
13 FINANCING PV PROJECTS.....	144
13.1 Introduction	144
13.2 Project Financing	144
13.3 Risks	146
13.4 Insurance	149
14 CONCLUSION	150
Appendix A – Concentrated Solar Power	
1 INTRODUCTION	151
2 Installed CSP Capacity	152
3 THE SOLAR RESOURCE.....	152
4 Review of CSP Technologies.....	152
4.1 Overview of Concentrating Solar Thermal Technologies	154
4.1.1 Uptake and Track Record.....	156
4.1.2 CSP Cost Trends.....	156
4.1.3 Summary Comparison	158
4.2 Parabolic Trough Concentrators.....	158
4.2.1 Reflector	160
4.2.2 Receiver Tube.....	161
4.2.3 Heat Transfer Fluid	161
4.2.4 Base Frame, Tracking System and Connecting Elements	162

Contents

4.2.5 Examples from Industry.....	162
4.2.6 Losses.....	163
4.2.7 Costs	164
4.2.8 Conclusions	165
4.3 Power Tower	166
4.3.1 Heliostat and the Tracking and Control Mechanisms.....	166
4.3.2 Receiver, Heat Transfer Medium and Tower	167
4.3.3 Examples in Industry.....	167
4.3.4 Conclusions	168
4.4 Parabolic Dish	169
4.4.1 Stirling Engines	169
4.4.2 Conclusions	170
4.5 Power Block	170
4.6 Energy Storage and Supplementary Heating.....	171
4.6.1 Overview	171
4.6.2 Storage Medium (Including Molten Salts).....	172
4.6.3 Supplementary Heating (Use of Natural Gas or LPG).....	172
4.6.4 Costs	172
4.6.5 Conclusions	173
4.7 Cooling and Water Consumption.....	173
4.7.1 Cooling Options	173
4.7.2 Water Consumption	174
4.8 Integrated Solar Combined Cycle.....	175
4.9 Concentrated Photovoltaic (CPV).....	176
4.9.1 Manufacturers and Examples from Industry.....	176
4.9.2 CPV Advantages and Disadvantages	177
4.10 Linear Fresnel Reflector.....	177
4.10.1 Applications and Examples	177
4.10.2 Reflector and Structure.....	178
4.10.3 Receiver and Heat Transfer.....	179
4.10.4 Conclusions.....	179

Contents

5 Site Selection	180
6 Energy Yield Prediction	180
6.1 Site Conditions and Data Measurements.....	180
6.2 Technology Characteristics	181
6.3 Energy Yield Modelling	181
7 Project Implementation	182
7.1 Overview.....	182
7.2 Design	182
7.2.1 Project Size and Land Area	182
7.2.2 Load Matching Generation.....	182
7.2.3 Solar Multiple.....	182
7.2.4 Capacity Factor	182
7.2.5 Grade of Heat	183
7.3 Development.....	183
7.4 Engineering, Procurement and Construction.....	184
7.5 Uncertainties and Risks	184
7.5.1 Achieving Performance Improvements	184
7.5.2 Realising Learning Rate Effects	184
7.5.3 Supply Chain Competition	185
7.5.4 Short Term Cost Uncertainties.....	185
8 Conclusion	185
Appendix A – Concentrated Solar Power	151
Appendix B – AC Benchmarks.....	186
Appendix C – EPC Contract Model Heads of Terms	188
Appendix D – O&M Contract Model Heads of Terms	195

Contents

LIST OF FIGURES AND TABLES

FIGURES

Figure 1: Overview of Solar PV Power Plant.....	25
Figure 2 (a): PV Technology Classes.....	26
Figure 2 (b): Development of Research Cell Efficiencies.....	30
Figure 3: Effect of Tilt on Solar Energy Capture	31
Figure 4: Benefit of Dual Axis Tracking System.....	32
Figure 5: An Example of a Tracking PV Plant	33
Figure 6: PV System Configurations	35
Figure 7: Transformer and Transformerless Inverter Schematic.....	36
Figure 8: Efficiency Curves of Low, Medium and High Efficiency Inverters as Functions of the Input Power to Inverter Rated Capacity Ratios	37
Figure 9: Inverter Manufacturer Market Share 2009.....	39
Figure 10: Annual Average Global Horizontal Irradiation	43
Figure 11: Example Pyranometer Measuring GHI (Image courtesy: Kipp & Zonen)	43
Figure 12: Annual Average Daily Global Horizontal Irradiation for India at 40-km Resolution.	45
Figure 13: Annual Mean Horizontal Solar Irradiation for Three Cities in India	46
Figure 14: Monthly Diffuse and Direct Solar Irradiation in Chennai, India	47
Figure 15: Large Scale PV Plant.....	57
Figure 16: Uncertainty in Energy Yield Prediction.....	65
Figure 17: Sun-path Diagram for Chennai, India.....	75
Figure 18: Shading Angle Diagram (Image courtesy of Schletter GmbH).....	76
Figure 19: Voltage and Power Dependency Graphs of Inverter Efficiency.....	79
Figure 20: PV Array Showing String Cables	82
Figure 21: Typical Transformer Locations and Voltage Levels in a Solar Plant where Export to Grid is at HV	89
Figure 22: PV System Monitoring Schematic	95
Figure 23: Components of a Forecasting System	97
Figure 24: Spacing Between Module Rows	119
Figure 25: Solar Panel Covered with Dust.....	127
Figure 26: Benchmark Solar PV Plant Cost Breakdown according to CERC.....	136

Contents

FIGURES

Appendix A – Concentrated Solar Power

Figure 1: Average Daily Direct Normal Solar Irradiation for Selected Asian Countries (kWh/m ² /day)	153
Figure 2: Ideal Representation of a Concentrating Solar Power System.....	154
Figure 3: Solar Thermal Concentrator Types	155
Figure 4: Typical CSP Power Plant Schematic (Parabolic Trough with Storage)	155
Figure 5: Implementation of CSP Technologies.....	157
Figure 6: Generating Cost for Recently Completed and Under Construction CSP Projects.....	157
Figure 7: An Example of a Parabolic Trough Concentrator	160
Figure 8: An Example of a Parabolic Concentrator Solar Plant.....	161
Figure 9: Component Cost as a Percentage of Overall Plant Cost	163
Figure 10: Installed Cost of a Parabolic Trough Plant with Storage	164
Figure 11: Generating Cost of a Parabolic Trough Plant.....	165
Figure 12: An Example of Solar Power Tower Technology	167
Figure 13: An Example of a Parabolic Dish System	169
Figure 14: Implementation of Energy Storage in CSP Plants.....	171
Figure 15: ISCC Plant Schematic.....	175
Figure 16: Illustration of Typical CPV Concentrating Mechanism	177
Figure 17: Example of SolFocus CPV Installation.....	177
Figure 18: Kimberlina solar thermal energy plant, installed by AREVA Solar (USA).....	178

Contents

TABLES

Table 1: Characteristics of Various PV technology classes	28
Table 2: PV Module Standards	29
Table 3: Indicative List of Inverter-related Standards	38
Table 4: Inter-Annual Variation in Solar Resource From Analysis of NASA SSE	44
Table 5: Losses in a PV Power Plant	62
Table 6: Comparison of Module Technical Specifications at STC	69
Table 7: Inverter Selection Criteria	70
Table 8: Inverter Specification	73
Table 9: Definition of Ingress Protection (IP) Ratings	83
Table 10: Performance Optimisation Strategies	98
Table 11: Annotated Wiring Diagram Requirements	101
Table 12: Solar PV Project Interfaces	111
Table 13: Typical EPC Payment Schedule	114
Table 14: Warranty Types and Requirements	115
Table 15: Benchmark Costs	137

Appendix A – Concentrated Solar Power

Table 1: CSP Installed Capacity (MW)	156
Table 2: Comparison of Solar Thermal Concentrating Technologies	159
Table 3: Parabolic Trough Reference Plant Characteristic	164
Table 4: Condenser Cooling Options	174
Table 5: Water Requirements for Different CSP Plant Types	175
Table 6: Examples of ISCC Plants	176
Table 7: Load Matching Options	183

Appendix B – AC Benchmarks

Table 1: Cable Specification	186
Table 2: Switchgear Specification	186
Table 3: Transformer Specification	187

Appendix C – EPC Contract Model Heads of Terms

Table 1 – Milestone Payments and Transfer of Title	191
--	-----

List of abbreviations

°C	Degrees Centigrade	CPV	Concentrating Photovoltaic	HV	High Voltage	Tracking	
A	Amp	CSP	Concentrated Solar Power	IFC	International Finance Corporation	MTBF	Mean Times Between Failures
AC	Alternating Current	DC	Direct Current	IEC	International Electrotechnical Commission	NAPCC	National Action Plan for Climate Change
AOD	Aerosol Optical Depth	DIN	Deutsches Institut für Normung	IP	International Protection Rating or Internet Protocol	NREL	National Renewable Energy Laboratory
a-Si	Amorphous Silicon	DNI	Direct Normal Irradiation	IRR	Internal Rate of Return	NVVN	NTPC Vidhyut Vyapar Nigam (NVVN)
CB	Circuit Breaker	DSCR	Debt Service Coverage Ratio	ISC	Short-Circuit Current	O&M	Operations and Maintenance
CDM	Clean Development Mechanism	EIA	Environmental Impact Assessment	JNNSM	Jawaharlal Nehru National Solar Mission	PPA	Power Purchase Agreement
c-Si	Crystalline Silicon	EN	European Norm	kWh	Kilowatt Hour	PR	Performance Ratio
CCGT	Combined Cycle Gas Turbine	EPC	Engineer Procure Construct	LTV	Loan to Value	PV	Photovoltaic
CdTe	Cadmium Telluride	FiT	Feed-in Tariff	LV	Low Voltage	REC	Renewable Energy Certificate
CE	Conformité Européenne	GHI	Global Horizontal Irradiation	MET	Meteorological	RPO	Renewable Purchase Obligation
CER	Certified Emission Reduction	GSM	Global System for Mobile Communications	MNRE	Ministry of Renewable Energy	SCADA	Supervisory Control and Data Acquisition
CERC	Central Electricity Regulatory Commission			MPP	Maximum Power Point		
CIGS	Copper Indium (Gallium) Di-Selenide			MPPT	Maximum Power Point		

1. INTRODUCTION

The objective of this guidebook is to communicate how to successfully finance, develop, construct and operate a utility scale PV power plant.

Throughout the guide, a number of case studies have been included to illustrate specific aspects of the development and construction of solar PV projects in India. These case studies are based on a real solar PV project of 5 MWp capacity located in India. While the studies are based on this one specific project, many of the issues addressed are relevant to other locations and many of the challenges faced by this project will be common across solar power plant projects in India. This plant was the first of its kind on this scale in India and served as a demonstration plant. It is in this context that the case studies should be read.

The layout design recommendations assume the plant is located in the northern hemisphere, although the concepts may be extended to southern hemisphere locations.

Annex A gives an overview of CSP technology and highlights key differences between the PV and CSP project development processes. Other appendices provide technical benchmarks for AC equipment and heads of terms for EPC and O&M contracts. The guidebook may also be read in conjunction with the Indian market analysis report^[2].

[2] IFC Market Analysis on Solar Power Generation in India (SgurrEnergy Limited).

Case Studies

The case studies will highlight a wide range of issues and lessons learned from the development and construction of the 5 MW plant in Tamil Nadu, India. However, it should be noted that many of these issues (e.g. the losses to be applied in an energy yield prediction or the importance of a degree of adjustability in a supporting structure) come down to the same fundamental point: it is essential to get suitable expertise in the project team. This does not only apply to technical expertise but also to financial, legal and other relevant fields. It can also be achieved in a variety of ways: e.g. hiring staff, using consultants or partnering with other organisations.

Issues and lessons described in these case studies will inform the actions of other developers and help promote good practice in the industry to ensure that best practices can be followed to support project financing in this sector.

2. SOLAR PV TECHNOLOGY

This section of the guidebook discusses PV applications, module technologies, mounting systems, inverters, monitoring and forecasting techniques. It provides an overview of current commercially available technologies used in utility scale solar PV projects. The purpose is to provide a framework of understanding for developers and investors before they commit to a specific technology.

2.1 Applications of Solar PV

There are four primary applications for PV power systems:

- **Off-grid domestic** – Providing electricity to households and villages that are not connected to the utility electricity network (the “grid”).
- **Off-grid non-domestic** – Providing electricity for a wide range of applications such as telecommunication, water pumping and navigational aids.
- **Grid-connected distributed PV** – Providing electricity to a specific grid-connected customer.
- **Grid-connected centralised PV** – Providing centralised power generation for the supply of bulk power into the grid.

The focus of this guidebook is on grid-connected centralised PV power plants. However much of the guidebook is also relevant to other applications.

2.2 Overview of Ground Mounted PV Power Plant

Figure 1 gives an overview of a megawatt scale grid-connected solar PV power plant. The main components include:

- **Solar PV modules** – These convert solar radiation directly into electricity through the photovoltaic effect in a silent and clean process that requires no moving parts. The photovoltaic effect is a semiconductor effect whereby solar radiation falling

onto the semiconductor PV cells generates electron movement. The output from a solar PV cell is direct current (DC) electricity. A PV power plant contains many cells connected together in modules and many modules connected together in strings^[3] to produce the required DC power output.

- **Module mounting (or tracking) systems** – These allow PV modules to be securely attached to the ground at a fixed tilt angle, or on sun-tracking frames.
- **Inverters** – These are required to convert the DC electricity to alternating current (AC) for connection to the utility grid. Many modules in series strings and parallel strings are connected to the inverters.
- **Step-up transformers** – The output from the inverters generally requires a further step-up in voltage to reach the AC grid voltage level. The step-up transformer takes the output from the inverters to the required grid voltage (for example 25 kV, 33 kV, 38 kV, 110 kV depending on the grid connection point and requirements).
- **The grid connection interface** – This is where the electricity is exported into the grid network. The substation will also have the required grid interface switchgear such as circuit breakers and disconnects for protection and isolation of the PV power plant as well as generation and supply metering equipment. The substation and metering point are often external to the PV power plant boundary and are typically located on the network operator’s property^[4].

2.3 Solar PV Modules

This section describes commercially available technology options for solar PV modules, discusses module certification and module manufacturers, and elaborates on how solar PV module performance can degrade over time.

[3] Modules may be connected together in series to produce a string of modules. When connected in series the voltage increases. Strings of modules connected in parallel increase the current output.

[4] Responsibility for this is defined in the grid connection contract. Normally, it is the grid operator’s onus to maintain the equipment in the grid operator’s boundary—and there will be a cost to be paid by the PV plant owner.

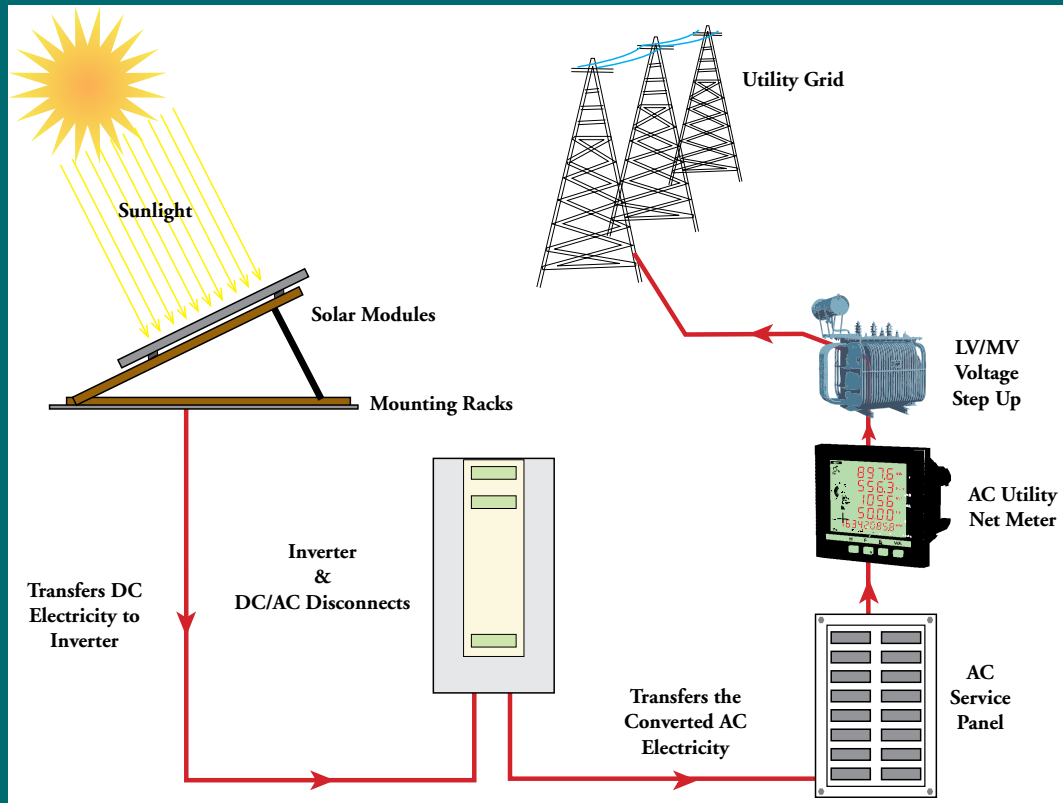

Figure 1: Overview of Solar PV Power Plant

2.3.1 Background on PV Materials

The unusual electrical properties required for PV cells limit the raw materials from which they may be manufactured. Silicon is the most common material while cells using cadmium telluride and copper indium (gallium) di-selenide are also available. Each material has unique characteristics that impact the cell performance, manufacturing method and cost.

PV cells may be based on either silicon wafers (manufactured by cutting wafers from a solid ingot block of silicon) or “thin film” technologies (in which a thin layer of a semiconductor material is deposited on low-cost substrates).

PV cells can further be characterised according to the long range structure of the semiconductor material, “mono-crystalline”, “multi-crystalline” (also known as “poly-crystalline”) or less ordered “amorphous” material.

Figure 2(a) summarises the technology classes:

- **Crystalline Silicon (c-Si)** – Modules are made from cells of either mono-crystalline or multi-crystalline silicon. Mono-crystalline silicon cells are generally the most efficient, but are also more costly than multi-crystalline.
- **Thin Film** – Modules are made with a thin film deposition of a semiconductor onto a substrate. This class includes semiconductors made from:
 - Amorphous silicon (a-Si).
 - Cadmium telluride (CdTe).
 - Copper indium selenide (CIS).
 - Copper indium (gallium) di-selenide (CIGS).

As of January 2010, approximately 78% of the global installed capacity of solar PV power plants use wafer-based crystalline silicon modules. Amorphous silicon and cadmium telluride thin film modules make up the remaining 22%.

2.3.3 Thin Film PV Modules

Crystalline wafers provide high efficiency solar cells but are relatively costly to manufacture. In comparison, thin film cells are typically cheaper due to both the materials used and the simpler manufacturing process. However, thin film cells are less efficient.

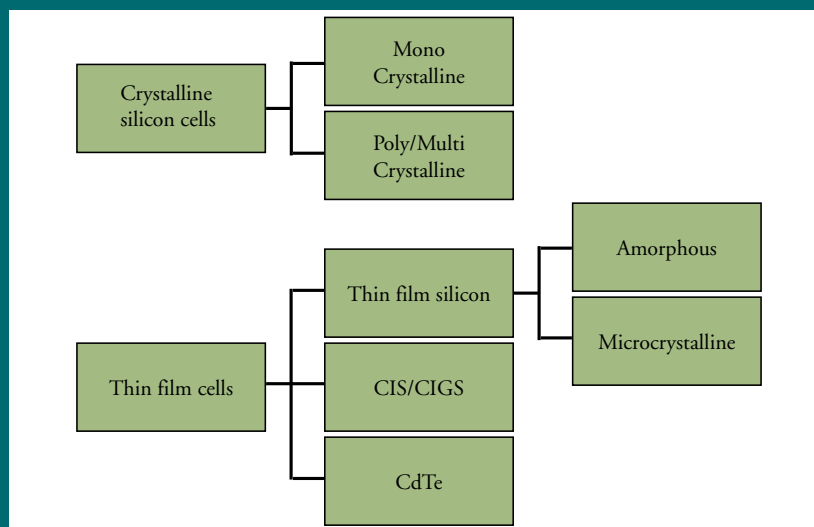

Figure 2(a): PV Technology Classes

2.3.2 Crystalline Silicon PV Modules

Crystalline silicon modules consist of PV cells (typically between 12.5 square cm and 20 square cm) connected together and encapsulated between a transparent front (usually glass), and a backing material (usually plastic or glass).

Mono-crystalline wafers are sliced from a large single crystal ingot in a relatively expensive process.

Cheaper, multi-crystalline wafers may be made by a variety of techniques. One of the technologies involves the carefully controlled casting of molten poly-silicon, which is then sliced into wafers. These can be much larger than mono-crystalline wafers. Multi-crystalline cells produced in this way are currently cheaper but the end product is generally not as efficient as mono-crystalline technology.

The most well-developed thin film technology uses silicon in its less ordered, non-crystalline (amorphous) form. Other technologies use cadmium telluride and copper indium (gallium) di-selenide with active layers less than a few microns thick. In general, thin film technologies have a less established track record than many crystalline technologies. The main characteristics of thin film technologies are described in the following sections.

2.3.3.1 Amorphous Silicon

In amorphous silicon technologies, the long range order of crystalline silicon is not present and the atoms form a continuous random network. Since amorphous silicon absorbs light more effectively than crystalline silicon, the cells can be much thinner.

Amorphous silicon (a-Si) can be deposited on a wide range of both rigid and flexible low cost substrates. The low cost of a-Si makes it suitable for many applications where low cost is more important than high efficiency.

2.3.3.2 Cadmium Telluride

Cadmium telluride (CdTe) is a compound of cadmium and tellurium. The cell consists of a semiconductor film stack deposited on transparent conducting oxide-coated glass. A continuous manufacturing process using large area substrates can be used. Modules based on CdTe produce a high energy output across a wide range of climatic conditions with good low light response and temperature response coefficients.

2.3.3.3 Copper Indium (Gallium) Di-Selenide (CIGS/CIS)

CIGS is a semiconductor consisting of a compound of copper, indium, gallium and selenium.

CIGS absorbs light more efficiently than crystalline silicon, but modules based on this semiconductor require somewhat thicker films than a-Si PV modules. Indium is a relatively expensive semiconductor material, but the quantities required are extremely small compared to wafer based technologies.

Commercial production of CIGS modules is in the early stages of development. However, it has the potential to offer the highest conversion efficiency of all the thin film PV module technologies.

2.3.4 Module Degradation

The performance of a PV module will decrease over time. The degradation rate is typically higher in the first year upon initial exposure to light and then stabilises.

Factors affecting the degree of degradation include the quality of materials used in manufacture, the manufacturing

process, the quality of assembly and packaging of the cells into the module, as well as maintenance levels employed at the site. Regular maintenance and cleaning regimes may reduce degradation rates but the main impact is specific to the characteristics of the module being used. It is, therefore, important that reputable module manufacturers are chosen and power warranties are carefully reviewed.

The extent and nature of degradation varies among module technologies. For crystalline modules, the cells may suffer from irreversible light-induced degradation. This can be caused by the presence of boron, oxygen or other chemicals left behind by the screen printing or etching process of cell production. The initial degradation occurs due to defects that are activated on initial exposure to light.

Amorphous silicon cells degrade through a process called the Staebler-Wronski Effect^[5]. This degradation can cause reductions of 10-30% in the power output of the module in the first six months of exposure to light. Thereafter, the degradation stabilises and continues at a much slower rate.

Amorphous silicon modules are generally marketed at their stabilised performance levels. Interestingly, degradation in amorphous silicon modules is partially reversible with temperature. In other words, the performance of the modules may tend to recover during the summer months, and drop again in the colder winter months.

Additional degradation for both amorphous and crystalline technologies occurs at the module level and may be caused by:

- Effect of the environment on the surface of the module (for example pollution).
- Discolouration or haze of the encapsulant or glass.
- Lamination defects.

[5] An effect in which the electronic properties of the semiconductor material degrade with light exposure.

Table 1: Characteristics of various PV technologies^[7]

Technology	Crystalline Silicon	Amorphous Silicon	Cadmium Telluride	Copper Indium Gallium Di-Selenide
Abbreviation	c-Si	a-Si	CdTe	CIGS or CIS
Cost (\$/W _p , 2009)	3.1-3.6	2.5-2.8	2.1-2.8	2.7-2.9
Percentage of Global installed capacity ^[8]	78%	22%		
Thickness of cell	Thick layers (200-300μm)	Thin layers (<1μm)	Thin layers (<1μm)	Thin layers (<1μm)
Current commercial efficiency	12-19%	5-7%	8-11%	8-11%
Temperature coefficient for power ^[9] (Typical)	-0.50%/°C	-0.21%/°C	-0.25%/°C	-0.36%/°C

- Mechanical stress and humidity on the contacts.
- Cell contact breakdown.
- Wiring degradation.

PV modules may have a long term power output degradation rate of between 0.3% and 1% per annum. For crystalline modules, a generic degradation rate of 0.5% per annum is often considered applicable (if no specific testing has been conducted on the modules being used^[6]). Banks often assume a flat rate of degradation rate of 0.5% per annum.

In general, good quality PV modules may be expected to have a useful life of 25-30 years. The possibility of increased rates of degradation becomes higher thereafter.

2.3.5 Module Cost and Efficiency

Table 1 shows the cost and commercial efficiency of some PV technology categories. As may be expected, while higher

efficiency technologies are more costly to manufacture, less efficient modules require a larger area to produce the same nominal power. As a result, the cost advantages gained at the module level may get offset by the cost incurred in providing additionally required power system infrastructure (cables and mounting frames) for a larger module area. So using the lowest cost module does not necessarily lead to the lowest cost per W_p for the complete plant. The relationship between plant area and module efficiency is discussed in Section 5.2.2.

At the time of writing, crystalline silicon technology comprises almost 80% of global installed solar capacity and is likely to remain dominant in the short term. But the presence of thin film technologies is growing. As of 2010, Cadmium Telluride accounted for the large majority of installed thin film capacity but CIGS is thought to have promising cost reduction potential

2.3.6 Certification

The International Electrotechnical Commission (IEC) issues internationally accepted standards for PV modules. PV modules will typically be tested for durability and reliability

[6] US Department of Energy, National Renewable Energy Laboratory.
 [7] ASIF: Informe Annual 2009. Maximum efficiency values taken from "Best Production-Line PV Module Efficiency Values From Manufacturers' Websites" compiled by Bolko von Roedern, NREL 9-2009
 [8] "Global Market Outlook for Photovoltaics until 2014" www.epia.org (Concentrating PV and other minor technologies not shown).
 [9] The temperature coefficient for power describes the dependence on power output with increasing temperature. Module power generally decreases as the module temperature increases.

according to these standards. Standards IEC 61215 (for crystalline silicon modules) and IEC 61646 (for thin film modules) include tests for thermal cycling, humidity and freezing, mechanical stress and twist, hail resistance and performance under some fixed test conditions, including standard testing conditions (STC)^[10].

Table 2 summarises major PV quality standards. These are an accepted quality mark and indicate that the modules can safely withstand extended use. However, they say very little about the performance of the module under field conditions of varying irradiance and temperature experienced at a specific site location.

Table 2: PV Module Standards

Test	Description	Comment
IEC 61215	Crystalline silicon terrestrial photovoltaic (PV) modules – Design qualification and type approval.	The standard certification uses a 2,400 Pa pressure. Modules in heavy snow locations may be tested under more stringent 5,400 Pa conditions.
IEC 61646	Thin-film terrestrial photovoltaic (PV) modules – Design qualification and type approval.	Very similar to the IEC 61215 certification, but an additional test specifically considers the additional degradation of thin film modules.
EN/IEC 61730	PV module safety qualification.	Part 2 of the certification defines three different Application Classes: <ol style="list-style-type: none"> 1). Safety Class 0 – Restricted access applications. 2). Safety Class II – General applications. 3). Safety Class III – Low voltage applications.
IEC 60364-4-41	Protection against electric shock.	Module safety assessed based on: <ol style="list-style-type: none"> 1). Durability. 2). High dielectric strength. 3). Mechanical stability. 4). Insulation thickness and distances.
IEC 61701	Resistance to salt mist and corrosion	Required for modules being installed near the coast or for maritime applications.
Conformité Européenne (EC)	The certified product conforms to the EU health, safety and environmental requirements.	Mandatory in the European Economic Area.
UL 1703	Comply with the National Electric Code (NEC), OSHA and the National Fire Prevention Association. The modules perform to at least 90% of the manufacturer's nominal power.	Underwriters Laboratories Inc. (UL) is an independent U.S. based product safety testing certification company which is a Nationally Recognised Testing Laboratory (NRTL). Certification by a NRTL is mandatory in the U.S.

[10] STC, Standard Test Conditions are defined as an irradiance of 1000W/m² at a spectral density of AM 1.5 (ASTM E892) and cell temperature of 25°C.

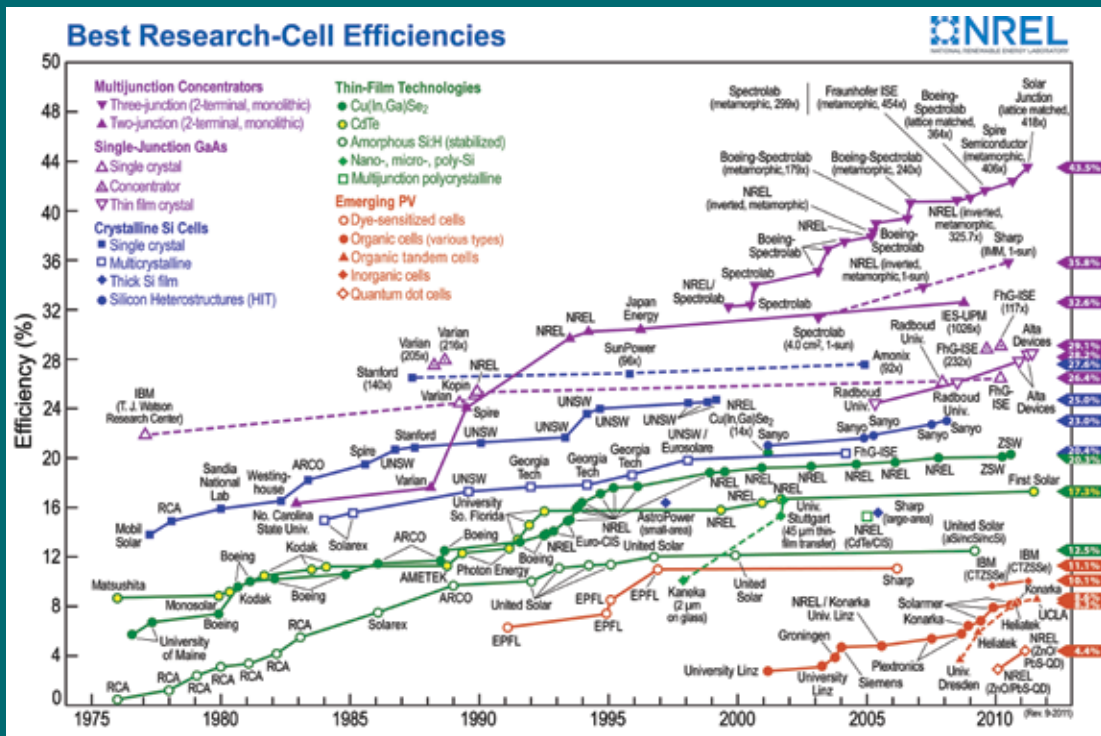

Figure 2(b): Development of Research Cell Efficiencies^[12]

This diagram was created by the National Renewable Energy Laboratory for the Department of Energy

There are efforts to create a new standard, IEC 61853, which will test the performance and energy rating of modules under a variety of irradiance and temperature conditions. This standard should facilitate comparison and selection of modules, based on performance.

2.3.7 Module Manufacturers

Manufacturers of PV modules are based predominantly in Europe, China and North America^[11]. A 2009 survey by Photon International (2-2009) indicated that there were over 220 suppliers of PV modules and over 2,700 products. When assessing the quality of a module for any specific project, it is important to assess its specifications, certifications, track record, and the track record of the manufacturer.

There are currently a few large module manufacturers dominating the market. Financial institutions often keep lists of module manufacturers they consider bankable. However, these lists can quickly become dated as manufacturers introduce new products and quality procedures. Often, the larger manufacturers (such as Suntech, Sunpower or First Solar) are considered bankable, but there is no definitive and accepted list.

2.3.8 Module Technology Developments

Solar PV module technology is developing rapidly. While a wide variety of different technical approaches are being explored, the effects of these approaches are focused on either improving module efficiency or reducing manufacturing costs.

Incremental improvements are being made to conventional c-Si cells. One of these improvements is the embedding of the front contacts in laser-cut microscopic grooves in order to

[11] There are several module manufacturers in India but the current installed production capacity is still under 1000 MWp per annum. India exports a major portion of the production. The dominant technology is crystalline silicon with amorphous silicon gaining ground.

[12] Image courtesy from United States National Renewable Energy Laboratory www.nrel.com, it can be accessed April 2011.

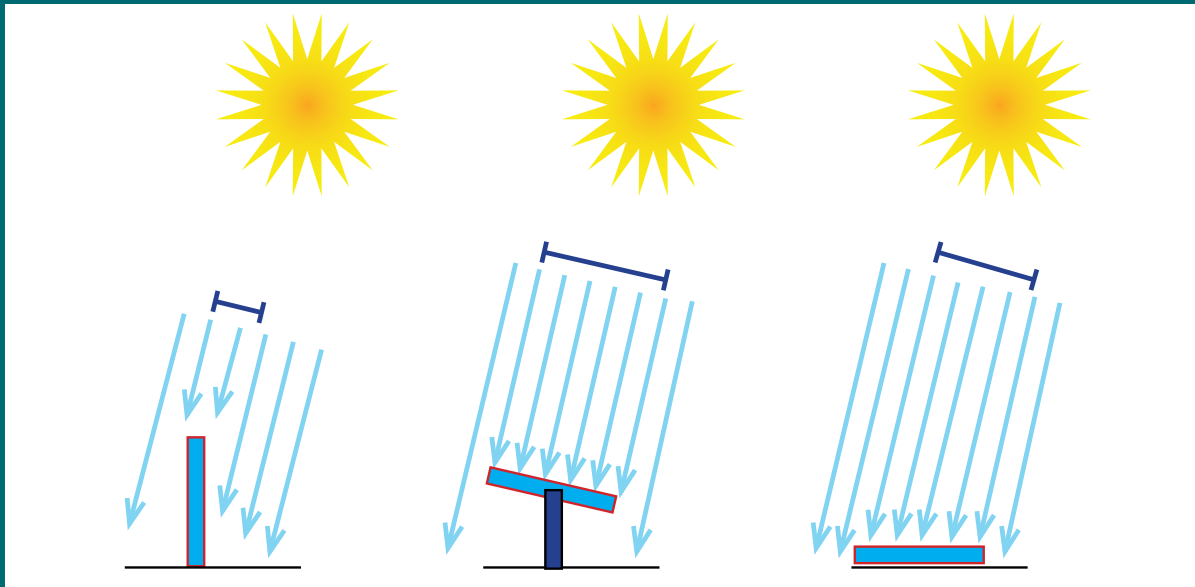

Figure 3: Effect of Tilt on Solar Energy Capture

reduce the surface area of the contacts and so increase the area of the cell that is exposed to solar radiation. Similarly, another approach involves running the front contacts along the back of the cell and then directly through the cell to the front surface at certain points.

Different types of solar cell inherently perform better at different parts of the solar spectrum. As such, one area of interest is the stacking of cells of different types. If the right combination of solar cells is stacked (and the modules are sufficiently transparent) then a stacked or “multi-junction” cell can be produced which performs better across a wider range of the solar spectrum. This approach is taken to the extreme in III-V cells (named after the respective groups of elements in the Periodic Table) in which the optimum materials are used for each part of the solar spectrum. III-V cells are very expensive but have achieved efficiencies in excess of 40%. Less expensive approaches based on the same basic concept include hybrid cells (consisting of stacked c-Si and thin film cells) and multi-junction a-Si cells.

Other emerging technologies which are not yet market ready but could be of commercial interest in future include spherical cells, sliver cells and dye sensitised or organic cells.

Figure 2(b) illustrates the development of the efficiencies of research cells from 1975 to the present day. It should be noted that commercially available cells lag significantly behind research cells in terms of efficiency.

2.4 Mounting and Tracking Systems

PV modules must be mounted on a structure, to keep them oriented in the correct direction and to provide them with structural support and protection. Mounting structures may be fixed or tracking.

2.4.1 Fixed Mounting Systems

Fixed mounting systems keep the rows of modules at a fixed tilt angle^[13] while facing a fixed angle of orientation^[14]. Figure 3 illustrates why the tilt angle is important for maximising the energy incident on the collector plane.

[13] The tilt angle or “inclination angle” is the angle of the PV modules from the horizontal plane.

[14] The orientation angle or “azimuth” is the angle of the PV modules relative to south. East is -90° south is 0° and west is 90°.

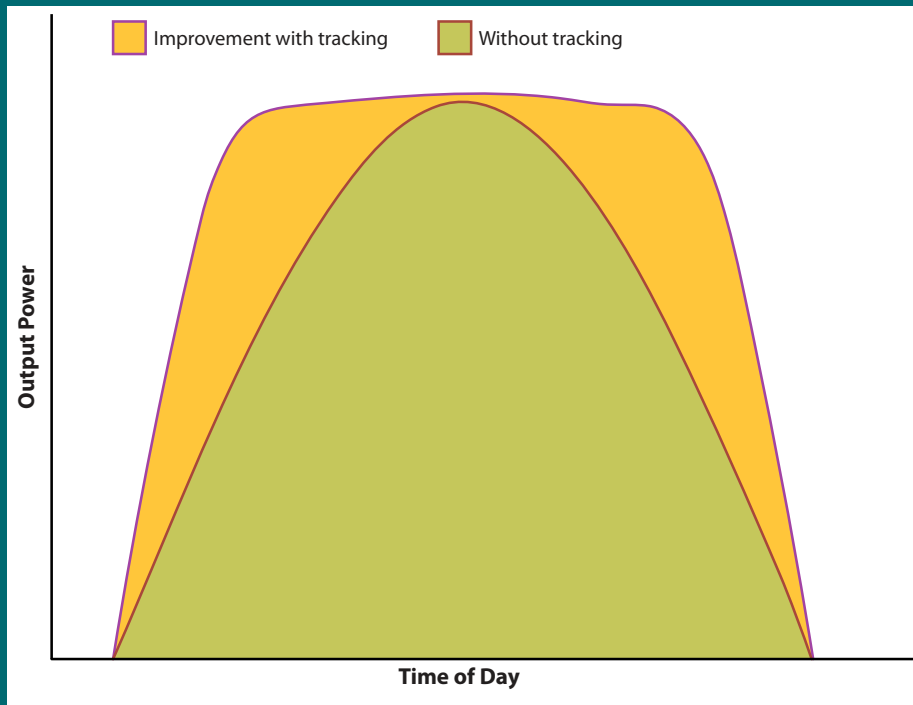

Figure 4: Benefit of Dual Axis Tracking System

2.4.2 Tracking Systems

The tilt angle and orientation is generally optimised for each PV power plant according to location. This helps to maximise the total annual incident irradiation^[15] and total annual energy yield. For Indian sites, the optimum tilt angle is generally between 10° and 35°, facing true south. There are several off-the-shelf software packages that may be used to optimise the tilt angle and orientation according to specifics of the site location and solar resource.

Fixed tilt mounting systems are simpler, cheaper and have lower maintenance requirements than tracking systems. They are the preferred option for countries with a nascent solar market and limited indigenous manufacturing of tracking technology.

In locations with a high proportion of direct irradiation including some regions of India, single or dual-axis tracking systems can be used to increase the average total annual irradiation. Tracking systems follow the sun as it moves across the sky. They are generally the only moving parts employed in a PV power plant.

Single-axis trackers alter either the orientation or tilt angle only, while dual-axis tracking systems alter both orientation and tilt angle. Dual-axis tracking systems are able to track the sun more precisely than single-axis systems.

Depending on the site and precise characteristics of the solar irradiation, trackers may increase the annual energy yield by up to 27% for single-axis and 37% for dual-axis trackers. Tracking also produces a smoother power output plateau as shown in Figure 4. This helps meet peak demand in afternoons, which is common in hot climates due to the use of air conditioning units.

[15] Irradiation is the solar energy received on a unit area of surface. It is defined more fully in section 3.1.



Figure 5: An Example of a Tracking PV Plant

Almost all tracking system plants use crystalline silicon modules. This is because their higher efficiency reduces additional capital and operating costs required for the tracking system (per kWp installed). However, relatively inexpensive single-axis tracking systems have recently been used with some thin film modules.

There are many manufacturers and products of solar PV tracking systems. A 2009 survey of manufacturers by Photon International magazine (11-2009) listed 170 different devices with a wide range of tracking capabilities. Most fall into one of six basic design classes (classic dual-axis, dual-axis mounted on a frame, dual-axis on a rotating assembly, single-axis tracking on a tilted axis, tracking on a horizontal axis and single-axis tracking on a vertical axis). In general, the simpler the construction, the lower the extra yield compared to a fixed system, and the lower the maintenance requirement.

An example of a tracking PV plant is shown in Figure 5. Aspects to take into account when considering the use of tracking systems include:

Financial:

- Additional capital costs for the procurement and installation of the tracking systems (typically \$140-700/kWp).
- Additional land area required to avoid shading compared to a free field fixed tilt system of the same nominal capacity.
- Large tracking systems may require cranes to install, increasing the installation cost.
- There is a higher maintenance cost for tracking systems due to the moving parts and actuation systems. Typical additional maintenance costs range from \$2.8-21/kWp per annum.

Operational:

- Tracking angles: all trackers have angular limits that vary among products. Depending on the angular limits, performance may be reduced.
- High wind capability and storm mode: dual-axis tracking systems especially need to go into a storm mode when the wind speed is over 16-20 m/s. This could reduce the energy yield and revenues at high wind speed sites.
- Direct/diffuse irradiation ratio: tracking systems will give greater benefits in locations that have a higher direct irradiation component. This is discussed further in Section 3.

2.4.3 Certification

Support structures should adhere to country specific standards and regulations, and manufacturers should conform to ISO 9001:2000. This specifies requirements for a quality management system where an organisation needs to:

- Demonstrate its ability to consistently provide products that meet customer and applicable regulatory requirements.
- Aim to enhance customer satisfaction through the effective application of the system. These include processes for continual improvement as well as the assurance of conformity to customer and applicable regulatory requirements.

2.5 Inverters

Inverters are solid state electronic devices. They convert DC electricity generated by the PV modules into AC electricity, ideally conforming to the local grid requirements. Inverters can also perform a variety of functions to maximise the output of the plant. These range from optimising the voltage across the strings and monitoring string performance to logging data, and providing protection and isolation in case of irregularities in the grid or with the PV modules.

2.5.1 Inverter Connection Concepts

There are two broad classes of inverters: central inverters and string inverters. The central inverter configuration shown in Figure 6 remains the first choice for many medium and large scale solar PV plants. A large number of modules are connected in series to form a high voltage string. Strings are then connected in parallel to the inverter.

Central inverters offer high reliability and simplicity of installation. However, they have disadvantages: increased mismatch losses^[16] and absence of maximum power point tracking^[17] (MPPT) for each string. This may cause problems for arrays that have multiple tilt and orientation angles, suffer from shading, or use different module types.

Central inverters are usually three-phase and can include grid frequency transformers. These transformers increase the weight and volume of the inverters although they provide galvanic isolation from the grid. In other words, there is no electrical connection between the input and output voltages—a condition that is sometimes required by national electrical safety regulations.

Central inverters are sometimes used in a “master slave” configuration. This means that some inverters shut down when the irradiance is low, allowing the other inverters to run more closely to optimal loading. When the irradiance is high, the load is shared by all inverters. In effect, only the required number of inverters is in operation at any one time. As the operating time is distributed uniformly among the inverters, design life can be extended.

[16] Mismatch refers to losses due to PV modules with varying current/voltage profiles being used in the same array.

[17] Maximum Power Point Tracking is the capability of the inverter to adjust its impedance so that the string is at an operating voltage that maximises the power output.

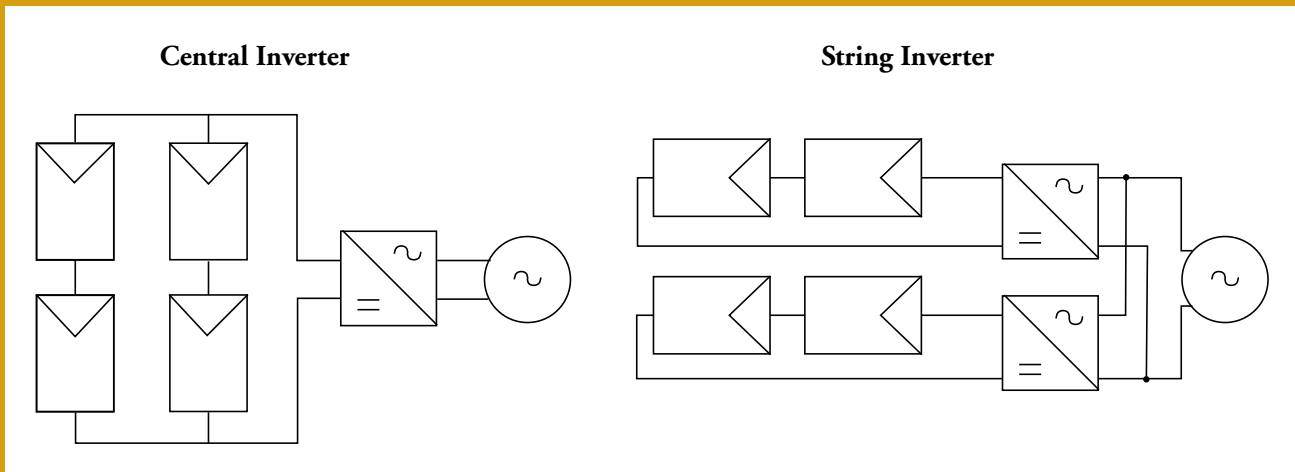

Figure 6: PV System Configurations

In contrast, the string inverter concept uses multiple inverters for multiple strings of modules. String inverters are increasingly being used as they can cover a very wide power range and can be manufactured more cheaply in a production line than central inverters. Additionally, they provide MPPT on a string level with all strings being independent of each other. This is useful in cases where modules cannot be installed with the same orientation, where modules of different specifications are being used, or when there are shading issues.

String inverters, which are usually in single phase, also have other advantages. For one, they can be serviced and replaced by non-specialist personnel. For another, it is practical to keep spare string inverters on site. This makes it easy to handle unforeseen circumstances, as in the case of an inverter failure. In comparison, the failure of a large central inverter—with a long lead time for repair—can lead to significant yield loss before it can be replaced.

Inverters may be transformerless or include a transformer to step up the voltage. Transformerless inverters generally have a higher efficiency, as they do not include transformer losses.

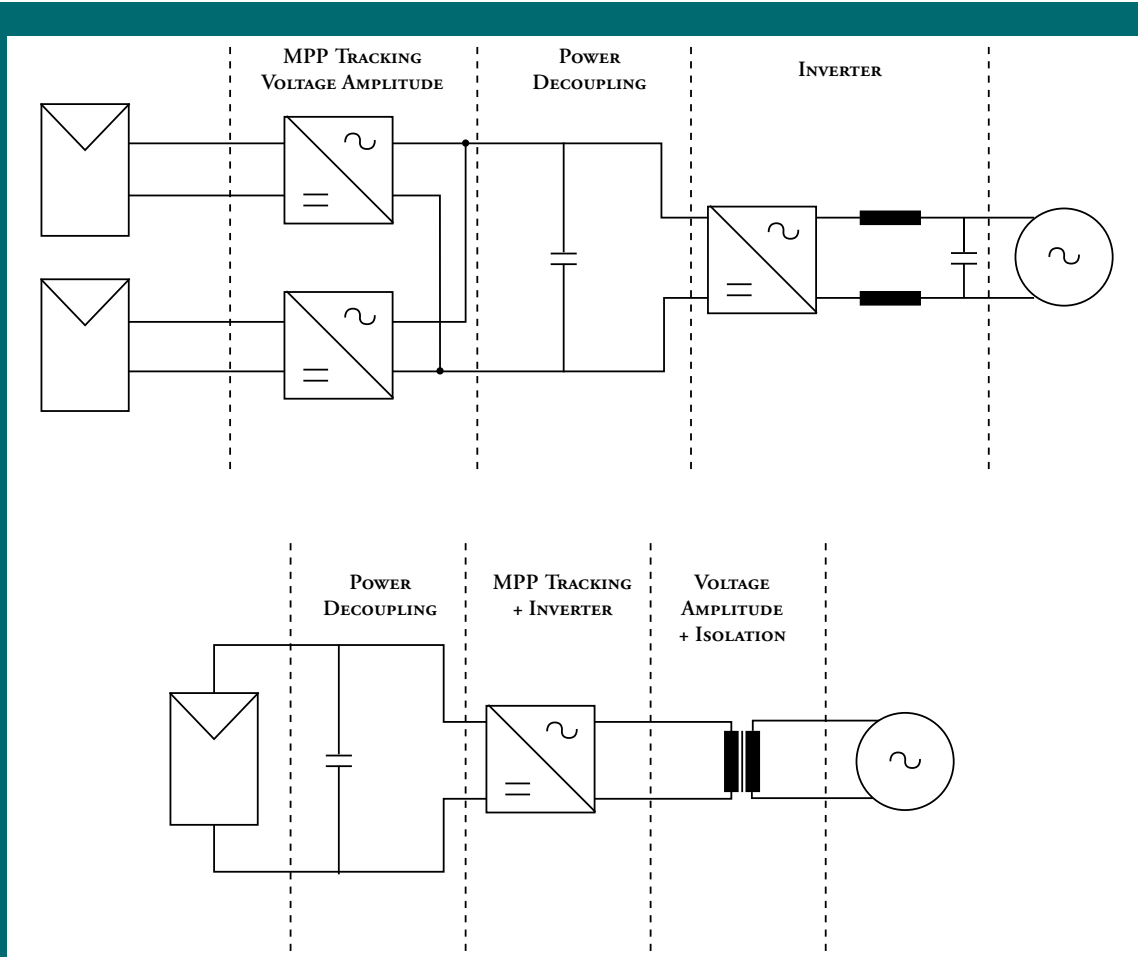

Figure 7: Transformer and Transformerless Inverter Schematic

In the case of transformerless string inverters (see Figure 7), the PV generator voltage must either be significantly higher than the voltage on the AC side, or DC-DC step-up converters must be used. The absence of a transformer leads to higher efficiency, reduced weight, reduced size (50-75% lighter than transformer-based models^[18]) and lower cost due to the smaller number of components. On the downside, additional protective equipment must be used, such as DC sensitive earth-leakage circuit breakers (CB), and live parts must be protected. IEC Protection Class II^[19] must be implemented

across the installation. Transformerless inverters also cause increased electromagnetic interference (EMI).

Inverters with transformers provide galvanic isolation. Central inverters are generally equipped with transformers. Safe voltages (<120 V) on the DC side are possible with this design. The presence of a transformer also leads to a reduction of leakage currents, which in turn reduces EMI. But this design has its disadvantages in the form of losses (load and no-load^[20]), and increased weight and size of the inverter.

[18] A Review of PV Inverter Technology Cost and Performance Projections, NREL Standards, Jan 2006.

[19] IEC Protection Class II refers to a device that is double insulated and therefore does not require earthing.

[20] The load-dependent copper losses associated with the transformer coils are called load losses. The load-independent iron losses produced by the transformer core magnetising current are called no-load losses.

2.5.2 Power Quality/Grid Code Compliance

Power quality and grid code requirements are country-dependent. It is not possible to provide universally applicable guidelines. The national regulations and standards should be consulted when selecting an inverter and designing a solar PV power plant.

In general, one of the quantities used to describe the quality of a grid-connected inverter is total harmonic distortion (THD). It is a measure of the harmonic content of the inverter output and must be limited in most grid codes. For high quality devices, THD is normally less than 5%^[21].

2.5.3 Efficiency

A number of different measures of efficiency have been defined for inverters. These describe and quantify the efficiency of different aspects of an inverter's operation. The search for an objective way of quantifying inverter performance is still ongoing. New ways of measuring efficiency are frequently suggested in industry literature. The most commonly used methods are discussed below.

The conversion efficiency is a measure of the losses experienced during the conversion from DC to AC. These losses are due to multiple factors: the presence of a transformer and the associated magnetic and copper

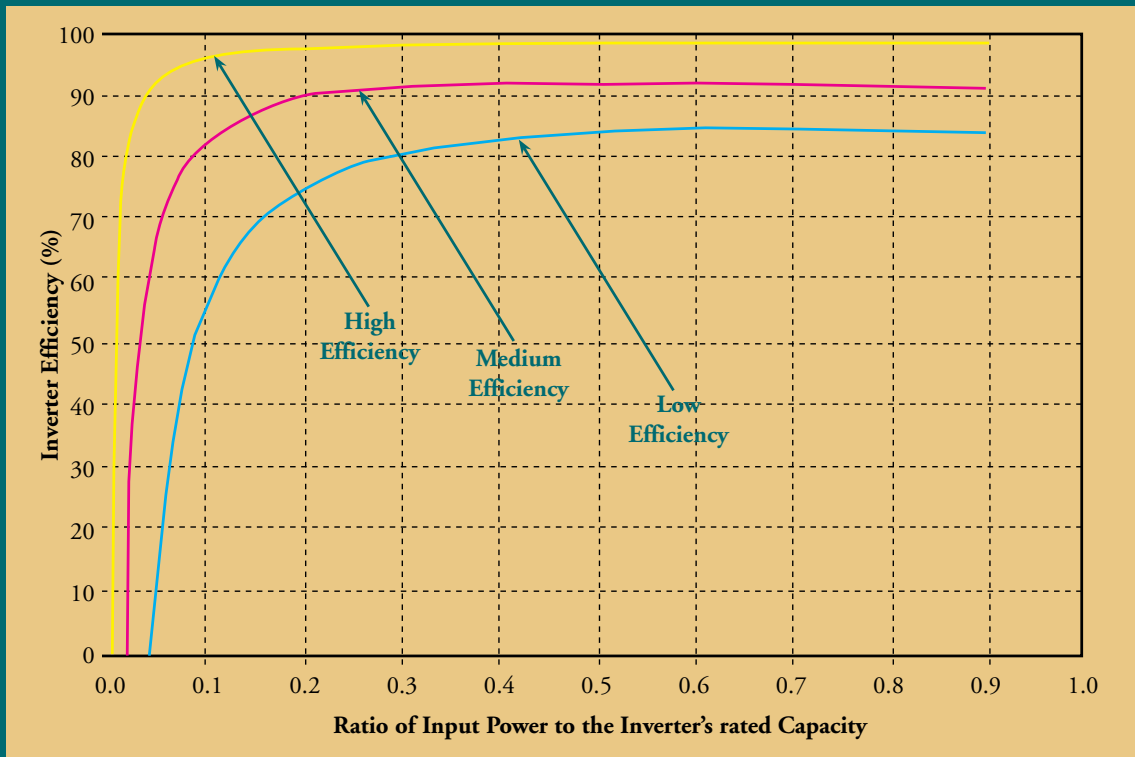

Figure 8: Efficiency Curves of Low, Medium and High Efficiency Inverters as Functions of the Input Power to Inverter Rated Capacity Ratios^[22]

[21] Handbook of Photovoltaic Science and Engineering (Wiley, 2003)

[22] Jayanta Deb Mondol, Yigzaw G. Yohanis, Brian Norton. Optimal sizing of array and inverter for grid-connected photovoltaic systems, 2006.

losses, inverter self-consumption, and losses in the power electronics. Conversion efficiency is defined as the ratio of the fundamental component of the AC power output from the inverter, divided by the DC power input:

$$n_{Con} = \frac{P_{AC}}{P_{DC}} = \frac{\text{(Fundamental component of AC power output)}}{\text{(DC power input)}}$$

The conversion efficiency is not constant, but depends on the DC power input, the operating voltage, and the weather conditions including ambient temperature and irradiance. The variance in irradiance during a day causes fluctuations in the power output and maximum power point (MPP) of a PV array. As a result, the inverter is continuously subjected to different loads, leading to varying efficiency. The voltage at which inverters reach their maximum efficiency is an important design variable, as it allows system planners to optimise system wiring.

Due to the dynamic nature of inverter efficiency, it is better depicted through diagrams than by uniform numeric values. An example depicting the dependency of the inverter efficiency on the inverter load is given in Figure 8.

The European Efficiency is an accepted method of measuring inverter efficiency. It is a calculated efficiency averaged over a power distribution corresponding to operating climatic conditions of a central European location. As a useful means of comparing inverter efficiencies^[23], the efficiency standard also attempts to capture the fact that in central Europe most energy is generated near the middle of a PV module's power range.

Another method of comparing efficiencies is using the Californian Efficiency. While the standard is based on the same reasoning as the European efficiency, it is calibrated for locations with higher average irradiance.

[23] If $h_{50\%}$ denotes the efficiency at a load equal to 50% of the nominal power, the European Efficiency is defined as:

$$n_{Euro} = 0.03 \times n_{5\%} + 0.06 \times n_{10\%} + 0.13 \times n_{20\%} + 0.1 \times n_{30\%} + 0.48 \times n_{50\%} + 0.2$$

Table 3: Indicative list of inverter-related standards

EN 61000-6-1: 2007	Electromagnetic compatibility (EMC). Generic standards. Immunity for residential, commercial and light-industrial environments.
EN 61000-6-2: 2005	Electromagnetic compatibility (EMC). Generic standards. Immunity for industrial environments.
EN 61000-6-3: 2007	Electromagnetic compatibility (EMC). Generic standards. Emission standard for residential, commercial and light-industrial environments.
EN 61000-6-4: 2007	Electromagnetic compatibility (EMC). Generic standards. Emission standard for industrial environments.
EN 55022: 2006	Information technology equipment. Radio disturbance characteristics. Limits and methods of measurement.
EN 50178: 1997	Electronic equipment for use in power installations.
IEC 61683: 1999	Photovoltaic systems – Power conditioners – Procedure for measuring efficiency.

Inverters can have a typical European Efficiency of 95% and peak efficiencies of up to 98%. Most inverters employ MPPT algorithms to adjust the load impedance and maximise the power from the PV array. The highest efficiencies are reached by transformerless inverters.

Inverter manufacturers should measure the efficiency of their products, according to the IEC 61683 standard, to ensure that the results are accurate and compliant.

2.5.4 Certification

In order to ensure a high level of quality and performance, and to minimise risk, inverters must be compliant with a number of standards. The requirements, in terms of compliance with standards, depend on the location of the project and the type of inverter.

Important standards bodies for inverters are DIN VDE, IEC and EN. Inverters must be CE compliant in order to be installed in Europe. Table 3 is a non-exhaustive list of standards to which inverters should conform according to European practice.

2.5.5 Inverter Manufacturers

The inverter market is dominated by SMA Solar Technology AG, which has a higher market share than the combined share of the next four largest vendors (Kaco, Fronius, Power-One and Siemens) (as illustrated in Figure 9). Other inverter manufacturers hold the remaining 18% share of the global market^[24].

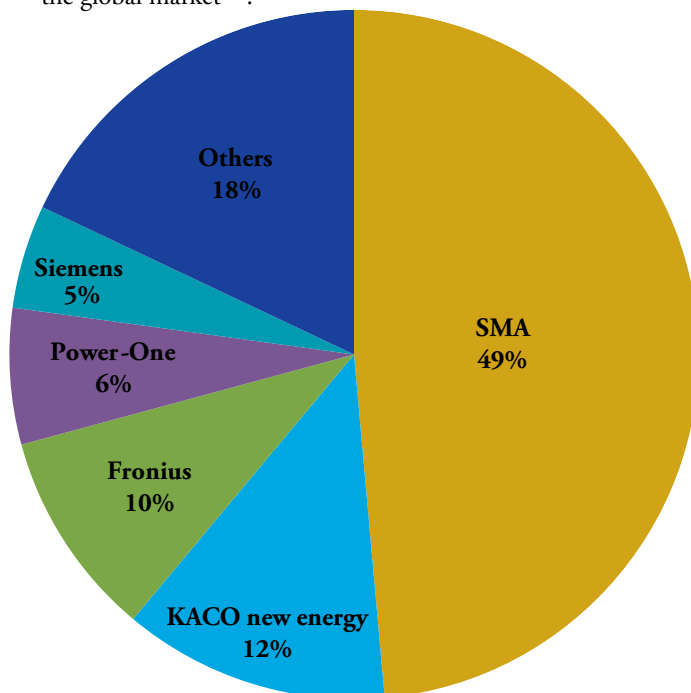

Figure 9: Inverter Manufacturer Market Share 2009^[24]

The latest global market survey for inverters conducted by Photon International magazine (04-2010) lists 1,068 inverter types, 532 of which are rated at 10 kW or less. Over a quarter of the inverter types belong to the 10 to 100 kW range.

Over the past year, a number of major industry players have started to enter the inverter market. These include GE, ABB, and Schneider Electric (through the acquisition of Xantrex). In 2010, the growth in the solar PV market and delays in production (due to scarcity of key electronic components) led to a global shortage of inverters.

2.6 Quantifying Plant Performance

The performance of a PV power plant is expected to fall during its lifetime, especially in the second and third decade of its life as modules continue to degrade and plant components age. In addition to the quality of the initial installation, a high degree of responsibility for the performance of a PV plant lies with the O&M contractor. This section discusses how the operational performance of a PV plant may be quantified.

2.6.1 Performance Ratio

The quality of a PV power plant may be described by its Performance Ratio (PR). The PR, usually expressed as a percentage, can be used to compare PV systems independent of size and solar resource. The PR may be expressed as:

$$PR = \frac{(AC \text{ Yield } (kWh))}{(Installed \text{ Capacity } (kWp) \times \text{Plane of Array Irradiation } (kWh/m^2)) \times 100\%}$$

By normalising with respect to irradiation, the PR quantifies the overall effect of losses on the rated output and allows a comparison between PV systems at different locations. A plant with a high PR is more efficient at converting solar

[24] Sun & Wind Energy February 2010

irradiation into useful energy. The PR of a plant may be predicted using simulations, or alternatively may be calculated for an operational plant by measuring irradiation, ambient temperature, wind velocity, module temperature, voltage and current over a given time period.

As PV plant losses vary according to environmental conditions through the year, the PR also varies. For example, the more significant negative temperature coefficient of power for crystalline modules may lead to increased losses at high ambient temperatures. A PR varying from approximately 77% in summer to 82% in winter (with an annual average PR of 80%) would not be unusual for a well-designed solar PV power plant that is not operating in high ambient temperature conditions.

Some plants using amorphous silicon modules show the opposite effect: in summer months, the PR increases, dropping again in the colder winter months. This is due to the fact that Staebler-Wronski degradation is partially reversible at high temperatures. It is common to observe seasonal oscillations in the PR of amorphous silicon plants due to this thermal annealing process.

Averaged across the year, a PR in the upper seventies or lower eighties is typical for a well-designed plant. This may be expected to reduce as the plant ages, dependent on the module degradation rates.

2.6.2 Capacity Factor

The capacity factor of a PV power plant (usually expressed as a percentage) is the ratio of the actual output over a period of one year and its output if it had operated at nominal power the entire year, as described by the formula:

$$CF = \frac{\text{Energy generated per annum (kWh)}}{(8760 \text{ (hours / annum)} \times \text{Installed Capacity (kWp)})}$$

The capacity factor of a fixed tilt PV plant in southern Spain will typically be in the region of 16%. This means that a 5 MWp plant will generate the equivalent energy of a continuously operating 0.8 MW plant. Plants in India operating within a reliable grid network are expected to have a similar capacity factor.

2.6.3 Specific Yield

The “specific yield” (kWh/kWp) is the total annual energy generated per kWp installed. It is often used to help determine the financial value of an array^[25] and compare operating results from different technologies and systems. The specific yield of a plant depends on:

- The total annual irradiation falling on the collector plane. This can be increased by optimally tilting the modules or employing tracking technology.
- The performance of the module, including sensitivity to high temperatures and low light levels.
- System losses including inverter downtime.

Some module manufacturers claim much higher kWh/kWp energy yields for their products than those of their competitors. However, independent studies to determine the divergence between actual peak power and nominal power—and to correct for other technical distortions—tend to show much less of a difference.

[25] An Array is a linked collection of PV modules.

2.7

Solar PV Technology Conclusions

Photovoltaic (PV) cell technologies are broadly categorised as either crystalline or thin film. Crystalline wafers provide high efficiency solar cells but are relatively costly to manufacture; they are sub-divided into mono-crystalline or multi-crystalline silicon. Mono-crystalline silicon cells are generally the most efficient, but are also more costly than multi-crystalline.

Thin film cells provide a cheaper alternative but are less efficient. There are three main types of thin film cells:

- **Amorphous Silicon** – The low cost of a-Si makes it suitable for many applications where low cost is more important than high efficiency.
- **Cadmium Telluride** – Modules based on CdTe produce a high energy output across a wide range of climatic conditions with good low light response and temperature response coefficients.
- **Copper Indium (Gallium) Di-Selenide (CIGS/CIS)** – Commercial production of CIGS modules is in the early stages of development. However, it has the potential to offer the highest conversion efficiency of all the thin film PV module technologies.

The performance of a PV module will decrease over time due to a process known as degradation. Typically, the degradation rate is highest in the first year of operation and then it stabilises. PV modules may have a long term degradation rate of between 0.3% and 1% per annum. Banks often assume a flat rate of degradation rate of 0.5% per annum.

Modules are either mounted on fixed angle frames or on sun-tracking frames. Fixed frames are simpler to install, cheaper and require less maintenance. However, tracking systems can increase yield by up to 34%. Tracking, particularly for areas with a high direct/diffuse irradiation ratio, also enables a smoother power output.

Inverters convert DC electricity generated by the PV modules into AC electricity, ideally conforming to the local grid requirements. They are arranged either in string or central configurations. Central configuration inverters are considered to be more suitable for multi-megawatt plants. String inverters enable individual string MPPT and require less specialised maintenance skills. String configurations are becoming increasingly popular as they offer more design flexibility.

PV modules and inverters are all subject to certification, predominantly by the IEC. However, one major absence in the standards is performance and energy rating testing other than at standard testing conditions (STC). A standard is being prepared for this, which should enable easier comparison of manufacturers.

The performance ratio (PR) of a well-designed PV power plant will typically be in the region of 75% to 85%, degrading over the lifetime of the plant. The capacity factor should typically be in the region of 16%. In general, good quality PV modules may be expected to have a useful life of 25 to 30 years.

3. THE SOLAR RESOURCE

3.1 Quantifying the Resource

Site selection and planning of PV power plants requires reliable solar resource data. Power production depends linearly on the plane of array irradiance^[26], at least to a first approximation. The solar resource of a location is usually defined by the values of the global horizontal irradiation^[27], direct normal irradiation and diffuse horizontal irradiation as defined below.

- **Global Horizontal Irradiation (GHI)** – GHI is the total solar energy received on a unit area of horizontal surface. It includes energy from the sun that is received in a direct beam and from all directions of the sky when radiation is scattered off the atmosphere (diffuse irradiation). The yearly sum of the GHI is of particular relevance for PV power plants, which are able to make use of both the diffuse and beam components of solar irradiance.
- **Direct Normal Irradiation (DNI)** – DNI is the total solar energy received on a unit area of surface directly facing the sun at all times. The DNI is of particular interest for solar installations that track the sun and for concentrating solar technologies (as concentrating technologies can only make use of the direct component of irradiation).
- **Diffuse Horizontal Irradiation (DHI)** – DHI is the energy received on a unit area of horizontal surface from all directions when radiation is scattered off the atmosphere or surrounding area.

Irradiation is measured in kWh/m², and values are often given for a period of a day, a month or a year. A high long term average annual GHI is typically of most interest to PV project developers. Average monthly values are important when assessing the proportion of energy generated in each month. Figure 10 shows the annual average of GHI for India.

[26] Irradiance is the power incident on a surface per unit area. (Watts per square meter or W/m²).

[27] Irradiation is a measure of the energy incident on a unit area of a surface in a given time period. This is obtained by integrating the irradiance over defined time limits. (energy per square meter or kWh/m²)

3.2 Solar Resource Assessment

Long term annual average values of GHI and DNI can be obtained for a site by interpolating measurements taken from ground based sensors or indirectly from the analysis of satellite imagery. Ideally, historical values of daily or hourly irradiation with a spatial resolution of 10 km or less are required to generate regional solar atlases.

As the distance between a solar resource and a ground-based sensor increases, the uncertainty of interpolated irradiation values increases. Under such circumstances, satellite derived data may be preferred. The uncertainty in satellite-derived data is reducing as new models develop. The precise point at which satellite data become preferable over data interpolated from ground sensors depends on the individual case. The relative merits of these alternative data sources are discussed below.

3.2.1 Satellite Derived Data

Satellite-derived data can offer a wide geographical coverage and can often be obtained retrospectively for historical periods in which no ground-based measurements were taken. This is especially useful for assessing long term averages. A combination of analytical, numerical and empirical methods can offer half-hourly data with a nominal spatial resolution down to 2.5 km, depending on the location and field of view of the satellite.

One advantage of satellite resource assessment is that data is not susceptible to maintenance and calibration discontinuities. The same sensor is used to assess locations over a wide area. This can be particularly useful in comparing and ranking sites as bias errors are consistent.

A comparison of the GHI values shows that statistics obtained from satellite readings correspond well with ground-measured data. But it is not so in the case of DNI values. Currently, it is not so clear if this dissonance is due to the satellite methodology or the poor maintenance of ground-based measurement stations, but is likely to be a combination of both.

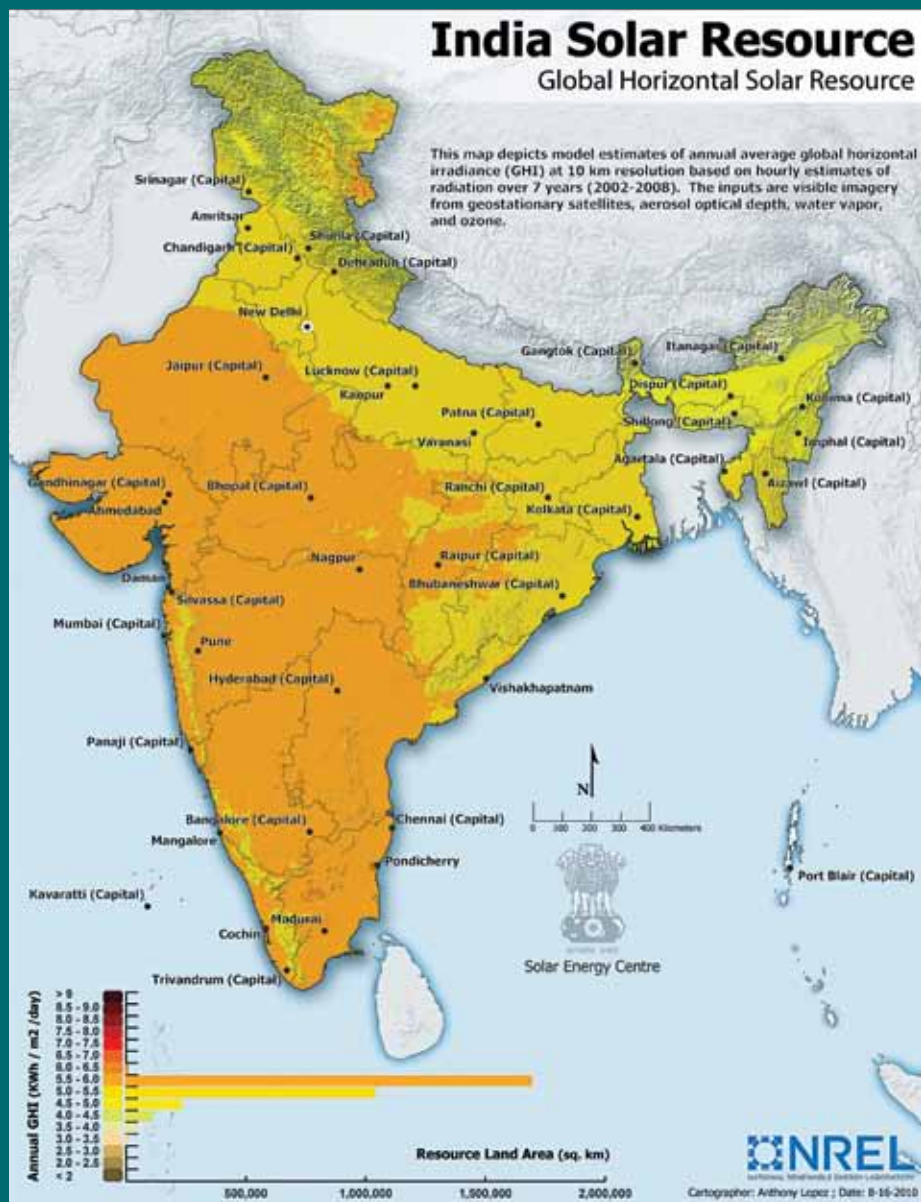

Figure 10: Annual Average Global Horizontal Irradiation^[28]

This diagram was created by the National Renewable Energy Laboratory for the Department of Energy (USA)

Efforts are underway to improve the accuracy of satellite-derived data. One way is to use more advanced techniques for the treatment of high reflectivity surfaces such as salt plains and snow-covered regions. Another technique uses updated methods for estimating the Aerosol Optical Depth (AOD), which can depend on locally generated dust, smoke from biomass burning and anthropogenic pollution.

Accurate estimates of AOD are particularly important for the calculation of DNI for concentrating solar power applications. Concentrating solar power is discussed in Appendix A – Solar CSP Annex.



Figure 11: Example Pyranometer Measuring GHI (Image courtesy: Kipp & Zonen)

[28] United States National Renewable Energy Laboratory www.nrel.com, accessed May 2010.

3.2.2 Land Based Measurement

The traditional approach to solar resource measurement is to use land-based sensors. A variety of sensor technologies is available from a number of manufacturers with differing accuracy and cost implications. The two main technology classes are:

- Thermal Pyranometers** – These are also known as solarimeters and typically consist of a black metal plate absorber surface below two hemispherical glass domes in a white metal housing. Solar irradiance warms up the metal plate in proportion to its intensity. The degree of warming, compared to the metal housing, can be measured with a thermocouple. High precision can be achieved with regular cleaning and recalibration. Since thermal pyranometers have a slow response time, they might not be able to capture rapidly varying irradiance levels due to clouds. Also, diffuse irradiance can be measured if a sun – tracking shading disc is used to block out irradiance travelling directly from the sun. An example of a pyranometer is shown in Figure 11.
- Silicon Sensors** – These are cheaper than pyranometers and consist of a PV cell, often using crystalline silicon. The current delivered is proportional to the irradiance. Temperature compensation can be used to increase accuracy but its scope is limited by the spectral sensitivity of the cell. Some wavelengths (for example long wavelength IR) may not be accurately measured, resulting in a lower irradiance measurement of up to 5% compared to thermal pyranometers.

Well maintained land-based sensors can measure the solar resource with a relative accuracy of 3-5%. Long term data from such stations may be used to calibrate satellite – derived irradiation maps. However, maintenance is very important since soiled or ill-calibrated sensors can easily yield unreliable data.

In Europe, it is not common for the solar resource to be measured at the site of a PV plant for any significant length of time, prior to construction. Energy yield predictions typically rely on historical irradiation data taken from nearby meteorological (MET) stations or derived from satellite imagery.

For locations that have a low density of MET stations and rely on satellite data, on-site resource monitoring may be considered during the feasibility stage of the project. On-site resource monitoring may be used to calibrate satellite-derived estimates, thereby reducing bias and improving accuracy. In general, up to four months of measured data can reduce existing bias, and improve the estimation of the long term mean. A further, four to eight months of measured data will improve the capability to capture seasonal variations. But the best results are obtained by monitoring for a full twelve months or longer.

3.3 Variability in Solar Irradiation

In terms of irradiation, the solar resource is inherently intermittent. In any given year, the total annual global irradiation on a horizontal plane varies from the long term average due to climatic fluctuations. This means that though the plant owner may not know the energy yield to expect in any given year, he can have a good idea of the expected yield averaged over the long term.

To help lenders understand the risks and perform a sensitivity analysis, it is important to quantify the limits of the inter-annual variation. This can be achieved by assessing the long-term irradiation data (in the vicinity of the site) sourced from nearby MET stations or satellites. At least 10 years of data are usually required to give a reasonably confident assessment of the variation. Research papers^[29] show that for southern Europe (including Spain), the coefficient of variation (standard deviation divided by the mean^[30]) is below 4%. Table 4 shows the coefficient of variation for four locations in India as derived from data provided by NASA.

[29] Uncertainties in photovoltaic electricity yield prediction from fluctuation of solar radiation. Proceedings of the 22nd European Photovoltaic Solar Energy Conference, Milano, Italy 3-7.9.2007.

[30] The coefficient of variation is a dimensionless, normalised measure of the dispersion of a probability distribution. It enables the comparison of different data streams with varying mean values.

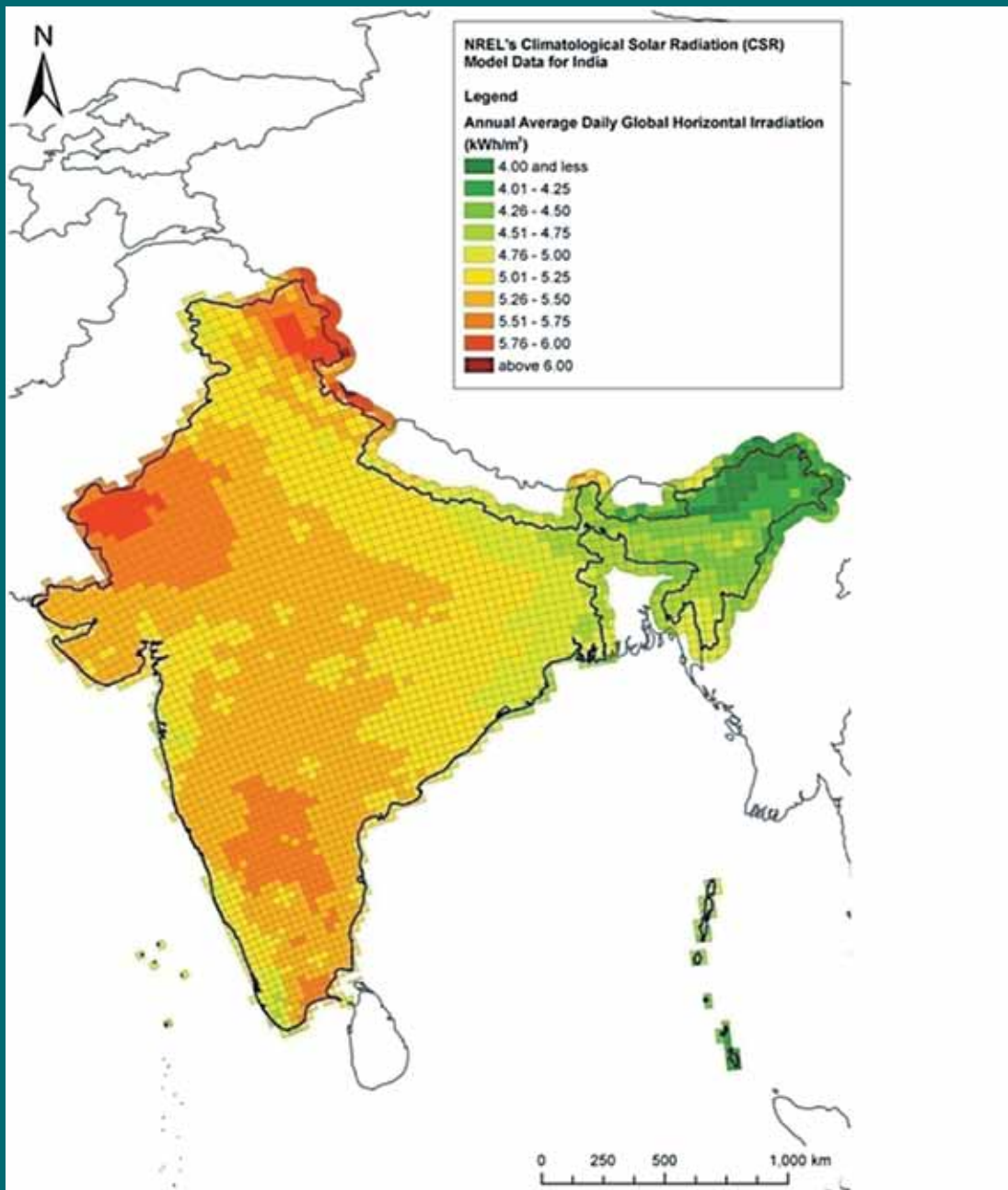

Figure 12: Annual Average Daily Global Horizontal Irradiation for India at 40 km Resolution^[31]

Table 4: Inter-Annual Variation in Solar Resource From Analysis of NASA SSE

Location	Number of years of data	Coefficient of Variation
New Delhi	22	3.4%
Mumbai	22	2.5%
Chennai	22	2.2%
Sivaganga	22	4.3%

[31] Data from United States National Renewable Energy Laboratory www.nrel.com, accessed May 2010. National boundaries shown may not necessarily accurately reflect the Indian national boundaries.

3.4 Indian Solar Resource

Data sources for solar radiation in India are of varying quality. Comparison and judicious selection of data sources by specialists in solar resource assessment is recommended while developing a project. Some of the more accessible data sources include:

- India Meteorological Department data from 23 field stations of the radiation network, measured from 1986 to 2000.
- NASA's Surface Meteorology and Solar Energy data set. This holds satellite – derived monthly data for a

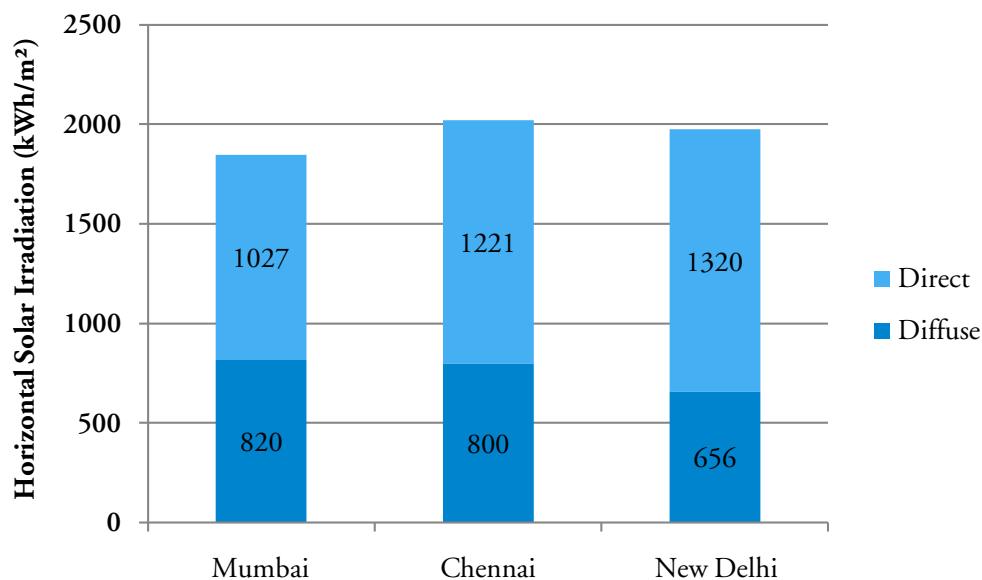

Figure 13: Annual Mean Horizontal Solar Irradiation for Three Cities in India

grid of $1^{\circ} \times 1^{\circ}$ covering the globe for a 22 year period (1984-2005). The data are considered accurate for preliminary feasibility studies of solar energy projects in India. They are also particularly useful for estimating the inter-annual variability of the solar resource.

- The METEONORM global climatological database and synthetic weather generator. This contains a database of ground station measurements of irradiation and temperature. In cases where a site is over 20 km from the nearest measurement station,

METEONORM generates climatological averages estimated by using interpolation algorithms and satellite data.

- Satellite-derived geospatial solar data products from the United States-based National Renewable Energy Laboratory (NREL). Annual average DNI and GHI, latitude tilt, and diffuse data are available at 40 km resolution for South and East Asia and at 10 km resolution for India, as shown in the examples of Figure 10 and Figure 12.

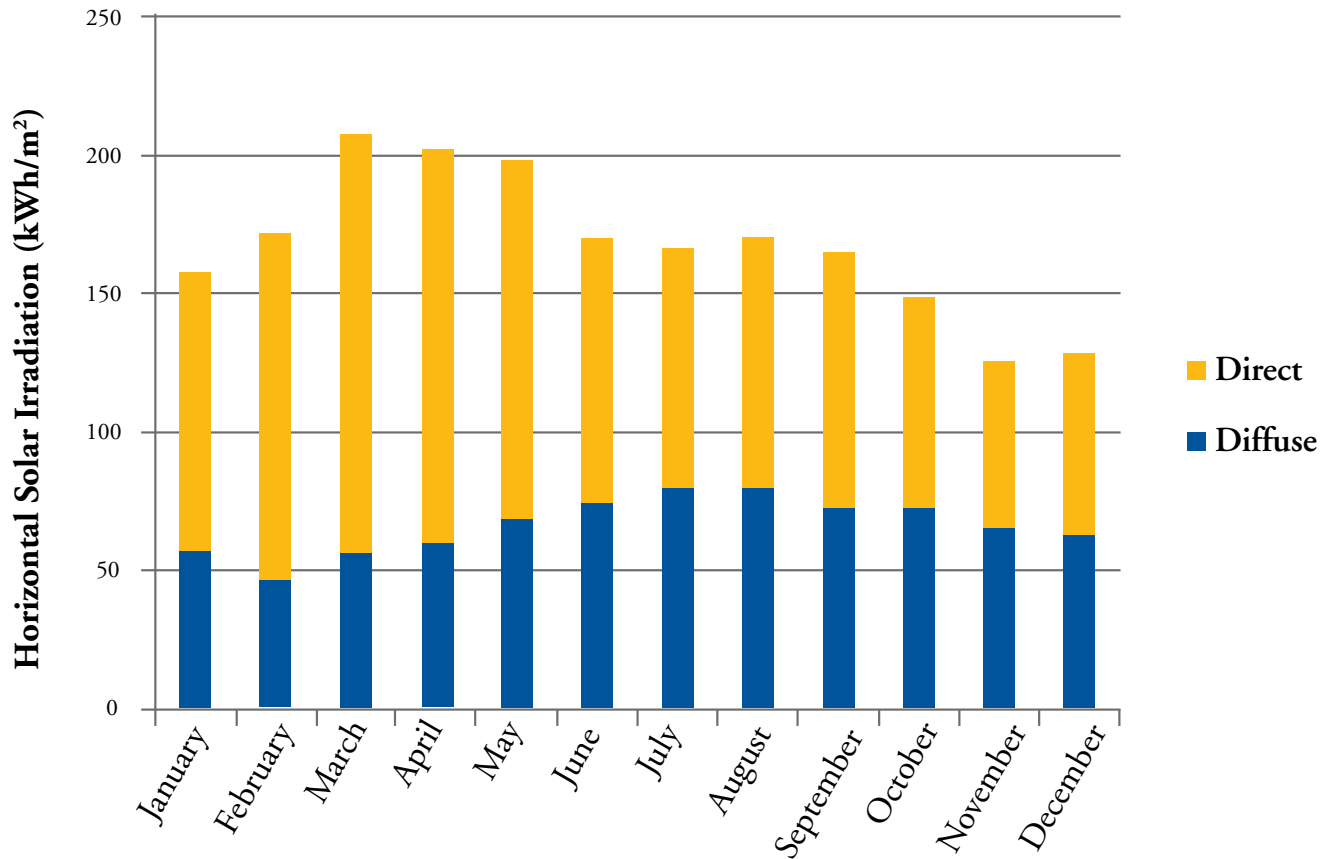

Figure 14: Monthly Diffuse and Direct Solar Irradiation in Chennai, India

Figure 13 shows the proportion of direct and diffuse radiation for three cities in India obtained from the METEONORM database using land-based sensors supervised by the World Meteorological Organisation (WMO). Due to the higher proportion of direct irradiation, it may be expected that tracking technologies will offer a greater advantage in New Delhi than in Mumbai.

Figure 14 shows how the average monthly solar irradiation varies over a year at Chennai. The energy yield and revenue of a PV power plant may be expected to vary approximately in proportion. The annual mean GHI in Chennai is 2,021 kWh/m². By optimally-orientating a fixed tilt plant, the yearly sum of global irradiation may be increased to 2,048 kWh/m². Based on this resource, a 1 MWp plant with a PR of 80% will give an AC yield of 1,638 MWh.

Case Study 1

Resource Assessment

In order to support financing, the developer of the 5 MW plant in Tamil Nadu had a basic solar resource assessment carried out. However, only one data source was used and there was no assessment made of the inter-annual variability of the resource. Nor was any analysis provided of the historical period on which the data was based. However, as has been seen globally, financing institutions are becoming more sophisticated in their analysis of solar plants and their requirements are moving towards including analysis from additional data sets.

In a competitive market, financial institutions will tend to give better terms of financing to those projects that have the lowest risk financial return. An important component of the risk assessment is the confidence that can be placed in the solar resource at the site location. Developers can reduce the perceived long term solar resource risk by:

- Comparing different data sources, assessing their uncertainty and judiciously selecting the most appropriate data for the site location.
- Assessing the inter-annual variation in the solar resource in order to quantify the uncertainty in the revenue in any given year.

There are a variety of possible solar irradiation data sources that may be assessed for the purpose of estimating the irradiation at potential solar PV sites in India. The datasets either make use of ground-based measurements at well-controlled meteorological stations or use processed satellite imagery.

The location of the 5 MW plant in Tamil Nadu was more than 200 km from the nearest MET station. It was, therefore, necessary to rely on data interpolation between distant MET stations, and on data from satellites.

The image below compares the data obtained for the site location from three such data sources. There is a significant discrepancy between them. A robust solar resource assessment would compare the data sources, discuss their uncertainty and select the data most likely to represent the long term resource at the site location.

Where there is significant uncertainty in the data sources (or in the case of large capacity plants), a short term data monitoring campaign may be considered. Short term monitoring (ideally up to one year in duration) may be used to calibrate long term satellite-derived data and increase the confidence in the long term energy yield prediction.

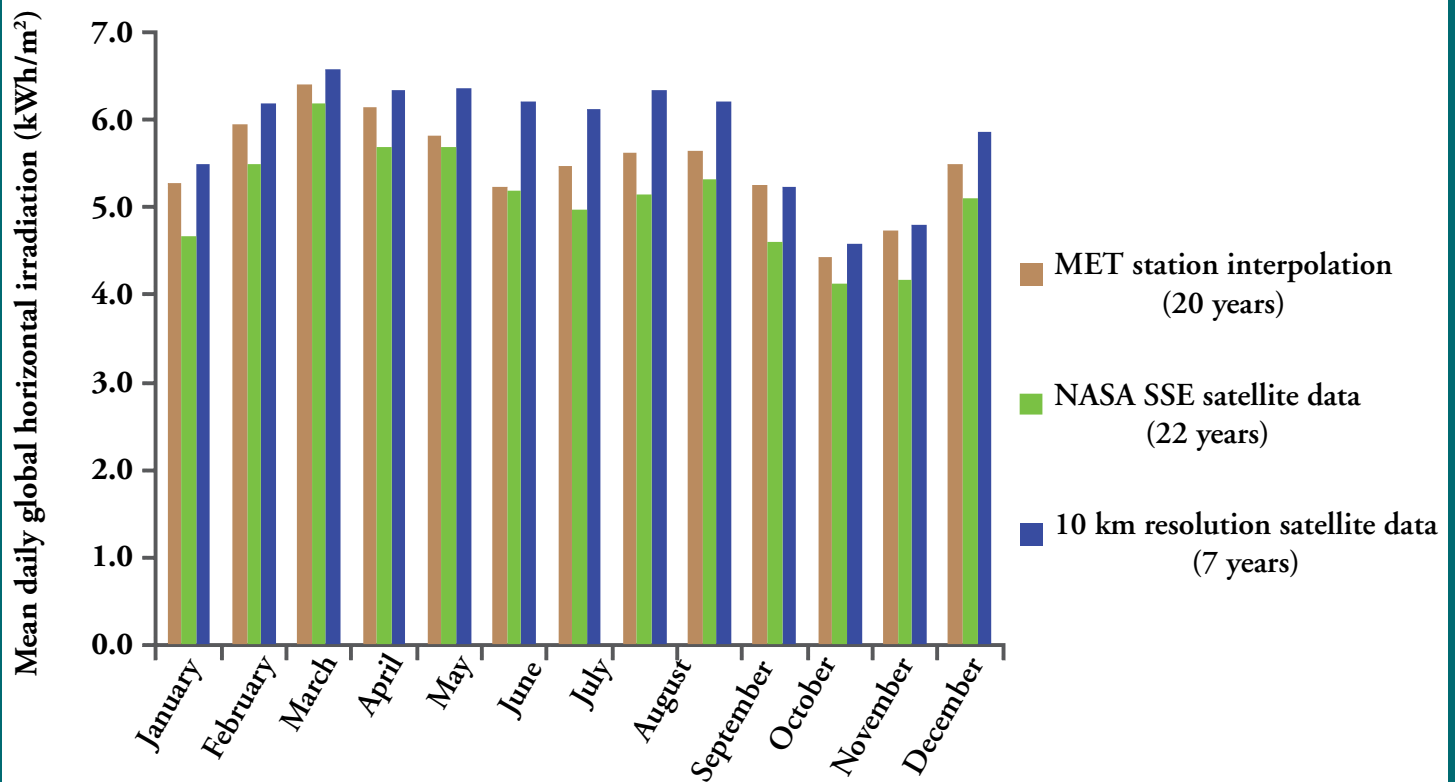

4. PROJECT DEVELOPMENT

To move from concept to construction, a project must pass through a number of development stages. The key consideration during project development is the balance of expenditure and risk. There is no definitive detailed “road map” for developing a solar PV project. The approach taken will depend on the developer’s priorities and requirements such as risk profiles or deadlines, as well as site dependent parameters.

This section outlines a general development process for a solar PV project and highlights key considerations for each stage.

4.1 Overview of Project Phases

The development process for a solar PV project can be broken down into the following stages:

- **Concept** – An opportunity (a potential PV project) is identified.
- **Pre-feasibility study** – This is the first assessment of the potential project. It is a high-level review of the main aspects of the project such as the solar resource, grid connection and construction cost in order to decide if the project is worth taking forward.
- **Feasibility study** – If the outcome of the pre-feasibility study is favourable, a detailed feasibility study can be carried out. This consists of a significantly more detailed assessment of all aspects of the project. The purpose of the feasibility study is to explore the project in enough detail for the interested parties and stakeholders to make a commitment to proceed with its development.

- **Development** – The development phase takes the project from the feasibility study to financial closure. This involves moving the project forward on a number of fronts including outline design and selection of contractors.
- **Detailed Design** – The key systems and structures will be designed in detail. This will generally be completed by a contractor.
- **Construction** – The physical construction of the project.

More detail on each of these stages is given in the following sections. However, it should be noted that in practice the development process may not follow such a simple linear progression.

4.2 Concept

The identification of a potential solar PV project generally requires:

- A project sponsor^[32].
- A potential site.
- Funds to carry out feasibility assessments.

4.3 Pre-Feasibility Study

A pre-feasibility study aims to assess if a project is worth progressing without committing significant expenditure. A pre-feasibility study should, as a minimum, include assessment of:

[32] The Sponsor(s) is (are) the party that owns the specific Project Company which is set up to develop and own a specific project or portfolio. Contracts and other agreements are entered into in the name of the Project Company. The Sponsor provides financial (and other) resources, thereby allowing the Sponsor to retain control of the project in a way that can allow it to minimise its exposure to risk.

- The project site and boundary area.
- A conceptual design of the project, including estimation of installed capacity.
- The approximate costs for development, construction and operation of the project and predicted revenue.
- Estimated energy yield.
- Grid connection – cost and likelihood of achieving connection.
- Permitting requirements and likelihood of achieving these.

In order to keep expenditure low, estimated costs are likely to be based on indicative quotes or comparisons with similar projects. Similarly, conceptual design will be based on readily available information. The method for assessing the likelihood of obtaining a grid connection or obtaining planning (or other) consents will depend on the location of the project. To start off, initial contact should generally be made with the relevant organisations.

The site and resource assessments will constrain the area likely to be viable for project use. At the pre-feasibility stage, these assessments should take the form of a desk-top study.

While a full energy yield is not required, an initial energy yield should be carried out using solar resource data and estimates of plant losses (based on nominal values seen in existing projects).

4.4 Feasibility Study

The feasibility phase will focus on the possible site or sites outlined in the pre-feasibility study. It will take into account each of the constraints in more detail and, if multiple sites are being assessed, should highlight the preferred site.

A typical scope for a feasibility study would include:

- Production of a detailed site plan.
- Calculation of solar resource and environmental characteristics (temperature and wind speed).
- Assessment of shading (horizon and nearby buildings and objects).
- Outline layout of areas suitable for PV development.
- Assessment of technology options providing cost/benefit for the project locations. This includes assessment of:
 - Module type.
 - Mounting System.
- Outline system design.
- Application for outline planning permission.
- Grid connection – more detailed assessment of likelihood, cost and timing.
- Predicted energy yields.
- Financial modelling.

The feasibility study may overlap with the development phase depending on the priorities of the developer.

4.4.1 Outline System Design

Outline system design provides a basis for all project development activities from estimating costs to tendering for contractors. It is also required for planning permission applications. While a conceptual design will have been

developed as part of the pre-feasibility study, it may be worthwhile assessing various design configurations at this stage in order to ensure that an optimised design is selected.

Specific tasks include:

- Calculation of shade and initial PV plant layout. This process of optimisation typically takes into account:
 - Shading angles.
 - O&M requirements.
 - Module cleaning strategy.
 - Tilt angle and orientation.
 - Temperature and wind profiles of the site.
 - Cable runs and electrical loss minimisation.
- Module selection. This is a selection based on the feasibility phase output, current availability and pricing in the market place.
- Inverter selection.
- Mounting frame or tracking system selection, including consideration of site specific conditions.
- Electrical cabling design and single line diagrams.
- Electrical connections and monitoring equipment.
- Grid connection design.
- Full energy yield analysis using screened solar data and the optimised layout.

4.4.2 Planning Applications

Advice on planning documentation requirements in the project area can be obtained from the local planning department or from an experienced consultant. The type of information that needs to be considered includes:

- Permits or licences required.
- Timescales for submission and response.

- Information required for submission.
- Method of submission (online or via the planning department office).
- Standard restrictions for the area of the development (for example zoning regulations).
- Process for making amendments at a later date.

An application for outline planning (or other) permission should form part of the feasibility stage. A full application should be made during the development process.

It should be stressed that regulatory requirements vary widely in different regions. The particular requirements of the Indian market are covered in detail in Section 8.3.

4.5 Development

The development phase of the project takes the project from the feasibility stage through to financial closure. The suggested scope of work in this phase consists of:

- Preparation and submission of the permit applications for the proposed solar PV project.
- Preparation and submission of a grid connection application.
- Revision of the design and planning permissions.
- Decision on contracting strategy (i.e. single EPC contract or multi-contract).
- Decision on the financing approach.
- Preparation of solar PV module tender documentation.
- Supplier selection and ranking.
- Preparation of construction tender documentation.
- Contractor selection and ranking.
- Contract negotiations.

- Completion of a bankable energy yield.
- Preparation of a financial model covering the full lifecycle of the plant.
- Completion of a project risk analysis.
- Environmental impact assessment.
- Production of a detailed project report.
- Securing financing for the project.

4.5.1 Bankable Energy Yield Prediction

In the development stage, a bank grade energy yield will be required to secure finance. It is advised that this energy yield is either carried out or reviewed by an independent specialist. This will ensure that confidence can be placed in the results and will help attract investment.

The energy yield should include:

- An assessment of the inter-annual variation and yield confidence levels.
- Consideration of site-specific factors, including soiling or snow, and the cleaning regime specified in the O&M contract.
- Full shading review of the PV generator including near and far shading.
- Detailed losses.
- A review of the proposed design to ensure that parameters are within design tolerances.

4.5.2 Environmental Impact Assessment

An Environmental Impact Assessment (EIA) is likely to be required for projects over a certain size. It is an assessment of the possible impact, positive or negative, that a proposed project may have on the environment. The EIA should consider the natural, social and economic aspects of a project's construction and operation during its lifespan.

The EIA should consider the likely environmental effects of the proposed development based upon current knowledge of the site and the surrounding environment. This information will determine what specific studies are required. The EIA should then assess ways of avoiding, reducing or offsetting any potentially significant adverse effects. The studies will also provide a baseline case that can be used in the future to determine the impact of the project.

Guidance on the significance of impacts is mainly of a generic nature. However, it is broadly accepted that this significance reflects the relationship between a number of factors:

- The magnitude or severity of an impact (that is, the actual change taking place to the environment).
- The importance or value of the affected resource or receptor.
- The duration involved.
- The reversibility of the effect.
- The number and sensitivity of receptors.

The significance, importance or value of a resource is generally judged on the following criteria:

- The land's designated status within the land use planning system.
- The number of individual receptors.
- An empirical assessment on the basis of characteristics such as rarity or condition.
- Ability to absorb change.

It is recommended that the EIA is carried out by an experienced Environmental Impact Assessor or similarly qualified person.

4.5.3 Detailed Project Report

The main output of the development phase will be a detailed project report. This will be used to secure finance from banks or investors (more information on financing is in Section 13). The information should be project-specific including all relevant information in a professional and clear format. The items detailed below give examples of the information that should be included:

- Site layout (showing the location of modules, inverters and buildings). Indicative plans showing:
 - Mounting frame and module layout.
 - Inverter locations and foundations/housings.
 - Security measures.
 - Buildings and other infrastructures.
- Initial electrical layouts:
 - Schematics of module connections through to the inverter.
 - Single line diagrams showing anticipated cable routes.
 - Grid connection and potential substation requirements.
- Bill of materials for major equipment.
- Energy yield analysis.
 - Losses assumed with regard to the energy yield forecast.
- Financial model inputs including:
 - Long term O&M costs and contingencies (up to the end of the design life and/or debt term).
 - Availability assumptions.
 - Degradation of module performance assumptions.

- Spare parts inventory cost.
- Connection cost for electricity and services.
- Details of the permitting and planning status.
- Environmental impact assessment, restrictions and mitigation plans.

4.5.4 Contract Strategy

There are two main contracting strategies that a developer may consider: multi-contract and single EPC contract.

A multi-contract approach will require significantly more project management from the developer during the design and construction phase. However, it will be cheaper than an EPC approach.

The higher cost EPC option transfers significant risks from the developer to the contractor. If this option is chosen, then the detailed design stage will be completed by the EPC contractor. The developers will need to ensure that the tender documentation is accurate and includes all the required information and systems. It will be easier and more economical to make changes before the contracts are signed. If the developer has little or no experience, or is unsure of any aspect of the project, it is advised that they seek advice from an experienced consultant in that area.

There is no single preferred contracting approach. The approach taken will depend on the experience, capabilities and cost sensitivity of the developer.

4.6 Detailed Design

This phase will prepare the necessary detail and documentation to allow construction of the solar PV plant to be carried out. The following documentation will be prepared:

- Detailed layout design.
- Detailed civil design (buildings, foundation, access roads).
- Electrical detailed design.
- Revised energy yield.
- Construction plans.
- Project schedule.
- Interface matrix.
- Commissioning plans.

The key electrical systems must be designed in rigorous detail. This will include equipment required for protection, earthing, and interconnection to the grid. The following designs and specifications should be prepared:

- Overall single line diagrams.
- MV & LV switchgear line diagrams.
- Protection systems.
- Interconnection systems and design.
- Auxiliary power requirements.
- Control systems.

The civil engineering items should be developed to a level suitable for construction. These will include designs of array foundations and buildings, as well as roads and infrastructure required for implementation and operation. The design basis criteria should be determined in accordance with national standards. The wind loadings should be calculated to ensure that the design will be suitable for the project location.

5. SITE SELECTION

5.1 Introduction

Selecting a suitable site is a crucial component of developing a viable solar PV project. There are no clear cut rules for site selection. Viable projects have been developed in locations that may seem unlikely on first look, such as on high gradient mountain slopes, within wind farms and on waste disposal sites. In general, the process of site selection must consider the constraints and the impact they will have on the cost of the electricity generated. The main constraints that need to be assessed include:

- Solar resource.
- Local climate.
- Available area.
- Land use.
- Topography.
- Geotechnical.
- Geopolitical.
- Accessibility.
- Grid connection.
- Module soiling.
- Water availability.
- Financial incentives.

“Showstoppers” for developing a utility scale PV power plant in a specific location may include constraints due to a low solar resource, low grid capacity or insufficient area. However, a low solar resource could be offset by high local financial incentives, making a project viable. A similar balancing act applies to the other constraints. These are discussed further below.

5.2 Site Selection Constraints

5.2.1 Solar Resource

A high average annual GHI is the most basic consideration for developing a solar PV project. The higher the resource, the greater the energy yield per kWp installed. When assessing the GHI at a site, care must be taken to minimise any shading that will reduce the irradiation actually received by the modules. Shading could be due to mountains or buildings on the far horizon, or mutual shading between rows of modules, or shading near the location due to trees, buildings or overhead cabling. Avoiding shading is critical as even small areas of shade may significantly impair the output of a module or string of modules. The loss in output could be more than predicted by simply assessing the proportion of the modules that are shaded.

When assessing shading, it must be remembered that the path the sun takes through the sky changes with the seasons. An obstacle that provides significant shading at mid-day in December may not provide any shading at all at mid-day in June. The shading should be assessed using the full sun-path diagram for the location.

5.2.2 Area

The area required per kWp of installed power varies with the technology chosen. The distance between rows of modules (the pitch) required to avoid significant inter-row shading varies with the site latitude. Sites should be chosen with sufficient area to allow the required power to be installed without having to reduce the pitch to levels that cause unacceptable yield loss.

Depending on the site location (latitude) and the type of PV module selected (efficiency), a well-designed PV power plant with a capacity of 1 MWp developed in India is estimated to require between one and two hectares (10,000 to 20,000 m²) of land. A plant using lower efficiency CdTe thin film modules may require approximately 40 to 50% more space than a plant using poly-crystalline modules. Figure 15 shows a large ground mounted plant.

5.2.3 Climate

In addition to a good solar resource, the local climate should not suffer from extremes of weather that will increase the risk of damage or downtime. Weather events that may need consideration include:

- **Flooding** – May increase the risk of erosion of support structure and foundations, depending on geo-technical conditions.
- **High wind speeds** – The risk of a high wind event exceeding the plant specifications should be assessed. Locations with a high risk of damaging wind speeds should be avoided. Fixed systems do not shut down at high wind speeds, but tracking systems must shut down in safe mode when speeds of 16-20 m/s are exceeded.
- **Snow** – Snow settling on modules can significantly reduce annual energy yield if mitigating measures are not taken. If the site is prone to snow, then one has to consider factors such as extra burden on the mounting structures, the loss in energy production and the additional cost of higher specification



Figure 15: Large Scale PV Plant

modules or support structures. The cost of removing the snow needs to be weighed against the loss in production and the likelihood of further snowfall. The effects of snow can be mitigated by a design with a high tilt angle and frameless modules. The design should also ensure that the bottom edge of the module is fixed higher than the average snow level for the area. A site that has regular coverings of snow for a long period of time may not be suitable for developing a solar PV plant.

- **Temperature** – The efficiency of a PV power plant reduces with increasing temperature. If a high temperature site is being considered, mitigating measures should be included in the design and technology selection. For instance, it would be better to choose modules with a low temperature coefficient for power.

5.2.4 Topography

Ideally, the site should be flat or on a slight south facing (in the northern hemisphere) slope. Such topography makes installation simpler, and reduces the cost of technical modifications required to adjust for undulations in the ground. With additional cost and complexity of installation, mounting structures can be designed for most locations. In general, the cost of land must be weighed against the cost of designing a mounting structure and installation time.

5.2.5 Geotechnical

A geotechnical survey of the site is recommended prior to final selection. The purpose is to assess the ground conditions in order to take the correct design approach, and to ensure that the mounting structures will have adequate foundations. The level of the geotechnical survey required will depend on the foundation design that is envisaged.

Best practice dictates that either boreholes or trial pits are made at regular intervals and at a depth appropriate for the foundation design. The boreholes or trial pits would typically assess:

- The groundwater level.
- The resistivity of the soil.
- The load-bearing properties of the soil.
- The presence of rocks or other obstructions.
- The soil pH and chemical constituents in order to assess the degree of corrosion protection required and the properties of any cement to be used.

The geotechnical study may also be expected to include an assessment of the risk of seismic activity and the susceptibility to frost, erosion and flooding.

5.2.6 Access

The site should allow access for trucks to deliver plant and construction materials. This may require upgrading existing roads or building new ones. At a minimum, access roads should be constructed with a gravel chip finish or similar. The closer the site is to a main access road, the lower the cost of adding this infrastructure. Safe packaging of the modules and their susceptibility to damage in transport must also be carefully considered.

The site should be in a secure location where there is little risk of damage from either people or wildlife. It should ideally be in a location where security and maintenance personnel can respond quickly to any issue and this requirement should be stipulated in the maintenance contract.

5.2.7 Grid Connection

A grid connection of sufficient capacity is required to enable the export of power. The viability of grid connection will depend on three main factors: capacity, availability and proximity. These factors should be considered thoroughly at an early stage of a project; otherwise, the costs could become prohibitive if the site is later found to be in an unfavourable area for grid connection.

- **Capacity** – The capacity for the grid to accept exported power from a solar plant will depend on the existing network infrastructure and current use of the system. The rating of overhead lines, cables and transformers will be an important factor in assessing the connection capacity available. Switchgear fault levels and protection settings may also be affected by the connection of a generation plant. In cases where a network does not have the existing capacity to allow connection, there are two options available: 1) to reduce peak power export to the allowable limits of the network or 2) to upgrade the network to allow the desired export capacity. Network upgrade requirements will be advised by the network operator. But some aspects of that upgrade can be carried out by contractors other than the network operator. Initial investigation into network connection point capacity can often be carried out by reviewing published data. However, discussion with the network operator will be required to fully establish the scope of work associated with any capacity upgrades.
- **Proximity** – A major influence on the cost of connecting to the grid will be the distance from the site to the grid connection point. Sites should be at locations where the cost of grid connection does not adversely affect project economics. Besides, a higher connection voltage will entail increased cost of electrical equipment such as switchgear and transformers, as well as a higher conductor specification. A higher voltage is also likely to increase the time taken to provide the connection resulting in a longer development period.
- **Availability** – The grid availability describes the percentage of time that the network is able to export power from the solar PV plant. The annual energy

yield from a plant may be significantly reduced if the grid has significant downtime. This may have adverse effects on the economics of the project. Availability statistics should be requested from the network operator to establish the expected downtime of the network. In developed areas, the availability of the grid is usually very high.

5.2.8 Land Use

Solar PV power plants will ideally be built on low value land. If the land is not already owned by the developer, then the cost of purchase or lease needs to be considered. The developer must purchase the land or rights for the duration of the project. Besides access to the site, provision of water, electricity supplies and the rights to upgrade access roads must be considered along with relevant land taxes.

Since government permission will be required to build a solar plant, it is necessary to assess the site in line with the local conditions imposed by the relevant regulatory bodies. If the land is currently used for agricultural purposes, then it may need to be re-classified for “industrial use” with cost and time implications—and the possibility of outright rejection.

The future land use of the area must also be taken into account. It is likely that the plant will be in operation for at least 25 years. As such, extraneous factors need to be considered to assess the likelihood of their impact on energy yield. For example, the dust associated with building projects could have significant impact on the energy yield of the plant.

Locating the plant in an environmentally sensitive area should be avoided. Government stipulated environmental impact assessments or plant/wildlife studies will slow down and potentially stop the development of a project.

Any trees on the project site and surrounding land may need to be felled and removed, with associated cost.

Clearances from the military may be required if the site is in or near a military-sensitive area. Glare from solar modules can affect some military activities.

5.2.9 Module Soiling

If the modules are soiled by particulates, then the efficiency of the solar plant could be significantly reduced. It is, therefore, important to take into account local weather, environmental, human and wildlife factors while determining the suitability of a site for a solar PV plant. The criteria should include:

- Dust particles from traffic, building activity, agricultural activity or dust storms.
- Module soiling from bird excreta. Areas close to nature reserves, bird breeding areas and lakes should be carefully assessed.

Soiling of modules may require an appropriate maintenance and cleaning plan at the site location.

5.2.10 Water Availability

Clean, low mineral content water is preferred for cleaning modules. A mains water supply, ground water, stored water or access to a mobile water tank may be required; the cost of the various options will have an impact on the project economics. The degree to which water availability is an issue will depend upon the expected level of module-soiling, the extent of natural cleaning due to rainfall and the required cleaning frequency.

5.2.11 Financial Incentives

Financial incentives (such as feed-in tariffs or tax breaks) in different countries, or regions within countries, have a strong bearing on the financial viability of a project. Such incentives could outweigh the costs associated with one or more of the site selection constraints.

6. ENERGY YIELD PREDICTION

An important step in assessing project feasibility and attracting finance is to calculate the electrical energy expected from the PV power plant. The energy yield prediction provides the basis for calculating project revenue. The aim of an energy yield analysis is to predict the average annual energy output for the lifetime of the proposed power plant. Typically, a 25 to 30 year lifetime is assumed.

The level of accuracy needed for the energy yield prediction depends on the stage of project development. For example, a preliminary indication of the energy yield can be carried out using solar resource data and estimates of plant losses based on nominal values seen in existing projects. For a more accurate energy yield prediction, software could be used to illustrate detailed plant specifications and three-dimensional modelling of the layout. Modelling will also help assess shading losses within time-step simulation.

To accurately estimate the energy produced from a PV power plant, information is needed on the solar resource and temperature conditions of the site in addition to the layout and technical specifications of the plant components. Sophisticated software is often used to model the complex interplay of temperature, irradiance, shading and wind-induced cooling on the modules. While a number of software packages can predict the energy yield of a PV power plant at a basic level, financiers generally require an energy yield prediction carried out by a suitable expert.

Typically, the procedure for predicting the energy yield of a PV plant using time-step (hourly or sub-hourly) simulation software will consist of the following steps:

1. Sourcing modelled or measured environmental data such as irradiance, wind speed and temperature from land-based meteorological stations or satellite imagery (or a combination of both). This results in a time series of “typical” irradiation on a horizontal plane at the site location along with typical environmental conditions.
2. Calculating the irradiation incident on the tilted collector plane for a given time step.
3. Modelling the performance of the plant with respect to varying irradiance and temperature to calculate the energy yield prediction in each time step.
4. Applying losses using detailed knowledge of the inverters, PV module characteristics, the site layout, DC and AC wiring, module degradation, downtime and soiling characteristics.
5. Applying statistical analysis of resource data and assessing the uncertainty in input values to derive appropriate levels of uncertainty in the final energy yield prediction.

These steps are described in more detail in the following sections.

6.1 Irradiation on Module Plane

In order to predict the solar resource over the lifetime of a project, it is necessary to analyse historical data for the site. These data are typically given for a horizontal plane. The assumption is that the future solar resource will follow the same patterns as the historical values. Historical data may be obtained from land-based measurements or from information obtained from satellite imagery as described in Section 3.2.1 Data in hourly or sub-hourly time steps are preferred. Statistical techniques can be used to convert average monthly values into simulated hourly values if these are not immediately available.

Horizontal plane irradiation may be divided into its diffuse and direct components. Models are used to calculate the resource on the specific plane at which the modules are tilted. Part of this calculation will take into account the irradiance reflected from the surroundings towards the modules. The degree to which the ground is able to diffusely reflect radiation is quantified by the albedo values, which vary according to surface properties. A higher albedo factor translates into

greater reflection and so higher levels of diffuse irradiation. For example, fresh grass has an albedo factor of 0.26, reducing down to a minimum of approximately 0.15 when dry. Asphalt has a value between 0.09 and 0.15 or 0.18 if wet.

6.2 Performance Modelling

Sophisticated simulation software is used to predict the performance of a PV power plant in time steps for a set of conditions encountered in a typical year. This allows a detailed simulation of the efficiency with which the plant converts solar irradiance into AC power and the losses associated with the conversion. Some of these losses may be calculated within the simulation software, others are based on extrapolations of data from similar PV plants and analysis of the site conditions.

Depending on specific site characteristics and plant design, losses may be caused by any of the factors described in Table 5. Energy yield prediction reports should consider and (ideally) quantify each of these losses. In individual cases, some of the losses may be negated or considered in logical groupings.

6.3 Energy Yield Prediction Results

The predicted annual energy yield may be expressed within a given confidence interval. A P90 value is the annual energy yield prediction that will be exceeded with 90% probability; P75 is the yield that will be exceeded with 75% probability; while P50, the expected value, is the annual energy yield prediction that will be exceeded with 50% probability. Good quality energy yield reports used by investors will give the P50 and P90 energy yield prediction values as a minimum.

6.4 Uncertainty in the Energy Yield Prediction

The uncertainty of energy yield simulation software depends on each modelling stage and on the uncertainty in the input variables. Modelling software itself can introduce uncertainty of 2% to 3%.

The typical relative accuracy of measurements at meteorological (MET) stations by a well-maintained pyranometer is 3-5%. This represents the upper limit in accuracy of resource data obtained through MET stations. However, in many cases, the presence of a MET station at the project location (during preceding years) is unlikely. If this is the case, solar resource data will likely have been obtained using satellites or interpolation as described in Section 3.2. This will increase the uncertainty in the resource data depending on the quality of the satellite or the distance from a well maintained MET station. In general, resource data uncertainty of 7.5%^[33] or higher may be expected.

Uncertainty in other modelling inputs include estimates in downtime, estimates in soiling, uncertainty in the inter-annual variation in solar resource and errors due to module specifications not accurately defining the actual module characteristics.

The energy yield depends linearly, to a first approximation, on plane of array irradiance. Therefore uncertainty in the resource data has a stronger bearing on the uncertainty in the yield prediction than does the accuracy of PV modelling. Total uncertainty figures of up to 10% may be expected. A good energy yield report will quantify the uncertainty for the specific site location.

[33] "Quality of Meteoronorm Version 6.0", Jan Remund, World Renewable Energy Congress 2008.

Table 5: Losses in a PV Power Plant

Loss	Description
Air pollution	The solar resource can be reduced significantly in some locations due to air pollution from industry and agriculture.
Shading	Due to mountains or buildings on the far horizon, mutual shading between rows of modules and near shading due to trees, buildings or overhead cabling.
Incident angle	The incidence angle loss accounts for radiation reflected from the front glass when the light striking it is not perpendicular. For tilted PV modules, these losses may be expected to be larger than the losses experienced with dual axis tracking systems, for example.
Low irradiance	The conversion efficiency of a PV module generally reduces at low light intensities. This causes a loss in the output of a module compared with the standard conditions at which the modules are tested (1,000W/m ²). This 'low irradiance loss' depends on the characteristics of the module and the intensity of the incident radiation.
Module temperature	The characteristics of a PV module are determined at standard temperature conditions of 25°C. For every degree rise in Celsius temperature above this standard, crystalline silicon modules reduce in efficiency, generally by around 0.5%. In high ambient temperatures under strong irradiance, module temperatures can rise appreciably. Wind can provide some cooling effect which can also be modelled.
Soiling	Losses due to soiling (dust and bird droppings) depend on the environmental conditions, rainfall frequency and on the cleaning strategy as defined in the O&M contract. This loss can be relatively large compared to other loss factors but is usually less than 4%, unless there is unusually high soiling or problems from snow settling on the modules for long periods of time. The soiling loss may be expected to be lower for modules at a high tilt angle as inclined modules will benefit more from the natural cleaning effect of rainwater.

Table 5: Losses in a PV Power Plant

Loss	Description
Module quality	Most PV modules do not match exactly the manufacturer's nominal specifications. Modules are sold with a nominal peak power and a guarantee of actual power within a given tolerance range. The module quality loss quantifies the impact on the energy yield due to divergences in actual module characteristics from the specifications.
Module mismatch	Losses due to "mismatch" are related to the fact that the modules in a string do not all present exactly the same current/voltage profiles; there is a statistical variation between them which gives rise to a power loss.
DC cable resistance	Electrical resistance in the cable between the modules and the input terminals of the inverter give rise to ohmic losses (I^2R). This loss increases with temperature. If the cable is correctly sized, this loss should be less than 3% annually.
Inverter performance	Inverters convert from DC into AC with an efficiency that varies with inverter load.
AC losses	This includes transformer performance and ohmic losses in the cable leading to the substation.
Downtime	Downtime is a period when the plant does not generate due to failure. The downtime periods will depend on the quality of the plant components, design, environmental conditions, diagnostic response time and the repair response time.

Table 5: Losses in a PV Power Plant

Loss	Description
Grid availability and disruption	The ability of a PV power plant to export power is dependent on the availability of the distribution or transmission network. Typically, the owner of the PV power plant will not own the distribution network. He, therefore, relies on the distribution network operator to maintain service at high levels of availability. Unless detailed information is available, this loss is typically based on an assumption that the local grid will not be operational for a given number of hours/days in any one year, and that it will occur during periods of average production.
Degradation	The performance of a PV module decreases with time. If no independent testing has been conducted on the modules being used, then a generic degradation rate depending on the module technology may be assumed. Alternatively, a maximum degradation rate that conforms to the module performance warranty may be considered.
MPP tracking	The inverters are constantly seeking the maximum power point (MPP) of the array by shifting inverter voltage to the MPP voltage. Different inverters do this with varying efficiency.
Curtailed tracking	Yield loss due to high winds enforcing the stow mode of tracking systems.
Auxiliary power	Power may be required for electrical equipment within the plant. This may include security systems, tracking motors, monitoring equipment and lighting. It is usually recommended to meter this auxiliary power requirement separately.
Grid Compliance Loss	This parameter has been included to draw attention to the risk of a PV power plant losing energy through complying with grid code requirements. These requirements vary on a country to country basis.

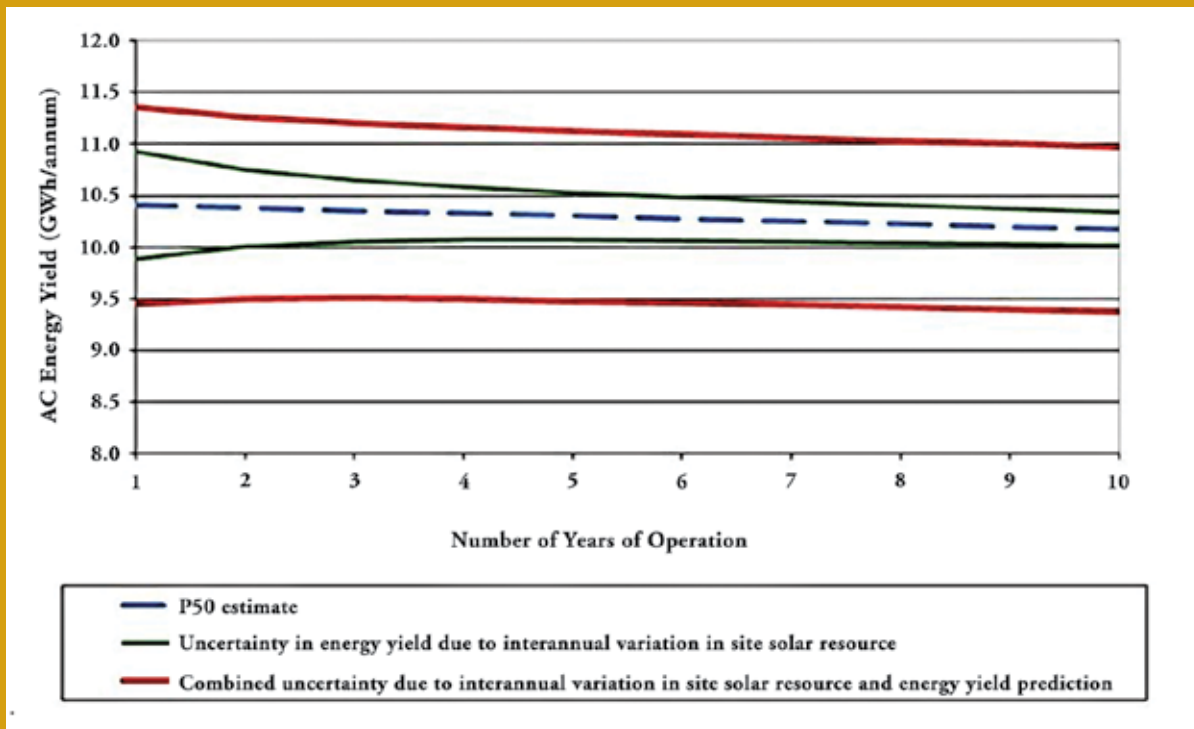

Figure 16: Uncertainty in Energy Yield Prediction

Figure 16 represents the typical combined uncertainties in the yield prediction for a PV power plant. The dashed blue line shows the predicted P50 yield. The green lines represent uncertainty in energy yield due to inter-annual variability in solar resource. The solid red lines represent the total

uncertainty in energy yield when inter-annual variability is combined with the uncertainty in the yield prediction. The total uncertainty decreases over the lifetime of the PV plant. The lower limit on the graph corresponds to the P90 and the upper limit corresponds to the P10.

Case Study 2

Energy Yield Prediction

The developer of a the 5MW plant in Tamil Nadu required a solar energy yield prediction to confirm project feasibility and assess likely revenues. The developer did not consider the range of available input data or conduct a long term yield prediction over the life of the project; both of these would have been useful to derive a more accurate yield figure, particularly for potential project financiers.

The developer sourced global horizontal irradiation data for the site location (see case study 1). Commercially available software was used to simulate the complex interactions of temperature and irradiance impacting the energy yield. This software took the plant specifications as input and modelled the output in hourly time steps for a typical year. Losses and gains were calculated within the software. These included:

- Gain due to tilting the module at 10°.
- Reflection losses (3.3%).
- Losses due to a lower module efficiency at low irradiance levels (4.2%).
- Losses due to temperatures above 25°C (6%).
- Soiling losses (1.1%).
- Losses due to modules deviating from their nominal power (3.3%).
- Mismatch losses (2.2%).
- DC Ohmic losses (1.8%).
- Inverter losses (3.6%).

The software gave an annual sum of electrical energy expected at the inverter output in the first year of operation. Although this is a useful indicative figure, an improved energy yield prediction would also consider:

- Inter-row shading losses (by setting up a 3D model).
- Horizon shading, if any.
- Near shading from nearby obstructions including poles, control rooms and switch yard equipment.
- AC losses.
- Downtime and grid availability.
- Degradation of the modules and plant components over the lifetime of the plant.

The results will ideally show the expected output during the design life of the plant and assess the confidence in the energy yield predictions given by analysing:

- The uncertainty in the solar resource data used.
- The uncertainty in the modelling process.
- The inter-annual variation in the solar resource.

The energy yield prediction for the 5MW plant was provided as a first year P50 value (the value expected with 50% probability in the first year) excluding degradation. The confidence that can be placed in the prediction would typically be expressed by the P90 value, the annual energy yield prediction that will be exceeded with 90% probability.

Projects typically, have a financing structure that requires them to service debt once or twice a year. The year on year uncertainty in the resource is therefore taken into account by expressing a “one year P90”. A “ten year P90” includes the uncertainty in the resource as it varies over a ten-year period. The exact requirement will depend on the financial structure of the project and the requirements of the financing institution.

7. PLANT DESIGN

Designing a megawatt-scale PV power plant is a complex process that requires considerable technical experience and knowledge. There are many compromises that need to be made in order to achieve the optimum balance between performance and cost. This section highlights some of the key issues that need to be considered when designing a PV plant.

7.1 Technology Selection

7.1.1 Modules

While certification of a module to IEC/CE/UL standards (as described in Section 2.3.6) is important, it says very little about the performance of the module under field conditions of varying irradiance and temperature. It is also relatively difficult to find comprehensive and independent module performance comparisons. In addition, modules tested under a specific set of conditions of irradiance, temperature and voltage, with a specific inverter, may perform very differently under alternative conditions with a different inverter.

This makes choosing a module a more difficult process than it may first appear. Many developers employ the services of an independent consultant for this reason. When choosing modules, the following key aspects should be considered:

- The aim is to keep the levelised cost of electricity^[34] (LCOE) at a minimum. When choosing between high efficiency-high cost modules and low efficiency-low cost modules, the cost and availability of land and plant components will have an impact. High efficiency modules require significantly less land, cabling and support structures per MWp installed than low efficiency modules.
- When choosing between module technologies such as mono-crystalline silicon, multi crystalline silicon and

thin film amorphous silicon, it should be realised that each technology has examples of high quality and low quality products from different manufacturers.

- Different technologies have a differing spectral response and so will be better suited for use in certain locations, depending on the local light conditions.
- Amorphous silicon modules generally perform better under shaded conditions than crystalline silicon modules. Many of them show a better response in low light levels.
- The nominal power of a module is given with a tolerance. Some modules may be rated with a $\pm 5\%$ tolerance while others are given with a $\pm 3\%$ tolerance. Some manufacturers routinely provide modules at the lower end of the tolerance, while others provide modules that achieve their nominal power or above (positive tolerance).
- When ordering a large number of modules, it is recommended to have a sample of modules independently tested to establish the tolerance.
- The value of the temperature coefficient of power will be an important consideration for modules installed in hot climates.
- The degradation properties and long term stability of modules should be understood. The results of independent testing of modules can sometimes be found in scientific journals or papers from research institutes.
- The manufacturers' warranty period is useful for distinguishing between modules but care should be taken with the power warranty. Some manufacturers offer as guarantee of performance the percentage of the peak power for a given duration; others give it as a percentage of the minimum peak power (that is, the peak power minus the tolerance).
- Frameless modules may be more suitable for locations that experience snow, as snow tends to slide off these modules more easily.

[34] The cost per kWh of electricity generated that takes into account the time value of money.

- Other parameters important for selection of modules include: cost (\$/Wp), lifetime, and maximum system voltage.

7.1.2 Quality Benchmarks

- **Product guarantee** – In the EU, manufacturers are legally bound to provide a product guarantee ensuring that modules will be fully functional for a minimum of 2 years. Some companies guarantee a longer period, with 5-6 years being the usual duration.
- **Power guarantee** – In addition to the product guarantee, most manufacturers grant nominal power guarantees. These vary between manufacturers but a typical power guarantee stipulates that the modules will deliver 90% of the original nominal power after 10 years and 80% after 25 years. So far no module manufacturer has offered a power output guarantee beyond 25 years. The conditions listed in both the power guarantee and product guarantee are important, and vary between manufacturers.
- **Lifetime** – Good quality modules with the appropriate IEC certification have a design life in excess of 25 years. Beyond 30 years, increased levels of degradation may be expected. The lifetime of crystalline modules has been proven in the field. Thin film technology lifetimes are currently unproven and rely on accelerated lifetime laboratory tests, but are expected to be in the order of 25-30 years also.

The module data sheet format and the information that should be included has been standardised and is covered by EN 50380, which is the “data sheet and nameplate information for photovoltaic modules”. An example of the information expected in a data sheet is provided in Table 6.

Table 6: Comparison of Module Technical Specifications at STC

Manufacturer	Xxxx
Module Model	Xxxx
Nominal power (P_{MPP})	210 Wp
Power tolerance	±3%
Voltage at P_{MAX} (V_{MPP})	26.5 V
Current at P_{MAX} (I_{MPP})	7.93 A
Open circuit voltage (V_{OP})	33.2 V
Short circuit current (I_{SC})	8.54 A
Maximum system voltage	1000 VDC
Module efficiency	14.33%
Operating temperature	-40°C to +85°C
Temperature coefficient of P_{MPP}	-0.41%/°C
Dimensions	1480×990×50 mm
Module area	1.47 m ²
Weight	18 kg
Maximum load	5400 Pa
Product warranty	5 years
Performance guarantee	90%: after 10 years; 80%: after 25 years

7.1.2 Inverters

No single inverter concept is best for all situations. In practice, the local conditions and the system components have to be taken into account to tailor the system for the specific application. Different solar PV module technologies and layouts may suit different inverter types. So care needs to be taken in the integration of modules and inverters to ensure optimum performance and lifetime.

Among the major selection criteria for inverters, the financial incentive scheme and the DC-AC conversion

efficiency are major inverter selection criteria, directly affecting the annual revenue of the solar PV plant. It is also important to bear in mind that efficiency varies according to a number of factors. Of them, DC input voltage and percentage load are the two dominant factors. Several other factors should inform inverter selection, including site temperature, product reliability, maintainability, serviceability and total cost of ownership. A thorough financial analysis is required to determine the most cost-effective inverter option. Many of the inverter selection criteria listed in Table 7 may feed into this analysis.

Table 7: Inverter Selection Criteria

Criterion	Description
Incentive scheme	Banding of financial incentive mechanisms may have an influence on the choice of inverter. For example, feed-in tariff (FiT) schemes might be tiered for different plant sizes which may, in turn, influence the inverter size.
Project size	Size influences the inverter connection concept. Central inverters are commonly used in large solar PV plants.
Performance	High efficiency inverters should be sought. The additional yield usually more than compensates for the higher initial cost. The way the efficiency has been defined should be carefully considered. Consideration must also be given to the fact that efficiency changes with DC input voltage, percentage of load, and several other factors.
MPP range	A wide MPP range allows flexibility and facilitates design.
3-phase or single phase output	National electrical regulations might set limits on the maximum power difference between the phases in the case of an asymmetrical load. For example, this limit is 4.6 kVA in the German regulations.
Module technology	The compatibility of thin-film modules with transformer-less inverters should be confirmed with manufacturers.

Table 7: Inverter Selection Criteria

Criterion	Description
National and international regulations	A transformer inverter must be used if galvanic isolation is required between the DC and AC sides of the inverter.
Grid code	The grid code affects inverter sizing and technology. The national grid code might require the inverters to be capable of reactive power control. In that case, over-sizing inverters slightly could be required. The grid code also sets requirements on THD, which is the level of harmonic content allowed in the inverter's AC power output.
Product reliability	High inverter reliability ensures low downtime and maintenance and repair costs. If available, inverter mean time between failures (MTBF) figures and track record should be assessed.
Module supply	If modules of different specifications are to be used, then string or multi-string inverters are recommended, in order to minimise mismatch losses.
Maintainability and serviceability	Ease of access to qualified service and maintenance personnel, and availability of parts is an important dimension to consider during inverter selection. This may favour string inverters in certain locations.
System availability	If a fault arises with a string inverter, only a small proportion of the plant output is lost. Spare inverters could be kept locally and replaced by a suitably trained electrician. With central inverters, a large proportion of the plant output would be lost (for example, 100 kW) until a replacement is obtained.
Modularity	Ease of expanding the system capacity and flexibility of design should be considered when selecting inverters.
Shading conditions	For sites with different shading conditions or orientations, string inverters might be more suitable.
Installation location	Outdoor/indoor placement and site ambient conditions influence IP class and cooling requirements.
Monitoring/recording/telemetry	Plant monitoring, data logging, and remote control requirements define a set of criteria that must be taken into account when choosing an inverter.

7.1.2.1 Quality Benchmarks

The guarantee offered for inverters varies among manufacturers. A minimum guarantee of two years is typical, with optional extensions of up to twenty years or more. A 2009 survey of inverters^[35] showed that only one inverter manufacturer in the 100-500 kW range offers a guarantee longer than 20 years.

While many manufacturers quote MTBF of 20 years or more, real world experience shows that inverters generally need to be replaced every five to ten years. Based on a 2006 study^[36], investment in a new inverter is required three to five times over the life of a PV system.

Inverter protection should include:

- Incorrect polarity protection for the DC cable.
- Over-voltage and overload protection.
- Islanding detection for grid connected systems (depends on grid code requirements).
- Insulation monitoring.

Inverters should be accompanied by the appropriate type test certificates, which are defined by the national and international standards applicable for each project and country.

The inverter datasheet format and the information that should be included has been standardised and is covered by EN 50524:2009 – “Data sheet and name plate for photovoltaic inverters”. An example of the information expected in a datasheet is provided in Table 8.

[35] Photon International, *The Photovoltaic Magazine*, April 2009

[36] A Review of PV Inverter Technology Cost and Performance Projections, NREL Standards, Jan 2006

7.1.3 Mounting Structures

Mounting structures will typically be fabricated from steel or aluminium, although there are examples of systems based on wooden beams. A good quality mounting structure may be expected to:

- Have undergone extensive testing to ensure the designs meet or exceed the load conditions experienced at the site.
- Allow the desired tilt angle to be achieved within a few degrees.
- Allow field adjustments that may reduce installation time and compensate for inaccuracies in placement of foundations.
- Minimise tools and expertise required for installation.
- Adhere to the conditions described in the module manufacturer’s installation manual.
- Allow for thermal expansion, using expansion joints where necessary in long sections, so that modules do not become unduly stressed.

Purchasing good quality structures from reputable manufacturers is generally a low-cost, low-risk option. Some manufacturers provide soil testing and qualification in order to certify designs for a specific project location.

Alternatively, custom-designed structures may be used to solve specific engineering challenges or to reduce costs. If this route is chosen, it is important to consider the additional liabilities and cost for validating structural integrity. This apart, systems should be designed to ease installation. In general, installation efficiencies can be achieved by using commercially available products.

The topographic conditions of the site and information gathered during the geotechnical survey will influence the choice of foundation type. This, in turn, will affect the choice of support system design as some are more suited to a particular foundation type.

Table 8: Inverter Specification

Model	XXX	
Manufacturer	XXX	
Type (e.g. string, central, etc)	String	
DC	Maximum power	21.2 kW
	MPPT range	480...800 V
	Maximum voltage	1000 V
	Maximum current	41 A
AC	Rated power	19.2 kW
	Maximum power	19.2 kW
	Grid connection	3 AC 400 V + N, 50 – 60 Hz
	Maximum current	29 A
	Cos φ (DPF)	1 (± 0.9 on demand)
	THD	<2.5%
	Maximum efficiency	98.2%
	European efficiency	97.8%
	Internal consumption during night-time	<0.5 W
Transformer present	No	
Cooling	Natural convection	
Dimensions (WxHxD)	530 x 601 x 277 mm	
Weight	41 kg	
Working environment	-25...+55°C, up to 2000 m above sea level (ASL)	
IP rating	IP 65 as per EN 60259	
Warranty	3 years (basic); can be extended to 20 years	
Standards compliance	EN 61000-6-4:2007, EN 61000-6-2:2005, DIN IEC 721-3-3, VDE 0126-1-1	
Certificates	CE, UL, CSA	

Foundation options for ground-mounted PV systems include:

- **Concrete piers cast in-situ** – These are most suited to small systems and have good tolerance to uneven and sloping terrain. They do not have large economies of scale.
- **Pre-cast concrete ballasts** – This is a common choice for manufacturers having large economies of scale. It is suitable even at places where the ground is difficult to penetrate due to rocky outcrops or subsurface obstacles. This option has low tolerance to uneven or sloping terrain but requires no specialist skills for installation. Consideration must be given to the risk of soil movement or erosion.
- **Driven piles** – If a geotechnical survey proves suitable, a beam or pipe driven into the ground can result in low-cost, large scale installations that can be quickly implemented. Specialist skills and pile driving machinery are required, these may not always be available.
- **Earth screws** – Helical earth screws typically made of steel have good economics for large scale installations and are tolerant to uneven or sloping terrain. These require specialist skills and machinery to install.

7.1.3.1 Quality Benchmarks

The warranty supplied with support structures varies but may include a limited product warranty of 10 years and a limited finish warranty of five years or more. Warranties could include conditions that all parts are handled, installed, cleaned and maintained in the appropriate way, that the dimensioning is made according to the static loads and the environmental conditions are not unusual.

The useful life of fixed support structures, though dependent on adequate maintenance and corrosion protection, could be expected to be beyond 25 years.

In marine environments or within 3 km of the sea, additional corrosion protection or coatings on the structures may be required.

Tracker warranties vary between technologies and manufacturers but a 5-10 year guarantee on parts and workmanship may be typical.

Tracking system life expectancy depends on appropriate maintenance. Key components of the actuation system such as bearings and motors may need to be serviced or replaced within the planned project life.

Steel driven piles should be hot-dip galvanised to reduce corrosion. In highly corrosive soil, additional protection such as epoxy coating may be necessary in order to last the 25-35 year design life.

7.2 Layout and Shading

The general layout of the plant and the distance chosen between rows of mounting structures will be selected according to the specific site conditions. The area available to develop the plant may be constrained by space and may have unfavourable geological or topographical features. The aim of the layout design is to minimise cost while achieving the maximum possible revenue from the plant. In general this will mean:

1. Designing row spacing to reduce inter-row shading and associated shading losses.
2. Designing the layout to minimise cable runs and associated electrical losses.
3. Creating access routes and sufficient space between rows to allow movement for maintenance purposes.

4. Choosing a tilt angle that optimises the annual energy yield according to the latitude of the site and the annual distribution of solar resource.
5. Orientating the modules to face a direction that yields the maximum annual revenue from power production. In the northern hemisphere, this will usually be true south^[37].

Computer simulation software could be used to help design the plant layout. Such software includes algorithms which

describe the celestial motion of the sun throughout the year for any location on earth, plotting its altitude^[38] and azimuth^[39] angle on a sunpath diagram as shown in Figure 17. This, along with information on the module row spacing, may be used to

1. Calculate the degree of shading and
2. Simulate the annual energy losses associated with various configurations of tilt angle, orientation and row spacing.

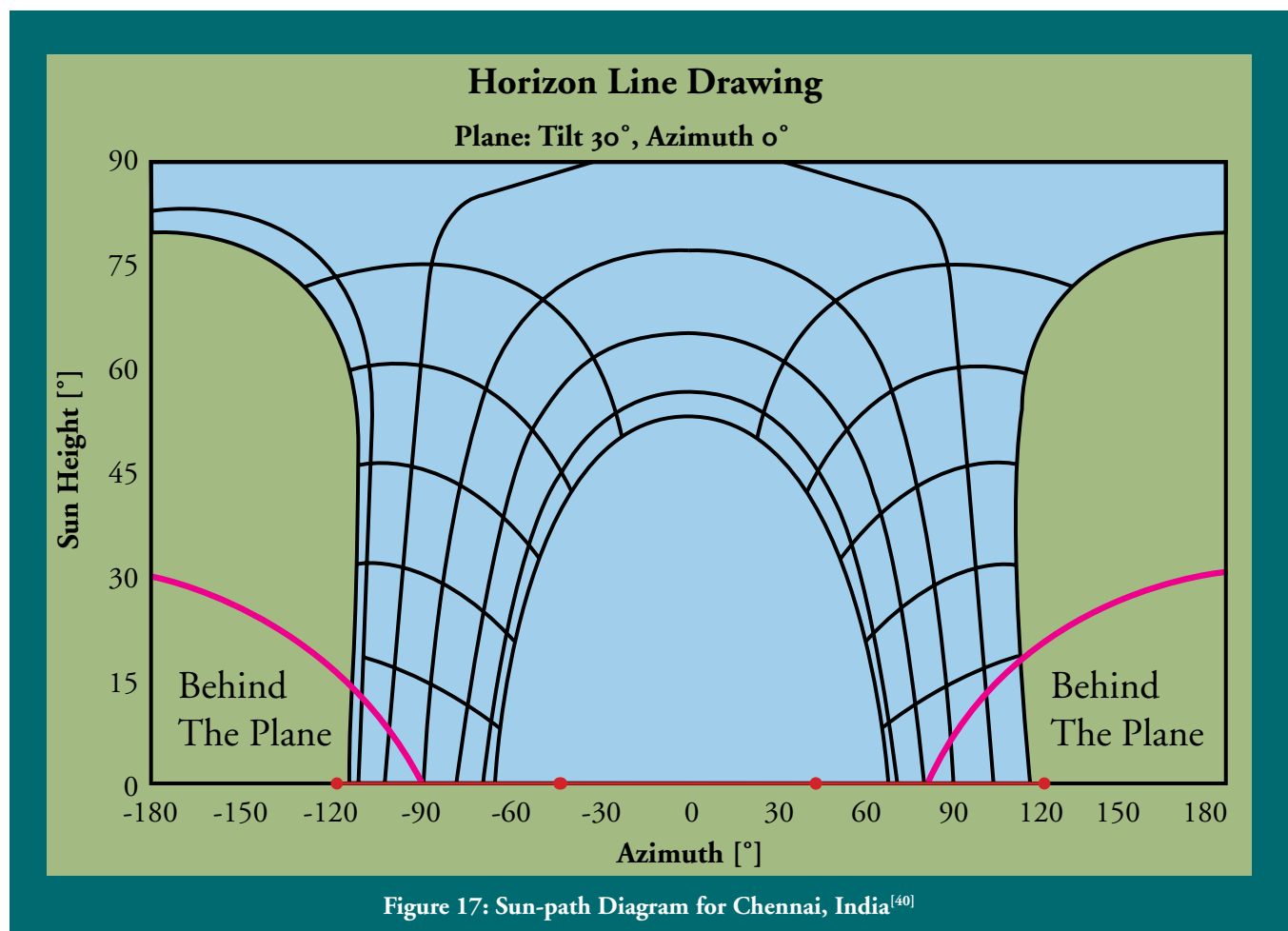

[37] True south differs from magnetic south, and an adjustment should be made from compass readings.

[38] The elevation of the sun above the horizon (the plane tangent to the Earth's surface at the point of measurement) is known as the angle of altitude.

[39] The azimuth is the location of the sun in terms of north, south, east and west. Definitions may vary but 0° represents true south, -90° represents east, 180° represents north, and 90° represents west.

[40] PVSYS V5.06

7.2.1 General Layout

Minimising cable runs and associated electrical losses may suggest positioning an LV/MV station centrally within the plant. If this option is chosen, then adequate space should be allocated to avoid the possibility of the station shading modules behind it.

The layout should allow adequate distance from the perimeter fence to prevent shading. It should also incorporate access routes for maintenance staff and vehicles at appropriate intervals.

7.2.2 Tilt Angle

Every location will have an optimal tilt angle that maximises the total annual irradiation (averaged over the whole year) on the plane of the collector. For fixed tilt grid connected power plants, the theoretical optimum tilt angle may be calculated from the latitude of the site. However, adjustments may need to be made to account for:

- **Soiling** – Higher tilt angles have lower soiling losses. The natural flow of rainwater cleans such modules more effectively and snow slides off more easily at higher angles.

- **Shading** – More highly tilted modules provide more shading on modules behind them. As shading impacts energy yield much more than may be expected simply by calculating the proportion of the module shaded, a good option (other than spacing the rows more widely apart) is to reduce the tilt angle. It is usually better to use a lesser tilt angle as a trade-off for loss in energy yield due to inter-row shading.
- **Seasonal irradiation distribution** – If a particular season dominates the annual distribution of solar resource (monsoon rains, for example), it may be beneficial to adjust the tilt angle to compensate for the loss. Simulation software is able to assess the benefit of this.

7.2.3 Inter-Row Spacing

The choice of row spacing is a compromise chosen to reduce inter-row shading while keeping the area of the PV plant within reasonable limits, reducing cable runs and keeping ohmic losses within acceptable limits. Inter-row shading can never be reduced to zero: at the beginning and end of the day the shadow lengths are extremely long. Figure 18 illustrates the angles that must be considered in the design process.

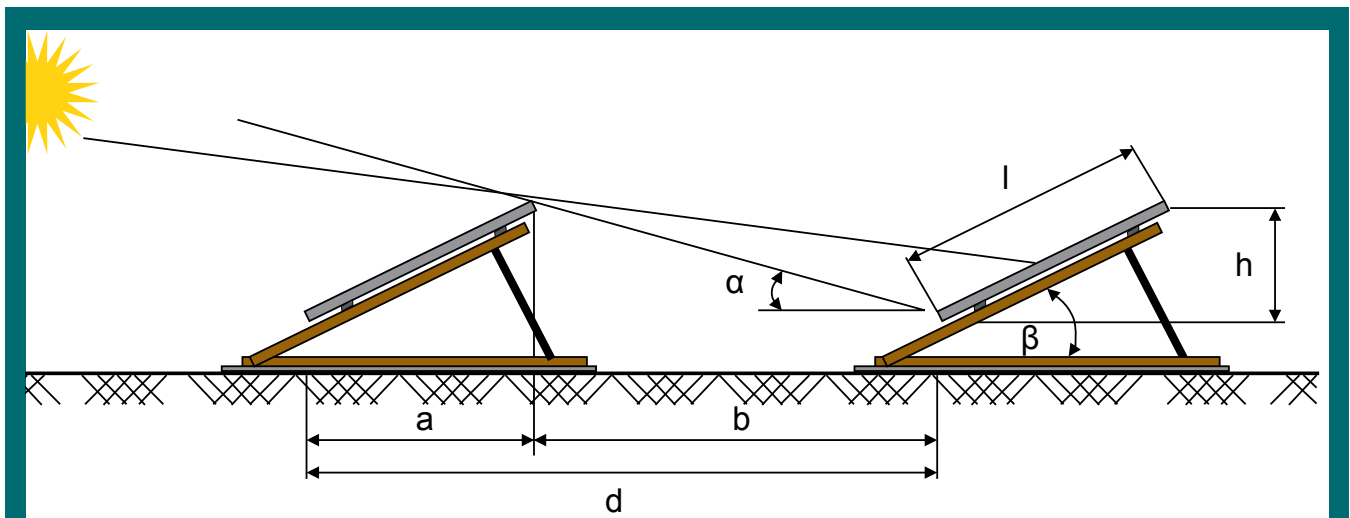

Figure 18: Shading Angle Diagram (Image courtesy of Schletter GmbH)

The shading limit angle^[41] α is the solar elevation angle beyond which there is no inter-row shading on the modules. If the elevation of the sun is lower than α then a proportion of the module will be shaded. Alongside, there will be an associated loss in energy yield.

The shading limit angle may be reduced either by reducing the tilt angle β or increasing the row pitch d . Reducing the tilt angle below the optimal is sometimes a choice as this may give only a minimal reduction in annual yield. The ground cover ratio (GCR), given by l/d , is a measure of the PV module area compared to the area of land required.

For many locations a design rule of thumb is to space the modules in such a way that there is no shading at solar noon on the winter solstice (December 21st in the northern hemisphere). In general, if there is less than a 1% annual loss due to shading, then the row spacing may be deemed acceptable.

Detailed energy yield simulations can be carried out to assess losses due to shading, and to obtain an economic optimisation that also takes into account the cost of land if required.

7.2.4 Orientation

In the northern hemisphere, the orientation that optimises the total annual energy yield is true south. In the tropics, the effect of deviating from true south may not be especially significant.

Some tariff structures encourage the production of energy during hours of peak demand. In such “time of day” rate structures, there may be financial (rather than energy yield) benefits of orientating an array that deviates significantly from

south. For example, an array facing in a westerly direction will be optimised to generate power in the afternoon. The effect of tilt angle and orientation on energy yield production can be effectively modelled using simulation software.

7.3 Electrical Design

For most large solar PV plants, reducing the levelised cost of electricity is the most important design criteria. Every aspect of the electrical system (and of the project as a whole) should be scrutinised and optimised. The potential economic gains from such an analysis are much larger than the cost of carrying it out.

It is important to strike a balance between cost savings and quality. Engineering decisions should be ‘careful’ and ‘informed’ decisions. Otherwise, design made with a view to reduce costs in the present could lead to increased future costs and lost revenue due to high maintenance requirements and low performance.

The design of each project should be judged on a case-by-case basis, as each site poses unique challenges and constraints. While general guidelines and best practices can be formulated, there are no “one-size-fits all” solutions. While the recommendations in the following sections are based on solar PV plants with centralised inverter architectures, many of the concepts discussed also apply to plants with string inverters.

The following sections are based mainly on European practices. Practices will differ elsewhere. It is, therefore, crucial to bear in mind that in all cases the relevant national and applicable international codes and regulations are consulted and followed, to ensure that the installation is safe and compliant.

[41] Also known as “critical shading angle”.

7.3.1 DC System

The DC system comprises the following plant:

- Array(s) of PV modules.
- DC cabling (module, string and main cable).
- DC connectors (plugs and sockets).
- Junction boxes/combiners.
- Disconnects/switches.
- Protection devices.
- Earthing.

When sizing the DC component of the plant, the maximum voltage and current of the individual strings and PV array(s) should be calculated using the maximum output of the individual modules. Simulation programs can be used to help with sizing but their results should be cross checked manually.

For mono-crystalline and multi-crystalline silicon modules, all DC components should be rated as follows, to allow for thermal and voltage limits^[42]:

$$\text{Minimum Voltage Rating: } V_{OC(STC)} \times 1.15$$

$$\text{Minimum Current Rating: } I_{SC(STC)} \times 1.25$$

The multiplication factors used above (1.15 and 1.25) are location-specific and cover the maximum voltage and current values that can be expected under UK conditions of irradiance. While different multiplication factors may apply for other locations, national standards should be consulted.

For non-crystalline silicon modules, DC component ratings should be calculated from manufacturer's data, taking into account the temperature and irradiance coefficients. In addition, certain modules have an initial settling-in period, during which the V_{OC} and I_{SC} output they produce is much

higher than that given by standard multiplication factors. So, this effect should also be taken into consideration. If in doubt, the manufacturer should be consulted for advice.

7.3.1.1 PV Array Design

The design of a PV array will depend on the inverter specifications and the chosen system architecture besides the specific context and conditions of use. Using many modules in series in high voltage arrays minimises ohmic losses. However, safety requirements, inverter voltage limits and national regulations also need to be considered.

- **Maximum number of modules in a string –** The maximum number of modules in a string is defined by the maximum DC input voltage of the inverter to which the string will be connected to ($V_{Max(Inv, DC)}$). Under no circumstances should this voltage be exceeded. Crossing the limit can decrease the inverter's operational lifetime or render the device inoperable. The highest module voltage that can occur in operation is the open-circuit voltage in the coldest daytime temperatures at the site location. Design rules of thumb for Europe use -10°C as the minimum design temperature, but this may vary according to location. The maximum number of modules in a string (n_{Max}) may therefore be calculated using the formula:

$$V_{OC(Module)@Coldest\ Module\ Operating\ Temperature} \times N_{Max} < V_{Max(Inv, DC)}$$

- **Minimum number of modules in a string –** The minimum number of modules is governed by the requirement to keep the system voltage within the MPPT range of the inverter. If the string voltage drops below the minimum MPP inverter voltage, then the system will underperform. In the worst case, the inverter may shut down. The lowest expected module voltage occurs during the highest operating temperature conditions. Design rules of thumb for Europe use 70°C as the design benchmark, but this may vary according to site conditions. The minimum number of modules in a string (n_{Min}) may therefore be calculated using the formula:

[42] Guide to the installation of PV systems – DTI (2006), 2nd edition.

$$V_{MPP(Module) @ Highest Module Operating Temperature} \times N_{Min} > V_{MPP(Inverter)}$$

- Voltage optimisation** – As the inverter efficiency is dependent on the operating voltage, it is preferable to optimise the design by matching the array

operating voltage and inverter optimum voltage as closely as possible. This will require voltage dependency graphs of inverter efficiency (see example in Figure 19). If such graphs are not provided by inverter manufacturers, they may be obtained from independent sources. Substantial increases

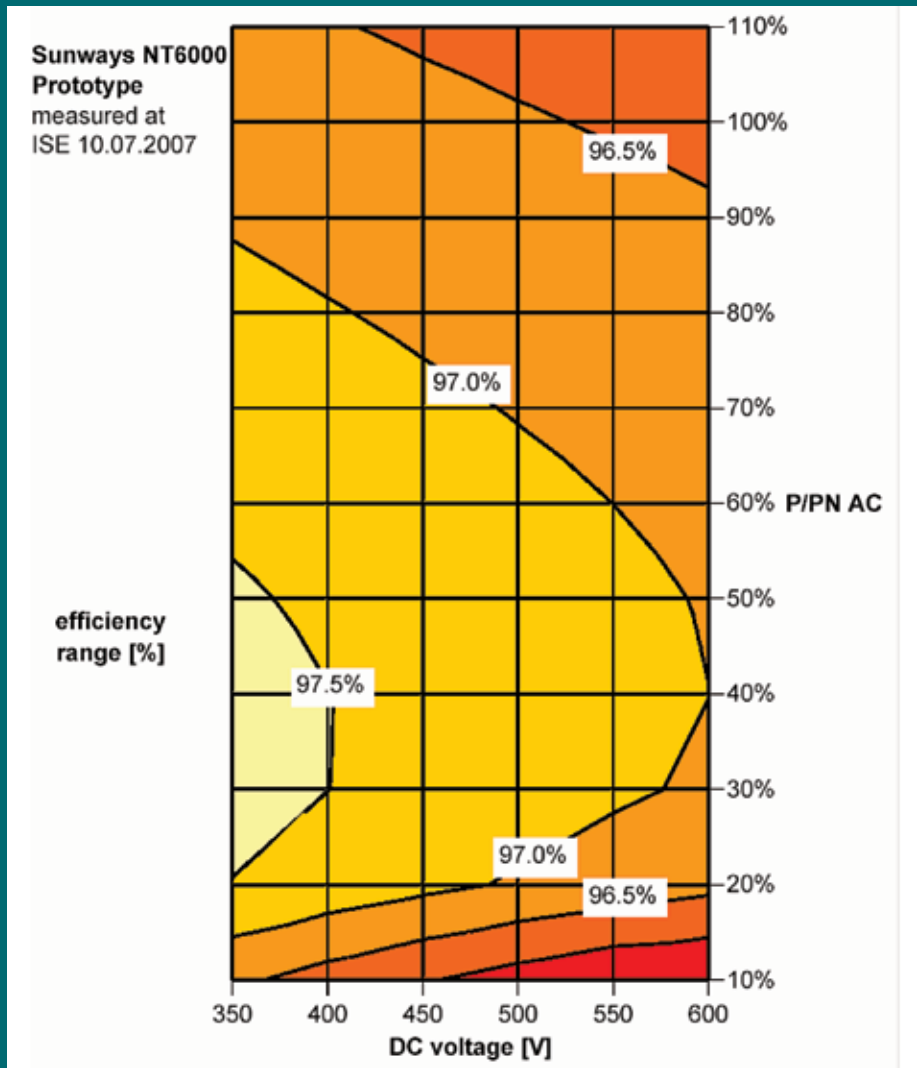

Figure 19: Voltage and Power Dependency Graph of Inverter Efficiency^[43]

[43] Image courtesy of F.P. Baumgartner, www.zhaw.ch/-bauf

in the plant yield can be achieved by successfully matching the operating voltages of the PV array with the inverter.

- **Number of strings** – The maximum number of strings permitted in a PV array is a function of the maximum allowable PV array current and the maximum inverter current. In general, this limit should not be exceeded as it leads to premature inverter ageing and yield loss.

7.3.1.2 Inverter Sizing

It is not possible to formulate an optimal inverter sizing strategy that applies in all cases. Project specifics such as the solar resource and module tilt angle play a very important role when choosing a design. While the rule of thumb has been to use an inverter-to-array power ratio less than unity, this is not always the best design approach. For example, this option might lead to a situation where the inverter manages to curtail power spikes not anticipated by irradiance profiles (based on one hour data). Or, it could fail to achieve grid code compliance in cases where reactive power injection to the grid is required.

The optimal sizing is, therefore, dependent on the specifics of the plant design. Most plants will have an inverter sizing range within the limits defined by:

$$0.8 < \text{Power Ratio} < 1.2$$

Where:

$$\text{Power Ratio} = \frac{P_{\text{Inverter DC rated}}}{P_{\text{PV Peak}}}$$

$$P_{\text{Inverter DC rated}} = \frac{P_{\text{inverter AC rated}}}{n_{100\%}}$$

Guidance on inverter and PV array sizing can be obtained from the inverter manufacturers, who offer system sizing software. Such tools also provide an indication of the total number of inverters required.

A number of factors and guidelines must be assessed when sizing an inverter:

- The maximum V_{OC} in the coldest daytime temperature must be less than the inverter maximum DC input voltage ($V_{Inv, DC Max}$).
- The inverter must be able to safely withstand the maximum array current.
- The minimum V_{OC} in the hottest daytime temperature must be greater than the inverter DC turn-off voltage ($V_{Inv, DC Turn-Off}$).
- The maximum inverter DC current must be greater than the PV array(s) current.
- The inverter MPP range must include PV array MPP points at different temperatures.
- When installed, some thin film modules produce a voltage greater than the nominal voltage. This happens for a period of time until initial degradation has occurred, and must be taken into account to prevent the inverter from being damaged.
- Grid code requirements: for example, reactive power injection.
- The operating voltage should be optimised for maximum inverter efficiency.
- Site conditions of temperature and irradiation profiles.
- Economics and cost-effectiveness.

Inverters with reactive power control are recommended. Inverters can control reactive power by controlling the phase angle of the current injection. Moreover, aspects such as inverter ventilation, air-conditioning, lighting and cabinet heating must be considered.

When optimising the voltage, it should be borne in mind that the inverter efficiency is dependent on voltage. Specification sheets and voltage dependency graphs are required for efficient voltage-matching.

7.3.1.3 Cable Selection and Sizing

The selection and sizing of DC cables for solar PV plants should take into account national codes and regulations applicable to each country. Cables specifically designed for solar PV installations (“solar” cables) are readily available and should be used. In general, three criteria must be observed when sizing cables:

1. **The cable voltage rating.** The voltage limits of the cable—to which the PV string or array cable will be connected—must be taken into account. Calculations of the maximum V_{OC} voltage of the modules, adjusted for the site minimum design temperature, are used for this calculation.
2. **The current carrying capacity of the cable.** The cable must be sized in accordance with the maximum current. It is important to remember to de-rate appropriately, taking into account the location of cable, the method of laying, number of cores and temperature. Care must be taken to size the cable for the worse case of reverse current in an array.

3. **The minimisation of cable losses.** The cable voltage drop and the associated power losses must be as low possible. Normally, the voltage drop must be less than 3%, but national regulations must be consulted for guidance. Cable losses of less than 1% are achievable.

In practice, the minimisation of voltage drop and associated losses will be the limiting factor in most cases.

7.3.1.4 Cable Management

DC cabling consists of module, string and main cables. Issues such as routing the main cables, and proper laying and trenching are to be considered in the detailed design of a solar PV plant. Additionally, management of overground cables (for example, module cables) also needs attention. Importantly, these cables need to be properly routed and secured to facilitate commissioning and troubleshooting. Proper management ensures that cables are properly protected from inclement weather and extraneous factors (for example, abrasion on the sharp edges of the support structures).

A number of cable connection systems are available:

- Screw terminals.
- Post terminals.
- Spring clamp terminals.
- Plug connectors.

Plug connectors have become the standard in grid connected solar PV plants, due to the benefits they offer in terms of installation ease and speed. These connectors are normally touch-proof (can be touched without risk of shock), and provide safety to module connections.

7.3.1.5 Module and String Cables

For module cables the following should apply^[44]:

$$\text{Minimum Voltage Rating} = V_{OC(STC)} \times 1.15$$

$$\text{Minimum Current Rating} = I_{SC(STC)} \times 1.25$$

The cables should be rated to the highest temperature they may experience (for instance, 80°C). Appropriate derating factors for temperature, installation method and cable configuration should also be applied.

Single conductor, double insulation cables are preferable for module connections. Using such cables helps protect against short-circuits. When sizing string cables, the number of modules and the number of strings per array need to be considered. The number of modules defines the voltage at which the cable should be rated. The number of strings is used to calculate the maximum reverse current that can flow through a string—especially, in case of a fault when there are no string fuses.

In an array comprising of N strings connected in parallel and M modules in each string, as shown in Figure 21, sizing of cables should be based on the following:

- Array with no string fuses (applies to arrays of three or fewer strings only)^[45].

$$\text{Voltage: } V_{OC(STC)} \times M \times 1.15$$

$$\text{Current: } I_{SC(STC)} \times (N - 1) \times 1.25$$

- Array with string fuses^[45].

$$\text{Voltage Rating} = V_{OC(STC)} \times M \times 1.15$$

$$\text{Current Rating} = I_{SC(STC)} \times 1.25$$

Usually, single conductor, halogen-free cables are preferred^[46]. If there is a high risk of lightning, cables should be screened. Again, opting for “solar” cables is advisable, as they are designed to meet the relevant requirements.

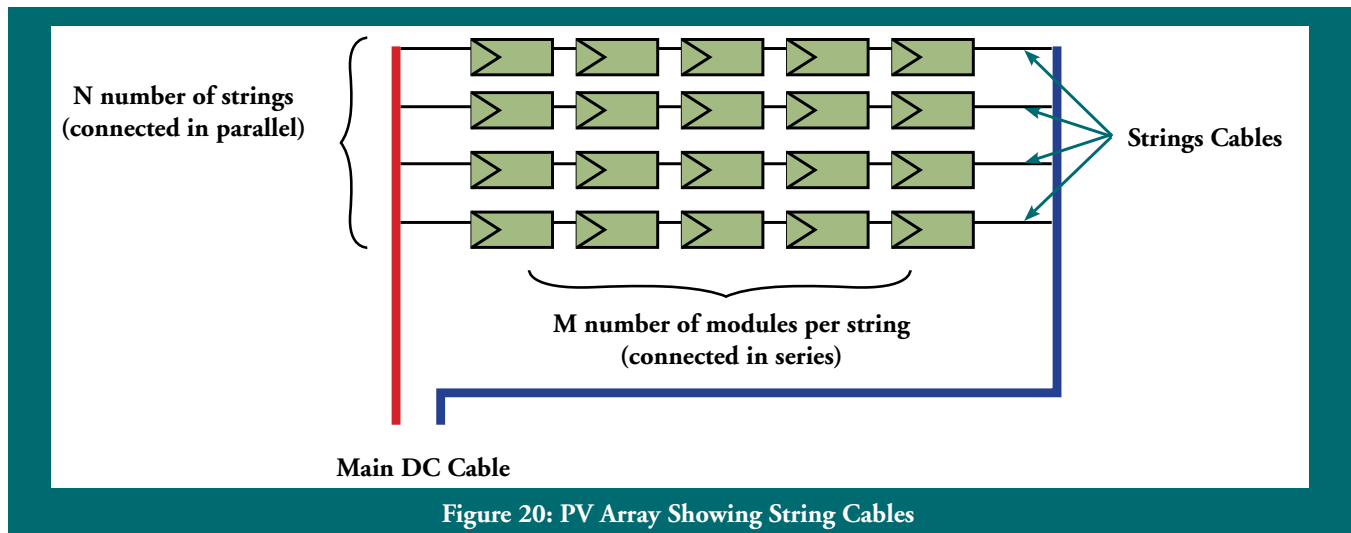

Figure 20: PV Array Showing String Cables

[44] Guide to the installation of PV systems – DTI (2006), 2nd edition. Assumes mono- and multi-crystalline silicon modules, and UK conditions for the multiplication factors.

[46] Halogen cables release corrosive and toxic gases if ignited.

7.3.1.6 Main DC Cable

The formulae that guide the sizing of main DC cables running from the PV array to the inverter, for a system as shown in Figure 20, are given below^[45]:

$$\text{Minimum Voltage Rating} = V_{OC(STC)} \times M \times 1.15$$

$$\text{Minimum Current Rating} = I_{SC(STC)} \times N \times 1.25$$

Standard de-rating factors must be also applied, as described in Section 7.3.1.3.

In order to reduce losses, the overall voltage drop between the PV array and the inverter (at STC) should be minimised. A benchmark voltage drop of less than 3% is suitable, and cables should be sized to reflect this benchmark. In most cases, over sizing cables to achieve lower losses is a worthwhile investment, since the allocated price for solar PV energy is usually much higher than the normal market price (due to

incentive schemes such as FiTs). The increased costs for higher cross section cables are thus amortised much faster.

7.3.1.7 Junction Boxes

Junction boxes or combiners are needed at the point where the individual strings forming an array are marshalled and connected together in parallel before leaving for the inverter through the main DC cable. Junctions are usually made with screw terminals and must be of high quality to ensure lower losses and to prevent overheating.

Junction boxes have protective and isolation equipment like string fuses and disconnects (also known as load break switches)^[47], and must be rated for outdoor placement using, for example, ingress protection (IP) 65. An explanation of the IP (International Protection Rating) bands is provided in Table 9. Depending on the solar PV plant architecture and size, multiple levels of junction boxes can be used.

Table 9: Definition of Ingress Protection (IP) Ratings			
Example: IP65 1st digit 6 (Dust tight) 2 nd digit 5 (Protected against water jets)			
1 st digit	Protection from solid objects	2 nd digit	Protection from moisture
0	Non-protected	0	Non-protected
1	Protection against solid objects greater than 50 mm	1	Protected against dripping water
2	Protection against solid objects greater than 12 mm	2	Protected against dripping water when tilted
3	Protection against solid objects greater than 2.5 mm	3	Protected against spraying water
4	Protection against solid objects greater than 1.0 mm	4	Protected against splashing water
5	Dust protected	5	Protected against water jets
6	Dust tight	6	Protected against heavy seas
		7	Protected against immersion
		8	Protected against submersion

[45] Assuming mono- and multi-crystalline silicon modules, and UK conditions for the multiplication factors. Relevant national standards should be consulted.

[47] Disconnects should be not confused with disconnectors/isolator that are dead circuit devices (or, devices that operate when there is no current flowing through the circuit).

It is important to remember that the DC side of a PV system cannot be switched off and that the terminals remain live during the day. Therefore clear and visible warning signs should be provided to inform anyone operating on the junction box. Furthermore, all junction boxes should be properly labelled as per national regulations for safety.

As a precaution, disconnects and string fuses should be provided. Disconnects permit the isolation of individual strings, while string fuses protect against faults, as discussed in Section 7.3.1.10. Disconnects should be capable of breaking normal load and should be segregated on both the positive and negative string cables.

To ensure protection against short-circuits, it is recommended that:

- The junction box enclosure is fabricated from non-conductive material.
- The positive and negative busbars are adequately separated and segregated.
- The enclosure layout should be such that short-circuits during installation and maintenance are extremely unlikely.

The system should be designed so that the main DC cable exiting the junction box can easily transition to a trench.

7.3.1.8 Connectors

Specialised plug and socket connections for PV applications have been developed, and are normally pre-installed to module cables to facilitate assembly. These plug connectors, which provide secure and touch-proof connections, are currently the preferred choice.

Connectors should be correctly rated and used for DC applications. As a rule, the connector current and voltage ratings should be at least equal to those of the circuit they are installed on.

Connectors should carry appropriate safety signs that warn against disconnection under load. Such an event can lead to arcing (producing a luminous discharge across a gap in an electrical circuit), and put personnel and equipment in danger. Any disconnection should take place only after the circuit has been properly isolated.

In order to avoid errors during installation, the design of DC connectors should be incompatible with AC connectors.

7.3.1.9 String Fuses

The main function of string fuses is to protect strings from over-currents. They must be designed for DC operation. Miniature fuses are normally used in PV applications. National codes and regulations must be consulted when selecting and sizing fuses.

The following guidelines apply to string fuses:

- All arrays formed of four or more strings should be equipped with fuses. Alternatively, fuses should be used where fault conditions could lead to significant reverse currents.
- In most cases, string fuses can be omitted in arrays with three or fewer series connected strings. However, the string cables must be rated to withstand the highest reverse currents expected. The system

designer must also consult the module manufacturer to ensure the module can withstand these reverse currents. Importantly, while it might not be necessary to fit fuses in systems consisting of two or three strings, it might still be beneficial to do so as this can facilitate testing and tracing of faults.

- Since faults can occur on both the positive and negative sides, fuses must be installed on all unearthed cables.
- To avoid nuisance tripping, the nominal current of the fuse should be at least 1.25 times greater than the nominal string current. Overheating of fuses can also cause nuisance tripping. For this reason, junction boxes should be kept in the shade.
- The string fuse must trip at less than twice the string short-circuit current at STC or at less than the string cable current carrying capability, whichever is the lower value.
- The trigger current of string fuses should be taken into account when sizing string cables. It should not be larger than the current at which the string cable is rated.
- The string fuse must be rated for operation at the string voltage using the formula^[48]:

$$\text{String Fuse Voltage Rating} = V_{OC(STC)} \times M \times 1.15$$

Miniature circuit breakers (MCBs) can also be used for over-current protection, but they are less common than fuses due to their higher cost.

Blocking diodes were commonly used in the past for circuit protection. However, string fuses are currently preferred as they serve the same function more efficiently.

7.3.1.10 DC Switching

DC switching is installed in the DC section of a solar PV plant to provide protection and isolation capabilities. DC switches/disconnects and DC circuit breakers are discussed below.

DC Switches/Disconnects – Judicious design practice calls for the installation of switching devices in PV array junction boxes. DC switches provide a means of manually electrically isolating entire PV arrays, which is required during installation and maintenance. DC switches must be:

- Double pole to isolate both the positive and negative PV array cables.
- Rated for DC operation.
- Capable of breaking under full load.
- Rated for the system voltage and maximum current expected.
- Equipped with proper safety signs.

DC Circuit Breaker – String fuses cannot be relied upon for disconnection of supply in case of fault conditions. This is due to the fact that PV modules are current-limiting devices, with a short-circuit current only a little higher than the nominal current. In other words, the fuse would not blow since the fault current would be less than the trigger current. For this reason, most PV codes and regulations recommend that main DC circuit breakers (CB) should be installed between the PV array fields and the grid connected inverters.

Certain inverter models are equipped with DC CBs. As such, installation of additional circuit breakers may become redundant. However, national regulations must be consulted to confirm the standards.

[48] Assuming mono- and multi-crystalline silicon modules, and UK conditions for the multiplication factors. Relevant national standards should be consulted.

7.3.1.11 Quality Benchmarks

Module cables must:

- Have a wide temperature range (-55 to 125°C).
- Be resistant to ultraviolet (UV) radiation and weather if laid outdoors without protection.
- Be single core and double insulated.
- Have mechanical resistance (animal proof, compression, tension and bending).

Apart from these, the risk of earth faults and short circuits should be minimised. Consequently, cable runs should be kept as short as possible. The following cable options are preferable because they offer increased protection:

- Single conductor cable – insulated and sheathed. For example, properly rated HO7RNF cables.
- Single conductor cable in suitable conduit/trunking.
- Multi core Steel Wire Armoured (SWA) – only suitable for main DC cables and normally used where an underground or exposed run is required.

7.3.2 AC System

7.3.2.1 AC Cabling

Cabling for AC systems should be designed to provide a safe, economic means of transmitting power from the inverters to the transformers and beyond. Cables should be rated for the operating voltage. They should also have conductors and screens sized for operating currents and short circuit currents.

It is important that the cable chosen is specified correctly. The following should be considered when designing the cabling:

- The cable must be rated for the maximum expected voltage.
- The conductor should be able to pass the operating and short circuit currents safely.
- The conductor should be sized appropriately to ensure that losses produced by the cable are within acceptable limits, and that the most economic balance is maintained between capital cost and operational cost (losses).
- The conductors should be sized to avoid voltage drop outside statutory limits and equipment performance.
- Insulation should be adequate for the environment of installation.
- Either copper or aluminium conductors should be chosen.

- A suitable number of cores should be chosen (either single or multi-core).
- Earthing and bonding should be suitably designed for the project application.
- The installation method and mechanical protection of the cable should be suitably designed for the project.

Cables should comply with relevant IEC standards or national standards. Examples of these include:

- IEC 60502 for cables between 1 kV and 36 kV.
- IEC 60364 for LV cabling (BS 7671 in UK).
- IEC 60840 for cables rated for voltages above 30 kV and up to 150 kV.

7.3.2.2 AC Switchgear

Appropriately rated switchgear and protection systems should be provided throughout the electrical system to provide disconnection, isolation, earthing and protection for the various components of the plant. On the output side of the inverters, provision of a switch disconnecter is recommended as a means to isolate the PV array. Other switchgear may be required, depending on the size and set up of the electrical infrastructure in the solar plant.

Switchgear type will largely be dependent on the voltage of operation. Switchgear up to 33 kV is likely to be an internal metal clad cubicle type. Also, it will have gas – or air-insulated busbars, and vacuum or SF6 breakers. For higher voltages, the preferred choice will most likely be air-insulated outdoor switchgear or, if space is an issue, gas-insulated indoor switchgear.

All switchgear should:

- Be in accordance with relevant IEC and national standards.
- Have the option to be secured by locks in off/earth positions.
- Clearly show the ON and OFF positions with appropriate labels.
- Be rated for operational and short circuit currents.
- Be rated for the correct operational voltage.
- In the case of HV switchgear, have remote switching capability.
- Be provided with suitable earthing.

It should be noted that HV switching is a hazardous procedure, and safety measures to minimise risk should be adopted as good practice.

7.3.2.3 Sizing and Selecting Transformers

The purpose of transformers in a solar power plant is to provide suitable voltage levels for transmission across the site and for export to the grid. In general, the inverters supply power at LV. But for a commercial solar power plant, grid connection is typically made at upwards of 11 kV (HV levels).

It is therefore necessary to step up the voltage using a transformer between the inverter and the grid connection point. Figure 21 shows a high level single line diagram showing typical voltages of operation for the AC system of a solar power plant.

Selection and specification – The selection of an appropriate transformer should consider several basic issues. These include the required size of the transformer, its position within the electrical system, and the physical location of installation. The size of the transformer, which will depend on the projected maximum power exported from the solar array, should be specified in MVA.

Power would generally be expected to flow from the solar arrays to the grid. To prepare for the reverse case (a need to supply power back to the plant), this should be specified or an auxiliary transformer used. The position of the transformer in the electrical system will define the required voltage levels on the primary and secondary sides of the transformer. Tertiary supplies for substation auxiliary services and/or harmonic mitigation should also be considered.

In addition, the physical location and the anticipated environmental conditions will need to be specified. International and national standards should be specified as required. The requirements for power transformers are defined in IEC 60076.

Other issues to consider when designing and specifying a transformer may also include:

- Tap setting requirements.
- Cooling medium.
- Earthing.
- Winding connections.
- Number of windings.
- Requirement for redundancy/spare transformer.
- Losses.
- Bushings for connection of cabling and overhead lines.
- Transformer trip and warning alarms.

Choosing a reputable manufacturer to carry out the detailed design and manufacture should ensure that the transformer provided is of the required standard. There are, of course, many other parameters and design considerations that could be specified.

Losses – Transformers can lose energy through magnetising current in the core, known as iron losses and copper losses in the windings. Minimising the losses in a transformer is a key requirement as this will increase the energy supplied to the grid and, as a result, enhance the revenue of a solar power plant.

Test Requirements – Transformers should be subject to a number of routine and type tests performed on each model manufactured; these tests are set out in IEC 60076. The manufacturer also can be requested to undertake special tests mentioned in IEC 60076.

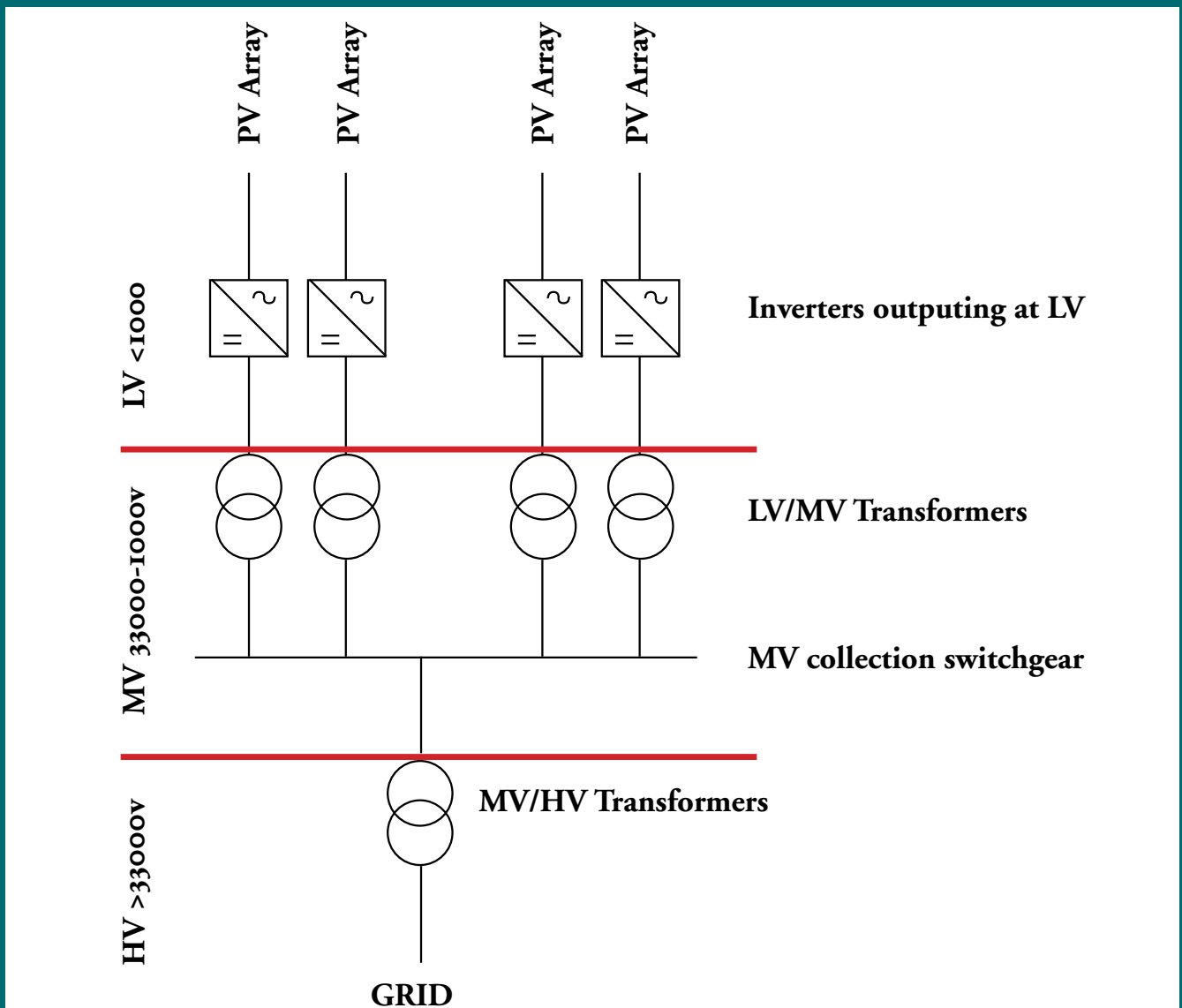

Figure 21: Typical Transformer Locations and Voltage Levels in a Solar Plant where Export to Grid is at HV

Delivery and Commission – Consideration should be given to the period of time required for manufacture and delivery of transformers. Most large transformers will be designed and built on order, and will therefore have a lengthy lead time, which can stretch to several years.

The delivery of large transformers to the site can also be a problem. Large transformers can be broken down to some extent, but the tank containing the core and winding will always need to be moved in one piece. In the case of transformers around the 100 MVA size, the burden of

transportation will still be significant and road delivery may require special measures such as police escort.

The positioning of the transformer in the power plant should also be decided at the planning stage. By doing this, a transformer can be easily and safely installed, maintained and—in the event of a failure—replaced. Liquid-filled transformers should be provided with a bund to catch any leakage. Oil-filled transformers, if sited indoors, are generally considered a special fire risk. As such, measures to reduce the risk to property and life should be considered.

7.3.2.4 Substation

The substation houses the primary and secondary electrical equipment for the central operation of the solar plant and connection to the local electricity grid. The substation can also provide an operational base for staff required for operation and maintenance as well as stores or other auxiliary functions associated with the solar plant. Equipment such as the LV/MV transformers, MV switchgear, SCADA (Supervisory Control and Data Acquisition) systems, protection and metering systems can be placed within the substation.

The layout of the substation should optimise the use of space while still complying with all relevant building codes and standards. A safe working space should be provided around the plant for the operation and maintenance staff.

The substation may be wholly internal or may consist of internal and external components such as transformers, HV switchgear and backup generators. Separation between MV switch rooms, converter rooms, control rooms, store rooms and offices is a key requirement, besides providing safe access, lighting and welfare facilities. In plants where the substation is to be manned, care should be taken to provide facilities like a canteen and washrooms.

Where HV systems are present, an earth mat may need to be provided to obtain safe step/touch potentials and earth system faults. Earth mats should be installed prior to setting the foundation. Lightning protection should be considered to alleviate the effect of lightning strikes on equipment and buildings.

A trench is often required as a means for easing the routing of power and data cables to the substation.

Where necessary, the substation may also need to accommodate the grid company's equipment (which might be in a separate area of the building). Additional equipment may include:

Metering – Tariff metering will be required to measure the export of power. This may be provided at the substation or at the point of connection to the grid. Current transformers and voltage transformers provided in the switchgear will be connected to metering points by screened cable.

Data Monitoring/SCADA – SCADA systems provide control and status indication for the items included in the substation and across the solar plant. The key equipment may be situated in the substation in control and protection rooms. Air conditioning should be considered due to the heat generated by the electronic equipment in the modules.

Auxiliary equipment – The design of the substation should take into account the need for auxiliary systems required for a functioning substation/control room. All auxiliary equipment should be designed to relevant standards and may include:

- LV power supplies.
- Back-up power supplies.
- Uninterruptible power supply (UPS) batteries.
- Diesel generators.
- Auxiliary transformers and grid connections.
- Telephone and internet connections.
- Lighting.
- Heating Ventilation and Air Conditioning (HVAC).
- Water supplies.
- Drainage.
- Fire and intruder alarms.

7.3.2.5 Earthing and Surge Protection

The earthing of a solar PV plant influences a number of risk parameters, namely:

- The electric shock risk to people on site.
- The risk of fire during a fault.
- The transmission of surges induced by lightning.
- The severity of EMI.

The earthing of a solar PV plant encompasses the following:

- Array frame earthing.
- System earthing (DC conductor earthing).
- Inverter earthing.
- Lightning and surge protection.

Earthing should be provided as a means to protect against electric shock, fire hazard and lightning. By connecting to the earth, charge accumulation in the system during an electrical storm is prevented.

The entire PV plant and the electrical room should be protected from lightning. Protection systems are usually based on early streamer emission, lightning conductor air terminals. The air terminal will be capable of handling multiple strikes of lightning current and should be maintenance-free after installation.

These air terminals will be connected to respective earthing stations. Subsequently an earthing grid will be formed, connecting all the earthing stations through the required galvanised iron tapes.

The earthing arrangements on each site will vary, depending on a number of factors:

- National electricity requirements.
- Installation guidelines for module manufacturers.
- Mounting system requirements.
- Inverter requirements.
- Lightning risk.

While the system designer must decide the most appropriate earthing arrangement for the solar PV plant, one can follow the general guidelines given below:

- Ground rods should be placed close to junction boxes. Ground electrodes should be connected between the ground rod and the ground lug in the junction box.
- A continuous earth path is to be maintained throughout the PV array.
- Cable runs should be kept as short as possible.
- Surge suppression devices can be installed at the inverter end of the DC cable and at the array junction boxes.
- Both sides of an inverter should be properly isolated before carrying out any work, and appropriate safety signs should be installed as a reminder.
- Many inverter models include internal surge arrestors. Besides, separate additional surge protection devices may be required. Importantly, national codes and regulations, and the specific characteristics of each project must be taken into account.

7.3.2.6 Quality Benchmarks

The AC cable should be supplied by a reputable manufacturer accredited to ISO 9001. The cable should have:

- Certification to current IEC and national standards such as IEC 60502 for cables between 1 kV and 36 kV, IEC 60364 for LV cabling and IEC 60840 for cables rated for voltages above 30 kV and up to 150 kV.
- Type testing completed to appropriate standards.
- A minimum warranty period of two years.
- A design life equivalent to the design life of the project.
- Ultraviolet (UV) radiation and weather resistance (if laid outdoors without protection).
- Mechanical resistance (for example, compression, tension, bending and resistance to animals).

AC switchgear should be supplied by a reputable manufacturer accredited to ISO 9001 and should have:

- Certification to current IEC and appropriate national standards such as IEC 62271 for HV switchgear and IEC 61439 for LV switchgear.
- Type testing to appropriate standards.
- A minimum warranty period of two years.
- An expected lifetime at least equivalent to the design life of the project.

Transformers should be supplied by reputable manufacturers accredited to ISO 9001. They should have:

- Certification to IEC and appropriate national standards such as IEC 60076 for the power transformer, IEC 60085 for electrical insulation and IEC 60214 for tap changers.

- Type testing to appropriate standards.
- A minimum warranty period of two years.
- An expected lifetime at least equivalent to the design life of the project.
- The efficiency should be at least 96%.

An example of the information expected in datasheets is provided in Appendix B – AC Benchmarks.

7.4 Infrastructure

A utility scale PV power plant requires infrastructure appropriate to the specifics of the design chosen. Locations should be selected in places where buildings will not cast unnecessary shading on the PV module. It may be possible to locate buildings on the northern edge of the plant to reduce shading, or to locate them centrally if appropriate buffer zones are allowed for. Depending on the size of the plant, infrastructure requirements may include:

- **Office** – A portable office and sanitary room with communication devices. This must be watertight and prevent entry to insects. It should be located to allow easy vehicular access.
- **LV/MV station** – Inverters may either be placed amongst the module support structures (if string inverters are chosen) in specially designed cabinets or in an inverter house along with the medium voltage transformers, switchgear and metering system^[49]. This “LV/MV station” may be equipped with an air conditioning system if it is required to keep the electrical devices within their design temperature envelopes.
- **MV/HV station** – An MV/HV station may be used to collect the AC power from the medium voltage transformers and interface to the power grid.

[49] For string inverters, the LV/MV station may be used to collect the AC power.

- **Communications** – The plant monitoring system and the security system will require a communications medium with remote access for visibility and control of the plant. There can also be a requirement from the grid network operator for specific telephone landlines for the grid connection. Often, an Internet broadband (DSL) or satellite communications system is used for remote access. A GSM (Global System for Mobile Communications) connection or standard telephone line with modems is an alternative though it has a lower data transfer rate.

7.4.1 Quality Benchmarks

Some benchmark features of PV plant infrastructure include:

- Water-tight reinforced concrete stations or pre-fabricated steel containers.
- Sufficient space to house the equipment and facilitate its operation and maintenance.
- Inclusion of:
 - Ventilation grilles, secure doors and concrete foundations that allow cable access.
 - Interior lighting and electrical sockets.
 - Either adequate forced ventilation or air-conditioning with control thermostats, depending on environmental conditions.

7.5 Site Security

PV power plants represent a large financial investment. The modules are not only valuable but also portable. Efforts should be made to reduce the risk of theft and tampering. Such efforts may include:

- Reducing the visibility of the power plant by planting shrubs or trees at appropriate locations. Care should be taken that these do not shade the plant.
- Installing a wire mesh fence with anti-climb protection. A fence is also recommended for safety reasons and may be part of the grid code requirements for public safety. Measures should be taken to allow small animals to pass underneath the fence at regular intervals.
- Security cameras, lights and microwave sensors with GSM and TCP/IP transmission of alarms and faults to a security company as an option.
- Anti-theft module mounting bolts may be used and synthetic resin can be applied once tightened. The bolts can then only be released after heating the resin up to 300°C.
- Anti-theft module fibre systems may be used. These systems work by looping a plastic fibre through all the modules in a string. If a module is removed, the plastic fibre is broken. This triggers an alarm.
- A permanent guarding station with security guard providing the level of security required in the insurance policy.
- An alarm system fitted to the power plant gate and the medium voltage station, metering station and to any portable cabins.

7.5.1 Quality Benchmarks

Some benchmark security features include:

- Fence at least two meters high.
- Metallic posts installed every 6m.
- Galvanised and plastic coated fencing.
- Video surveillance:
 - Multiple night and day cameras at a set distance apart.
 - Illumination systems (infrared) for cameras along the perimeter of the site.
 - A minimum of 12 months recording time.

7.6 Monitoring and Forecasting

7.6.1 Monitoring Technology

If high performance, low downtime and rapid fault detection is required, automatic data acquisition and monitoring technology is essential. This allows the yield of the plant to be monitored and compared with calculations made from solar irradiation data. Monitoring and comparison also help raise warnings on a daily basis if there is a shortfall. Faults can be detected and rectified before they have an appreciable effect on production.

Relying solely on manual checks of performance is not advisable. A high level of technical expertise is needed to detect certain partial faults at the string level. In fact, it can take many months for reduced yield figures to be identified. The lower yield may lead to appreciable revenue loss for a utility scale PV power plant.

The key to a reliable monitoring and fault detection methodology is to have good knowledge of the solar irradiance, environmental conditions and plant power output simultaneously. This allows faults to be distinguished from, for example, passing clouds or low resource days. There are

three main methods for obtaining the solar irradiance and environmental conditions:

- **On-site weather stations** – To measure the plane of array irradiance, module temperature and preferably horizontal global irradiance, humidity and wind speed. This is the option of preference for many current utility scale PV power plants. It allows data to be collected and compared remotely with yield figures on a daily basis for immediate fault detection.
- **Meteorological data gathered from weather satellites** – Simulation and calculation algorithms measure the projected power plant output. This figure becomes the benchmark for comparing values received from the PV plant on a daily basis, and helps detect faults immediately. This method removes the need for an onsite weather station. A number of good commercial providers of packages use this technique in Europe. Rapid fault detection depends on data being made available from satellites and being analysed quickly.
- **Local weather stations** – This is the least desirable of the three options as data may not be available for several months. During that period, the plant may lose considerable revenue if faults in the plant go undetected. It is also possible that the local weather station does not accurately track the conditions at the site (especially if it is some kilometres distant).

In case there are other PV power plants in the vicinity of the site—or one large plant is split into a number of components—it is possible to compare production data and identify a fault with one plant. Internet-based solutions are available that function in this manner.

The on-site weather station solution is currently the most common option. Data-loggers can be used to collect data from the weather station, inverters, meters and transformers. This information is transferred once a day to a server which carries out three key functions:

- **Operations management** – The performance management (either onsite or remote) of the PV power plant enables the tracking of inverters or strings.
- **Alarm management** – Flagging any element of the power plant that falls outside pre-determined performance bands. Failure or error messages can be automatically generated and sent to the power plant

service team via fax, email or text message.

- **Reporting** – The generation of yield reports detailing individual component performance, and benchmarking the reports against those of other components or locations.

Figure 22 illustrates the architecture of an internet portal based monitoring system.

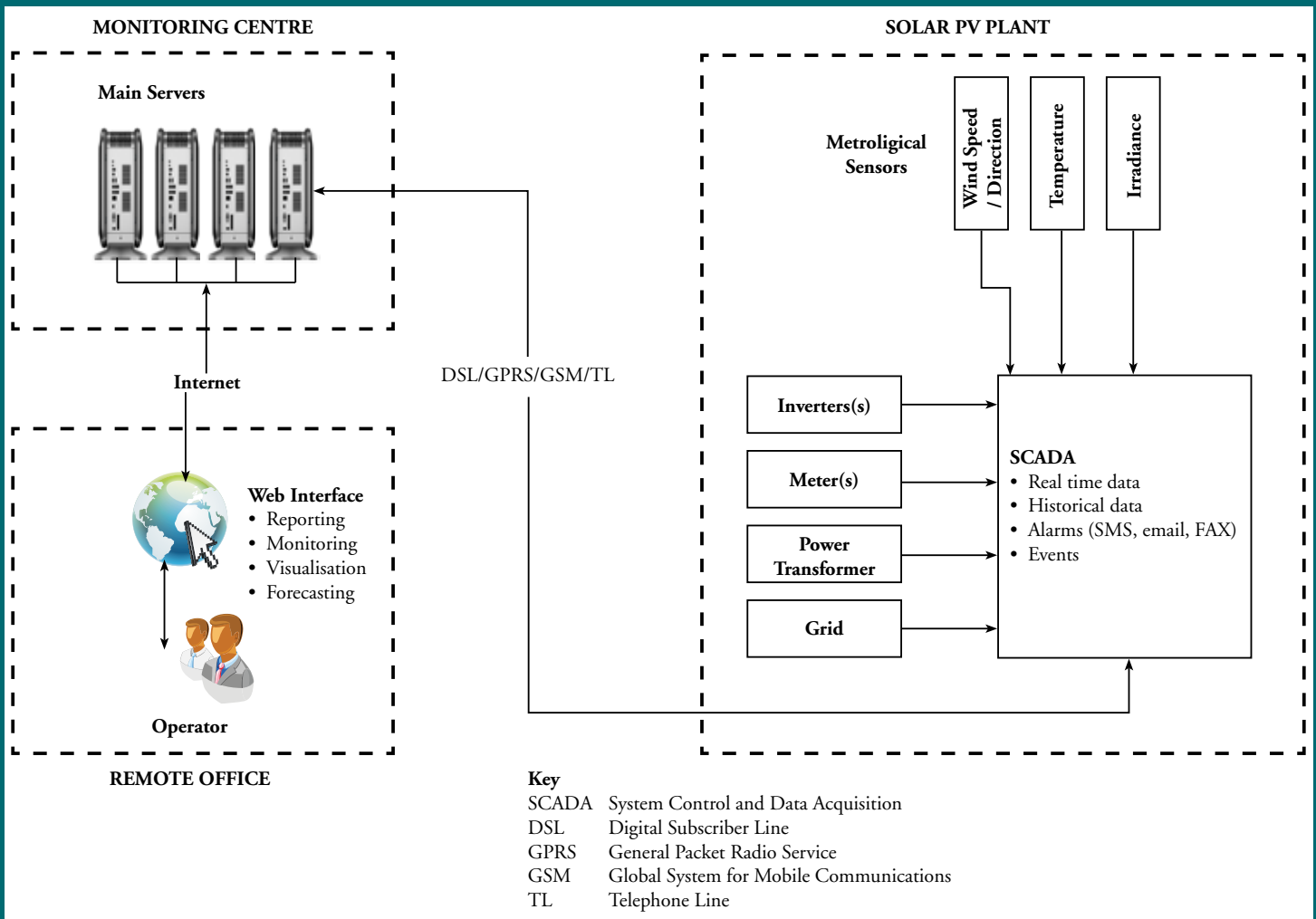

Figure 22: PV System Monitoring Schematic

7.6.2 Forecasting Technology

Dispatchable power plants typically need to provide a forecast to the network operator. This helps to fix plant schedules and guarantee continuity of supply. Often, production forecasts (in half hourly time-steps) are required 24 hours in advance. This entails weather forecasts coupled with power forecasting algorithms—more so since PV power production is intermittent and random in nature. Such forecasting algorithms can use physical models, statistical approaches or a combination of both. At the least, the algorithms require the definition of:

- Power plant capacity.
- Module tilt and orientation.
- Module specifications.
- Latitude and longitude of the plant.
- Meteorological agency data, gathered from ground measurement stations and/or satellites.

The algorithms typically take three-hour national and/or regional forecasts and break them down to 30 minute local forecasts (temporal interpolation) before using algorithms to forecast power production. Comparison of historical production and actual weather can also allow learning algorithms to be employed. Figure 23 shows the components of a forecasting system. Results of forecasting are typically posted on web portals. There are a variety of commercial forecasting products available in the market today. But availability may be limited to regions that have rapid access to meteorological agency's weather data.

7.6.3 Quality Benchmarks

Monitoring systems should be based on commercially available software/hardware which is supplied with user manuals and appropriate technical support.

Depending on the size and type of the plant, minimum parameters to be measured include:

- Plane of array irradiance measured to accuracy within 5% and stability within 0.5% per year. The irradiation sensor will be of the same technology as the modules being measured, or technology independent. Silicon sensor reference cells are not advisable for use in Performance Ratio calculations.
- Ambient temperature measured in a location representative of site conditions with accuracy better than $\pm 1^{\circ}\text{C}$.
- Module temperature measured with accuracy better than $\pm 1^{\circ}\text{C}$. This is done using a sensor thermally bonded to the back of the module in a location positioned at the centre of a cell.
- Array DC voltage measured to an accuracy of within 1%.
- Array DC current measured to an accuracy of within 1%.
- Inverter AC power measured as close as possible to the inverter output terminals with an accuracy of within 1%.
- Power to the utility grid.
- Power from the utility grid.
- Measurement of key parameters at one-minute intervals.

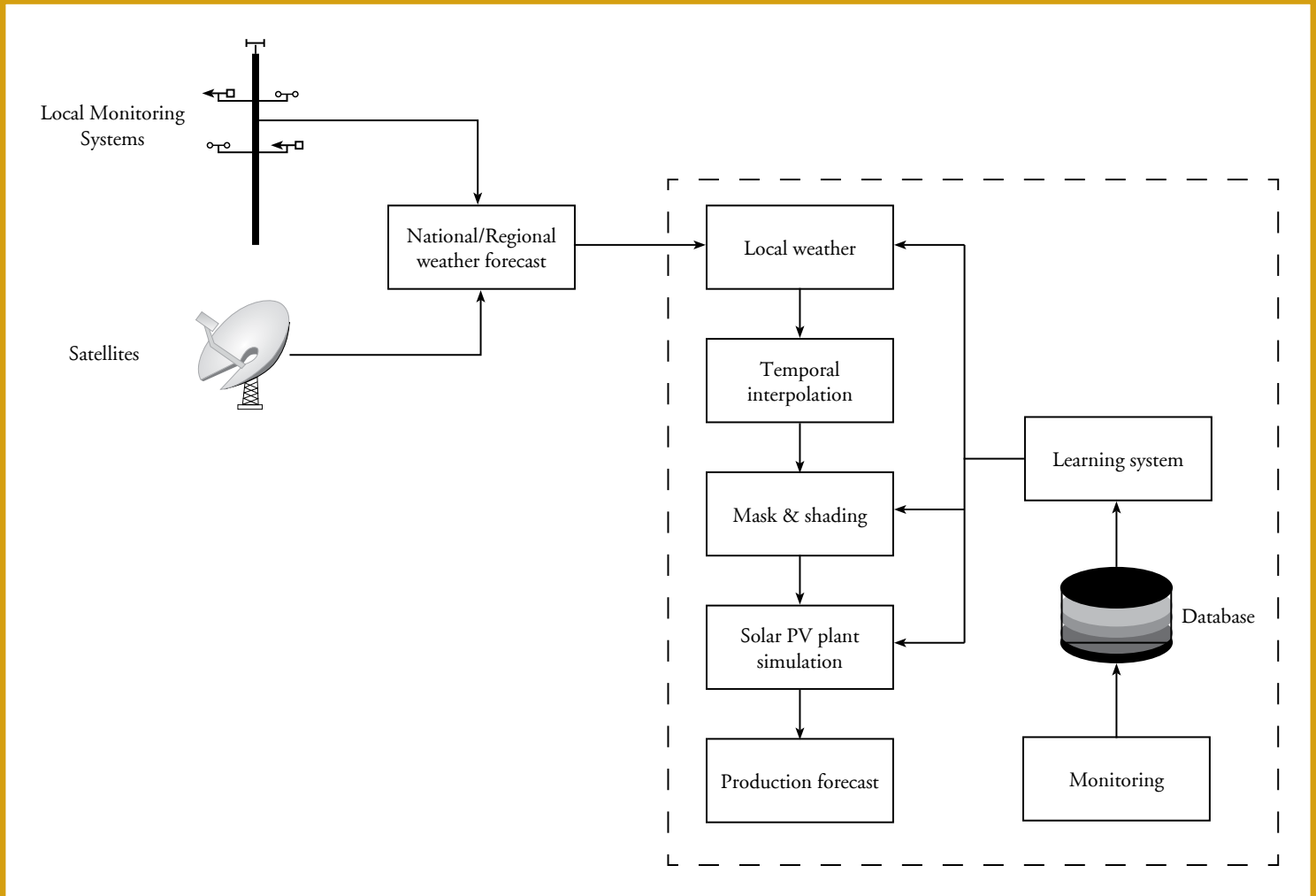

Figure 23: Components of a Forecasting System

7.7 Optimising System Design

The performance of a PV power plant may be optimised by a combination of several enabling factors: premium quality modules and inverters; a good system design with high quality and correctly installed components; and a good preventative maintenance and monitoring regime leading to low operational faults.

The aim is to minimise losses. Measures to achieve this are described in Table 10. Reducing the total loss increases the annual energy yield and hence the revenue, though in some cases it may increase the cost of the plant. Interestingly, efforts to reduce one type of loss may be antagonistic to efforts to reduce losses of a different type. It is the skill of the plant

Table 10: Performance Optimisation Strategies

Loss	Mitigating Measure to Optimise Performance
Shading	<ul style="list-style-type: none"> Choose a location without shading obstacles. Ensure that the plant has sufficient space to reduce shading between modules. Have a robust O&M strategy that removes the risk of shading due to vegetation growth.
Incident angle	<ul style="list-style-type: none"> Use anti-reflection coatings, textured glass, or tracking.
Low irradiance	<ul style="list-style-type: none"> Use modules with good performance at low light levels.
Module temperature	<ul style="list-style-type: none"> Choose modules with a lower negative temperature coefficient for power at high ambient temperature locations.
Soiling	<ul style="list-style-type: none"> Choose modules less sensitive to shading (for example amorphous silicon). Ensure a suitable O&M contract that includes an appropriate cleaning regime for the site conditions.
Module quality	<ul style="list-style-type: none"> Choose modules with a low tolerance. A tolerance of $\pm 3\%$ is typical but tolerances of between $\pm 1.5\%$ to $\pm 10\%$ are common.
Module mismatch	<ul style="list-style-type: none"> Sort modules with similar characteristics into series strings where possible. Avoid partial shading of a string. Avoid variations in module tilt angle.

designer to make suitable compromises that result in a plant with a high performance at a reasonable cost.

The ultimate aim of the designer is to create a plant that maximises financial returns. In other words, it will usually mean minimising the levelised cost of electricity.

Table 10: Performance Optimisation Strategies

Loss	Mitigating Measure to Optimise Performance
DC wiring resistance	<ul style="list-style-type: none"> • Use appropriately dimensioned cable. • Reduce the length of DC cabling.
Inverter performance	<ul style="list-style-type: none"> • Choose correctly sized, highly efficient inverters.
AC losses	<ul style="list-style-type: none"> • Use correctly dimensioned cable. • Reduce the length of AC cabling. • Use high efficiency transformers.
Downtime	<ul style="list-style-type: none"> • Use a robust monitoring system that can identify faults quickly. • Choose an O&M contractor with good repair response time. • Keep spares holdings.
Grid availability	<ul style="list-style-type: none"> • Install PV plant capacity in areas where the grid is strong and has the potential to absorb PV power.
Degradation	<ul style="list-style-type: none"> • Choose modules with a low degradation rate and a peak power guarantee.
MPP tracking	<ul style="list-style-type: none"> • Choose high efficiency inverters with good maximum power point tracking algorithm. • Avoid module mismatch.
Curtailement of tracking	<ul style="list-style-type: none"> • Ensure that tracking systems are suitable for the wind loads to which they will be subjected.

7.8 Design Documentation Requirements

There are a number of minimum requirements that should be included within design documentation. These include:

- Datasheets of modules, inverters, array mounting system and other system components.
- Wiring diagrams including, as a minimum, the information laid out in Table 11.
- Layout drawings showing the row spacing and location of site infrastructure.
- Mounting structure drawings with structural calculations reviewed and certified by a licensed engineer.
- A detailed resource assessment and energy yield prediction.
- A design report. It will include information on the site location, site characteristics, solar resource, a summary of the results of the geotechnical survey, design work and the energy yield prediction.

Table 11: Annotated Wiring Diagram Requirements

Section	Required details
Array	<ul style="list-style-type: none"> • Module type(s) • Total number of modules • Number of strings • Modules per string
PV String Information	<ul style="list-style-type: none"> • String cable specifications – size and type. • String over-current protective device specifications (where fitted) – type and voltage/current ratings. • Blocking diode type (if relevant).
Array electrical details	<ul style="list-style-type: none"> • Array main cable specifications – size and type. • Array junction box locations (where applicable). • DC isolator type, location and rating (voltage/current). • Array over-current protective devices (where applicable) – type, location and rating (voltage/current).
Earthing and protection devices	<ul style="list-style-type: none"> • Details of all earth/bonding conductors – size and connection points. This includes details of array frame equipotential bonding cable where fitted. • Details of any connections to an existing Lightning Protection System (LPS). • Details of any surge protection device installed (both on AC and DC lines) to include location, type and rating.
AC system	<ul style="list-style-type: none"> • AC isolator location, type and rating. • AC overcurrent protective device location, type and rating. • Residual current device location, type and rating (where fitted). • Grid connection details and grid code requirements.
Data acquisition and communication system.	<ul style="list-style-type: none"> • Details of the communication protocol. • Wiring requirements. • Sensors and data logging.

7.9

Plant Design Conclusions

The performance of a PV power plant may be optimised by reducing the system losses. Reducing the total loss increases the annual energy yield and hence the revenue, though in some cases it may increase the cost of the plant. In addition, efforts to reduce one type of loss may conflict with efforts to reduce losses of a different type. It is the skill of the plant designer to make compromises that result in a plant with a high performance at a reasonable cost.

For plant design, there are some general rules of thumb. But specifics of project locations—such as irradiation conditions, temperature, sun angles and shading—should be taken into account in order to achieve the optimum balance between annual energy yield and economic return.

It may be beneficial to use simulation software to compare the impact of different module or inverter technologies and different plant layouts on the predicted energy yield and plant revenue.

The solar PV modules are typically the most valuable and portable components of a PV power plant. Safety precautions may include anti-theft bolts, anti-theft synthetic resins, CCTV cameras with alarms and security fencing.

The risk of technical performance issues may be mitigated by carrying out a thorough technical due diligence exercise in which the final design documentation from the EPC contractor is scrutinised (as described in Section 13.2.2).

Case Study 3

Design

It is vital to ensure that suitable technical expertise is brought to bear on every aspect of the plant design through in-house or acquired technical expertise.

In case of the 5 MW project, the most significant of the design flaws were:

Foundations:

- The foundations for the supporting structures consisted of concrete pillars, cast in situ, with steel reinforcing bars and threaded steel rod for fixing the support structure base plates. This type of foundation is not recommended due to the inherent difficulty in accurately aligning numerous small foundations.
- Mild steel was specified for the fixing rods. As mild steel is prone to corrosion, stainless steel rods would have been preferable.

Supporting structures:

- The supporting structures were under-engineered for the loads they were intended to carry; in particular, the purlins sagged significantly under the load of the modules. As supporting structures should be designed to withstand wind loading and other dynamic loads over the life of the project, this was a major problem. Extensive remedial work was required to retrofit additional supporting struts.
- The supporting structure was not adjustable (i.e. no mechanism was included to allow adjustment in the positioning of modules). This is a basic mistake which compounded the flaw in the choice of foundation type; the combination of these two mistakes led to extensive problems when it came to attempting to align the solar modules.

Electrical:

- String diodes were used for circuit protection instead of string fuses. Current best practice is to use string fuses, as diodes cause a voltage drop and power loss, as well as a higher failure rate.
- No protection was provided at the submain or main junction boxes. This means that for any fault occurring between the array junction boxes and the DC distribution boards (DBs), the DBs will trip and take far more of the plant offline than is necessary.
- No load break switches were included on junction box before the DBs. This means it is not possible to isolate the plant at the array, submain or main junction box levels for installation or maintenance.
- The junction boxes did not allow for string monitoring. This reduces fault diagnosis capability.

The design flaws listed above cover a wide range of issues. However, the underlying lesson is that it is vital to ensure that suitable technical expertise is brought to bear on every aspect of the plant design. Should the developer not have all the required expertise in-house, then a suitably experienced technical advisor should be engaged. It is also recommended that, regardless of the level of expertise in-house, a full independent technical due diligence is carried out on the design before construction commences.

It should be borne in mind that it is far cheaper and quicker to rectify flaws at the design stage than during or after construction.

8. PERMITS AND LICENSING

Obtaining the relevant permits and licences is essential to facilitate the timely completion of a project. Clearances also help ensure that the development proceeds in harmony with the natural environment, existing land usage and other regulatory interests.

It is recommended that early stage consultation with key authorities, statutory bodies and other relevant stakeholders is sought. This is valuable in the assessment of project viability, and may guide and increase the efficiency of the development process. Early consultation can also inform the design process to minimise potential environmental impacts and maintain overall sustainability of the project.

8.1 Permitting, Licensing and Regulatory Requirements – General

The exact requirements vary from country to country but the key permits, licences and agreements typically required for renewable energy projects include:

- Land lease contract.
- EIA.
- Building permit/planning consent.
- Grid connection contract.
- Power purchase agreement.

The authorities, statutory bodies and stakeholders that should be consulted also vary from country to country but usually include the following organisation types:

- Local and/or regional planning authority.
- Environmental agencies/departments.
- Archaeological agencies/departments.

- Civil aviation authorities (if located near an airport).
- Local communities.
- Health and safety agencies/departments.
- Electricity utilities.
- Military authorities.

8.2 IFC Performance Standards On Social And Environmental Sustainability

The social and environmental sustainability standards laid down by the International Finance Corporation (IFC) for all its investment projects have set an example for private companies and financial institutions.

The IFC performance standards relate to the following key topics:

- Social and Environmental Assessment and Management System.
- Labour and Working Conditions.
- Pollution Prevention and Abatement.
- Community Health, Safety and Security.
- Land Acquisition and Involuntary Resettlement.
- Biodiversity Conservation and Sustainable Natural Resource Management.
- Indigenous Peoples.
- Cultural Heritage.

Compliance with the IFC performance standards will not only ensure a socially and environmentally sustainable project but will also facilitate the sourcing of finance for the project.

For further detail on the IFC's performance standards see www.ifc.org.

8.3 Permitting, Licensing and Regulatory Requirements – India

The solar PV industry in India is at an early stage of development in a rapidly changing policy and regulatory environment, marked by very significant diversity between different states. As such, it is not practical to describe specific permitting and licensing requirements for all states. Instead, this section gives a broad overview of permitting and licensing requirements relevant to most of the country.

8.3.1 Project Start-up

The following key national and state level bodies should be consulted and the relevant approvals sought to confirm the viability of a project proposal. The aim would be to establish a starting point for the wider permitting and licensing process.

- **Ministry of New and Renewable Energy (MNRE)** – The Indian renewable energy industry is reliant on policies and support mechanisms implemented by the national government. Project allocation and approval from the MNRE forms the first step towards permitting and licensing a solar power project. MNRE has specific requirements to be fulfilled by solar project developers under its generation-based incentives scheme and the National Solar Mission.
- **State Nodal Agencies** – These are state-level agencies facilitating development of renewable energy projects approved by MNRE. Obtaining an approval from the relevant agency is an essential requirement for obtaining other licences and agreements for land lease and grid connection.
- **Ministry of Civil Aviation** – For plants located in the proximity of an airport, an early consultation with the Ministry of Civil Aviation at the time of land assessment is essential to ensure that no objections are raised.

- **Ministry of Defence** – It is recommended that the Ministry of Defence is consulted at the land identification stage. This is necessary to ensure that the land does not lie in an unsafe zone, and the development would have no adverse impact on defence in sensitive areas.

In addition, the following agreements would be required at an early stage to enable the development to proceed.

- **Power Purchase Agreement (PPA)** – This is an important requirement for establishing the viability of the project. In India, under the solar generation-based initiative policy of MNRE, a PPA can be signed with the state utilities. However, the draft guidelines of the National Solar Mission specify that for projects above 5MW, the PPA is signed by NTPC Vidhyut Vyapar Nigam (NVTN). Projects below 5MW can be signed by the state distribution utilities.
- **Land Agreement** – An agreement to procure or lease the necessary land is another key requirement for developing solar projects.

8.3.2 Project Development and Implementation

To progress the project, the developer would need to consult district and local level bodies and seek approvals for development. The relevant authorities, agencies and departments are likely to differ from district to district. Examples of the types of organisations that should be engaged include the following:

- **District Advisory Committee** – A clearance may be required from the district collector confirming that the project would not have an adverse impact on its surroundings.

- **Planning Department** – The project will normally require prior approval from the relevant planning department at town and district levels.
- **Archaeological Department** – Consultation and approval from the relevant archaeological department will confirm that the land acquired for the project is not of historical significance.
- **Fire Safety Authority** – Consultation and approval from the relevant authority may be required with respect to relevant fire safety requirements during construction and operation of the project.
- **Forest Authority** – Consultation and approval from the relevant forest authority may be required if trees are to be felled to prevent any shading of PV plant. It may also be prudent to confirm that the land to be developed has not been reserved for future forestry operations.
- **Pollution Control Board** – Consent from the local pollution control board may be required with respect to wastewater management and noise emission control, particularly during the construction phase of the project.
- **Irrigation Department** – In addition to confirming that land is not subject to any relevant reservation, consultation with the irrigation department may ensure water availability during construction and operation.
- **Industrial Development Corporation** – Early consultation with such authorities at state level may yield indirect benefits to the project, depending on various initiatives taken up by local governments for industrial development.

- **Local Governing Bodies** – In some areas, a project may fall under the jurisdiction of governing bodies for small villages. Consultation with these local bodies is key to getting consent for the project from the local population. Their approval can facilitate work in the construction and operation phases.

In addition, the following requirements should be noted.

- **Construction power requirements** – This specific licence is normally obtained from the state distribution utility for obtaining power required during construction of the plant. Otherwise, stand-alone diesel generators can be utilised with prior permission from the pollution control board.
- **Environmental Impact Assessment** – An assessment of the potential environmental impacts of the development should be undertaken. If required, appropriate mitigation measures should be identified in consultation with relevant stakeholders. As a guideline, projects should adhere to the IFC performance standards (see Section 8.2).

8.3.3 Power Export

- **Grid Connection** – In addition to the power purchase agreement, a grid connection permit from the transmission utility is required for exporting power. This normally specifies and confirms the point and voltage level of connection.
- **Electrical Inspectorate** – Electrical inspectorate approvals ensure safety on all electrical installations. The approvals are likely to be mandatory requirements of the public works department of the state in which the plant is built. These are required through the life cycle—from pre-construction to post-commissioning—of the project.

Case Study 4

Permits and Licensing

There are many permits required for a multi-megawatt PV power plant in India. An indicative, non-exhaustive list of the permits obtained for the 5MW plant built in Tamil Nadu in 2010 is shown in the table below. These apply specifically to this project and permitting will differ in other states. In addition to the permits that are suggested below, there will naturally be permits and licenses required as a result of simply operating a business in India (eg. human resource requirement) which have not been included below in the interest of focus. However, these need to be given equal attention in the development phase.

A lesson learnt in the case of the Tamil Nadu plant was that comprehensive legal advice on the permits is required as well as a stringent management and follow up of the application processes.

It must be noted that some permit requirements were not relevant to the Tamil Nadu plant. Permission from the Ministry of Defence, for example, was not required as the site was not in a militarily sensitive zone.

The majority of the permits were applied for and in place prior to the start of construction. This is deemed best practice and sets a good example for other developers. One permission, involving land access rights, was overlooked. The main access route to the plant was through land owned by another party. Until rights are obtained, the project remains vulnerable to the risk of goodwill being withdrawn.

Some permits were issued on the condition that the plant was to be completed before a certain date. This caused problems when the project was delayed. As a result, a re-application or extension was required. This illustrates the importance of effective planning of projects and scheduling of construction.

Area of Permission	Documents Received	Timing
Ministry of New and Renewable Energy (MNRE)	Letter from MNRE confirming eligibility of the project for generation-based incentive.	Prior to construction
State Nodal Agencies	“In-principle approval” from Tamil Nadu Energy Development Agency (TEDA).	Prior to construction
Ministry of Civil Aviation	Not required as not in civil aviation proximity.	-
Ministry of Defence	Not required due to location of site and land ownership.	-
Power Purchase Agreement (PPA)	PPA from Tamil Nadu Electricity Board (TNEB).	Prior to construction
Land Agreement	Deeds of sale for land.	Various, mainly prior to construction
District Advisory Committee	District Advisory Committee on Renewable Energy issued a no-objection certificate.	Prior to construction
Planning Department	Certification of Land Use by the Director of Town & Country planning.	Prior to construction
Archaeological Department	Not required as no heritage buildings were on site.	-
Forest Authority	Not required as no tree felling was required.	-
Pollution Control Board	The Tamil Nadu Pollution Control Board consented – one consent each for air and water.	Prior to construction
Irrigation Department	Not required as no water courses were diverted.	-
Industrial Development Corporation	Not required as the land was already classified as non-agricultural.	-
Seismic Centre	Published data were incorporated into the design.	-
Local Governing Bodies	No objection received from local <i>Panchayat</i> .	Prior to construction
Construction power requirements	This was not required as a diesel generator was used for construction power requirements.	-
EIA	Submitted.	Prior to construction
Grid Connection	Consent from the Tamil Nadu Electricity Board.	Prior to construction
Electrical Inspectorate	Start-up power and tie-in approval from Tamil Nadu Electricity Board.	
Full approval required after electrically connected.	During and after construction	
Local stakeholders	Consent through meeting.	Prior to construction
Land tax	Land tax receipts for the site and approach road	-
Other	CDM approval from the Ministry of Environment and Forests.	Prior to construction

NB. This list is indicative only.

9. CONSTRUCTION

9.1 Introduction

The management of the construction phase of a solar PV project should be in accordance with general construction project management best practice. Therefore, the aim is to construct the project to the required level of quality, and within the time and cost limits. During construction, issues like environmental impact, and health and safety of the workforce (and other affected people) should also be carefully managed.

The approach to construction project management for a solar PV plant will depend on many factors. Of them, one of the most important is the project contract strategy.

From a developer's perspective, construction project management for a full turnkey EPC contract will be significantly less onerous than that required for a multi-contract approach. However, a multi-contract approach gives the developer greater control over the final plant configuration. Regardless of the contract strategy selected, there are a number of key activities that will need to be carried out, either by the developer or a contractor. These activities are described in the following sections.

Typical EPC contract terms may be found in Appendix C – EPC Contract Model Heads of Terms.

9.2 Interface Management

Interface management is of central importance to the delivery of any complex engineering project, and solar PV projects are no exception. The main interfaces to be considered in a solar PV project are listed in Table 12. It should be noted that the interfaces may differ, depending on the contracting structure and specific requirements of particular projects.

For a multi-contract strategy, the developer should develop a robust plan for interface management. This plan should list all

project interfaces, describe which organisations are involved, allocate responsibility for each interface to a particular individual, and explicitly state when the interface will be reviewed. In general, design and construction programmes should be developed to minimise interfaces wherever possible.

Opting for a turnkey EPC contract strategy will, in effect, pass the onus for interface management from the developer to the EPC contractor. But interface management will remain an important issue and one that requires ongoing supervision. To some extent interfaces between the project and its surroundings (for example grid connection) will remain the responsibility of the developer.

If a turnkey EPC strategy is chosen, then a contractor with a suitable track record in the delivery of complex projects should be selected to minimise this risk. Information should also be sought from potential contractors on their understanding of the project interfaces and their proposed approach to managing them.

9.3 Programme and Scheduling

A realistic and comprehensive construction programme is a vital tool for the construction planning and management of a solar PV project. The programme should be sufficiently detailed to show:

- Tasks and durations.
- Restrictions placed on any task.
- Contingency of each task.
- Milestones and key dates.
- Interdependencies between tasks.
- Parties responsible for tasks.
- Project critical path.
- Actual progress against plan.

Table 12: Solar PV Project Interfaces

Item	Element	Organisations	Interface / Comments
1	Consents	<ul style="list-style-type: none"> • All contractors • Landowner • Planning authority. 	Monitoring of compliance with all planning conditions and permits.
2	Civil Works	<ul style="list-style-type: none"> • Civil contractor • Mounting or tracking system supplier • Central inverter supplier • Electrical contractor • Grid connection contractor • Security contractor 	Site clearance. Layout and requirements for foundations, cable trenches, ducts, roads and access tracks.
3	Security	<ul style="list-style-type: none"> • Civil contractor • Electrical contractor • Security contractor • Communications contractor 	Layout of the security system, including power cabling and communications to the central monitoring system.
4	Module Mounting or Tracking System	<ul style="list-style-type: none"> • Mounting or Tracking system supplier • Civil contractor • Module supplier • Electrical contractor 	Foundations for the mounting or tracking system, suitability for the module type and electrical connections, and security of the modules. Earthing and protection of the mounting or tracking system.
5	Inverter	<ul style="list-style-type: none"> • Civil contractor (for central inverters) • Mounting system supplier (for string inverters) • Module supplier • Inverter supplier • Electrical contractor • Communications contractor 	Foundations for larger central inverters, or suitability for the mounting system. Suitability of the module string design for the inverter. Interface with the communications for remote monitoring and input into the SCADA system.

Table 12: Solar PV Project Interfaces

Item	Element	Organisations	Interface / Comments
6	AC/DC and Communications Cabling	<ul style="list-style-type: none"> Electrical contractor Civil contractor Communications contractor Security contractor 	Liaison with regard to cable routes, sizes, weights, attachments and strain relief requirements.
7	Grid Interface	<ul style="list-style-type: none"> Civil contractor Electrical contractor Inverter supplier Network operator 	Liaison with regard to required layout of building equipment and interface with on-site cabling installed by the site contractor. More interface outside the site boundary for the grid connection cable/line to the network operator's facilities.
8	Communications	<ul style="list-style-type: none"> Electrical contractor Security contractor Communications contractor Owner and Commercial operator 	Interface between the security system, inverter system, central monitoring (SCADA), the monitoring company, and the owner or commercial operator of the PV plant.
9	Commissioning	<ul style="list-style-type: none"> All contractors 	Commissioning of all systems will have several interface issues particularly if problems are encountered.

All tasks and the expected timescale for completion should be detailed along with any restrictions to a particular task. For example, if permits or weather constraints stop construction during particular months.

For a solar PV project, it is likely that the programme will have different levels, incorporating different levels of detail around each of the following main work areas:

- Site access.
- Security.
- Foundation construction.
- Module assembly.
- Mounting frame construction.
- Substation construction.

- Electrical site works.
- Grid interconnection works.
- Commissioning and testing.

A high level programme should be produced to outline the timescales of each task, the ordering of the tasks and any key deadlines. This should be completed as part of the detailed design.

The programme will then be built up to detail all the associated tasks and sub tasks, ensuring that they will be completed within the critical timescale. A thorough programme will keep aside time and resources for any contingency. It will also allocate allowance for weather risk or permit restrictions for each task.

Interdependencies between tasks will allow the programme to clearly define the ordering of tasks. A project scheduling package will then indicate the start date of dependent tasks as well highlighting the critical path.

Critical path analysis is important to ensure that tasks that can affect the overall delivery date of the project are highlighted and prioritised. A comprehensive programme should also take into account resource availability. This will ensure that tasks are scheduled for when required staff or plant are available.

Incorporating a procurement schedule that focuses on items with a long manufacturing lead time (such as transformers, central inverters and modules) will ensure that they are ordered and delivered to schedule. It will also highlight any issues with the timings between delivery and construction, and the need for storage onsite.

To share this information and to save time and effort, it is strongly recommended that an “off-the-shelf” project scheduling package is used.

9.3.1 Milestones

Milestones are goals that are tied in with contractual obligations, incentives or penalties. Incorporating milestones in the programme helps the project team to focus on achieving these goals. In effect, construction must be planned around certain milestones or fixed dates (for example, the grid connection date).

If the contracted milestones are included in the programme, the impact of slippage on these dates will be apparent. Appropriate budgetary and resourcing decisions can then be made for those delays. The milestones can also indicate when payments are due to a contractor.

9.3.2 Planning and Task Sequencing

Appropriate sequencing of tasks is a vital part of the planning process. The tasks must be sequenced logically and efficiently. The overall sequence of works is generally: site access, site clearance, security, foundation construction, cable trenches and ducts, substation construction, mounting frame construction, electrical site works, communications, onsite grid works and then testing and commissioning. Each of these work areas should be broken down into a series of sub-tasks. Alongside, an assessment of the inputs required for each task (especially when interfaces are involved) will help develop a logical and efficient sequence.

Consideration should also be given to any factors that could prevent or limit possible overlap of tasks. These factors could include:

- Access requirements.
- Resource availability (plant and manpower).
- Planning (or other regulatory) restrictions.
- Safety considerations.

9.3.3 Risk Management

The risks associated with the project should be identified, assessed and managed throughout the construction process. The hazards need to be incorporated in the planning and scheduling of the project. Each aspect of the project should be assessed for likelihood and impact of potential risks. The next step would be to develop a suitable action plan to mitigate identified risks. If a particular risk could affect the delivery of the whole project, alternatives for contingency (in terms of time and budget) should be included.

9.4 Cost Management

The viability of a solar project will be affected by the duration of the construction period. During construction, the project will be in debt owing to interest and finance

charges, and lack of income to make payments. Therefore, a shorter construction period is generally preferable. The period of construction also requires prudent cost management, which is tied in with the project schedule and the contracted payment structure.

The payment structure will depend upon the type of contract opted for, but is likely to involve milestone payments. The typical range of EPC payment schedules is detailed in Table 13. If a multi-contract strategy is chosen, then a similar structure for phased-out payments for each contract is advisable.

This schedule shows that a high percentage of the payments are made once the goods have been delivered to site. It also allows enough money to be held back to ensure that the contractor completes the works.

The tools used for construction cost management in a solar PV venture are the same as for any major engineering project. These can include:

Earned value management – This is an approach based on monitoring the project plan, actual work completed and work-completed value to assess if a project is on track. Earned value management indicates how much of the budget (and available time) should have been spent, with regards to the amount of work done to date. This method necessitates advance calculation of both the baseline cost for a task and the resources required. If used correctly, this is a powerful tool for estimating and controlling project overspends as early as possible in the construction period.

Completion certificates – Completion certificates are issued once the entire (or a specific) part of the plant is physically complete. These certificates are issued prior to any tests taking place and confirm that the contractor has installed the equipment correctly. They may only be for a specific part of the project (for example a string of modules). Payment for a particular item of work will not be made until the appropriate completion certificate has been issued.

Table 13: Typical EPC Payment Schedule

Payment	Payment Due Upon	% of Contract Price
1	Advance payment (commencement date)	10-20
2	Civil works completed	10-20
3	Delivery of components to site (probably on a pro-rata basis)	40-60
4	Modules mechanically complete	5-15
5	Modules electrically complete	5-15
6	Provisional completion and commercial operation	5-10
6	Solar PV plant taken over	5-10

Snagging lists – Compiling “Snag Lists” as an ongoing exercise is recommended. A prerequisite to the hand-over phase, this list is a process of monitoring and tracking any defects. These should be addressed and rectified to the satisfaction of the developer. In some cases, the take-over will occur with some minor defects still outstanding. In such a scenario, the snagging list will detail these minor defects, which will then have to be addressed within a stipulated period.

Take-Over certificates – Take-over certificates will be issued by the contractor for acceptance by the developer. These will be issued once all tests have been completed and defects addressed. It is normal for the power purchaser to request a copy of the take-over certificate. To expedite the launch of the project, the developer may choose to take over a project with minor snags, subject to the contractor taking responsibility to complete them. While this conditionality is acceptable, progress in addressing defects should be monitored.

9.5 Contractor Warranties

The owner of a PV power plant will typically use the services of an EPC contractor to design and build a project. He will also require an O&M contractor to operate and maintain the plant during its operational phase.

The EPC contractor offers project planning services, and will provide the necessary engineering for project design. The contractor will typically be responsible for material selection and procurement of modules, inverters, and balance of plant components. Construction may be carried out by the EPC contractor or through partnerships with local installation and project development companies (in this case, the EPC contractor will provide on-site inspection). Warranties within the EPC contract may include a Defect Warranty, Module Capacity Warranty, Performance Ratio Warranty and Structure Warranty as described in Table 14.

Table 14: Warranty Types and Requirements

Warranty Type	Details
Defect warranty	The contractor warrants that the plant will be free from defects in materials and workmanship, and that the project will adhere to the qualities set out in a technical specifications document.
Module capacity warranty	The contractor may guarantee that the total peak capacity of the project within a certain time period after completion is not less than a certain value, and may also certify that the degradation will not exceed a given value during the warranty period.
Performance ratio warranty	The contractor guarantees that the PR as measured during a PR test will not be less than a given value, and that the PR shall not reduce by more than a given percentage during the warranty period.
Structure warranty	The contractor warrants the structural integrity of elements of the works for a given period.

9.5.1 Warranty Duration

Warranties for EPC contracts are typically in the two to five year range. If the O&M contractor is also the EPC contractor, it can be easier to enforce these warranties. However, if they are separate companies, the exclusions to the warranties should be checked carefully. Also, the maintenance carried out by the O&M contractor should be in compliance with the EPC contractor's requirements.

The original manufacturer's warranties on components such as inverters, support structures and modules should be passed from the EPC contractor to the plant owner at handover. Acceptance testing is often completed before the plant is handed over to the owner.

Even in a multiple contract structure, the component warranties described in Table 14 above would be applicable and should be incorporated. However, these warranties will be contract-specific, and need to be decided upon before tendering for the work. This is a judicious way to ensure that the guarantees provided are on a par with those expected by the developers.

9.6 Quality Management

Controlling construction quality is essential for the success of the project. The required level of quality should be defined clearly and in detail in the contract specifications.

A quality plan is an overview document (generally in a tabular form), which details all works, deliveries and tests to be completed within the project. This allows work to be signed off by the contractor and enables the developer to confirm if the required quality procedures are being met. A quality plan will generally include the following information:

- Tasks (broken into sections if required).
- Contractor completing each task or accepting equipment.

- Acceptance criteria.
- Completion date.
- Details of any records to be kept (for example, photographs or test results).
- Signature or confirmation of contractor completing tasks or accepting delivery.
- Signature of person who is confirming tasks or tests on behalf of the developer.

Quality audits should be completed regularly. These will help developers verify if contractors are completing their works in line with their quality plans. Audits also highlight quality issues that need to be addressed at an early stage. Suitably experienced personnel should undertake these audits.

9.7 Environmental Management

The IFC Environmental, Health, and Safety (EHS) Guidelines are technical reference documents with general and industry-specific examples of good international industry practice. With respect to environmental management, the guidelines cover the following areas:

- General Guidelines.
- Air Emissions and Ambient Air Quality.
- Energy Conservation.
- Wastewater and Ambient Water Quality.
- Water Conservation.
- Hazardous Materials Management.
- Waste Management.
- Noise Emissions.
- Contaminated Land.

It is recommended that these guidelines are followed as a benchmark, along with any specific local guidelines and information from the EIA.

As for quality management, contractors should be urged to develop an environmental management plan (addressing the areas listed above), against which their performance can be monitored.

9.8 Health and Safety Management

The health and safety of the project work force and other affected people should be carefully overseen by the project developer. Apart from ethical considerations, the costs of not complying with health and safety legislation can represent a major risk to the project. Furthermore, a project with a sensitive approach to health and safety issues is more likely to obtain international financing.

The IFC EHS guidelines cover two main areas of health and safety: occupational health and safety and community health and safety. The issues covered under these areas are listed below.

Occupational Health and Safety:

- General Facility Design and Operation.
- Communication and Training.
- Physical Hazards.
- Chemical Hazards.
- Biological Hazards.
- Personal Protective Equipment (PPE).
- Special Hazard Environments.
- Monitoring.

Community Health and Safety:

- Water Quality and Availability.
- Structural Safety of Project Infrastructure.
- Life and Fire Safety (L&FS).
- Traffic Safety.
- Transport of Hazardous Materials.
- Disease Prevention.
- Emergency Preparedness and Response.

The IFC guidelines give guidance on how each of these aspects of H&S should be approached, outline minimum requirements for each aspect and list appropriate control measures that can be put in place to reduce risks.

As a minimum standard, compliance with local H&S legislation should be rigorously enforced. Where local legal requirements are not as demanding as the IFC guidelines, it is recommended that the IFC guidelines be followed.

9.9 Specific Solar PV Construction Issues

The following sections describe common pitfalls or mistakes that can occur during the construction phase of a solar PV project. Most of these pitfalls can be avoided by appropriate design, monitoring, quality control and testing on site.

9.9.1 Civil

The civil works relating to the construction of a solar PV plant are relatively straightforward. However, there can be serious and expensive consequences if the foundations and road networks are not adequately designed for the site. The main risks lie with the ground conditions. Importantly, ground surveys lacking in meticulous detailing or proper interpretation could lead to risks such as unsuitable foundations.

Used land also poses a risk during the civil engineering works. Due to the nature of digging or pile driving for foundations, it is important to be aware of hazardous obstacles or substances below the surface. This is especially important in former industrial sites or military bases.

9.9.2 Mechanical

The mechanical construction phase usually involves the installation and assembly of mounting structures on the site. Some simple mistakes can turn out to be costly, especially if these include:

- Incorrect use of torque wrenches.
- Cross bracing not applied.
- Incorrect orientation.

If a tracking system is being used for the mounting structure, other risks include:

- Lack of clearance for rotation of modules.
- Actuator being incorrectly installed (or as specified), resulting in the modules moving or vibrating instead of locking effectively in the desired position.

These mistakes are likely to result in remedial work being required before hand-over and involve extra cost.

9.9.3 Electrical

Cables should be installed in line with the manufacturer's recommendations. Installation should be done with care as damage can occur when pulling the cable into position. The correct pulling tensions and bending radii should be adhered to by the installation contractor to prevent damage to the cable. Similarly, cables attached to the mounting structure require the correct protection, attachment and strain relief to make sure that they are not damaged.

Underground cables should be buried at a suitable depth (generally between 500mm and 1,000mm) with warning tape or tiles placed above and marking posts at suitable intervals on the surface. Cables may either be buried directly or in ducts. If cables are buried directly, they should be enveloped in a layer of sand or sifted soil should be included to avoid damage by backfill material.

Comprehensive tests should be undertaken prior to energisation to verify that there has been no damage to the cables.

9.9.4 Grid Connection

The grid connection will generally be carried out by a third party over whom the project developer will have limited control. Close communication with the grid connection contractor is essential to ensure that the grid requirements are met. Delay in the completion of the grid connection will affect the energisation date, which will delay the start of commercial operation.

9.9.5 Logistical

Logistical issues can arise if designs or schedules have not been well-thought through. Issues that may arise include:

- Lack of adequate clearance between rows of modules for access.
- Constrained access due to inclement weather conditions.
- For larger tracking systems and central inverters, cranes may be required. Therefore, suitable access and manoeuvrability room within the site is essential (see Figure 24).



Figure 24: Spacing Between Module Rows

9.10 Construction Supervision

It is recommended that the owner and lenders of the project are kept informed of developments during construction. Construction supervision may be carried out by in-house resources. Alternatively, a “technical advisor” or “owner’s engineer” may be commissioned to carry out the work on their behalf.

The role of the technical advisor during the construction phase is to ensure contractor compliance with the relevant contracts, as well as to report on progress and budget. The construction supervision team would generally comprise of a site engineer supported by technical experts in an office. The main parts of the technical advisor’s role are: review of proposed designs, construction monitoring and witnessing of key tests.

Design reviews will generally be carried out on:

- Design basis statements.
- Studies/investigations.
- Design specifications.
- Design of structures.
- Drawings (all revisions).
- Calculations.
- Execution plans.
- Risk assessments and method statements.
- Quality plans.
- Safety plans/reports.
- Material and equipment selection.
- O&M manuals.
- Test reports.

The objective of the design review is to ensure that the contractor has designed the works in accordance with the contract agreements and relevant industry standards. It also aims to ascertain that the works will be suitably resourced and sequenced to deliver the project as specified. The design review could also cover specific areas such as grid compliance or geotechnical issues, depending upon the specific project requirements and experience of the developers.

Key stages and tests for witnessing will include:

- Inspection of road construction.
- Inspection of foundations.
- Verification of cable routes.
- Inspection of cable tracks.
- Witnessing of delivery/off-load of solar modules, transformers, inverters and switchgear.
- Inspection of module, switchgear and inverter installation.
- Witnessing of site acceptance tests.
- Witnessing of completion tests.
- Monitoring and expediting defects.

Besides the owner's engineer, the lender's engineer has the additional role of signing off and issuing certificates that state the percentage of the project completed. These certificates are required by the lenders prior to releasing funds in accordance with the project payment milestones.

Case Study 5

Construction and Project Management

The 5MW PV power plant in Tamil Nadu was constructed during 2010. At commencement, construction was projected to be completed within 38 weeks; due to various factors, many of which are covered in the case studies in this book, construction ended up taking approximately 52 weeks – a significant and costly delay. In addition, the constructed plant suffered from serious quality issues. The construction schedule should be carefully thought through by suitably experienced personnel. It is also recommended that project management software tools are used as these enable the developer to track the progress of a project, identify resource constraints and understand the impact of uncompleted tasks.

The main causes of the construction delays were:

- Design flaws. Poor design of components, such as the support structures, lead to costly and time-consuming remedial measures.
- Poorly planned construction schedule. The illogical sequencing of construction tasks caused a number of delays:

- Monsoon rains restricted access to the site as the access road had not been sealed. The access route should have been sealed well before the arrival of the monsoon.
- Modules were damaged (and were at risk of theft) as they were stored unprotected on site for long periods of time. Modules and other valuable components should not be delivered to site until shortly before they are required. If they must be delivered earlier then they should be stored in a controlled and secure environment.

The constructed plant suffered from a range of serious quality issues. These included:

- Foundations in incorrect locations.
- Poor alignment of foundations.
- Cracked and damaged foundations.
- Elements of the supporting structure left unattached.
- Poorly aligned solar modules.
- Damaged solar modules.
- Poor attention to detail in finishing of substation buildings.

While a wide range of factors undoubtedly contributed to each of these issues, the following factors are considered to have been particularly significant:

- Design quality. Certain basic aspects of the design led directly to construction quality issues. The clearest example of this is the design of the foundations and substructures leading to misalignment of the modules. These problems could have been avoided if suitable expertise had been used in the design stage.
- Design documentation and document control. It is preferable to have a full set of “for construction” design drawings before construction commences. Throughout the construction process, it is vital that document management is thoroughly carried out; in particular, design changes and revision of drawings should be rigorously controlled. The failure to do this led to basic mistakes such as foundations being constructed in the wrong locations.
- Contractor capability. It is fundamentally important to select a suitably experienced and capable construction contractor. Ideally, a contractor with demonstrable experience of similar projects should be selected. In any case, potential contractors’ proposed approach to quality management should be thoroughly scrutinised during the contractor selection process.
- Project Management – supervision / monitoring. Regardless of the capability of the selected contractor, the developer must monitor construction progress closely. Suitably experienced personnel should regularly inspect the progress and quality of the works (and the completeness of the quality records) as they progress. If the developer does not have suitable resources in-house to carry out construction supervision then they should engage a competent party to do it on their behalf.

10. COMMISSIONING

The commissioning process certifies that the project owner's requirements have been met, the power plant installation is complete and the power plant complies with grid and safety requirements. Successful completion of the commissioning process is often considered to be part of the provisional or final acceptance of the PV plant.

Commissioning should follow the procedure described in IEC 62445 and prove three main criteria:

1. The power plant is structurally and electrically safe.
2. The power plant is sufficiently robust (structurally and electrically) to operate for the specified lifetime of a project.
3. The power plant operates as designed and its performance is as expected.

Critical elements of a PV power plant that require commissioning include:

- Module strings.
- Inverters.
- Transformers.
- Switchgear.
- Lightning protection systems.
- Earthing protection systems.
- Electrical protection systems.
- Grid connection compliance protection and disconnection systems.
- Monitoring systems (including irradiation sensors).
- Support structure and tracking systems (where employed).

Inverter commissioning should follow the protocol described in the inverter installation manual. Tasks may include:

- Checking inverter cabling for conformity to schematic diagrams.
- Checking that cable connections are firm.
- Checking DC voltages for polarity and verifying that they are approximately the same for each string. Voltages must not exceed the maximum voltage of the inverter.
- Checking AC grid voltage. AC voltage measurements between the external conductors should be approximately the same as the nominal voltage of the inverter.
- Checking the internal AC power supply.
- Mounting the inverter panelling.
- Inserting fuses or insulation blades (if applicable).
- Switching on the voltage supply by turning on the grid monitoring circuit breaker (if applicable) and the external voltage supply circuit breaker. Status lights should not be showing a fault.
- Switching on the inverter and checking for power export to the grid (if the irradiation level is above the inverter threshold) and for any abnormal noise.

With the exception of the module strings, the commissioning of the remaining plant components follows standard procedures for power plant (the guide does not dwell further on the details). The following sections provide an overview of the pre-connection and post-connection acceptance testing and documentation requirements for the module strings.

10.1 General Recommendations

Commissioning should start immediately after installation has been completed or, where appropriate, sequentially as strings are connected. For power plants employing modules which require a settling-in period, for example, thin film amorphous silicon modules, performance testing should begin once the settling in period has been completed and the modules have degraded.

Since irradiance has an impact on performance, tests should be carried out under stable sky conditions. The temperature of the cells within the modules should be recorded in addition to the irradiance and time.

Ideally, commissioning should be carried out by an independent specialist third party selected by the owner. It should include both visual and electrical testing. In particular, visual testing should be carried out before any system is energised. The testing outlined in this section does not preclude local norms which will vary from country to country.

Test results should be recorded as part of a signed-off commissioning record. While an independent specialist would be expected to carry out these tests, it is important that the developer and owner are aware of them and make sure that the required documentation is completed, submitted and recorded.

10.2 Pre-Connection Acceptance Testing

Prior to connecting the power plant to the grid, electrical continuity and conductivity should be checked by the electrical contractor. Once completed, pre-connection acceptance testing should be carried out on the DC side of the

inverters. These tests according to IEC 62446 should include:

- Open Circuit Voltage Test.
- Short Circuit Current Test.

10.2.1 Open Circuit Voltage Test

This test checks whether all strings are properly connected (module and string polarity) and whether all modules are producing the voltage level as per the module data sheet. The test should be conducted for all strings.

The open circuit voltage, V_{oc} , should be recorded and compared with temperature adjusted theoretical values.

10.2.2 Short Circuit Current test

This test verifies whether all strings are properly connected and the modules are producing the expected current. The test should be conducted for all strings.

The short circuit current, I_{sc} , should be recorded and compared with the temperature adjusted theoretical values.

10.3 Grid Connection

Grid connection should only be performed once all DC string testing has been completed. It is likely that the distribution or transmission system operator will wish to witness the connection of the grid and/or the protection relay. Such a preference should be agreed in advance as part of the connection agreement.

The grid connection agreement often stipulates the level of parameters—such as electrical protection, disconnection and fault—to which the PV power plant is required to adhere. Usually, these conditions need to be met before commissioning the grid connection.

10.4 Post Connection Acceptance Testing

Once the power plant is connected to the grid, the inverters will be powered up according to the manufacturer's start-up sequence. Inverter internal meters and displays should be verified prior to use.

Post grid connection should include:

- DC current test.
- Performance ratio test.

10.4.1 DC Current Test

This test verifies whether all strings are producing adequate and consistent operating current as per the module data sheets. The test should be conducted for all strings.

The string current values per inverter will be checked against the average values of all strings connected to the same inverter and checked against acceptance criteria.

10.4.2 Performance Ratio Test

This test checks if the power plant is performing at or above the performance ratio agreed or warranted within the EPC contract.

A standard testing period would be continuous testing for a minimum of ten consecutive days. Typically, a minimum irradiance will be defined and the performance ratio measured for the period in which that irradiance is exceeded.

The electrical energy generated should be recorded at the metering point (or as agreed in the contract documentation) and compared with the guaranteed value provided by the EPC contractor. An adjustment can be made to account

for the temperatures observed during the test. This is known as the adjusted performance ratio. The electrical energy generated is typically considered to be acceptable if it is within $\pm 3\text{-}5\%$ of the value given by the agreed temperature adjusted performance ratio.

If there are significant differences between the contractual and actual adjusted performance ratio, the EPC contractor should identify and rectify the discrepancy before repeating the performance ratio test.

10.4.3 Availability Test

An availability test should be performed in parallel with the performance ratio test as described above. This will confirm that an acceptable availability is being achieved according to guaranteed values. The test will typically be performed for a minimum of ten consecutive days under stable sky conditions.

The availability of the system can be defined using the formula:

$$\text{Measured Average Availability} = 100\% * \frac{(\text{Power export time} + \text{Time in which power is not exported due to reasons beyond control})}{(\text{Theoretical time for which power may be exported})}$$

10.5 Provisional Acceptance

The completion of the commissioning tests outlined above often forms part of the acceptance tests for the PV power plant. In some instances, the performance ratio test will

be repeated after a period of operation. In such a case, the completion of the commissioning tests marks the provisional acceptance of the PV power plant. The final acceptance takes place after a successful repeated performance ratio test. The period of operation between the two tests is dependent on the contract with the EPC contractor and the level of risk taken on the components of the PV power plant.

For example, a PV power plant with a new technology, an untested module manufacturer or a new EPC contractor may carry a larger degree of technology risk. Therefore, repeating the performance ratio test after one or two year's operation helps identify degradation and teething problems.

10.6 Handover Documentation

The commissioning record^[50] should be handed over to the developer once commissioning is complete, having been signed by the authorised signatory to confirm that the work is satisfactory. Where appropriate, the O&M contractor should be informed of any system performance issues.

The commissioning record is typically submitted along with other handover documentation, which should include:

- The O&M manual.
- Conformity and guarantee certificates.
- Warranty documentation.
- Performance guarantees.
- Monitoring compliance certificates.

[50] The commissioning record is a checked-off list of tasks that that have been completed as part of the commissioning process.

11. OPERATION AND MAINTENANCE

Compared to most other power generating technologies, PV plants have low maintenance and servicing requirements. However, proper maintenance of a PV plant is essential to optimise energy yield and maximise the life of the system.

Maintenance can be broken down as follows:

- **Scheduled or preventative maintenance** – Planned in advance and aimed at preventing faults from occurring, as well as keeping the plant operating at its optimum level.
- **Unscheduled maintenance** – Carried out in response to failures.

Suitably thorough scheduled maintenance should minimise the requirement for unscheduled maintenance although, inevitably, some failures still occur. A robust and well-planned approach to both scheduled and unscheduled maintenance is important.

11.1 Scheduled/Preventative Maintenance

The scheduling and frequency of preventative maintenance is dictated by a number of factors. These include the technology selected, environmental conditions of the site, warranty terms and seasonal variances. The scheduled maintenance is generally carried out at intervals planned in accordance with the manufacturers' recommendations, and as required by the equipment warranties. Scheduled maintenance should be conducted during non-peak production periods and, where possible, at night.

Although scheduled maintenance will both maximise production and prolong the life of the plant, it does represent a cost to the project. Therefore, the aim should be to seek the optimum balance between cost of scheduled maintenance and increased yield through the life of the system.

Specific scheduled maintenance tasks are covered in the following sections.

11.1.1 Module Cleaning

Module cleaning is a simple but important task. It can produce significant and immediate benefits in terms of energy yield.

The frequency of module cleaning will depend on local site conditions (for example, prevalence of dust or rain) and the time of year. As the soiling of modules is site – specific, the duration between clean-ups is likely to vary between sites. However, it is generally recommended to clean the modules at least twice annually. Figure 25 shows the solar panel covered with dust. When scheduling module cleaning, consideration should be given to the following:

- Environmental and human factors (for instance, autumn fall debris and soiling from local agricultural activities).
- Weather patterns: cleaning during rainy periods is less likely to be required.
- Site accessibility based upon weather predictions.
- Availability of water and cleaning materials.

If the system efficiency is found to be below the expected efficiency, then module cleaning should be scheduled as necessary.

The optimum frequency of module cleaning can be determined by assessing the costs and benefits of conducting the procedure. The benefit of cleaning should be seen in an improved performance ratio due to the lower soiling loss—and resultant increase in revenue). A cost estimate to clean all the modules at the PV plant should be obtained from the cleaning contractor. If the cost to clean is less than the increased revenue then it is beneficial to clean the modules.



Figure 25: Solar Panel Covered with Dust

11.1.2 Module Connection Integrity

Checking module connection integrity is important for systems that do not have string level monitoring. This is more likely for central inverter systems for which no string monitoring at the junction/combiner boxes has been designed. In such cases, faults within each string of modules may be difficult to detect. Therefore, the connections between modules within each string should be checked periodically (this may include measuring the string current).

11.1.3 Junction or String Combiner Box

All junction boxes or string combiner boxes should be checked periodically for water ingress, dirt or dust accumulation and integrity of the connections within the boxes. Loose connections could affect the overall performance of the PV plant. Any accumulation of water, dirt or dust could cause corrosion or short circuit within the junction box.

Where string level monitoring is not used, periodic checks on the integrity of the fuses in the junction boxes, combiner boxes and, in some cases, the module connection box should be conducted.

11.1.4 Hot Spots

Potential faults across the PV plant can often be detected through thermography. This technique helps identify weak and loose connections in junction boxes and inverter connections. It can also detect hot spots within inverter components and along strings of modules that are not performing as expected.

Thermography should be conducted by a trained specialist using a thermographic camera.

11.1.5 Inverter Servicing

Generally, inverter faults are the most common cause of system downtime in PV power plants. Therefore, the scheduled maintenance of inverters should be treated as a centrally important part of the O&M strategy.

The maintenance requirements of inverters vary with size, type and manufacturer. The specific requirements of any particular inverter should be confirmed by the manufacturer and used as the basis for planning the maintenance schedule.

The annual preventative maintenance for an inverter should, as a minimum, include:

- Visual inspections.
- Cleaning/replacing cooling fan filters.
- Removal of dust from electronic components.
- Tightening of any loose connections.
- Any additional analysis and diagnostics recommended by the manufacturer.

11.1.6 Structural Integrity

The module mounting assembly, cable conduits and any other structures built for the PV plant should be checked periodically for mechanical integrity and signs of corrosion. This will include an inspection of support structure foundations for evidence of erosion from water run-off.

11.1.7 Tracker Servicing

Similarly, tracking systems also require maintenance checks. These checks will be outlined in the manufacturers' documentation and defined within the warranty conditions. In general, the checks will include inspection for wear and tear on the moving parts, servicing of the motors or actuators, checks on the integrity of the control and power cables, servicing of the gearboxes and ensuring that the levels of lubricating fluids are suitable.

The alignment and positioning of the tracking system should also be checked to ensure that it is functioning optimally. Sensors and controllers should be checked periodically for calibration and alignment.

11.1.8 Balance of Plant

The remaining systems within a PV power plant, including the monitoring and security systems, auxiliary power supplies, and communication systems should be checked and serviced regularly. Communications systems within the PV power plant and to the power plant should be checked for signal strength and connection.

11.1.9 Vegetation Control

Vegetation control and ground keeping are important scheduled tasks for solar PV power plants since there is a strong likelihood for vegetation (for example, long grass, trees or shrubs) to shade the modules. The ground keeping can also reduce the risk of soiling (from leaves, pollen or dust) on the modules.

11.2 Unscheduled Maintenance

Unscheduled maintenance is carried out in response to failures. As such, the key parameter when considering unscheduled maintenance is diagnosis, speed of response and repair time. Although the shortest possible response is preferable for increasing energy yield, this should be balanced against the likely increased contractual costs of shorter response times.

The agreed response times should be clearly stated within the O&M contract and will depend on the site location—and whether it is manned. Depending on the type of fault, an indicative response time may be within 48 hours, with liquidated damages if this limit is exceeded.

The majority of unscheduled maintenance issues are related to the inverters. This can be attributed to their complex internal electronics, which are under constant operation. Depending on the nature of the fault, it may be possible to rectify the failure remotely – this option is clearly preferable if possible.

Other common unscheduled maintenance requirements include:

- Tightening cable connections that have loosened.
- Replacing blown fuses.
- Repairing lightning damage.
- Repairing equipment damaged by intruders or during module cleaning.
- Rectifying SCADA faults.
- Repairing mounting structure faults.
- Rectifying tracking system faults.

The contractual aspects of unscheduled O&M are described in more detail below.

11.3 Spares

In order to facilitate a rapid response, a suitably stocked spares inventory is essential. The numbers of spares required will depend on the size of the plant and site-specific parameters. Adequate supplies of the following components should be held:

- Mounting structure pieces.
- Junction/combiner boxes.
- Fuses.
- DC and AC cabling components.
- Communications equipment.
- Modules (in case of module damage).
- Spare inverters (if string inverters are being used).
- Spare motors, actuators and sensors should also be kept where tracking systems are used.

It is important that spares stock levels are maintained. Therefore, when the O&M contractor uses some spares he should replenish the stocks as soon as possible. This arrangement will reduce the time gap between the identification of the fault and replacement of the non-operational component. This can be of particular relevance for remote locations with poor accessibility and adverse weather conditions. Consultation with manufacturers to detail the spare parts inventory, based upon estimated component lifetimes and failure rates, is recommended.

11.4 Performance Monitoring, Evaluation and Optimisation

To optimise system performance, there is a need to ensure that the plant components function efficiently throughout the lifetime of the plant. Continuous monitoring of PV systems is essential to maximise the availability and yield of the system.

Section 7.6.1 describes some of the information required for an effective monitoring system. A SCADA system is able to monitor the real-time efficiency and continuously compare it with the theoretical efficiency to assess if the system is operating optimally. This information can be used by the O&M contractor to establish the general condition of the system and schedule urgent repair or maintenance activities such as cleaning.

11.5 Contracts

This section describes the key issues for consideration with regards to O&M contracts. A model O&M contract is included in Appendix D – O&M Contract Model Heads of Terms.

It is common for the O&M of PV plants to be carried out by specialist O&M contractors. The contractor will be responsible for the operation and maintenance of the whole plant. This is likely to include:

- Modules and mounting frames or tracking system.
- Inverters.
- DC and AC cabling.
- String combiner or junction boxes.
- Site SCADA system, remote monitoring and communication systems.
- Site substation.
- Site fencing and security system.
- Auxiliary power supply.
- Site access routes and internal site roads.
- Site building and containers.
- Vegetation control.
- Maintenance of fire-fighting equipment or reservoirs.

11.5.1 Purpose

The purpose of an O&M contract is to optimise the performance of the plant within established cost parameters. To do this effectively, the contract must be suitably detailed and comprehensive. In particular, the O&M contract should clearly set out:

- Services to be carried out by and obligations on the contractor.
- Frequency of the services.
- Obligations on the owner.
- Standards, legislation and guidelines to which the contractor must comply.
- Payment structure.

- Warranties and operational targets.
- Terms and conditions.
- Legal aspects.
- Insurance requirements and responsibilities.

These issues are discussed in the following sections.

11.5.2 Contractor Services and Obligations

The O&M contract should list the services to be performed by the contractor. This list should be site-specific and include the following:

- Plant monitoring requirements.
- Scheduled maintenance requirements.
- Unscheduled maintenance requirements.
- Agreed targets (for example, response time or system availability).
- Reporting requirements (including performance, environmental, and health and safety reporting).

It should be stipulated that all maintenance tasks shall be performed by the contractor in such a way that their impact on the productivity of the system is minimal. In particular, the contract should stipulate that maintenance tasks should be kept to a minimum during the hours of sunlight.

The O&M contract will typically define the terms by which the contractor is to:

- Provide, at intervals, a visual check of the system components for visible damage and defects.
- Provide, at intervals, a functional check of the system components.
- Ensure that the required maintenance will be conducted on all components of the system. As a minimum, these activities should be in line with manufacturer recommendations and the conditions of the equipment warranties.

- Provide appropriate cleaning of the modules and the removal of snow (site specific).
- Make sure that the natural environment of the system is maintained to avoid shading and aid maintenance activities.
- Replace defective system components and system components whose failure is deemed imminent.
- Provide daily remote monitoring of the performance of the PV plant to identify when performance drops below set trigger levels.

11.5.3 Obligations on the Owner

In an O&M contract for a PV plant, the obligations on the owner/developer are generally limited to:

- Granting the O&M contractor access to the system and all the associated land and access points.
- Obtaining all approvals, licences and permits necessary for the legal operation of the plant.
- Providing the O&M contractor with all documents and information available to them and necessary for the operational management of the plant.

11.5.4 Standards, Legislation and Guidelines

This section of the contract outlines the various conditions to which the O&M contractor must comply while carrying out the O&M of the plant. These conditions are contained within the following documentation:

- Building or construction permits.
- Planning consents and licences.
- Grid connection statement, the grid connection agreement and PPA (or similar).
- System components installation handbooks.
- Applicable legislation.

- Local engineering practices (unless the documents and conditions listed above require a higher standard).

11.5.5 Payment

The cost and remuneration of the O&M contract is generally broken down in to:

- Fixed remuneration and payment dates.
- Other services remuneration and expenditure reimbursement.

Fixed remuneration outlines the payment for the basic services that are to be provided by the maintenance contractor under the O&M contract. This section should include the following:

- Cost – this is usually a fixed price per kWp installed.
- Payment structure (that is, monthly, quarterly or annually).
- Payment indexation over the duration of the contract.

Remuneration for other services includes payment for any services above the basic requirement. This should include:

- Method for determining level of other services carried out.
- Agreed rates for conducting these services.
- Agreed method for approving additional expenses or services with the owner.
- Any required spare parts and other components that are not covered by individual warranties.

11.5.6 Warranties

An availability warranty can be agreed between the maintenance contractor and the owner of the system. It then becomes the responsibility of the maintenance contractor

to make sure that the system operates at a level greater than the agreed value. If the system operates below the warranted level, then the maintenance contractor may be liable to pay a penalty.

11.5.7 Legal

The contract will have a section outlining the governing law and jurisdiction of the O&M contract. The governing law is normally the law of the country in which the project is located. A legal succession or a transfer of rights condition is required for the developer to reserve the right to assign the O&M contract to a third party.

It is also recommended that every contract has a non-disclosure agreement. This agreement between the O&M contractor and the developer will outline the information that is to be treated as confidential and that which could be disclosed to third parties.

11.5.8 Insurance

The contract should have a section outlining the insurance responsibilities of the contractor for the operations and maintenance activities. This insurance should cover damage to the plant, as well as provide cover for employees conducting the maintenance.

It is normal for the O&M contractor to also arrange and pay for the full site insurance.

11.5.9 Term of Agreement

Every O&M contract needs to have a section that outlines when the O&M contract shall become effective and the duration of the contract from the effective date. This section should also include provisions to renew or extend the contract upon conclusion of the originally agreed term.

It is also recommended that this section includes the circumstances in which either the maintenance contractor or the developer would be entitled to terminate the contract.

11.5.10 Response Time

The guaranteed response time of a maintenance contractor is an important component of the O&M contract. As soon as notification of a fault occurs, it is the responsibility of the contractor to go to the site within a set period of time. The faster the response time, the swifter the issues can be diagnosed and resolved towards the aim of returning the system to full production. The distance between the PV plant and the contractor's premises has a direct correlation to the duration of the guaranteed response time.

The time of year coupled with the accessibility to the site can have a bearing on the actual response time for any unscheduled maintenance event. Restrictions in access roads, at certain times of the year, can delay response. Adverse conditions can also reduce the size of the payload that can be transported to the site, thus extending the duration of the maintenance work.

11.5.11 Selecting a Contractor

When choosing an O&M contractor, his experience should be thoroughly examined. In particular, the following aspects should be considered:

- Familiarity of the contractor with the site and equipment.
- Location of the contractor's premises.
- Number of staff.
- Level of experience.
- Financial situation of the contractor.

The intention should be to select a suitably experienced contractor able to meet the requirements of the contract for the duration of the project.

11.6

Operations and Maintenance Conclusions

It is important to define the parameters for the operation and maintenance of a PV project during its life. These conditions must, as a minimum, cover the maintenance requirements to ensure compliance with the individual component warranties and EPC contract warranties. If an O&M contractor is being employed to undertake these tasks it is important that the requirements are clearly stated in the contract along with when and how often the tasks need to be conducted.

It is normal for an O&M contractor to provide a warranty guaranteeing the availability of the PV plant. In some cases when the O&M contractor is also the EPC contractor, it is possible for the warranty to include targets for the PR or energy yield. The agreed availability limits are often based on the independently verified energy yield report, but with some leeway.

In general, the O&M activities for a solar PV power plant are less demanding than those related to other forms of electricity generation. This is mainly due to the fact that there are no moving parts in a solar PV system (unless it is a tracking system). However, maintenance is still an important factor in maximising both the performance and lifetime of the plant components.

12. ECONOMICS AND FINANCIAL MODEL

12.1 Economic Benefits and Costs

As well as providing commercial benefits to renewable energy project developers, solar PV projects confer many economic advantages to local and national economic growth.

Economic benefits and costs should be considered by policy makers, developers, investors and lenders to ensure that individual profitable projects develop within a framework of sustainable development.

Lenders often require compliance with social and environmental standards. Multilateral agencies such as the IFC may have their own Social and Environmental Performance Standards. Other lenders may require compliance to standards as outlined in the Equator Principles^[51] before agreeing to finance a project. Government bodies may aim to mitigate the adverse impact of developments through permitting requirements.

The Government of India has implemented an array of policies to enhance the growth of the solar market and support the National Action Plan for Climate Change (NAPCC)^[52].

The major economic benefits and drawbacks for large scale solar PV projects are outlined in the following sections.

12.1.1 Local Economic Benefits and Costs

In general, a solar project is likely to usher in economic benefits for the local area. But the level of benefit may be region-specific, and may vary across the country. An awareness of these local economic benefits will help developers and investors in pushing solar projects as a development tool for local communities and government agencies.

Local economic benefits may typically include the following:

- Generation of direct and indirect employment.
- Infrastructure developments such as roads, water and electricity.
- Development of barren, unproductive or contaminated land.
- Grid network upgrades providing power supply security.
- Less polluting power generation.

However, these benefits must be weighed against:

- **Resource impacts.** Many projects are likely to be constructed in areas with a scarcity of water and electricity. So the use of these resources during construction and operation of the plant may have an impact on the local economy. Careful siting and design of the projects should minimise this potential impact.
- **Demand management.** In urban India, peak demand normally occurs in the evening. Shortage of supply and inability to manage demand results in power cuts, which have a negative impact on the local economy and quality of life. While solar power is only generated during the day, there is no facility for trimming peak demand during the evening. Solar power development should, therefore, be part of a wider strategic plan to manage demand and supply.

[51] The Equator Principles (EPs) are a set of 10 environmental and social principles adopted by the Equator Principle Financing Institutions (EPFIs). These principles are criteria that must be met by projects seeking financing from these institutions. They are to ensure that the projects that receive finance are developed in a manner that is socially responsible and reflect sound environmental management practices. The full set of principles can be accessed through the following link: www.equator-principles.com/documents/Equator_Principles.pdf

[52] The NAPCC is the strategy by which the Government of India intends to meet the challenge of climate change. It was announced in June 2008.

12.1.2 National Economic Benefits and Costs

There are a number of national or macroeconomic benefits which are likely to accrue from the development of solar power generation within India. An awareness of these benefits will aid developers and investors when pitching the case for solar development to policy makers.

National economic benefits may typically include the following:

- Increased energy security arising from diversification from coal-fired generation.
- Long term energy price pressures mitigated due to diversification of generation mix and technology development. The cost of installing solar power generation is currently more expensive than coal-fired generation in India. This gap would be expected to reduce as the solar market matures and coal prices rise. Energy price stability can lead to a wide range of social and economic benefits. These include improved global competitiveness of domestically produced goods and services, inflation reduction and social cohesion.
- Reduced dependence on imports resulting from long term solar project development targets and mandates set by the National Solar Mission for consumption of domestically produced project components.
- Technology development, which leads to a redeployment of human resources from primary industrial activities to higher value-creating secondary industries.
- Climate change mitigation, in line with the NAPCC.
- Reduction in pollution externalities such as health and environmental consequences.
- Increased tax revenue.

These benefits must be weighed against the cost of upgrades to major transmission lines. Grid upgrades are likely if

significant levels of solar power are installed in areas with a weak transmission network.

Budget diversions may also be significant as higher government budget allocations for solar projects may divert resources from low income groups. Engagement of the developer with the local community (by supporting local employment, for example) would be one way to work out a mutually agreeable solution.

12.1.3 Benefits to Developers

Investment in solar projects offers a number of economic benefits to potential developers, the most important of which are outlined below:

- **Preferential tariff and guaranteed returns** – Solar projects in India receive a FiT for 25 years.
- **Concessional duties and tax breaks** – The Government of India has announced a concessional customs duty of 5% on imports, with an exemption on excise duty for some project components.
- **Meeting the renewable energy obligation** – Utilities and independent conventional power producers have been mandated by the State Electricity Regulatory Commissions (SERC) to purchase renewable energy under the Renewable Purchase Obligation (RPO). At present, the proportion of renewable energy to be purchased varies from 3% to 5% of the total generation across various SERCs. This is likely to increase to 15% by 2020.
- **Renewable Energy Certificate (REC)** – RECs are market-based instruments which give the developer the option to either sell power produced at the state specific average power pooled cost, or alternatively to trade RECs separately.
- Certified Emission Reduction (CER) revenue^[53].

[53] CER credits can be sold under the Clean Development Mechanism. See Section 12.3.6

- **Improvement in corporate image** – Investment in solar power projects allows developers to demonstrate their commitment to environmental concerns.
- **Business diversification** – Development of expertise and technical skills within the developer organisation, allowing diversification of income generation streams and access to a large emerging market.

12.2 Central Electricity Regulatory Commission (CERC) Cost Benchmarks

12.2.1 Capital Cost

In order to determine the level of the feed-in tariff, the Central Electricity Regulatory Commission (CERC) has

produced a benchmark capital cost of INR 169 million/MWp for solar PV power projects commissioned during fiscal years 2010-11 and 2011-12. This capital cost is considered to be a reference cost in India as no large utility scale projects have yet been commissioned.

Figure 26 gives the percentage breakdown of cost for a typical 1MWp size project. These costs are discussed in more detail in Table 15. It should be noted that the various elements of the capital cost will vary depending on the technology selected and other project specific parameters; as an example, while the CERC benchmark costs show modules accounting for approximately 60% of the overall capital cost, it is not unusual to see module costs ranging from 50% to 60% of the overall cost.

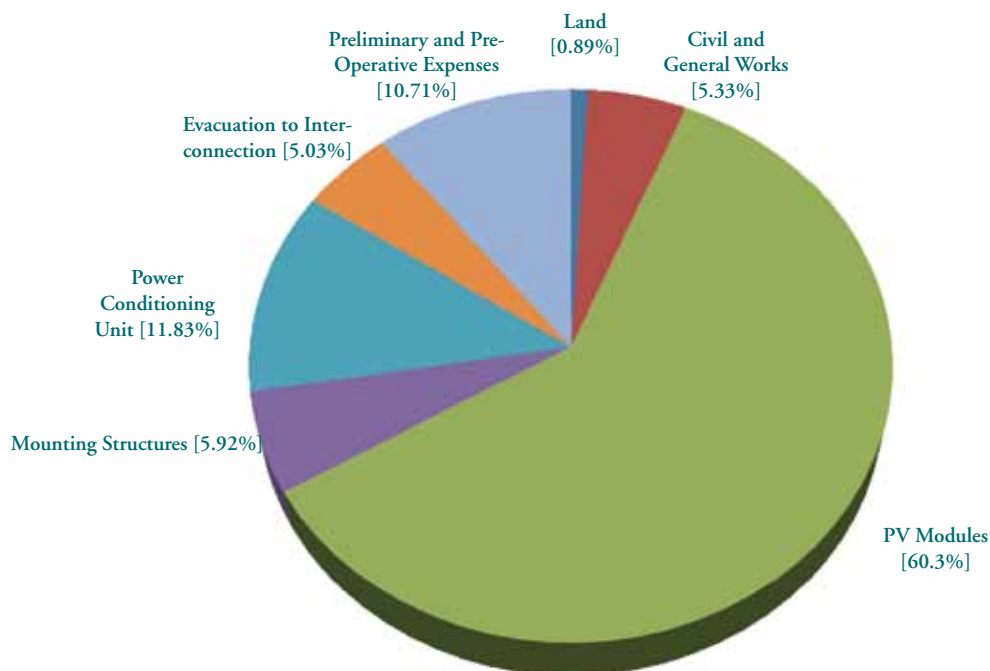

Figure 26: Benchmark Solar PV Plant Cost Breakdown according to CERC^[54]

[54] Central Electricity Regulatory Commission (CERC)(2009); RE Tariff Regulations Report

12.2.2 Tariff Structure

For projects commissioned in financial years 2010-11 and 2011-12, the tariff has been structured (assuming a useful life of 25 years) at a levelised rate of INR 17.91/kWh. This tariff takes into account a reasonable return of equity, interest on loan capital, depreciation factor, interest on working capital and O&M costs.

A more detailed discussion of the tariff structure is provided in Section 12.3.

12.2.3 Operations and Maintenance

O&M expenses comprising extended warranties, repairs, routine maintenance, employee and administrative costs have

been assumed to be INR 0.951 million/MWp for projects commissioned in fiscal year 2010–11. There shall be an annual escalation of 5.72% over the tariff period.

A more detailed discussion of the O&M costs associated with solar PV is provided in Section 12.3.

12.3 Financial Model

12.3.1 Introduction

It is clear from the discussion in the previous section that many of the economic benefits and costs of solar PV project development do not accrue directly to the developer.

Table 15: Benchmark costs

Cost item	Cost (INR million/MWp)	Details
Land	1.5	It is assumed that 5 acres/MW is required, at a cost of INR 0.3 million/acre, although this estimate will vary according to the technology chosen.
PV Modules	101.9	Although in practice there is a cost difference between crystalline and thin film PV modules, the cost assumed for both of these technologies is US\$ 2.2/Wp. An exchange rate of INR 46.33/US\$ is assumed.
Mounting structure	10.0	The cost assumed for the mounting structure is INR 10 million/MWp irrespective of the type of technology.
Power conditioning unit/inverters	20.0	The cost assumed for the power conditioning unit/inverters, including the required controls and instrumentation, is INR 20 million/MWp
Evacuation to grid connection	8.5	This cost includes supply, erection and commissioning of all cabling, transformers and evacuation infrastructure up to the grid connection point.
Preliminary and operating expenses	18.1	This cost includes services related to design, project management, insurance and interest during construction, among others. Though it is expected to vary with project size, the cost assumed for generic tariff determination is INR 18.1 million/MWp.
Civil and general works	9.0	This includes general infrastructure development, application for permits and approvals, and preparation of project reports
TOTAL	169.0	

Instead, these act as “externalities”, which stem from investment choices made largely on the basis of financial benefits and drawbacks.

The financial benefits and drawbacks to the developer are explored in detail through the construction of a full financial model. This facilitates the identification of key variables affecting the project value and enables financing decisions.

The following sections describe the key items and assumptions that would be included in the financial modelling of a typical Indian solar project, and discuss the conclusions that can be drawn from the results of the modelling process.

12.3.2 Capital Costs

According to a CERC report, capital cost per MWp for solar PV plant in India is expected to vary between INR 150 million to INR 170 million. This total capital cost includes the cost of land, PV modules, mounting structure, inverters, balance of plant and support infrastructure, and start-up costs. The cost variation largely depends on the project location, the project design (such as the voltage level of power cables), the technology utilised and the grid connection cost.

In addition to overall project cost, there can be significant variation in component costs depending on the type of PV technology used.

A project with crystalline PV technology requires less surface area per kWp installed compared to thin film modules. As a result, the mounting structure and DC cabling costs are lower. However, there is not significant variation in the other cost components.

12.3.3 Operations And Maintenance (O&M) Cost

O&M costs for solar PV are significantly lower than other renewable energy technologies. O&M costs depend on many factors, including the project location and the surrounding

environment. For example, a site located in a dusty environment is likely to require frequent cleaning of modules.

It is difficult to predict the O&M cost over the latter part of the 25 year design life as there are very few large scale solar projects that have been generating for sufficient time to have reached the end of their design life. The modules, which typically comprise over 60% of the total project cost, are generally supplied with performance guarantees for 25 years. However, other project components require routine maintenance and component replacement. Aside from O&M, operational expenditure will include comprehensive insurance, administration costs, salaries and labour wages.

12.3.4 Annual Energy Yield

There are a number of factors which affect the annual energy yield of a solar PV project as discussed in Section 6. The confidence level of the yield forecast is important, as the annual energy yield directly affects the annual revenue.

12.3.5 Energy Price

Besides the power generated, the solar PV project revenue is dependent upon the power price. This may be fixed or variable according to the time of day or year, and must be clearly stipulated in the power purchase agreement.

Economic return has historically been the key limiting factor for development of large scale grid-connected solar PV projects. PV has a high initial capital cost. High energy prices are required for projects to be economic. Currently, grid-connected solar projects are highly dependent on policy support initiatives such as grants, feed-in tariffs, concessional project funding and mandatory purchase obligations.

In India, the power tariffs for solar PV projects are determined by the Ministry of New and Renewable Energy (MNRE). Incentive policies include the generation-based incentives (GBI) and the recently created Jawaharlal Nehru National Solar Mission (JNNSM).

Under these regulatory regimes and incentive schemes, there are five main tariff options for the sale of the renewable power that is generated:

- Demonstration scheme GBI – tariffs aimed at supporting pilot projects.
- JNNSM scheme – tariffs to encourage both large and small scale projects.
- CERCs Levelised Tariff – generalised country wide tariff.
- State Government Incentives – localised tariffs.
- Selling electricity and trading RECs separately.

Under the GBI scheme, the project developer signs a PPA with the relevant state utility grid operator for a period of 10 years, whereas under the JNNSM scheme, PPAs will be signed for 25 years.

CERC has ruled that projects commissioned in financial year 2010-2011 and 2011-2012 shall have a tariff term of 25 years. This term has been fixed on the basis of a reasonable deemed internal rate of return (IRR). Equity is assumed to comprise 20% of project cost, with a rate of return of 19% for the first 10 years of operation, and 24% for the rest of a plant's useful life.

Under the JNNSM scheme, large scale solar projects with an installed capacity of 5MWp and above—connected to the grid at 33kV and above—will sign a PPA with NVVN. This, in turn, shall bundle the power with conventional power and sell it to various utilities through the RPO. For projects with an installed capacity of less than 5MWp, connecting to the grid at less than 33kV, the project developer will sign a PPA with the state utilities.

Trading of RECs must be conducted through power exchanges within the price-range set by CERC. This range is subject to variation. Given the variability of the price of RECs, this policy involves a higher level of risk for developers than

fixed rate tariffs. However, it has potential for better revenue than some of the other options.

All projects should carefully assess the current tariffs available to them to capitalise on the best rate. It is advisable to reassess the rate at any stage when the tariffs vary or new options (for which the plant would be eligible) become available.

12.3.6 Certified Emission Reductions (CERs)

As India is a non-Annex 1 party under the UN Clean Development Mechanism (CDM), qualifying Indian solar projects could generate Certified Emission Reductions (CERs). These CERs can then be sold to Annex 1 parties and help them comply with their emission reduction targets. This effectively causes transference of wealth from Annex 1 parties such as the UK and Germany to Indian developers.

Each CER is equivalent to the prevention of one tonne of carbon dioxide emissions. The income from CERs can be substantial. However, this revenue source cannot be predicted as it is uncertain whether the project will be accredited. Moreover, CER values fluctuate considerably. Therefore, sensitivity analysis around the CER price (and the period of time for which the project is accredited) is important.

The National CDM Authority under the Ministry of Environment and Forests (MoEF) is the designated authority in India for approving CDM projects.

12.3.7 Financing Assumptions

The project financing structure generally comprises of debt and equity as described in Section 13.

The general financial assumptions for a project in India are as follows:

- Financing structure – equity 20% and debt 80% as assumed in CERC tariff order.
- Debt repayment period – 10 years.

12.3.8 Project Economics and Financial Modelling Results

A project financial model will calculate a range of project value indicators in order to allow developers, lenders, investors and relevant government bodies to assess the project economics from several perspectives.

From an investor's point of view, a project is generally considered to be a reasonable investment only if the internal rate of return (IRR) is higher than the weighted average cost of capital (WACC). Investors will have access to capital at a range of costs; the return arising from investment of that capital must be sufficient to meet the costs of that capital. Moreover, the investment should generate a premium associated with the perceived risk levels of the project.

Solar projects are usually financed with equity and debt components. As a result, the IRR for the equity component can be calculated separately from the IRR for the project as a whole. The developer's decision to implement the project or not, will be based on the equity IRR.

As returns generated in the future are worth less than returns generated today, a discount can be applied to future cash flows to present them at their present value. The sum of discounted future cash flows is termed the net present value (NPV). Investors will seek a positive NPV, assessed using a discount rate that reflects the WACC and perceived risk levels of the project.

Lenders will be primarily concerned with the ability of the project to meet debt service requirements. This can be measured by means of the debt service coverage ratio (DSCR), which is the cash flow available to service debt divided by the debt service requirements. The Average DSCR represents the average debt serviceability of the project over the debt term. A higher DSCR results in a higher capacity of the project to service the debt. Minimum DSCR represents the minimum repayment ability of the project over the debt term.

A Minimum DSCR value of less than one indicates the project is unable to service the debt in at least one year. Lenders will conduct sensitivity analysis around the key variables in order to determine whether the project will be able to service the debt in a bad year, for example if energy yield is lower than expected, or operational expenditure is higher than expected.

12.3.9 Sensitivity Analysis

Sensitivity analysis involves changing the inputs in the financial model (such as power tariff, capital cost, and energy yield) to analyse how the value of the project changes (measured using Net Present Value, Internal Rate of Return, or the Debt Service Cover Ratio).

Sensitivity analysis gives lenders and investors a greater understanding of the effects of changes in inputs such as power tariffs on the project's profitability and bankability. It helps them understand the key risks associated with the project.

Typical results that are monitored during sensitivity analysis include:

- Post tax Project IRR.
- Post tax Equity IRR.
- Average DSCR.
- Minimum DSCR.

Typical variables investigated during sensitivity analysis are:

- Capital costs.
- Operational costs.
- Annual energy production.
- Interest rate.

Case Study 6

Economics and Finances

The 5MW plant's costs increased during the project development and implementation phase, but the escalation was only 2% of the original predicted cost. The risk of escalating cost was reduced by employing EPC contracts for the major site works. Projects developed using EPC contracts are able to reduce the risk of cost overruns. Detailed financial models, including sensitivity analysis should be carried out.

The plant was financed by a combination of equity and loan, including 18% of the final expected loan cost from the IFC. Cost estimates of the project were provided by the developer at different stages of development and construction. The first cost estimate was made in 2008/09; a final expected cost was calculated in late 2010. A comparison of the costs against CERC benchmark values has been made in the table below.

Cost Area	Cost (INR million/MW)			
	CERC benchmark	5MW plant		
		Original estimated cost (2008/09)	Cost at EPC contract signing	Final expected cost (Q4 2010)
PV Modules	101.9	110.0	115.0	115.0
BOS and transmission line	28.5	56.9	60.6	60.6
Civil, mechanical works and commissioning	19.0	15.0	13.3	13.3
Land	1.5	7.0	3.7	3.7
Pre operative expenditure		4.0	4.0	5.7
Interest	18.1	2.0	2.0	4.1
Financing fee		1.0	1.0	1.1
Contingency		3.9	0.2	0.0
Total Cost	169.0	199.8	199.8	203.5
% variation on benchmark		+18%	+18%	+20%

The comparison shows that the CERC benchmark provides reasonable indicative estimates but these must be adjusted according to project specific details. The main variation in the 5MW Tamil Nadu project compared to the CERC benchmark can be attributed to the cost of PV modules and electrical works. The price of PV modules was found to be 13% higher than the CERC benchmark and the cost of electrical works was 113% higher than the benchmark. The high cost of electrical works was partly due to the requirement for an electrical transmission line extension.

The benchmark land costs (0.3 INR per acre) provided by CERC were in line with land costs incurred during the project. However, the project used 13.2 acres of land per MW installed compared to the CERC benchmark of 5 acres. As a result, the cost of land per MW installed was more than double that of the CERC estimate.

In total, the Tamil Nadu project cost 20% more than the CERC benchmark. Although the costs increased during the project development and implementation phase, the escalation was only 2% of the original predicted cost. The risk of escalating cost was reduced by employing EPC contracts for the major site works.

The table below shows how the operating expenditure (estimated for the 5MW Tamil Nadu plant) compares to CERC benchmarked costs, including the expected yearly escalation rates. As the operating costs are only estimates at the time of writing, no lessons can be learnt at this stage. However, the indication is that the Tamil Nadu plant O&M cost estimates are in line with those of CERC.

Cost Area	5MW solar plant (INR)	CERC (INR)	% Difference
Supervisor Salaries	480,000	4,755,000	-6%
Labour Wages	2,437,500		
Insurances	782,500		
Office Expenses	400,000		
Spare Parts & Tools	400,000		
Total O&M Cost for 5MWp	4,500,000		
Annual Escalations	5.00%	5.72%	-14%

Project costs and energy yield predictions were incorporated into a financial model to assess the viability of the project with a tariff rate of INR 17.91/kWh. A sensitivity analysis was also conducted to determine the viability of the scheme under different stress tests.

Conclusions

- CERC benchmarks can be used to make reasonable estimates of project costs at the feasibility stage.
- Costs need to be adjusted according to the specifics of the project, such as the distance to the grid connection point.
- Predicted costs for the Tamil Nadu project have been adhered to as they fall within the 2% escalation range. Discrepancies with the CERC benchmarks were due to module cost, electrical connection costs and the total area of land required for the project.
- Projects developed using EPC contracts are able to reduce the risk of cost overruns.
- Detailed financial models, including sensitivity analysis should be carried out.

13. FINANCING PV PROJECTS

13.1 Introduction

The financing of solar PV projects is typically arranged by the developer or sponsor. It comprises two parts: an equity investment and project financing to cover the debt portion.

Project finance is the long term financing of infrastructure and industrial projects based upon the projected cash flows of the project rather than the balance sheets of the project sponsors. Both the equity partners and project finance partners typically conduct an evaluation of the project covering the legal aspects, permits, contracts (EPC and O&M), and technical issues prior to achieving financial closure.

The project evaluations (due diligence) identify the risks and methods of mitigating any risks prior to investment. Where the project has inherent risks, the exposure to these risks will be negotiated between the parties and reduced wherever possible with insurance.

The following sections cover each of these steps and processes.

13.2 Project Financing

13.2.1 Financing Alternatives

The equity portion can be provided by the developer or from equity partners that sign agreements or letters of intent to purchase the projects from the developers. Equity partners may be individual firms, developers or equity funds managed by management firms, bank equity fund managers or pension fund managers.

The equity funds can be used as the seed capital to start the construction of the project, following completion of the design and environmental studies, legal analysis, permit applications and grid connection applications. The equity is typically around 15-20% of the total project investment cost.

It is not unusual to see an equity financing fee involved in the provision of equity to the project. In some cases, the equity partner provides operations management for the project over the long term.

In Europe, it is quite normal to see equity partners and developers form a special purpose vehicle (SPV) to develop the project. This is the equity vehicle which owns the project and plant when constructed. The SPV signs the EPC and O&M contracts, and the project revenues are paid to the SPV. The working capital requirements and debt servicing are taken from the revenue to determine the returns for the equity partners from the projects, typically in the form of dividends.

In some cases, the equity partners will not commit equity to projects unless they have received firm commitments of debt project finance or leasing finance.

The debt portion is typically provided by an investment bank providing project finance or leasing finance. The debt portion is the larger investment, which is typically 80-85% of the total project cost.

Despite the recent turmoil in the international credit markets, many financial institutions are willing to provide long term finance for the solar energy market. Individual projects from smaller developers may receive financing with a loan to value (LTV) ratio of 80%, whereas portfolios of solar projects from experienced developers may be financed with a LTV ratio of 85%. The usual term of a project finance loan is approximately 18 years.

Large corporations and utilities may develop solar plants without the need for project finance; these projects are financed from the corporate balance sheet. But the corporation or utility will still conduct a similar due diligence review before committing the project funds.

13.2.2 How a Lender Evaluates a Project

Both equity and debt finance investors typically evaluate the legal, permitting, consent and technical due diligence areas of the project. The due diligence conducted at the equity stage may be based on preliminary technical information. On the other hand, the due diligence for project finance is conducted at a later stage and often supported with detailed technical information and designs.

The developer typically carries out the following tasks:

- Identifies the sites with the best resources.
- Negotiates the use of the land.
- Conducts an initial solar resource analysis.
- Completes an EIA.
- Conducts initial layout and design including initial equipment selection.
- Applies for and receives planning permits and consents.
- Applies for and receives grid connection offer or letters of intent.
- Applies for feed-in tariff (FiT) and/or PPA.

The equity investor typically evaluates the work in the list above. The next key step is to validate and confirm all the permits, consents and power purchase agreements. Along with the equity partner, the project SPV can look towards securing the technical solution, detailed design and equipment supply. In some cases, these are carried out by the developer, depending on the stage in which the equity partner enters the project.

The project finance partner can often influence the choice of the equipment technology, based on what they perceive to be “bankable”. This often affects the selection of modules, inverters or mounting structures. One way to avoid such issues is to have discussions early in the design phase with the project finance partner. This can help assess the equipment selection and satisfy the requirements of all partners.

The due diligence phase of evaluating a project takes three main forms:

- Legal due diligence – assessing the permits and contracts (EPC and O&M).
- Insurance due diligence – assessing the adequacy of the insurance policies and gaps in cover.
- Technical due diligence – assessing the technology, integration and technical aspects of the permits and contracts.

The due diligence process reviews the designs and equipment specifications against best industry practice and examines their appropriateness to the environment and design goals of the PV plant. Typical areas assessed in technical due diligence are:

- Sizing of the PV plant:
 - Layout in the land area available.
 - Appropriate buffer zone around the plant to account for shading/other activities.
 - Overall size appropriate for the grid connection.
- Layout of the PV modules, mounting and/or trackers, and inverters:
 - Assessment of level of inter-row shading.
 - Access to plant components for maintenance and installation activities.
- Electrical design layout and sizing:
 - Assessment of cable losses in the DC/AC cabling.
 - Assessment of appropriateness of the cable placement and connectors.
 - Appropriateness of the earthing and protection systems.
 - Compliance to safety standards.

- Technology review of major components (modules/ inverters/mounting or trackers):
 - Suitable for environment.
 - Integration of components.
 - Track record of suppliers and models.
 - Quality and compliance certificates.
 - Compliance to safety standards.
 - Warranties.
 - Design life.
 - Degradation assumptions.
- Energy yield assessments:
 - Appropriateness of any assumptions made.
 - Source of solar irradiation data.
 - Assessment of shade.
 - Degradation assumptions.
 - Uncertainty analysis.
 - Model used and modelling techniques.
 - Check the theoretical Performance Ratio.
- Contract assessments (EPC, O&M, grid connection, power purchase and FiT regulations):
 - Looking for interface points and areas where there could be risks.
 - Examining construction timelines and ensuring that the critical path is clearly identified and mitigated in the contracts.
 - Assessing the warranty and guarantee positions within the contracts – protection for the lenders.
- Financial model assumptions:
 - Assessing that the assumptions used are complete and appropriate.

The process of due diligence can require considerable effort from the developer to satisfy the requirements of the lenders. It is important that the developers have realistic financial models with contingencies clearly shown. Alongside, it is also imperative to have a sensible construction programme, which takes contingencies into account. Such a programme will clearly show that the target deadlines are realistic and achievable.

The due diligence process is likely to identify risks, and help develop solutions to mitigate the issues found. It may result in changes in the design or use of components in the plant to make the project “bankable” for the lenders.

13.3 Risks

This section describes the key risks considered to be applicable to an investment in solar PV projects. The list of risks identified below is not an exhaustive list. Investors and developers should satisfy themselves that the level of risk attached with any development is appropriate to their investment criteria. Developers and investors should make every effort to mitigate the risks where possible.

13.3.1 General Business Risks

13.3.1.1 Interest Rates

Interest rate risk (variability in rates) is the risk borne by an interest-bearing loan. It can be beneficial to finance projects on long term fixed interest rate loans, as opposed to variable rate loans.

A fixed rate loan is a long term loan that carries a predetermined interest rate with a tenure usually of 15-20 years. Ideally, the plant should pay back the loan in 10 to 12 years. But spreading the loan over a longer period allows for smaller annual payments. This allows the developer the scope to build a reserve and to return a profit in the first years.

The interest rate is payable at specified dates before maturity. This can be the best form of natural hedging to match long term income with long term sources of finance.

13.3.1.2 Leverage

In cases where projects are to be financed through a mixture of equity and non-recourse debt finance, leverage may potentially increase the total return of the equity investors. But it may also lead to increasing losses in adverse market conditions.

13.3.1.3 New Business Start-up

As the solar PV industry is fairly new, very few companies have a long history in operating in this renewable energy sector. A possible way to tackle this problem is to have key contractor and strategic partners that have experience in constructing and operating solar power plants.

13.3.2 Technical Risks

13.3.2.1 Solar Module

It is important to consider the quality of modules (for example, checking whether degradation will occur faster than expected) and the strength of the module manufacturer's warranties. Any problems in the installation are usually identified within the first year and corrected under EPC (construction) warranties. Later, problems can be rectified under manufacturer's warranties. But as far as possible, it is preferable to avoid any interruptions to production.

Given the long term nature of the project, choosing the right technology is essential in achieving consistent results and maximising power output over the life of the project. A productive and viable PV power plant will automatically become an attractive proposition to potential buyers in the future.

13.3.2.2 Inverters and Cabling

Besides considering quality and warranties, the overall configuration of the PV power plant must be designed correctly. This will ensure that the maximum power reaches the grid based on the gross irradiance reaching the modules.

The technology and manufacturer choice for the inverters is also important for ensuring trouble-free operation suited to the environment and design of the PV plant. Warranties and maintenance activities for the inverters need to be carefully assessed to ensure that the risk of inverter failure is minimised.

13.3.2.3 Technology Failure

Generation of electricity involves mechanical and electronic processes. These may fail under certain conditions, leading to loss of revenue and repair or replacement costs. Selection of modules, tracking systems (if used) and inverters should be based on the track record of manufacturers—and the warranties they offer. These warranties help reduce the risk of technology failure in the initial years of the PV plant's operational life.

13.3.2.4 Solar Irradiation Risk

One of the key factors in determining the energy yield of a solar plant is the solar irradiation at the site. Changes in weather patterns such as cloud cover, rainfall and heat waves could reduce the energy output and, consequently, investor returns. However, meteorological assessments and long term averaging show that inter-annual variation over the lifetime of a PV plant is generally quite low, generally in the order of 5%, depending on location.

13.3.2.5 Solar Module Degradation

The efficiency of solar modules as well as their degradation (loss of performance) has a direct effect on the yield of a solar plant. The degradation is indicated by the supplier (usually less than 1% per year). Any unexpected loss of performance could have an adverse effect on the business.

Module manufacturer's power warranties generally cover larger losses of power due to degradation. However, the warranties need to be reviewed carefully for exclusions. The financial strength and backing of the module manufacturers should be assessed to verify that the manufacturer can support any claims against their warranties. In some cases, insurance policies may be taken out by the manufacturers to cover warranty claims.

13.3.3 Pre Completion Risks

13.3.3.1 Cost Overrun

Exposure to changes in the prices of components can account for a cost overrun. A change in prices for certain key components, in particular modules and inverters, may have an adverse effect on the bottom line.

13.3.3.2 Delay in Completion

Delay in completion occurs when there is a reliance on third party contractors for installation. In the construction phase of a project, developers and SPVs enter into agreements with third-party professionals, independent contractors and other companies to provide the required construction and installation services. If such contracted parties are not able to fulfil their contractual obligations, the developers may be forced to provide additional resources or engage other companies to complete the work. Any financial difficulty, breach of contract or delay in services by these third-party professionals and independent contractors could have an adverse effect on the business.

13.3.3.3 Permits, Grid Applications and Feed-in Tariff

Permits and grid applications need to be secured for all project sites. Any project will carry the risk that all approvals will not be finalised and approved by the competent authority or party within the expected timeline. Any delays may have an effect on the income stream from the corresponding project.

13.3.3.4 Grid Connection

The connection to the third party distribution or transmission network is often non-contestable. Therefore, the final grid connection is reliant on the works of the third party network operator or their contractor. Grid connection contracts and deadlines should be finalised to mitigate this risk.

13.3.3.5 Delay in Obtaining an Operating Permit

In some jurisdictions, the relevant authorities must determine whether the construction of the plant and connection facilities has been carried out in conformity with the approved design, and whether they comply with the legal requirements. Delays or difficulties in obtaining the operating permit may affect the income and profitability of the solar PV plant.

13.3.4 Post Completion Risks

13.3.4.1 Market Risk

Every developer should also keep in mind that government policy towards renewable energy may change unfavourably. Changes with respect to legislation concerning renewable energy policy could reduce the forecast revenues and profits of new projects. As importantly, a global consensus on taking action on climate change may positively influence government policy.

13.3.4.2 Change of Legislation

Legislation gives qualifying PV power plants the right to receive a levelised tariff which takes into account depreciation benefit. In India, under the JNNSM this tariff is guaranteed for all electricity produced for 25 years. Under Indian law, the government cannot retrospectively change the tariff issued. However, once a project is connected, particularly those under 33kV, there may be a residual risk that individual state governments may ask grid operators to retrospectively adjust the tariff levels.

13.3.4.3 Operational Considerations

Every operational solar power station engages an O&M Contractor to carry out the day-to-day maintenance of the solar power station. Inefficiencies in the operation and management of the project could reduce the energy output. This can be reduced by adding performance clauses within the O&M contract, based on the availability of the PV plant and targets for energy yield or performance ratio.

13.4 Insurance

13.4.1 Introduction

At present, the insurance industry has not standardised the insurance products for PV projects or components. A number of insurers are providing PV insurance policies, but underwriters' risk models have not been standardised. The data required for the development of fair and comprehensive insurance policies are lacking as insurance companies often have little or no experience with solar projects.

However, demand for PV insurance is increasing. In general, large PV systems require liability and property insurance, and many developers may also opt to add policies such as environmental risk insurance.

Though PV insurance costs can be quite high, it is likely that rates will drop as insurers become familiar with PV plants and as installed capacity increases. A recent study by NREL stated:

“Insurance premiums make up approximately 25% of a PV system's annual operating expense. Annual insurance premiums typically range from 0.25% to 0.5% of the total installed cost of a project, depending on the geographic location of the installation. PV developers report that insurance costs comprise 5% to 10% of the total cost of energy from their installations, a significant sum for a capital-intensive technology with no moving parts.”

It is important to note that insurance is no substitute for quality (design and components), and should not be seen as a ‘magic wand’ to mitigate issues related to design, equipment or contract.

13.4.2 General Liability Insurance

General liability insurance covers policyholders for death or injury to persons or damage to property owned by third parties. General liability coverage is especially important for solar system installers, as the risk to personnel or property is at its greatest during installation.

13.4.3 Property Risk Insurance

The PV system owner usually purchases property insurance to protect against risks not covered by the warranty or to extend the coverage period. The property risk insurance often includes theft and catastrophic risks.

Property insurance typically covers PV system components beyond the terms of the manufacturer's warranty. For example, if a PV module fails due to factors covered by the warranty, the manufacturer is responsible for replacing it, not the insurer. However, if the module fails for a reason not accounted for in the warranty, or if the failure occurs after the warranty period, the insurer must provide compensation for the replacement of the PV module.

13.4.4 Environmental Risk Insurance

Environmental damage coverage indemnifies PV system owners against the risk of either environmental damage inflicted by their development or pre-existing damage on the development site.

13.4.5 Business Interruption Insurance

Insurance against the risk of business interruption is often required to protect the cash flow of the solar project. This insurance policy can often be a requirement of the financing process.

14. CONCLUSION

It is widely being accepted that solar energy has a major part to play in promoting ecologically sustainable growth and tackling climate change. In addition, tapping the power of the sun can improve the energy security of those countries, including India, which are currently dependent on fossil fuel imports.

India has excellent reserves of solar resource and is well-placed to benefit from the development of a solar energy industry. However, there are numerous and varied challenges to be overcome at various levels in order to establish a successful solar power industry.

It is vitally important that developers and financiers of solar energy projects follow best practices in developing, constructing, operating and financing projects. It is hoped that this guidebook will go some way towards promoting such best practices in the sector. However, it should be borne in mind that there is no substitute for experience and expertise.

Appendix A

Concentrated Solar Power: A Guide For Developers and Investors

1. INTRODUCTION

The objective of this report is to provide an overview of Concentrated Solar Power (CSP) technology. The report is intended to be read in conjunction with “Utility Scale Solar Power Plants: A Guide for Developers and Investors”, and focuses on those areas where CSP differs from PV. The report describes the following technologies and associated aspects of CSP projects:

Technologies:

- Concentrated solar power technologies including:
 - Parabolic Trough.
 - Power Tower / Central Receiver.
 - Parabolic Dish / Stirling Engine Systems.
 - Linear Fresnel Reflectors.
- Integrated Solar Combined Cycle (ISCC).
- Concentrating Photovoltaics (CPV).

Project aspects:

- Solar resource.
- CSP technologies uptake, experience and costs.
- Solar field equipment and heat transfer.
- Energy storage and supplementary heating.
- Power block / steam plant.
- Cooling and water consumption.
- Site selection.
- Energy yield prediction.
- Project implementation including design, development and construction.
- Uncertainties and risks.

2. INSTALLED CSP CAPACITY

Between 1984 and 1990, 354 MW of CSP generating capacity was commissioned. This capacity remains in operation today. No additional commercial plants were commissioned until 2007^[1]. The suspension of commercial CSP from 1990 to 2007 was primarily caused by the high cost of the technology in comparison with overall wholesale power costs.

The renewed market interest in CSP since 2007 is due to a combination of rising fossil fuel costs, firm renewable energy targets, and substantial governmental subsidies or other financial support mechanisms. These factors have helped CSP technology become commercially attractive, resulting in increased investment in CSP projects. There is now 900 MW of total capacity commissioned and a further 1,900 MW under construction.

When bundled with energy storage or when integrated with biomass or fossil-fuelled power plants, CSP can provide load-matching generating capability. Hence, CSP is being considered as a major part of the renewable energy mix in the long term^[2]. However, this will be dependent on substantial cost reductions being achieved, combined with government-driven economic support.

3. THE SOLAR RESOURCE

CSP technology generates electricity by focussing the component of solar irradiance that travels directly from the sun. The diffuse component of solar irradiance which is scattered from the ground and the sky cannot be focussed and therefore cannot be used by CSP technology. For this reason, a CSP plant must be located in an area where clear skies are common, as any cloud cover, haze, fog or smog would significantly reduce the levels of direct irradiance reaching the plant. To focus the direct irradiance, CSP technologies should face the sun at all times. They do this by using sun tracking technology.

[1] SgurrEnergy CSP project database collated from information in Photon International, Sun & Wind Energy [particularly 6/2010 issue], NREL CSP projects database [http://www.nrel.gov/csp/solarpaces/by_project.cfm], and developer or project websites.

The distribution of average daily direct normal irradiation across India is shown in Figure 1. High resource locations are represented in red and orange. Plants located in these regions will have a superior financial viability. From Figure 1 it can be seen that the most suitable locations are primarily in desert regions such as those in western India.

Financial viability of projects will depend upon the resource, technology and project costs, and the extent of government-driven financial support. Current costs of the technology and constraints on financial support indicate that only projects that are located in the areas with the highest direct normal irradiation are likely to be viable in the near future with annual average direct normal irradiation values of greater than 2.2 MWh/m²/year or 6.0 kWh/m²/day^[4].

4. REVIEW OF CSP TECHNOLOGIES

CSP technology utilises solar power by first concentrating low density solar radiation and then either converting it:

- To heat energy, and then through a turbine and generator to electricity, in concentrating solar thermal systems; or
- Directly to electricity, in concentrating photovoltaic (CPV) systems.

The main concentrating solar thermal technologies are reviewed in Sections 4.1 to 4.4, while the related Balance of Plant (BoP), heat transfer media, factors affecting project development and location, and the potential for integration with conventional thermal generating plant are evaluated in Sections 4.5 to 4.8. CPV systems are reviewed in Section 4.9. Linear Fresnel reflectors are covered in section 4.10.

[2] IEA; Technology Roadmap, Concentrating Solar Power; 2010

[3] National Renewable Energy Laboratory <http://nrel.com>

[4] SgurrEnergy for Asian Development Bank; Central-West Asian Countries Solar Potential, Concentrated Solar Power; Draft report, November 2010.

India Solar Resource

Direct Normal Solar Resource

This map depicts model estimates of annual average direct normal irradiance (DNI) at 10 km resolution based on hourly estimates of radiation over 7 years (2002-2008). The inputs are visible imagery from geostationary satellites, aerosol optical depth, water vapor, and ozone.

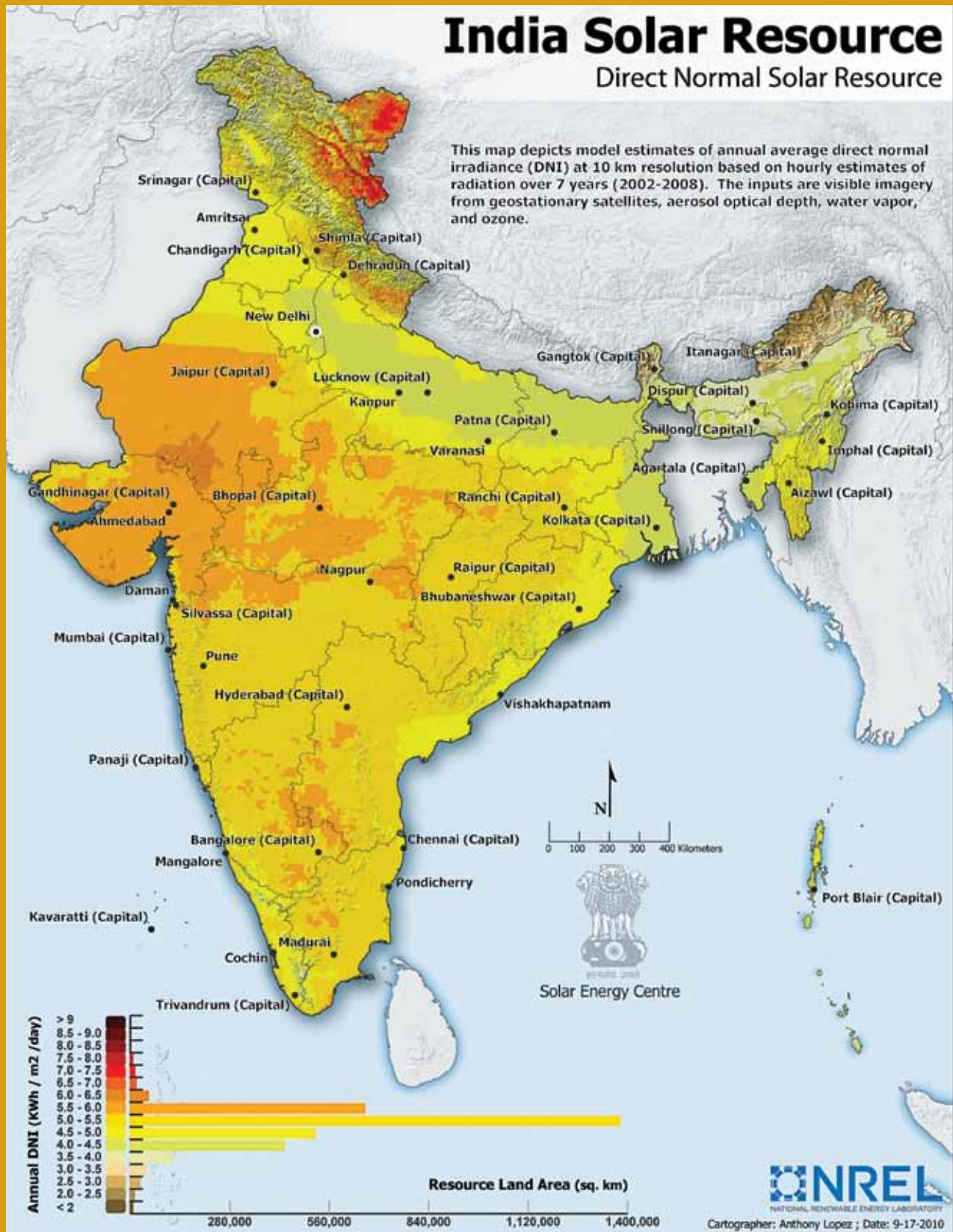

Figure 1: Average Daily Direct Normal Solar Irradiation in India (kWh/m²/day)^[3]

This diagram was created by the National Renewable Energy Laboratory for the Department of Energy (USA)

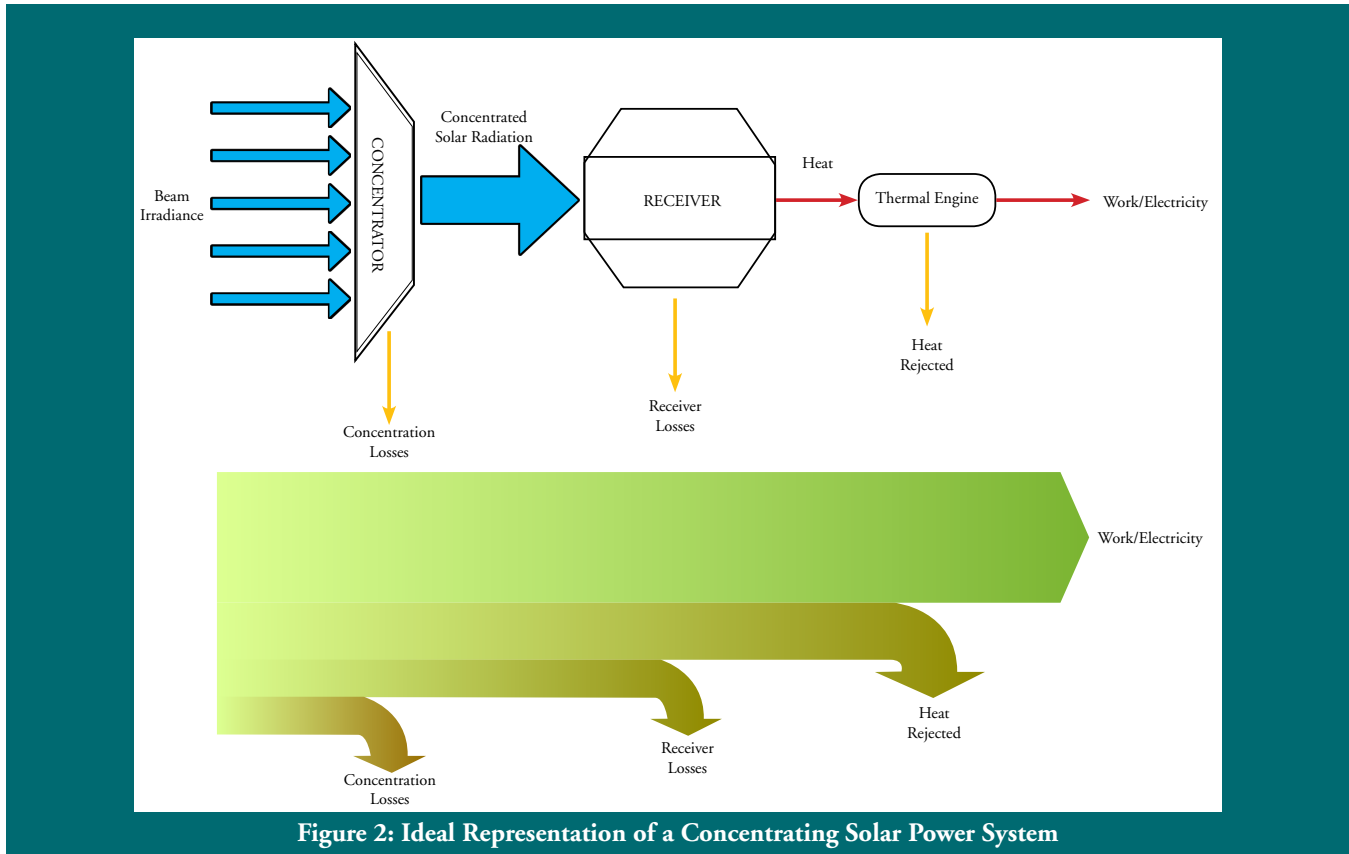

Figure 2: Ideal Representation of a Concentrating Solar Power System

4.1 Overview of Concentrating Solar Thermal Technologies

In concentrating solar thermal technology, the concentrator focuses the solar radiation on to a receiver which then heats a transfer fluid either directly or through a heat exchanger system. The heat transfer fluid is then passed into a conventional thermal generation plant. Figure 2 provides a schematic energy flow diagram (Sankey diagram) of a simplified concentrating solar thermal power system.

Concentrating solar thermal technologies include:

- Parabolic troughs;
- Power tower / central receivers;
- Parabolic dish / Stirling engine systems; and
- Linear Fresnel reflectors.

These may be categorised as line and point concentrators as shown in Figure 3.

Each of these technologies will be reviewed in greater detail in subsequent sections.

The overall arrangement for a typical utility-scale power plant using a parabolic trough solar field is shown in Figure 4. This example includes thermal energy storage, which is incorporated between the solar heat receiver and the electrical power generation plant. With parabolic trough collectors the receivers are distributed across the solar field in the reflector units, whereas in power towers the heat receiver is located at one or more centrally located towers.

Parabolic dishes can be used with a Stirling engine or alternatively a Rankine cycle heat engine, integral to

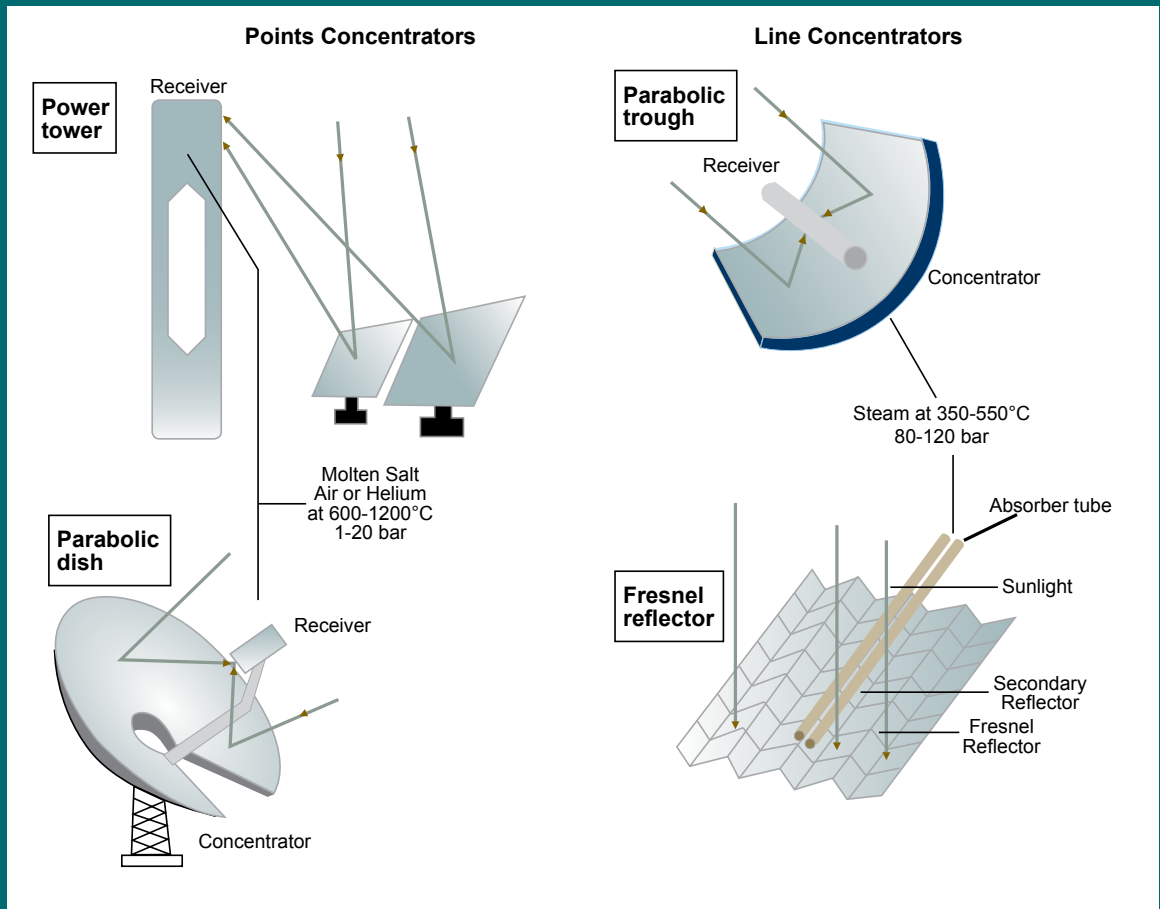

Figure 3: Solar Thermal Concentrator Types^[5]

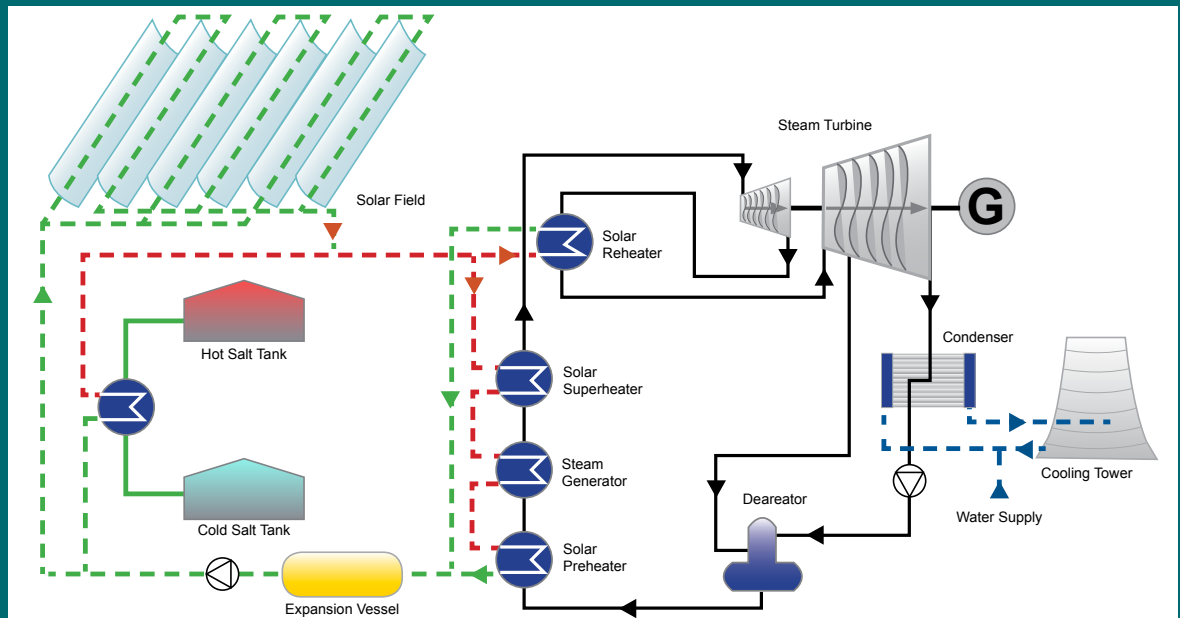

Figure 4: Typical CSP Power Plant Schematic (Parabolic Trough with Storage)^[6]

[5] Graphic courtesy of Abengoa Solar
 [6] Graphic courtesy of Abengoa Solar.

each dish unit. Utility scale parabolic dish power plants would therefore comprise many dish units. Energy storage is not included in such plants since the heat engine operates directly from the solar concentrator heat source.

The arrangement of linear Fresnel reflectors and power plant could be similar to that for parabolic troughs. However, since current linear Fresnel reflector installations yield lower temperatures than parabolic troughs, and hence lower efficiency conversion to electrical power, linear Fresnel technology is generally used for direct heat applications rather than utility power generation.

4.1.1 Uptake and Track Record

The uptake and track record of concentrating solar thermal technologies is shown in Table 1 and Figure 5^[7].

Parabolic trough technology is by far the most established technology in terms of operating experience. It also shows the highest anticipated build rate, taking into account projects which have reached the advanced planning stage^[8].

Geographically, south-west USA dominates in terms of operating experience and future projects, with Spain dominant in projects recently completed and under construction.

4.1.2 CSP Cost Trends

Due to variations in the configuration of the CSP plant (as described later in this guide), generating cost or levelised cost of electricity (US\$/MWh) is a much better indicator of true costs than installed cost (US\$/MW installed capacity). The capacity factor (or load factor) varies over a wide range for CSP plants. Plants with similar areas of solar field, and annual energy yields, may have differently sized generators depending on whether or not they have energy storage.

Generating costs have been calculated from available cost and performance information for recently completed projects and projects under construction. This information is shown in Figure 6^[9] (as a comparison the levelised cost of generation for PV plants in 2010 was estimated to range from

[7] Project data in the ScurrEnergy CSP database is collated from information in Photon International, Sun & Wind Energy [particularly 6/2010 issue], NREL CSP projects database http://www.nrel.gov/csp/solarpaces/by_project.cfm, and developer or project websites.

[8] Projects in the advanced planning stage are defined as projects where

development permits are in place or subject to final approval, power purchase agreements are in place and construction contracts and financing are at an advanced stage of negotiation.

[9] Calculated from selected project data in the ScurrEnergy CSP database assuming 8% discount rate.

Table 1: CSP Installed Capacity (MW)

Region	Advanced Planning	Construction	Operation	Notes
USA	7,837	758	431	Solar generation supplies peak air conditioning loads. To date, most plants without storage. 30% government support on capital cost, Department of Energy loan guarantees, renewables tariffs.
Spain	1,801	973	432	Individual plant capacity limited to 50 MW and storage encouraged by feed-in tariff mechanism (€269/MWh ~ US\$365/MWh).
Rest of World	276	165	9	Mainly ISCC in Middle East and North Africa (MENA)
Total	9,914	1,896	872	

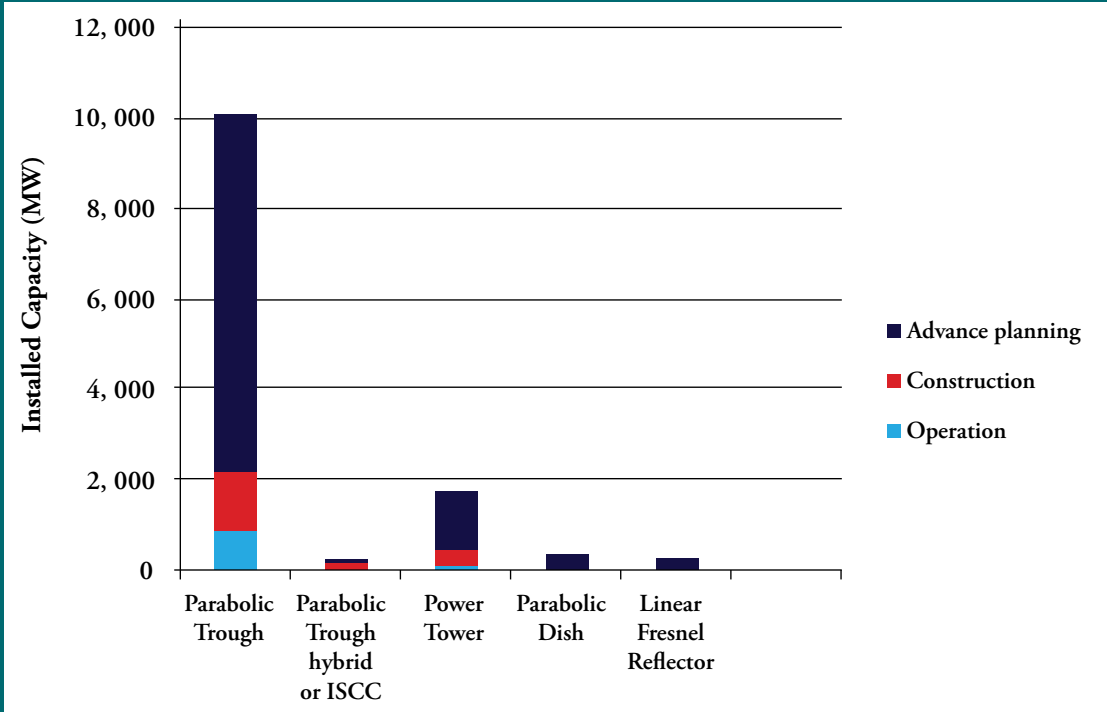

Figure 5: Implementation of CSP Technologies

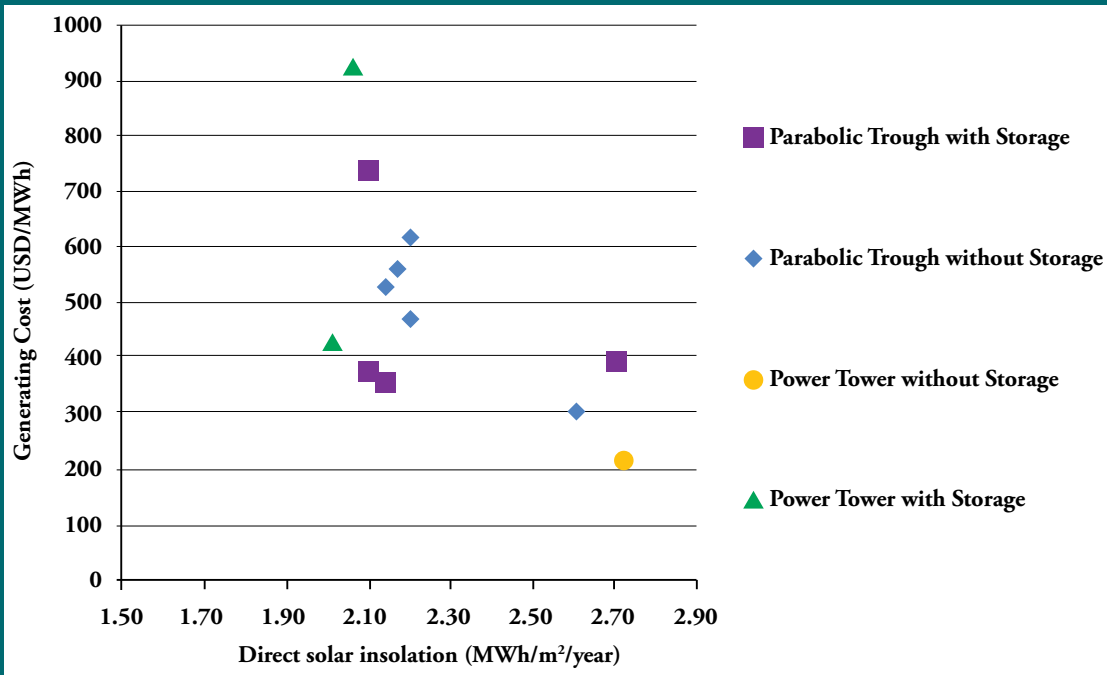

Figure 6: Generating Cost for Recently Completed and Under Construction CSP Projects

170 US\$/MWh (Middle East) to 400 US\$/MWh (Northern Europe). While there is no clear trend, or differentiation between the various technologies, it is clear that the sites with the greatest solar resource achieved the lowest energy costs.

Consistent CSP cost trends have yet to emerge but the following general comments can be made:

- Reported costs vary widely:
 - Projects which have recently been completed, or are currently under construction, show increasing cost trends; and
 - Previously projected cost reductions are currently not being realised.
- Generating costs will depend on:
 - Direct normal irradiation (DNI) at the project location;
 - Size of plant;
 - Optimization of the plant design;
 - Technology costs;
 - Cost reductions achieved through technology improvements;
 - Increased competition in the supply chain; and
 - Learning rate effects.

Recent CSP development in Spain has been driven by the feed-in tariff which was €269/MWh (approximately US\$365/MWh at the time of writing) for the regulated tariff option, for years 2 to 25, linked to the average or reference electricity price, with a lower tariff thereafter. Elimination of feed-in tariff for year one has recently been introduced to reduce a government budget deficit or pass-through of costs

to energy consumers. However, the pool price option enables generators to sell electricity at the market price and receive a lower premium tariff (€254/MWh) linked to the average or reference electricity price. Once the additional incentive for participation in this option and the continuity supplement are considered, the total tariff can typically be of the order of €330/MWh (US\$440/MWh) dependent on pool power price. The terms for the feed-in tariff limit the capacity of CSP plants in Spain to 50 MW each, and encourage incorporation of energy storage.

Recent costs have been two to three (or more) times previous current estimated costs – these factors should arguably be applied to the future projected costs. For all CSP technologies in the foreseeable future, substantial economic support will be required for project economic viability, through a support mechanism which is specifically designed to support CSP projects.

4.1.3 Summary Comparison

The key parameters of CSP technologies including CPV are summarised in Table 2.

4.2 Parabolic Trough Concentrators

A parabolic trough system is composed of a solar field, a power block and an optional thermal storage system. The solar field consists of parallel rows of parabolic, trough-shaped solar collectors that focus direct normal solar radiation onto tubular receivers located at the focal point of the collectors. The collectors are installed on single-axis tracking structures that can be aligned on a north-south or east-west horizontal axis depending on the electricity demand profile.

Each receiver consists of a metal tube with a solar radiation absorbing surface in a vacuum inside a coated glass tube. A heat transfer fluid is circulated through the receivers and transports the heat generated at the receivers to a series of heat exchangers in the power block of the plant. The temperatures achievable are generally in the region of 400°C. The heat is

used to generate steam which is fed into a conventional steam turbine to produce electricity.

Alternatively, parabolic troughs may be used for steam augmentation or to supply process heat.

Table 2: Comparison of Solar Thermal Concentrating Technologies^[10]

	Parabolic trough	Tower	Dish Engine	Linear Fresnel
Commercial experience	>20 years	<4 years	-	-
Technology risk	Low	Medium	High	Medium
Optimal scale/ modularity	50 MW to >100 MW	50 MW to >100 MW	100 kW to >100 MW	50 MW to >100 MW
Construction requirement	Demanding	Demanding	Moderate	Simple to Moderate
Operating temperature	300°C-550°C	260-570+°C	750°C	270°C
Efficiency	14-16%	15-22%	24-31%	9-11%
Storage	Yes	Yes	No	Yes
Levelised cost of energy (\$/kWh) ^[11]	Current: 0.30-0.75 Future: 0.06-0.08	Current: 0.20-0.90 Future: 0.06-0.08	Future: 0.05-0.08	Future: 0.06-0.08
Water usage	High	High	Low	Medium
Land requirement	High	High	Variable / flexible	Variable
Leading developers	Acciona Solar, Abengoa Solar / Abener, Solar Millenium, Solel / Siemens	Abengoa Solar / Abener, Bright Source Energy, Torresol, eSolar	Tessera Solar / Stirling Energy Systems (SES)	Ausra / Areva (small scale projects), Novatec Solar

[10] Original reference source: Technology Innovation Report, Concentrated Solar Thermal, Cleantech Group, 2008; DLR; SCB research. Taken from Standard Chartered Bank presentation and updated by SgurrEnergy.

[11] Cost ranges cover projects with and without storage where appropriate.



Figure 7: An Example of a Parabolic Trough Concentrator

Examples of a parabolic trough collector and a parabolic trough collector solar field are shown in Figure 7 and Figure 8.

The main elements of the collector system are:

- Reflector
- Receiver tube
- Heat transfer fluid
- Base frame
- Tracking system
- Connecting elements
- Control system

A brief description of each component is given in the following sub-sections.

4.2.1 Reflector

The reflectors used in parabolic trough systems are shaped mirrors which are curved to create a focal point within a linear

array. Mirrors need to be highly reflective to avoid losses and durable to resist the harsh environments encountered in the desert. The majority of mirrors currently used are of glass type with a reflective backing. Mirrors can be manufactured from thick or thin glass; however, thick glass mirrors are currently the most commonly used.

Thick glass mirrors are typically constructed of 3-5mm thick tempered glass or float glass (glass made by floating molten glass on a bed of molten metal), which due to the high curvature required is normally pre-curved during construction. The mirrors are typically fixed directly on to the parabolic trough supporting structure.

The number of companies manufacturing thick glass mirrors is limited, with demand still outstripping supply. The majority of reflectors manufactured for the parabolic trough industry are produced by either Flabeg or Rioglass, both of which have historically manufactured glass for the automotive industry. Other manufacturers are beginning to enter the market; however, their experience in manufacturing reflectors is still limited.

Thin glass mirrors are constructed of a glass layer of around 0.8 mm. Due to the flexibility of the glass, these mirrors can be fixed directly to the supporting structure to provide the concentrator shape. The benefits of this type of mirror are the high reflectivity of the structure and lower cost in comparison to thick glass mirrors. One drawback of these mirrors is that they can be subject to corrosion if not correctly fixed to the supporting structure.

Research is currently taking place on alternative reflector films made from such materials as polymers and aluminium. However, these technologies are currently still at the development stage and have not yet entered serial production or proved their durability.

Despite differing concepts, most trough collectors have a similar design approach with individual collectors ranging from 5 to 6 metres in width and 12 to 13 metres in length.

4.2.2 Receiver Tube

Receiver tubes are mounted at the focal point of the parabolic mirrors and serve as the first step in transferring the captured heat from the solar field to the power generation block. Receiver tubes are made of a steel tube with a solar active surface treatment. The surface treatment maximises the absorption of solar radiation and minimises the emission of radiative losses by means of a selective coating. The steel tube is surrounded by a glass tube with an internal vacuum to protect the selective coating from the effects of the ambient environment. Due to the differing expansion properties of steel and glass an expansion bellows connecting the outer and inner tubes is required. This ensures the vacuum between the tubes is maintained.

There are only two main manufacturers of receiver tubes on the market: the Israeli company Solel, now owned by Siemens, and the German manufacturer Schott.



Figure 8: An Example of a Parabolic Concentrator Solar Plant

4.2.3 Heat Transfer Fluid

The heat transfer fluid normally used in parabolic trough plants is thermal mineral oil. The two main types are Caloria, which has a temperature rating up to 300°C and Therminol which has a temperature rating up to 400°C. Therminol is the more efficient of the two due to its ability to meet the demanding requirements of vapour phase systems and its superior heat transfer properties.

Alternative oils have been investigated such as Syltherm which is rated above 400°C therefore allowing more efficient heat transfer. This oil is, however, more expensive than the others and as such it is not widely used.

There must be a drying stage within the heat transfer loop to prevent condensation forming in the thermal oil at night. Direct steam generation technology is used in some plants, which eliminates the costs of specialised heat transfer fluid and the need for heat exchangers; however, efficiency and energy storage capacity is reduced. Further research is required in this field and pilot plants will need to be installed and generating to determine the feasibility of using this medium as the transfer fluid.

Research^[12], including commissioning of a pilot plant, is currently underway investigating the use of molten salts (a mixture of sodium and potassium nitrate) as a heat transfer fluid. Molten salts are also used for energy storage as described in Section 4.5. However, as the freezing point of these salts is typically above 200°C, a mechanism needs to be in place so that the molten salt does not freeze in any component of the system, including the pipe runs in the solar field from the receivers to the power island.

Other heat transfer fluids undergoing research include pressurised gases and Diphenyl.

4.2.4 Base Frame, Tracking System and Connecting Elements

A structure is required to support the concentrators and allow the mechanism to track the daily path of the sun as it moves across the sky. The plants commissioned in the 1980s used a supporting structure designed by Luz International. Since then, there have been several evolutions from the original design. One such structure is the Euro Trough torque box design.

The torque box is designed so that collector elements can be connected together on one drive resulting in the reduction of the total number of drives and interconnecting pipes. The overall reduction in components results in a reduction of cost and of the thermal losses in the system.

Throughout the day, the parabolic troughs are normally set on tracking mode by electric motors driving through gearboxes, or directly by hydraulic drives. Hydraulic drives, which provide mechanical energy to move the collector, are currently the most common tracking mechanism used.

Generally, the solar field comprises many collectors. Earlier, collector panels were connected to one another by flexible hosing, which facilitated movement between neighbouring

collectors besides helping rectify minor misalignment issues. Some problems were observed during operations and the flexible hosing was replaced with a ball joint. This eliminated the original problem. However, some concerns have been raised with regard to the ball joint at high temperatures. Further research is being performed in this area.

The orientation of the solar field can be along either a north-south axis or an east-west axis. A north-south axis is the norm to allow collectors to track the sun's azimuth over each day, hence maximising annual output. An east-west axis, in contrast, allows for seasonal adjustments for the sun's elevation and latitude, thus maximising mid-day output. Since adjustment is seasonal rather than daily, east-west axis systems could dispense with motorised and automated tracking systems. Usually, utility scale projects in or near the tropics employ north-south axis systems.

4.2.5 Examples from Industry

To date, parabolic trough technology is the most widely deployed of the concentrating solar power technologies. Between 1984 and 1990, nine parabolic trough CSP plants, comprising 354 MW of generation capacity, were installed in the Mojave Desert of California in the south-west of the United States. These pioneering plants were the SEGS plants of Luz International; they are still in operation today having produced more than 11,000 GWh of electricity.

The technology ceased to develop for a period of time and from 1990 until 2007 no further commercial scale developments were commissioned. From 2007 to date a further 464 MW of parabolic trough power plants have been commissioned, 400 MW of which was installed in Spain.

An example of a recently completed project is the 50 MW Solnova I project which is reported to have achieved significant construction and alignment (tracking) technology improvements. In addition 1,310 MW of capacity is currently under construction in Spain and the USA, with 7,960 MW at the advanced planning stage, mainly in south-west USA.

[12] Sandia National Laboratories - National Solar Thermal Test Facility

4.2.6 Losses

Losses within a parabolic trough plant arise from geometrical, optical and thermal factors. These losses, which are described below, have to be given serious consideration during the design and siting stages of the plant development process.

Spacing between collectors must be adequate to minimise shading losses, taking into account daily and seasonal variations in the sun’s path. As well as lateral spacing, losses in the effective collector length will also have to be taken into account in sizing the solar field.

Optical and thermal losses will be present within the receiver and will need to be accounted for when determining a plant’s overall energy production. Optical losses are associated with the reflectivity, transitivity, absorptivity (the fraction of incident radiation that is absorbed) and beam irradiance inception factor properties of the receivers, including thermal incidence angle.

Thermal losses and flow losses occur in the solar field between the receivers and the power island, which places an upper limit on the size of solar field which can supply each

power block efficiently, depending upon the heat transfer fluid used. Thermal losses mainly consist of convection and conduction losses to air and surrounding elements.

The maximum theoretical efficiency of a steam turbine plant (or any other heat engine) is limited by the Carnot Efficiency, defined as:

$$\eta_{Carnot} = \frac{t_{inlet\ steam} - t_{condenser\ outlet}}{t_{inlet\ steam}}$$

Where:

- η_{Carnot} = Carnot Efficiency, (%)
- $t_{inlet\ steam}$ = Temperature of steam at inlet to turbine (K)
- $t_{condenser\ outlet}$ = Temperature of water at outlet of condenser (K)

Actual efficiency will always be lower than the theoretical maximum. As the steam temperature in a concentrating solar plant is likely to be lower than in a conventional steam power plant, and condenser temperatures may also be higher, the achievable efficiency is correspondingly lower.

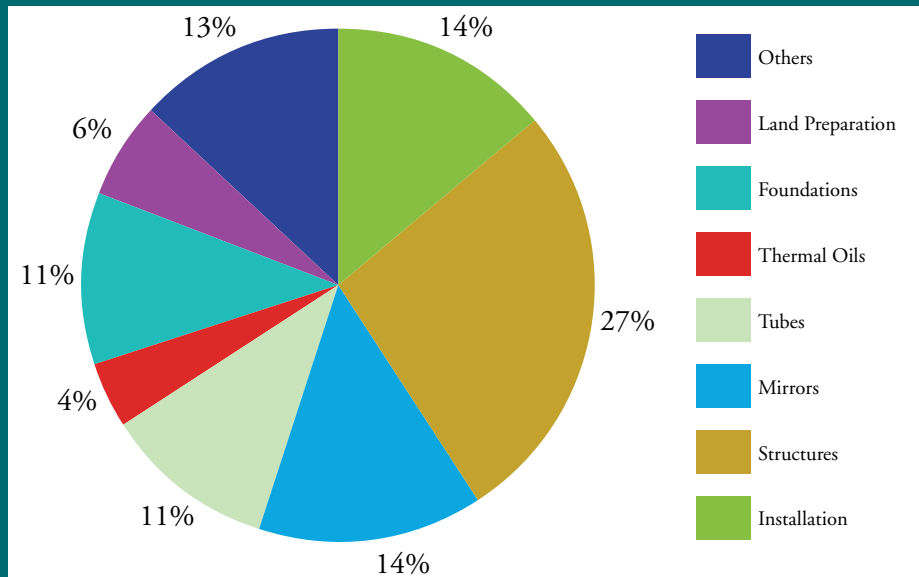

Figure 9: Component Cost as a Percentage of Overall Plant Cost^[13]

[[13] <http://www.leonardo-energy.org/csp-training-course-5-lessons>

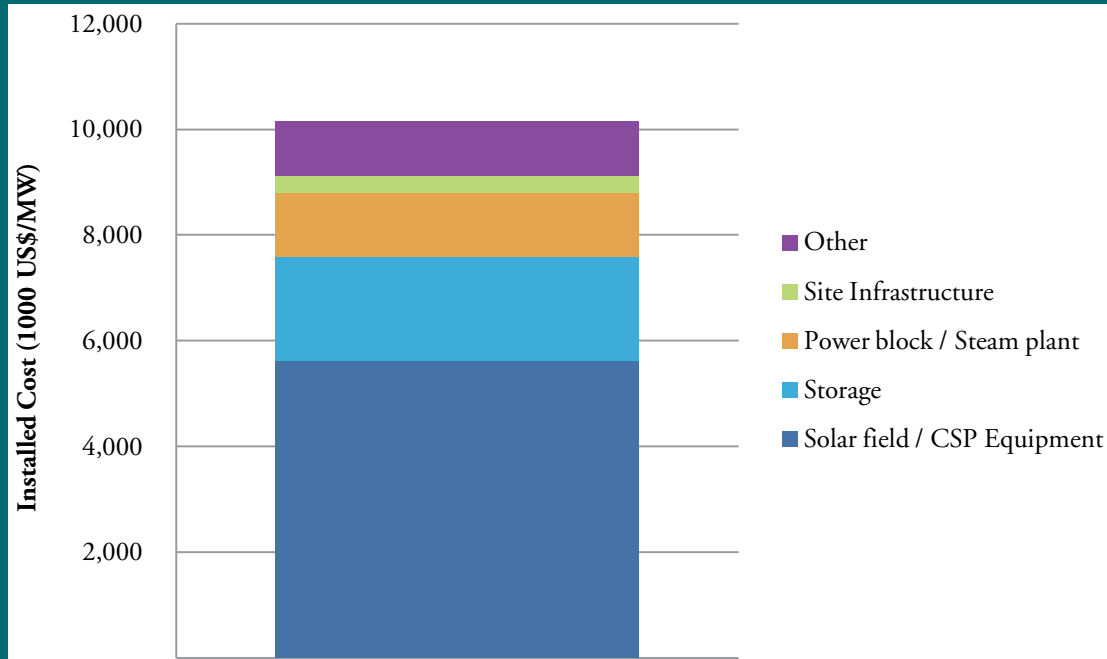

Figure 10: Installed Cost of a Parabolic Trough Plant with Storage

4.2.7 Costs

The following section explores the installed and generating cost of a reference Parabolic Trough plant.

Figure 9 provides a high level overview of the cost of each component in the solar field as a percentage of the overall cost of the parabolic trough concentrator system.

The solar field accounts for around 60% to 80% of the overall cost, while the power block (without energy storage) accounts for around 10% to 15%. Energy storage, where required, typically comprises 15% to 20% of the cost. The remaining cost is required for the civil and electrical site infrastructure and other development activities.

Figure 10 and Figure 11 give the installed cost and generating cost breakdowns for a 100 MW capacity reference plant, based on the NREL SAM reference plant^[14]. The reference plant characteristics and main assumptions used to calculate the generating cost are given in Table 3. Based

on these inputs, the levelised cost of energy was US\$377/MWh, with the largest component of this cost being capital repayment on the cost of the project.

The main opportunities for cost reduction have been reported as:

Item	
Installed capacity	100 MW
Direct normal irradiance (DNI)	2.4 MWh/m ² /yr
Land area	400 ha
Capacity factor / load factor	38%
Energy yield	333 GWh/yr
Energy yield per hectare	0.83 GWh/yr/ha
Capital repayment	8% discount rate, 20 year term

[14] NREL SAM model reference plant information from: Technical Report NREL/TP-550-47605, July 2010; Parabolic Trough Reference Plant for Cost Modelling with the Solar Advisor Model (SAM); C. Turchi.

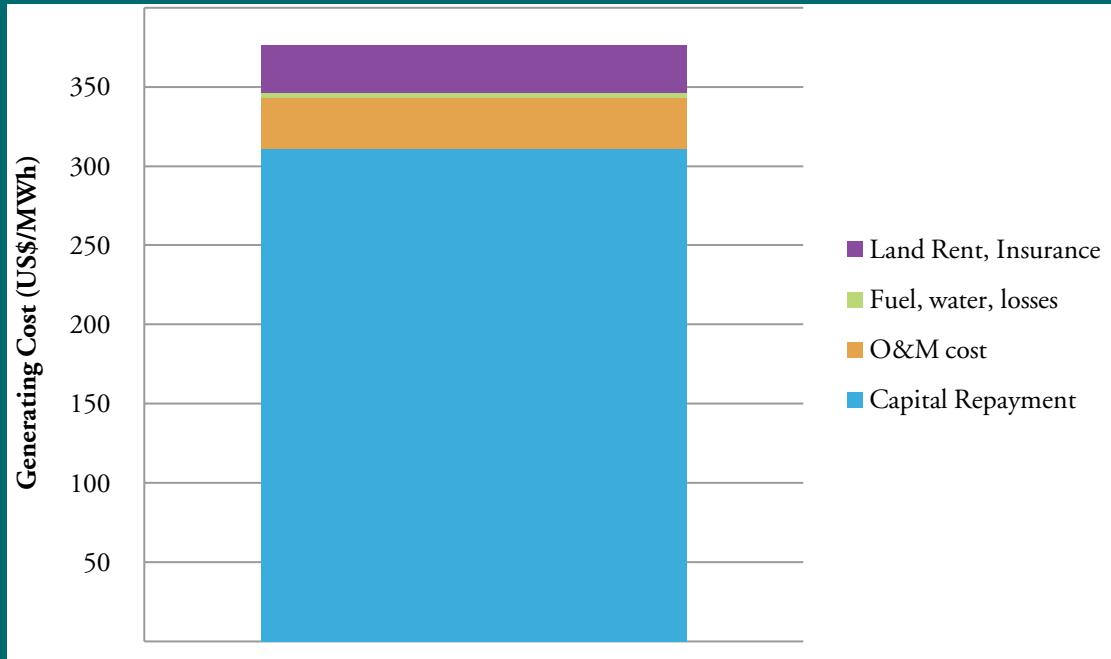

Figure 11: Generating Cost of a Parabolic Trough Plant

- Optimal siting of plants;
- Optimal sizing of plants: size may increase to 200 MW or 300 MW before losses in the solar field between the receivers and power island outweigh the benefits of increased size;
- Increase in storage capacity and capacity factor;
- Technological improvements across the range of plant;
- Increased competition in supply chain; and
- Learning rate effects with increase in cumulative built capacity, provided that build rate is sustained or increased.

4.2.8

Conclusions

Parabolic trough technology is currently the most established concentrated solar power technology. It can therefore be considered to be of relatively low technology risk. The main application is utility scale power generation, although it is also used for smaller scale power generation or process steam applications.

The relative maturity of this technology is an advantage, as this has allowed refinement of many elements of the system. A large number of projects are currently in development, as seen in Section 4.2.5, reinforcing the technical viability of the technology.

Drawbacks include:

- shortage of manufacturers for key components (such as the power trough, receivers and mirrors) limits available manufacturing capacity and increases supply lead times;
- limited maximum temperature, due to the limited concentration ratio achievable, which limits the maximum efficiency;
- requires to be installed on flat ground, typically with a slope of less than 3%.

Despite substantial financial support, the economic viability of this technology will depend greatly on the actual costs of completing projects currently under construction, as well as the effects of expected future reductions in costs from this baseline.

4.3 Power Tower

Power tower systems (see figure 12), also known as central receiver systems (CRS), consist of:

- a heliostat field;
- a tower and receiver;
- a power block; and
- an optional thermal storage system.

The field of heliostats (flat, dual-axis tracking mirrors) focuses direct normal solar radiation onto a receiver located at the top of a tower at the centre of the heliostat field. The receiver absorbs the concentrated radiation and transforms it into thermal energy in a working fluid, which is then pumped to the power block. The power block generates steam (from the heated fluid) to drive a conventional steam turbine and generator to produce electricity.

The temperatures achievable with power tower systems are greater than those achievable through parabolic trough technology, and are in the region of 400-550°C. Temperatures of up to 1000°C are being mooted for future plants that will have demonstrable improvements in beam focussing on the receiver. This would enable much higher efficiency of conversion from heat to mechanical energy in the steam turbine, and thence to electrical energy in the generator.

Although power tower technology is commercially less mature than parabolic trough technology, a number of components and experimental systems were field tested as early as the 1980s and early 1990s.

The principal components of power tower systems are described in further detail in the following sections.

4.3.1 Heliostat and the Tracking and Control Mechanisms

A heliostat is an instrument consisting of a mirror mounted on a structure which allows the mirror to rotate. This allows direct solar radiation to be steadily reflected in one direction, despite the movement of the sun. The heliostat should be positioned so that the reflected ray is consistently orientated towards the receiver.

Each heliostat is composed of a flat reflective surface, a supporting structure and a solar tracking mechanism. Currently, the most commonly used reflective surface is the glass mirror. Membrane technology is under development consisting of a thin film reflective membrane stretched across a mounting structure. This technology is still in its infancy and is not yet commercially available. Problems observed with stretched membrane heliostats include the durability of the reflecting membrane and possible shape change of the heliostats surface due to wind effects. Heliostat sizes vary widely and aperture areas of up to 150 m² have been assessed experimentally.

In order to function properly, the heliostats must be cleaned at regular intervals as dirty heliostats can greatly reduce the efficiency of the entire system.

One difficulty encountered with the Abengoa Solar PS10 pilot plant (in Spain) was related to the wind conditions under which the heliostats could be utilised. In wind speeds greater than 10 m/s the heliostats must be stowed (secured in a horizontal position) in order to avoid structural damage of the components. Very high wind speeds could cause damage.

The heliostat field is normally arranged to surround the power tower. The most common layouts utilise a full circular field or a surrounding field in a north/south direction.

The tracking system comprises an elevation drive and an azimuth drive which facilitate the movement of the heliostat to track the path of the sun throughout the day. To activate the



Figure 12: An Example of Solar Power Tower Technology

tracking, each heliostat has its own individual control system. The tracking algorithm takes into account various factors such as the distance from the heliostat to the receiver.

4.3.2 Receiver, Heat Transfer Medium and Tower

The receiver transfers the concentrated solar energy reflected from the heliostats to the transfer medium. Dependent on the technology, the receiver can be a boiler or steam drum. This directly produces superheated steam at around 550°C and a pressure of 160 bar for supply to the steam turbine or steam storage tank (as in the case of the BrightSource technology^[15]). Alternatively, molten salt can be used as the heat transfer fluid and heat storage medium – see Section 4.5 for further details of heat storage and molten salts.

The tower supports the receiver, which needs to be located at a certain height above the heliostats to avoid, or at least reduce, shading and blocking of the heliostats. Tower heights can vary from 50 metres to up to 165 metres depending on the distance of the heliostats from the tower.

Since the effectiveness of focussing irradiation on the receiver diminishes when the heliostats are at too great a distance from the receiver, large power projects may comprise of more than one power tower, each with its own heliostat field.

Experimental projects, such as the 2 MW Eureka tower constructed by Abengoa Solar, are testing higher temperature technologies to achieve increased efficiency.

4.3.3 Examples in Industry

Currently there is 44 MW of power tower capacity in operation, 416 MW under construction, and 1,291 MW at an advanced planning stage.

The first power towers to be built (of pre-commercial scale) were the 10 MW Solar One and Solar Two plants in southern California. Both installations were developed as demonstration plants. Solar One was operated from 1982 to 1988 and, after the initial test and evaluation phase, operated reliably.

In Solar One, the water was converted to steam in the receiver and used directly to power a conventional Rankine cycle steam turbine. The heliostat field consisted of 1818 heliostats with an

[15] BrightSource website, technology section

aperture area of 39.3 m². The plant generated power for eight hours per day at summer solstice and four hours per day close to winter solstice. Although Solar One demonstrated that power tower technology could be successful, it also revealed the disadvantages of a water/steam system, such as intermittent operation during cloud cover and the lack of thermal storage.

Solar Two was built to replace the original Solar One power tower. The aim of the re-designed Solar Two was to test and validate the use of nitrate salt technology, to reduce the technical and economic risk of power towers, and to stimulate the commercialisation of power tower technology. The plant was built with sufficient thermal storage capacity to allow it to operate at full capacity for up to 3 hours after the sun had set. The conversion of Solar One to Solar Two required a new molten salt heat transfer system including the receiver, thermal storage, piping, steam generator and a new control system.

The first European plant and the first commercially operational power tower plant to be installed was PS10, near the Spanish city of Seville, which has a capacity of 11 MW. This plant was installed by Abengoa Solar and was completed in the first quarter of 2006. The project has a heliostat field of 624 movable mirrors with a surface area of 120 m². This field concentrates the sun's rays on the top of a 115 m tower where the solar receiver and steam turbine are located.

A second plant, the 20 MW PS20, was installed in 2009 next to PS10; the design of PS20 was based on the original PS10 plant and included a number of significant improvements. These included a higher efficiency receiver, various improvements in the control and operational systems and a better thermal energy storage system. PS20 consists of a solar field made up of 1,255 heliostats with an aperture area of 120 m². This field concentrates solar irradiation on the top of a 162 m tower which produces steam to drive the electrical generator.

Plants under construction and at an advanced planning stage are dominated by large scale (29 to 200 MW) plants in the USA. In Europe, there is a 17 MW plant due for commissioning in Spain in 2011.

In June 2010 the World Bank approved a \$200m loan to co-finance a 100 MW power tower plant near Upington, South Africa.

In Rajasthan, India, ACME are commissioning a 10 MW plant, based on technology from eSolar (USA), and have plans to scale up to production of 50 MW units and implementation of utility-scale projects.

4.3.4

Conclusions

Power tower technology is the second-most proven technology for utility scale power generation after parabolic troughs.

Higher operating temperatures allow for higher performance and hence potentially lower costs than parabolic troughs. However, there is very limited information available on costs which have been achieved, and on what is likely to be achieved in the future; consequently, cost estimates remain uncertain.

Many developers are now adopting receivers which produce steam directly in the receiver, as this type of steam receiver is currently of lower cost and risk than molten salt receivers.

A major factor in the scalability, performance and cost of energy using power towers is the effectiveness with which the heliostats focus the beam on the central receiver. This is an area suitable for significant technical development and potential cost reduction.

The terrain requirements for power tower plants are not as restrictive as those for parabolic trough technology, and plants can be installed in areas with terrain gradients of up to 5%.

The actual costs of completing projects currently under construction, combined with future reductions in costs from this baseline will be key to economic viability of power tower technology, even where substantial economic support is in place.

4.4 Parabolic Dish

Parabolic dish technology offers a highly efficient conversion from solar energy to electrical energy, as well as full scalability. However, installed costs are likely to be higher than the costs of parabolic trough, Fresnel reflector and power tower systems.

There are two forms of parabolic dish: one concentrates radiation on to a photovoltaic collector (concentrated PV or CPV) whilst the other concentrates radiation on to a heat receiver for a heat engine, which may be a Stirling engine or Rankine cycle micro-turbine and generator. CPV is covered in Section 4.9.

A total capacity of 3 MW of thermal parabolic dish systems is in operation or construction, 387 MW can be considered to be at an advanced planning stage, with and a further 1,600 MW at a less advanced stage. Most of the planned capacity comprises three large projects proposed by Tessera Solar/ Stirling Energy Systems.

4.4.1 Stirling Engines

A Stirling system consists of a parabolic dish-shaped collector, a receiver and a Stirling engine. The collector focuses direct normal solar radiation on the receiver, which transfers heat to the engine's working fluid to drive a generator.

Stirling engines are available for various applications in a wide range of sizes, configurations and levels of complexity. They have been under development over several decades. The recent focus on small-scale Stirling engines has been for micro-cogeneration applications, as well as the CSP application. At the small and micro-scale the engine configurations and details are simplified to minimise unit costs, but this needs to be balanced against the resulting lower efficiency and possibly reduced reliability or longevity.

The principal advantage of a Stirling engine design for CSP is that the focused heat from solar radiation is applied directly to the heat engine-generator unit. Dishes typically provide a heat source at a temperature of 750°C. The Stirling engine



Figure 13: An Example of a Parabolic Dish System

uses heat to vary the pressure inside a hydrogen-filled sealed chamber, driving pistons to produce mechanical power. The world's highest solar-to-grid efficiency of 31.25% was achieved by Stirling Energy Systems in 2008^[16].

Stirling Energy Systems' sister company, Tessera Solar, plans to install 1.85 GW in south-west USA. Initial plans are to install 10,000, 11.5 metre 25 kW solar dishes totalling 250 MW. In subsequent projects, 850 MW and 750 MW would be installed and in latter phases, Tessera / Stirling Energy Systems could increase project capacity by a further 1,750 MW. If this is realised, the project would use up to 70,000 twelve metre diameter solar dishes. Investment is estimated to be in the region of \$1bn^[16].

The other principal players operating in the market are Wizard Power which is developing the 40 MW SolarOasis plant 4km north of Whyalla in South Australia using a Rankine cycle engine, and Infinia who are developing Stirling engine and dish technology. A 70 MW dish plant has been proposed for Spain.

Stirling engines may be of particular benefit in applications such as water pumping, where mechanical work is required, to drive a pump, rather than electricity for other purposes.

[16] Stewart Taggart; CSP: dish projects inch forward; http://www.trec-uk.org.uk/articles/REF/ref0904_pg52_55.pdf (accessed 26/07/2010); renewable energy focus July/August 2008

4.4.2

Conclusions

Implementation of parabolic dish projects for utility-scale power generation is still at the demonstration stage.

Parabolic dish technology offers full scalability and flexibility of siting. Each dish is self-contained and does not require level ground or close proximity to other dishes and hence is less exacting in its siting needs. The ease of finding a site combined with the relatively high solar to grid efficiency provides a basis for ambitious plans for construction of large projects using tens of thousands of dish / Stirling engine units.

However, rapid expansion is largely dependent, in the short term, on the achievements of one developer. Completion of the implementation cycle for commercial scale projects has yet to be demonstrated and uncertainties include:

- Performance of production units, including efficiency and reliability
- Ramp up of serial production of the units, including quality and costs
- Longevity of units.
- Overall costs for construction of the site infrastructure, including the foundations, access, and electrical connections for the numerous dish units.
- Robustness of implementation plans, costing and commercial case.

4.5 Power Block

Since parabolic trough is the most established technology, the description of typical BoP will focus on this type of plant.

The power block of a CSP power plant is very similar to that of a conventional thermal electricity generation plant and their use and construction are considered proven technology in the industry. The steam required to drive the turbine is generated via the heat transfer fluid and heat exchangers, rather than by the combustion of fossil fuels.

Due to the generally lower temperatures of heat from CSP plants compared with conventional combustion plants, and the smaller size of the plant, the efficiency of the steam plant is likely to be less for CSP than for conventional thermal generation projects, as explained in Section 4.2.6. The number of stages in the steam turbine may be less and the effectiveness of the condenser may also be reduced (see Section 4.7).

The power system boiler is largely designed on a project-specific basis and requirements depend on the characteristics of the CSP technology used.

Turbines are supplied by established manufacturers, such as Siemens, GE, Alstom or MAN Turbo. The Siemens SST-700 steam turbine, with a capacity of up to 175 MW is commonly used for CSP applications. However, a specific CSP system steam turbine has not been released at this time.

Due to the nature of CSP, the heat exchangers/boilers and turbines are subject to significantly more thermal cycling (heating and cooling) than conventional steam plants, which run for long periods at a time without outages. This cycling reduces the lifetime of the heat exchangers / boilers and can cause wear and damage to the turbine if the steam quality is not maintained. Low temperature steam turbines which are being proposed for larger solar fields or direct steam systems may not be well tested technology solutions.

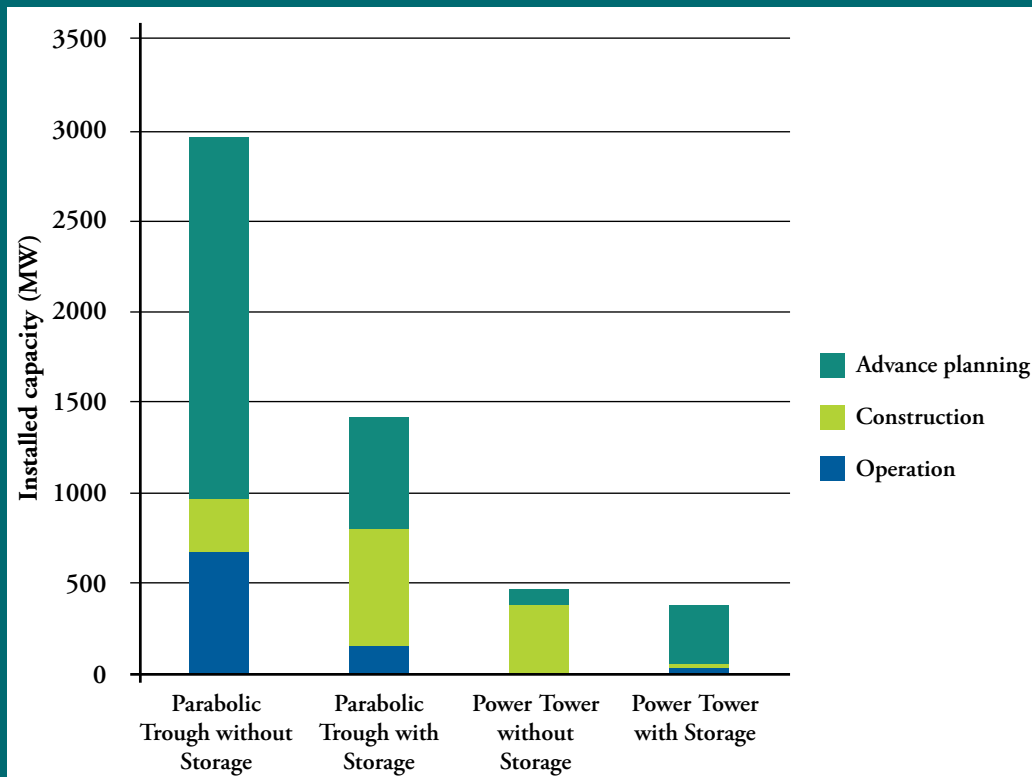

Figure 14: Implementation of Energy Storage in CSP Plants

4.6 Energy Storage and Supplementary Heating

4.6.1 Overview

Energy storage is an established option for parabolic trough and power tower plants. Figure 14 compares the uptake of CSP plants with and without energy storage.

CSP with thermal energy storage, hydro with impoundment, and biomass are the only established renewable power generation technologies which offer load matching capability^[17]. It will become increasingly important for plants to offer this capability as both the need to reduce reliance on combined cycle gas turbine (CCGT) plants and the increasing proliferation of wind and solar power will reduce overall load matching capacity in power grids. This will ensure further financial premium to support power plants with energy storage.

The choice of whether or not to include energy storage depends on local market conditions.

To date, in the south-west USA, parabolic trough plants have typically been installed without energy storage as the solar resource is coincident with times of peak load (largely due to air conditioning). However, some parabolic trough projects under construction, such as the 280 MW Solana project, and other large projects being planned for the south-west USA, will incorporate energy storage.

In contrast, in Spain the feed-in tariff mechanism has encouraged the use of energy storage and the technology has become established in parabolic trough plants.

Power tower plants tend to include energy storage although direct steam plants such as the Ivanpah plants in the USA (370 MW) may not have energy storage.

[17] Excepting coincident resource with load demand, curtailment of generation, and use of separate energy storage plants such as pumped hydro or hydrogen.

Energy storage in CSP plants was first demonstrated by Solar One and Solar Two 10 MW power towers; it has also been demonstrated in a number of 50 MW parabolic trough plants, the first of which was the Andasol 1 plant commissioned in 2008. Current parabolic trough plants with storage typically have between 6 to 8 hours energy storage at full plant capacity. Some power tower plants have up to 15 hours storage. Such storage is sufficient to accommodate daily variation in solar irradiance and load demands, and enables the capacity factor of parabolic troughs to be increased from 23-28% without storage to 36-41% with storage. Capacity factors for power tower plants range from 24% to 67%, the lower figures relating to plants without storage, while the higher figures are from the Solar Tres / Gemasolar plant, which has storage.

It should be noted that overall energy output is likely to be reduced as a consequence of incorporating a storage system, but the system and economic benefits of the output matching demand in real time may outweigh these losses. The higher capacity factors from storage-equipped plants are likely to reflect a smaller turbine running at a higher percentage output for more hours.

4.6.2 Storage Medium (Including Molten Salts)

Heat storage using a liquid storage medium typically comprises two tanks: a hot tank and a cold tank. During high solar irradiance, excess heat from the solar field is transferred to the storage medium which is then transferred to the hot tank. During low solar irradiance and high load demand, heat from the hot tank is transferred to drive the steam turbine. The storage medium is transferred to the cold tank once the heat has been extracted from it. The cycle is completed by

transferring the storage medium from the cold tank for heating from the solar field.

Molten salt is the current storage medium of choice, although it has drawbacks, primarily logistical, as handling is complicated. The molten salts used for energy storage, and sometimes for heat transfer in CSP plants typically comprise nitrate salt mixtures of 60% sodium nitrate and 40% potassium nitrate. The use of calcium nitrate is a future possibility. The use of molten salts as a heat transport fluid is well established in the chemicals and metals industries.

Innovation in storage media continues, including use of pressurised steam, specialised salts such as liquid fluoride salts, phase change materials, thermo-chemical storage using ammonia, solids such as concrete or graphite, and hydrogen. Short-term energy storage may be provided using pressurised steam where the heat transfer fluid is direct steam, such as the 0.5 hours storage in the 64 MW Nevada Solar 1 parabolic trough plant and the 1.0 hour storage provided in the 11 MW PS10 and 20 MW PS20 power towers.

4.6.3 Supplementary Heating (Use of Natural Gas or LPG)

The freezing of salts in storage tanks and circuits must be prevented, both overnight and during maintenance outages when heat is not supplied from the solar collectors and there is insufficient residual heat in the fluid, as the freezing points of the salt solutions are typically above 200°C, and hence well above ambient temperatures. This is generally achieved through the use of natural gas or liquefied petroleum gas (LPG) for direct heating or electrical heating.

Partly due to the necessity for heating to prevent freezing of molten salts and to provide essential back-up power, and also to improve project economics, the use of natural gas or LPG is generally permitted by feed-in tariff mechanisms to generate up to a specified proportion of the total power generated. For example the tariff system in Spain allows up to 15% of power to be generated from fossil fuels, and the SEGS plants in the USA are permitted to use natural gas to supply up to 25% of the heat energy into the turbines. Since continuity of power generation and ability to meet transient loads significantly increases the value of electricity sales, operators generally use natural gas or LPG to generate power up to these limits and export the excess output that is not required for essential self-loads. For example, generation from fossil fuels may be used in the evening or in the early hours once storage has depleted. This is much more cost-effective than increasing the size of solar field or storage, and hence significantly improves the overall project economics.

In hybrid CSP plants, generation from natural gas is combined with solar energy generation. Natural gas may be used to increase the steam temperature above that provided from the solar field, to increase the efficiency of the steam power plant. In the case of integrated solar combined cycle plants, generation from natural gas is dominant and a combined cycle gas turbine and steam turbine is used to maximise generation efficiency from the natural gas – this is discussed in Section 4.8.

4.6.4 Costs

Thermal storage has been reported to add 5% or US\$50/MWh to the generating costs of CSP. However, given variations in plant configuration, technical developments, changes in the costs of CSP technologies (including the solar field, storage, and steam power plant), and value of peak electricity, the economic case for inclusion of energy storage should be assessed on a project by project basis, and in relation to local electricity demand patterns.

4.6.5

Conclusions

Molten salts storage is technically proven but may be considered to be at an early stage of commercial demonstration.

As thermal storage experience grows, it is likely that the operational flexibility of CSP will be broadened with subsequent positive impacts on the economics.

4.7 Cooling and Water Consumption

4.7.1 Cooling Options

In common with conventional steam turbine power generation plants, all CSP plants used for power generation condense the steam exhausting from the steam turbine. This is necessary to achieve an acceptable efficiency when converting heat energy to mechanical energy, and to enable most of the purified water to be re-circulated back to the feed system and steam generators. As explained in Section 4.2.6, achieving a lower condenser temperature directly increases the theoretical efficiency limit of a turbine system.

4.7.2 Water Consumption

The main cooling options for the condenser are summarised in Table 4. Although dry cooling uses less water, initial capital costs are higher. Wet cooling is the most cost effective approach in water rich areas. Dry cooling should be considered for water-stressed areas.

Conventional CSP plants such as parabolic troughs and power towers typically consume large volumes of water for cooling to condense steam, provide make-up water for the steam cycle, and for mirror washing. Water requirements for different CSP technologies are given in Table 5.

Table 4: Condenser Cooling Options

Category	Condenser cooling method	Water and energy use	Application
Wet	Evaporative cooling in natural draft cooling towers.	5% of cooling water typically lost through evaporation.	Common in large scale power plants.
	Evaporative cooling using forced draft with down-flowing water in box type structure.	Air / evaporation temperature in hot climates may reduce steam cycle efficiency but not as severely as with dry cooling.	Most common form for CSP plants.
Dry	Air cooled condenser. Steam is condensed in a closed system including radiator, with heat extracted via high forced air flow over finned tubes.	Fan loads 0.5% to 1.5% of power generation. Air temperature in hot climates reduces steam cycle efficiency. Overall electricity generation reduced by 5-7% compared with wet evaporative cooling.	More adaptable to power towers than parabolic troughs. Plant costs are 5% greater than those of wet evaporative cooling. Overall generating costs typically 10% higher than that of wet evaporative cooling.
Hybrid	Cooling tower with dry or air cooled section above wet or water cooled section.	Wet section used in “hot” season / conditions to maintain reasonable efficiency. Dry section used in “cold” season / conditions that may reduce water consumption to around 50% of that used during wet cooling.	Due to its complexity, this option is only likely to be applicable to larger scale CSP plants.
Direct	Direct cooling from ocean, lake, river, cooling ponds, or recycled grey water (wastewater) through heat exchanger.	Lowest energy use and highest steam cycle efficiency if low temperature cooling source available.	Lowest cost cooling system. Preferred option for power plants which can be sited by sea, for example nuclear power plants. No known CSP plants using direct cooling to date except Palmdale plant in which it is planned to use recycled wastewater.

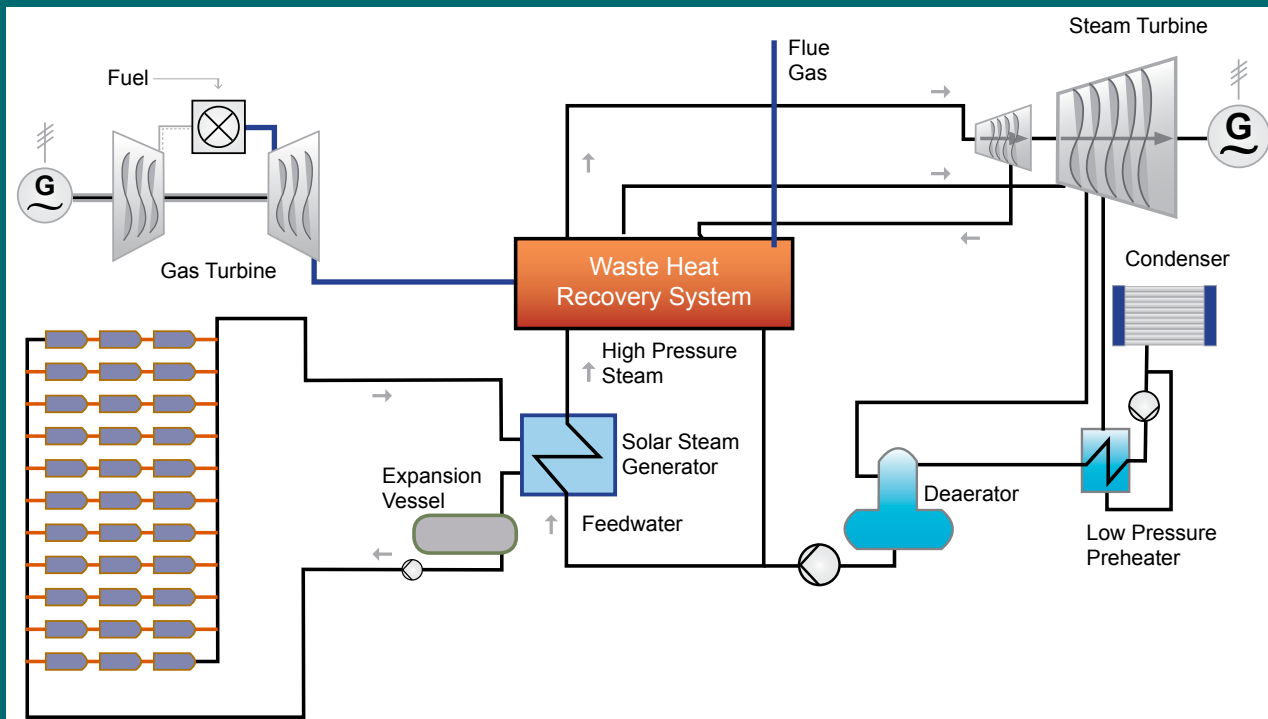

Figure 15: ISCC Plant Schematic^[20]

As the locations with the best solar resource are typically in arid areas, the supply of water can be a costly and complex exercise. Alternatives to water cooling should therefore be considered. Such methods are discussed in Section 4.7.1. The US Department of Energy (DoE) reports that dry cooling requires approximately 350 litres per MWh for either type of plant. Hybrid wet/dry systems are also being developed which balance water usage against cost and yield loss.

All systems require water for mirror washing; this is typically in the region of 60 to 90 litres/MWh.

4.8 Integrated Solar Combined Cycle

It is possible to combine a solar thermal plant with a fossil fuelled thermal generation plant, either by integrating with

existing thermal power plants or as part of a new hybrid installation. This is known as Integrated Solar Combined-Cycle (ISCC). All combined cycle plants falling under this category use gas turbines in conjunction with steam turbines as the established conventional thermal power plant known as Combined Cycled Gas Turbine (CCGT). A typical ISCC plant schematic is provided in Figure 15.

Two different thermodynamic cycles, a gas-turbine Brayton cycle and a steam-turbine Rankine cycle, are combined in a single system through a Heat Recovery Steam Generator (HRSG). Fuel is combusted in the gas turbine in the conventional way, and the hot exhaust gas goes through the HRSG. Here the energy from the gas generates and superheats steam to be used in the steam turbine cycle. In ISCC plants solar heat from CSP technology is integrated either at high

Table 5: Water Requirements for Different CSP Plant Types

Plant type	Water demand, l/MWh ^[18,19]
Parabolic trough, water-cooled condenser	2700-3500
Fresnel reflector	Up to 3800
Power tower, water-cooled condenser	1900-2300
Parabolic dish (water required for mirror washing only)	60-90
CPV (water required for mirror washing only)	60-90

[18] CSP Today article – Cost efficiency Vs water usage, and US DoE
 [19] US Department of Energy (2001); Concentrating Solar Power Commercial Application Study: Reducing Water Consumption of Concentrating Solar

Power Electricity Generation; http://www1.eere.energy.gov/solar/pdfs/csp_water_study.pdf (accessed 26/07/2010)
 [20] Graphic courtesy Abengoa Solar.

pressure in the HRSG or directly in the low pressure casing of the steam turbine. The general concept is an oversized steam turbine, using solar heat for steam generation and gas turbine waste heat for preheating and superheating steam^[21].

Similar to conventional CCGT, the gas turbine is operated to match electricity demand on the grid, ensuring higher value of the electricity generated. Night running increases the load factor for the steam turbine and condensing plant compared with a solar-only system, so improving economics. Since the fossil fuelled gas turbine and its waste heat to the steam turbine provide both peak load-matching and continuity of supply, ISCC plants do not utilise heat storage.

All ISCC plants to date use parabolic trough technology in the solar field. The CCGT power plant typically has a generating capacity of five to twenty times that which would be supplied by the solar field on its own.

The steam temperatures provided from the gas turbine exhaust through the HRSG are higher than can often be achieved from CSP solar fields, which enables higher efficiency operation of the steam turbine overall. Furthermore, it is cost effective for the larger scale steam turbine to have more stages than a small-scale steam turbine for a CSP-only power plant, providing a further increase in steam turbine efficiency. Hence, the solar energy to electricity conversion is more efficient.

The cost of the steam turbine, condenser, grid connection, and site infrastructure are shared with CCGT power plant. The incremental costs for a larger steam turbine, the condenser and cooling system are much less than the overall unit cost in a solar only plant, and an integrated plant does not have the thermal inefficiencies associated with the daily steam turbine start-up and shut-down.

Due to these advantages much of the CSP capacity outside the USA and Spain is made up of ISCC plants; a selection of projects that are currently under construction or recently completed is listed in Table 6.

Plant	Parabolic trough capacity (MW)	CCGT Capacity (MW)
Ain Beni Mathar, Morocco	20	452
Hassi R'Mel, Algeria	25	130
Kuraymat, Egypt	20	115
Martin County, Florida, USA	85	Existing 450MW

4.9 Concentrated Photovoltaic (CPV)

CPV uses concentrating optics to focus light onto small, high efficiency cells (see Figure 16 & 17). These high efficiency cells are more expensive than the cells used in normal photovoltaic plants due to the higher efficiency and operating temperatures required. The concept is to reduce the cost of electricity by minimising the amount of expensive photovoltaic material required; the cost of the silicon cells typically comprises more than half of the module cost.

With research cell efficiencies of over 40%, CPV is the most efficient of all the PV technologies. Efficiencies have been increasing by approximately 1% per annum and are expected to peak between 45% and 50%.

4.9.1 Manufacturers and Examples from Industry

Installed capacity of CPV remains low. Only four companies, Amonix, ENTECH, Guascor Foton and SolFocus, have installed plants of more than 1 MW. Amonix-Guascor Foton, a joint venture, built the largest CPV plant at Parques Solares de Navarra, 7.8 MW, in 2008.

[21] A. Fernandez-García, E. Zarza, L. Valenzuela, M. Perez (December 2009): Parabolic-trough solar collectors and their applications; http://www.sciencedirect.com/science?_ob=ArticleURL&_udi=B6VMY-4YNB5Y6-1&_user=8452154&_coverDate=09%2F30%2F2010&_rdoc=1&_fmt=high&_orig=search&_sort=d&_docanchor=&view=c&_searchStrId=1413265686&_rerunOrigin=google&_acct=C000050221&_version=1&_urlVersion=0&_userid=8452154&md5=dae73bcebffd373c8a628c8a942157eb (accessed 26/07/2010); Renewable and Sustainable Energy Reviews, Volume 14, Issue 7, September 2010, Pages 1695-1721

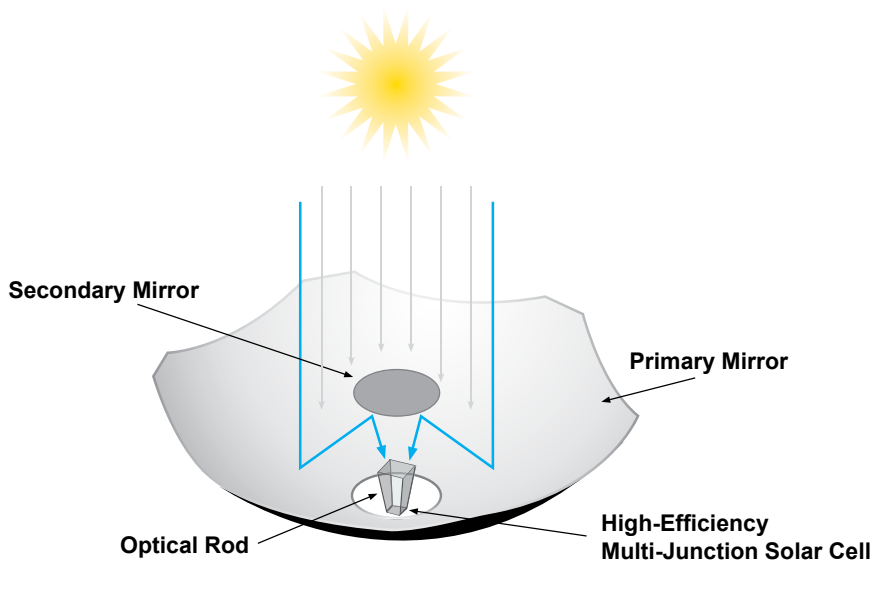

Figure 16: Illustration of Typical CPV Concentrating Mechanism



Figure 17: Example of SolFocus CPV Installation

Suncore Photovoltaics, a joint venture between Emcore and San'an Optoelectronics, is pursuing multiple projects as part of the 280 MW solar energy plan recently announced by the Chinese Government^[22].

4.9.2 CPV Advantages and Disadvantages

The principal advantages of CPV are that it requires water for cleaning purposes only, is modular and is more flexible than thermal CSP in terms of site requirements. Like parabolic dishes, CPV systems can be installed at sites with undulating terrain.

Commercialisation of CPV is held back by the availability of concentrator cells. A number of new companies with the capability for epitaxial (single-crystal) growth of multi-junction cells have started competing with the established manufacturers Emcore^[23] and Spectrolab. The availability of cells is expected to increase rapidly following the entry of these new suppliers.

Although some standards are available, many key areas are not covered in comparison with conventional PV. The most critical of the required standards is 'IEC 61853, Photovoltaic (PV) module performance testing and energy rating', which has been in draft for over two years. In the absence of this standard, nameplate energy ratings are debatable and hence some investors have lower confidence in CPV technology than in conventional PV. In certain situations financing risk may be reduced if CPV is installed alongside a mature technology such as flat plate crystalline PV in a hybrid installation.

4.10 Linear Fresnel Reflector

Linear Fresnel reflectors differ from parabolic troughs in that the absorber is fixed in space above the slightly curved or flat Fresnel reflector. Several mirrors are fitted into the system, all of which focus their energy on the central line-receiver. In some cases a small parabolic mirror is added to the top of the receiver to further focus the sunlight.

The options for siting and orientation of linear Fresnel plant are similar to those for parabolic trough plant. A flat land area is required, and it is usual to orientate the reflectors in a north-south direction, in order to maximise sunlight captured throughout the day.

Linear Fresnel reflector technology has historically operated at the lowest temperature of the available CSP technologies.

4.10.1 Applications and Examples

Implementation of linear Fresnel plants has been led by Areva Solar (previously Ausra, USA), with the 0.36 MW Liddell plant in Australia commissioned in 2007 and the 5 MW Kimberlina plant commissioned in 2008. Areva Solar (Ausra) technology has been designed for application in utility-scale solar and solar hybrid plants, steam augmentation and industrial processes such as desalination and food processing. The overall concept was to design the technology to be utilised at the MW scale, although

[22] Emcore is the only vertically integrated CPV product provider at present, see: <http://www.euroinvestor.co.uk/news/story.aspx?id=11207570>

[23] [yourrenewablenews.com](http://www.yourrenewablenews.com); EMCORE enters into multi-year agreement to supply Solar systems for utility scale power projects in US; http://www.yourrenewablenews.com/news_item.php?newsID=4085

Areva Solar may be withdrawing from the construction of large utility power plants to focus on heat plants for industrial processes or smaller scale generation projects (up to 50 MW) where the permitting process is more straightforward.

The second major player in utility scale linear Fresnel plants is Novatec Biosol which is currently constructing the 30 MW Puerto Errado 2 (PE2) project. This follows the commissioning of their 1.4 MW Puerto Errado 1 (PE1) project in Murcia, Spain in 2009.

Other companies such as UK based Heliodynamics have developed and implemented facility scale systems for applications where the solar heat is used directly, without conversion to electricity, for air conditioning and cooling in

buildings for hospitals, factories and schools. These companies may develop and scale up their technologies for applications such as process heat, desalination and power generation in the future.

4.10.2 Reflector and Structure

The mirrors utilised in linear Fresnel technology are generally manufactured from float glass and have a thickness of around 1-2 mm. This allows the mirror to be sourced from a number of manufacturers worldwide, unlike those of parabolic troughs where precision bent mirrors are required. Fresnel mirrors are relatively cheap to procure at around \$9.8 and 3 kg per square metre, which corresponds to approximately one third of the weight of a parabolic trough mirror.



Figure 18: Kimberlina solar thermal energy plant, installed by AREVA Solar (USA)

The structures for mounting the mirror systems in linear Fresnel systems are simpler than other CSP technologies allowing a higher volume of automated manufacture. As the mirrors do not need to support the weight of the receiver, the overall weight of the structure can be reduced in comparison to parabolic trough technology. As linear Fresnel systems use mirrors located close together within a few metres of ground level, the wind has a reduced effect on the structure, allowing for a lighter structure to be used. When not in use, the mirrors can turn upside down for further protection from the wind, sand storms or hail.

4.10.3 Receiver and Heat Transfer

Linear Fresnel reflector plants use steam as the heat transfer fluid.

The receiver of the Areva Solar / Ausra system is made from steel tubes with heat absorption coating. Water is vaporised within the receiver tube. The steam is piped directly to the required application, whether it is for electricity generation, steam augmentation or industrial processes. This allows for the elimination of expensive receivers, performance reducing heat exchangers, and the costly transfer fluids that are required by parabolic trough technology. The simplification of components required by the technology means they can be sourced from a variety of manufacturers.

Novatec Biosol proposes to use evacuated tubes supplied by Schott on its future projects. These are similar to those used by parabolic troughs, which will enable superheated steam with a temperature of 450°C to be supplied, compared with a temperature of 270°C in previous plants.

Due to the lightweight nature, the simplicity of the receiver and carrier and the absence of environmentally hazardous heat transfer fluids, the installation of a linear Fresnel solar field is much simpler than that of parabolic troughs. The modular design of the reflector and receiver units and prefabricated components reduce the need for skilled labour, particularly in small scale plants for heat applications.

4.10.4

Conclusions

In the near term, it appears that linear Fresnel technology is most likely to be implemented in heat, rather than electricity generation applications, where its lower cost can more than outweigh its lower performance compared with the other CSP technologies.

Its use for utility scale power generation is likely to depend on:

- The commercial success of the Puerto Errado 2 (PE2) project and a small number of other proposed projects.
- Commercial success of small scale applications, economies of serial production, and transfer of technology and production from small scale to larger scale units.
- Technology improvements and cost reductions achieved for other CSP technologies.
- Continuing substantial economic support for CSP power generation.

5. SITE SELECTION

As discussed in Section 3, CSP technology can only capture the direct normal irradiance (DNI) component of the solar resource. This is a primary driver in site selection. Prime CSP locations typically require DNI exceeding 2,200 kWh/m² per year. The site screening threshold should be determined taking into account the envisaged technology, plant design, and region-specific factors such as the cost of grid connection, power prices, and the additional economic support which will be available. When considering a technology for a specific site, the following factors should be considered:

- Nature and scale of energy generation plant, for example utility scale power generation or process steam augmentation.
- Land availability providing sufficient direct irradiation and area which is within slope limits for the candidate technologies. If land availability is limited this may indicate a preference for a high efficiency technology to capture, convert and generate the required amount of energy.
- Economic support available and affordability. Minimum generation cost (\$/MWh) will generally determine the final choice of technology, irrespective of energy capture and conversion efficiencies.
- Load matching requirements, and value of peak energy, will determine the choice of energy storage system and its capacity.
- Water availability is likely to determine the choice of condensing system.

Regions with high levels of airborne dust, haze or smog are not suitable. This often rules out sites near large cities, particularly in arid developing nations. Higher altitudes lead to clearer skies and higher DNI, so accessible high altitude locations can be considered.

CSP also generally requires land with minimal gradient, although parabolic dishes and power tower technology are not as sensitive to slope as are parabolic troughs or linear

Fresnel reflectors. An average slope of 3% or less is preferable for parabolic troughs and linear Fresnel reflectors, and 5% for power towers. Parabolic dishes and CPV, due to their modularity, can be installed on steeper slopes. CSP may require less land area per MWh than PV, depending on the technologies employed.

A far greater quantity of water is required for parabolic troughs, power towers and linear Fresnel reflectors than for solar PV plant, due to the need for turbine condenser cooling. Depending on whether dry or wet cooling is employed, a large quantity of water is required and therefore a local water source at an environmentally acceptable and economic price is essential.

6. ENERGY YIELD PREDICTION

6.1 Site Conditions and Data Measurements

As for PV plants, predicting a plant's energy yield begins with quantifying the available solar resource. Accuracy is crucial in this area, due to the CSP requirement for clear skies and high DNI.

Depending on the location, DNI constitutes between 50% and 90% of Global Horizontal Irradiance (GHI), and varies considerably in time and location. Annual DNI can vary by up to 30% from one year to the next, so irradiance data should be measured over as long a period as possible in order to increase the confidence in the long-term prediction. DNI data availability varies greatly by location, and local data may not be available. The availability of local data will determine how much site data is required, but one year is considered a minimum. Measure-correlate-predict (MCP) methods can then be used to compare satellite and local meteorological data against site measurements. Use of satellite data on its own can result in over-estimation of energy yield due to the effects of near-ground haze which may not be measured by satellite.

Ambient temperature and relative humidity should be measured. The site wind speed is also important, as the plant may need to shut down when wind speeds exceed a certain limit.

The energy yield prediction must therefore be based on measurement and analysis of the solar resource and other conditions at the site combined with a detailed analysis of the proposed technology, including thermodynamic modelling of the plant design.

6.2 Technology Characteristics

Each CSP technology has its own energy yield characteristics. A difference when conducting energy yield analysis for CSP, as opposed to PV, is the added dimension of the thermal conversion technology (with the exception of parabolic dishes). CSP requires that thermal inertia and the efficiency of the Rankine cycle steam turbine is accounted for. This, in turn, depends upon the form of cooling system employed. However, unlike PV, CSP does not lose efficiency due to degradation over time, or losses in inverters. Higher ambient temperatures generally increase efficiency, providing that the condenser performance is not adversely affected,

Modelling of candidate technology systems for a particular project therefore needs careful consideration. Whereas empirical guides based on previous project experience can be used for preliminary scoping, proper definition of the project and performance modelling will require detailed information and analysis of:

- Site conditions and resource data.
- Site layout for each technology.
- Thermodynamic modelling of each candidate technology system.

6.3 Energy Yield Modelling

Several computer based energy yield and optimisation software tools have been developed to model the performance of a variety of photovoltaic systems (including CPV) and concentrating solar power (CSP) systems including parabolic trough, power tower, and dish-Stirling systems.

Two categories of models can be found: physical models based on heat transfer and thermodynamic principles, and empirical models based on data obtained from performance analysis of installed systems. Although physical models are generally more flexible than empirical models, for which only a limited range of system components can be included, they also add more uncertainty to performance predictions than empirical models. Models used for each technology are described below.

- **CPV** – models typically use the plant layout, technical specifications for the PV modules and inverters, tracking parameters and weather data for the site.
- **Parabolic Trough** – models typically use the plant design and layout, optical and technical parameters for the collectors, receivers, power block, heat transfer fluid, thermal storage system (if any) and cooling system, as well as control parameters and weather data for the site.
- **Power Tower** – models typically use the heliostat configuration, technical parameters for the tower, receivers, power block, thermal storage system (if any) and cooling system, as well as control parameters and weather data for the site.
- **Dish-Stirling** – models typically use the solar field layout, technical parameters for the collectors, receivers and Stirling engine, and weather data for the site.

7. PROJECT IMPLEMENTATION

7.1 Overview

For commercial projects completed to date, few major project problems have been reported in the public domain. It can be considered that the base technology, at least for parabolic trough plants is proven.

Engineer Procure Construct (EPC), Design Build Operate (DBO), or Build Own Operate (BOO) contracting strategies are all established in the CSP sector. However, long term operating experience is confined to Florida Power Limited's SEGS plants in the USA.

There are very large cost uncertainties and some planned projects are on hold or being redeveloped as PV solar generation projects due to relative costs, economic support, and uncertainties.

As with any industry that depends on government policy to set subsidies, there is potential for a boom and bust cycle in the CSP industry, unless consistent support is available with appropriate long-term tapered reductions.

7.2 Design

Various technology-specific design characteristics have been considered in Section 4. Some of the main design parameters for CSP projects in general are considered here.

7.2.1 Project Size and Land Area

Whilst many current CSP projects are of 50 MW capacities, many reports indicate a capacity of 200 MW would be more cost-effective. A rule of thumb indicator for the ratio of installed capacity to land area is around 0.3 MW/ha.

7.2.2 Load Matching Generation

Load matching options for CSP plants (excluding CPV) are considered in Table 7, indicating the relative size of the steam turbine and heat storage for a given size of solar field.

At present the cost of the solar field and storage are more significant than variations in size of the steam power plant, and other plant such as natural gas fired plant provides peak power. Hence most current plants follow an intermediate load matching regime.

7.2.3 Solar Multiple

The ratio of installed capacity of the steam turbine to the size of solar field varies with the project design, particularly depending on the integration of storage.

The solar multiple is defined as:

$$\frac{\text{Actual area of Solar Field}}{\text{Area required to operate turbine at design output at time of maximum solar irradiance}}$$

Plants without storage have an optimal solar multiple of roughly 1.1 to about 1.5 (up to 2.0 for linear Fresnel Reflector plants), depending primarily on the amount of irradiation the plant receives and its variation through the day. Plants with large storage capacities may have solar multiples of up to 3 to 5.

7.2.4 Capacity Factor

Currently the capacity factors of parabolic trough plants generally fall in the range of 23-28% without storage and 36-41% with storage. Capacity factors for power tower plants range from 24% to 67% with the lower end of the range applying to plants without storage and the higher figure applying to the Solar Tres / Gemasolar plant which includes storage.

Improvements in effectiveness of storage should enable capacity factors to be increased in the future. However, since the capacity of the plant is not directly determined by the size of the solar field, an increase in capacity factor does not usually give a proportionate reduction in generating costs.

7.2.5 Grade of Heat

The grade of heat refers to the temperature and pressure of the heat transfer fluid delivered from the receiver to the heat storage or steam power plant after transfer losses. The grade of heat is important since:

- High grade heat may enable more effective and lower cost heat storage; and

- High grade heat enables more efficient conversion of heat energy to mechanical energy (and thence to electrical energy) in the steam turbine.

7.3 Development

Development requirements will be highly specific to the region and regulatory regime for planning and permitting in the region, including specific regulations applying to land use, water use, and power / renewable energy projects.

The size of the project may be a major factor in determining the regulatory regime which applies and hence the time and likelihood of progressing projects through the planning and permitting process.

Table 7: Load Matching Options

Load matching regime	Capacity of steam turbine	Capacity of storage	Factors favouring application
Intermediate load – coincident solar irradiation and loads	Medium	Minimum	Locations where air conditioning or cooling plant provide high proportion of grid load. Projects where minimum investment cost is required.
Intermediate load – delayed loads	Medium	Medium	Supply evening loads. Common solution with current storage costs.
Peak load	Large	Large	High peak power price premium. Low cost storage technology available.
Base load	Minimum	Large	High power price premium for continuous generation. Low cost solar field and storage technologies available.

7.4 Engineering, Procurement and Construction

The CSP sector is dominated by several solar energy technology companies and affiliates who are experienced in:

- CSP technologies;
- CSP project development; and
- Undertaking or managing CSP projects on an EPC basis.

Examples of solar energy technology / EPC companies for parabolic trough developments active in Spain and USA include:

- Acciona Solar;
- Abengoa Solar / Abener;
- Solar Millennium; and
- Solel – now bought by Siemens, and showing interest in CSP steam turbine market.

Similarly, examples of companies involved in power tower developments include:

- Abengoa Solar / Abener;
- Bright Source Energy;
- Torresol; and
- eSolar.

For CPV, the only companies that have installed plants of greater than 1 MW capacity are Amonix, ENTECH, Guascor Foton and SolFocus.

Technology divisions could be owned by an energy company with construction subsidiaries. The aim of the subsidiaries would be to develop and construct projects using whatever technology is most likely to receive development permits, while being economically viable for the company.

Manufacturers of key specialist components are limited in number. Some of them include:

- Parabolic trough mirrors – Flabeg, Rioglass;
- Parabolic trough receiver tubes – Solel (now owned by Siemens), Schott;
- Steam turbines for CSP projects – the market currently appears to be dominated by Siemens.

7.5 Uncertainties and Risks

Large uncertainties remain for the future of CSP both in the short and long term. Some of the major uncertainties are summarised in this section.

7.5.1 Achieving Performance Improvements

Many of the projected cost reductions for CSP rely on achieving performance improvements in the technology. Uncertainties include:

- Extent of further improvements in alignment technologies;
- Increase in cost-effectiveness of heat transfer using different heat transfer fluids, or the limits heat transfer imposes on scale-up of project size; and
- Effective feedback from projects recently completed or currently under construction into new projects soon to commence construction, to enable successful technical developments and lessons learned to be incorporated.

7.5.2 Realising Learning Rate Effects

Projections for long term cost reductions for CSP rely to a large extent on learning rate assumptions. In order for these reductions to be realised there must be:

- Continuity of technical development;
- Sustained and continuous build rate, taking into account actual costs and economic support mechanisms which will be visible and bankable in future;

- Sufficient proportion of the value of the plant which can be expected to be subject to learning rate effects; and
- The percentage learning rate effect which is predicted must be realistic.

7.5.3 Supply Chain Competition

Cost projections for CSP often assume increasing competition in the supply chain. However, there is currently low diversity of supply of specialist components, and sustained

market volume will be required to attract new supply companies into the market.

7.5.4 Short Term Cost Uncertainties

Other cost uncertainties include:

- Commodity price variations; and
- Project development and construction cost uncertainties (typically greater than $\pm 30\%$) remaining once preliminary project design is defined.

8. CONCLUSIONS

For all CSP technologies in the foreseeable future, substantial economic support will be required for project economic viability, through a support mechanism specifically designed to support CSP projects. Hence the first requirement for bankability is the availability of such support, including commitment to provide revenue support at a defined level and for the period necessary to achieve appropriate project returns.

For utility scale power production, parabolic trough is considered to be the most bankable CSP thermal technology, due to its operational track record, which gives it a moderate technology risk (low relative to other CSP technologies). However, actual project construction costs are currently very high and show a very large range. The actual completion costs of projects currently under construction will be key to providing the basis for acceptable financial risk.

Power tower technology is considered to be the second most bankable CSP thermal technology based on operational experience of 44 MW projects over the last 1 to 3 years, and current project construction experience, which gives it a medium technology risk. As with parabolic trough, actual project construction costs are currently very high and show a very large range. The actual completion costs of projects currently under construction will be key to providing the basis for future financing.

Parabolic dish technology has been demonstrated at unit level for dishes of 25 kW capacity. However, the construction of a large array of dishes to form a commercial scale project has yet to be completed. Bankability of this technology in the short term will be reliant on the success of one technology and project developer partnership, namely Tessler / Stirling Energy Systems (SES), in taking its plans forward. There is insufficient actual construction experience to confirm costs at this stage.

Linear Fresnel technology and project development is currently being aimed at smaller-scale building-integrated, process steam, or desalination applications, although there are some technical developments currently being undertaken which could make it more competitive with parabolic trough for utility-scale generation. Until this is demonstrated pre-commercially, linear Fresnel technology is not considered bankable for utility-scale power generation. There is insufficient actual construction experience to confirm costs of utility-scale projects at this stage.

Concentrating PV is currently perceived as a relatively high risk investment compared to other solar technologies. Reasons for this include a lack of standardisation and certification, lack of volume production, and lack of an established supply chain with demonstrated capability. Financing risk may be reduced if CPV is installed alongside a mature technology such as flat plate crystalline PV in a hybrid installation.

Appendix B

AC Benchmarks

Table 1: Cable Specification

Manufacturer	XXX
Model	XXX
Conductor nominal cross-section	50mm ²
Core number	1
Conductor type	Rm
Insulation thickness	5.5mm
Sheath thickness	2.5mm
External diameter	33mm
Maximum conductor operating temperature	90°C
Nominal voltage U ₀	12 kV
Nominal voltage U	20 kV
Conductor material	Copper litz wire, bare
Core insulation	Cross-linked Polyethylene (XLPE) Suitable for outdoor use
Standards compliance	DIN VDE 0276 part 620, HD 620 S1 , IEC 60502

Table 2: Switchgear Specification

Manufacturer	XXX
Model	XXX
Insulation type	Gas Insulated Switchgear
Rated voltage	24 kV
Rated short-duration power frequency withstand voltage	50 kV
Rated lightning impulse withstand voltage	125 kV
Rated frequency	50 or 60 Hz
Rated peak withstand current	100 kA
Rated short-circuit making current	100 kA
Rated short-time withstand current, 3 s	40 kA
Rated short-circuit breaking current	40 kA
Rated normal current for busbar	5000 A

Table 2: Switchgear Specification

Rated normal current for feeders (depending on panel type)	2500 A
Degree of protection	IP 65
– Primary part	IP3XD
– Secondary part	
Dimensions (WxHxD)	600x1625x2350 mm
Warranty	2 years
type-tested switchgear	IEC 62 271-200
Standards compliance	IEC 60038, 60095

Table 3: Transformer Specification

Manufacturer	XXX
Model	XXX
	Indoor/Outdoor
Number of phase	3
Rating	1350 kVA
Primary side voltage	20 kV
Secondary side voltage	690V
Vector Group	Dyn5 or Dyn11
Cooling	Oil immersed hermetically sealed ON AN
Insulation type	NYNAS NYTRO TAURUS
Frequency	50 or 60 Hz
No load loss Po	1.700 kW
Impedance loss Pk	12.000 kW at 75°C
Short-circuit impedance uk	6%
Dimensions (WxHxD)	1860 x 1110 x 1830 mm
Weight	3800 kg
Oil weight	700 kg
Noise level	≤ 60 dB(A)
Protection system	DGPT2
Warranty	2 years
Standards compliance	IEC 60076, IEC 60085, IEC 60214

Appendix C

EPC Contract Model Heads of Terms

Definitions and Interpretation

EPC Definitions

- **Acceptance Date** – is the date that formal final acceptance of the Contractor's works by the Client takes place.
- **Building Permit** – means the building and planning permit which is attached to the Appendices.
- **Construction Period** – means the period commencing on the Effective Date and expiring on the Completion of the Project.
- **Contractor** – the EPC contractor.
- **Client Representative** – means a selected representative of the Client that reports/advises the Client.
- **Effective Date** – means the first day after the day on which the EPC Contract is signed.
- **Final Acceptance Report** – means the report to be signed in accordance with clause [xx] the form of which is set out in Exhibit [x].
- **Final Acceptance Test** – has the meaning given to it in Appendix [x].
- **Force Majeure Event** – means all unforeseeable events that lie outside the sphere of influence of the Parties (including unlawful delays in proceedings at the public authorities) and the effects of which on the fulfilment of this Agreement cannot be prevented by the Parties through reasonable efforts or alternative arrangements; such events or circumstances shall include, among others, extreme weather conditions at the Site that should not normally be anticipated at the time of conclusion of this Agreement. A Force Majeure Event does not include changes in prices of goods, materials, equipment, salaries and other items or any changes in general economic conditions.
- **Ground Studies** – means the ground studies commissioned by the Contractor at its own expense prior to the date of this Agreement in respect of the Site.
- **Independent Engineer** – means an independent engineer selected by the Lender(s) as of Financial Closing or thereafter and notified to the Contractor.
- **kWp** – means kilowatt peak.
- **Isc** – means the short circuit current
- **Nominal Power** – means the name plate nominal electrical output of the solar modules in kWp set out in respect of each module by the producer of the solar modules on the label placed on the module (save for manifest error).
- **Payment Schedule** – means the payment schedule in the form attached as Appendix [x].
- **Provisional Acceptance Report** – means the report to be signed which is set out in Exhibit [x].
- **Provisional Acceptance Test** – has the meaning given to it in Appendix [x]
- **VAT** – means value added tax or any equivalent tax that is levied on the supply of goods or services in any jurisdiction.
- **PAP** – Is the provisional acceptance period that is allocated for the acceptance test to reach the agreed values.
- **Plant** – The power plant to which this contract refers. Details of the power plant should be contained in an annex to the contract, including the total nominal power output (MWp), details of the equipment and systems that form the plant.
- **Principal** – Owner of the Plant.
- **Voc** – Open Circuit Voltage.

Subject and Purpose of the EPC Contract

- The Contract is for the Contractor to carry out the turnkey construction, commissioning and delivery of the Plant to the Client.
- The Contractor shall design and construct the Plant in accordance with the EPC contract, relevant international and national standards, industry best practice, OEM instructions, technical conditions set out in the Grid Connection Agreement and Power Purchase Agreement (or similar), and applicable legislation.
- The subject of this Agreement involves engineering, design, procurement, construction, assembly, testing, start-up, commissioning of the Project by the Contractor. The Project includes the construction and operation of the transformer station, connecting the power plant to the feeding point, to the transformer station, and connecting the power plant at the transformer station to the mean voltage system operated by [grid operator]. This includes switchgear (interface) as specified in Schedule of Scope of Work, on a turnkey basis with fixed term fixed price including fixed timeline and fixed performance.

Tasks and Obligations of the Client

General

- The Client shall be required to provide and maintain access to the site unless this is included within the Contractor's Scope of Work.

Site Data

- The Client shall make available to the Contractor any site data (already collected for the site) that has been requested by the Contractor before signing of the EPC contract.

Permits

- Prior to the date on which the Contractor shall commence site works, the Client shall obtain all necessary planning permissions, building permits,

authorisations for connection to the electricity distribution network. These permissions and authorisations will entitle the Contractor to carry out the construction and installation of the plant on the Site.

Inspections

- The Client shall have the right to have the construction works monitored by a representative of their own choice and on their own terms. The representative shall be independent and not affiliated to the Contractor in any way.

Alterations to Client Scope of Work

- All required alterations / deviations to the agreed scope of work by the Contractor costing over €/£/\$[xxx] shall require the approval of the Client or the Client's Representative.

Tasks and Obligations of the Contractor

General Scope of Performance

- The Client shall be provided with all appropriate site drawings/documentation before construction works begin on site.
- The Contractor shall deliver a Plant that operates within the following capacity and performance parameters:
 - A total capacity of not less than [x] kWp DC. The total capacity shall be defined as the total of all nameplate output capacities as indicated on each module installed.
 - At Provisional Acceptance, Plant Performance Ratio of greater than [x] %.
 - During the Acceptance Test Period, a Plant Availability of greater than [x] % during daylight hours.
- The Contractor shall be responsible for the completion of the works that are necessary to satisfy the requirements listed under the scope of the contract.

- The Contractor shall also be responsible for the safe and proper operation of the Works in conjunction with the works and services to be provided by the Client for the purpose of completing the Plant.
- The Contractor shall provide a guarantee for a duration of [x] years that the plant will contain all characteristics detailed within the EPC contract.
- For the duration of the site works, the Contractor shall be responsible for the provision of security/ surveillance of the Site and all goods, materials, equipment and other items located on the Site.
- The contractor shall conduct studies to satisfy themselves of the ground conditions on site.

Delay

The Contractor shall be required to complete the installation and construction of the plant in accordance with the timelines set out within the Project Schedule. If the Contractor is unable to complete the works within the agreed timescales, then the Contractor will be required to pay the Client compensation.

The contractor shall be required to pay the client €/£/\$xxxx per day of delay past the agreed completion date within the Project Schedule.

The amount of compensation that the Contractor will be obliged to pay to the Client as a result of failure to meet the timelines set out within the Project Schedule shall be limited to a maximum of [xx]% of the total value of the Contract.

Defects

The Contractor shall be responsible to the Client for any defects, including absence of any feature explicitly specified within the scope of works, and any failure relating to any guarantee of any component of the plant.

Permits

Prior to the date on which the Contractor shall commence Works on the Site, the Client shall obtain all necessary planning permissions, building permits and authorisations for connection to the electricity distribution network. This will be done in order to entitle the Contractor to carry out the construction and installation of the plant on the Site.

The Contractor is responsible for designing, constructing and the installation of the plant in accordance with all necessary planning permissions, building permits and authorisations for connection to the electricity distribution network that are in place and have been obtained by the Client.

Documentation

The Contractor shall provide the Client with all appropriate site drawings/documentation before construction works begin on the site.

The Contractor shall be required to provide, at a minimum, the following documentation after the final acceptance tests have been completed:

- Technical data sheets for all components / materials.
- 'Flash Lists' for the modules.
- Operation and maintenance manuals.
- Procedures for managing faults/malfunctions/issues.
- Characteristics of the components.
- Both general and detailed final 'as built' drawings.
- Inspection certificates from the respective competent governmental authorities and institutions, and any other documents that would be required for the operation of the Plant.
- All component guarantees / warranties.

The Contractor's Right to Employ Sub-contractors

To fulfil obligations arising from the EPC Contract, clauses are required to specify the entitlement of the Contractor to use competent third parties. The Contractor shall be fully responsible for the action of sub-contractors.

The Contractor shall only be allowed to appoint sub-contractors only after approval from the Client or the Client's Representative.

The appointment of sub-contractors does not relieve the Contractor of the responsibility for the complete, accurate and timely execution of the Contract.

Project Schedule

A project schedule shall be required to highlight the installation and construction timelines. It should also include, at a minimum, the dates for the tasks listed below:

- Commencement date

- Mounting frame installation dates
- Module installation dates
- Inverter installation dates
- Operation date
- Acceptance testing date
- Completion/Take-Over date

Payment Schedule

The Contract Price shall be a fixed cost for the complete delivery of the plant, and shall be calculated using the following formula:

Total installed capacity (kWp) x €/£/\$[xxxx]/kWp = contract price (excluding VAT)

Payments shall be made by the Client to the Contractor in accordance with a Payment Schedule that shall be contained within the Annexes of the EPC Contract. The payment Schedule and associated Milestones shall take the form as seen within Table 1.

Table 1 – Milestone Payments and Transfer of Title

Milestones	Definition of Milestone	% of Contract	Accumulated Payments
M1	Advance payment after signing of Contract	10	10
M2	100% mechanical and electrical completion of: <ul style="list-style-type: none"> • module support structures (tracking systems) • security fence • electrical substation 	20	30
M3	100% mechanical and electrical installation of the PV modules, and inverters.	40	70
M4	Payable after commissioning and availability of at least 90% of the modules	10	80
M5	Acceptance of the Provisional Acceptance Tests and issuance of the Provisional Acceptance Certificate. Completed scope of work and snag list.	10	90
M6	First receipt of income from generation (of power) on the site.	10	100

The Contractor shall not be entitled to payment for any milestone until all requirements of the milestone are met. The Client shall retain 10% of the contract until first receipt of income from generation (of power) on the site.

Testing and Sign Off

Pre – final Testing

Pre-final testing at a minimum shall consist of the following:

- Verification of the completeness of work.
- Voc and Isc for each string greater than [93]% of nominal – with $I > 600 \text{ W/m}^2$.
- Submission of:
 - Construction Progress Report.
 - Functional check documentation.
 - Statement of module installation completeness.
 - Snagging list as agreed by Contractor/Client.
 - Declaration of compliance to all local grid connection requirements.

Provisional Acceptance

The provisional acceptance test shall at a minimum consist of a provisional acceptance period (PAP) of [15] days, and shall have a guaranteed level of performance of:

- [xx]% efficiency (temperature and irradiation corrected) for the DC generation.
- [xx]% conversion efficiency.

Or

- [xx]% Performance Ratio (to grid export meter) with temperature and irradiation correction

The minimum documentation to be provided with the test report is as follows:

- Technical data sheets for components / materials.
- Operation and maintenance manuals.
- Procedures for managing malfunctions.
- Characteristics of the components.
- Both general and detailed final drawings.

Final Acceptance Certificate

The Final Acceptance Certificate shall have a guaranteed level of performance of:

- [xx]% PR (to grid export meter) with temperature and irradiation correction.
- During the period between Provisional Acceptance and Final Acceptance an average availability during daylight hours of greater than [xx]%.

And following a period of [x] month(s) following the provisional acceptance test, the test is repeated with the following level of performance to be achieved:

- [xx]% efficiency (temperature and irradiation corrected) for the DC generation.
- [xx]% conversion efficiency.

Or

- [xx]% Performance Ratio (to grid export meter) with temperature and irradiation correction

Make Good Periods

If the Plant does not meet the guaranteed levels of performance set out in the Pre-Final, Provisional Acceptance or Final Acceptance tests, the Contractor has [x] days to make good the deficiencies. Retesting of the Plant will be at the

Contractor's expense, including the costs for any external/ third party testing experts. If the Plant does not achieve the guaranteed levels of performance even after repair and retests, then the Contractor shall either make compensation to the Client or the Client will be entitled to withdraw from the agreement. [Note: This clause needs to be carefully worded and agreed between the Client and Contractor. Even small deficiencies in performance can add up to large reductions in revenue over the project lifetime.]

Warranty

The Contractor warrants that their work will remain defect free for a period of [x] years following final acceptance of the Plant.

The Contractor will transfer all equipment warranties and guarantees to the Client following Final Acceptance.

Legal, Governing Law and Jurisdiction

The contract shall have sections covering:

- Governing law and court of jurisdiction of the agreement. The governing law is normally the law of the country in which the Plant is located.
- A legal succession or a transfer of rights condition is required so that the Principal reserves the right to assign the EPC contract to a third party.
- Non-disclosure agreement. This agreement between the Contractor and the developer will outline what information is to be considered confidential and what may be disclosed to third parties.
- Contractual language. Defining the language in which the official legal contract and agreement are to be drafted.
- Agreed language for the delivery of reports, documentation and accounts and which version will be the legal copy.

Insurance

The Contractor shall have, at a minimum, the following insurance cover for the duration of the site works:

- Erection Insurance
- Public Liability Insurance
- All Risks Insurance

The contractor shall also, at their own expense, be required to hold any other legally required insurance for the location of the Plant.

Duration and Termination of Agreement

Sections required for covering:

- Commencement of the agreement
- Standard duration of the agreement
- Extension of the agreement (at the option of the Principal)
- Termination of the agreement due to:
 - Financial arrears.
 - Insolvency.
 - "Good cause" relating to statutory law, failure to comply with the requirements contained in this agreement, or environmental, planning or legal breaches.
- Consequences of the termination.

Arbitration

Sections required for covering:

- The settlement of any dispute that might arise concerning the EPC Contract.
- Notification of arbitration.
- Location of the arbitration hearing and under what law.

Communications

Sections required for detailing how communications shall be conducted between the Client and Contractor, including language and acceptable channels of communication.

Contact details for both the Client and the Contractor's representatives shall be included within this section.

Applicable Law

Sections are required for:

- Stating the law (depends on the location of the plant) that the agreement shall be governed by.
- Both parties to expressly declare acceptance of all the terms and conditions contained in the EPC Contract signed by them.

Appendices to the EPC Contract

Within the contract, reference will be made to a number of stand-alone documents, which will form an integral and fundamental part of the contract.

These documents may include the following:

1. Site Plans [this should include all layout plans for the proposed plant]
2. Scope of Work

3. The Project Permits [Planning / Building / Grid Connection]
4. Form of the Progress Report
5. Training of Personnel
6. Construction Schedule [this should include all the timelines for the construction tasks for the plant]
7. Payment Schedule [this should include all the agreed milestone payments for the project]
8. Energy Yield Study (Yield Assessment Report)
9. Performance Ratio
10. Performance Bond
11. Warranty Bond
12. Parts of the Project to which the Structure Warranty applies
13. [module manufacturer] Documents
14. Module Warranty Terms & Conditions
15. Sub-contractors [this should include a list of approved sub-contractors that are allowed to complete work on the plant]
16. Provisional Acceptance Test and the Final Acceptance Test [this should include the test requirements that are planned to be done on the Plant]
17. Form of the Work Completion Certificate, Provisional Acceptance Report and the Final Acceptance Report
18. Form of the Protocol
19. Form of the Completion Report
20. Form of the Site Hand-over Protocol

Appendix D

O&M Contract Model Heads of Terms

Definitions and Interpretation

- **Annual Report** – the report to be provided by the Contractor annually during the term of the O&M contract.
- **Availability** – means the availability of the Plant to feed electricity into the grid.
- **Availability Contractual Penalty** – the penalty imposed if the plant fails to reach its contractual availability.
- **Contractor** – the O&M Provider.
- **Guaranteed Average Availability** – the guaranteed average availability of the plant for power generation during a specified time period and conditions as defined in the contract.
- **Guaranteed Response Time** – is the time taken to resolve faults, and is dependent on the nature of the fault and its impact on the total output of the project.
- **Maintenance** – the execution of all operations, required to maintain the functioning of the Plant in accordance with the agreed maintenance schedule.
- **Measured Average Availability** – the actual average generation availability of the Project. This is measured and calculated as defined in the contract.
- **Normal Performance** – defined as performance within [5%] of the Performance Ratio as defined in Appendix [x].
- **OEM** – Original Equipment Manufacturers. For example, the manufacturers of the modules, inverters, mounting system, security system and medium voltage electrical systems.
- **Plant** – the power plant to which this contract refers. Details of the power plant should be contained in an annex to the contract, including the total nominal power output (MWp), details of the equipment and systems that form the plant.
- **Principal** – Owner of the Plant.
- **Repairs** – the implementation of all works required to restore the function of the Plant following damage or failure.

Subject and Purpose of the O&M Contract

- The Contract covers the technical monitoring, performance monitoring, maintenance and repair of the Plant, and associated activities.
- Access to the Plant shall be provided by the Principal to the Contractor.
- The Contractor shall be properly trained and well acquainted with the Plant.
- The Contractor shall maintain the Plant in accordance with the O&M contract, O&M Handbook, OEM instructions, technical conditions set out in the Grid Connection Agreement and Power Purchase Agreement (or similar), and applicable legislation.
- The Contractor will maintain the plant as defined in the definition and annex [x]. This will include (but not necessarily be limited to):
 - DC Generation components (modules, cables, mounting structures)
 - AC Generation components (inverters, cables, transformers, MV switchgear)
 - Monitoring Systems [monitoring generation of power, climate (irradiation, wind, temperature), security, video control system (CCTV)]
 - Site in general (vegetation control, road and site access, security fence and gates, buildings)

- The Contractor shall maximise the output of the Plant in both the short and long term by monitoring and rectifying disruptions, and enable the Plant to adhere to the Minimum Availability parameter.
- The Contractor is to provide periodic reports and advise on technical issues during operation.
- The Contractor shall maintain the Plant to ensure that the degradation of the Performance Ratio is not more than [1%] per year [as defined in the Acceptance Test]
- The Contractor shall operate and maintain the Plant such that warranties under the EPC contract are not restricted and remain enforceable.

Tasks and Obligations of the Contractor

Operation of the Project

- The Contractor shall:
 - Operate the Plant on behalf of the Principal, and ensure uninterrupted operation (wherever possible) and optimal usage of the Plant, subject to the weather conditions.
 - Advise the Principal on all significant issues relating to the operation of the Project.
 - Make sure that the Principal has unlimited right to inspect the Plant and perform works on it.

Maintenance

- The Contractor shall maintain the Plant in accordance with the Maintenance Schedule (contained as an annex to this agreement). The Maintenance Schedule will show the minimum maintenance required and minimum frequency for each item per annum.
- The Contractor shall carry out a minimum of [two] maintenance inspections per year. This shall

include the assessment of the condition of the Plant including (but not limited to) the following:

- Condition of the generation equipment and supporting structures.
- Functional check and condition of the security systems.
- Visible damage and defects including functional check of safety equipment.
- Inspection of the medium voltage components (up to the grid metering point).
- The Contractor shall, as a minimum, maintain Plant components in order to comply with their warranty conditions.
- The Contractor shall remove snow and other accretions (dust and dirt) from the modules as required.
- The Contractor shall keep the Site free from undesirable growth of plants and shrubs, to achieve the best possible energy yields. Green areas shall be mowed and waste materials removed. Dust shall be kept to a minimum to reduce soiling. Vehicles and machines will be used such that they do not damage plant components.
- The Principal shall pay the cost of electricity and water required for maintenance purposes (within the boundaries of the Plant)—and not expressly covered by another clause within this agreement.
- The Contractor shall maintain the Plant so that the degradation of the Performance Ratio is not more than [1%] per year, and shall inform the Principal if this limit is likely to be exceeded.
- The Contractor shall perform specialised cleaning as required, on a site-specific basis to avoid seasonal dust and dirt accumulation.
- All maintenance work that may affect the energy generation of the Plant, will be carried out, as far as reasonably possible, during low-irradiation periods.

Monitoring of the operation / analysis of the data / switching off of the Plant

- The Contractor shall:
 - Monitor the operation of the plant and feed-in capacity, without interruption, 365 days a year, 24 hours a day. This will be done using remote data monitoring systems which will be maintained and updated by the Contractor.
 - Set right faults that can be rectified remotely. This shall be done as soon as possible and within [1] day. All other faults shall be rectified within the Guaranteed Response Time.
 - Check and assess the data collected on a daily basis, and compare the readings with the assumed targets, by referring to the following functions and operations:
 - DC Component Availability.
 - AC Component Availability.
 - Irradiation.
 - Generation (kWh).
 - Network availability.
 - Function of the Security System.
 - Performance Ratio.
 - Faults and Response Logs.
 - Manage and maintain the operational monitoring and data recording system in a secure and permanent manner.
 - Be obliged to switch off the Plant within [1] day if the operator of the Grid System requires.
- The Principal shall have unrestricted access to read the remote monitoring data.

Failure Messages and Reaction Time

- The Contractor shall monitor the Plant in accordance with this agreement. In the event of a malfunction occurring in one of the functions monitored, a failure message will be sent to the Contractor.
- The Contractor is obliged to take all reasonable measures necessary to rectify any malfunction notified by a failure message, or detected through an inspection, as soon as possible to restore the functionality of the Plant.
- The Contractor is obliged to acknowledge and react to failure messages, depending on the severity of the failure or malfunction, as shown below:
 - The Contractor is obliged to acknowledge the failure message within [1] calendar day.
 - If the failure has a low impact on the yield loss of the Plant [$<5\%$] per calendar day, then the Contractor will commence and conclude measures to resolve the problem within [14] calendar days of having received the failure message.
 - For other failures in the Plant, the Contractor will commence measures to remedy the malfunction within [24] hours after having received the failure message.
 - Where relevant spare equipment is available on site or within the Contractor's control, the repair will be completed within [36] hours of receipt of the failure message.
 - Where spare equipment is not available on site or within the Contractor's control, the Principal will be informed and updated on the repair options, progress and return to service date. The Contractor will order the spare parts within [one] business day and carry out the repairs, if and when the parts become available, within the Guaranteed Response Time.

Repair

- The Contractor is responsible for repairs in order to bring the Plant to fault-free operation.
- The Contractor is to correct defects that become known through technical monitoring, and visual and functional checks.
- The Contractor is to replace damaged components, or parts that are causing disruption to the operation.
- In cases where material and spare parts are required by Contractor, the amount will be paid by Principal without the need for prior approval, provided the value does not exceed [USD 1500] within a [six] month period.
- Approval in writing is to be sought from the Principal for repairs (including material and spare parts) that are expected to exceed [USD 1500] within a [six] month period.
- The Principal shall approve the cost of repairs within [3] business days.
- The Contractor is to keep a spares stock of particularly susceptible components.
- Spare parts, tools, measurement and test equipment are the responsibility of the Contractor.

Materials and Lubricants

- The Contractor will provide under this agreement all consumables, small items, and lubricants (with a value less than [x]) required for the maintenance, inspection and repairs without charge.
- The Contractor guarantees that all parts to be delivered and installed within the scope of this agreement will correspond to the parts being replaced, with respect to functionality and durability.
- The Contractor is responsible for the removal and disposal of old parts, lubricants, packaging as required by the relevant laws and regulations.

- The Contractor gives an assurance to keep parts available to PV plant experts or for inspection by insurance advisors/estimators whenever an insurance claim is made.

Documentation and Reporting Obligations

The Contractor is to provide the following reports:

- Monthly reports describing the availability, day by day production, performance ratio, irradiation measurements, faults and maintenance or repair activities that are conducted on the Plant.
- Quarterly reports describing material events (that occurred or are expected to occur) such as maintenance tasks and repairs, a schedule for repairs and maintenance, a stock list of spare parts and consumables, and a description of availability, irradiation, Performance Ratio and downtime.
- Semi-annual inspection reports documenting the visual and function checks with photographic evidence of observed issues.
- Annual reports for each year of the contract period giving:
 - A summary of repairs and maintenance tasks completed.
 - Parts and consumables used for repairs and maintenance, and total cost thereof.
 - A summary of performance and operation: monthly availability, Performance Ratio and production.
 - A summary of plane of array irradiation measured on Site.
 - The annual Performance Ratio and a comparison of production with irradiation-corrected target values given by the energy yield prediction.
 - Forecast of scheduled maintenance.

- Reports on significant disruptions, damage or defects.

Commercial Operation

- The Contractor will check and verify the accounts with the energy supplier and energy off-taker in accordance with the Power Purchase Agreement.
- The Contractor shall check invoices that have been received by the Principal from third parties—in the course of the operation, maintenance and repair of the Plant—for plausibility and accuracy.

Defect and Insurance Claims

- The Contractor is required to inform the Principal about possible and actual defects in the Plant for which the Principal may have Warranty claims under the EPC Contract or under other agreements that the Principal may enter into in respect of the Plant as soon as it gains knowledge of such defects.
- The Contractor's own works, equipment, spare parts and materials provided should be covered by warranty for a period of [2] years.
- The Contractor will provide full support to the Principal in communication with insurance companies for matters related to the Plant.

In the event that the Contractor cannot remedy the defects or fails to redress or make good any defect as soon as possible, the O&M contractor shall pay the Principal damages to compensate the loss incurred (including loss of profit).

Carrying out the operational management in compliance with the applicable laws and using professional personnel

- The Contractor should be required to ensure that the Plant is operated and maintained in compliance with the applicable laws and contract supporting

documents (for instance, O&M handbook, relevant permits, consents and licences).

- The Contractor ensures that suitably qualified, experienced and accredited personnel will be used for each task.

Security

[Depending on the requirements of the Principal, the Contractor may be made responsible for the security arrangements for the Plant. If so, the requirements for monitoring and maintaining the security system—and the costs of providing these services—should be contained in the agreement]

- Security to be provided and monitored 365 days/year for 24 hours/day.

Warranty and Liability

Warranty Period

- The Contractor warrants all respective maintenance work undertaken in accordance with this agreement. Guarantee is also given for operations to remedy any agreed failures for a period of cover of [three] years from the time of the work.

Replacement of Parts

- The Contractor provides a three-year warranty for any replacement of parts and components provided and installed under this agreement.

Guaranteed Availability

- The Contractor is to ensure that the Measured Average Availability in each generation period equals or exceeds Guaranteed Average Availability figures in the following manner:
 - Guaranteed Average Availability for each [twelve] month Generation Period of this agreement will be in excess of: 97%

- The Measured Average Availability shall be calculated according to the following formula:
 - $\text{Measured Average Availability} = \frac{\text{Grid-connected available hours}}{\text{possible available hours}} * 100\%$.
 - Grid-connected available hours are the number of hours that the inverters are connected to the grid and available for export of power. In effect, it also means the number of daylight hours (which are to be defined) during which the Plant is able to convert irradiation into energy. Importantly, availability outside daylight generation hours is not to count towards the grid connected availability hours.
 - Possible available hours need to be defined (taking leap years into account). It should exclude hours allowed due to a) defined periods of planned maintenance (e.g. [x] hours per year in winter months, [x] hours per year in summer months) and b) hours when the Plant was not available as a result of Force Majeure events.
- If the Measured Average Availability for a generation period is less than the relevant Guaranteed Average Availability for a generation period, the Contractor shall pay an Availability Contractual Penalty [rate of penalty and calculation to be agreed].

Liability

It is important to specify the equations for calculation of the liability due to low availability and the maximum cap on liability besides outlining the method and timing for the Contractor to reimburse the Principal. These reimbursements may take the form of financial payments to compensate for the generation losses, or reductions in the remuneration to the Contractor (under the O&M agreement) in the subsequent term.

- Liability should be limited to the loss of earnings of the Principal, taking into account any payments that are made by the insurance cover or other warranties on the Plant.

The Contractor's right to employ sub-contractors and the Principal's right to instruct third party contractors

Clauses are required to specify the entitlement of the Contractor to use competent third parties to fulfil obligations arising from this O&M Contract. The Contractor should be fully responsible for the action of sub-contractors.

Often, the Principal has the right to refuse the use of third parties. However, this should be expressly covered in this agreement.

Obligations of the Principal

These will include:

- The creation and upholding of the legal pre-requisites for the operation of the Plant
- The provision of documents and information necessary for the operational management of the Plant and fulfilment of the Contractor's obligations.
- Granting rights of access to the Plant, grounds and buildings inside the Site (as required for the execution of this agreement) at all times.

Remuneration

The cost and remuneration of the O&M contract will be broken down into:

- Fixed Remuneration
 - Paid by the Principal based on an annual fixed lump sum per kWp of installed nominal capacity (as defined in the EPC contract).
- Reimbursement of expenditure and remuneration for other services not included in the fixed remuneration, and invoiced separately at agreed prices:
 - Spare parts and components that are approved in advance by the Principal and are required for maintenance and repair. This will not include

parts that are subject to warranty claims, or minor repairs of value less than [x].

- Services and ancillary costs that are approved in advance by the Principal and are required for maintenance and repair. This will not include services that are due to parts that are subject to warranty claims, or minor repairs of value less than [x] that are to be corrected during semi-annual inspections.
- Agreement is to be made on the invoicing dates/frequency and payment terms for the Principal.
- Agreement is to be made on the indexation of the remuneration over the term of the agreement. Often this is linked to a consumer price index, power purchase or tariff increase or inflation index.

Exclusions and work outside the agreement

- Exclusions to the availability guarantee and agreed remuneration, including maintenance or repair work that are caused by:
 - “Acts of God”
 - Extreme weather effects
 - Improper influence of the Principal
 - Third parties not attributable to the Contractor on the Plant
- Work covering these exclusions will be decided upon between the Principal and Contractor at the rates for additional work agreed in this agreement.
- Work outside the agreement including repair work undertaken within the scope of the insurance policy. In this case, the Contractor will carry out work as agreed with the insurance company and Principal. Costs will be agreed within the insurance terms and additional costs agreed with the Principal.

Legal, Governing Law and Jurisdiction

The contract should have sections covering:

- Governing law and court of jurisdiction of the agreement. The governing law is normally the law of the country in which the Plant is located.
- A legal succession or a transfer of rights condition is required to reserve the Principal’s right to assign the O&M contract to a third party.
- Non-disclosure agreement. This agreement between the Contractor and the Developer will outline what is to be considered confidential and what information may be disclosed to third parties.
- Contractual language. Defining the language that the official legal contract and agreement would be drafted in.

Agreement on the language for delivery of reports, documentation and accounts, and the version for the legal copy.

Insurance

The contract should also have a section outlining the insurance responsibilities of the Contractor for the operations and maintenance activities. This insurance should cover damage to the plant as well as provide cover for employees conducting the maintenance.

It is also normal for the Contractor to arrange and pay insurance for the full site. The agreement should contain full details and remuneration requirements, while the annex to the contract should include the insurance documentation.

Duration and Termination of Agreement

Sections covering:

- Commencement of the agreement
- Standard Duration of the agreement. [This is often for a 5-10 year period.]
- Extension of the agreement (at the option of the Principal)
- Renegotiation of the terms of the agreement following the expiration of the EPC Warranty. [After the expiration of the EPC warranty, the Contractor or the Principal may choose to renegotiate the terms of pricing, provision of O&M or support services, based on the past performance of the plant and the existing O&M agreement. The O&M contract is terminated if concurrence cannot be reached on the renegotiation of terms.]
- Termination of this agreement may also happen due to:
 - Financial arrears.
 - Insolvency.
 - “Good cause” relating to statutory law, failure to comply with the requirements contained in this agreement, or environmental, planning or legal breaches.

Communication

A section is also required to describe the pre-conditions for maintaining efficient and acceptable channels of communication between the Contractor and the Principal.

There should also be details of the representatives of the Principal and Contractor.

Appendices to the O&M Contract

Within the contract, reference will be made to a number of stand-alone documents, which will form an integral and fundamental part of the contract.

These documents may include the following:

1. Description of the Plant
2. Schedule of Maintenance
3. Insurance Cover
4. Sample Test Report [This should include all the tests that are planned to be done on the Plant.]
5. Draft Annual Report [This should detail the outline of the report that will be issued on a yearly basis.]
6. Price list [This should contain staff charge out and expense rates, the agreed rates for any components and/or the mark up and transportation costs for the items.]
7. Technical Connection Conditions [This will include all technical conditions imposed upon the Plant, including any imposed by the grid operator.]
8. Draft O&M Handbook
9. Form of O&M Handover Protocol [This should be a form detailing the agreed handover procedure.]
10. Energy Yield Analysis [This will be a copy of the energy yield study that should have been completed by an independent company and accepted by both parties.]

Acknowledgements: Alexios Pantelias, Hemant Mandal, Patrick Avato, Matt Willis, Anjali Garg, Naomi Bruck

Contact Information

Maruti Suzuki Building
3rd Floor, I Nelson Mandela Road,
Vasant Kunj, New Delhi - 110070
India
T: +91 11 4111-1000
F: +91 11 4111-1001
www.ifc.org

