

# LED Replacement Light Source

## - Technical topics

## - open items 2020-05

- In general for UN approved light sources
- OEM situation and AFTM situation
- Requirements clustered in
  - Safety
  - Performance
  - Consumer / Customer

### CONSUMER / CUSTOMER REQUIREMENTS

- E.g. higher lifetime specifications
- E.g. heavy duty performance
- E.g. limited color coordinates

### PERFORMANCE REQUIREMENTS and TEST METHODS (IEC 60810)

- Technical
  - Minimum lifetime
  - Minimum vibration resistance
- Information / Communication
  - Restricted white
  - ...

### SAFETY REQUIREMENTS (UN ECE)

- Technical
  - Luminous flux incl. tolerances
  - Maximum power
  - "Geometry"
  - ...
- Information / Communication
  - Rated voltage (and wattage)
  - Category name

# LED Replacement Light Source (LEDr) acc. to R37

- Photometric parameters
  - Same as for LED Substitutes
- Electrical parameters
  - Voltage range
  - FailureDetectionSystem-compatibility
  - PWM operation
  - EMC
- Mechanical parameters
  - Size
  - Mass
- Thermal parameters
  - Behavior under high ambient T.

Task for TFSR



## CONSUMER / CUSTOMER REQUIREMENTS

- ...

## PERFORMANCE REQUIREMENTS (IEC 60810)

- Technical
  - ...
  - ...
- Information / Communication
  - ...
  - ...

## SAFETY REQUIREMENTS (UN ECE R37 / RE5)

- Technical
  - ...
  - ...
- Information / Communication
  - ...
  - ...

# Electrical

Nr	Topic	Question	
#1	Voltage range	Does the LEDr have the same voltage - flux behavior as the filament light source?	done (TFSR-08-03rev4)
#2	PWM operation	Does the LEDr flicker in case of pulse-width modulation (PWM) operation?	→ TFSR-11
#3	Power / electr current	Does the LEDr cause a wrong failure message in the dashboard when it is working correctly?	done (TFSR-08-03rev4) →GRE-83 to decide on the 2 options
		Possible interaction with other electronics	
#4	EMC / EMI	Does the LEDr cause EMC problems in the vehicle?	done (TFSR-08-03rev4)
#5	Electrical robustness	Is the LEDr as robust against electrical disturbance as the filament lamp?	done (TFSR-08-03rev4); (→ IEC)
#5A	Polarity		done (TFSR-08-03rev4)

# Mechanical

Nr	Topic	Question	
#1	Vibration / Mass	Does the LEDr have the same mass as the filament lamp and is it as robust against vibration as the filament lamp?	done (TF SR-08-03rev4) (→ IEC)
#2	Maximum geometry	Does the LEDr have the same geometry / maximum outline as the filament lamp? Is the sealing affected by the geometry of the heat-sink	done (TF SR-08-03rev4)

# Thermal

Nr	Topic	Question	
#1	1min / 30 min ratio	Could it happen that the LEDr has higher intensity in the beginning (when switched on) and will reduce its intensity significantly as it reaches steady-state temperature?	done (TFSR-08-03rev4)
#2	High ambient temperature	Could it happen that the LEDr has significantly reduced intensity when it is operated at high ambient temperature?	→ TFSR-11
#3	Low ambient temperature	Could the de-icing / de-fogging behaviour of a luminaire be different when an LEDr is used?	Waiting for test results
#4	Cap temperature	Could the lamp cap get hotter with an LEDr compared with a filament lamp and could this lead to damage of the material of the luminaire?	→ TFSR-11

# Colorimetric

Nr	Topic	Question	
#1	Spectral content	<p>In signalling applications with coloured lenses, is the spectral content of the LEDr sufficiently like the spectral content of the incandescent lamp?</p> <p>e.g.</p> <ul style="list-style-type: none"><li>• Red lens</li><li>• Amber lens</li><li>• Green+red = white</li><li>• Green+red=amber</li></ul>	→ TFSR-11
#2	Minimum red content	Is the minimum red content fulfilled? (for RID applications).	done (TFSR-08-03rev4)

## Electrical #2

### - PWM operation

#### Question:

Does the LEDr flicker in case of pulse-width modulation (PWM) operation? Also covering PWM dimming for dual-function operation

#### Answer:

There are two application cases:

1. PWM for dual function dimming (tail / stop and FrontPos / DRL)
2. PWM for stabilisation (reduce voltage peaks))

→ 1) Dual function is only used for a limited number of categories: e.g., P21W, but not e.g. H7

→ 2) all LEDr are tested for “no visible flicker”

Status after TFSR-08:  
Discussed and agreed,  
technical details to be  
confirmed

CONSUMER / CUSTOMER REQUIREMENTS

PERFORMANCE REQUIREMENTS (IEC 60810)

SAFETY REQUIREMENTS (UN ECE R37 /RE5)

- Technical requirements for PWM-dimming-curve equivalent to filament behavior; dimming range up-to 10:1; PWM range 100 to 200 Hz; square wave
- Technical requirements for PWM operation at 100 Hz, 90% duty-cycle → no visible flicker, square wave

e.g. P21W

e.g. H7

# PWM for stabilisation

Investigations on popular European vehicle models have shown:

- PWM is used in many vehicles to stabilize the voltage when the alternator is charging the battery
- The most typical operation mode is:
  - 100 Hz
  - 90% duty cycle

According to CIE TN-006:2016 under these PWM operation conditions, there will be no significant visible effect for LEDs.

Nonetheless, interferences between the PWM signal and non-suitable light source electronics might lead to visible low-frequency effects or malfunction. This shall be checked by the test house during type approval.



# Electrical #3

## - Failure detection system compatibility

### Question:

Does the LEDr cause a wrong failure message in the dashboard when it is working correctly?

Does the LEDr cause a correct failure message in the dashboard when it has failed?

Incl presence detection (Kaltüberwachung)

### Answer:

Failure detection is mandatory for direction indicators (DI)

→ 1) LEDr for DI – The electronics of the LEDr is designed to ensure compatibility.

→ 2) user information for non-DI application (optional failure detection)

Initial proposal to  
TFSR-08  
Solution A

e.g. PY21W

e.g. H7

CONSUMER / CUSTOMER REQUIREMENTS

PERFORMANCE REQUIREMENTS (IEC 60810)

SAFETY REQUIREMENTS (UN ECE R37 /RE5)

- Technical requirements for minimum current / power : in case LEDr is working correctly. The limit should be >[50]% of the filament current; use of optional external electronics allowed
- Technical requirements for maximum current / power : in case LEDr is failed (no light emitting).; use of optional additional electronics needs to be discussed
- Information / Communication
  - The consumer is informed about the possible impact of the LEDr on the failure detection system and is given additional information / advice

## Electrical #3

### - Failure detection system compatibility

#### Question:

Does the LEDr cause a wrong failure message when it is working correctly?

Does the LEDr cause a correct failure message when it has failed?

Is the LEDr compatible with presence detection (“Kaltüberwachung”) ?

#### Answer:

For all LEDr the electronics of the LEDr is designed to ensure compatibility.

There shall be no light in the first 2ms.

Discussion during  
TFSR-08:  
Solution B  
„high power option“

CONSUMER / CUSTOMER REQUIREMENTS

PERFORMANCE REQUIREMENTS (IEC 60810)

SAFETY REQUIREMENTS (UN ECE R37 /RE5)

- Technical requirements for minimum current / power : in case LEDr is working correctly. The limit should be >[50]% of the filament current; use of optional external electronics allowed
- Technical requirements for maximum current / power : in case LEDr is failed (no light emitting)
- Information / Communication
  - The consumer is informed about the possible impact of the LEDr on the failure detection system and is given additional information / advice

# Failure detection system compatibility (non-DI) – two options

## Solution A- “high power AND lower power” versions

- „High power“ version for vehicles with failure detection (~[20]% of vehicles for low beam)
- „Low power“ version for vehicles without failure detection and for vehicles with low threshold (~[80]% of vehicles for low beam)
- User information

### Benefit:

- reduction of electronic waste by avoiding additional electronics
- optimized energy efficiency

-> reduced CO2 emission, reduced waste

### Disadvantage:

- Increased complexity for the consumer

### “mis-use”:

Wrong failure message in case of using a “low power” version where a “high power” version is needed “ (but the light source is working correctly)

## Solution B- only a “high power” version

- Only high power version

### Benefit:

- Less complexity for the consumer

### Disadvantage

- Increase of electronic waste by adding additional components where they are not necessary
- Artificially increased power consumption where low power consumption could be enabled

-> increased CO2 emissions, increased waste

Discussion during  
TFSR-08

# Option A: Two versions

## Consequence:

- Avoid unnecessary “electronic waste” (in total: 75% less waste)
- optimize energy efficiency (in total: 40% less energy / CO2)
- Consumer information needed

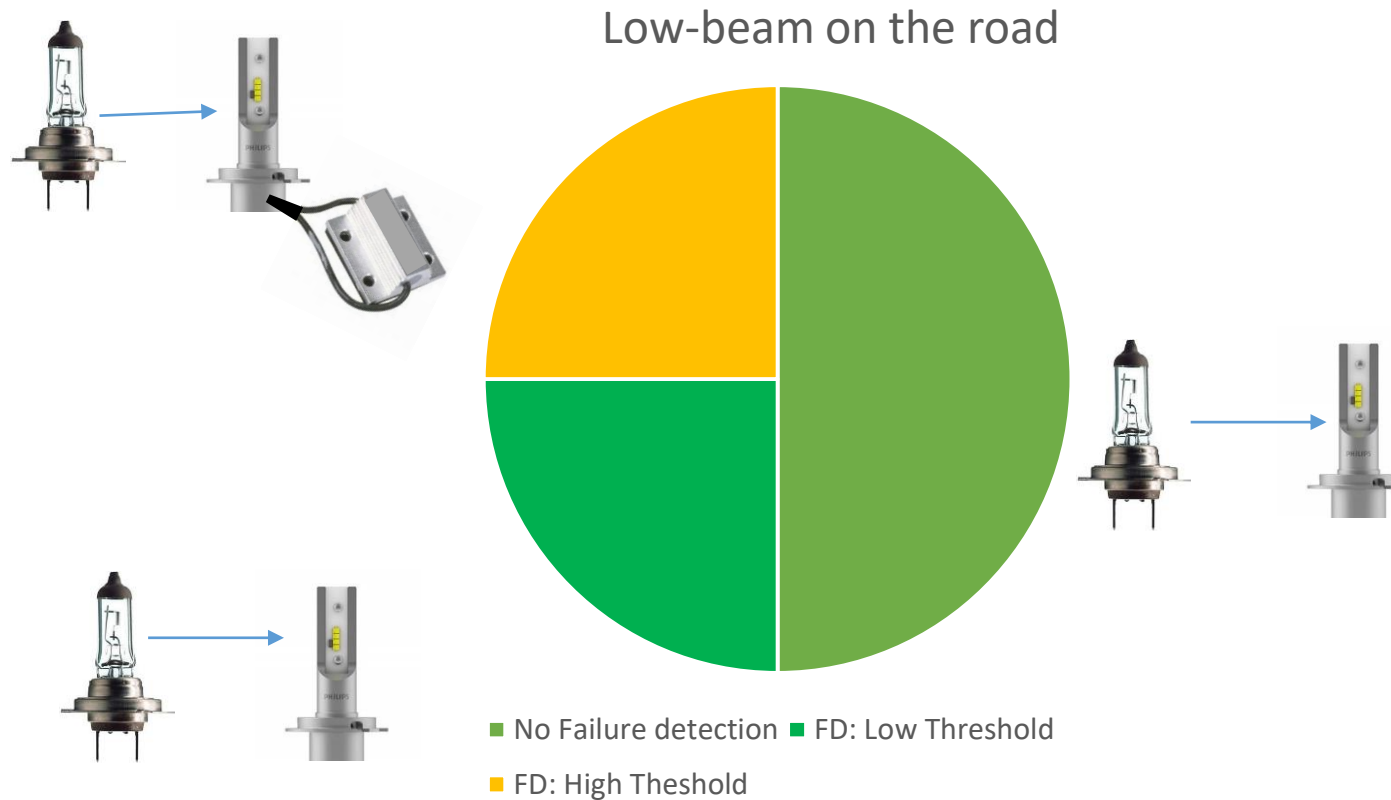

# Option B: One versions

## Consequence:

- unnecessary “**electronic waste**” (in total: 3 times more waste)
- Artificially **increased energy** consumption (in total: 60% more energy / CO2)
- No consumer information needed

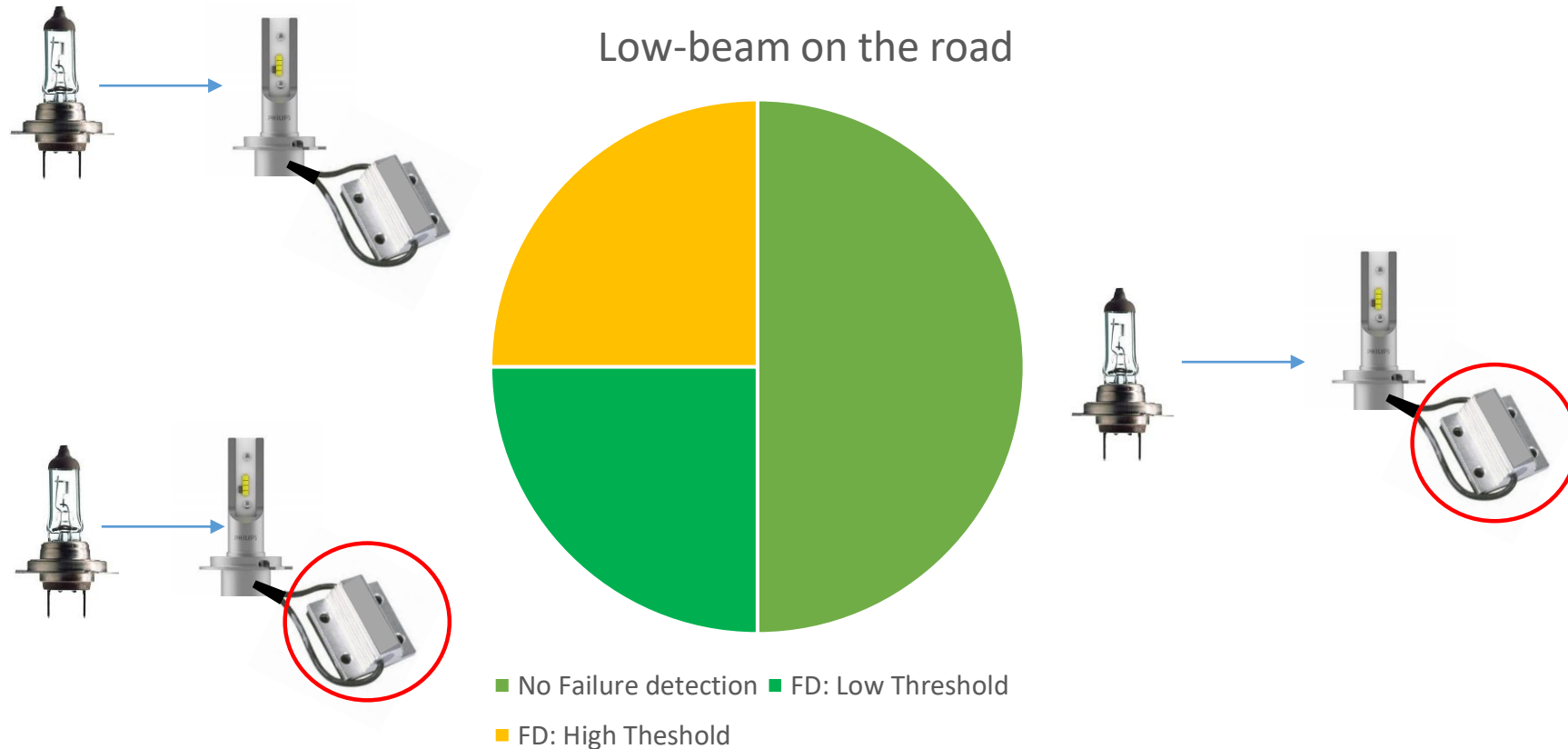

# Failure detection compatibility

In order to find the correct minimum current/power level for the LEDr, that is necessary to be compatible with failure detection systems of the vehicles (if present), measurements on a selection of the top selling European cars have been done.

Here a summary of measured threshold currents and a proposed RE5 requirement for the “high power” version

Results 2020 -05:

	Low beam e.g. H7	Direction Indicator e.g. PY21W
#1	540 mA	150 mA
#2	1700 mA	500 mA
#3	800 mA	275 mA
#4	1600 mA	800 mA
#5	450 mA	150 mA
#6		100 mA
#7		715 mA
<b>Maximum value found</b>	<b>1700 mA</b>	<b>800 mA</b>
Typical LED current („low power“ version)	1300 mA	500 mA
Proposed minimum current draw for „high power“ version	2000 mA	1000 mA

## Electrical #5A

### - polarity

#### Question:

Does the LEDr need a specific polarity (+ / -)?

#### Answer:

The LEDr should either work with both polarities or should be designed to withstand a wrong polarity without damage



CONSUMER / CUSTOMER REQUIREMENTS
PERFORMANCE REQUIREMENTS (IEC 60810) Requirement to withstand "reverse voltage"
SAFETY REQUIREMENTS (UN ECE R37 /RE5) LEDr shall be tested with both polarities, unless a. the polarity is specified in the category sheet (e.g. H4, P21/4W), or b. the light source can be inserted/connected in both polarity orientations (e.g. W5W, C5W) Unless specified otherwise in the category sheet. → An H11 and P21W need to work and be tested in both polarities

## Thermal #2

### - High ambient temperature

#### Question:

Could it happen that the LEDr has significantly reduced intensity when it is operated at high ambient temperature?

#### Answer:

LED-technology has a temperature-dependent behaviour. Additional tests are defined to ensure that there is no significant reduction of luminous flux.

The “real-world” temperatures show a function-, vehicle- and climate-specific statistical distribution.

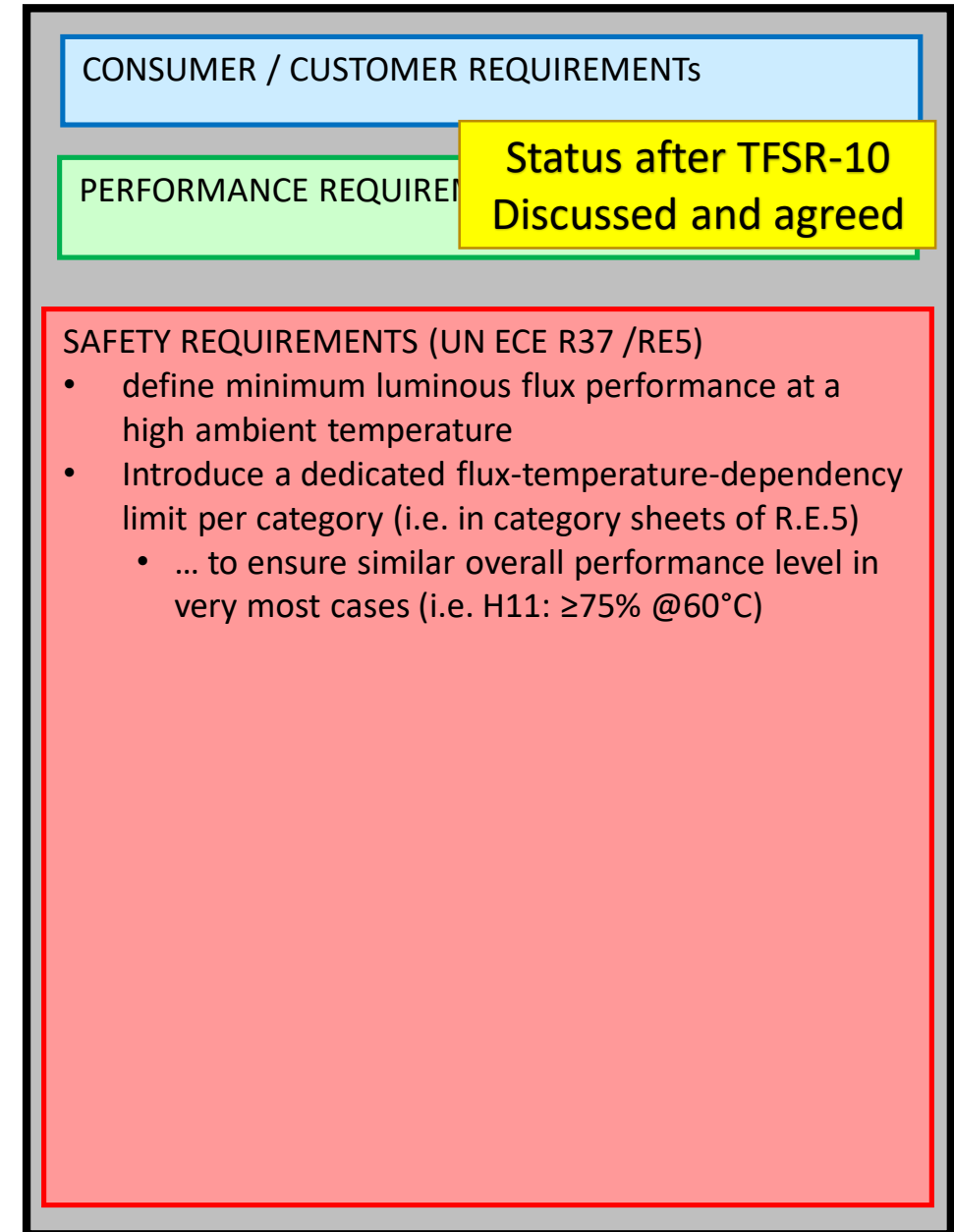
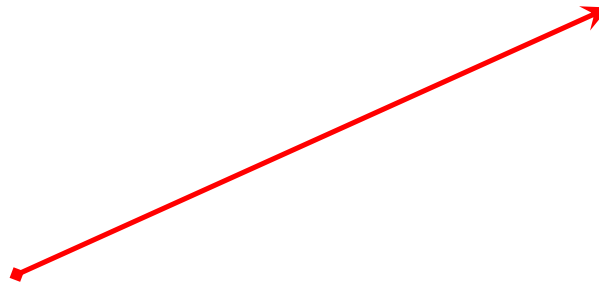



Status after TFSR-10  
Discussed and agreed

# INFO #2: Thermal situation of headlamps

- Application conditions with respect to ambient temperature are subject to statistics
- Typical OEM temperature spectrum “Installation in engine compartment, but not on the engine” →
- Headlamps have one side in the engine compartment, but the other side in the car environment (“*outside air*”)
- Low- and high-beam functions are safety-critical when driving at night, e.g. no sun-load (“ $T_{amb} \sim 15^{\circ}C$ ”)

Temperature (°C)	Distribution (%)
-40°C	6%
23°C	20%
65°C	65%
115°C	8%
120°C	1%

# INFO #2: Thermal situation of headlamps

Translation of temperature spectrum to light source test

Status after TFSR-10  
Discussed and agreed

➤ Assumption: 1/3 of housing is exposed to the “outside air”  $T_{out}$  and 2/3 to the engine compartment  $T_{sp}$  (i.e. impact of the engine side weighted by factor 2)

$$T_{test} \approx \frac{2}{3} \cdot T_{sp} + \frac{1}{3} \cdot T_{out}$$

TFSR-10: Could be simplified to:  
60°C → 75% flux

$T_{sp}$	Distribution	$T_{test}$	Proposed testing	Proposed criteria (e.g. H11)
-40°C	6%			
23°C	20%	~20°C *	Regular test (@23°C) after 30min	1350 lm ± 10%
65°C	65%	~48°C *	Additional test @50°C after 30min	≥80% of value @23°C
115°C	8%	~82°C *	Additional test @80°C after 30min	≥60% of value @23°C
120°C	1%	~85°C *		

\* Based on  $T_{out}=15°C$

intended H11 LEDr proposal

# Real World Comparison

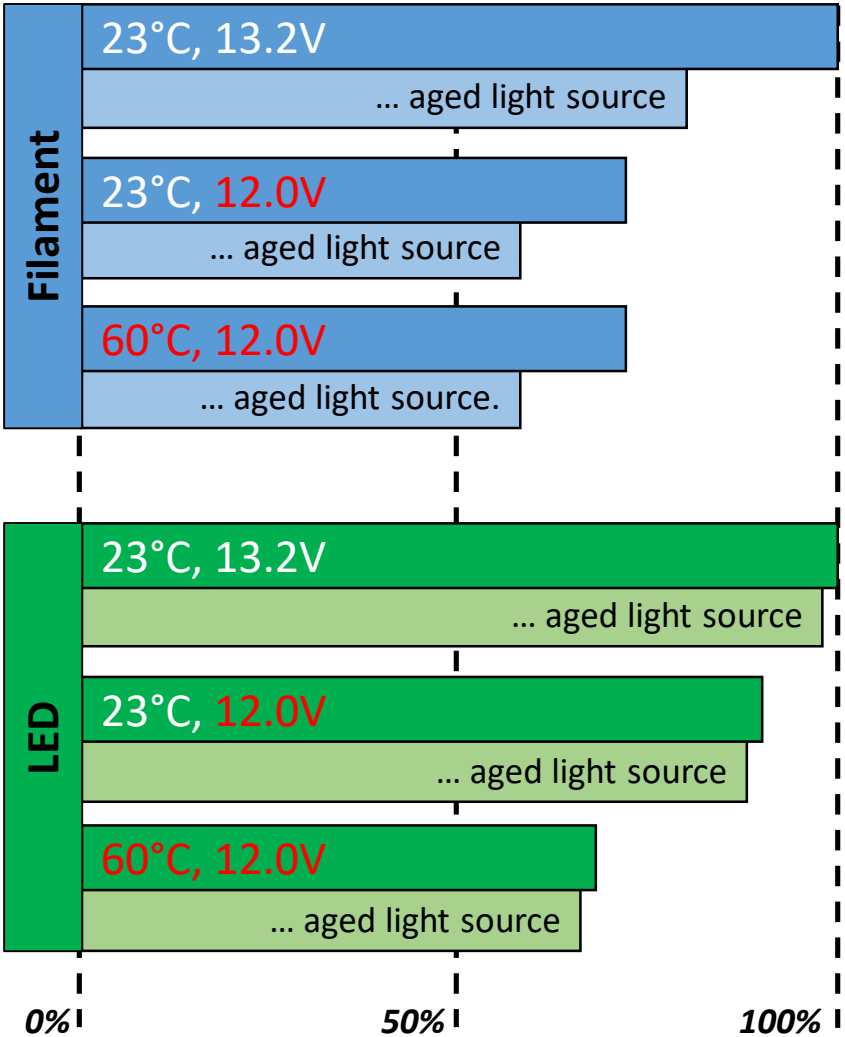

### Filament Technology

- Dependencies are inherent to filament technology
- No additional specifications for R37 filament light sources

### LED Technology

- Dependencies are inherent to LED technology
- Additional specifications for R128 LED light sources can limit the effects (internal electronic is anyhow given)

- Length of bars are on same scale
- Production tolerances (±10%) are same for all, not shown here

Luminous Flux

# Thermal #3A

## - de-fogging

### Question:

Could the de-fogging behaviour of a luminaire be different when an LEDr is used?

### Answer:

Yes, the de-fogging behaviour may be different (can become better or worse). It could change due to the different power consumption and energy balance of the LEDr; the consumer is informed about this.

Status after TFSR-09:  
Discussed without final conclusion

### Discussion during TFSR-09:

- „De-fogging“ is referring to avoiding or removing humidity accumulation inside the luminaire
- Temperature cycles with higher „Delta-T“ lead to higher „humidity pumping-effect“ and vice-versa
- There is no test method / requirement defined in UNECE today.
- No test method known in ISO or IEC
- Reference was made to FMVSS 108 and SAE test requirements

CONSUMER / CUSTOMER REQUIREMENTS

PERFORMANCE REQUIREMENTS (IEC 60810)

SAFETY REQUIREMENTS (UN ECE R37 /RE5)

- require specific user information to be included on de-fogging, where the experience from tests is taken into account

# De-Fogging

Status after TFSR-10  
Discussed and agreed

Comparison tests are planned based on SAE J575

Test 1: headlamp A\* with halogen light source

Test 2: headlamp A\* with LEDr

## SAE Test

### 4.11 Humidity Test

This test determines the ability of the lamp to resist the accumulation of moisture within the lamp that could cause either physical defects to the lamp materials that might affect lamp beam performance or that could persist to affect the photometric performance of the lamp.

[...]

## Requirement

### 5.11 Humidity

There shall be no visual evidence of moisture or condensation on active portions of reflectors and lens(es) on the interior of the device.

\* target: a typical headlamp representative for European market

# Thermal #3B

## - de-icing

### Question:

Could the de-icing behaviour of a luminaire be different when an LEDr is used?

### Answer:

Yes, the de-icing / de-fogging behaviour may be different (can become better or worse). It could change due to the different power consumption and energy balance of the LEDr; the consumer is informed about this.

Status after TFSR-09:  
Discussed without final  
conclusion

### Discussion during TFSR-09:

- Term „de-icing“ not clearly defined; Is it removal of „frozen fog“ in the morning? Or is it removal of snow / ice during driving? Or ...
- No test method defined in UNECE or IEC or ISO
- No test method defined in FMVSS or SAE
- Consequently no test conditions defined (ambient temperature, amount of „ice“, de-icing-time, criteria for being “ice-free”)
- Does this refer to all functions or only low beam?
- Noted that the driver is always responsible to keep vehicle and lighting functions in „clean“ state

CONSUMER / CUSTOMER REQUIREMENTS

PERFORMANCE REQUIREMENTS (IEC 60810)

SAFETY REQUIREMENTS (UN ECE R37 /RE5)

- require specific user information to be included on de-icing

## Thermal #4

### - cap-temperature

#### Question:

Could the lamp cap get hotter with an LEDr compared with a filament lamp and could this lead to damage of the material of the luminaire?

#### Answer:

No, a maximum power or temperature limit for the LEDr avoids this situation. So even though LEDr has less power consumption than the filament lamp, cap temperature is considered relevant.

Status after TFSR-09:  
Discussed and agreed

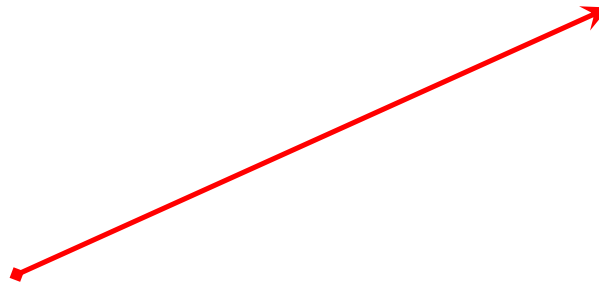

CONSUMER / CUSTOMER REQUIREMENTS

PERFORMANCE REQUIREMENTS (IEC 60810)

SAFETY REQUIREMENTS (UN ECE R37 /RE5)

- either a maximum power limit in the order of 30% of filament case shall be specified for the LEDr or the maximum cap temperature shall be specified for each cap-holder system.

# Cap temperature: *technical background*

- Energy balance different between filament and LED technology
- Avoid thermal overload of holder made for filament light source
- Use typical filament cap temperature as safe reference

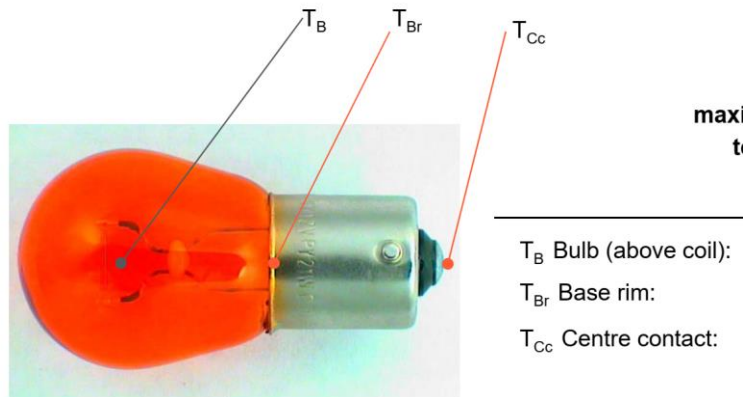

Maximum at  $T_{Br}$ : 90 °C @23°C ambient, 13.5V, flashing

## Measurement point:

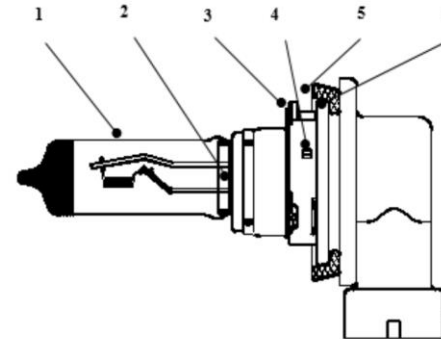

MP1: bulb above the filament  
MP2: pinch at the flap  
MP3: reference lug  
MP4: reference diameter  
MP5: sealing ring above  
MP6: cap

Maximum for MP4:  
150 °C @23°C ambient, 13.2V



Additional slides

# High ambient temperature (*technical background*)

→ Thermal situation of rear lamps

- Application conditions with respect to ambient temperature are subject to statistics
- Typical OEM temperature spectrum for rear lamps  
“Interior exposed to sun radiation”

Temperature (°C)	Distribution (%)
-40°C	6%
23°C	20%
(65°C)* → 50°C	65%
(85°C)* → 100°C	8%
(120°C)* → 105°C	1%

- Spectrum requires 15°C less compared to “engine compartment\*” (headlamp)
- Signaling functions are safety-critical at day and night, e.g. including sun-load
- *Proposal: require >75% at 50°C for categories like PR21W, RY10W*

# High ambient temperature (*technical background*)

→ Thermal situation of integrated Front Direction Indicator

- Application conditions with respect to ambient temperature are subject to statistics
  - Typical OEM temperature spectrum for headlamps “Installation in engine compartment, but not on the engine” applies.
  - Values of “engine compartment” spectrum +20°C compared to low-beam due to “Halogen heating” (night) respectively sun-load (day)
  - Signaling functions are safety-critical at day and night, e.g. including sun-load
- Proposal: require >75% at 80°C for categories like PY21W