

## **Title: Non-Exhaust Brake Emissions — Laboratory testing — Part 1: Inertia Dynamometer Protocol to Measure and Characterise Brake Emissions Using the WLTP-Brake Cycle**

This informal document is submitted by the Informal Working Group (IWG) on Particle Measurement Programme to inform and update the GRPE of the work of the IWG PMP Task Force 1 (TF1) on the development of the novel WLTP-Brake Cycle and its application on the measurement and characterization of brake emissions at brake dynamometer level.

The informal document describes the first part of the PMP Brake Protocol for measuring brake particle emissions and addresses items related to the novel WLTP-Brake Cycle and the inertia dynamometer test itself. The PMP Brake protocol will include three sections aiming to provide a comprehensive protocol for testing facilities:

- Part 1: Inertia Dynamometer Protocol to Measure and Characterise Brake Emissions Using the WLTP-Brake Cycle;
- Part 2: Minimum Requirements and Guidelines for Sampling and Measurement of Brake Emissions for Particle Number and Particle Mass;
- Part 3: Reporting Test Results from Brake Emissions Testing.

This document is submitted mainly with an informative purpose. It is subject to change without notice and may not be referred to as an official report. The contents of the present document will be finalized and included to the official report, hereafter mentioned as PMP Brake Protocol, that will be submitted after the production of the three different sections as listed above.

Health effect studies are under the responsibility of the WHO (World Health Organisation) and outside the scope of the PMP group. Therefore, the proposed methodology is not related to health topics.

Recipients of this draft are invited to submit, with their comments, notification of any relevant patent rights of which they are aware and to provide supporting documentation. To the authors knowledge, none of the work and developments before this publication makes use or reference to any patent. No inventor has come forward, claiming patent infringement.

Any trade name used in this document is information given for the convenience of users and does not constitute an endorsement.

The PMP IWG TF1 on non-exhaust emissions comprises the following participants (listed in alphabetical order): AGUDELO Carlos (*Link Engineering*), ANSALONI Simone (*ITT Friction Technologies*), GRAMSTAT Sebastian (*Audi AG*), GRIGORATOS Theodoros (*European Commission, Joint Research Centre*), GROCHOWICZ Jarek (*Ford Werke GmbH*), MATHISSEN Marcel (*Ford Werke GmbH*), PAULUS Andreas (*TMD Friction GmbH*), PERRICONE Guido (*Brembo S.p.A.*), ROBERE Matt (*General Motors*), SIN Agusti (*ITT Friction Technologies*), VEDULA Ravi (*Link Engineering*).

Comments on the document were provided by: COLIER Sonya (*California Air Resources Board*), HAGINO Hiroyuki (*Japan Automobile Research Institute*) and MARTINI Giorgio (*European Commission, Joint Research Centre*).

## Table of Contents

	Foreword .....	iii
	Introduction .....	v
1.	Purpose .....	1
2.	Scope .....	1
3.	Normative References .....	1
4.	Terms and Definitions .....	2
5.	Symbols, abbreviations, and units .....	20
6.	General inertia dynamometer system requirements .....	21
6.1	Minimum requirements for time-resolved data collection .....	21
6.1.1	Fast channels for brake control and output.....	21
6.1.2	Slow channels for brake and cooling air control and output .....	21
6.2	Brake temperature measurements.....	22
6.3	Wear measurements.....	22
6.3.1	Measurement capabilities .....	23
6.3.2	Measurement positions.....	23
6.3.3	Wear and mass measurement procedure .....	23
6.4	Cooling air conditioning.....	23
6.4.1	Temperature control .....	23
6.4.2	Airflow relative humidity control.....	23
6.5	Control of speed traces during WLTP-Brake Cycle.....	23
6.5.1	Speed violations .....	24
6.5.2	Speed error as RMSSE during WLTP-Brake Cycle or trip #10.....	24
6.6	Vehicle test mass .....	25
6.7	Test inertia.....	25
6.8	Correction for parasitic vehicle losses.....	25
6.8.1	Torque correction with the average vehicle parasitic losses .....	25
6.8.2	Inertia correction with default compensation for parasitic vehicle losses .....	25
6.9	Test setup and brake fixture .....	25
7.	Adjustment of the cooling airstream speed .....	26
7.1	Overview .....	26
7.2	Computation of brake temperatures and acceptance limits .....	26
7.3	Metrics for vehicles with a conventional internal combustion engine .....	27
7.4	Metrics for hybrid or electric vehicles with regenerative braking.....	28
7.5	Brake dynamometer testing to adjust the airstream speed.....	28
7.5.1	Individual brake configurations.....	28
8.	Test sequence .....	29
8.1	Overview and cycle metrics .....	29
8.2	General considerations related to the execution of the standard brake emissions test .....	29
8.3	Detailed metrics for the entire WLTP-Brake Cycle and each trip.....	30
8.4	Test sequence for all brake deceleration events .....	30
8.5	Time-resolved trips and 1 Hz speed profiles .....	34
9.	Test reports .....	34
9.1	EEC files.....	34
9.2	EED files .....	35
	Bibliography .....	38

## Foreword

There is a sharp increase in international interest to characterise non-exhaust traffic-related particle emissions. Until recently, exhaust dominated road transport emissions, and all regulatory efforts were aiming at their reduction. As exhaust emissions reduced, the relative contribution of non-exhaust emissions to overall ambient PM concentrations increased. Furthermore, there are concerns relative to possible adverse health effects of non-exhaust wear particles, and particularly of brake wear particles, due to their small size and their high metal content (Grigoratos and Martini, 2014).

Under the auspices of the UNECE/GRPE, the Particle Measurement Programme Informal Working Group (PMP IWG) has been tasked to investigate the topic of non-exhaust traffic-related particle emissions. The PMP group identified brakes and tyres as the most relevant sources of transport non-exhaust particle emissions in the environment and decided to focus its investigation on these sources (Informal document GRPE-69-23). With regards to brake emissions, the primary task of the PMP IWG has been to develop a new test cycle to represent real-world passenger vehicles' activity. The two other main functions include the development of guidelines and best practices for sampling and measuring brake wear particles and establishing the minimum requirements to report test results.

The Terms of Reference (ToR GRPE-79-14-Rev.1) and rules of procedure for the PMP IWG, including reference to brake particle emissions, were published in June 2016 and updated in June 2019. According to the revised ToR, the PMP IWG needs to work towards the ***“Development of a suggested common test procedure for sampling and assessing brake wear particles, both in terms of mass and number”***. The need for the development of a commonly accepted test procedure relates to the lack of a standardised approach for investigating brake particle emissions (Informal document GRPE-69-23). This absence hinders the ability to understand the behaviour of different brake systems, compare results, and develop strategies to decrease brake emissions when needed. The present Part 1 of the PMP Brake Protocol aims at providing the means for reducing inconsistent results due to different testing procedures, sampling methodologies, and measurement techniques. The objective of the PMP Brake Protocol is to guide future brake wear studies and increase the comparability of the results worldwide.

The PMP IWG decided to initially focus on characterising particles emitted by foundation brakes from light-duty vehicles. The selected driving cycle is the newly developed WLTP-Brake cycle. The cycle development relied on the WLTP database which includes data of more than 750,000 km of vehicle activity from several regions around the world (Mathissen et al., 2018a). The WLTP-Brake Cycle was validated using proving ground testing as well as extensive laboratory testing at several facilities around the world. To assess how feasible, repeatable, and reproducible the cycle is, the PMP IWG performed interlaboratory testing on eight inertia dynamometers (Grochowicz et al., 2019). Lastly, the validation for the airstream speed adjustment method involved a seven-vehicle program on a single dynamometer with adjustable airstream speed.

The PMP IWG methodology needs to simulate real-world driving conditions to the maximum extent possible and create harmonised measurement systems for scientific as well as for Research and Development (R&D) purposes. There are different possibilities with regards to the selection of the most appropriate methodology for brake wear particles sampling and measurement. The PMP IWG extensively discussed the different possibilities and concluded that a carefully designed brake dyno approach fulfils the requirements for a standardized method for measuring brake wear particle emissions. The laboratory setup needs to enable repeatable and reproducible measurements for a set of core (minimum) parameters. With the proper preparation, the installation will allow the end-user to decide additional values worth measuring, within the capabilities of the system. The methodology chosen by the PMP IWG for rigorous sampling and characterisation of brake wear particulate is ***a fully-enclosed brake inertia dynamometer***. This method allows the sampling of Particulate Matter (PM) from brake wear without interferences from other sources and minimises particle losses over the entire sampling and measurement line. Finally, brake inertia dynamometers offer a flexible platform to test different friction couples, under various driving conditions and vehicle loads. Other test and measurement systems, including tribometers and full vehicles measurements, are not part of this Part 1 of the PMP Brake Protocol. Nevertheless, those methods apply to basic research or special projects.

Challenges for standardising the brake dynamometer methodology include:

- a. Proper design of the brake enclosure to minimise particle losses and residence times;
- b. Suitable design of the transport duct and selection of the sampling points to minimise particle losses and ensure representative size distribution(s);
- c. Proper design of the sampling train and sampling nozzles;
- d. Application of the correct airstream speed to replicate real-world temperature regimes and the location of the corresponding sensors (flow or speed, temperature, and relative humidity);
- e. Air filtering system and background levels for particulate matter;
- f. Careful selection and application of the most appropriate measurement techniques and instrument settings;

This part of the PMP Brake Protocol also supports laboratory programs related to brake emissions pursued by other entities or environmental agencies around the world. Among them, the work refers to modelling, characterisation, and measurements from the California Air Resources Board (CARB), the California Department of Transportation (Caltrans), and the Japanese Automotive Research Institute (JARI). Even though these entities may use different parameters, the overall approach, principles, and guidelines on this document apply to their laboratory testing using brake inertia dynamometers.

## Introduction

The collective work performed by several PMP IWG members (Agudelo et al., 2019), coupled with extensive vehicle testing (Collier et al., 2019), has provided sufficient knowledge to standardise a laboratory test cycle. It is easier to repeat, reproduce, and compare test results when using a brake inertia dynamometer. Also, brake inertia dynamometers are standard test systems readily available in many facilities around the world. Laboratory testing ensures a harmonised tool to characterise, and benchmark brake emissions independent of the specific air and particle dynamics related to the vehicle under testing, environmental dilution, and other aerosol interactions.

This part of the PMP Brake Protocol provides all the information necessary to set up, program, and execute the Worldwide Harmonised Light Vehicle-based test procedure (WLTP) derived for braking systems (Mathissen et al., 2018a). From now on the cycle will be referred to as WLTP-Brake Cycle. The main elements of Part 1 of this protocol include:

- References, definitions, and terminology which applies to the WLTP-Brake Cycle as well as to the methodology for sampling and measuring brake wear particle emissions. This section is not finalized and will be reviewed with the final PMP Brake Protocol submission;
- General requirements and capabilities of the inertia dynamometer along with the main test conditions;
- A detailed description of the WLTP-Brake Cycle;
- Minimum requirements to report results from the dynamometer test (excluding actual emissions measurements and metrics). This section is not finalized and will be reviewed with the final PMP Brake Protocol submission.

Brake emissions measurement require a “system’s approach” to testing. Some of the aspects related to a system’s approach include brake cycle control and execution; test setup, inertia, and compensation of parasitic losses; cooling air system, environmental controls (temperature and humidity) and enclosure; constant volume sampling and sampling train design and operation; emissions measurement instruments, dilution, and actual test execution; test engineering processes, data collection, and generation of test reports; filter media handling; weighing equipment and methods; and, chain of custody for test parts and filter media. The Part 1 of the PMP Brake Protocol addresses most of the items related to the inertia dynamometer test itself. The PMP Brake Protocol will comprise three sections aiming to provide a comprehensive guideline for testing facilities:

- Part 1: Inertia Dynamometer Protocol to Measure and Characterise Brake Emissions Using the WLTP-Brake Cycle;
- Part 2: Minimum Requirements and Guidelines for Sampling and Measurement of Brake Emissions for Particle Number and Particle Mass;
- Part 3: Reporting Test Results from Brake Emissions Testing.



# **Non-Exhaust Brake Emissions — Laboratory testing — Part 1: Inertia Dynamometer Protocol to Measure and Characterise Brake Emissions Using the WLTP-Brake Cycle**

## **1 Purpose**

This document defines the test cycle, minimum system requirements, test conditions, and parts preparation to execute the WLTP-Brake Cycle using brake inertia dynamometers. This part of the PMP Brake Protocol also provides general principles and guidelines to design and set up test systems to measure brake emissions. These guidelines are subject to revision following an extensive experimental campaign scheduled within the PMP IWG. The final version of the guidelines will be included in the PMP Brake Protocol.

## **2 Scope**

The current Part 1 of the PMP Brake Protocol applies to the laboratory measurement of brake emissions using single-ended brake inertia dynamometers. In addition to the dynamometer capabilities, the measurement system includes an integral constant volume sampling system, and instruments to measure (or sample) particle mass and particle number. This document applies to category 1-1 vehicles (category 1 vehicle comprising not more than eight seating positions in addition to the driver's seating position), and category 2 vehicles with a fully laden mass below 3.5 tons (ECE -1998 Agreement- TRANS/WP.29/1045). These vehicle classes correspond approximately to categories M1 and N1 (UNECE Reg. 3), or vehicles with a Gross Vehicle Weight Rating below 4540 kg (FMVSS 105 and 135).

NOTE 1: The current release of this part of the PMP Brake Protocol does not address yet specific aspects related to regenerative braking systems. Some crucial elements include driving cycles, methodologies to replicate the brake blending (including Hardware-in-the-Loop), and target brake temperatures.

NOTE 2: The Part 1 of the PMP Brake Protocol can apply to specific projects when the test requestor and the test facility agree on a) the methodology to replicate (simulate) regenerative braking, and b) the target brake temperatures to adjust the cooling airspeed.

## **3 Normative references**

The following documents are referenced in the text (or will be referenced in the final version of the Protocol). Some or all of their content may constitute requirements of this document. For dated references, only the edition cited applies. For undated references, the latest version of the referenced material (including any amendments) applies.

*ECE/TRANS/WP/29/1045 – Special resolution No. 1 — Concerning The Common Definitions of Vehicle Categories, Masses and Dimensions (S.R. 1)*

*UN GTR No. 15 – Worldwide harmonized Light vehicles Test Procedure*

*EN 12341:2014 – Ambient air — Standard gravimetric measurement method for the determination of the PM<sub>10</sub> or PM<sub>2,5</sub> mass concentration of suspended particulate matter*

*EPA Method 1A – Sample And Velocity Traverses for Stationary Sources with Small Stacks or Ducts*

*ISO 611:2003 – Road vehicles — Braking of automotive vehicles and their trailers — Vocabulary*

*ISO 2416:1992 – Passenger cars — Mass distribution*

*ISO 3534-1:2006 – Statistics — Vocabulary and symbols — Part 1: General statistical terms and terms used in probability*

*ISO 8756:1994 – Air quality — Handling of temperature, pressure and humidity data*

*ISO 26824:2013 – Particle characterisation of particulate systems – Vocabulary*

*JCGM 200:2008 (VIM) 2.26 – International vocabulary of metrology – Basic and general concepts and associated terms (VIM)*

*SAE J866:2012-07 – Friction Coefficient Identification and Environmental Marking System for Brake Linings*

*SAE J2263:2008-12 – Road Load Measurement Using Onboard Anemometry and Coastdown Techniques*

*SAE J2789:2018-09 – Inertia Calculation for Single-Ended Inertia-Dynamometer Testing*

*SAE J2951:2014-01 – Drive Quality Evaluation for Chassis Dynamometer Testing*

*SAE J2986:2019-01 – Brake Pads, Lining, Disc, and Drum Wear Measurements*

## **4 Terms and definitions**

For this document, the terms and definitions in TRANS/WP/29/1045 and ISO 26824 Particle characterisation of particulate systems – Vocabulary apply.

Also, ISO and IEC maintain terminological databases for use in standardisation at the following addresses:

- IEC Electropedia: available at <http://www.electropedia.org/>
- ISO Online browsing platform: available at <https://www.iso.org/obp>

### 4.1

#### **driving cycles**

a driving cycle is a series of data points representing the speed of a vehicle versus time. The analysis of the vehicle activity allows the isolation of the cycle into individual trips and each trip into a series of individual and consecutive events:

- brake dwell;
- brake acceleration;
- brake cruising;
- brake deceleration;
- soak time.

Note 1 to entry: The default driving cycle needs to represent the speed of the vehicle at 1 Hz sampling rate.

Note 2 to entry: Other driving cycles different from the WLTP-Brake Cycle are available, yet beyond the scope of the PMP Brake Protocol.

### 4.2

#### **WLTP-Brake Cycle**

##### **WLTP novel cycle**

driving cycle derived from the vehicle activity of Worldwide Light Vehicle Test Procedure with a total duration of 15 826 seconds, in addition to the cooldown periods in-between trips. The cycle comprises 10 trips and 303 brake deceleration events in total. The original WLTP-Brake Cycle includes a soak period with a fixed duration. During the dynamometer test, the first trip starts without warming up the brakes after the cooling air conditions for airspeed, temperature and relative humidity are stable. All subsequent trips (#2 through #10) begin when the brake disc or brake drum reaches an Initial Brake Temperature (IBT) of 40°C. When multiple emission tests are scheduled, the first trip shall start when the brake disc or brake drum reaches an IBT of 40°C.

Note 1 to entry: A complete brake emissions test includes one or several repeats of the WLTP-Brake Cycle performed on the same test samples using the same:

- Brake bedding schedule;
- Friction material and mating brake disc or brake drum;



- Dynamometer setup including brake enclosure, transport tunnel, and sampling train;
- Brake fixture and brake assembly;
- Cooling air settings for temperature, relative humidity and airspeed;
- Instrumentation for measuring particle number, particle mass, and gravimetric sampling.

Note 2 to entry: For specific projects, the brake bedding (burnish) schedule can deviate from the default brake schedule indicated herewith. In such cases, the lab shall provide detailed documentation of the actual schedule on the test report.

Note 3 to entry: For specific projects with additional test sections in addition to brake bedding and WLTP-Brake-cycles, may use test inertia or test conditions different from the ones used during the WLTP-Brake Cycle. In such cases, document in detail the test conditions on the test report.

#### 4.3

##### **brake bedding**

###### burnish

a sequence of braking applications aiming to generate a stable transfer layer, brake effectiveness and level of brake emissions, before conducting the actual cycle to characterise the service brake for emissions.

#### 4.4

##### **brake inertia dynamometer**

a technical system that imposes, controls and records the mechanical work (and associated measurands) on a brake assembly while following an automated test sequence. The dynamometer integrates and controls in real-time:

- Electric motor/drive system;
- Mechanical or simulated inertia;
- Cooling air handling and conditioning system;
- Subsystem (servo controller or equivalent) to impose and control the output of a brake actuator;
- The cluster of sensors and measurement systems;
- Data collection system;
- Software to control the test sequence, record data, and provide the user interface.

Note 1 to entry: Even though there are multiple configurations, the current PMP Brake Protocol uses by default a single-ended brake inertia dynamometer for measuring brake emissions.

Note 2 to entry: Within the scope of this Part of the PMP Brake Protocol, the brake inertia dynamometer must include at least a brake enclosure, transport ducts, filter boxes, instrumentation, and devices suited for brake emissions measurements.

#### 4.5

##### **brake dwell event**

###### brake dwell

denotes a measurable and predictable pause at zero speed during or in-between trips.

#### 4.6

##### **brake acceleration event**

###### brake acceleration

denotes a measurable period during which the linear speed increases at a known rate to a predetermined level during the cycle.

#### 4.7

##### **brake cruising event**

###### brake cruising

denotes a measurable period during which the linear speed (different from zero) remains constant for a

predetermined time during the cycle.

4.8

#### **brake deceleration event**

brake deceleration

denotes a measurable period during which the linear speed decreases at a known rate to a predetermined (final speed or released speed) level during the cycle.

4.9

#### **torque-controlled brake application**

deceleration-controlled brake application

a control algorithm that uses the servo control to modulate in real-time the brake pressure to maintain a constant torque output calculated from the instantaneous deceleration specified in the test cycle.

Note to entry: All brake deceleration events of the WLTP-Brake cycle control torque as a function of a) deceleration rate, b) test inertia, and c) tyre dynamic rolling radius.

4.10

#### **pressure-controlled brake application**

a control algorithm that applies constant brake pressure to the service brake, irrespective of the torque output during a brake deceleration event.

Note to entry: Pressure-controlled applications are not part of the WLTP-Brake Cycle. The definition is included only for completeness.

4.11

#### **constant speed brake drag application**

a control algorithm that controls to a continuous brake torque or continuous brake pressure to the service brake during a braking event, while rotating the brake at a constant speed.

Note 1 to entry: Brake torque level equates to the force required to maintain the speed constant at a given slope and counteract the acceleration due to gravity, multiplied by the tyre dynamic rolling radius.

Note 2 to entry: Brake pressure level can be constant during the entire brake event or replicate a specific profile which changes during the brake event.

Note 3 to entry: Constant speed brake drag applications replicate mountain descents, or ramps in parking structures, where the service brake provides a contact speed during the descent.

Note 4 to entry: Constant speed brake drag applications are not part of the WLTP-Brake Cycle. The definition is included only for completeness.

4.12

#### **vehicle deceleration due to parasitic losses**

$d_{parasitic}$

rate of reduction in linear vehicle speed induced by vehicle parasitic losses; (m/s<sup>2</sup>), (g).

4.13

#### **parasitic vehicle losses**

road load force

the total force encountered by a vehicle because of motion on a level, smooth surface; it includes aerodynamic drag and mechanical drag (front and rear axle frictional and transmissions losses) as a function of vehicle speed.

Note 1 to entry: The aerodynamic drag is a five-term, fourth-order polynomial. After the proper data reduction from the coast down testing, the resulting deceleration force (F) is a three-term (A, B, C) or (f<sub>0</sub>, f<sub>1</sub>, f<sub>2</sub>), second-order equation as a function of velocity (V) in the form of  $F = A + B \cdot V + C \cdot V^2$  ( $F = f_0 + f_1 \cdot V + f_2 \cdot V^2$ ).

Note 2 to entry: The parasitic vehicle losses apply to the entire vehicle, not individual axles.

Note 3 to entry: For the exact method on how to determine, report, and use the road load coefficients  $f_0$ ,  $f_1$ ,  $f_2$ , refer to the UN GTR 15, Annex 4.

Note 4 to entry: To perform the correction:

- a. Convert the road load force into an equivalent vehicle deceleration due to the vehicle parasitic losses;
- b. Subtract the value derived from the previous step from the brake deceleration from the WLTP-Brake Cycle;
- c. Use the resulting deceleration to determine the realtime torque requirement from the service brake.

4.14

### **brake deceleration**

deceleration rate

*d*

rate of reduction in linear vehicle speed induced by the application of the service brake and including the vehicle parasitic losses; (m/s<sup>2</sup>).

Note 1 to entry: For vehicles with hybrid or electric powerplants and powertrains, the deceleration rate also includes the retardation force generated by the regenerative braking.

Note 2 to entry: For the WLTP-Brake Cycle, the dynamometer uses torque-controlled brake applications.

4.15

### **brake stop event**

a generic term used to denote a brake deceleration event which brings the vehicle to complete stop.

4.16

### **brake snub event**

a generic term used to denote a brake deceleration event which reduces the vehicle speed to a non-zero level.

4.17

### **cycle time**

the elapsed time between the onset of one brake application, and the beginning of the next brake application during a brake inertia dynamometer test.

Note 1 to entry: The WLTP-Brake Cycle does not rely on cycle time as a control parameter. However, specific control programs may depend on cycle time to determine the speed control and brake deceleration events.

Note 2 to entry: Historically, cycle time applies to brake deceleration events only. For this document, cycle time is applicable in-between any two different events.

4.18

### **soak time**

time in-between trips when the brake is rotating at low speed (approximately five revolutions per minute) waiting for the IBT to commence the next trip of the cycle. During the soak, the dynamometer cooling air is at the nominal level defined for the entire test.

4.19

### **standard conditions**

pressure equal to 101.325 kPa and temperature corresponding to 293 K.

4.20

### **brake enclosure**

a sealed chamber that prevents untreated (shop or outside) air from entering and contaminating the air flowing around the brake assembly. The brake enclosure shrouds the brake assembly when connected to the brake dynamometer, has an inlet for conditioned and filtered air, and an outlet that connects to the transport duct.

4.21

**layout sector**

part of the test system layout discretised based on its dimensions and geometry (e.g. bend, contraction, straight duct). Part (of the test system layout) whose boundaries are defined by flow disturbances occurring upstream and downstream of the said part.

4.22

**transport duct**

rigid duct connecting the brake enclosure to downstream sampling nozzles which sample brake particles from the air flowing over the brake assembly.

4.23

**sampling nozzle**

a thin-walled stainless steel cylinder, with knife-edge, that mounts on the duct end of a sampling line. The purpose of the sampling nozzle is to extract particle-laden air from the transport duct to the emissions measurement instrument(s).

4.24

**sampling plane**

fixed plane (perpendicular to the duct axis) at the entry of the sampling nozzle(s).

4.25

**sampling line**

flexible or rigid tubing made with (a chemically) inert and conductive (of electrical charges) material to transport the aerosol sampling from the sampling nozzle into the brake emissions measurement instrument(s).

4.26

**positive pressure**

additional pressure generated by the cooling air system used to minimise the intrusion of non-filtered air into the air stream, transporting the aerosol from the brake assembly under test to the measurement instruments.

4.27

**sampling line vacuum**

the negative pressure generated by vacuum pumps in the sampling line to ensure the constant flow of aerosol samples into the brake emissions measurement instrument(s).

4.28

**environmental conditioning system**

climatic control unit

air handling system which provides flow, temperature- and humidity-controlled air into the brake enclosure and transport duct of the brake inertia dynamometer.

4.29

**dynamometer cooling air**

controlled and conditioned air provided to the brake assembly by the environmental conditioning system during the test, through fixed and smooth ducts.

Note 1 to entry: The cooling air needs to have a fixed airstream speed during the entire brake emissions measurement cycle.

Note 2 to entry: The airflow rate may change for different brake sizes for various tests, to provide a brake cooling behaviour to represent a predefined regime.

4.30

**filter box(es)**

mechanical device(s) using High-Efficiency Particulate Air filters, capable of reducing particles of the most

penetrating particle size in the filter material by at least 99.95%, to provide clean air to cool down the brake assembly. The filter box(es) cleans the incoming laboratory air from dust, particles and impurities before reaching the brake enclosure. The filter box also prevents the recirculation of brake emissions emitted by the brake assembly.

4.31

**charcoal filter box(es)**

activated carbon filter box(s)

mechanical device(s) using activated carbon to remove volatiles, hydrocarbons, and other organic compounds from the incoming air.

Note 1 to entry: The charcoal filter box does not replace other devices (like catalytic strippers or thermodenuders) that remove volatile organic compounds emitted by the brake assembly during testing.

Note 2 to entry: The charcoal filter box is an optional part of the system when measuring PN emissions down to 10 nm.

4.32

**airstream speed**

the average speed of the cooling airflow measured in real-time in a length of the straight duct with constant shape and cross-sectional area. The measurement plane shall provide a stable flow away from any obstructions that can cause disturbance or produce a change in the airflow rate.

4.33

**airflow**

the air flowing across the brake enclosure which cools down the brake assembly during the brake inertia dynamometer emissions test.

Note 1 to entry: For non-round duct, use the equivalent hydraulic diameter to convert airstream speed into the airflow value.

Note 2 to entry: Report airflow corrected for temperature and pressure at standards conditions.

4.34

**airflow temperature**

the temperature of the cooling air stream measured in real-time with a calibrated sensor near the entry to the brake enclosure. Additional airflow temperature measurement positions can include positions near the sampling plane or at the exit of the brake enclosure.

4.35

**airflow relative humidity**

amount of water vapour present in the cooling air stream air expressed as a percentage of the amount needed for saturation at the same temperature.

4.36

**system blank**

measurement of PN by means of the same instrumentation as for emissions when the environmental conditioning system and the dynamometer cooling air are running at the levels prescribed herewith, without the brake fixture or the brake assembly mounted.

4.37

**background emissions**

measurement of PN by means of the same instrumentation as for emissions when the environmental conditioning system and the dynamometer cooling air are running under the test conditions, without any brake applications or brake rotation to influence the result.

4.38

**residence (transport) time**

time elapsed from the time the particle is emitted from the brake assembly until it reaches the measurement device inlet (i.e. sampling nozzle).

4.39

**complete vehicle**

a vehicle which does not require further construction stages to fit its design and construction purpose, other than minor finishing operations (such as painting).

4.40

**Unladen Vehicle Mass***UVM*

the nominal mass of a complete vehicle as determined by the following criteria:

- Mass of the vehicle with bodywork and all factory fitted equipment, electrical and auxiliary equipment for normal operation of the vehicle, including liquids, tools, fire extinguisher, standard spare parts, chocks and spare wheel, if fitted.
- The fuel tank is filled to at least 90% of rated capacity, and the other liquid-containing systems (...) to 100% of the capacity specified by the manufacturer.

4.41

**Driving Cycle Vehicle Mass**

vehicle test mass

*DCVM*

unladen vehicle mass plus the weight equivalent of 1.5 occupants. For vehicles, category 1-1, use 75 kg for the weight of the driver and each passenger. The total weight per occupant (75 kg) includes 68 kg as the nominal mass (for driver and each passenger), plus 7 kg provision for luggage.

[SOURCE: TRANS/WP/29/1045 and ISO 2416:1992]

4.42

**tyre dynamic rolling radius**

rolling radius

*RR*

tyre radius that equates to the revolutions per mile, or revolutions per kilometre, published by the tyre manufacturer for the specific tyre size (mm).

[SOURCE: SAE J2789:2018].

4.43

**brake force distribution**

brake work distribution or brake work split or inertia split

the ratio between the braking force of each axle and the total braking force (e.g. 60% front, 40% rear), expressed as a percentage for each axle.

[SOURCE: ISO 611:2003]

default percentage distribution of the total braking force provided by the front and the rear brakes.

[SOURCE: SAE J2789:2018]

4.44

**wheel load***W*

(equivalent) rotating mass as a function of the total vehicle test mass, the axle under test (front or rear), and the brake work distribution among the two axles.

4.45

**brake corner test inertia***I*

wheel load with a radius of gyration equal to the tyre dynamic rolling radius, which imposes the same kinetic energy on the service brake as in the actual vehicle after subtracting the total parasitic vehicle losses. The test inertia is the primary source of kinetic energy during braking and is defined by Equation 1.

$$I = W \cdot RR^2 \quad \text{Equation 1}$$

Note 1 to entry: All rotating components mounted on the main shaft, the flywheel(s), and the main shaft itself of the inertia dynamometer, impose the mechanical inertia for the test. With the appropriate control technology, the main drive on the inertia dynamometer can impose (or absorb) dynamic torque during braking. This feature (inertia simulation) can generate a level of inertia different from the value imposed solely by the flywheels.

Note 2 to entry: Inertia dynamometers equipped with inertia simulation can also correct in realtime the braking torque as a function of total parasitic vehicle losses for a given speed.

[SOURCE: SAE J2789:2018]

4.46

**effective brake inertia***I<sub>eff</sub>*

inertia equivalent to the total energy absorbed by the brake as a function the average-by-distance braking torque, average-by-distance deceleration.

4.47

**inertia compensation**

correction applied to the nominal brake corner test inertia to account for the vehicle deceleration attributable to road load force.

Note 1 to entry: The inertia compensation always results in a brake corner test inertia lower than the nominal value obtained from Equation 1 (4.45).

4.48

**corrected brake inertia***I\**

brake corner test inertia after subtracting the corresponding inertia compensation.

Note 1 to entry: Refer to the actual clause of the document to determine the proper method to apply the corrected brake inertia when needed for a given inertia brake dynamometer.

4.49

**initial speed for a brake deceleration event**

braking speed or initial braking speed

*V<sub>i</sub>*

Service brake speed at the start of a brake deceleration event.

4.50

**final speed for a brake deceleration event**

release speed or final braking speed

*V<sub>f</sub>*

service brake speed at the end of a brake deceleration event.

4.51

**target brake speed***v<sub>Ti</sub>*

target linear speed of the service brake at time *i* during the execution of the test cycle.

4.52

### **dynamometer brake speed**

$v_{Di}$

the equivalent linear speed of the service brake at time *i* during the execution of the test cycle.

4.53

### **speed violation**

any instance when the actual dynamometer speed trace exceeds the speed trace tolerances for the prescribed WLTP-Brake Cycle.

4.54

### **Root Mean Square of Speed Error**

*RMSSE*

the square root of the sum of the squared differences between the actual and the prescribed speed, divided by the number of speed values taken at 1 Hz; (km/h), using Equation 2.

$$RMSSE = 3.6 \cdot \sqrt{\frac{\sum_{i=1}^N (v_{Di} - v_{Ti})^2}{N}} \quad \text{Equation 2}$$

Note 1 to entry: Alternatively, it is common practice to express the speed violations as the ratio (percent) of the RMSSE of the actual test to the maximum RMSSE allowed. A speed violation ratio of 100% would equate to a test performed with a speed trace always reaching the upper or lower tolerance for the duration of the test.

Note 2 to entry: For the entire WLTP-Brake Cycle, the maximum RMSSE equals 3.19 km/h.

[SOURCE: SAE J2951:2014]

4.55

### **residual brake drag**

unintended brake torque resulting from the incidental contact between the friction material and the mating brake disc or brake drum, after the brake actuation is released.

4.56

### **regenerative braking**

method of decelerating the vehicle when the battery management system diverts part of the kinetic energy to charge the battery pack (drive batteries).

Note to entry: Regenerative braking reduces the actual braking forces demand to the service brake and reduce its overall thermal regime during normal driving.

4.57

### **brake assembly**

hardware set with the matching brake disc, brake pads, brake calliper, and associated hardware for a given vehicle and axle application. For drum brake systems, the hardware set comprises the brake drum, brake shoes, brake hardware, and brake mounting plate for a given vehicle and rear axle application.

4.58

### **service brake**

set of components (mechanical, hydraulic or electrical) at the vehicle wheel end primarily responsible for generating vehicle deceleration. By clamping the friction elements (brake pads or brake shoes) against a rotating heat sink (brake disc or brake drum) to transfer the kinetic energy into heat and decelerates the vehicle. Disc brake assemblies clamp the brake pads in the axial direction against a brake disc. Drum brake assemblies clamp the brake shoes in the radial direction against the inside surface of the brake drum.



Note to entry: The service brake can also provide braking torque to overcome the gravitational pull during a mountain descent and provides constant vehicle speed. The WLTP-Brake Cycle does not include such events.

4.59

#### **reference brake**

front or rear brake assemblies from the vehicles used to establish the airstream speed based on proving ground measurements during trip #10. The reference brake is the combination of the (sufficiently identifiable and commercially available) brake disc and friction material, or brake drum and brake shoe. The reference brake helps to a) adjust the cooling airflow speed, b) verify the dynamometer operation before routine testing, c) verify the operation of the brake emissions measurement instruments, and d) perform interlaboratory accuracy studies for repeatability and reproducibility.

4.60

#### **equivalent disc brake**

any disc brake assembly which meets the following criteria compared to the reference brakes:

- Same style (vented or solid, single piece, same friction ring/cheek attached to the disc hat section)
- The same type of material (steel, cast iron, composite)
- The same axle application (front or rear axle)
- For vented brake discs, the outside diameter does not differ by more than 8 mm
- For vented brake discs, the thickness between the friction surfaces does not differ by more than 4 mm
- For solid brake discs, the thickness between the friction surfaces does not differ by more than 2 mm

4.61

#### **equivalent drum brake**

any drum brake assembly which meets the following criteria compared to the reference brakes:

- The same type of material (steel, cast iron, composite)
- The inside diameter does not differ by more than 30 mm
- the width of the friction does not differ by more than 10 mm

4.62

#### **parking brake**

braking device primarily intended to hold a vehicle stationary after having been brought to a standstill, or before driving off a hill in the upward direction of travel.

Note to entry: The WLTP-Brake Cycle does not include brake events involving the parking brake system.

4.63

#### **dynamometer brake test fixture**

dynamometer fixture or test fixture

mechanical device or jig, to mount the brake assembly under testing, connecting the tailstock (non-rotating side) to the inertia dynamometer shaft (rotating side). The tailstock side absorbs the braking torque and associated tangential forces. The rotating shaft transmits the kinetic energy from the test inertia to the brake assembly.

The minimum subsystems the dynamometer brake test fixture includes:

- Mounting components to attach the brake test fixture to the (non-rotating) tailstock;
- Structural components to transfer the braking torque and forces to the tailstock;
- Mounting components to take the brake calliper or the backing plate assembly for drum brakes;
- Rotating parts to mount the brake disc or brake drum onto, ensuring the lateral runout and axial relative positions for the brake calliper or the backing plate assembly for drum brakes;
- Rotating components to connect the shaft of the brake inertia dynamometer to the brake disc or brake

drum.

4.64

**post style fixture**

dynamometer fixture which uses a (machined and with appropriate strength) round and stiff tubing and adaptors, instead of the vehicle knuckle, to mount the brake assembly.

4.65

**knuckle style fixture**

dynamometer fixture where the vehicle-specific knuckle:

- Connects the brake calliper or the drum backing plate assembly to the dynamometer tailstock;
- Provides rotating support for the brake disc or brake drum;
- Ensures the relative mounting positions of the brake components in the radial and axial directions.

4.66

**brake calliper**

a mechanical device that translates driver brake pedal input into clamp force on the brake pads, and thus braking torque in a disc brake system. Brake callipers typically use hydraulic fluid to actuate.

4.67

**brake disc**

brake rotor

rotating, wearable device against which the brake calliper clamps the brake pads in a disc brake system. This device acts as the primary heat absorption and dissipation device as the brake corner translates vehicle kinetic energy into heat.

4.68

**brake pad**

a wearable device that mounts onto the brake calliper consisting of a structural (metal) pressure plate and a friction material element (a.k.a. lining). The brake pads clamp against the brake disc, generating a retarding friction force, and thus braking torque.

4.69

**brake wheel cylinder**

wheel cylinder

a mechanical device that translates the driver input into clamp force on the brake shoe, and thus braking torque in a drum brake system. Brake cylinders typically use hydraulic fluid to actuate.

4.70

**brake drum**

rotating, wearable mechanism against which the brake drum cylinder clamps the brake shoes in a drum brake system. This device acts as the primary heat absorption and dissipation device as the brake corner translates vehicle kinetic energy into heat.

4.71

**brake shoe**

a wearable device consisting of an arced structural metal shoe and a (bonded or riveted) friction material (a.k.a. lining). The brake shoe is clamped against the drum to generate friction, and thus brake torque.

4.72

**friction material edge code**

code to identify the specific friction material supplier, formulation, and environmental marking. In most regions, the edge code appears on the friction material edge or the back of the brake pad or the side of the brake shoe.

4.73

**brake fluid displacement**

transient (volumetric) use of hydraulic fluid by the brake calliper or the brake wheel cylinder during a brake deceleration event; (mm<sup>3</sup>)

Note to entry: This measurement channel is useful to assess the quality of the brake bleed process to remove air from the hydraulic system. Most brake deceleration applications during the WLTP-Brake Cycle requires brake pressures significantly lower than legacy performance testing. Proper brake bleed improves the dynamic response of the brake application system during low-pressure and short brake deceleration events.

4.74

**lateral runout***LRO*

change in the axial distance (from a datum plane) to the braking surface of the brake disc during one complete revolution, at a given radial position; (µm).

Note to entry: Measure the LRO for all angular positions of the brake disc, with the brake disc mounted on the brake fixture and torqued to the vehicle specification, or other predefined torque value.

4.75

**running clearance**

the axial distance between the braking surface of the disc and the brake pad during one complete revolution with the brake released. For drum brakes, the radial distance between the inner diameter of the drum and the brake shoe; (mm).

Note to entry: The running clearance needs to be larger than the LRO at any radial and angular position to avoid sliding contact and hence residual brake drag.

Note 2 to entry: A simple measurement (using filler gages) of the running clearance for a typical disc brake is the sum of the air gaps between each brake pad (or brake shoe) and the brake disc (or inner diameter of the brake drum). Ensure both brake pads (or brake shoes) are on their fully retracted position inside the brake calliper (or fully seated on the brake cylinder) while conducting the measurement for an entire rotation.

4.76

**brake torque***T*

product of the frictional forces resulting from the actuation forces in a brake assembly and the distance between the points of generation of these frictional forces and the axis of rotation.

the torsional moment around the brake axis (opposing the vehicle movement in the travel direction) generated by the application of a clamping force on the brake pads against the brake disc, or on the brake shoes against the brake drum. The brake torque is a function of hydraulic piston area, apparent friction coefficient, and the effective brake radius of the brake corner; (N·m).

4.77

**hydraulic pressure***p*

the pressure generated by the inertia dynamometer to provide the clamping force to the service brake. The hydraulic pressure, combined with the brake apparent friction coefficient and the effective brake radius induce the actual brake torque output; (kPa).

4.78

**threshold pressure***P<sub>threshold</sub>*

minimum hydraulic pressure to overcome the internal friction and seal forces, move the brake calliper's piston or drum wheel cylinder, and onset brake torque output; (kPa).

4.79

**piston diameter**

hydraulic piston diameter

 $d_p$ 

diameter of the hydraulic piston(s) in the calliper, or drum wheel cylinder, and used to calculate the total piston(s) area; (mm).

Note 1 to entry: Always measure the piston diameter on the hydraulic side, where the brake fluid exerts pressure.

Note 2 to entry: Certain callipers have multiple pistons with different diameters. Take this into account when computing the total piston area

4.80

**piston area** $A_p$ 

active area of all hydraulic pistons acting on one side of the brake calliper or drum brake cylinder; (mm<sup>2</sup>).

4.81

**effective brake radius** $r_{eff}$ 

for a disc brake, the distance between the centre of rotation and the centerline of the piston(s). For drum brakes, the half the inner drum diameter; (mm).

4.82

**brake calliper efficiency** $\eta$ 

the ratio of actual output clamp force of a brake calliper or wheel cylinder relative to the theoretical maximum clamp force possible given the applied hydraulic pressure.

4.83

**apparent friction coefficient**

coefficient of friction or brake effectiveness

 $\mu^*$ 

for a disc brake, the apparent friction coefficient value from brake under testing as a function of braking torque, effective brake radius, and the piston area, using Equation 3.

$$\mu^* = \frac{10^5 \cdot T}{2 \cdot (p - p_{Threshold}) \cdot A_p \cdot r_{eff} \cdot \eta} \quad \text{Equation 3}$$

Note 1 to entry: When calculating the average-by-distance apparent friction coefficient for a given brake deceleration event, denote it by the symbol  $\mu$ .

Note 2 to entry: The calculation of the apparent friction coefficient can be for instantaneous values of torque and pressure, or averaged during the duration of the brake deceleration event.

Note 3 to entry: The apparent friction coefficient is a calculated (mathematical) channel and does not use an actual sensor or measuring device.

4.84

**drum effectiveness factor**

internal brake factor or drum brake output

 $C^*$

For a drum brake, the ratio between the tangential force at the drum effective brake radius and the actuation force, using Equation 4 based on the definition provided at ISO 611:611.

$$C^* = \frac{10^5 \cdot T}{(p - p_{Threshold}) \cdot A_p \cdot r_{eff} \cdot \eta} \quad \text{parasitic Equation 4}$$

Note 1 to entry: The calculation of the drum effectiveness factor can be for instantaneous values of torque and pressure or averaged during the duration of the brake deceleration event.

Note 2 to entry: The drum effectiveness factor is a calculated (mathematical) channel and does not use an actual sensor or measuring device.

4.85

### **initial brake temperature**

*IBT*

a measure of the bulk temperature of the brake disc or brake drum at the start of a given brake event (dwell, acceleration, cruising, or deceleration) during the WLTP-Brake Cycle. This temperature can be a test control variable, depending upon the specific point on the test cycle; (°C).

4.86

### **final brake temperature**

*FBT*

a measure of the bulk temperature of the brake disc or brake drum at the end of a given brake event (dwell, acceleration, cruising, or deceleration) during the WLTP-Brake Cycle ; (°C).

4.87

### **average brake temperature**

*A<sub>1</sub>, B<sub>1</sub>*

unfiltered average of the time-resolved brake disc or brake drum temperature at 1 Hz for the entire duration of trip #10; (°C).

Note to entry: The adjustment of the cooling *airstream speed* requires the use of this metric.

4.88

### **average initial brake temperature**

average IBT

*A<sub>2</sub>, B<sub>2</sub>*

average of the unfiltered IBT from the six selected brake deceleration events with high brake power and energy dissipation during trip #10 of the WLTP-Brake Cycle. The six events selected for the average are #46, #101, #102, #103, #104, #106 when trip #10 is considered and #235, #290, #291, #292, #293, #295 when the entire cycle is considered; (°C).

Note to entry: The adjustment of the cooling airstream speed requires the use of this metric.

4.89

### **average final brake temperature**

Average FBT

*A<sub>3</sub>, B<sub>3</sub>*

average of the unfiltered FBT from the six selected brake deceleration events with high brake power and energy dissipation during trip #10 of the WLTP-Brake Cycle. The six events selected for the average are #46, #101, #102, #103, #104, #106 when trip #10 is considered and #235, #290, #291, #292, #293, #295 when the entire cycle is considered; (°C).

Note to entry: The adjustment of the cooling airstream speed requires the use of this metric.

4.90

**maximum brake temperature***A<sub>4</sub>, B<sub>4</sub>*

highest unfiltered temperature measured using the time-resolved temperature at 1 Hz for the entire duration of trip # 10; (°C).

Note to entry: The adjustment of the cooling airstream speed requires the use of this metric.

4.91

**trip average**

averaging method for all the values (of a given channel), taking the entire duration of a trip of the WLTP-Brake Cycle at a sampling frequency of 1 Hz.

4.92

**average by time**

averaging method where the sampling frequency is a unit of time (between data points) through a braking event.

measurand value which yields the same result as the integration between two points in time.

4.93

**average by distance**

averaging method where the sampling frequency is a unit of vehicle distance (between data points) travelled during a braking event.

measurand value which yields the same result as the integration between two distance points.

4.94

**initial value**

the first sampled data point for a given channel after reaching a defined threshold for a given brake event (dwell, acceleration, cruising, or deceleration).

Note to entry: Some examples of threshold values are: the onset of brake pressure, reaching a per cent of the deceleration set-point, and the start of a brake event

4.95

**final value**

the last sampled data point for a given channel after reaching a defined threshold for a given brake event (dwell, acceleration, cruising, or deceleration).

Note to entry: Some examples of threshold values are the release of brake pressure, achieving a given brake speed, or achieving a pre-established elapsed time.

4.96

**minimum value**

for a given event in a brake dynamometer test, the minimum value point for a given channel within the defined analysis window.

4.97

**maximum value**

for a given event in a brake dynamometer test, the maximum value point for a given channel within the defined analysis window.

4.98

**event-based sampling**

collection of data that captures the transient emission behaviour from individual brake events (dwell, acceleration, cruising, or deceleration).

4.99

**cycle-based sampling**

collection of data that captures the emissions characteristics averaged over an entire drive cycle.

4.100

**“fast” sampling rate**

the sampling rate for the data collection system greater than or equal to 250 Hz.

Note 1 to entry: The “fast” sampling rate applies to the dynamometer channels, not for the brake emissions measurement instruments collecting data in the time domain.

Note 2 to entry: For some brake emissions measurement instruments that are multidimensional 1Hz is considered “fast.” For example, size distributions collected at 1Hz are considered “fast”, but there is more information per second than a single value.

4.101

**“slow” sampling rate**

the sampling rate for the data collection system less than or equal to 10 Hz.

Note 1 to entry: The “fast” sampling rate applies to the dynamometer channels, not for the brake emissions measurement instruments collecting data in the time domain.

Note 2 to entry: For some brake emissions measurement instruments that are multidimensional 10 Hz is considered fast. For example, particulate mass distributions collected at 1Hz is considered “fast”, as the amount of mass accrued on a given stage may need a longer time to reach the level of detection value.

4.102

**torque measurement system**

an electromechanical sensor that converts the torsional strain on the brake assembly into the equivalent output voltage. The equivalent torque is a function of the angular deceleration rate and the effective brake inertia.

4.103

**pressure transducer**

an electromechanical device that converts the strain on a membrane subjected to hydraulic pressure into a voltage equivalent to the hydrostatic pressure on the brake fluid.

4.104

**servo control**

servo controller

servo

self-regulating second- or higher-order mechatronic system that modulates braking torque or hydraulic pressure to the intended (set-point) value. The servo control also includes algorithms and mechatronics to provide minimal overshoot, minimal stabilisation time, low oscillation, and small offset relative to the set-point. The minimum configuration of the servo controller needs to include a Proportional-Integral-Derivative (PID) loop.

Note 1 to entry: The servo control also provides the algorithm to control the release of braking torque or pressure at the end of the brake deceleration events.

Note 2 to entry: The servo controller works in real-time with the torque measurement system and the pressure transducer of the brake inertia dynamometer during torque-controlled brake applications

4.105

**particulate matter**

also known as an aerosol, is comprised of solid or liquid particles that remain suspended in a gaseous medium. Particulate matter exists in multiple particle sizes, strongly influencing the (physical and chemical) behaviour and the fate of individual particles over time.

4.106

**particulate mass****PM**

the mass released from the wear due to contact in the friction couple. PM mass concentration is the observed mass per volume of the gaseous medium; ( $\mu\text{g}$ ,  $\text{mg}$ ,  $\mu\text{g}/\text{m}^3$ ,  $\text{mg}/\text{m}^3$ ).

Note 1 to entry: For brake emissions testing, it is common to express PM in  $\mu\text{g}/\text{km}/\text{brake}$  or  $\text{mg}/\text{km}/\text{brake}$ .

Note 2 to entry: In the absence of actual test results from both axles, do not use the inertia split, or other brake or vehicle parameters to extrapolate brake emissions results from one corner to the entire vehicle.

4.107

**PM<sub>2.5</sub>**

particulate matter suspended in the air, which is small enough to pass through a size-selective inlet with a 50% efficiency cut-off at  $2.5\ \mu\text{m}$  aerodynamic diameter ( $\mu\text{m}$ ). PM<sub>2.5</sub> is considered “fine” PM; ( $\mu\text{g}$ ,  $\text{mg}$ ,  $\mu\text{g}/\text{m}^3$ ,  $\text{mg}/\text{m}^3$ ,  $\mu\text{g}/\text{km}/\text{brake}$ ,  $\text{mg}/\text{km}/\text{brake}$ ).

4.108

**PM<sub>10</sub>**

particulate matter suspended in the air, which is small enough to pass through a size-selective inlet with a 50% efficiency cut-off at  $10\ \mu\text{m}$  aerodynamic diameter ( $\mu\text{m}$ ). PM<sub>10</sub> is considered “coarse” PM; ( $\mu\text{g}$ ,  $\text{mg}$ ,  $\mu\text{g}/\text{m}^3$ ,  $\text{mg}/\text{m}^3$ ,  $\mu\text{g}/\text{km}/\text{brake}$ ,  $\text{mg}/\text{km}/\text{brake}$ ).

4.109

**particulate number****PN**

refers to the number of individual particles detected, typically using an optical counter and a c50% efficiency cut-off diameter of 10 nm. PN concentration refers to the number of particles detected per volume of the gaseous medium; ( $\#/ \text{m}^3$ ).

Note 1 to entry: For brake emissions testing, it is common to express PN in other units more applicable to automotive systems, such as ( $\#/ \text{km}/\text{brake}$ ,  $\#/ \text{event}$ ).

Note 2 to entry: In the absence of actual test results from both axles, do not use the inertia split, or other brake or vehicles parameters to extrapolate brake emissions results from one corner to the entire vehicle or from one axle to the other.

4.110

**uncertainty of measurement**

non-negative parameter characterising the dispersion of the quantity values attributed to a measurand, based on the information used (JCGM 200:2008 (VIM) 2.26).

parameter, associated with the result of a measurement that characterises the dispersion of the values that could reasonably be attributed to the measurand. The parameter may be a standard deviation (or a given multiple of it) obtained from results of a series of measurements (VDA 5:2011).

Note 1 to entry: The main measurands related to the operation of the brake inertia dynamometer include torque, speed, coefficient of friction, brake pressure, deceleration, test inertia, brake temperature, cooling air parameters, and wear measurements.

Note 2 to entry: Some components of uncertainty related to brake emissions include, among others: combined uncertainty of measurement for the dynamometer and emissions measurement channels; between-sample (friction couple) variation; residual brake drag; effects of brake bedding and emissions test cycle; intermediate test and measurement systems performance; retention of particles on brake fixture and brake assembly; variation in airspeed and flow on sampling lines; level of isokinetic sampling on individual nozzles; residence times for different particle sizes; interactions in case of multiple probes; losses of PM on transport and storage; effect of humidity on the blank filter mass for PM gravimetric sampling; buoyancy correction method and parameters; balance calibration and uncertainty of measurement; contaminations and background levels for PN and PM; filter’s material, face velocity, and penetration efficiency; interactions with gases and



volatiles; effect of humidity and temperature on particulate matter (particle mass and particle number); mass of sampled and unsampled filter; balance zero drift; and, static charge of the filter and particles.

[SOURCE: EN 12341:2014].

Note 3 to entry: The estimation of the uncertainty of measurement assumes all the factors (components) contributing to measurement variation (linearity, repeatability, reversibility, hysteresis, display error, temperature effect, or calibration error) follow the law of uncorrelated propagation of uncertainty. Components of uncertainty also include those arising from systematic effects associated with corrections and reference standards, contributing to the dispersion.

[SOURCE: VDA 5:2011].

Note 4 to entry: The uncertainty of measurement can be expressed as a function of the full scale of the corresponding measurand, or as a linear (or polynomial regression) function of the value measured by the instrument or sensor.

4.111

### **level of detection**

smallest value detectable (within acceptable error) by a measurement sensor or device above the blank value of the measurand.

4.112

### **repeatability**

test effect

*r*

the closeness of agreement among independent test results obtained with the same method on identical test items in the same laboratory by the same operator (or team of operators) using the same equipment within short intervals of time.

[SOURCE: ISO 3534-1, ISO 5725:1994 – Part 1]

the ability of a measurement sensor, instrument, or entire measurement or test system to generate comparable results. Repeatability conditions require testing the same (design, dimensions, and specifications) component, under the same test conditions and setup, using the same testing process and personnel, and reporting results with the same algorithms and calculations.

Note 1 to entry: Repeatability is commonly expressed as the standard deviation for reproducibility.

Note 2 to entry: In the statistical sense, friction couples are heterogeneous materials. No two friction couples are the same as the individual components vary as a function of raw materials, formulation and composition, manufacturing process, and machining operations.

Note 3 to entry: Some modifications which, if different from test to test, are not actual repeatability conditions include: a) changes to the dynamometer air-cooling conditions, b) brake orientation relative to the incoming air, c) brake test fixture style, d) modifications to the brake enclosure, transport duct and sampling train, e) means to control or measure the brake temperature during the test, and f) sensor position or type to measure the cooling air temperature, humidity, and airspeed/airflow.

4.113

### **Reproducibility**

*R*

the closeness of agreement among independent test results obtained with the same method(s) on a reference component or assembly under repeatability conditions in different laboratories or using various equipment.

Note 1 to entry: Reproducibility is commonly expressed as the standard deviation for reproducibility.

Note 2 to entry: In addition to repeatability, other components of the standard deviation for reproducibility include the sample effect and the laboratory effect.

[SOURCE: ISO 3534-1, ISO 5725:1994 – Part 1]

## 5 Symbols, abbreviations, and units

Symbol	Definition	Unit
$d_p$	Piston or wheel cylinder diameter	mm
$d_{parasitic}$	Parasitic vehicle losses	g
$f_o$	Constant road load coefficient rounded according to paragraph 7. of the UN GTR 15 to one place of decimal	N
$f_1$	First-order road load coefficient rounded according to paragraph 7. of the UN GTR 15 to three places of decimal	N/(km/h)
$f_2$	Second-order road load coefficient rounded according to paragraph 7. of the UN GTR 15 to five places of decimal	N/(km/h) <sup>2</sup>
$p$	Applied pressure	kPa
$p_{threshold}$	Threshold pressure or minimum pressure required to develop braking torque	kPa
$r_{eff}$	Brake effective radius	mm
$v_{Di}$	Dynamometer brake speed	km/h
$v_{Ti}$	Target brake speed	km/h
A	Constant term for the parasitic vehicle losses	N
$A_{1...4}$	Metrics for vehicle or target temperatures	°C
$A_p$	Total piston area	mm <sup>2</sup>
B	Constant of the first-order term for the parasitic vehicle losses	N/(km/h)
$B_{1...4}$	Metrics for dynamometer temperatures	°C
C	Constant of the second-order term for parasitic vehicle losses	N/(km/h) <sup>2</sup>
$C_{1...4}$	Metrics for the temperature difference between vehicle/target and dynamometer	°C
$C^*$	Instantaneous effectiveness value for drum brakes	(unitless)
DCVM	Driving cycle vehicle mass	kg
F	Vehicle parasitic losses torque	N
$I$	Brake corner test inertia	kg·m <sup>2</sup>
$I_{eff}$	Effective brake inertia	kg·m <sup>2</sup>
$I^*$	Corrected brake inertia	kg·m <sup>2</sup>
LRO	Lateral runout	µm
PM	Particle mass	µg, mg, µg/m <sup>3</sup> , mg/m <sup>3</sup> , µg/km/brake; mg/km/brake
PM <sub>2.5</sub>	Particle mass for aerosols with aerodynamic diameter below 2.5 µm	µg, mg, µg/m <sup>3</sup> , mg/m <sup>3</sup> , µg/km/brake, mg/km/brake
PM <sub>10</sub>	Particle mass for aerosols with aerodynamic diameter below 2.5 µm	µg, mg, µg/m <sup>3</sup> , mg/m <sup>3</sup> , µg/km/brake, mg/km/brake
PN	Particle number	#/m <sup>3</sup> , #/km/brake, #/event
RMSSE	Root Mean Square of Speed Error	km/h
RR	Tyre dynamic rolling radius	mm

Symbol	Definition	Unit
$T$	Brake torque	N·m
UVM	Unladen vehicle mass	Kg
$V_i$	Initial speed for a brake deceleration event	km/h
$V_f$	Final speed for a brake deceleration event	km/h
$Y_{1...6}$	Initial brake temperatures to calculate average IBT	°C
$Z_{1...6}$	Final brake temperatures to calculate average FBT	°C
$\mu$	Average by distance friction value for disc brakes	(unitless)
$\eta$	Brake efficiency	%
$RH$	Airflow Relative humidity	%

## 6 General inertia dynamometer system requirements

This clause outlines the set of minimum requirements for any laboratory intending to use inertia dynamometers to measure brake emissions covered on this part of the PMP Brake Protocol. Testing facilities not meeting the minimum requirements outlined in this Part of the PMP Brake Protocol can still conduct brake emissions evaluations. The test facility is also responsible for documenting and notifying the test requestor all deviations from this part of the PMP Brake Protocol, before commencing testing. The final test report needs to document all non-compliances and make them available to any entity reviewing or having access to the measurement results.

NOTE: All test and research facilities (first- and third-party) with active brake emission testing, are encouraged to participate (actively) in interlaboratory accuracy studies for repeatability and reproducibility (Round Robin). Due to the nature and purpose of this part of the PMP Brake Protocol, pay special attention to systems (facilities or individual inertia dynamometers) which generate reduced brake particle emissions on a reference friction couple.

### 6.1 Minimum requirements for time-resolved data collection

#### 6.1.1 Fast channels for brake control and output

Collect continuously and automatically the following channels.

- Brake torque
  - Brake pressure
  - Brake equivalent linear speed
  - Brake fluid displacement
- a. At least 250 Hz during all brake deceleration events
  - b. At least 10 Hz during other brake events (dwell, acceleration, and cruising)

#### 6.1.2 Slow channels for brake and cooling air control and output

Collect continuously and automatically the following channels (including optional) during all brake events (dwell, acceleration, cruising, and deceleration) at a sampling rate of 10 Hz or faster for:

- Brake disc or brake drum temperature
- Brake pads or brake shoe temperature
- Cooling air temperature
- Cooling air relative humidity
- Cooling airstream speed or cooling airflow

## 6.2 Brake temperature measurements

Embed one thermocouple at the centre of the friction path ( $0.5 \pm 0.1$ ) mm deep in the outer face of the brake disc or the inside surface of the brake drum. On vented discs, locate the thermocouple between two fins of the disc plate. Use this thermocouple to control the test temperatures and to initiate individual trips. See Figure 1 for an illustration of the proper installation.

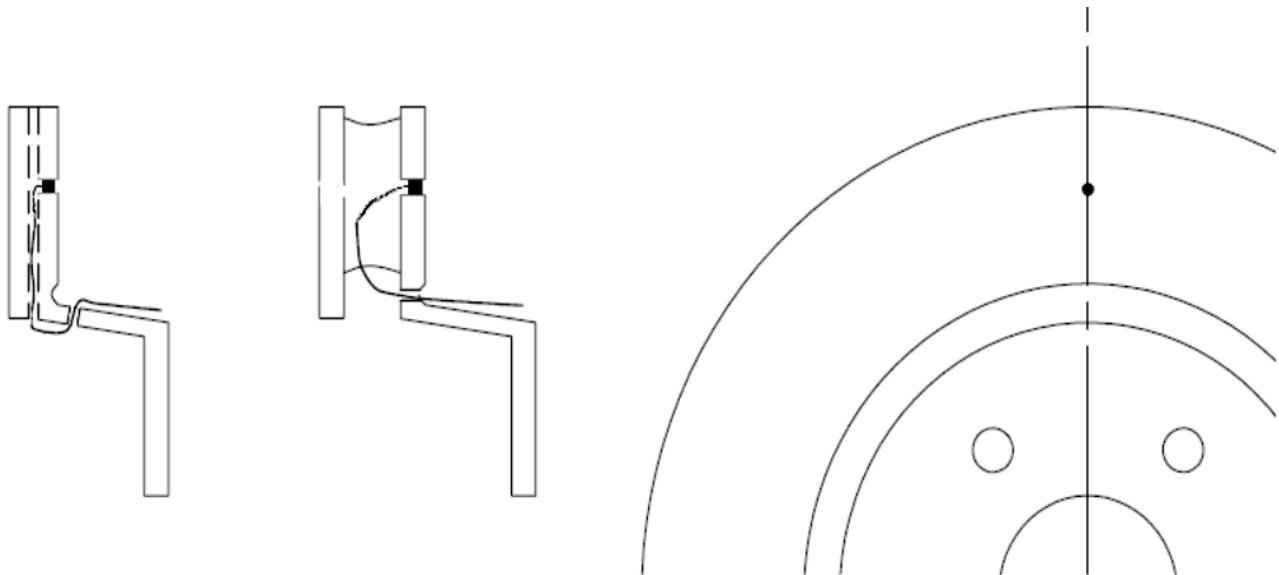

**Figure 1 – Illustration of embedded thermocouple installation on a brake disc**

NOTE 1 — Optional — For brake pads, embed one thermocouple at a depth of 2.0 mm near the centre of the friction surface on each pad. For disc brake pads with grooves, install the thermocouple at least 4.0 mm from the groove edge on the leading side of the pad. For inboard pads on single-piston callipers, install the thermocouple on the leading edge, 3.0 to 4.0 mm from the piston outside diameter near the centre of the friction surface.

NOTE 1A: Pay special attention to the tear, wear, and routing (to allow free calliper movement) of the thermocouple wire for inner pads.

NOTE 2 — Optional — For brake shoes, embed thermocouple at a depth of 1.0 mm near the centre of the friction surface of the most heavily loaded shoe.

NOTE 3 — Optional — For prevent of emission originated from sliding thermocouple sensor, brake shoes, embed irradiation thermometer near the centre of the friction path on the surface of the brake disc or the inside surface of the brake drum.

## 6.3 Wear measurements

The PMP IWG is not mandated to provide recommendations regarding brake wear measurements. Therefore, this particular clause is optional and has not been developed by TF1. The clause is an adaptation from the SAE J2986:2019 Recommended Practice. For detailed definitions, and instructions on how to conduct the wear measurements, consult the corresponding SAE reference.

NOTE 1: According to experience, the thickness height loss of friction materials and the mating brake disc or brake drum can be in the range of  $\mu\text{m}$ . The thickness loss can sometimes be below the detection limit or below the resolution of the measurement instrument. For low-wear cycles, like the WLTP-Brake Cycle, the measuring position is fundamental for the repeatability and producibility of the thickness loss data. Other elements that can influence the accuracy of the measurement technique include anti-noise shims, pad-piston spring, and other parts installed on brake pads.

NOTE 2: As a general practice, and if the aim is to provide further correlation to PM measurements, prefer mass loss measurements over thickness loss measurements only.

### 6.3.1 Measurement capabilities

- For measuring brake discs, brake pads, and brake shoes, use a micrometre or equivalent device with an accuracy of 0.01 mm or better, flat surface(s) on the side(s) contacting the friction material or anti-noise shims, and a ratchet mechanism;
- For measuring the internal brake drum diameter, use a digital vernier calliper or equivalent device with an accuracy of 0.01 mm or better;
- Weighing scale with an accuracy of 0.01 g or better for parts below 10 kg of total weight;
- Measuring instruments, grids, templates, forms, or data entry templates to assign the measurements to a specific test, test section, and component;
- Measuring room with appropriate controls for temperature and humidity.

### 6.3.2 Measurement positions

- For brake pads, measure at eight locations equally spaced and located approximately 5.0 mm from any edge of the friction material (pad contour, chamfers, or slots). Smaller pads (like those on rear brakes for small vehicles), may accommodate as few as four locations;
- For brake shoes, measure at eight positions equally spaced. Locate the measurement position midpoint between the long edge and the nearest edge of the shoe web. Keep at least 10 mm or 20% of the total lining width from the edge of the friction material and chamfers at the ends;
- For brake discs, measure at eight positions, in four groups of two, distributed every 90°. At each clock position, measured at 5.0 mm from the outer diameter and 5.0 mm from the inner diameter of the braking surface. Exclude chamfers or round edges to mark the measurement position;
- For brake drums, measure at six locations, in three groups of two, distributed every 120°. At each clock position, measured at 10 mm from the outer (open) edge and 10 mm from the inner (mounting) edge of the braking surface. Exclude chamfers or round edges to mark the measurement position;

### 6.3.3 Wear and mass measurement procedure

- Rely on technicians and operators proficient and familiar with the measurement process outlined herewith;
- Use only instruments in proper working conditions and with valid calibration certificates;
- Measure the brake pads including the anti-noise shims, pad-shim springs, and other elements when part of the product pad assembly;
- Ensure all parts are at ambient temperature, clean, free from debris, and with thermocouples installed during the initial and final mass measurements;
- Inspect all parts for burs, cracks, voids, or detachments and record accordingly.

## 6.4 Cooling air conditioning

### 6.4.1 Temperature control

- Control the trip average to  $(20\pm 2)^{\circ}\text{C}$ , measured before the cooling air enters the brake enclosure. The same temperature shall apply during the bedding procedure;
- During the adjustment of the cooling airstream speed per clause 7, it is acceptable to maintain a limit of  $(20\pm 5)^{\circ}\text{C}$  for less than 5% of the duration of trip #10.

### 6.4.2 Airflow relative humidity control

- Control the trip average to  $(50\pm 5)\% \text{RH}$ , measured before the cooling air enters the brake enclosure. The same relative humidity shall apply during the bedding procedure;
- During the adjustment of the cooling airstream speed per clause 7, it is acceptable to maintain a limit of  $(50\pm 10)\% \text{RH}$  for less than 10% of the duration of trip #10.

## 6.5 Control of speed traces during WLTP-Brake Cycle

### 6.5.1 Speed violations

This clause is an adaptation from the GTR 15 regulation.

- During the execution of the entire WLTP-Brake Cycle, or trip #10 during the adjustment of the cooling airstream speed, do not exceed 10% of speed violations;
- A speed violation occurs whenever the actual speed of the dynamometer exceeds the speed trace tolerances, compared to the prescribed (nominal) speed;
- Upper-speed tolerance: 2.0 km/h higher than the highest point of the prescribed trace within  $\pm 1.0$  second of the given point in time;
- Lower-speed tolerance: 2.0 km/h slower than the lowest point of the prescribed trace within  $\pm 1.0$  second of the given point in time.

See Figure 2 for a depiction of the upper and lower tolerance limits.

NOTE: The computation of speed violations apply to all cycles and types of events (dwell, acceleration, cruising, and deceleration).

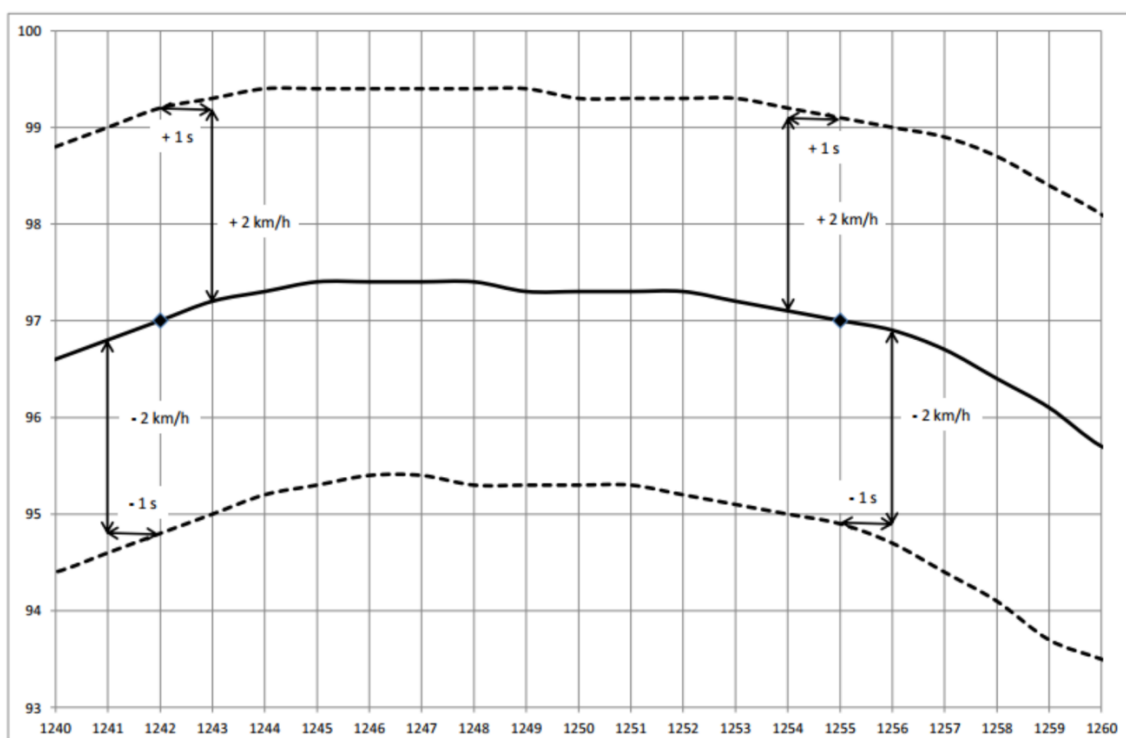

**Figure 2 – Tolerance limits for speed violations during WLTP-Brake Cycle [UN GTR No. 15]**

### 6.5.2 Speed error as RMSSE during WLTP-Brake Cycle or trip #10

This clause is an adaptation of SAE J2951:2014. Use Equation 2 for RMSSE in km/h.

- Do not exceed an RMSSE of 1.6 km/h. This RMSSE is equivalent to a 50% speed error;
- When the RMSSE is between 1.6 km/h and 3.2 km/h, review the results in detail and present the findings to the test requestor;
- When exceeding an RMSSE of 3.2 km/h, deem the test as defective, conduct a root-cause finding activity, and present the findings to the test requestor.

NOTE: The computation of speed error (RMSSE) apply to all cycles and types of events (dwell, acceleration, cruising, and deceleration).

## 6.6 Vehicle test mass

Set the test mass per Equation 5 to equate to the Unladen Vehicle Mass plus 1.5 occupants.

$$DCVM = UVM + 1.5 \cdot 75 \quad \text{Equation 5}$$

NOTE: Other test masses are allowed upon agreement between the test requestor and the testing facility. The test requestor may mandate exceptional test cases at vehicle laden mass, gross vehicle weight rating, or other, depending upon the project.

## 6.7 Test inertia

Set the test inertia to reflect the brake force distribution (inertia split) between the front and rear axles for the vehicle under testing and the tyre dynamic rolling radius. Follow any of the options below, in descending order of preference to determine the test inertia. Document on the test report the actual method used.

- Use the brake force distribution (inertia split) specified by the vehicle manufacturer for the axle under testing, and confirmed by the test requestor;
- Use the brake force distribution (inertia split) per the default method on the SAE J2789 for decelerations below 0.65 g.

## 6.8 Correction for parasitic vehicle losses

To reflect the parasitic losses of the vehicle, apply one of the following correction methods, in descending order of preference. Document on the test report the method used.

### 6.8.1 Torque correction with the average vehicle parasitic losses

- Use the  $f_0$ ,  $f_1$ ,  $f_2$  (A, B, C) parameters, along with the initial speed, the final speed, and the DCVM values to calculate the average deceleration from the vehicle parasitic losses using Equation 6.

$$d_{parasitic} = \frac{f_0 \cdot (V_i - V_f) + f_1 \cdot \frac{(V_i^2 - V_f^2)}{2} + f_2 \cdot \frac{(V_i^2 - V_f^2)}{3}}{DCVM \cdot (V_i - V_f)} \quad \text{Equation 6}$$

- Reduce the average deceleration setpoint for the event by an amount equal to the value from Equation 6 to determine the actual torque demand from the service brake;
- Use the resulting deceleration to calculate the corrected torque as the torque setpoint (demand) for the service brake.

NOTE 1: The control technology and algorithms of the brake inertia dynamometer differ among system manufacturers. Different systems may combine torque control, motor drive control, and inertia simulation to induce the correct dissipation of kinetic energy during braking.

NOTE 2: This torque correction does not modify the deceleration rate in the speed domain, which needs to follow the prescribed speed profile of the WLTP.

NOTE 3: Some control systems allow the dynamometer to correct in real-time, the deceleration demand to the service brake. The correction algorithm utilizes the  $f_0$ ,  $f_1$ ,  $f_2$  (A, B, C) parameters for the test vehicle.

### 6.8.2 Inertia correction with default compensation for parasitic vehicle losses

For brake inertia dynamometers which cannot apply the correction per clause 6.8.1, reduce the test inertia by 13% for the entire test.

## 6.9 Test setup and brake fixture

Perform the following tasks before commencing the airstream speed adjustment or the actual test to measure brake emissions.

- Verify the availability of all the test documentation, test request with project and brake information, special instructions, control program, dynamometer capabilities, and test conditions for the project;
- Update or upload the corresponding control program, test parameters and conditions, project and brake information onto the inertia dynamometer control system;
- If conducting brake emissions testing, ensure all the instruments and filter media are available per the standard operating procedure;
- Install the brake assembly onto the test fixture and the dynamometer tailstock, and connect with the adaptors to the main dynamometer shaft. As a general principle, the brake orientation relative to the incoming airstream needs to favour the transport efficiency, and reduce the residence time of brake particles in the brake enclosure. Detailed description regarding the recommended brake orientation will be provided to the final version of the PMP Brake Protocol;
- Install the brake pads or brake shoes and perform a thorough brake bleed to remove air bubbles from the brake lines;
- Verify LRO, running clearance, and any residual brake drag;
- Perform a visual inspection of the service brake, brake fixture, thermocouple wires, and hydraulic brake lines to ensure proper routing and connections;
- Close the brake enclosure, turn on the environmental conditioning system and verify the operation of the cooling air system;
- Adjust the airstream for the axle and service brake type under test, and verify the background emissions levels are within the acceptable limits. Detailed recommendations regarding the background emissions will be provided to the final version of the PMP Brake Protocol;
- Perform check-stops to verify data collection, test parameters, test inertia, and overall system operation;
- If no issues arise, commence the actual test sequence and follow the standard operating procedures.

## **7 Adjustment of the cooling airstream speed**

### **7.1 Overview**

The cooling air on the brake inertia dynamometer provides stable and predictable conditions during emissions testing (airstream speed, air temperature, and air humidity). Different test systems can embody different combinations and performance related to brake enclosure design and size, brake mounting relative to the incoming air, airflow levels, and duct system layout and specifications. There is a need to test under reproducibility conditions the same brake and friction couple in multiple facilities. This clause of the PMP Brake Protocol establishes the proper methodology to adjust the airstream speed to provide comparable thermal regimes across facilities.

NOTE: The only brake deceleration events accepted to determine the average IBT and average FBT are events #46, #101, #102, #103, #104, and #106 from trip #10 of the WLTP-Brake Cycle. When the entire cycle is considered the corresponding events are #235, #290, #291, #292, #293, and #295.

### **7.2 Computation of brake temperatures and acceptance limits**

To determine the appropriate airstream speed for a given brake (or equivalent disc brake or equivalent drum brake), perform repetitions of trip #10 to obtain the parameters to populate the cells on Table 1 and compare to the limits on Table 2.

- a. Calculate the following parameters from vehicle (proving ground) data or select the corresponding default values from Table 2:
  - Average brake temperature ( $A_1$ )
  - Average IBT ( $A_2$ )
  - Average FBT ( $A_3$ )
  - Maximum brake temperature ( $A_4$ )
- b. Calculate the following parameters from the dynamometer data:



- Average brake temperature ( $B_1$ )
  - Average IBT ( $B_2$ ) from the individual values ( $Y_{1..6}$ )
  - Average FBT ( $B_3$ ) from the individual values ( $Z_{1..6}$ )
  - Maximum brake temperature ( $B_4$ )
- c. Calculate the differences between vehicle/target and dynamometer results for the following parameters:
- Absolute difference ( $C_1$ ) in average brake temperature between  $A_1$  and  $B_1$
  - Absolute difference ( $C_2$ ) in average IBT between  $A_2$  and  $B_2$
  - Absolute difference ( $C_3$ ) in average FBT between  $A_3$  and  $B_3$
  - Absolute difference ( $C_4$ ) in maximum brake temperature between  $A_4$  and  $B_4$
- d. Compare the results from step c. with the acceptance limits from Column D on Table 1 (also included as the last row in Table 2).

**Table 1 – Calculation of brake disc or brake drum temperature metrics and limits during trip #10**

Event [#]	Metric	Column A	Column B	Column C	Column D
		Vehicle/Target [ °C]	Dynamometer [ °C]	Difference [ °C]	Acceptance [ °C]
–	<i>Average brake temperature</i>	$A_1$	$B_1$	$C_1= A_1-B_1 $	$C_1 \leq 10$
46			$Y_1$	n/a	n/a
101			$Y_2$	n/a	n/a
102			$Y_3$	n/a	n/a
103			$Y_4$	n/a	n/a
104			$Y_5$	n/a	n/a
106			$Y_6$	n/a	n/a
–	<i>Average IBT</i>	$A_2$	$B_2=AVG(Y_1:Y_6)$	$C_2= A_2-B_2 $	$C_2 \leq 15$
46			$Z_1$	n/a	n/a
101			$Z_2$	n/a	n/a
102			$Z_3$	n/a	n/a
103			$Z_4$	n/a	n/a
104			$Z_5$	n/a	n/a
106			$Z_6$	n/a	n/a
–	<i>Average FBT</i>	$A_3$	$B_3=AVG(Z_1:Z_6)$	$C_3= A_3-B_3 $	$C_3 \leq 25$
–	<i>Maximum brake temperature</i>	$A_4$	$B_4$	$C_4= A_4-B_4 $	$C_4 \leq 25$

### 7.3 Metrics for vehicles with a conventional internal combustion engine

The preferred method to establish the target thermal regime for a given vehicle application is to rely on measurements taken from trip #10 on the proving ground. In the absence of proving ground data, use the limits from Table 1. Parameters  $A_1$  through  $A_4$  refer to the labels in Table 2.

NOTE: This version of the PMP Brake Protocol does not consider tolerances for brake discs fitted on vehicles with regenerative braking systems.

**Table 2 – Default temperature limits for brake discs and brake drums during trip #10**

Axle	Brake type	Average brake temperature		Average IBT		Average FBT		Maximum brake temperature	
		[°C]		[°C]		[°C]		[°C]	
Front	Disc vented	A <sub>1</sub>	85	A <sub>2</sub>	85	A <sub>3</sub>	135	A <sub>4</sub>	170
Rear	Disc vented		65		65		95		115
Rear	Disc solid		80		85		135		180
Rear	Drum		60		65		120		175
Acceptance		± 10		± 15		± 25		± 25	

#### 7.4 Metrics for hybrid or electric vehicles with regenerative braking

It is not yet specified how the regenerative contribution to braking will be taken into account during the method development. Therefore, this part will be updated at a later stage to include hybrid and electric vehicles.

#### 7.5 Brake dynamometer testing to adjust the airstream speed

##### 7.5.1 Individual brake configurations

Follow these steps to adjust the airstream speed when testing for the first time on a given dynamometer. After completing the process, use of the same airstream speed for subsequent testing under repeatability conditions.

- Follow the guidelines and steps from clause 6.9 before commencing the actual test;
- Adjust the airstream speed to a known value used for similar brakes when testing under reproducibility conditions. In the absence of prior history or a useful reference, use an airstream speed between 20% and 25% of the full scale for dynamometer cooling system;
- When applying new parts (brake disc and brake pads), conduct five WLTP-Brake Cycles as the standard laboratory bedding (burnish) practice. Details regarding the correct application of the bedding procedure will be provided to the final PMP Brake Protocol;

NOTE 1: Alternatively, use pre-bedded (burnished) friction couples or from different bedding (burnish) schedule, approved by the test requestor.

- Conduct one repetition of trip #10 of the WLTP-Brake Cycle with an IBT of 40°C (warm-ups, if necessary, are defined as sequence of stops 1 to 7 of trip 10 with subsequent cooling phase down to 40°C). Alternatively, to expedite the trial runs, starting each test with IBT of 40°C, program a series of tests at different airstream speed levels, and then assess a batch of test results.
- Perform the calculations using clause 7.2 and assess the results and deviations, including the assessments defined on clauses 6.5 and 6.8;
- If the test run (last execution of trip #10) meets all the metrics from Table 2, finish the process, document the findings, and proceed with standard testing ensuring repeatability conditions. Use the airstream speed during standard testing for equivalent brake discs;

NOTE 1: When conducting the first test on an equivalent disc brake on a given inertia dynamometer, verify the brake assembly meets the temperature metrics on clause 7.2 and clause 7.3.

NOTE 2: Prefer an airstream speed which is the same as one already defined for other brakes and tends to keep the brake assembly on the lower range of the temperature tolerance. Take the appropriate steps to ensure the maximum temperature does not reach the upper limit of tolerance. Higher-than-normal brake temperatures may skew the PN measurements during subsequent standard tests.

NOTE 3: Once results from several brakes and vehicle applications are available, assess commonality related to the airstream speed values.

- g. If the test run (last execution of trip #10) does not meet all the metrics from Table 2, use engineering judgement to determine a new airstream speed and repeat the process from step 7.2.b;
- h. In case there is no suitable combination of airstream speeds to meet all the metrics from Table 2, define further changes or adjustments. Consult with technical experts or the test requestor to consider changes to the brake orientation or modifications to the actual test setup (including revising test parameters like test inertia) as deemed appropriate and practical. In case there are no reasons to make further changes to the test and still, all the metrics from Table 2 are not met, select the airflow and setup that is within the acceptable limits for three parameters, always including the maximum brake temperature and average FBT. Ensure to include the compliance to the brake temperature metrics on the final test report.

## 8 Test sequence

### 8.1 Overview and cycle metrics

Different from legacy test procedures, the WLTP-Brake Cycle demands the continuous control of the equivalent linear speed of the brake. The laboratory staff needs to work closely with the engineering staff creating or providing the control program. Before commencing any system upgrades to enable brake emissions measurements, conduct a detailed assessment (with validation tests) of the inertia dynamometer capabilities. The control and drive systems need to follow the speed trace and meet the speed metrics per clause 6.5. Figure 3 depicts the speed trace for all ten (10) trips.

In summary, the WLTP-Brake Cycle includes:

- 15 826 seconds of active speed control;
- 1084 individual events including soaks, dwells, acceleration, cruising, and deceleration events;
- 303 brake deceleration events, separated into ten (10) individual trips;
- 192 km of total distance travelled for one cycle;
- Average braking speed of 42 km/h and a maximum of 132 km/h;
- Average deceleration of 0.9 m/s<sup>2</sup> and a maximum of 2.2 m/s<sup>2</sup>;

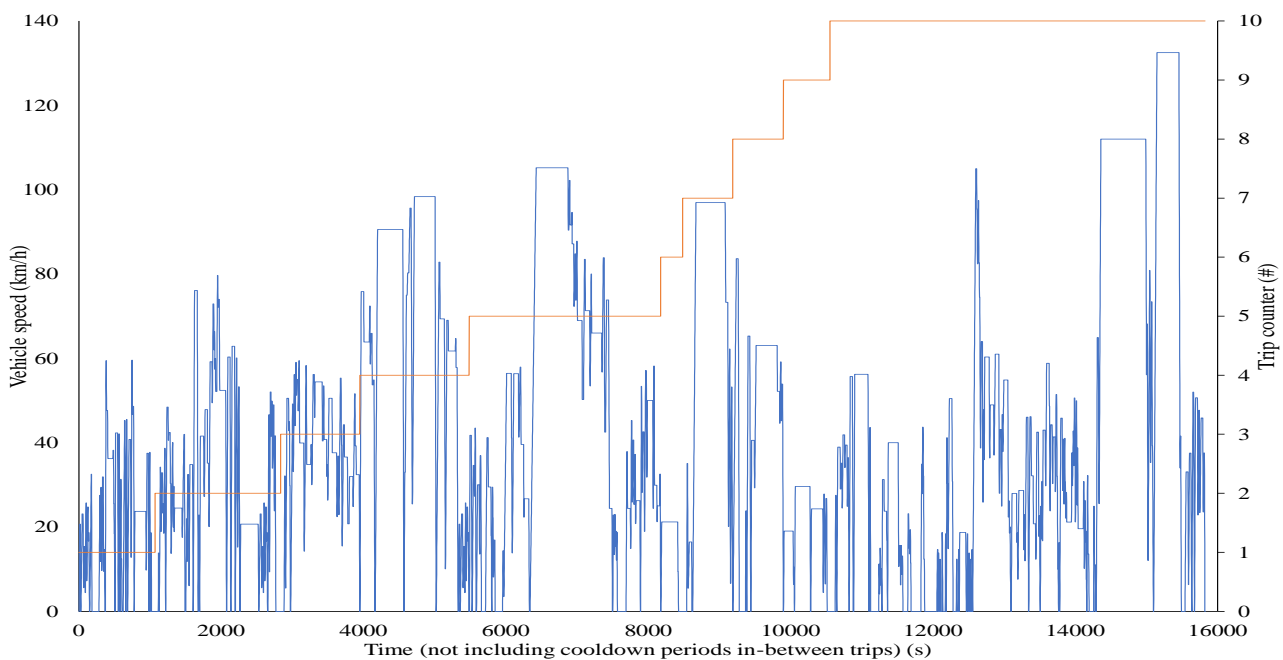

**Figure 3 – Time-resolved vehicle speed for the WLTP-Brake Cycle**

### 8.2 General considerations related to the execution of the standard brake emissions test

- Confirm with the test requestor, and document accordingly, the decisions about optional items and special instructions, before staging the test;

- Each cycle (or repeat) of the WLTP-Brake involves the performance of ten (10) trips in succession;
- For the first repeat of the cycle, commence trip #1 at ambient temperature without conducting any warm-up stops or snubs;
- For all subsequent trips including trip #1 for the additional cycles, wait until the brake reaches an IBT of 40 °C. Notes 1 to 2 below is default unless otherwise instructed by the test requestor. Notes 1 to 3 are subject of discussion within the TF2 and an updated version with more details will be provided to the final PMP Brake Protocol.

NOTE 1: In the event the test is interrupted (or the dynamometer faults) during the bedding procedure, continue the bedding without conducting any warm-up stops or snubs to achieve the IBT of 40°C.

NOTE 2: In the event the test is interrupted (or the dynamometer faults) in-between trips, continue the test without conducting any warm-up stops or snubs to achieve the IBT of 40°C provided that the interruption does not exceed a reasonable amount of time.

NOTE 3: In the event, the test is interrupted during trips #1 through #10 restart the brake emissions tests from the beginning.

- Unless otherwise indicated by the test requestor, conduct the first five (5) WLTP-Brake Cycles as the test-bedding (burnishing) schedule. Always report the actual number of bedding (burnishing) cycles for the test and all the cycles performed after the bedding (burnish). This part is subject of revision following TF2 recommendations. The suitability of alternative bedding methods is currently being evaluated;
- Before the standard testing, review with the test requestor whether or not to conduct mass particle sampling, with detailed planning for instruments using mass collection;
- In case the test faults during the execution of a trip, assess the root-cause, implement contingency or remedial measures, and define the proper trip or cycle to continue the test;
- Always report any inconsistencies concerning the application (use) of this test protocol.

### 8.3 Detailed metrics for the entire WLTP-Brake Cycle and each trip

It is essential to become familiar with the WLTP-Brake Cycle understanding the primary metrics which characterise the entire cycle and each trip. The metrics include the following:

- Time metrics for each type of event;
- Speed metrics for minimum, average, 95<sup>th</sup> percentile, and maximum;
- Brake stop and snubs events as count or per cent of the total number of deceleration events;
- Speed bins for deceleration events as count and per cent;
- Deceleration metrics for minimum, average, 95<sup>th</sup> percentile, and maximum;
- Stop/snubs duration metrics for minimum, average, 95<sup>th</sup> percentile, and maximum;
- Total distance travelled per trip or for the entire cycle;
- Kinetic Energy and brake power metrics per kg of vehicle mass for minimum, average, 95<sup>th</sup> percentile, maximum, density per km travelled, and density per hour of driving.

See Table 3 for a summary of the most critical metrics.

### 8.4 Test sequence for all brake deceleration events

See Table 4 for the sequence of all braking events for all trips. The values in the table describe the markers for the trip number, marker for brake deceleration event number for the entire cycle and the corresponding trip, time stamps with the start time for each event, and the braking parameters corresponding to the event duration, braking and final speed, and total deceleration level (including the vehicle parasitic losses).

**Table 3 – Metrics for the entire WLTP-Brake Cycle and each trip**

Metric	units	All Trips	Trip 1	Trip 2	Trip 3	Trip 4	Trip 5	Trip 6	Trip 7	Trip 8	Trip 9	Trip 10
<b>time</b>												
total/cycle	s	15822	1070	1765	1112	1537	2691	308	705	711	655	5268
% of cycle		100%	6.8%	11.2%	7.0%	9.7%	17.0%	1.9%	4.5%	4.5%	4.1%	33.3%
initial soak	s	238	4	45	48	2	4	2	57	2	2	72
total accel	s	2505	224	355	231	216	430	12	78	112	45	802
total cruise	s	9665	466	1005	708	1150	1691	227	505	442	525	2946
total braking	s	1714	178	242	119	138	253	9	53	59	37	626
total idle	s	1477	149	50	5	27	312	0	11	95	6	822
final soak	s	223	49	68	1	4	1	58	1	1	40	0
<b>type of event</b>												
initial soak	%	1.5%	0.4%	2.5%	4.3%	0.1%	0.1%	0.6%	8.1%	0.3%	0.3%	1.4%
acceleration	%	15.8%	20.9%	20.1%	20.8%	14.1%	16.0%	3.9%	11.1%	15.8%	6.9%	15.2%
cruise/steady drive	%	61.1%	43.6%	56.9%	63.7%	74.8%	62.8%	73.7%	71.6%	62.2%	80.2%	55.9%
deeleration	%	10.8%	16.6%	13.7%	10.7%	9.0%	9.4%	2.9%	7.5%	8.3%	5.6%	11.9%
idling/standing still	%	9.3%	13.9%	2.8%	0.4%	1.8%	11.6%	0.0%	1.6%	13.4%	0.9%	15.6%
final soak	%	1.4%	4.6%	3.9%	0.1%	0.3%	0.0%	18.8%	0.1%	0.1%	6.1%	0.0%
<b>speeds</b>												
avg time-based	km/h	43.7	20.2	31.0	37.9	68.6	49.8	16.2	68.5	46.8	21.5	44.3
avg braking speed	km/h	41.6	32.4	42.5	45.3	57.0	48.4	15.3	56.2	55.2	22.2	37.2
95 <sup>th</sup> percentile (1 Hz)	km/h	74.9	51.3	72.9	58.3	91.8	91.2	21.2	96.9	82.7	29.6	74.5
95 <sup>th</sup> percentile braking speed	km/h	83.9	55.1	73.9	58.8	96.0	91.9	20.6	91.0	77.2	29.1	81.5
maximum	km/h	132.5	59.6	79.7	59.5	98.4	105.2	21.2	96.9	83.6	29.6	132.5
<b>braking events</b>												
total	#	303	29	42	28	18	49	2	6	8	7	114
total/km	#/km	1.58	4.83	2.76	2.39	0.61	1.32	1.44	0.45	0.86	1.79	1.76
Complete stops	#	92	14	13	2	6	10	1	2	4	3	37
Braking snubs	#	211	15	29	26	12	39	1	4	4	4	77
Complete stops	%	30.4%	48.3%	31.0%	7.1%	33.3%	20.4%	50.0%	33.3%	50.0%	42.9%	32.5%
Braking snubs	%	69.6%	51.7%	69.0%	0.9	66.7%	79.6%	50.0%	66.7%	50.0%	57.1%	67.5%
<b>Braking events per initial speed bins (km/h)</b>												
0-15	#	25	2	1	0	0	1	1	0	0	1	19
15-25	#	57	8	8	0	5	9	1	1	1	3	21
25-40	#	76	10	10	12	1	12	0	1	0	3	27
40-60	#	94	9	15	16	2	14	0	1	4	0	33
60-100	#	46	0	8	0	10	11	0	3	3	0	11
100+	#	5	0	0	0	0	2	0	0	0	0	3
0-15	%	8.3%	6.9%	2.4%	0.0%	0.0%	2.0%	50.0%	0.0%	0.0%	14.3%	16.7%
15-25	%	18.8%	27.6%	19.0%	0.0%	27.8%	18.4%	50.0%	16.7%	12.5%	42.9%	18.4%
25-40	%	25.1%	34.5%	23.8%	42.9%	5.6%	24.5%	0.0%	16.7%	0.0%	42.9%	23.7%
40-60	%	31.0%	31.0%	35.7%	57.1%	11.1%	28.6%	0.0%	16.7%	50.0%	0.0%	28.9%
60-100	%	15.2%	0.0%	19.0%	0.0%	55.6%	22.4%	0.0%	50.0%	37.5%	0.0%	9.6%
100+	%	1.7%	0.0%	0.0%	0.0%	0.0%	4.1%	0.0%	0.0%	0.0%	0.0%	2.6%
<b>deceleration only</b>												
minimum	m/s <sup>2</sup>	0.49	0.58	0.64	0.63	0.64	0.63	0.65	0.82	0.70	0.58	0.49
50 <sup>th</sup> percentile	m/s <sup>2</sup>	0.91	0.92	0.94	0.88	0.85	1.01	0.65	1.08	0.98	0.75	0.86
95 <sup>th</sup> percentile	m/s <sup>2</sup>	1.35	1.50	1.67	1.27	1.70	1.34	0.66	1.66	1.54	1.15	1.44
maximum	m/s <sup>2</sup>	2.18	1.75	2.18	1.65	1.82	1.64	0.66	1.72	1.55	1.18	1.95
<b>Stop/Snub Duration</b>												
minimum	s	2.0	3.0	3.0	3.0	3.0	2.0	4.0	5.0	3.0	4.0	2.0
50 <sup>th</sup> percentile	s	5.0	6.0	5.0	4.0	6.0	5.0	4.5	8.5	6.0	5.0	5.0
95 <sup>th</sup> percentile	s	11.0	10.0	11.0	6.0	15.0	10.0	5.0	12.3	14.0	7.0	11.0
maximum	s	15.0	10.0	13.0	7.0	15.0	13.0	5.0	13.0	15.0	7.0	15.0
<b>distance traveled</b>	km	192.2	6.0	15.2	11.7	29.3	37.2	1.4	13.4	9.2	3.9	64.8
<b>Kinetic Energy deceleration (per kg of vehicle mass)</b>												
minimum	J	25	78	96	203	108	97	45	136	284	55	25
50 <sup>th</sup> percentile	J	455	404	500	510	784	680	112	1665	678	238	371
95 <sup>th</sup> percentile	J	1442	1032	1813	894	4337	1464	173	2365	3019	414	1832
maximum	J	8199	1181	2896	1092	4838	2614	180	2483	3497	438	8199
total/cycle	J	207134	13625	28272	14554	24333	34425	225	8562	9481	1663	71995
% of cycle		100%	6.6%	13.6%	7.0%	11.7%	16.6%	0.1%	4.1%	4.6%	0.8%	34.8%
total/distance	J/km	1078	2270	1861	1244	830	924	162	639	1025	424	1112
total/time	J/h	47129	45840	57665	47117	56993	46053	2629	43720	48007	9143	49199
<b>braking power (per kg of vehicle mass)</b>												
minimum	kW	0.006	0.016	0.022	0.068	0.022	0.029	0.011	0.027	0.041	0.011	0.006
50 <sup>th</sup> percentile	kW	0.095	0.077	0.105	0.115	0.154	0.103	0.024	0.161	0.146	0.051	0.078
95 <sup>th</sup> percentile	kW	0.223	0.150	0.227	0.186	0.289	0.340	0.035	0.251	0.225	0.062	0.284
maximum	kW	0.547	0.171	0.247	0.194	0.323	0.373	0.036	0.252	0.233	0.063	0.547
total/cycle	kW	33.777	2.204	4.757	3.439	2.687	6.904	0.047	0.924	1.172	0.305	11.338
% of cycle		100%	6.5%	14.1%	10.2%	8.0%	20.4%	0.1%	2.7%	3.5%	0.9%	33.6%
total/distance	kW/km	0.18	0.37	0.31	0.29	0.09	0.19	0.03	0.07	0.13	0.08	0.18
total/time	kW/h	7.69	7.41	9.70	11.13	6.29	9.24	0.55	4.72	5.93	1.68	7.75

**Table 4 – Metrics for the entire WLTP-Brake Cycle and each trip**

Trip #	Event #		Time stamps / s			Deceleration event					
						Trip			Brake speed		
						Cycle	Trip	Time / s	Initial / km/h	Final / km/h	Decel / m/s <sup>2</sup>
1	1	1	18	18	24	6	20.7	0.0	0.96		
1	2	2	58	58	65	7	23.1	5.6	0.70		
1	3	3	85	85	89	4	15.4	4.4	0.76		
1	4	4	103	103	109	6	25.7	7.2	0.86		
1	5	5	129	129	132	3	24.8	16.7	0.75		
1	6	6	140	140	149	9	18.7	0.0	0.58		
1	7	7	177	177	183	6	32.5	0.0	1.51		
1	8	8	298	298	303	5	27.5	11.8	0.87		
1	9	9	314	314	320	6	29.4	9.7	0.92		
1	10	10	341	341	347	6	31.9	9.5	1.04		
1	11	11	361	361	366	5	14.7	0.0	0.81		
1	12	12	384	384	388	4	59.5	47.6	0.82		
1	13	13	402	402	406	4	47.6	36.2	0.79		
1	14	14	486	486	490	4	38.2	25.5	0.88		
1	15	15	493	493	496	3	25.5	18.4	0.66		
1	16	16	499	499	505	6	18.4	0.0	0.85		
1	17	17	543	543	552	9	42.3	0.0	1.31		
1	18	18	566	566	576	10	42.1	0.0	1.17		
1	19	19	592	592	595	3	31.3	12.5	1.75		
1	20	20	600	600	605	5	12.5	0.0	0.69		
1	21	21	647	647	657	10	45.3	0.0	1.26		
1	22	22	673	673	683	10	45.5	0.0	1.27		
1	23	23	726	726	733	7	40.7	12.8	1.11		
1	24	24	747	747	751	4	59.6	46.7	0.89		
1	25	25	768	768	777	9	48.6	0.0	1.50		
1	26	26	941	941	945	4	23.7	9.8	0.97		
1	27	27	974	974	983	9	37.5	0.0	1.16		
1	28	28	996	996	1005	9	37.7	0.0	1.16		
1	29	29	1016	1016	1021	5	18.6	0.0	1.04		
2	30	1	1122	52	56	4	13.8	0.0	0.96		
2	31	2	1147	77	81	4	34.2	18.9	1.06		
2	32	3	1174	104	108	4	32.9	23.3	0.66		
2	33	4	1188	118	121	3	25.6	18.5	0.65		
2	34	5	1209	139	147	8	38.7	0.0	1.34		
2	35	6	1253	183	186	3	48.4	40.6	0.73		
2	36	7	1282	212	216	4	42.4	30.3	0.84		
2	37	8	1290	220	225	5	30.3	13.7	0.92		
2	38	9	1319	249	255	6	40.0	20.0	0.93		
2	39	10	1334	264	268	4	29.7	18.9	0.75		
2	40	11	1448	378	381	3	24.5	17.5	0.64		
2	41	12	1482	412	421	9	42.0	0.0	1.30		
2	42	13	1515	445	449	4	22.0	11.8	0.70		
2	43	14	1539	469	477	8	32.4	6.1	0.91		
2	44	15	1597	527	535	8	34.8	0.0	1.21		
2	45	16	1662	592	605	13	76.1	0.0	1.63		
2	46	17	1689	619	624	5	22.8	0.0	1.27		
2	47	18	1753	683	687	4	41.6	27.2	1.00		
2	48	19	1804	734	737	3	47.9	35.2	1.18		
2	49	20	1823	753	758	5	35.2	20.1	0.84		
2	50	21	1870	800	803	3	59.2	49.5	0.90		
2	51	22	1895	825	828	3	72.9	62.0	1.01		
2	52	23	1907	837	840	3	66.4	57.4	0.83		
2	53	24	1918	848	851	3	60.0	52.1	0.73		
2	54	25	1951	881	884	3	79.7	72.1	0.70		
2	55	26	1972	902	908	6	74.0	52.4	1.00		
2	56	27	2062	992	1004	12	52.4	0.0	1.21		
2	57	28	2123	1053	1063	10	60.3	0.0	1.68		
2	58	29	2187	1117	1125	8	62.9	0.0	2.18		
2	59	30	2218	1148	1159	11	60.1	15.2	1.13		
2	60	31	2250	1180	1191	11	53.3	0.0	1.35		
2	61	32	2520	1450	1456	6	20.7	0.0	0.96		
2	62	33	2560	1490	1497	7	23.1	5.6	0.70		
2	63	34	2587	1517	1521	4	15.4	4.4	0.76		
2	64	35	2605	1535	1541	6	25.7	7.2	0.86		
2	65	36	2631	1561	1564	3	24.8	16.7	0.75		
2	66	37	2642	1572	1580	8	18.7	0.0	0.65		
2	67	38	2672	1602	1607	5	46.6	9.4	2.07		
2	68	39	2698	1628	1631	3	52.0	41.5	0.97		
2	69	40	2714	1644	1649	5	49.9	34.0	0.88		
2	70	41	2738	1668	1675	7	49.0	23.8	1.00		
2	71	42	2759	1689	1697	8	41.6	0.0	1.45		

Trip #	Event #		Time stamps / s			Deceleration event					
						Trip			Brake speed		
						Cycle	Trip	Time / s	Initial / km/h	Final / km/h	Decel / m/s <sup>2</sup>
3	72	1	2897	62	68	6	32.1	5.5	1.23		
3	73	2	2946	111	114	3	50.5	42.8	0.71		
3	74	3	2958	123	128	5	45.0	29.8	0.84		
3	75	4	2966	131	136	5	29.8	0.0	1.65		
3	76	5	3006	171	176	5	49.2	33.1	0.89		
3	77	6	3032	197	201	4	56.2	44.0	0.84		
3	78	7	3053	218	221	3	59.0	51.2	0.72		
3	79	8	3078	243	246	3	55.0	47.5	0.69		
3	80	9	3096	261	266	5	59.5	39.9	1.09		
3	81	10	3159	324	330	6	39.9	14.2	1.19		
3	82	11	3195	360	366	6	58.3	34.8	1.09		
3	83	12	3268	433	436	3	39.5	30.0	0.88		
3	84	13	3308	473	476	3	56.2	46.0	0.94		
3	85	14	3418	583	587	4	54.4	40.4	0.97		
3	86	15	3441	606	610	4	53.5	40.8	0.88		
3	87	16	3480	645	648	3	40.8	32.0	0.81		
3	88	17	3492	657	660	3	34.7	26.4	0.78		
3	89	18	3557	722	726	4	50.6	37.6	0.90		
3	90	19	3621	786	791	5	37.6	22.4	0.84		
3	91	20	3647	812	816	4	36.8	22.9	0.96		
3	92	21	3684	849	853	4	55.3	39.5	1.10		
3	93	22	3692	857	863	6	39.5	15.5	1.11		
3	94	23	3729	894	897	3	44.3	36.6	0.71		
3	95	24	3773	938	943	5	36.6	20.8	0.88		
3	96	25	3849	1014	1017	3	32.0	24.8	0.66		
3	97	26	3879	1044	1048	4	51.6	39.3	0.86		
3	98	27	3895	1060	1063	3	39.3	32.4	0.63		
3	99	28	3939	1104	1111	7	32.4	0.0	1.29		
4	100	1	4001	54	58	4	75.8	63.9	0.83		
4	101	2	4089	142	146	4	72.4	58.7	0.96		
4	102	3	4118	171	175	4	65.9	53.7	0.85		
4	103	4	4147	200	210	10	54.9	0.0	1.52		
4	104	5	4551	604	619	15	90.6	0.0	1.68		
4	105	6	4668	721	736	15	95.6	25.5	1.30		
4	106	7	5004	1057	1072	15	98.4	0.0	1.82		
4	107	8	5071	1124	1129	5	82.8	69.4	0.75		
4	108	9	5135	1188	1202	14	69.4	10.1	1.18		
4	109	10	5190	1243	1246	3	69.0	61.7	0.67		
4	110	11	5297	1350	1353	3	64.7	57.8	0.64		
4	111	12	5314	1367	1379	12	57.8	0.0	1.34		
4	112	13	5350	1403	1409	6	20.7	0.0	0.96		
4	113	14	5390	1443	1450	7	23.1	5.6	0.70		
4	114	15	5417	1470	1474	4	15.4	4.4	0.76		
4	115	16	5435	1488	1494	6	25.7	7.2	0.86		
4	116	17	5461	1514	1517	3	24.8	16.7	0.75		
4	117	18	5472	1525	1533	8	18.7	0.0	0.65		
5	118	1	5514	30	40	10	41.8	0.0	1.16		
5	119	2	5554	70	73	3	34.6	27.3	0.68		
5	120	3	5571	87	97	10	43.5	0.0	1.21		
5	121	4	5624	140	145	5	30.0	13.6	0.91		
5	122	5	5647	163	172	9	37.0	0.0	1.14		
5	123	6	5749	265	269	4	41.2	29.5	0.81		
5	124	7	5789	305	308	3	29.5	18.0	1.07		
5	125	8	5795	311	316	5	18.0	0.0	1.00		
5	126	9	5814	330	333	3	29.5	22.1	0.68		
5	127	10	5820	336	340	4	22.1	8.1	0.97		
5	128	11	5844	360	365	5	16.9	0.0	0.94		
5	129	12	5965	481	484	3	14.4	3.5	1.01		
5	130	13	6074	590	594	4	56.4	41.2	1.06		
5	131	14	6081	597	604	7	41.2	13.9	1.08		
5	132	15	6175	691	696	5	56.4	41.3	0.84		
5	133	16	6208	724	729	5	58.0	39.6	1.02		
5	134	17	6248	764	768	4	39.6	22.3	1.20		
5	135	18	6320	836	846	10	26.7	0.0	0.74		
5	136	19	6872	1388	1392	4	105.2	90.4	1.03		
5	137	20	6898	1414	1417	3	102.2	91.6	0.98		
5	138	21	6930	1446	1448	2	94.6	87.2	1.04		
5	139	22	6953	1469	1473	4	87.2	72.3	1.03		
5	140	23	6977	1493	1497	4	84.8	73.8	0.77		

**(continued) Table 4 – Metrics for the entire WLTP-Brake Cycle and each trip**

Trip #	Event #		Time stamps / s			Deceleration event			
			Trip			Brake speed			
	Cycle	Trip	Cycle	Start	End	Time / s	Initial / km/h	Final / km/h	Decel / m/s <sup>2</sup>
5	141	24	6999	1515	1521	6	87.8	69.0	0.87
5	142	25	7069	1585	1590	5	69.0	50.2	1.04
5	143	26	7114	1630	1633	3	83.5	71.3	1.13
5	144	27	7177	1693	1698	5	71.3	53.5	0.99
5	145	28	7201	1717	1721	4	80.0	66.0	0.97
5	146	29	7346	1862	1865	3	66.0	56.7	0.86
5	147	30	7381	1897	1904	7	83.9	42.5	1.64
5	148	31	7442	1958	1971	13	73.8	24.4	1.06
5	149	32	7490	2006	2012	6	24.4	0.0	1.13
5	150	33	7518	2034	2038	4	22.9	13.5	0.65
5	151	34	7534	2050	2053	3	23.0	15.4	0.70
5	152	35	7548	2064	2067	3	19.0	12.2	0.63
5	153	36	7561	2077	2083	6	18.8	0.0	0.87
5	154	37	7704	2220	2225	5	37.9	24.4	0.75
5	155	38	7748	2264	2268	4	24.4	14.9	0.66
5	156	39	7769	2285	2290	5	45.3	25.9	1.08
5	157	40	7795	2311	2316	5	40.6	25.4	0.85
5	158	41	7817	2333	2338	5	37.2	20.8	0.91
5	159	42	7883	2399	2405	6	26.3	0.0	1.22
5	160	43	7907	2423	2429	6	53.4	28.2	1.17
5	161	44	7941	2457	2463	6	42.6	19.0	1.09
5	162	45	7973	2489	2495	6	57.1	31.8	1.17
5	163	46	8064	2580	2585	5	50.0	24.4	1.42
5	164	47	8081	2597	2604	7	58.2	29.9	1.12
5	165	48	8120	2636	2639	3	29.9	21.2	0.80
5	166	49	8168	2684	2690	6	32.6	0.0	1.51
6	167	1	8413	238	243	5	21.2	9.5	0.65
6	168	2	8421	246	250	4	9.5	0.0	0.66
7	169	1	8552	69	77	8	35.1	5.5	1.03
7	170	2	8609	126	131	5	16.5	0.0	0.92
7	171	3	9081	598	606	8	96.9	73.3	0.82
7	172	4	9117	634	644	10	73.3	20.1	1.48
7	173	5	9146	663	672	9	62.2	6.6	1.72
7	174	6	9174	691	704	13	53.2	0.0	1.14
8	175	1	9264	76	91	15	83.6	0.0	1.55
8	176	2	9375	187	194	7	23.9	0.0	0.95
8	177	3	9427	239	251	12	65.3	0.0	1.51
8	178	4	9489	301	305	4	40.5	29.3	0.78
8	179	5	9812	624	627	3	63.0	52.2	1.01
8	180	6	9845	657	660	3	52.2	44.6	0.70
8	181	7	9864	676	681	5	59.2	45.2	0.78
8	182	8	9888	700	710	10	53.9	0.0	1.50
9	183	1	10036	137	142	5	19.1	6.4	0.70
9	184	2	10049	150	155	5	10.5	0.0	0.58
9	185	3	10273	374	381	7	29.6	0.0	1.18
9	186	4	10453	554	559	5	24.3	4.5	1.10
9	187	5	10475	576	580	4	27.8	17.3	0.73
9	188	6	10482	583	587	4	17.3	6.5	0.75
9	189	7	10507	608	615	7	26.8	0.0	1.06
10	190	1	10638	84	93	9	27.5	0.0	0.85
10	191	2	10696	142	146	4	39.0	29.0	0.69
10	192	3	10721	167	171	4	35.1	24.5	0.74
10	193	4	10758	204	207	3	41.9	34.1	0.72
10	194	5	10792	238	243	5	39.4	24.9	0.81
10	195	6	10811	257	268	11	36.4	0.0	0.92
10	196	7	10868	314	325	11	55.7	0.0	1.41
10	197	8	11088	534	547	13	56.2	0.0	1.20
10	198	9	11117	563	572	9	43.6	0.0	1.35
10	199	10	11245	691	695	4	11.2	4.1	0.49
10	200	11	11261	707	711	4	15.0	6.2	0.61
10	201	12	11276	722	727	5	10.1	0.0	0.56
10	202	13	11313	759	762	3	31.3	23.8	0.69
10	203	14	11348	794	797	3	23.8	16.9	0.64
10	204	15	11354	800	807	7	16.9	0.0	0.67
10	205	16	11512	958	965	7	40.0	10.6	1.17
10	206	17	11541	987	991	4	15.6	6.3	0.65
10	207	18	11557	1003	1006	3	15.6	8.8	0.64
10	208	19	11574	1020	1025	5	13.1	0.0	0.73
10	209	20	11659	1105	1108	3	23.1	15.0	0.75
10	210	21	11669	1115	1117	2	18.1	13.6	0.63

Trip #	Event #		Time stamps / s			Deceleration event			
			Trip			Brake speed			
	Cycle	Trip	Cycle	Start	End	Time / s	Initial / km/h	Final / km/h	Decel / m/s <sup>2</sup>
10	211	22	11684	1130	1133	3	19.4	11.5	0.73
10	212	23	11690	1136	1140	4	11.5	0.0	0.80
10	213	24	11845	1291	1294	3	34.9	27.9	0.65
10	214	25	11861	1307	1311	4	43.7	32.1	0.80
10	215	26	11868	1314	1319	5	32.1	12.4	1.10
10	216	27	11880	1326	1330	4	12.4	0.0	0.86
10	217	28	12067	1513	1518	5	14.7	0.0	0.81
10	218	29	12082	1528	1532	4	13.8	0.0	0.96
10	219	30	12103	1549	1552	3	12.4	0.0	1.14
10	220	31	12132	1578	1586	8	18.7	0.0	0.65
10	221	32	12181	1627	1633	6	18.4	0.0	0.85
10	222	33	12198	1644	1648	4	41.2	30.4	0.75
10	223	34	12208	1654	1659	5	30.4	14.8	0.86
10	224	35	12267	1713	1718	5	50.5	30.8	1.09
10	225	36	12276	1722	1730	8	30.8	0.0	1.07
10	226	37	12336	1782	1786	4	12.4	0.0	0.86
10	227	38	12364	1810	1814	4	14.7	0.0	1.02
10	228	39	12461	1907	1915	8	18.7	0.0	0.65
10	229	40	12487	1933	1939	6	18.4	0.0	0.85
10	230	41	12510	1956	1960	4	13.8	0.0	0.96
10	231	42	12524	1970	1974	4	12.4	0.0	0.86
10	232	43	12552	1998	2002	4	14.7	0.0	1.02
10	233	44	12614	2060	2063	3	105.0	95.4	0.89
10	234	45	12622	2068	2072	4	95.4	82.4	0.90
10	235	46	12642	2088	2092	4	97.4	82.7	1.03
10	236	47	12651	2097	2100	3	82.7	74.5	0.76
10	237	48	12658	2104	2114	10	74.5	38.7	0.99
10	238	49	12695	2141	2148	7	64.0	25.9	1.51
10	239	50	12714	2160	2164	4	47.8	36.0	0.82
10	240	51	12790	2236	2242	6	60.3	36.4	1.11
10	241	52	12854	2300	2304	4	49.0	37.0	0.83
10	242	53	12926	2372	2378	6	61.0	28.0	1.53
10	243	54	12959	2405	2411	6	43.2	25.0	0.84
10	244	55	12977	2423	2426	3	46.7	37.9	0.81
10	245	56	13053	2499	2506	7	54.9	22.4	1.29
10	246	57	13072	2518	2521	3	26.2	18.6	0.70
10	247	58	13084	2530	2536	6	20.1	7.0	0.60
10	248	59	13093	2539	2543	4	7.0	0.0	0.49
10	249	60	13175	2621	2625	4	28.0	16.3	0.81
10	250	61	13188	2634	2638	4	18.6	7.6	0.76
10	251	62	13273	2719	2724	5	28.7	14.6	0.78
10	252	63	13290	2736	2740	4	22.9	12.0	0.76
10	253	64	13334	2780	2790	10	46.0	0.0	1.28
10	254	65	13379	2825	2830	5	46.2	32.1	0.78
10	255	66	13408	2854	2858	4	32.1	20.8	0.79
10	256	67	13442	2888	2891	3	20.8	12.4	0.78
10	257	68	13482	2928	2934	6	42.5	17.8	1.15
10	258	69	13498	2944	2952	8	22.7	0.0	0.79
10	259	70	13521	2967	2970	3	25.0	17.2	0.72
10	260	71	13535	2981	2985	4	30.9	16.7	0.98
10	261	72	13578	3024	3029	5	43.0	29.8	0.73
10	262	73	13633	3079	3082	3	58.8	48.7	0.94
10	263	74	13639	3085	3091	6	48.7	23.8	1.15
10	264	75	13676	3122	3127	5	44.3	30.3	0.78
10	265	76	13716	3162	3166	4	41.4	28.4	0.90
10	266	77	13739	3185	3191	6	51.4	32.0	0.90
10	267	78	13748	3194	3200	6	32.0	10.0	1.02
10	268	79	13760	3206	3211	5	10.0	0.0	0.56
10	269	80	13775	3221	3226	5	16.3	0.0	0.91
10	270	81	13817	3263	3268	5	45.8	28.6	0.96
10	271	82	13836	3282	3287	5	40.9	25.4	0.86
10	272	83	13853	3299	3302	3	41.1	30.7	0.96
10	273	84	13862	3308	3311	3	30.7	22.1	0.80
10	274	85	13878	3324	3327	3	28.2	21.2	0.65
10	275	86	13956	3402	3405	3	37.6	29.8	0.72
10	276	87	13975	3421					

**(continued) Table 4 – Metrics for the entire WLTP-Brake Cycle and each trip**

Trip #	Event #		Time stamps / s			Deceleration event			
			Trip			Brake speed			
	Cycle	Trip	Cycle	Start	End	Time / s	Initial / km/h	Final / km/h	Decel / m/s <sup>2</sup>
10	281	92	14138	3584	3588	4	26.3	16.5	0.68
10	282	93	14150	3596	3600	4	19.0	7.6	0.79
10	283	94	14157	3603	3607	4	7.6	0.0	0.53
10	284	95	14175	3621	3626	5	32.2	13.6	1.04
10	285	96	14189	3635	3641	6	13.6	0.0	0.63
10	286	97	14266	3712	3716	4	24.9	10.9	0.98
10	287	98	14277	3723	3727	4	10.9	0.0	0.75
10	288	99	14290	3736	3740	4	11.0	0.0	0.77
10	289	100	14325	3771	3779	8	64.9	25.5	1.37
10	290	101	14992	4438	4447	9	112.0	56.1	1.72
10	291	102	15013	4459	4467	8	68.2	12.0	1.95
10	292	103	15048	4494	4503	9	80.9	35.3	1.41
10	293	104	15076	4522	4529	7	73.4	39.3	1.36
10	294	105	15086	4532	4544	12	39.3	0.0	0.91
10	295	106	15457	4903	4918	15	132.5	34.0	1.82
10	296	107	15482	4928	4937	9	41.6	0.0	1.28
10	297	108	15584	5030	5036	6	33.1	6.3	1.24
10	298	109	15625	5071	5082	11	37.6	0.0	0.95
10	299	110	15664	5110	5121	11	52.0	0.0	1.31
10	300	111	15717	5163	5170	7	50.6	22.9	1.10
10	301	112	15742	5188	5195	7	47.7	23.4	0.96
10	302	113	15791	5237	5243	6	45.9	23.6	1.03
10	303	114	15815	5261	5268	7	37.6	0.0	1.49

### 8.5 Time-resolved trips and 1 Hz speed profiles

A copy of the spreadsheet with the 1 Hz speed traces can be found and downloaded at <https://data.mendeley.com/datasets/dkp376g3m8/1> (Mathissen et al., 2018b).

## 9 Test reports

This section describes the two main outputs of the brake inertia dynamometer test, EEC and EED files. These file formats are agnostic to the control technology and software and allow other stakeholders to have direct access to the test outputs. Other elements of the test report might include the following:

- The test facility, brake inertia dynamometer identification, test number, testing dates, test requestor, key laboratory staff involved in the test, and main instruments used for brake emission measurements;
- Description of the main parameters and settings for cooling air and sampling system;
- Description of the vehicle application, brake hardware and sizes or dimensions, friction material edge codes, wheel load, tire size or tyre dynamic rolling radius;
- The initial and final wear measurements for brake hardware, when instructed by the test requestor;
- Digital pictures of test parts;
- Notes and comments from the laboratory personnel documenting any unique aspects, observations, or deviations during the test.

NOTE: Part 3 of the PMP Brake Protocol will provide the minimum requirements and guidelines to report results for PM and PN, as well as summary metrics to allow the comparability among tests.

### 9.1 EEC files

When requested, use the VDA 305 standard to generate a CSV or MS Excel™ file for the entire test with one row for each brake deceleration event. See Annex C for a sample section of the file. In addition to section or event markers, the EEC file includes timestamps, and values corresponding to initial, final, average, minimum, and maximum level for different control and output variables.



## 9.2 EED files

When requested, use the VDA 305 standard to generate a CSV or MS Excel™ file with the entire test with data sampling at 1 Hz. Include at least the following parameters: trip #, timestamp, setpoint and limits for brake speed. An example of how an EED file looks like is given in Table 5. For the actual cycle include at a minimum:

- dynamometer time marker at 1 Hz;
- brake speed;
- deceleration;
- brake torque;
- brake pressure
- friction coefficient
- brake temperatures
- cooling *airstream speed*
- *cooling air* temperature and humidity.

NOTE: The rate for the EED file is slower than the actual sampling rates for the test to avoid excessive data processing times and to generate large files

**Table 5 – Example of the first 20 seconds of an EED file per VDA 305**

Trip	Time #s	time s	BrkSpd kph	Dcl m/s <sup>2</sup>	T N·m	P kPa	Mu μ	R_Rotor °C	E_Rotor °C	OP °C	IP °C	CASpd kph	CATemp °C	CArh %RH
1	1	1682	0	0	7.1	-3.8	0	18.2	21.9	19	19.4	9.7	16.3	47.1
1	2	1683	0	0	7.5	-3	0	18.1	21.9	19	19.4	11.3	16.3	46.9
1	3	1684	0	0	7.9	-3	0	18.1	22	19	19.3	12.7	16.3	46.7
1	4	1685	0	0	8.2	-1.4	0	18	21.9	19	19.4	13.9	16.3	46.4
1	5	1686	1.42	0	7.9	-3.8	0	17.9	21.9	19	19.3	15.2	16.3	46.2
1	6	1687	5.14	0	7.9	-3.8	0	17.9	21.9	19	19.4	16	16.2	46.1
1	7	1688	8.75	0	8	-4.5	0	18.1	21.9	19	19.4	17.1	16.2	46.1
1	8	1689	12.28	0	9.1	-3.8	0	18.2	21.7	19	19.3	17.7	16.2	46.2
1	9	1690	15.78	0	8.8	-3	0	18.4	21.7	19	19.4	17.9	16.2	46.4
1	10	1691	19.17	0	8.6	-2.2	0	18.6	21.9	19	19.4	19	16.2	46.4
1	11	1692	21.21	0	8.4	-3.8	0	18.8	21.7	19	19.3	19.3	16.2	46.6
1	12	1693	20.96	0	8.6	-3.8	0	18.9	21.8	19	19.3	19.9	16.2	46.7
1	13	1694	20.84	0	8.8	-3.8	0	19	21.7	19	19.3	20.7	16.2	46.8
1	14	1695	20.78	0	8.6	-3	0	19	21.8	18.9	19.4	21.1	16.1	46.9
1	15	1696	20.76	0	8.8	-3	0	19	21.6	19	19.3	21.5	16.1	47
1	16	1697	20.74	0	8.9	-3	0	18.9	21.3	18.9	19.3	21.4	16.1	47.1
1	17	1698	20.71	0	8.6	-3	0	18.9	20.9	18.9	19.3	22.5	16.1	47.2
1	18	1699	20.7	0	8.2	-3.8	0	18.9	21.1	19	19.3	22.3	16.1	47.3
1	19	1700	20.55	0	8	-3.8	0	18.9	21.3	18.9	19.3	22.5	16.1	47.4
1	20	1701	18.48	0	13.6	302.1	0	18.8	21.5	18.9	19.3	23.2	16	47.5
1	21	1702	14.97	0	172.1	1128	0.265	19.1	22.8	19	19.3	23.4	16.1	47.6
1	22	1703	11.43	0	168.7	1155.9	0.253	20.1	23.8	19.5	19.6	23.4	16	47.7
1	23	1704	7.91	0	169.4	1160.6	0.253	21	24.2	20.1	20	23.7	16	47.8
1	24	1705	4.47	0	171	1170.7	0.253	21.4	24.7	20.9	20.3	23.9	16	47.9

## Annex A (informative)

### Technical specification of reference vehicles and brakes used to validate the cooling airstream speed adjustment

Table A.1 illustrates the primary vehicle and brake parameters for the vehicles used to develop and validate the cooling airstream speed on clause 7. Use the list to determine equivalent brake sizes per item 4.52. for internal or interlaboratory studies and testing campaigns.

**Table A.1 – Reference vehicle and brake parameters for WLTP-Brake Cycle**

Vehicle [#]	Axle (-)	Pad (-)	Disc (-)	Disc outside Diameter (mm)	Disc Thickness (mm)	Inertia (kg·m <sup>2</sup> )	Vehicle test mass (kg)	Road Load Coefficients		
								A / f <sub>0</sub> [N]	B / f <sub>1</sub> [N/(km/h)]	C / f <sub>2</sub> [N/(km/h) <sup>2</sup> ]
#1	Front	NAO	Vented	260	20	52.6	1347	94.698	0.3287	0.0321
	Rear	N/A	N/A	See note 1		18.9				
#2	Front	NAO	Vented	295	28	79.7	1665	159.76 5	-0.0332	0.0344
	Rear	NAO	Solid	280	10	28.6				
#3	Front	NAO	Vented	290	26	84.6	1651	158.30 4	-0.4360	0.0481
	Rear	NAO	Vented	290	16	30.4				
#4	Front	NAO	Vented	330	28	99.0	2182	166.28 4	0.1055	0.0508
	Rear	NAO	Solid	310	10	48.0				
#5	Front	NAO	Vented	350	34	165.0	2617	208.30 0	2.1170	0.0538
	Rear	NAO	Vented	335	22	60.0				
#6	Front	LS	Vented	278	25	56.7	1600	118.40 0	1.5700	0.0300

Note 1: drum brake with an internal diameter of 200 mm and brake shoe with of 45 mm.

## Annex B (informative)

### Example of a step-by-step calculation of acceptance criteria for airstream speed

Table B.1 illustrates a numerical example on how to use the estimates from clause 7, applied on the front axle of vehicle #1. See Annex A.

**Table B.1 – Numerical example of temperature metrics for front axle on reference vehicle #1**

Event #	Metric	Column A Vehicle/Target [°C]	Column B Dynamometer [°C]	Column C Difference [°C]	Column D Acceptance [°C]
–	<i>Average brake temperature</i>	$A_1 = 85$	$B_1 = 80$	$C_1 = 5$	$C_1 \leq 10$
46			$Y_1 = 49$	n/a	n/a
101			$Y_2 = 33$	n/a	n/a
102			$Y_3 = 93$	n/a	n/a
103			$Y_4 = 89$	n/a	n/a
104			$Y_5 = 109$	n/a	n/a
106			$Y_6 = 85$	n/a	n/a
–	<i>Average IBT</i>	$A_2 = 85$	$B_2 = 76$	$C_2 = 9$	$C_2 \leq 15$
46			$Z_1 = 148$	n/a	n/a
101			$Z_2 = 101$	n/a	n/a
102			$Z_3 = 127$	n/a	n/a
103			$Z_4 = 115$	n/a	n/a
104			$Z_5 = 148$	n/a	n/a
106			$Z_6 = 94$	n/a	n/a
–	<i>Average FBT</i>	$A_3 = 135$	$B_3 = 122$	$C_3 = 13$	$C_3 \leq 25$
–	<i>Maximum temperature</i>	$A_4 = 170$	$B_4 = 157$	$C_4 = 13$	$C_4 \leq 25$



## Bibliography

Agudelo Carlos, Grigoratos Theodoros and Grochowicz Jarek. *"PMP Interlaboratory Accuracy Study for WLTP-Brake (novel) Inertia Dynamometer Duty Cycle"*. 37th SAE Annual Brake Colloquium & Exhibition September 22-25, 2019 Orlando, FL

Collier Sonya, Yoon Seungju, Long Jeff, Pournazeri Sam, Herner Jorn, Stanard Alan, Koupal John, Kishan Sandeep, Agudelo Carlos, Vedula Ravi, Bisrat Simon, Choi Yoojoong, Serrano Mauricio, et al. *"Brake-wear PM Research for California Emission Inventory"*. PMP 50<sup>th</sup> Session – April 03-04, 2019 Brussels – Available at: <https://wiki.unece.org/display/trans/PMP+50th+Session>

Grigoratos Theodoros and Martini Giorgio. *"Non-exhaust traffic related emissions – Brake and tyre wear PM"*; JRC Science and Policy Reports (2014). <http://publications.jrc.ec.europa.eu/repository/bitstream/111111111/31875/1/jrc89231-online%20final%20version%202.pdf>

Grigoratos Theodoros and Martini Giorgio. *"Brake wear particle emissions: A review"*; Environmental Science and Pollution Research 22 (2015) 2491–2504

Grochowicz Jarek, Agudelo Carlos and Grigoratos Theodoros. *"Initial Statistical Assessment TF1 Using ISO 5725 5 for Heterogenous Materials"*. PMP 50<sup>th</sup> Session – April 03-04, 2019 Brussels – Available at: <https://wiki.unece.org/display/trans/PMP+50th+Session>

Mathissen Marcel, Grochowicz Jaroslaw, Schmidt Christian, Vogt Rainer, Farwick zum Hagen Ferdinand, Grabiec Tomasz, Steven Heinz, and Grigoratos Theodoros. *"A novel real-world braking cycle for studying brake wear particle emissions"*; Wear 414 (2018a): 219-226

Mathissen Marcel, Grochowicz Jaroslaw, Schmidt Christian, Vogt Rainer, Farwick zum Hagen Ferdinand, Grabiec Tomasz, Steven Heinz, and Grigoratos Theodoros. *"WLTP-Based real-world Brake Wear Cycle"*; DOI: 10.17632/dkp376g3m8.1

VDA, *"VDA 5 — Quality Management in the Automotive Industry — Capability of Measurement Processes"*. Berlin: Verband der Automobilindustrie e.V. (VDA), 2011