

The text reproduced below reflects the state of play of the discussion of the SIG UNR157 up to its 8th meeting on raising the specified maximum speed of ALKS up to 130 km/h. It is based on ECE/TRANS/WP.29/GRVA/2020/32 (DE) and subsequent amendments received on this proposal.

Modifications to the existing text of UN-Regulation No. 157 (incl. suppl.02 to 00 series) are marked in **black bold** for new or ~~strike through~~ for deleted characters.

Comments:

- Changes to UNR157-08-03 are marked in **green bold** for new or ~~green strike through~~ for deleted characters.
- Agreements and group conclusions: highlighted in *grey & green*.
- Open points of discussions: highlighted in *yellow*.

05.10.2021: Correction of the equation in para. 3.4.2.2.1 of Annex 3 by JRC/EC

I. Proposal

Group conclusion on para. 2.1: agreed.

Paragraph 2.1., amend to read:

- 2.1. “Automated Lane Keeping System (ALKS)” ~~for low speed application~~ is a system which is activated by the driver and which keeps the vehicle within its lane for travelling speed of ~~60~~ **130** km/h or less by controlling the lateral and longitudinal movements of the vehicle for extended periods without the need for further driver input.

Within this Regulation, ALKS is also referred to as “*the system*”.

New definition for “string instability” agreed (to replace the two previous proposals):

Paragraph 2.21., insert to read:

- ~~2.21. “Stability of vehicle and driver system” is the ability of the system composed by the vehicle and the driver, either human or non-human, to recover the initial safe motion after a disturbance.~~
- ~~2.22. “String stability” is the capability of the ALKS vehicle to react to a perturbation in the speed profile of the vehicle in front, whose speed profile directly affects the speed profile of the ALKS vehicle, with a perturbation in its speed profile of lower or equal absolute magnitude.]~~
- 2.21. “*String instability*” is when a disturbance in the speed profile of the vehicle in front is amplified by the following vehicle.

Come back: JP proposal (UNR157-08-06) to include definitions for MRMLC (para. 2.23. to 2.29) -> agreed to discuss on 2nd day of 8th SIG with LC proposal.

Group conclusion on 5.1.1.1.: agreed.

Paragraph 5.1.1.1, insert to read:

- 5.1.1.1. The system shall demonstrate anticipatory behavior in interaction with other road user(s), in order to ensure stable, low-dynamic, longitudinal behavior and risk minimizing behavior when critical situations could become imminent, e.g. with pedestrians or cutting-in vehicles.

Group conclusion on 5.2.1: agreed.

Paragraph 5.2.1., amend to read:

5.2.1. The activated system shall keep the vehicle inside its lane of travel and ensure that the vehicle does not cross any lane marking (outer edge of the front tyre to outer edge of the lane marking). The system shall ~~drive smoothly~~, aiming to keep the vehicle in a stable lateral ~~and longitudinal~~ position ~~motion~~ inside the lane of travel to avoid confusing other road users ~~for requiring them to take unnecessary avoiding action.~~

The system shall aim to recover the initial original safe state of motion after disturbances not requiring an emergency manoeuvre.

Group conclusion on paragraph 5.2.: No change to 5.2. needed as already covered in WP.29/2021/17.

~~Paragraph 5.2. amend to read:~~

~~5.2. Dynamic Driving Task~~

~~The fulfilment of the provisions of this paragraph shall be demonstrated by the manufacturer to the technical service during the inspection of the safety approach as part of the assessment to Annex 4 (in particular for conditions not tested under Annex 5) and according to the relevant tests in Annex 5.~~

Come back to finalize discussion considering JP's proposal as 'Option A' (UNR157-08-06; amendments in blue) and OICA/CLEPA's proposal as 'Option B' (UNR157-08-12); Point of discussion on 5.2.3.1 in 7th SIG.: The group agreed the max speed of 60 km/h instead of originally proposed 100 km/h by industry for systems with no lane change capability during MRM. New text in [] proposed by industry to allow systems to operate at higher speeds without lane change capability during MRM in very limited circumstances.)

Paragraph 5.2.3.1., amend to read:

5.2.3.1. **Speed**

The manufacturer shall declare the specified maximum speed based on the forward detection range of the system as described in paragraph 7.1.1.

The maximum speed up to which the system is permitted to operate is ~~60~~ 130 km/h.

Option A:

Specified maximum speeds of more than 60km/h shall only be permissible if the ALKS is capable of bringing the vehicle to standstill ~~on in the hard shoulder~~ target stop area during an MRM according to paragraph 5.5.7. and its subparagraphs.

Option B (not yet discussed):

[Operational speeds of more than [60 km/h] are permitted either

- up to [90]km/h exclusively in the slowest lane of travel, provided there is surrounding traffic travelling at a similar speed (e.g. dense traffic or following a lead vehicle) or

- in all lanes of travel, if the ALKS is capable of changing lanes to bring the vehicle to a standstill outside of the regular lanes of travel during an MRM according to para. Xxx.

Systems that operate above 60 km/h up to [90]km/h without lane change capability shall implement strategies to minimize the risk of stopping in lane to the vehicle occupants and other road users, e.g. adapted deceleration strategy, operation only under good visibility.]

Group conclusion: amendments to para. 5.2.3.2. (coming from FR proposal) not needed due to amendment in para. 7.1.1. → para. 5.2.3.2. stays in its original version.

Paragraph 5.2.3.2., amend to read:

5.2.3.2. The activated system shall adapt the vehicle speed ~~and modify the dynamic performance of the vehicle including its deceleration potential~~ to infrastructural and environmental conditions (e.g. narrow curve radii, inclement weather).

Group conclusion on 5.2.3.3.: Agreed to keep table only up to 60 km/h. Values based on braking capabilities. For speeds above 60 km/h, the text refers to traffic rules. Agreed as part of string instability proposal.

Paragraph 5.2.3.3., amend to read:

5.2.3.3. The activated system shall detect the distance to the next vehicle in front as defined in paragraph 7.1.1. and shall adapt the vehicle speed **to adjust a safe following distance** in order to avoid a collision.

While the ALKS vehicle is not at standstill **and operating in speed range up to 60 km/h**, the system shall adapt the speed to adjust the distance to a vehicle in front in the same lane to be equal or greater than the minimum following distance **according to the table below**.

For speeds above 60 km/h the activated system shall comply with minimum following distances in the country of operation as defined in paragraph 5.1.2.

In case ~~the minimum time gap cannot be respected temporarily because of other road users~~ **this following distance to a vehicle in front is temporarily disrupted** (e.g. vehicle is cutting in, decelerating lead vehicle, etc.), the vehicle shall readjust the ~~minimum~~ following distance at the next available opportunity without any harsh braking **implementing strategies aiming to address significant string instability in order to not disrupt traffic flow**, unless an emergency manoeuvre would become necessary.

For speeds up to 60 km/h ~~the~~ the minimum following distance shall be calculated using the formula:

$$d_{\min} = v_{\text{ALKS}} * t_{\text{front}}$$

Where:

d_{\min} = the minimum following distance

v_{ALKS} = the present speed of the ALKS vehicle in m/s

t_{front} = minimum time gap in seconds between the ALKS vehicle and a leading vehicle in front as per the table below:

<i>Present speed of the ALKS vehicle</i>		<i>Minimum time gap</i>	<i>Minimum following distance</i>
(km/h)	(m/s)	(s)	(m)
7.2	2.0	1.0	2.0
10	2.78	1.1	3.1
20	5.56	1.2	6.7
30	8.33	1.3	10.8
40	11.11	1.4	15.6
50	13.89	1.5	20.8
60	16.67	1.6	26.7

For speed values **up to 60 km/h which are** not mentioned in the table, linear interpolation shall be applied.

Notwithstanding the result of the formula above for present speeds below 2 m/s the minimum following distance shall never be less than 2 m.

The requirements of this paragraph are without prejudice to other requirements in this Regulation, most notably paragraphs 5.2.4. and 5.2.5. with subparagraphs.

Group conclusion on 5.2.4.: Agreed to keep para. 5.2.4. in its original version → no change

5.2.4. The activated system shall be able to bring the vehicle to a complete stop behind a stationary vehicle, a stationary road user or a blocked lane of travel to avoid a collision. This shall be ensured up to the maximum operational speed of the system.

Group conclusion: New text in bold in 5.2.5. on a vehicle proceeding in opposite direction agreed and moved to 5.2.8. by leadership → Group confirmed new location of para. 5.2.8. and agreed slight rewording to fit with existing text; [] removed.

~~Paragraph 5.2.5., amend to read:~~

~~5.2.5. The activated system shall detect the risk of collision in particular with another road user ahead or beside the vehicle, due to a decelerating lead vehicle, a cutting in vehicle or a suddenly appearing obstacle and shall automatically perform appropriate manoeuvres to minimize risks to safety of the vehicle occupants and other road users.~~

~~Additionally the ALKS shall implement strategies to react to a vehicle proceeding in the opposite direction in the ALKS vehicle's lane of travel aiming to mitigate the effects of a potential collision with that vehicle.~~

Insert new paragraph 5.2.8., to read:

[5.2.8. In the situation where a vehicle is proceeding in the opposite direction in the ALKS vehicle's lane of travel, the ALKS shall implement strategies to react to the vehicle with the aim of mitigating the effects of a potential collision.]

Group conclusion: Para. 5.2.5.1. remains in its original version, since table for minimum following distance in para. 5.2.3.3. unchanged for ALKS up to 60 km/h → no change!

~~Paragraph 5.2.5.1, amend to read:~~

~~5.2.5.1. The activated system shall avoid a collision with a leading vehicle which decelerates up to its full braking performance provided that there was no undercut of the minimum following distance the ALKS vehicle would adjust to a leading vehicle at the present speed due to a cut in manoeuvre of this lead vehicle.~~

Group conclusion: Para. 5.2.5.2. to remain in its original version → no change! Proposed model by JRC/EC to be incorporated as guidance in Appendix 3 for the time being in addition to existing driver model.

5.2.5.2 The activated system shall avoid a collision with a cutting in vehicle

- (a) Provided the cutting in vehicle maintains its longitudinal speed which is lower than the longitudinal speed of the ALKS vehicle and
- (b) Provided that the lateral movement of the cutting in vehicle has been visible for a time of at least 0.72 seconds before the reference point for *TTCLaneIntrusion* is reached,
- (c) When the distance between the vehicle's front and the cutting in vehicle's rear corresponds to a TTC calculated by the following equation:

$$TTCLaneIntrusion > v_{rel}/(2 \cdot 6m/s^2) + 0.35s$$

Where:

v_{rel} = relative velocity between both vehicles, positive for vehicle being faster than the cutting in vehicle

$TTCLaneIntrusion$ = The TTC value, when the outside of the tyre of the intruding vehicle's front wheel closest to the lane

markings crosses a line 0.3 m beyond the outside edge of the visible lane marking to which the intruding vehicle is being drifted.

Group conclusion: Para. 5.2.5.3. agreed; [] around last sentence removed.

Paragraph 5.2.5.3., amend to read:

5.2.5.3. The activated system shall avoid a collision with an unobstructed crossing pedestrian in front of the vehicle.

In a scenario with an unobstructed pedestrian crossing with a lateral speed component of not more than 5 km/h where the anticipated impact point is displaced by not more than 0.2 m compared to the vehicle longitudinal center plane, the activated ALKS shall avoid a collision up to ~~the maximum operational speed of the system~~ **60 km/h**.

[At higher speeds, upon detection of pedestrians crossing the carriageway the ALKS shall implement strategies to reduce the potential for a collision.]

Group conclusion: Decision to include JRC/EC fuzzy logic model in UN-R 157-Annex 3 in addition to existing model reconfirmed and agreement to proposed amendments in para. 5.2.7.:

Paragraph 5.2.7., amend to read:

5.2.7. For conditions not specified in paragraphs 5.2.4., 5.2.5. or its subparagraphs, the performance of the system shall be ensured at least to the level at which a competent and careful human driver could minimize the risks. The attentive human driver performance models and related parameters in ~~the traffic~~ critical disturbance scenarios ~~from~~ **in** Annex 3 may be taken as guidance. The capabilities of the system shall be demonstrated in the assessment carried out under Annex 4.

Group conclusion: Delete proposed new para. 5.2.9 and 5.2.10.

Paragraph 5.2.9., insert to read:

~~[5.2.9. The stability of the vehicle and driver system is a necessary condition that must be always met, provided that effects of unplanned events disturbing the safe motion are within reasonable limits. This shall be demonstrated in the assessment of the tests carried out in accordance with Annex 4 and 5 of this Regulation]~~

Paragraph 5.2.10., insert to read:

~~[5.2.10. While following another vehicle the ALKS vehicle shall aim to be string stable.~~

~~In particular, when following another vehicle at constant speed and at a distance such that the speed profile of the ALKS vehicle is influenced by the speed profile of the vehicle in front, the ALKS vehicle shall aim to respond to a perturbation in the speed of the vehicle in front with a perturbation in its speed profile by at most a 5% increase in the maximum difference in speed compared to the vehicle in front before reaching a new equilibrium velocity following the visual examples reported in the following figures.~~

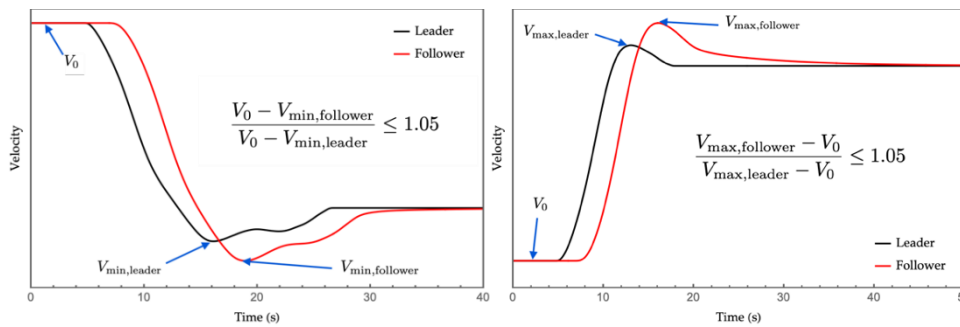

~~In addition, in the case when there is more than one ALKS vehicle in a chain following a vehicle under the conditions described in the previous paragraph, they shall aim to avoid further amplifying the perturbation caused by the lead vehicle from one vehicle to the next. The provisions included in this paragraph shall be demonstrated in accordance with Annex 4 of this Regulation.~~

Group conclusion for 5.3.2: Proposal. agreed.

Paragraph 5.3.2., amend to read:

5.3.2 This manoeuvre shall decelerate the vehicle up to its full braking performance if necessary and/or may perform an automatic evasive manoeuvre, when appropriate.

If failures are affecting the braking or steering performance of the system, the manoeuvre shall be carried out with consideration for the remaining performance.

During the evasive manoeuvre the ALKS vehicle shall not cross the lane marking (outer edge of the front tyre to outer edge of the lane marking).

After the evasive manoeuvre the vehicle shall aim at resuming a stable ~~position~~ **motion**.

Group conclusion: Para. 5.4.2. to remain in its original version. → no change!

Paragraph 5.4.2., amend to read:

5.4.2. The initiation of the transition demand shall be such that sufficient time is provided for a safe transition to manual driving.

Come back: Finalize discussion on JP proposal (UNR157-08-06, in blue); Point of discussion on para. 5.4.2.4. in 7th SIG: Text from JRC/EC (UNR157-03-06) to be confirmed (Reminder: definition for 'regular LCP' might need to be introduced, if inserted here as (new) term.)

Paragraph 5.4.2.4., insert to read:

5.4.2.4. In case the ALKS is capable to perform [a regular]LCP, it shall be aimed that [a regular] LCP is not part of the transition phase, meaning that the transition demand is not given shortly before or during a LCP.

Group conclusion on 5.4.2.3.: agreed.

Paragraph 5.4.2.3., amend to read:

5.4.2.3 In case of any failure affecting the ~~[operation of the system ability of the system to meet the requirements of this regulation]~~, the system shall immediately initiate a transition demand upon detection.

Come back: Consider JP's proposal (UNR157-08-06) to add/link MRMLC-relevant paragraphs (para. 5.5.1 and 5.5.7) with speed increase. (JP: The MRMLC function is indispensable for speed increase).

Group conclusion on 6.4.1.: agreed.

Paragraph 6.4.1. amend to read:

- 6.4.1. The following information shall be indicated to the driver:
- (a) The system status as defined in paragraph 6.4.2.
 - (b) Any failure affecting the **operation of the system ability of the system to meet the requirements of this regulation** with at least an optical signal unless the system is deactivated (off mode),
 - (c) Transition demand by at least an optical and in addition an acoustic and/or haptic warning signal.
- ...

Group conclusion on para. 7.1.1.: agreed with amendments below.

Paragraph 7.1.1., amend to read:

7.1.1. Forward detection range

The manufacturer shall declare the forward detection range measured from the forward most point of the vehicle. This declared value shall be at least 46 metres **for a specified maximum speed of 60 km/h.**

A specified maximum speed above 60 km/h shall only be declared by the manufacturer, if the declared forward detection range fulfils the corresponding minimum value according the following table based on deceleration of 5m/s²:

<i>Specified maximum speed / km/h</i>	<i>Minimum forward detection range / m</i>
0...60	46
70	50
80	60
90	75
100	90
110	110
120	130
130	150

For values not mentioned in the table, linear interpolation shall be applied.

It is recognized that the minimum forward detection range and vehicle deceleration of 5m/s² cannot be achieved under all conditions (e.g. on slippery roads). The system shall implement control strategies to adapt its maximum speed due the actual detection range and the actual deceleration capability to comply with paragraph 5.2.4. Those strategies shall be demonstrated and approved by the Technical Service.

The Technical Service shall verify that the distance at which the vehicle sensing system detects a road user during the relevant test in Annex 5 is equal or greater than the declared value.

Group conclusion on para. 7.1.3. and 7.1.4.: amendments not needed, due to amendments in para. 7.1.1. → para 7.1.3. and 7.1.4. remain in their original version, no change!

Paragraph 7.1.3., amend to read:

- 7.1.3. The ALKS shall implement strategies to detect and compensate for environmental conditions that reduce the detection range ~~for modify the dynamic performance of the vehicle including its deceleration potential.~~ e.g. prevent enabling the system, disabling the system and transferring the control back to the driver, reducing the speed when visibility is too low. These strategies shall be described by the manufacturer and assessed according to Annex 4.

Paragraph 7.1.4., amend to read:

- 7.1.4. The vehicle manufacturer shall provide evidence that the effects of wear and ageing do not reduce the performance of the sensing system below the minimum required value specified in paragraph 7.1. over the lifetime of the system/vehicle ~~nor degrade the dynamic performances of the vehicle including its deceleration potential inconsistently with the performance of the sensing system.~~

Group conclusion: Decision to include modifications to Annex 3 with some further amendments from JP proposal (UNR157-08-06) and OICA/CLEPA proposal (UNR157-08-12) as outlined below.

Annex 3, amend to read:

1. General

1. This document clarifies derivation process to define conditions under which ~~Automated Lane Keeping Systems (the ALKS)~~ **vehicle** shall avoid a collision. Conditions under which ALKS shall avoid a collision are determined by a ~~general simulation program with following attentive human driver~~ **two possible** performance models and⁺ related parameters in the traffic critical disturbance scenarios.

2. Traffic critical scenarios

- 2.1. Traffic disturbance critical scenarios are those which have conditions under which **the ALKS vehicle** may not be able to avoid a collision.
- 2.2. Following three are traffic critical scenario:
- (a) Cut-in: the ‘other vehicle’ suddenly merges in front of the ‘ego-~~ALKS vehicle~~’
 - (b) Cut-out: the ‘other vehicle’ suddenly exits the lane of the **ALKS vehicle** ‘ego-vehicle’
 - (c) Deceleration: the ‘other vehicle’ suddenly decelerates in front of the **ALKS vehicle** ‘ego-vehicle’
- 2.3. Each of these traffic critical scenarios can be created using the following parameters/elements:
- (a) Road geometry
 - (b) Other vehicles’ behavior/maneuver

3. Performance models of ALKS

Group conclusion: amendments proposed by JP (UNR157-08-06) and OICA/CELP (UNR146-08-12) agreed.

- 3.1. Traffic critical scenarios of ALKS are divided into preventable and unpreventable scenarios. The threshold for preventable/unpreventable is based on the simulated performance of a ~~skilled~~ **careful competent** and ~~competent~~ **careful attentive** human driver. It is expected that some of the "unpreventable" scenarios by human standards may actually be preventable by the ALKS system.
- 3.2. **For the purpose of determining whether a traffic critical scenario is preventable or unpreventable, guidance can be taken from the following two performance models below can be used.**
- 3.3 **"Performance model 1"**
- 3.3.1. **In the first performance model**, the avoidance capability of the driver model is assumed to be only by braking. The driver model is separated into the following three segments: "Perception"; "Decision"; and, "Reaction". ~~The following~~ **in Figure 1** is a visual representation of these segments.:-
- 3.3.1.1. To determine conditions under which Automated Lane Keeping Systems (ALKS) shall avoid a collision, performance model factors for these three segments in ~~the following Table 1 table~~ **Table 1** should be used as the performance model of ALKS considering attentive human drivers' behavior with ADAS.

Figure 1

Group conclusion: agreed to amend title of figure accordingly:

~~Skilled Careful~~ **Careful Competent** and ~~competent careful~~ **human performance model**

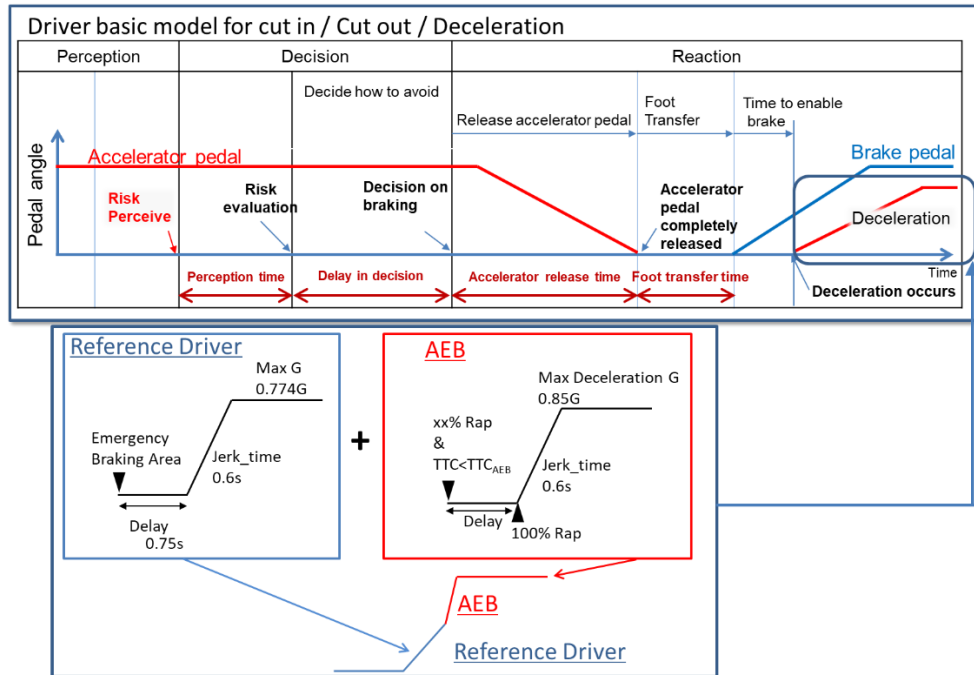

Group conclusion: agreed amendments.

Table 1

Performance model factors for vehicles

		Factors
Risk perception point	Lane change (cutting in, cutting out)	Deviation of the center of a vehicle over 0.375m from the center of the driving lane (derived from research by Japan)
	Deceleration	Deceleration ratio of preceding vehicle and following distance of ego vehicle
Risk evaluation time		0.4 seconds (from research by Japan)
Time duration from having finished perception until starting deceleration		0.75 seconds (common data in Japan)
Jerking time to full deceleration (road friction 1.0)		0.6 seconds to 0.774G (from experiments by NHTSA and Japan)
Jerking time to full deceleration (after full wrap of ego vehicle and cut-in vehicle, road friction 1.0)		0.6 seconds to 0.85G (derived from UN Regulation No. 152 on AEBs)

3.3.2. Driver model for the three ALKS scenarios:

Group conclusion: agreed amendments for para. 3.3.2.1.

3.3.2.1. For Cut in scenario:

The lateral wandering distance the vehicle will normally wander within the lane is 0.375m.

The perceived boundary for cut-in occurs when the vehicle exceeds the normal lateral wandering distance (possibly prior to actual lane change)

The distance a. is the perception distance based on the perception time [a]. It defines the lateral distance required to perceive that a vehicle is executing a cut-in manoeuvre a. is obtained from the following formula;

$$a. = \text{lateral movement speed} \times \text{Risk perception time [a]} (0.4\text{sec})$$

The risk perception time begins when the leading vehicle exceeds the cut-in boundary threshold.

~~Max lateral movement speed is real world data in Japan.~~

~~Risk perception time [a] is driving simulator data in Japan.~~

2sec* is specified as the maximum Time To Collision (TTC) below which it was concluded that there is a danger of collision in the longitudinal direction.

~~Note: TTC = 2.0sec is chosen based on the UN Regulation guidelines on warning signals.~~

Figure 2
Driver model for the cut-in scenario

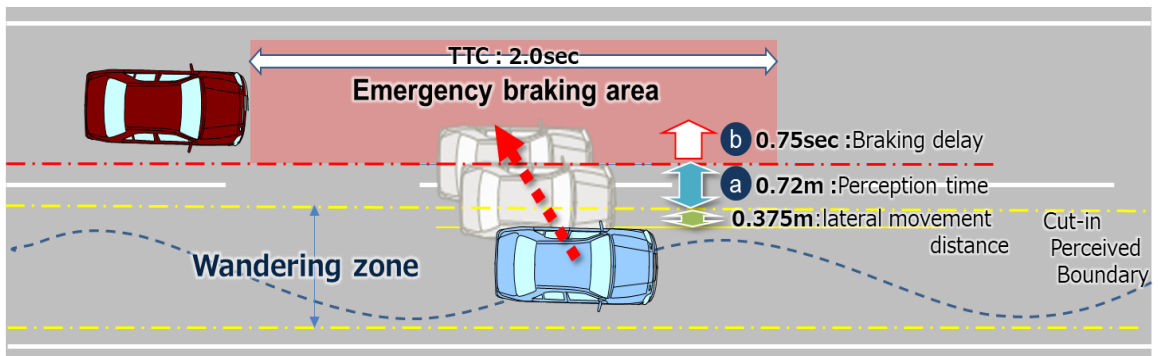

3.3.2.2. For Cut out scenario:

The lateral wandering distance the vehicle will normally wander within the lane is 0.375m.

The perceived boundary for cut-out occurs when the vehicle exceeds the normal lateral wandering distance (possibly prior to actual lane change)

The risk perception time [a] is 0.4 seconds #and begins when the leading vehicle exceeds the cut-out boundary threshold.

The time 2 sec is specified as the maximum Time Head Way (THW) for which it was concluded that there is a danger in longitudinal direction.

~~Note: THW = 2.0sec is chosen according to other countries' regulations and guidelines.~~

Figure 3
Cut in scenario

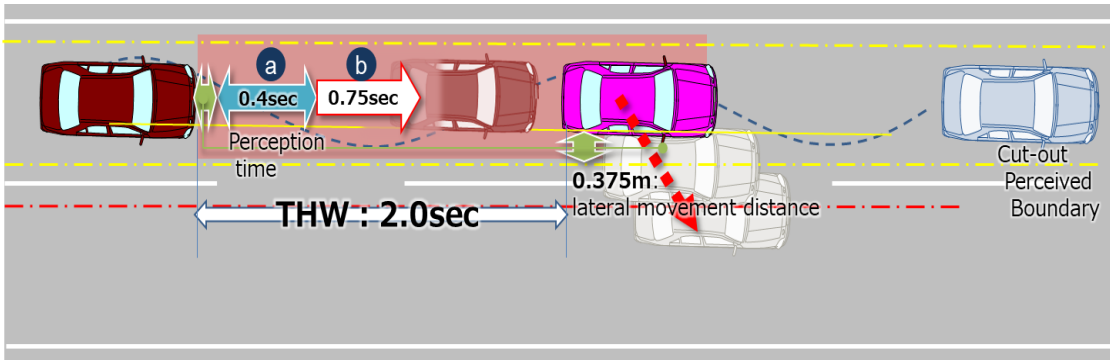

3.3.2.3. For Deceleration scenario:

The risk perception time [a] is 0.4 seconds. The risk perception time [a] begins when the leading vehicle exceeds a deceleration threshold 5m/s^2 .

Figure 4
Deceleration scenario

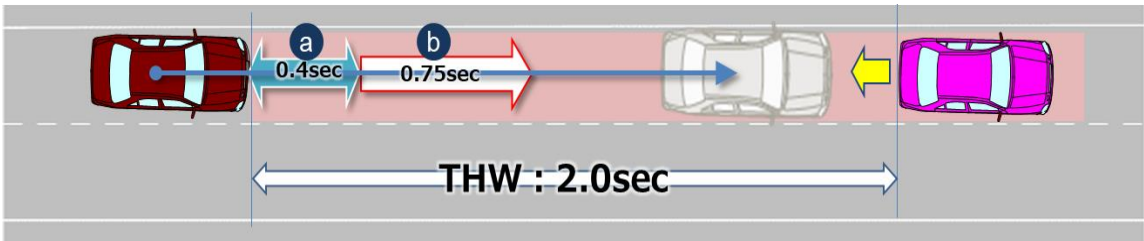

4. Parameters

3.3.3. Parameters

3.3.3.1. Parameters below are essential when describing the pattern of the traffic critical scenarios in section 2.1.

3.3.3.2. Additional parameters could be added according to the operating environment (e.g. friction rate of the road, road curvature, lighting conditions).

Table 2
Additional parameters

Operating conditions	Roadway	<p>Number of lanes = The number of parallel and adjacent lanes in the same direction of travel</p> <p>Lane Width = The width of each lane</p> <p>Roadway grade = The grade of the roadway in the area of test</p> <p>Roadway condition = the condition of the roadway (dry, wet, icy, snow, new, worn) including coefficient of friction</p> <p>Lane markings = the type, colour, width, visibility of lane markings</p>
	Environmental conditions	<p>Lighting conditions = The amount of light and direction (i.e., day, night, sunny, cloudy)</p>

		Weather conditions = The amount, type and intensity of wind, rain, snow etc.
Initial condition	Initial velocity	Ve0 = Ego vehicle
		Vo0 = Leading vehicle in lane or in adjacent lane
		Vf0 = Vehicle in front of leading vehicle in lane
	Initial distance	dx0 = Distance in Longitudinal direction between the front end of the ego vehicle and the rear end of the leading vehicle in ego vehicle's lane or in adjacent lane
		dy0 = Inside Lateral distance between outside edge line of ego vehicle in parallel to the vehicle's median longitudinal plane within lanes and outside edge line of leading vehicle in parallel to the vehicle's median longitudinal plane in adjacent lines.
		dy0_f = Inside Lateral distance between outside edge line of leading vehicle in parallel to the vehicle's median longitudinal plane within lanes and outside edge line of vehicle in front of the leading vehicle in parallel to the vehicle's median longitudinal plane in adjacent lines.
		dx0_f = Distance in longitudinal direction between front end of leading vehicle and rear end of vehicle in front of leading vehicle
		dfy = Width of vehicle in front of leading vehicle
		doy = Width of leading vehicle
		dox = Length of the leading vehicle
Vehicle motion	Lateral motion	Vy =Leading vehicle lateral velocity
	Deceleration	Gx_max = Maximum deceleration of the leading vehicle in G
		dG/dt = Deceleration rate (Jerk) of the leading vehicle

3.3.3.3. Following are visual representations of parameters for the three types of scenarios

Figure 5
Visualisation

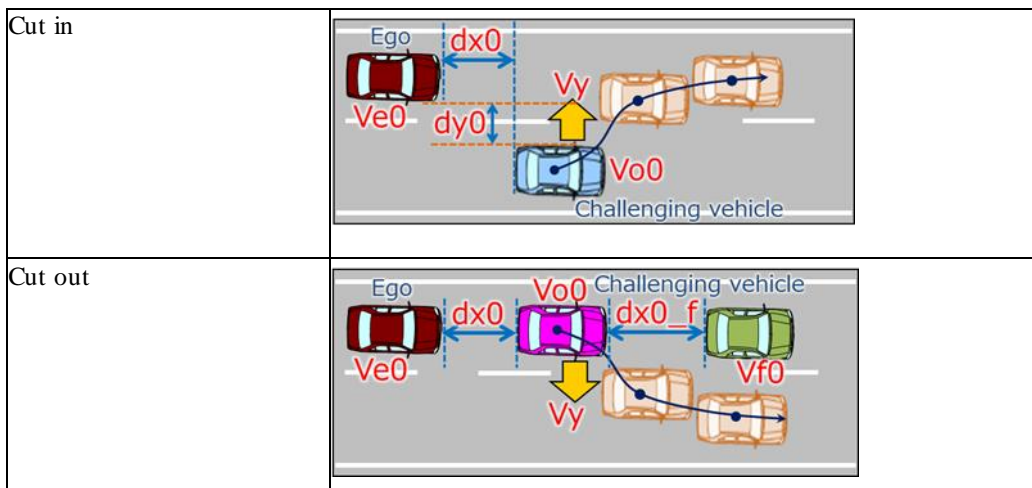

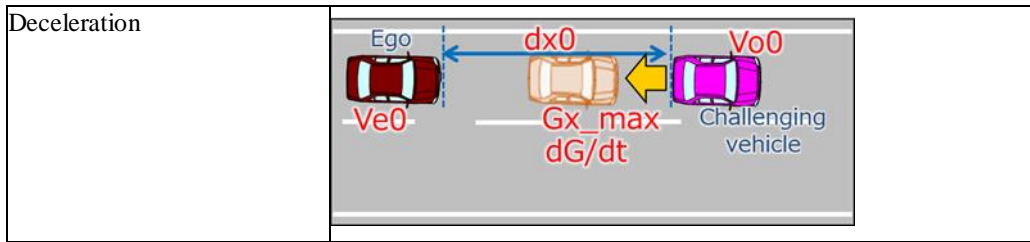

5. 3.3.4 Reference

Following data sheets are pictorial examples of simulations which determines conditions under which ALKS **travelling at a speed up to 60 km/h** shall avoid a collision, taking into account the combination of every parameter, *at and below* the maximum permitted ALKS vehicle speed.

5.1. 3.3.4.1. Cut in

Figure 6
Parameters

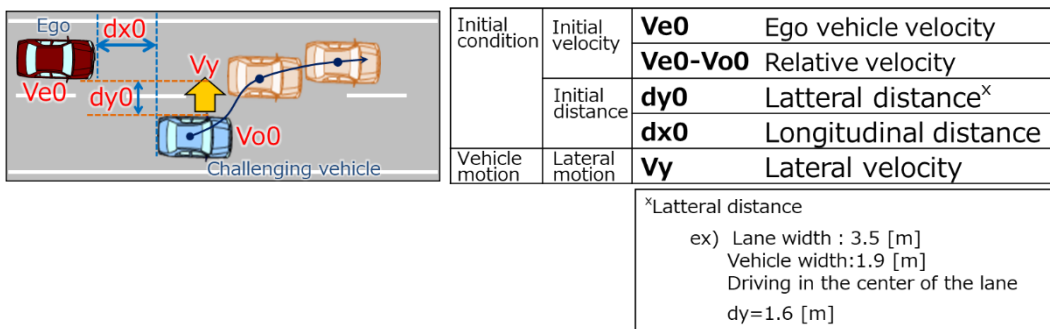

(Data sheets image)

Figure 7
Overview

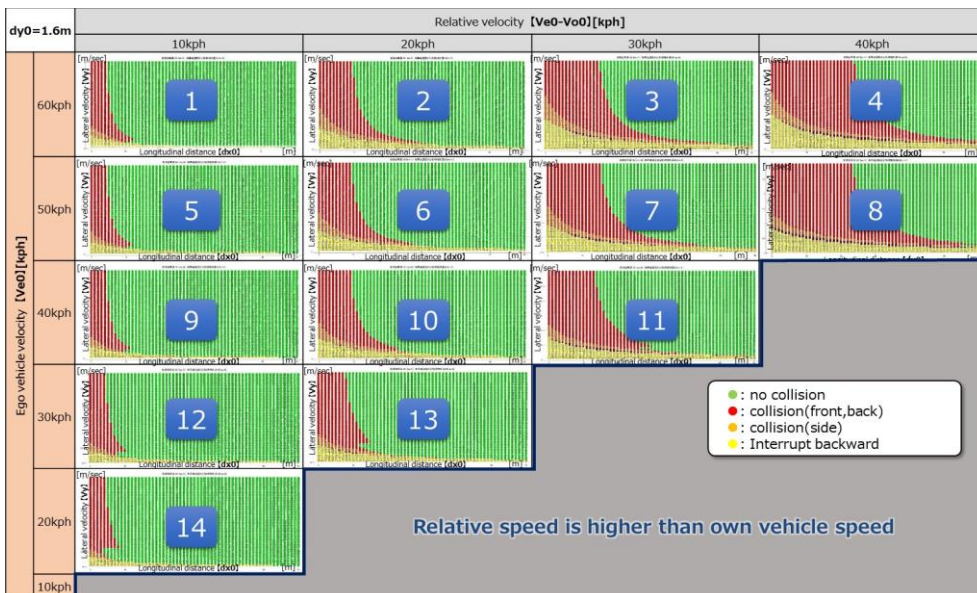
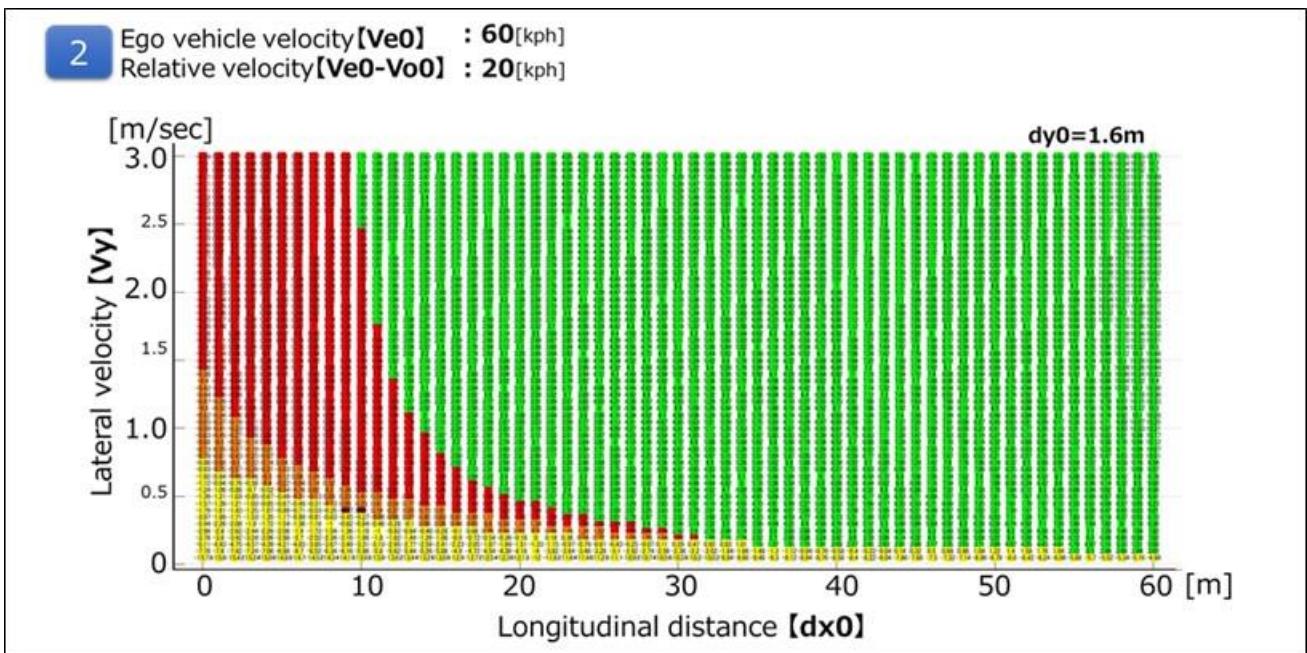
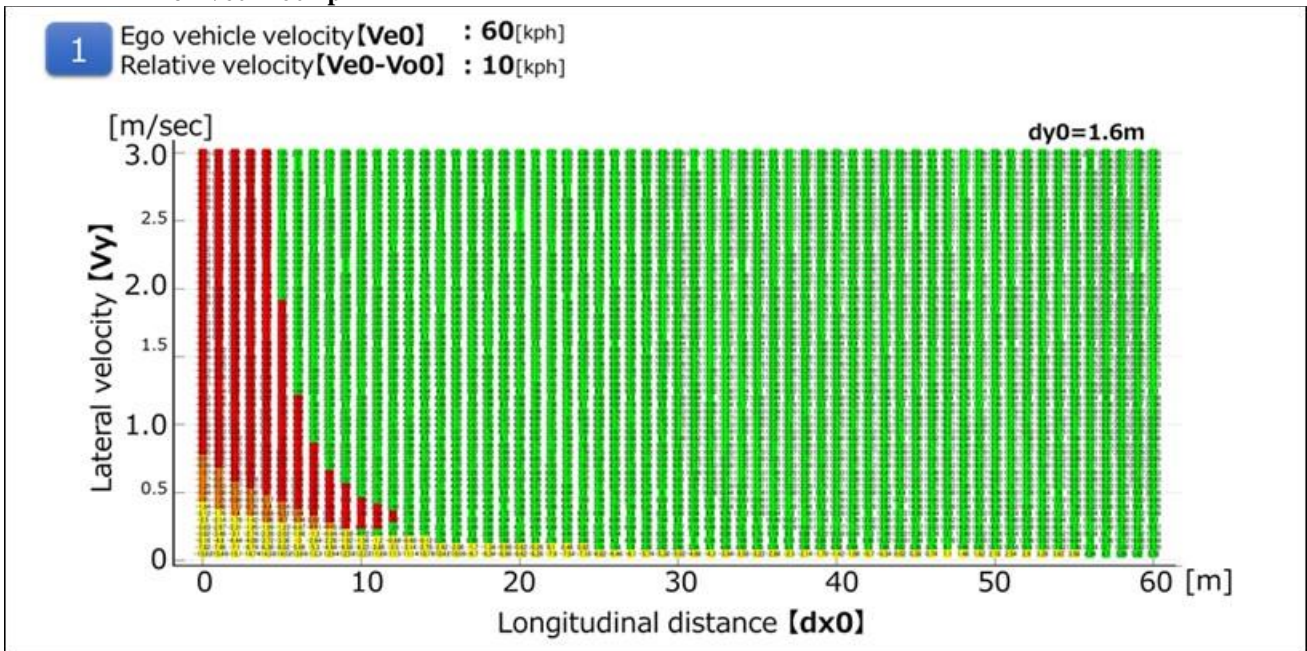
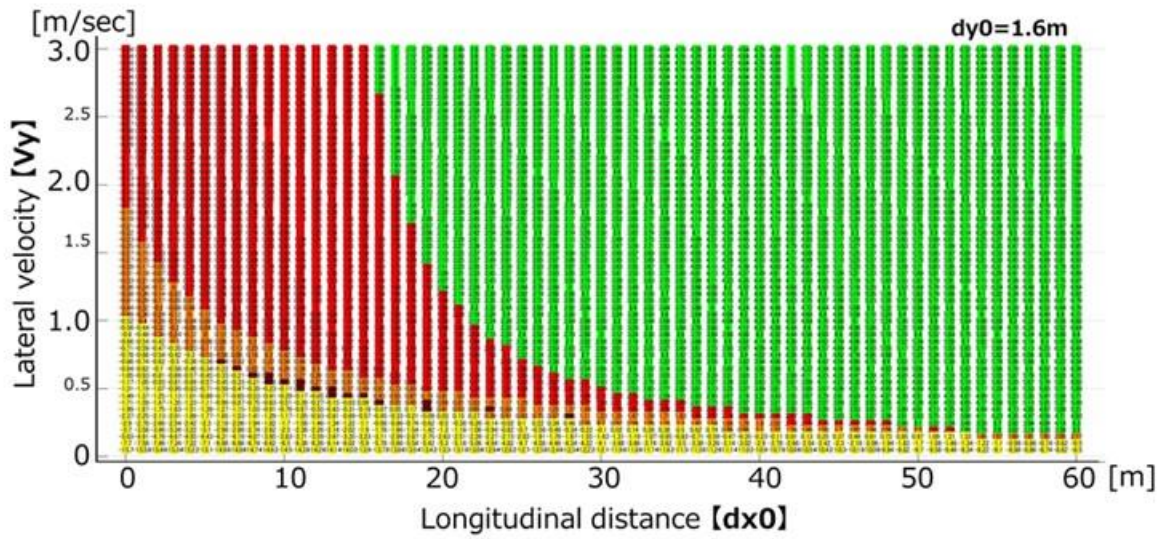

Figure 8

For $V_{e0} = 60$ kph



3 Ego vehicle velocity **[Ve0]** : 60[kph]
Relative velocity **[Ve0-Vo0]** : 30[kph]



4 Ego vehicle velocity **[Ve0]** : 60[kph]
Relative velocity **[Ve0-Vo0]** : 40[kph]

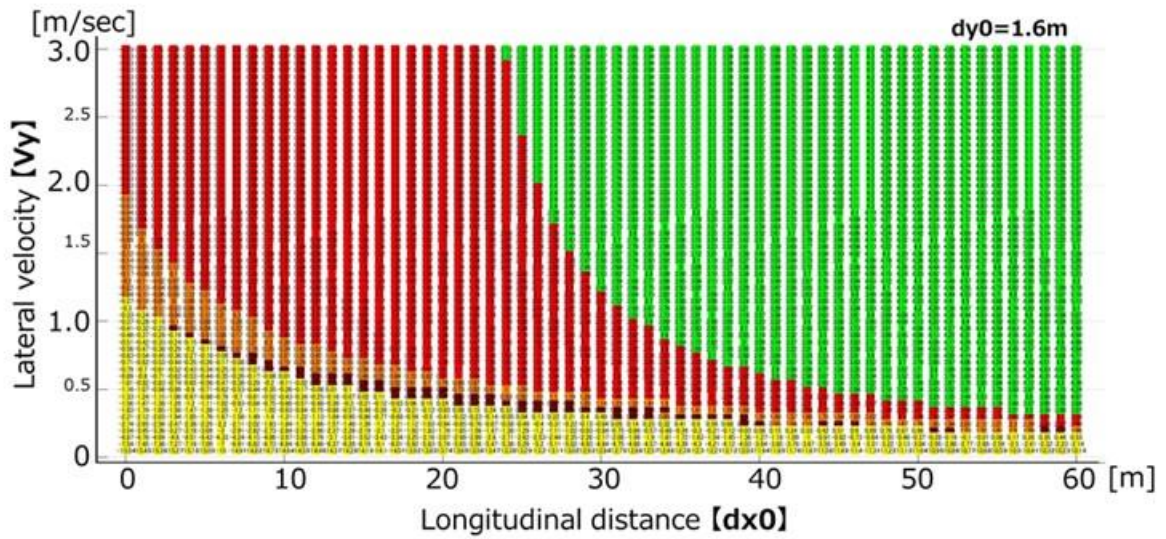
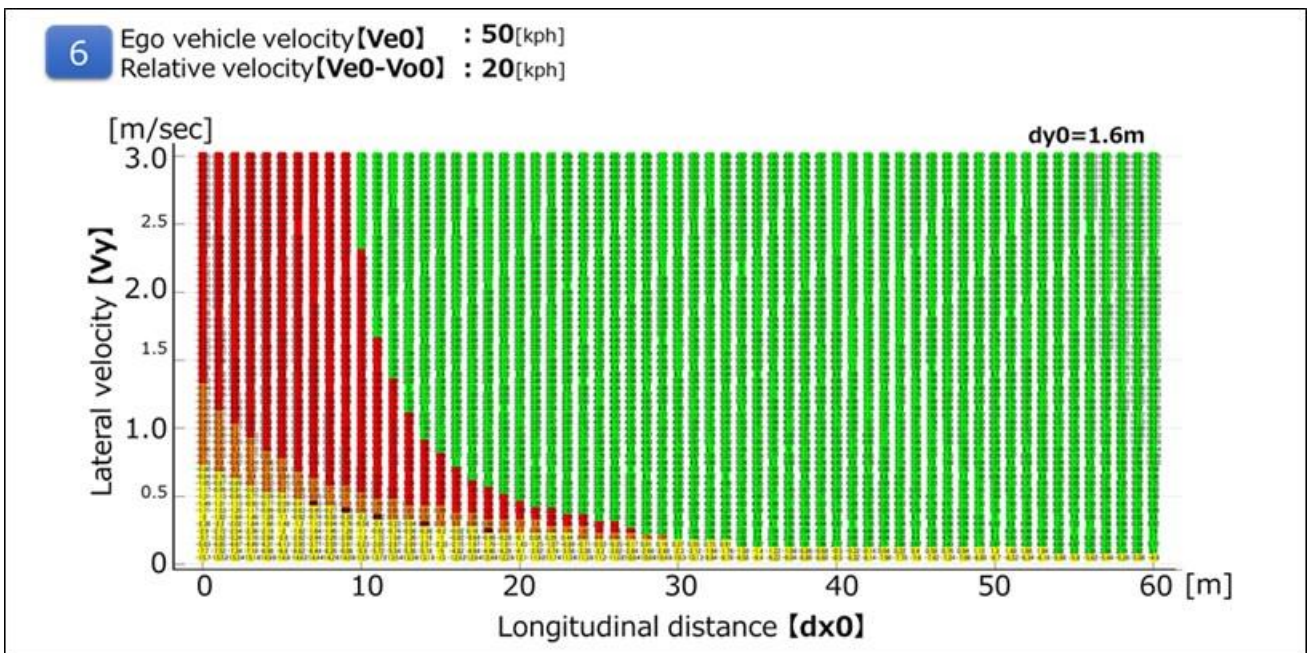
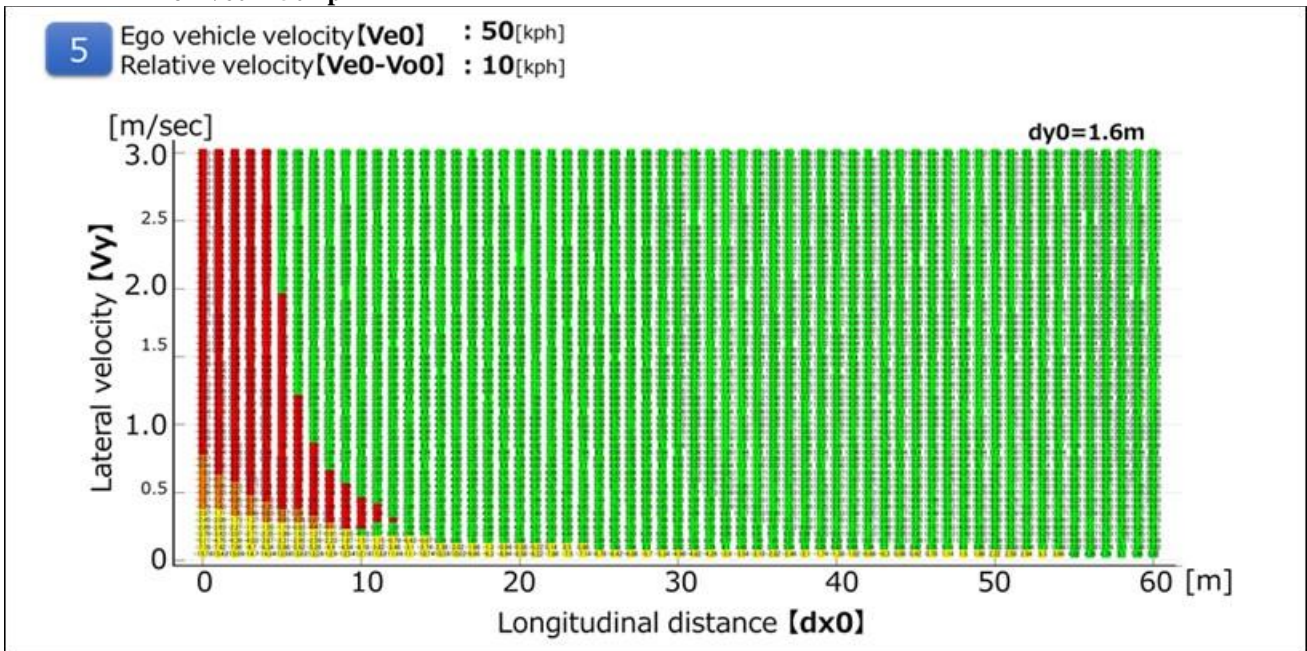
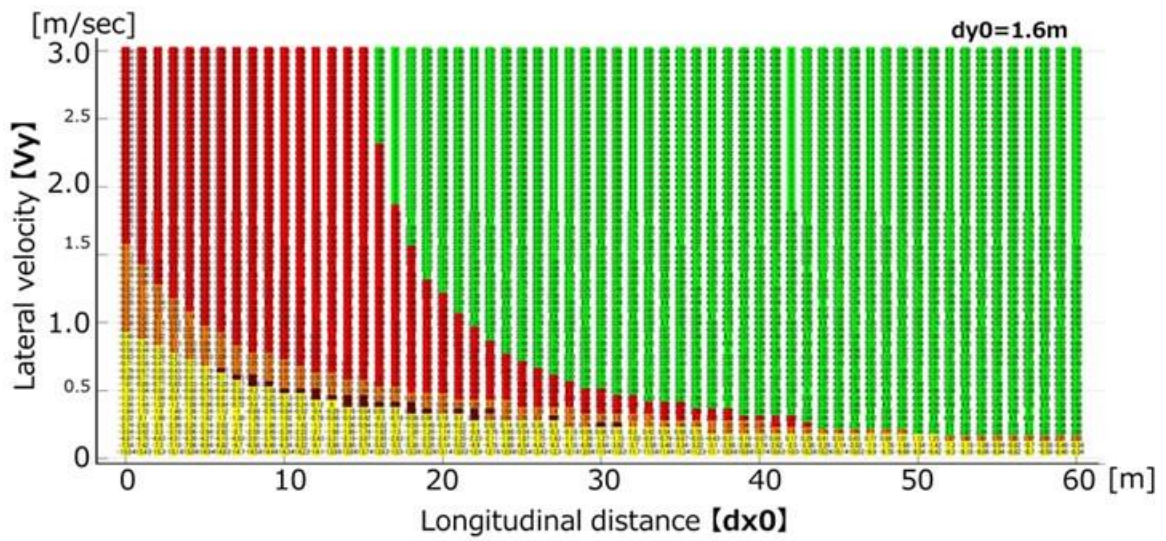

Figure 9

For $V_{e0} = 50$ kph



7 Ego vehicle velocity **[Ve0]** : 50[kph]
Relative velocity **[Ve0-Vo0]** : 30[kph]



8 Ego vehicle velocity **[Ve0]** : 50[kph]
Relative velocity **[Ve0-Vo0]** : 40[kph]

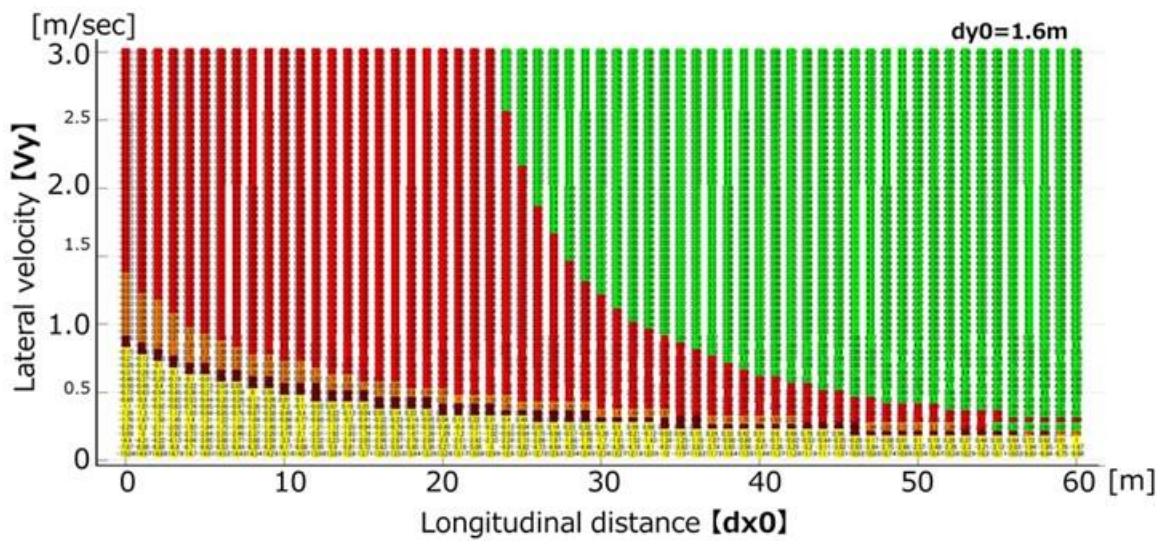
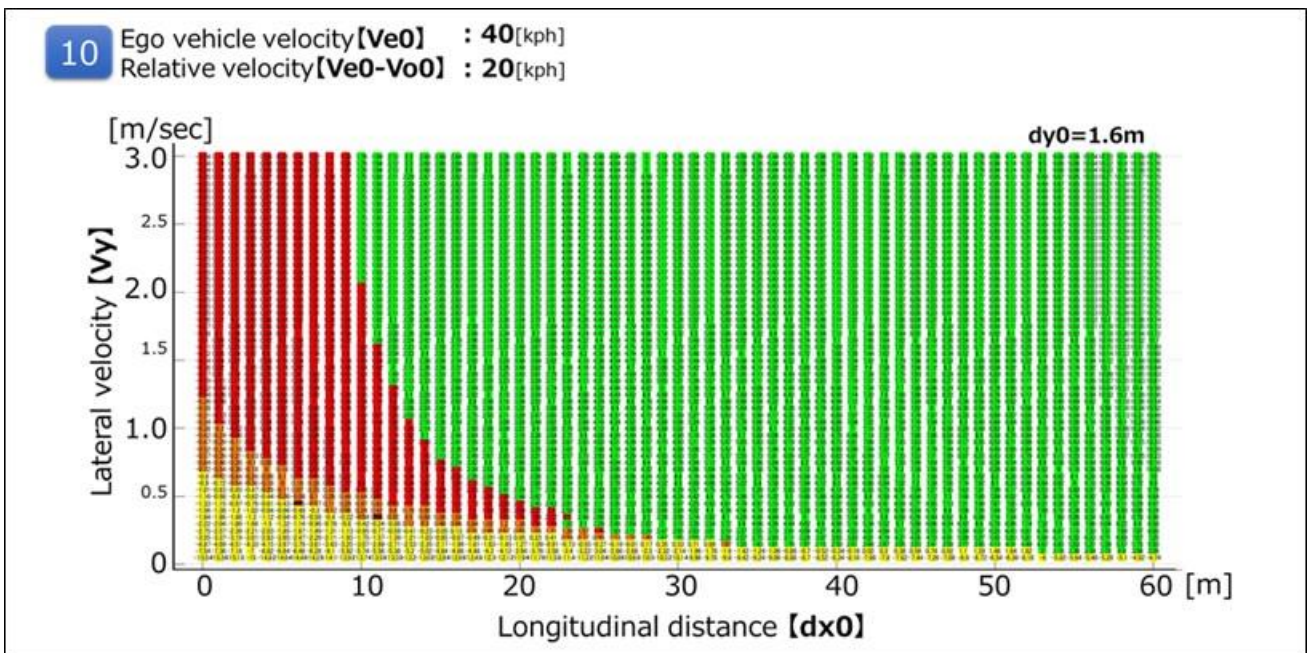
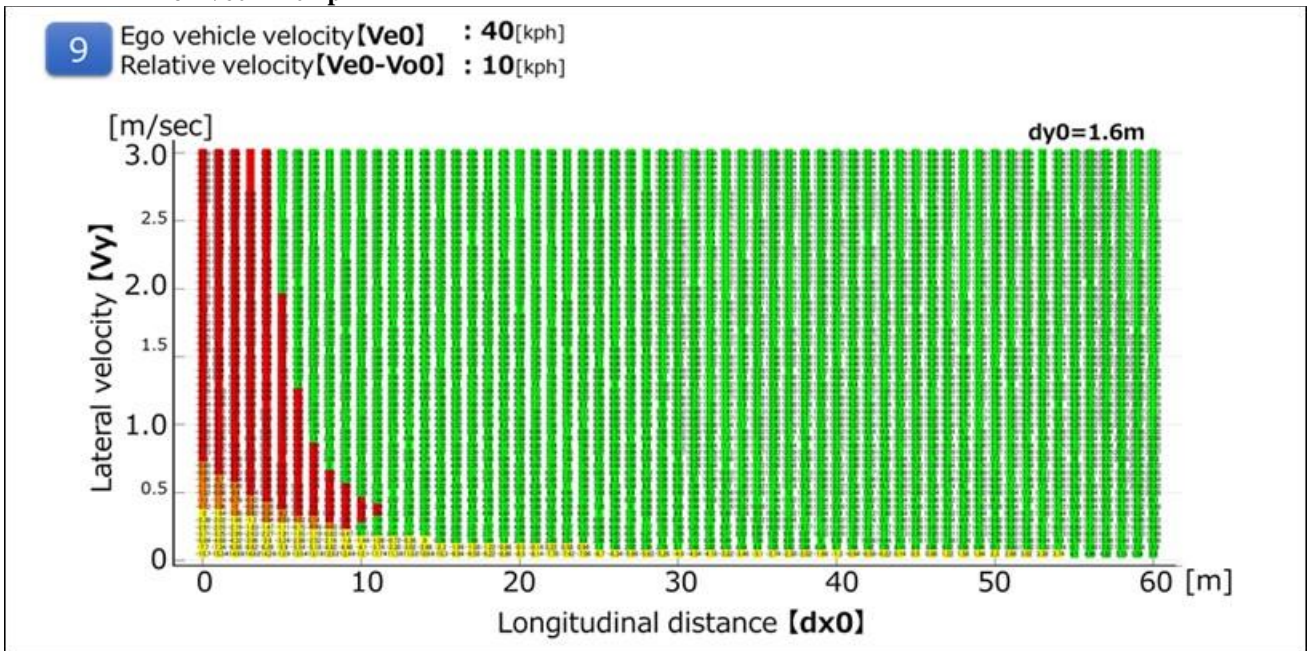

Figure 10
For $V_{e0} = 40$ kph



11 Ego vehicle velocity [Ve0] : 40[kph]
Relative velocity [Ve0-Vo0] : 30[kph]

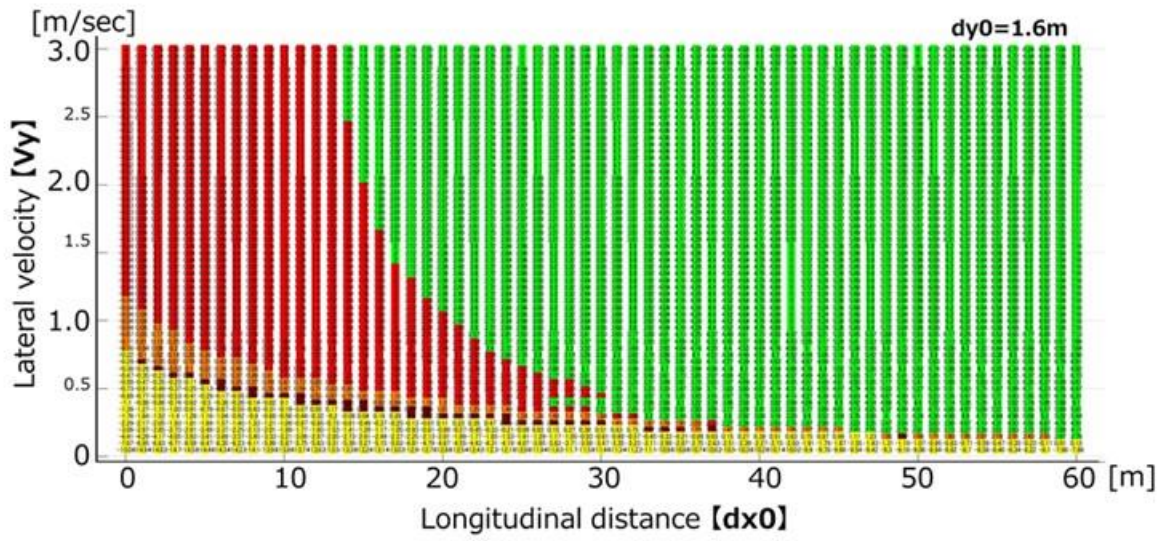
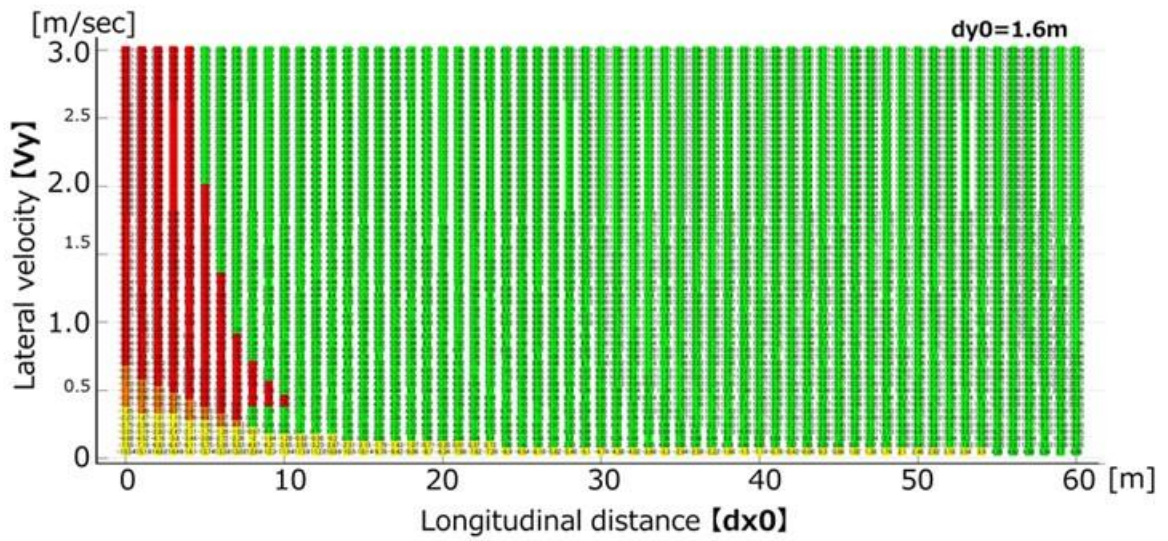

Figure 11
For $V_{e0} = 30$ kph

12 Ego vehicle velocity [Ve0] : 30[kph]
Relative velocity [Ve0-Vo0] : 10[kph]



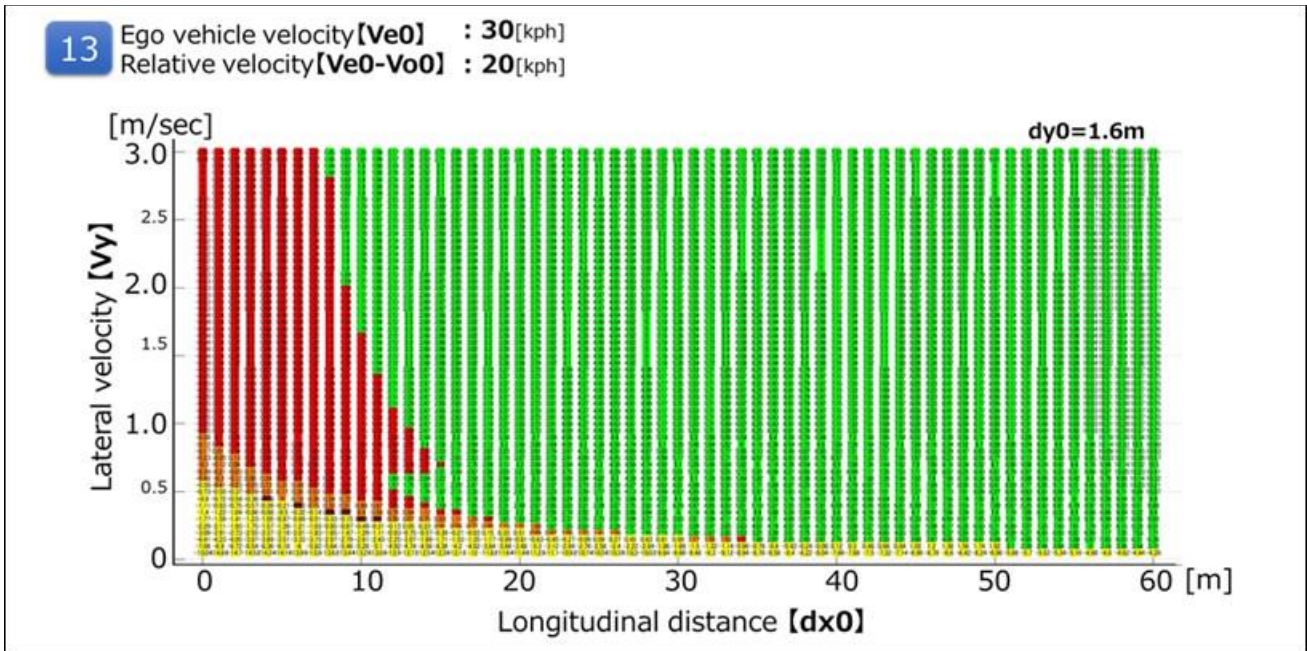
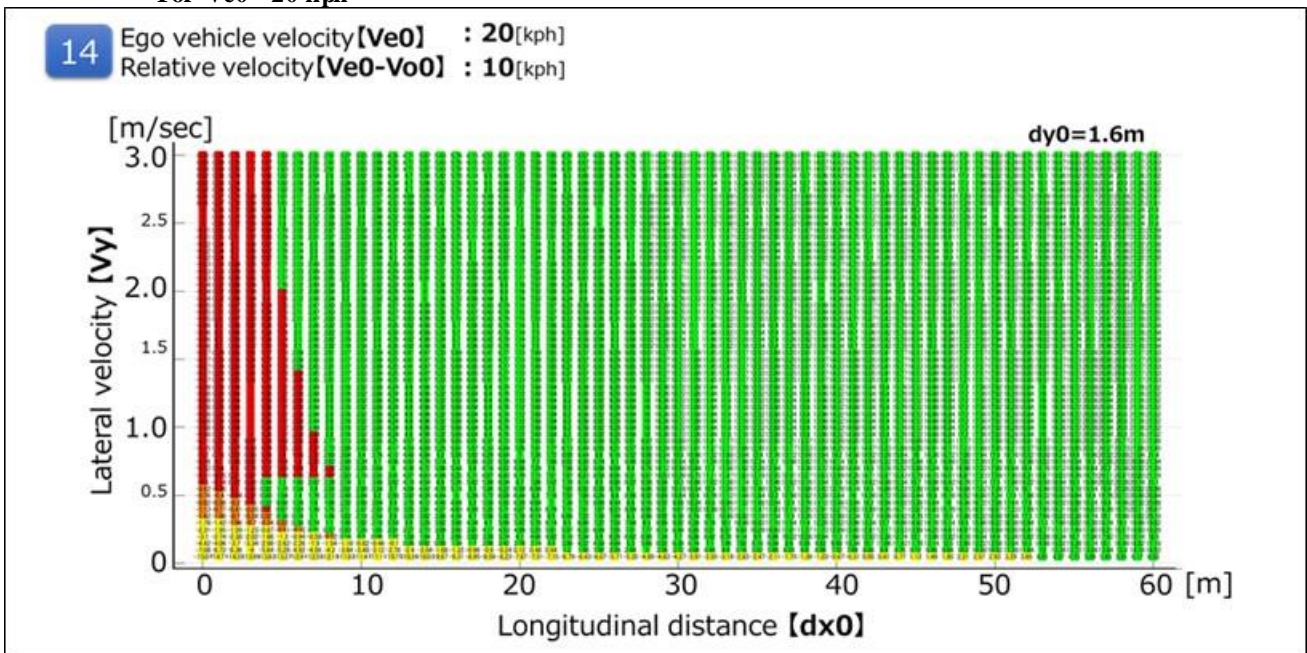

Figure 12
For $V_{e0} = 20$ kph



5.2. 3.3.4.2. Cut out

It is possible to avoid all the deceleration (stop) vehicles ahead of the preceding vehicle cut-out in the following running condition at THW 2.0 sec.

Figure 12
Parameters

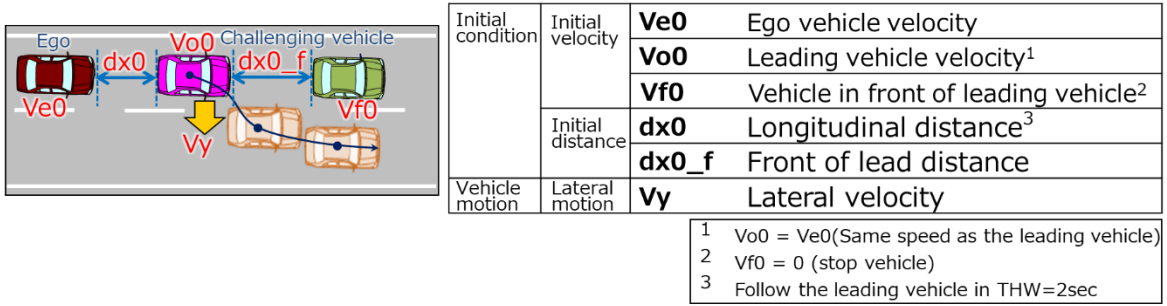

(Data sheets image)

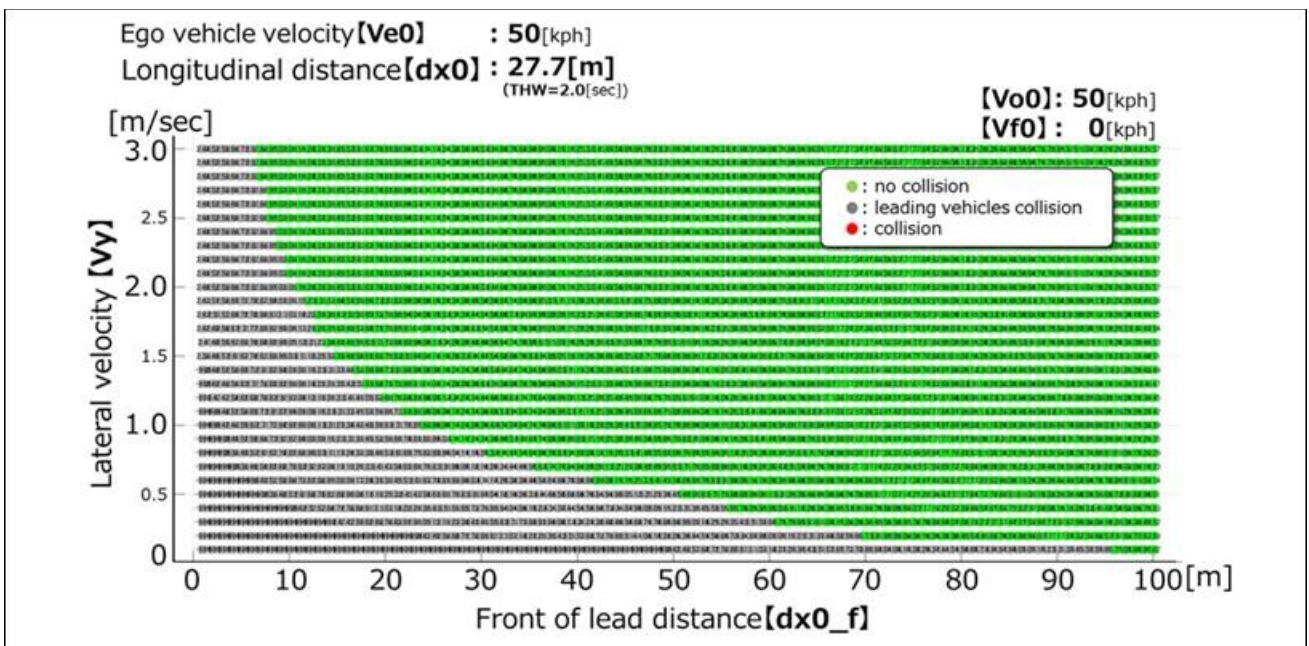
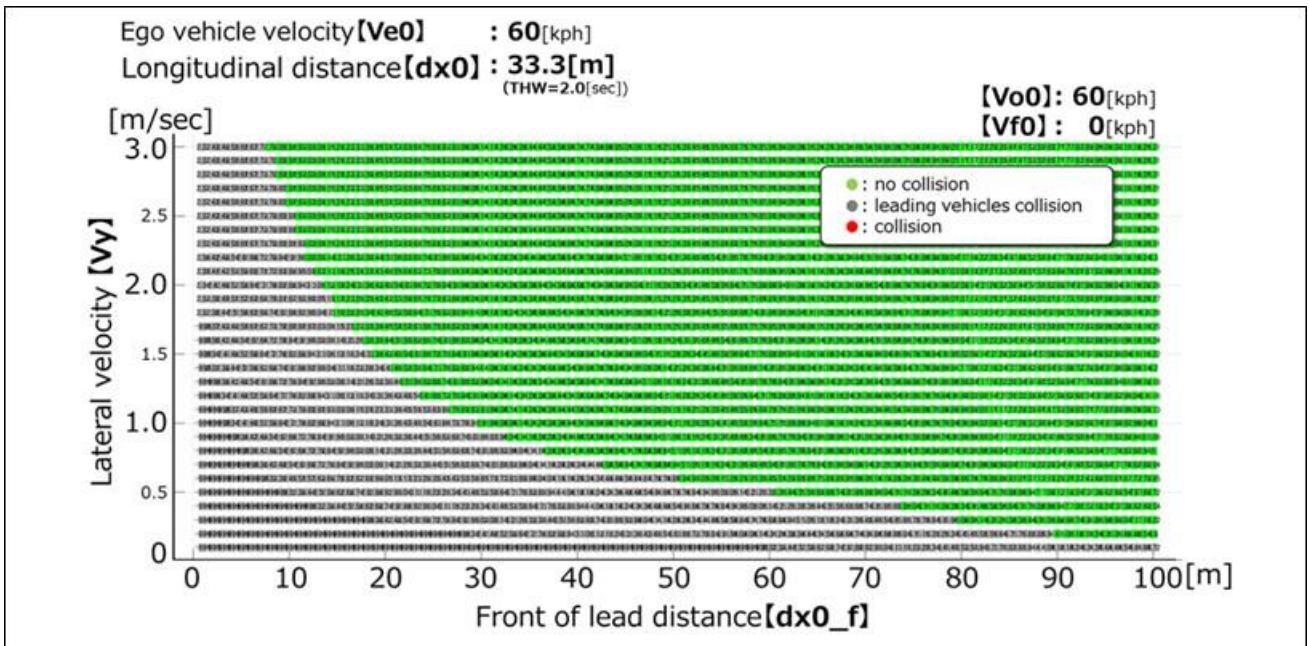

Ego vehicle velocity **[Ve0]** : 40[kph]
 Longitudinal distance **[dx0]** : 22.2[m]
 (THW=2.0[sec])

[Vo0]: 40[kph]
[Vf0]: 0[kph]

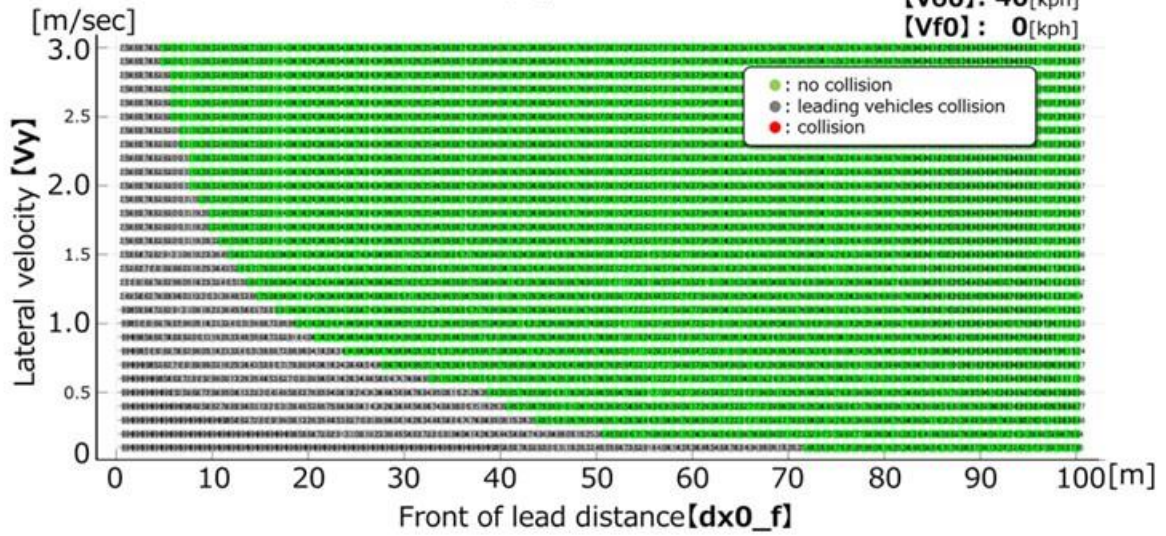

Ego vehicle velocity **[Ve0]** : 30[kph]
 Longitudinal distance **[dx0]** : 16.6[m]
 (THW=2.0[sec])

[Vo0]: 30[kph]
[Vf0]: 0[kph]

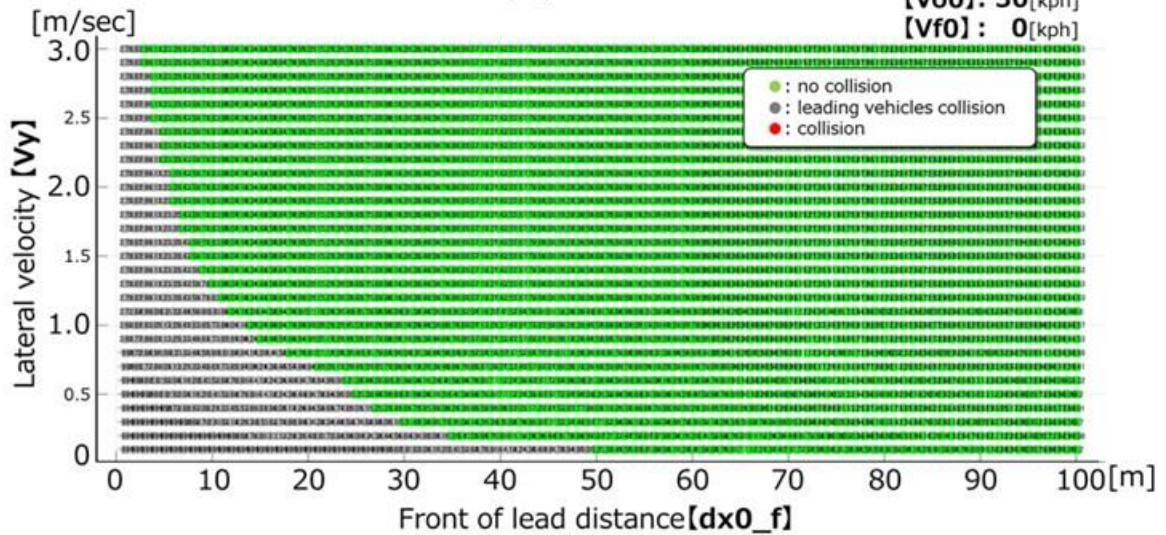

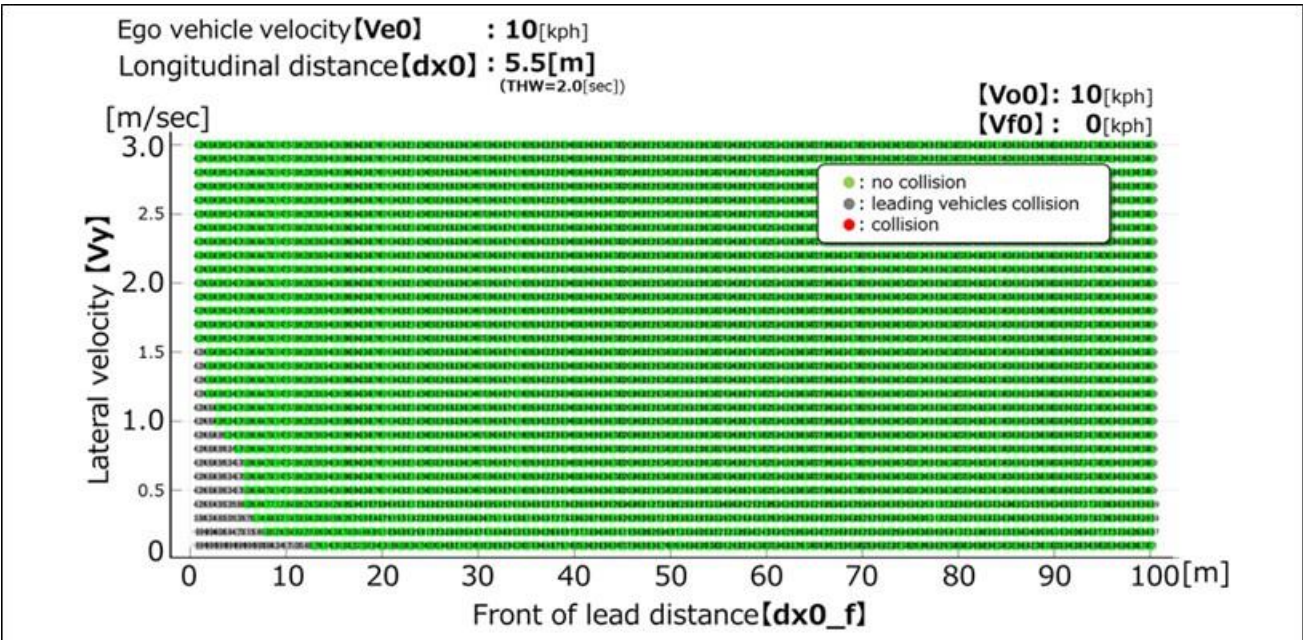
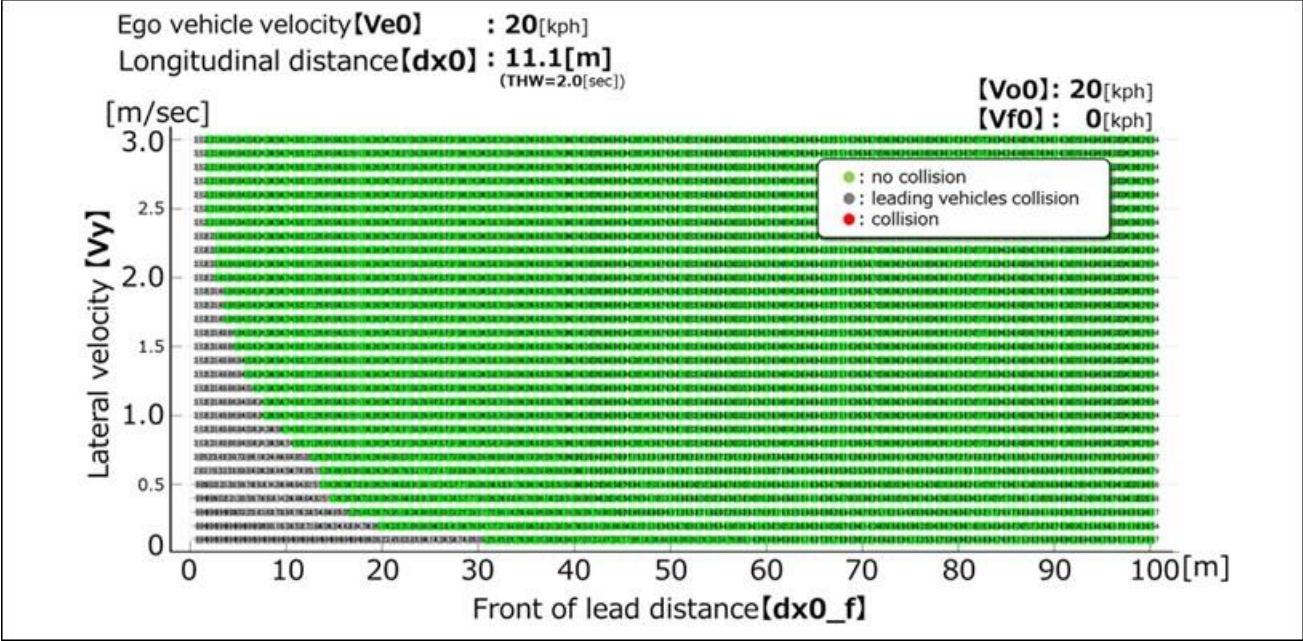

5.4- 3.3.4.3. Deceleration

It is possible to avoid sudden deceleration of -1.0G or less in the follow-up driving situation at THW 2.0sec.

(Data sheet image)

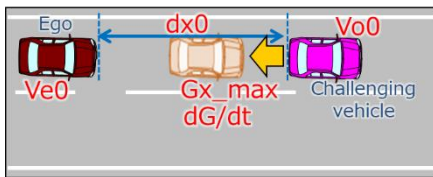

Initial condition	Initial velocity	Ve0	Ego vehicle velocity
		Vo0	Leading vehicle velocity ¹
Vehicle motion	Initial distance	dx0	Longitudinal distance ²
	Deceleration	Gx_max	Maximum deceleration G
		dG/dt	Deceleration rate ³

- 1 Vo0 = Ve0(Same speed as the leading vehicle)
0[km/h] for a stopped vehicle
- 2 Follow the leading vehicle in THW=2sec
- 3 The most severe conditions ∞

(Data sheets image)

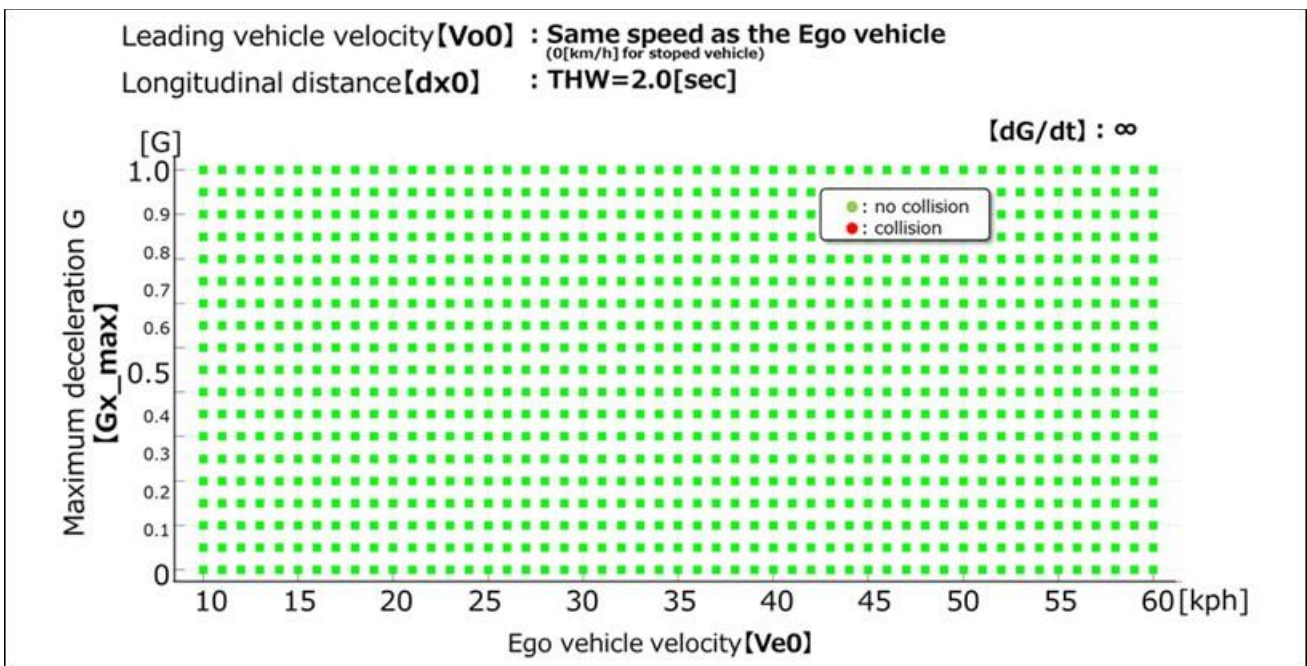

3.4 “Performance model 2”

Group conclusion: amendments proposed by JP (UNR157-08-06) and OICA/CELP (UNR146-08-12) agreed.

3.4.1. In the second performance model, it is assumed that the driver can anticipate the risk of a collision and apply proportionate braking. ~~apply proportionate braking actions in order to anticipate the risk of collision.~~ In this case, the performance model considers the following three actions performed by the competent and careful human driver: "Lateral Safety Check"; "Longitudinal Safety Check"; and, "Reaction". A Reaction is implemented only if the Lateral and Longitudinal Safety Checks identify a risk of imminent collision. The diagram reported in Figure 2 provides a visual representation of the decision flow followed by the driver in the second performance model for the case of the cut-in traffic critical scenario.

Figure 6
Flow-chart of the second ALKS performance model for the case of the cut in traffic critical scenario

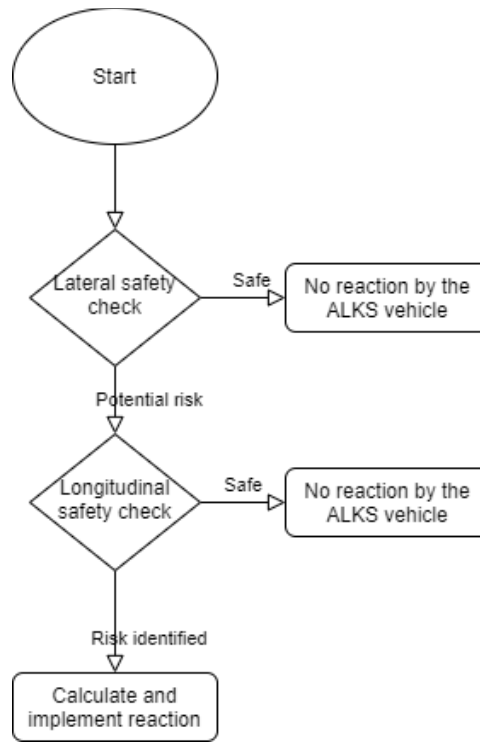

3.4.2. Cut-in traffic critical scenario.

3.4.2.1. The Lateral Safety Check identifies a potential risk of collision if the following conditions hold true:

- a) the rear of the ‘other vehicle’ is ahead of the front of the ALKS vehicle along the longitudinal direction of motion;
- b) the ‘other vehicle’ is moving towards the ALKS vehicle
- c) the longitudinal speed of the ALKS vehicle is greater than the longitudinal speed of the ‘other vehicle’
- d) the following equation is satisfied

$$\frac{dist_{lat}}{u_{cut-in,lat}} < \frac{dist_{lon} + length_{ego} + length_{cut-in}}{u_{ego,lon} - u_{cut-in,lon}} + 0.1$$

Where

- $dist_{lat}$ instantaneous lateral distance between the two vehicles
- $dist_{lon}$ instantaneous longitudinal distance between the two vehicles
- $length_{ego}$ length of the ALKS vehicle
- $length_{cut-in}$ length of the ‘other vehicle’
- $u_{cut-in,lat}$ instantaneous lateral speed of the ‘other vehicle’
- $u_{ego,lon}$ instantaneous longitudinal speed of the ALKS vehicle
- $u_{cut-in,lon}$ instantaneous longitudinal speed of the ‘other’ vehicle.

3.4.2.2. The Longitudinal Safety Check requires the assessment of two Fuzzy Surrogate Safety Metrics, the Proactive Fuzzy Surrogate Safety Metric (PFS), and the Critical Fuzzy Surrogate Safety Metric (CFS).

Correction of the equation by JRC/EC (05.10.2021):

3.4.2.2.1. The PFS is defined by the following equation:

$$PFS(dist_{lon}) = \begin{cases} 1 & \text{if } 0 < dist_{lon} - d_1 < d_{unsafe} \\ 0 & \text{if } dist_{lon} - d_1 > d_{safe} \\ \frac{dist_{lon} - d_{safe} - d_1}{d_{unsafe} - d_{safe}} & \text{if } d_{unsafe} < dist_{lon} - d_1 < d_{safe} \end{cases}$$

where

d_1 is the safety distance when the two vehicles reach complete stop

$$d_{safe} = u_{ego,lon} \tau + \frac{u_{ego,lon}^2}{2b_{ego,comf}} - \frac{u_{cut-in,lon}^2}{2b_{ego,max}} + d_1$$

$$d_{unsafe} = u_{ego,lon} \tau + \frac{u_{ego,lon}^2}{2b_{ego,max}} - \frac{u_{cut-in,lon}^2}{2b_{cut-in,max}}$$

with

τ the reaction time of the ALKS vehicle defined as the total time from the moment in which the need for a reaction is identified until it starts to be implemented

$b_{ego,comf}$ the comfortable deceleration of the ALKS vehicle

$b_{ego,max}$ the maximum deceleration of the ALKS vehicle

$b_{cut-in,max}$ the maximum deceleration of the 'other vehicle'

3.4.2.2.2. The CFS is defined by the following equation:

$$CFS(dist_{lon}) = \begin{cases} 1 & \text{if } 0 < dist_{lon} < d_{unsafe} \\ 0 & \text{if } dist_{lon} \geq d_{safe} \\ \frac{dist_{lon} - d_{safe}}{d_{unsafe} - d_{safe}} & \text{if } d_{unsafe} \leq dist_{lon} < d_{safe} \end{cases}$$

Where

$$d_{safe} = \begin{cases} \frac{(u_{ego,lon} - u_{cut-in,lon})^2}{2a'_{ego}} & \text{if } u_{ego,lon,NEXT} \leq u_{cut-in,lon} \\ d_{new} + \frac{(u_{ego,lon,NEXT} - u_{cut-in,lon})^2}{2b_{ego,comf}} & \text{if } u_{ego,lon,NEXT} > u_{cut-in,lon} \end{cases}$$

$$d_{unsafe} = \begin{cases} \frac{(u_{ego,lon} - u_{cut-in,lon})^2}{2a'_{ego}} & \text{if } u_{ego,lon,NEXT} \leq u_{cut-in,lon} \\ d_{new} + \frac{(u_{ego,lon,NEXT} - u_{cut-in,lon})^2}{2b_{ego,max}} & \text{if } u_{ego,lon,NEXT} > u_{cut-in,lon} \end{cases}$$

in which

$$a'_{ego} = \max(a_{ego}, -b_{ego,comf})$$

$$u_{ego,lon,NEXT} = u_{ego,lon} + a'_{ego} \tau$$

$$d_{new} = \left(\frac{(u_{ego,lon} + u_{ego,lon,NEXT})}{2} - u_{cut-in,lon} \right) \tau$$

where

a_{ego} the instantaneous longitudinal acceleration of the ALKS vehicle

a'_{ego}	a modified instantaneous acceleration which assume that ALKS vehicle cannot decelerate by more than $b_{ego,comf}$
$u_{ego,lon,NEXT}$	the expected longitudinal speed of the ALKS vehicle after the reaction time assuming constant acceleration
d_{new}	the expected longitudinal change in distance between the ALKS vehicle and the 'other vehicle' after the reaction time

3.4.2.2.3. The Longitudinal Safety Check identifies a potential risk if either PFS or CFS are greater than 0.

3.4.2.3. If a risk is identified the ALKS vehicle is assumed to plan and implement a reaction by decelerating according to the following equation:

$$b_{reaction} = \begin{cases} CFS \cdot (b_{ego,max} - b_{ego,comf}) + b_{ego,comf} & \text{if } CFS > 0 \\ PFS \cdot b_{ego,comf} & \text{if } CFS = 0 \end{cases}$$

3.4.2.3.1 The deceleration is implemented after a time equal to τ when it starts to increase with a constant rate equal to the maximum jerk.

3.4.2.4. In the case the reaction is not able to prevent the vehicle to collide with the cutting-in vehicle, the scenario is classified as unpreventable, otherwise it is classified as preventable.

3.4.3. Cut-out traffic critical scenario.

In case of a cut-out, the model follows the same flow chart described in 3.2.2.1. for the cut-in scenario, with three changes:

- The Lateral Safety check is ignored, as the ALKS vehicle and the static object are already in the same lane.
- The Longitudinal Safety check is evaluated as in paragraph 3.2.2.1.2. with the state parameters being calculated for the static object instead of the cutting in vehicle.
- The ALKS vehicle is assumed not to be able to start the reaction time before the cutting out vehicle's centre is outside the wandering zone of 0.375 m from the centre of the lane.

3.4.4. Deceleration traffic critical scenario

In case of a sudden deceleration of the preceding vehicle, the model follows the same flow chart described in 3.2.2.1. for the cut-in scenario, with two changes:

- The Lateral Safety check is ignored, as the ALKS vehicle and the preceding vehicle are already in the same lane.
- The Longitudinal Safety check is evaluated as in 3.2.2.1.2. with the state parameters being calculated for the preceding vehicle instead of the cutting in vehicle.

Group conclusion: amendments proposed by OICA/CELP (UNR146-08-12) agreed and work with UNECE secretariat to see in link can be provided in footnote

3.4.5. A software implementation of the second performance model to derive the scenario classification from simulation applied to the three traffic critical scenarios described in paragraph 2.2. of the present appendix is openly available. ~~at the following url: [link to be provided as soon as the software is published]. For any request of support to its use the following email address can be used: JRC-SMART-MOBILITY@ec.europa.eu~~

3.4.6. To determine conditions under which the ALKS vehicle shall avoid a collision, the following performance model factors shall be used.

Table 3
Performance model factors for vehicles

	<i>Factor</i>
Risk perception point	The time when either PFS or CFS value is not any longer 0
	In the case of cut-out the ALKS vehicle reaction time cannot start before the cutting out vehicle's centre is outside the wandering zone of 0.375 m from the centre of the lane
Reaction time of the ALKS vehicle	$\tau = 0.75$ seconds
Jerking (road friction 1.0)	12.65 m/s ³
Safety distance when the two vehicles reach complete stop	$d_1 = 2$ meters
Comfortable deceleration of the ALKS vehicle	$b_{ego,comf} = 4$ m/s ²
Maximum deceleration of the ALKS vehicle	$b_{ego,max} = 6$ m/s ²
Maximum deceleration of the 'other vehicle'	$b_{cut-in,max} = 7$ m/s ²

Come back: Consider JP's proposal (UNR157-08-06) to add/link MRMLC-relevant paragraphs (para. 4.6.1.to 4.6.4. and 4.6.7) with speed increase testing.

Points of discussion for Annex 5: Group agreement needed how to deal with the following two new on-road tests proposed by JRC/EC (UNR157-03-06). Can the 3 tests be added to UN-R 157? → Latest relevant proposals by JRC: document UNR157-07-07 (annex 5) and UNR157-07-08 (annex 6). Will be discussed in side meeting hosted by JRC on Sep 24th from 8.45-10.15 CET and -if needed- additional meetings on Sep 28th and/or Oct 12th (9.00-10.30 CET). If not yet invited, please indicate your interest to participate directly to JRC (Ms Galassi) or the SIG leadership team.

Annex 5, paragraphs 4.7. and 4.8., insert to read:

- [4.7. Detect and response to traffic rules and road furniture**
- 4.7.1. These tests shall ensure that the ALKS respects traffic rules, detects and adapts to a variation of permanent and temporary road furniture.**
- 4.7.2. The test shall be executed at least with the list of scenarios below, but based on the ODD of the given system:**
- (a) Different speed limit signs, so that the ALKS vehicle has to change its speed according to the indicated values;**
 - (b) Signal lights of an ending lane. The signal lights are set above the belonging lanes, and the signal lights of adjacent lanes are kept in green state, while the one of the current lane for the ALKS vehicle is kept red;**
 - (c) Driving through a tunnel: at least **[X]**m long section of the road with no sunlight and availability of the positioning system.**
 - (d) Toll station: a section of the motorway with toll station-, speed limit signs and buildings (ticket machines, barriers, etc.).**
 - (e) Temporary modifications: e.g., road maintenance operations indicated by traffic signs, cones and other modifications.**
- 4.7.3. Each test shall be executed at least:**
- (a) Without a lead vehicle;**

(b) With a passenger car target as well as a PTW target as the lead vehicle / other vehicle.

4.8. Avoid braking before a passable object in the lane

4.8.1. The test shall demonstrate that the ALKS vehicle is not braking without a reason before a passable object in the lane (e.g., a manhole lid or a small branch).

4.8.2. The test shall be executed at least:

(a) Without a lead vehicle;

(b) With a passenger car target as well as a PTW target as the lead vehicle / other vehicle.]

Annex 5, paragraph 4.9., insert to read:

[4.9. Oncoming traffic / Wrong way driver

4.9.1. The test shall demonstrate that ALKS is capable of detecting and reacting to oncoming traffic in an adjacent lane.

4.9.2. The test for oncoming vehicle shall be executed at least:

(a) Without a lead vehicle;

(b) With a passenger car target as well as a PTW target as the lead vehicle / other vehicle]

II. Justification
