



Economic and Social Council

Distr.: General
Date ?

Original: English

Economic Commission for Europe

Inland Transport Committee

World Forum for Harmonization of Vehicle Regulations

Working Party on General Safety Provisions

122nd session

Geneva, 12 October–15 October 2021

Item ? of the provisional agenda

Awareness of the proximity of Vulnerable Road Users

Proposal for a new UN Regulation on uniform provisions concerning the approval of motor vehicles with regard to their Direct Vision

Submitted by the Informal Working Group on Awareness of Vulnerable Road Users proximity in low speed manoeuvres*

The text reproduced below was prepared by the Informal Working Group (IWG) on Awareness of Vulnerable Road Users proximity in low speed manoeuvres (VRU-Proxi) to establish a new UN Regulation on Direct Vision.

* In accordance with the programme of work of the Inland Transport Committee for 2020 as outlined in proposed programme budget for 2020 (A/74/6 (part V sect. 20) para 20.37), the World Forum will develop, harmonize and update UN Regulations in order to enhance the performance of vehicles. The present document is submitted in conformity with that mandate.

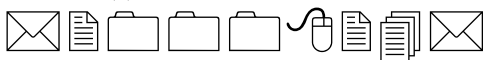

I. Proposal

UN Regulation No. [XXX]

Uniform provisions concerning the approval of motor vehicles with regard to their Direct Vision

0. Introduction (for information)

- 0.1. Collisions between vulnerable road users (VRU) and large commercial vehicles that are undertaking low speed manoeuvres, such as turning or moving off from rest, typically occur at low driving speeds. They usually have serious consequences for vulnerable road users (VRU). In the past, the safety of VRU in these situations was increased by an improvement of the driver's indirect vision (blind spot mirrors) and by equipping trucks with side underrun protection. However, these low-speed manoeuvring collisions still happen so further improvements have been considered necessary.
- 0.2. The cause of this type of collision can be contributed to by many factors. The VRU may have been positioned in a place where they were not available to be seen by the driver through either glazed areas or mirrors. Alternatively, they may have been available to be seen during the build-up to the collision but the driver may have detected their presence too late to avoid collision, or may have failed to detect their presence at all. This late detection, or failure to detect, could be a result of the driver failing to look, looking but failing to see, or seeing but failing to correctly judge the risk.
- 0.3. Elimination of this type of collision may consider action that mitigates many of these different causes. Other regulations have been introduced concurrently to use electronic sensing systems to detect a VRU in close proximity to the vehicle and to inform the driver of their presence via a low urgency information signal (e.g. light) and to provide a collision warning (e.g. audio-visual) when the situation becomes more critical.
- 0.4. Blind spot information systems and collision warnings will be most effective when they draw the attention of the driver to a hazard that can be seen and quickly identified as a valid threat. For many VRU collision situations with many designs of vehicle preceding this regulation, the VRU will not be directly visible through the front or side windows of the vehicle. Many will be visible in mirrors but the evidence suggests that this is not sufficient to prevent all collisions.
- 0.5. Visibility in mirrors can be very beneficial but suffers several limitations compared with direct vision. Human vision has evolved on the basis of two main zones of vision. Foveal vision is the high-resolution area at the centre of the view that is used to see and recognise objects. Peripheral vision contains much less detail but is very sensitive to movement and uses the detection of movement to quickly draw attention and to focus foveal vision on the threat. In the context of this regulation, it is nature's own collision warning system. Images in mirrors are small and may not show sufficient motion to trigger peripheral vision. They must be deliberately and actively scanned by the driver. Mirrors allow only limited depth perception. Images from convex mirror lenses may be distorted, particularly around the edges, and blind spot mirrors may be positioned in counter-intuitive positions with unexpected orientations of the subject. For example, the driver may need to look up towards the vehicle roofline, to see an image that looks down on the top of the head of a cyclist positioned alongside the vehicle. The use of well specified camera monitor systems to replace mirrors can improve on some but not all of these aspects. Research has suggested that where VRUs in close proximity are available to be seen around the front or side of a commercial vehicle, the driver's reaction

time is substantially less when they are available to be seen in direct vision compared with being available to be seen in mirrors.

- 0.6 Therefore, this UN Regulation asks for commercial vehicles that meet certain minimum standards of direct vision, in order to maximise the chances of a driver recognising and quickly reacting to the presence of a VRU in critical situations during low speed manoeuvring. It also seeks to maximise the effectiveness of blind spot information systems and collision warnings.
- 0.7 However, in some circumstances, it will be significantly challenging for vehicle manufacturers to provide good direct vision without compromising other important operational characteristics, such as driver comfort and wellbeing, high power/cooling for high-capacity transport or high ground clearance for off-road operation. The evidence strongly suggests that the vast majority of potentially relevant close proximity manoeuvring collisions occur in major conurbations and very few on major inter-urban roads. As such, the Regulation has set out differing performance levels for different subcategories of vehicle, based on criteria considered highly likely to be indicative of the likelihood that they will be regularly used in urban areas and recognising certain operational limitations.
- 0.8 The Regulation recognises that enabling direct vision of any part of a VRU could potentially help a driver to recognise their presence and avoid a collision. In particular, it is considered that innovations such as windows in the lower panels of doors, that help to see VRUs adjacent to the vehicle at around waist height can be beneficial. For this reason, the Regulation calls for a minimum volume of space around the vehicle to be visible rather than simply visibility of an indicator representing head height, or an area on the floor as is the case for other visibility regulations. The use of a volumetric assessment method provides more flexibility for industry to innovate in their provision of the minimum required view.
- 0.9 While the volumetric assessment method and its assessment zones is derived from the geometrical conditions and installation of devices for indirect vision, specifically mirrors of classes V and VI, of large trucks, the scope of this regulation at its “lower” end also includes vehicles of categories M2 and N2 that are derived from vehicles of categories M1 and N1. These vehicles meet or will soon have to meet Regulation No. 125, equally addressing the direct vision of the driver. To avoid duplicate regulation, these vehicles should therefore be allowed to use compliance to Regulation No. 125 to meet this Regulation. For those vehicles however not derived from M1 or N1, as these vehicles are usually not fitted with devices for indirect vision of classes V and VI and as the eye-point positions defined for large trucks may not be representative to these vehicles it is further proposed to include an alternative assessment method. Noting that the vehicles in this category, due to their relatively low seating positions, robustly overachieve the requirements of this regulation, and as the accident statistics for them did not highlight any increased risks associated with direct vision, it is deemed that a simplified alternative method can be justified for such vehicles, but sufficient to not leave them un-regulated and to avoid bad designs.0.9

Met opmerkingen [MJ(1): Justification for alternative methods for M2/N2 vehicles

1. Scope

- 1.1. This Regulation applies to the approval of vehicles of categories M₂, M₃, N₂ and N₃ with regard to their Direct Vision with the aim of eliminating blind spots to the greatest possible extent possible, considering the needs of the specific type of vehicle and the operation it is intended for.
- 1.2. The requirements of this Regulation are so worded as to apply to vehicles which are developed for right-hand traffic. In vehicles that are developed for left-hand traffic, these requirements shall be applied by inverting the criteria, when appropriate.
- 1.3. Vehicles in small volumes and aimed for special purposes are exempted

Example 1

Example 2]

2. Definitions

For the purposes of this Regulation:

- 2.1. "Direct Vision means the field of vision from the drivers eye point that can be seen through all the glazing situated in front of a vertical plane positioned perpendicular to the longitudinal plane of the vehicle at a distance of 1m behind the driver's eye point (E2).
- 2.2. "Vehicle type with regard to its Direct Vision" means vehicles which do not differ in such essential respects as:
- (a) The manufacturer's trade name or mark;
 - (b) The dimensions and shapes of the components of the vehicle structure situated in front of a vertical plane positioned 1m behind the driver's eye point (E2) and perpendicular to the longitudinal plane of the vehicle;
 - (c) The distance in the X axis between the centre of the front axle of the vehicle and the foremost point of the vehicle;
 - (d) The number, size, shape or location of transparent areas of the vehicle situated in front of a vertical plane positioned 1m behind the driver's eye point (E2) and perpendicular to the longitudinal plane of the vehicle;
 - (e) The direct vision level, as defined by the table in Annex 5, that the vehicle will fall into;
 - (f) The use of mirrors or camera monitor devices replacing Class V and Class VI mirrors as defined in UN ECE Regulation no. 46.]
- 2.3. "Driver's eye point" or "E point" means a point representing the mid-point between the centre of the driver's left and right eye. Three separate eye points, are defined. E2 is the forward eye point, E1 is the left side eyepoint and E3 is the right side eyepoint. Each point is defined using the three-dimensional reference system. E2 is defined by an offset from the accelerator heel point of 1163.25 in the Z axis, and 678mm rearward in the X axis. The position of E2 in the Y axis is on a vertical plane, parallel to the median longitudinal plane and passing through the centre of the driver's seat. The P point is defined as being 98 mm rearward of E2 in the X axis. Points E1 and E3 are defined by a 60-degree rotation, to the left and right respectively, about the P-point.

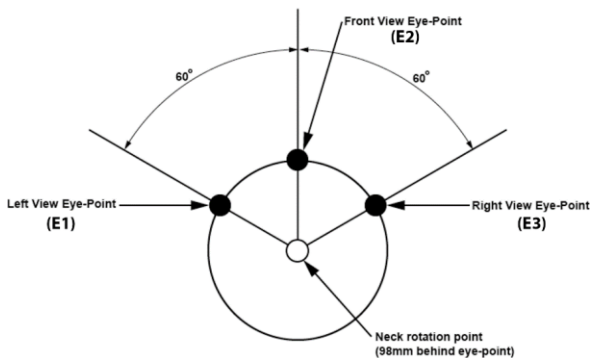

Met opmerkingen [IK2]: The agreement is that this has to be introduced as an amendment but that it should be developed in parallel so that CPs can see what they are deciding on. Ultimately this will be removed from first proposal but introduced in a separate amendment.

Met opmerkingen [IK3]: To be reviewed as Information Document develops

Met opmerkingen [IK4]: This is relevant if any exceptions or deviations are defined for a small number of vehicles based on the use of CMS as an alternative. If not, this can be removed. ACEA/OICA will check other clauses as the information document is developed.

Met opmerkingen [IK5R4]: Now that we know the active safety exemptions must be applied as an amendment does this need to be removed? Or is it still relevant to the M2/N2 lighter touch approach

Figure 1: Definition of E-Points

- 2.4 "Transparent area" means that area of a vehicle windscreen or other glazed surface whose light transmittance measured in a direction perpendicular to the surface is not less than 70 per cent.
- 2.5 "Assessment volume" is the volume of space around the forward part of the vehicle where visibility of part of a vulnerable road user will be considered to contribute to the measurement of the vehicle's direct vision performance. The geometry of the assessment volume is defined in Annex 4.
- 2.6 "Vision occlusion" means any permanently fitted part of the structure of the vehicle, or of the interior of the driver's cabin, that would obstruct a sightline passing from any of the three defined E-Points to any part of the assessment volume.
- 2.7 "Sightline" means a straight line representing the driver's line of sight from an eye point either to a target point or at any particular defined angle within the three-dimensional reference system.
- 2.8 "Vision Opening Line (VOL)" means the intersection of a surface with a sight line that is positioned at a tangent to the first vision occlusion that would obstruct that sightline (e.g. A-pillar, lower edge of windscreen, steering wheel etc).
- 2.9 "Visible volume" means a volume of space, contained entirely within the assessment volume, that is visible via sightlines projected from one of the E-Points through a transparent area of the vehicle positioned no more than 1m to the rear of the point E2, excluding sightlines that are blocked by a vision occlusion. The visible volume is the sum of visible volumes to the nearside, the front and the offside of the vehicle.
- 2.9.1 The "Visible Volume (nearside)" is the portion of the visible volume that can be seen by a sightline projected from the point E1, through any transparent area positioned to the rear of the A-pillar on the near side of the vehicle and less than 1m to the rear of the points E2, where the view from the driver's seat would predominantly lie outboard of the nearside plane of the vehicle.
- 2.9.2 The "Visible Volume (front)" is the portion of the visible volume that can be seen by a sightline projected from the point E2, through any transparent area positioned between the two A-pillars of the vehicle where the view from the driver's seat would predominantly lie forward of the frontal plane of the vehicle.
- 2.9.3 The "Visible Volume (offside)" is the portion of the visible volume that can be seen by a sightline projected from the point E3, through any transparent area positioned to the rear of the A-pillar on the offside of the vehicle and less than 1m to the rear of the point E2, where the view from the driver's seat would predominantly lie outboard of the offside plane of the vehicle.
- 2.10 "Engine power" means the maximum net power as defined by UNECE Regulation no. 85.
- 2.11. "Sleeper cab" means a type of cab that has a compartment behind the driver's seat intended to be used for sleeping.
- 2.12 "Day cab" means a type of cab that is not a sleeper cab.
- 2.13 "Three-dimensional reference system" is a coordinate system as defined by appendix 2 to Annex 1 of the Consolidated Resolution on the Construction of Vehicles (R.E.3). In this framework the longitudinal axis of the vehicle is designated the X axis, the lateral axis is the Y axis and the vertical axis is the Z axis.
- 2.14 "H-point Manikin" means a three-dimensional H-Point Machine as defined in Annex 1 of the Consolidated Resolution on the Construction of Vehicles (R.E.3)

- 2.15 "R-Point" means the seating reference point as defined in Annex 1 of the Consolidated Resolution on the Construction of Vehicles (R.E.3)
- 2.16 "Accelerator Heel Point" (AHP) means the lowest point at the intersection of the heel of the foot and the floor of the vehicle, with the shoe positioned on the Undepressed Accelerator Pedal. This shall be measured using the H-Point Manikin and the foot angle (L46) shall be at a minimum of 87 degrees when the manikin H-Point is positioned at the R Point. For vehicles with R Point to heel vertical (H30) greater than 405 mm, the accelerator pedal may be depressed as specified by the manufacturer. If the depressed pedal is used, the foot must be flat on the accelerator pedal.
- 2.17. "P point" means the point about which the driver's head rotates when viewing objects on a horizontal plane at eye level.
- 2.18. "Axle configuration" means a code of the form AxB where A represents the total number of wheel positions available on the vehicle and B represents the total number of wheel positions where tractive force is applied by the vehicle powertrain. Thus, for example, 6x2 represents a 3-axle vehicle with a wheel positioned at each side of the axle (6 wheel positions) with one driven axle (two driven wheel positions). Extended axle configurations considering further sub-variations are included within the basic characteristics. Substituting a number for an X means it represents any number. For example, 10xX includes any axle configuration with five axles.
- 2.19 "Vehicle frontal plane" means a plane perpendicular to the median longitudinal plane of the vehicle and touching the foremost point of the vehicle, disregarding the projection of devices for indirect vision and/or any vehicle parts installed at a height of more than 2m from the ground.
- 2.20. "Near side" means the right side of the vehicle for right-hand traffic or the left side of the vehicle in left-hand traffic.
- 2.21. "Near side Plane" The plane parallel to the median longitudinal plane of the vehicle and touching its most outboard point in the near side direction, disregarding the projection of devices for indirect vision.
- 2.22. "Off side" means the left side of the vehicle for right-hand traffic, or the right side of the vehicle for left-hand traffic.
- 2.23. "Off side Plane" The plane parallel to the median longitudinal plane of the vehicle and touching its most outboard point in the off side direction, disregarding the projection of devices for indirect vision.
- 2.24. "Subject vehicle" means the vehicle being tested
- 2.25 "Intended cab mounting angle" means the pitch and roll angle of the cab floor relative to a horizontal plane with the cab in its nominal design condition.
- 2.26 "V Points" means points whose position in the passenger compartment is determined as a function of vertical longitudinal planes passing through the centres of the outermost designated seating positions on the front seat and in relation to the "R" Point and the design angle of the seat-back, which points are used for verifying compliance with the field of vision requirements.
- 2.27 "A pillar" means any roof support forward of the vertical transverse plane located 68mm in front of the V Points and includes non-transparent items such as windscreen mouldings and door frames, attached or contiguous to such a support.

Met opmerkingen [SS6]: To discuss with Russ. The definition of the AHP was different in our work? If I recall we define an R point that leads to the eye point. When using the equations in SAE1516 and 1517 our R point values lead to a specific foot angle that is used of 37 degree?

Met opmerkingen [CJ7]: R61; External surface means that part of the vehicle forward of the cab rear panel as defined in..., with the exception of the rear panel in itself, and includes such items as the front wings, from bumpers and front wheels

Met opmerkingen [MJ(8): Used for M2/N2 simplified method

Met opmerkingen [MJ(9): Required for M2/N2 simplified method, but I could also see it being used above.

3. Application for approval

- 3.1. The application for approval of a vehicle type with regard to its Direct Vision shall be submitted by the vehicle manufacturer or by their authorized representative.
- 3.2. It shall be accompanied by the documents mentioned below in triplicate and include the following particular:
- 3.2.1. A description of the vehicle type with regard to the items mentioned in paragraph 5., together with dimensional drawings and the documentation as referred to in paragraph 6.1. The numbers and/or symbols identifying the vehicle type shall be specified. A model of information document is shown in Annex 1.
- 3.3. A vehicle representative of the vehicle type to be approved shall be submitted to the Technical Service conducting the approval tests.

Met opmerkingen [CJ10]: Check if this is relevant in case of CAD method.

4. Approval

- 4.1. If the vehicle type submitted for approval pursuant to this Regulation meets the requirements of paragraph 5. below, approval of that vehicle type shall be granted.
- 4.2. The conformity of the requirements in paragraph 5. shall be verified with the test procedure as defined in paragraph 6., however its operation shall not be limited to these test conditions.
- 4.3. An approval number shall be assigned to each vehicle type approved; its first two digits (00 for this Regulation in its initial form) shall indicate the series of amendments incorporating the most recent major technical amendments made to this Regulation at the time of issue of the approval. The same Contracting Party may not assign the same number to another vehicle type within the meaning of paragraph 2.1 above.
- 4.4. Notice of approval or of refusal or withdrawal of approval pursuant to this Regulation shall be communicated to the Parties to the Agreement applying this Regulation by means of a form conforming to the model in Annex 2 to this regulation.
- 4.5. There shall be affixed, conspicuously and in a readily accessible place specified on the approval form, to every vehicle conforming to a vehicle type approved under this Regulation, an international approval mark consisting of:
- 4.5.1. A circle surrounding the letter "E" followed by:
- (a) The distinguishing number of the country which has granted approval;¹ and
 - (b) The number of this Regulation, followed by the letter "R", a dash and the approval number to the right of the circle prescribed in this paragraph;
- or**
- 4.5.2. An oval surrounding the letters "UI" followed by the Unique Identifier.]

Met opmerkingen [CJ11]: Could be removed, as not stated in other similar UN regulations.

¹ The distinguishing numbers of the Contracting Parties to the 1958 Agreement are reproduced in Annex 3 to the Consolidated Resolution on the Construction of Vehicles (R.E.3), document ECE/TRANS/WP.29/78/Rev.6 - www.unece.org/trans/main/wp29/wp29wgs/wp29gen/wp29resolutions.html

- 4.6. If the vehicle conforms to a vehicle type approved under one or more other UN Regulations annexed to the Agreement, in the country which has granted approval under this Regulation, the symbol prescribed in paragraph 4.5. above need not be repeated. In such a case, the UN Regulation and approval numbers and the additional symbols shall be placed in vertical columns to the right of the symbol prescribed in paragraph 4.5. above.
- 4.7. The approval mark shall be clearly legible and be indelible.
- 4.8. The approval mark shall be placed close to or on the vehicle data plate.

5. Specifications

- 5.1. General requirements
- 5.1.1. The visible volume shall be quantified according to the procedures defined in paragraph 6.
- 5.2. Performance requirements
- 5.2.1. Vehicles shall be assigned into one of the following 3 levels in accordance with the table of criteria contained in Annex 5:
- 5.2.1.1 Level 1: Vehicles that often travel in urban areas;
- 5.2.1.2 Level 2: Vehicles that sometimes travel in urban areas but have specific operational limitations;
- 5.2.1.3 Level 3: Vehicles that seldom enter urban areas.
- 5.2.2. Vehicles of each level must achieve visible volumes in excess of the limit values associated with that level as defined by Table 1.

Table 1: Minimum values of visible volume

	Minimum Volume (m ³) by Direct Vision Level		
	1	2	3
Visible Volume (Nearside)	3.4	Not Specified	Not Specified
Visible Volume (Front)	1.8	1.0	1.0
Visible Volume (Offside)	2.8	Not Specified	Not Specified
Visible Volume (Total)	11.2	8.0	7.0

6. Test procedure

- 6.1. The manufacturer shall provide a documentation package which gives access to ... The documentation package shall give sufficient information for the Type Approval Authority to identify the vehicle type and to aid decision-making on the selection of worst-case conditions.
- 6.2. Test conditions
- 6.2.1. The test shall be performed on a flat, dry surface of asphalt or concrete construction.
- 6.2.2. The ambient temperature shall be between 0° C and 45° C.
- 6.2.3. The test shall be performed under visibility conditions that clearly allows targets used to quantify the field of view to be correctly observed by a visible light camera.
- 6.3. Vehicle conditions

- 6.3.1. The subject vehicle shall be the worst-case vehicle of its type in respect of Direct Vision
- 6.3.2. The subject vehicle shall be assessed with the accelerator heel point positioned at a height from the ground that represents the mid-point between the height that the manufacturer calculates it would be at for an unladen chassis cab (without body) and that which the manufacturer calculates it would be at when the vehicle is loaded to its technically permissible design maximum.
- 6.3.3. The vehicle cab shall be positioned at the intended mounting angle.
- 6.3.4. The steering wheel shall be located in the centre of the possible range, considering all axes of adjustment.
- 6.3.5. Mirrors (where applicable) shall be adjusted to meet the views required by UNECE Regulation no. 46.
- 6.3.6. Passenger seat (if fitted):
- 6.3.6.1. For vehicles where a range of passenger seat designs may be specified, the seat selected for evaluation shall be at the discretion of the manufacturer.
- 6.3.6.2. If the position of the seat is adjustable the passenger seat shall be placed at its rearmost lowest position with a backrest angle of 18 degrees from vertical.
- 6.3.6.3. Where the selected passenger seat is foldable, the vehicle may be assessed with the seat in the in-use (deployed) or the not-in-use (stowed) position at the discretion of the manufacturer. The single selected seat position shall be applied throughout the whole assessment.
- 6.3.6.4. Where armrests are adjustable these may be in the in-use (deployed) or the not-in-use (stowed) position at the discretion of the manufacturer.
- 6.3.6.5. Head restraints shall be in the lowest position suitable for normal use in service. They shall not be in a position provided solely for stowage when not in use.
- 6.4. Quantifying the visible volume
- 6.4.1. The visible volume can be quantified indirectly via the physical test method defined in Annex 6.
- 6.4.2. Alternatively, the visible volume can be quantified directly via a virtual test method as defined in Annex 7, or any virtual method which the manufacturer can demonstrate to the satisfaction of the approval authority produces results at least as accurate as the method defined in Annex 7.
- 6.5. Annex 7 provides details of a generic cab and suggested tolerance values that represent one example method that can be used, at the discretion of the manufacturer and approval authority, to demonstrate the accuracy of virtual methods.
- 6.6. In the event of dispute between manufacturer and approval authority concerning the reliability of any method proposed, the approval authority shall specify the method to be used.

Met opmerkingen [JB12]: How to distinguish direct vision features on same type of vehicles like: lower door window variants, camera-monitor systems variants, foldable passenger seat etc.? So worst case depends on the presence of direct vision features.

Met opmerkingen [SS13]: contradicts the Proxy average concept?

Met opmerkingen [IK14R13]: I don't think so but may be ways of putting it better. The vehicle chosen to be assessed shall be the vehicle that produces the highest unladen AHP. But the vision from that vehicle is assessed from the proxy average height

Met opmerkingen [IK15]: MJ comment – is this needed, can it be deleted?

7. Modification of vehicle type and extension of approval

- 7.1. Every modification of the vehicle type as defined in paragraph 2.1. of this Regulation shall be notified to the Type Approval Authority which approved the vehicle type. The Type Approval Authority may then either:
- 7.1.1. Consider that the modifications made do not have an adverse effect on the conditions of the granting of the approval and grant an extension of approval;

- 7.1.2. Consider that the modifications made affect the conditions of the granting of the approval and require further tests or additional checks before granting an extension of approval.
- 7.2. Confirmation or refusal of approval, specifying the alterations, shall be communicated by the procedure specified in paragraph 4.4. above to the Contracting Parties to the Agreement applying this Regulation.
- 7.3. The Type Approval Authority shall inform the other Contracting Parties of the extension by means of the communication form which appears in Annex 2 to this Regulation. It shall assign a serial number to each extension, to be known as the extension number.

8. Conformity of production

- 8.1. Procedures for the conformity of production shall conform to the general provisions defined in Article 2 and Schedule 1 to the 1958 Agreement (E/ECE/TRANS/505/Rev.3) and meet the following requirements:
- 8.2. A vehicle approved pursuant to this Regulation shall be so manufactured as to conform to the type approved by meeting the requirements of paragraph 5. above;
- 8.3. The Type Approval Authority which has granted the approval may at any time verify the conformity of control methods applicable to each production unit. The normal frequency of such inspections shall be once every two years.

Met opmerkingen [C116]: Check if specific requirements need to be set to take into consideration the potential discrepancy between CAD and physical tests.

9. Penalties for non-conformity of production

- 9.1. The approval granted in respect of a vehicle type pursuant to this Regulation may be withdrawn if the requirements laid down in paragraph 8. above are not complied with.
- 9.2. If a Contracting Party withdraws an approval it had previously granted, it shall forthwith so notify the other Contracting Parties applying this Regulation by sending them a communication form conforming to the model in Annex 2 to this Regulation.

10. Production definitively discontinued

If the holder of the approval completely ceases to manufacture a type of vehicle approved in accordance with this Regulation, they shall so inform the Type Approval Authority which granted the approval, which in turn shall forthwith inform the other Contracting Parties to the Agreement applying this Regulation by means of a communication form conforming to the model in Annex 2 to this Regulation.

11. Names and addresses of the Technical Services responsible for conducting approval tests and of Type Approval Authorities

The Contracting Parties to the Agreement applying this Regulation shall communicate to the United Nations Secretariat the names and addresses of the Technical Services responsible for conducting approval tests and of the Type Approval Authorities which grant approval and to which forms certifying approval or extension or refusal or withdrawal of approval are to be sent.

Annex 1

Information document for type approval of a vehicle with respect to its Direct Vision

The following information, if applicable, shall be supplied in triplicate and shall include a list of contents.

Any drawings shall be supplied in appropriate scale and in sufficient detail on size A4 paper or on a folder of A4 format.

Photographs, if any, shall show sufficient details.

1. Make (trade name of manufacturer):
2. Type and general commercial description(s):
3. Means of identification of the type, if indicated on the device:
4. Category of vehicle for which the device is intended:
5. Name and address of manufacturer:
6. Location and method of affixing of the approval mark:
- 6.1. Other mean of identification link to the approval mark:
7. Address(es) of assembly plant(s):
- ...

Met opmerkingen [CJ17]: EC request to take EU 2020/683 numbering and titles, for consistency.

Met opmerkingen [IK18]: MJ comment – meaning?

Met opmerkingen [IK19]: MJ Comment - meaning

Met opmerkingen [CJ20]: Identify relevant items for Direct Vision (cab drawings, tyre sizes, suspension types, sleeper/day cab, drawings of glazed areas, mirrors/CMS...)

Annex 2

Communication

(Maximum format: A4 (210 x 297 mm))

issued by: (Name of administration)



.....
.....
.....

- Concerning: ²
- Approval granted
 - Approval extended
 - Approval refused
 - Approval withdrawn
 - Production definitively discontinued

of a type of vehicle with regard to its Direct Vision pursuant to UN Regulation No. [XXX]

Approval No.:

1. Trademark:
2. Type and trade name(s):
3. Name and address of manufacturer:
4. If applicable, name and address of manufacturer's representative:
5. Brief description of vehicle:
6. Date of submission of vehicle for approval:
7. Technical Service performing the approval tests:
8. Date of report issued by that Service:
9. Number of report issued by that Service:
10. Reason(s) for extension (if applicable):
11. Approval with regard to Direct Vision is granted/refused:²
12. Place:
13. Date:
14. Signature:
15. Annexed to this communication are the following documents, bearing the approval number indicated above:
16. Any remarks:

¹ Distinguishing number of the country which has granted/extended/refused/withdrawn an approval (see approval provisions in this Regulation).

² Strike out what does not apply.

Annex 3

Arrangements of approval marks

(see paragraphs 4.5. to [4.5.2.] of this Regulation)

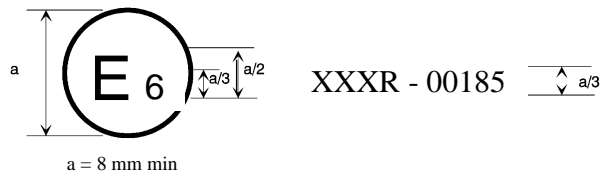

The above approval mark affixed to a vehicle shows that the vehicle type concerned has been approved in Belgium (E6) with regard to Direct Vision pursuant to UN Regulation No. [XXX]. The first two digits of the approval number indicate that the approval was granted in accordance with the requirements of UN Regulation No. [XXX] in its original form.

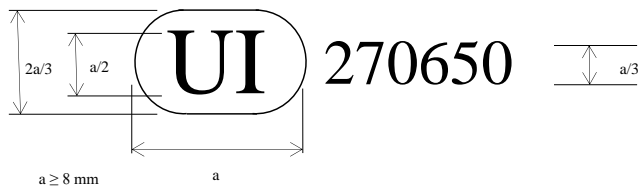

The above Unique Identifier shows that the type concerned has been approved and that the relevant information on that type-approval can be accessed on the UN secure internet database by using 270650 as Unique Identifier. Any leading zeroes in the Unique Identifier may be omitted in the approval marking.

Annex 4 Assessment volume

1. The assessment volume shall be defined as the volume of space between the frontal, nearside and offside plane of the vehicle and the horizontal and vertical boundaries of the assessment zone as defined below and illustrated in Figure 2.
- 1.1 The forward boundary of the assessment zone shall be formed by a plane parallel to the vehicle frontal plane and positioned 2m forward of the vehicle frontal plane.
- 1.2 The nearside boundary of the assessment zone shall be formed by a plane parallel to the vehicle nearside plane and positioned 4.5m further to its' nearside.
- 1.3 The offside boundary of the assessment zone shall be formed by a plane parallel to the vehicle offside plane and positioned 2m further to its' offside.
- 1.4 The rearward boundary of the assessment zone shall be formed by a plane parallel to the vehicle frontal plane and positioned 1.0m behind the driver's eyepoint (E2)
- 1.5 The vertical boundaries of the assessment zone shall be formed by the ground plane and a plane parallel to the ground plane but positioned 1.602m above the ground.

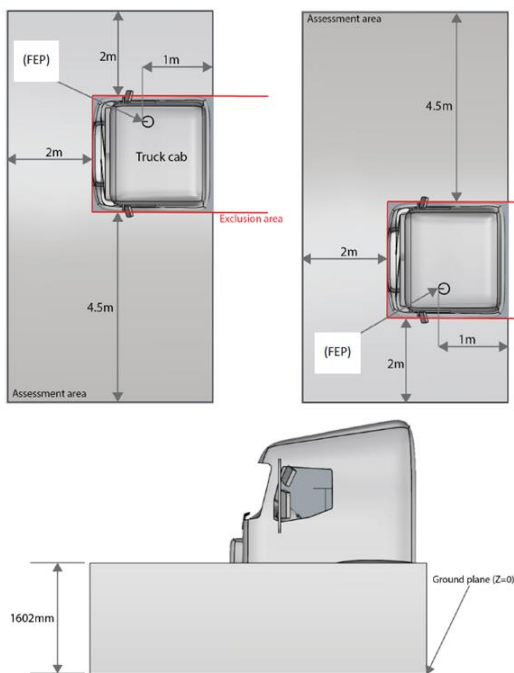

Figure 2: Definition of Assessment Volume

Met opmerkingen [IK21]: Needs revision – exclusion zone is frontal plane, nearside plane etc FEP is E2. Arguable we could more neutrally represent front portion of vehicle (m2, m3, N2, N3) as now defined in text rather than truck specifically. Though truck is of course a valid example

Annex 5 Assigning vehicles to direct vision levels & compliance methods

1.0 Assignment of direct vision levels shall be according to Table 2, below.

Table 2: Assignment of vehicles to direct vision levels

	Gross Weight (tonnes)	Chassis Execution	Axle Config	Engine Power (kW)	Cab type	Vehicle Category	
Level 1	All	All	All	All	All	N2	
	All	All	All	All	All	M2	
	All	All	All	All	All	M3	
	≤16	All	4x2 6x2 6x4 8x2 8x4	All	All	N3	
	>16	Articulated	4x2	All	Day	N3	
				<265	Sleeper	N3	
			6x2	All	Day	N3	
			Rigid	4x2	All	Day	N3
		<265			Sleeper	N3	
		6x2		All	Day	N3	
		6x4 8x2 8x4		All <[350]	Day Sleeper	N3 N3	
		≤16	All	4x2 6x4 8x4	All	All	N3G
	>16	Articulated	4x2	All	Day	N3G	
				<265	Sleeper	N3G	
		Rigid	4x2	All	Day	N3G	
				<265	Sleeper	N3G	
			6x4 8x4	All <[350]	Day Sleeper	N3G N3G	
			Level 3	>16	Articulated	4x2	≥265
	6x2	All				Sleeper	N3
	6x4 8x2 8x4	All				All	N3, N3G
Rigid	4x2	≥265				Sleeper	N3, N3G
	6x2	All			Sleeper	N3	
	6x4 8x2 8x4	≥[350]			Sleeper	N3, N3G	
	All	All			4x4 6x6 8x6 8x8 10xX	All	All

[Swedish proposal for amendments

	Gross Weight	Chassis Execution	Axle Configuration	Engine Power	Cab Execution	Vehicle Category
Level 1	>16 tonnes	Rigid	6x4 8x2 8x4	<[350] kW	Day	N3
Level 2	> 16 tonnes	Rigid	6x4 8x4	<[350] kW	Day	N3G
Level 3	> 16 tonnes	Rigid	6x4 8x2 8x4	≥[350] kW	Day	N3, N3G
				All	Sleeper	N3, N3G

1

- 2 Eligibility for use of the alternative demonstration of compliance
- 2.1 Vehicles of category M2 and N2 [and M3] [not equipped with either mirrors of Class V or VI according to Regulation UN R-46] may be deemed to comply with the requirements when at least one of the following conditions are met:
- 2.1.1 When measured according to the following procedure the maximum height from ground of the lower edge of the (unobstructed) passenger side glazing aperture, is lower than [145cm]
- 2.1.1.1 [Placeholder for procedure]
- 2.1.2 When measured according to the following procedure, the height of the vertical distance between the lower edge of the transparent area at the nearside of the vehicle and the V2-point, is not lower than [26cm]
- 2.1.2.1 Placeholder for measurement procedure
- 2.1.3. They comply with requirements of UN Regulation No. 125 as set out for vehicles of categories M1 and N1. In such a case, the [actions / proof of concept to be done (refer to a paragraph)].
- 2.1.4 In case of 2.1.1 and 2.1.2. additionally the following requirement shall be met: A 1,200 mm tall cylindrical object with a diameter of 300 mm that is situated inside the space bounded by a vertical plane located 2,000 mm in front of the vehicle, a vertical plane located 2,300 mm in front of the vehicle, a vertical plane located 400 mm from the driver's side of the vehicle, and a vertical plane located 600 mm from the opposite side of the vehicle shall be at least partially visible when viewed directly from V2 (see Figure 1), regardless of where the object is within that space, unless it is invisible due to a blind spot(s) created by the A pillars, windscreen wipers, or steering wheel.
- If the driver's seat is located in the central driving position of the vehicle, the 1,200 mm tall cylindrical object shall be situated inside the space bounded by a vertical plane located 2,000 mm in front of the vehicle, a vertical plane located 2,300 mm in front of the vehicle, a vertical plane located 500 mm from the side of the vehicle (see Figure 2).

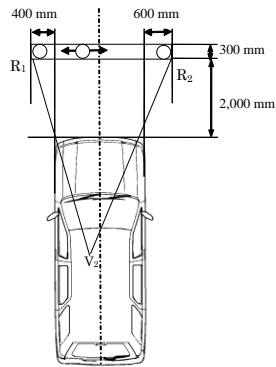

Figure 1:

Met opmerkingen [IK22]: Correct figure refs and title

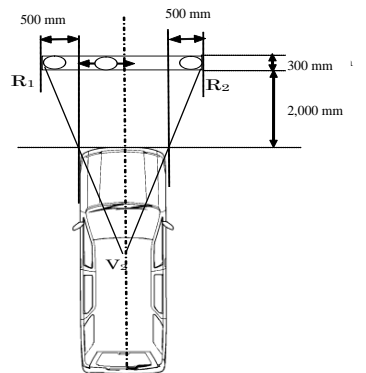

Figure 2:

1

2.2. Position of the V2 point

2.2.1. The position of the V2 point in relation to the "R" point, as indicated by XYZ coordinates from the three dimensional reference grid, are as shown in Tables I and IV.

2.2.2. Table I indicates the basic coordinates for a design seat-back angle of 25°. The positive direction for the coordinates is indicated in Annex 4, Appendix, Figure 1.

Table I

V-point	X	Y	Z
V ₂	68 mm	-5 mm	589 mm

2.2.3 Correction for design seat-back angles other than 25°

Table II indicates the further corrections to be made to the X and Z coordinates of each V point when the design seat-back angle is not 25°. The positive direction for the coordinates is indicated in Annex ??, Appendix, Figure 1.

Table II

Seat-back angle (in°)	Horizontal coordinates Δx	Vertical coordinates Δz	Seat-back angle (in °)	Horizontal coordinates Δx	Vertical coordinates Δz
5	-186 mm	28 mm	23	-18 mm	5 mm
6	-177 mm	27 mm	24	-9 mm	3 mm
7	-167 mm	27 mm	25	0 mm	0 mm
8	-157 mm	27 mm	26	9 mm	-3 mm
9	-147 mm	26 mm	27	17 mm	-5 mm
10	-137 mm	25 mm	28	26 mm	-8 mm
11	-128 mm	24 mm	29	34 mm	-11 mm
12	-118 mm	23 mm	30	43 mm	-14 mm
13	-109 mm	22 mm	31	51 mm	-18 mm
14	-99 mm	21 mm	32	59 mm	-21 mm
15	-90 mm	20 mm	33	67 mm	-24 mm
16	-81 mm	18 mm	34	76 mm	-28 mm
17	-72 mm	17 mm	35	84 mm	-32 mm
18	-62 mm	15 mm	36	92 mm	-35 mm
19	-53 mm	13 mm	37	100 mm	-39 mm
20	-44 mm	11 mm	38	108 mm	-43 mm
21	-35 mm	9 mm	39	115 mm	-48 mm
22	-26 mm	7 mm	40	123 mm	-52 mm

Met opmerkingen [IK23]: Correct table references

Annex 6

Physical Test Method

0. The physical test method calculates the visible volume by mapping out the area of a horizontal plane through the assessment volume, that is visible from the three E points. The view from each E point is provided by a camera mounted in the specified location. The area that can be seen from each E point is mapped via the visibility of a calibrated marker object positioned on grid lines within the assessment area relevant to each eye point. The resulting visible area is scaled to quantify the visible volume.

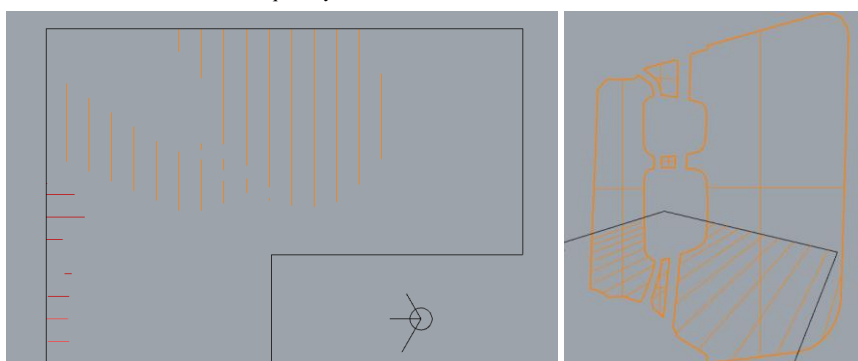

Figure 3. Example of the visible lines identified for the driver's side window

1. Assessment area
 - 1.1 The assessment area shall be defined by a [1] [2] [3] planes parallel to the ground plane [X-Y plane] at a height offset from zero by [i mm] [j mm] [k mm] in Z respectively, bounded by the assessment volume as defined in Annex 4.
2. Assessment area grid
 - 2.1 The assessment area grid is formed by a series of lines parallel to the median longitudinal plane of the vehicle (X) and perpendicular to the median longitudinal plane of the vehicle (Y) spaced at [100mm] intervals, bounded by the assessment areas as defined in 1.1. The grid is divided into three zones: front, nearside, offside.
 - 2.2.1 Assessment area grid front zone
 - 2.2.1.1 The frontal assessment area grid shall be defined as the region of the assessment area forward of the vehicle frontal plane. The grid is formed by lines parallel to the median longitudinal plane of the vehicle (X), spaced as defined in 5.2.5.1.
 - 2.2.2 Assessment area grid nearside zone
 - 2.2.2.1 The nearside assessment area grid shall be defined as the region of the assessment area to the nearside of the vehicle nearside plane. The grid is

Met opmerkingen [IK24]: Exact number and height to be confirmed

formed by lines perpendicular to the median longitudinal plane of the vehicle (Y), spaced as defined in 5.2.5.1.

2.2.3 Assessment area grid offside zone

2.2.3.1 The offside assessment area grid shall be defined as the region of the assessment area to the offside of the vehicle offside plane. The grid is formed by lines perpendicular to the median longitudinal plane of the vehicle (Y), spaced as defined in 5.2.5.1.

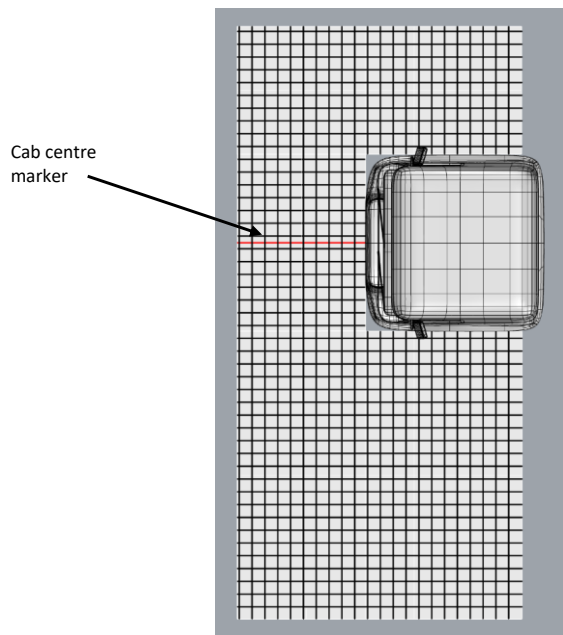

Figure 4. Dividing the assessment area into a grid

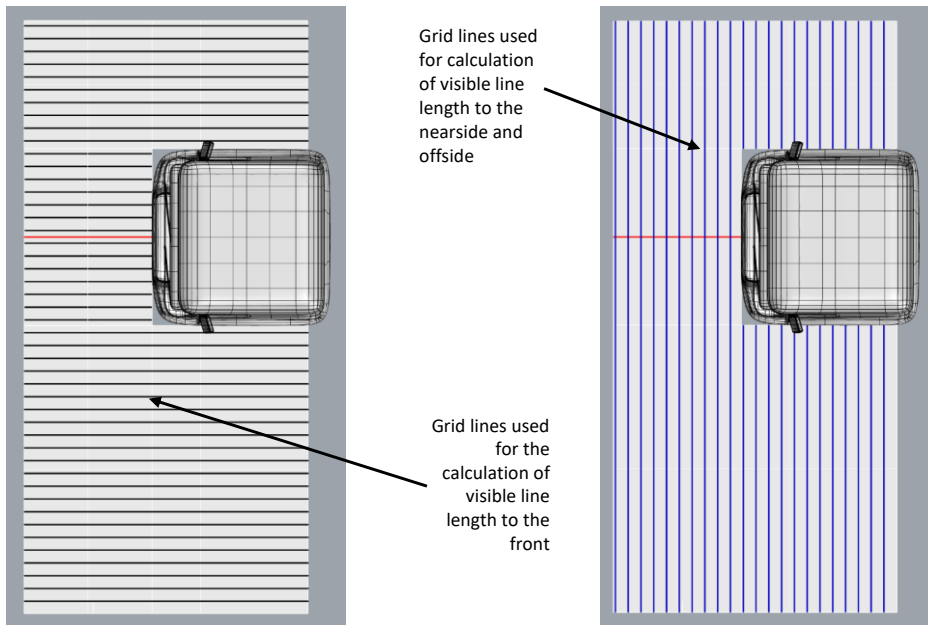

Figure 5. Use of gridlines for assessing different views to each side

3 Visible line length

- 3.1 The visible line length is the sum of the visible line length to each side, as defined in paragraphs 3.2, 3.3 and 3.4.
- 3.2 The visible line length (nearside) is the length of the segments of the gridlines within the assessment area that are visible on the assessment plane from the point E1 and through any transparent area positioned to the rear of the A-pillar on the near side of the vehicle and less than 1m to the rear of the point E2, where the view from the driver's seat would predominantly lie outboard of the nearside plane of the vehicle. Line length measured from the point E1 shall include only lines that are perpendicular to the median longitudinal plane of the vehicle.
- 3.2 The visible line length (front) is the length of the segments of the gridlines within the assessment area that are visible on the assessment plane from the point E2 and through any transparent area positioned between the two A-pillars of the vehicle, where the view from the driver's seat would predominantly lie forward of the frontal plane of the vehicle. Line length measured from the point E2 shall include only lines that are parallel to the median longitudinal plane of the vehicle.
- 3.3 The visible line length (offside) is the length of the segments of the gridlines within the assessment area that are visible on the assessment plane from the point E3 and through any transparent area positioned to the rear of the A-pillar

on the offside of the vehicle and less than 1m to the rear of the points E2, where the view from the driver's seat would predominantly lie outboard of the offside plane of the vehicle. Line length measured from the point E3 shall include only lines that are perpendicular to the median longitudinal plane of the vehicle.

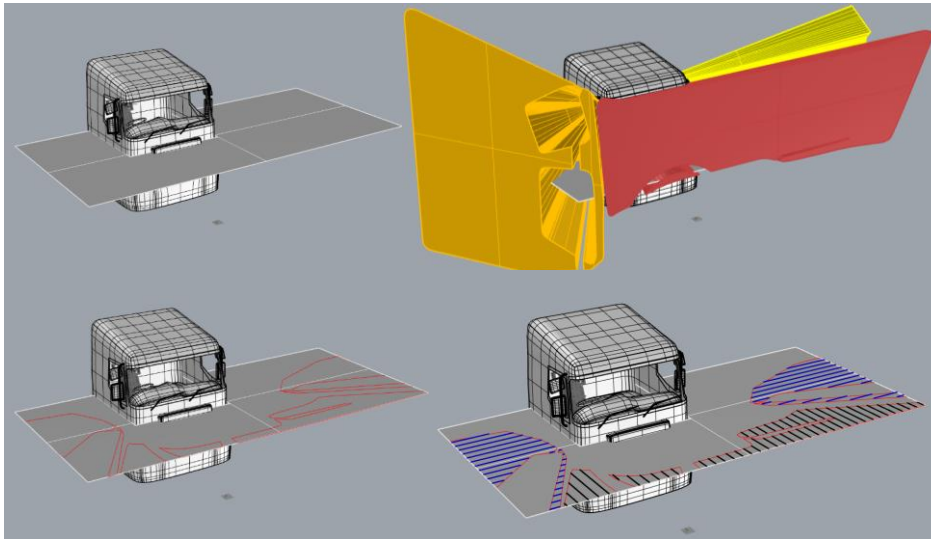

Figure 6. Visible line length to each side representing the intersection of the sightlines projected from the E-points and the assessment area

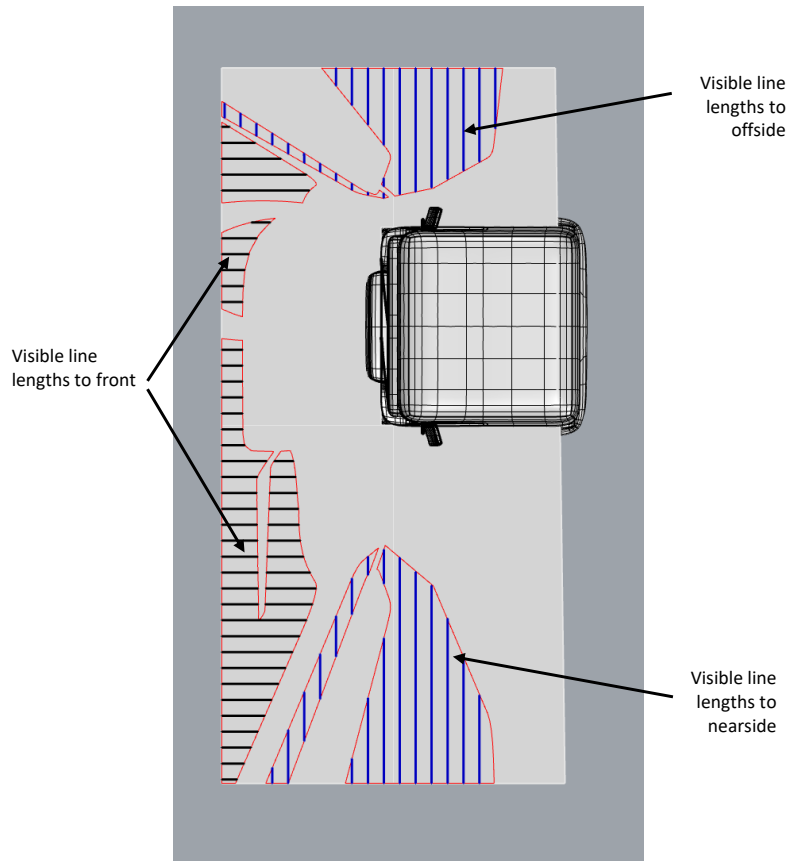

Figure 7: Visible line lengths to each side

- 4. Physical test procedure setup
 - 4.1 Eye point camera specification
 - 4.2.1 The field of view from each of the eye points E1, E2 and E3 shall be monitored by an eye point camera.
 - 4.2.2 The camera will have a field of view to enable all transparent areas to be visible to a given side from the associated E-point.
 - 4.2 Positioning the camera at the Eye points
 - 4.2.1 The eye point cameras shall be positioned at the points E1, E2, & E3.
 - 4.2.2 The method used to achieve this shall be both accurate and robust such that positioning error is minimised.

- 4.2.3 This may be achieved, for example, by use of a physical test apparatus such as that illustrated in [Fout! Verwijzingsbron niet gevonden.](#) below.

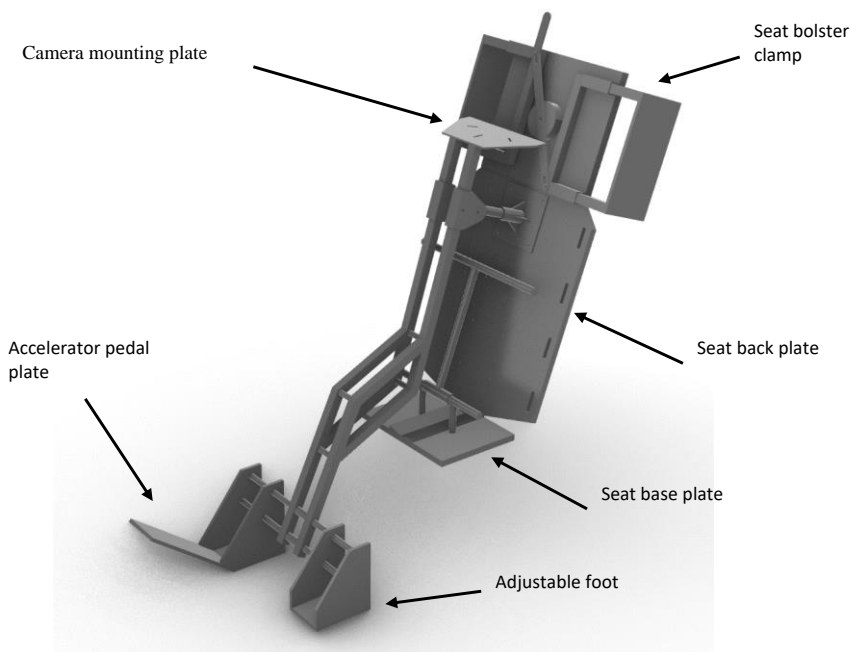

Figure 8. Example of test apparatus suitable for positioning cameras at the defined eye points E1, E2 and E3

- 4.3 Marking the assessment grid
- 4.3.1 The assessment grid shall be marked out on the ground plane by any suitable means (e.g. permanent floor markings, a removable mat suitable aligned to the vehicle or a laser projection onto the floor).
- 4.3.2 The assessment grid shall be transposed to the required height by the use of an appropriate marker object (MO). For example a rigid vertical 30mm diameter pole, mounted perpendicular to a 250mm square baseplate is suitable. The top of the MO must be conspicuous (contrasting colour, high lumen light source) such that it can be easily identified in the eye point camera.
- 4.3.3 The base of the MO should that the centreline of the MO can be easily aligned with the assessment grid.
5. Evaluation procedure
- 5.1 The evaluation consists of moving the MO along each line of the assessment grid and determining the visible line length in the appropriate camera.

- 5.2 The assessment is conducted in three stages: front, nearside / left, offside / right. Each side should be assessed with the relevant camera / E point i.e. front using the front camera / E2, right using the right camera / E3, and left using the left camera / E1:
- 5.3 Determine the working order for the assessment (e.g. front to back, left to right) and incrementally assess the full length of each gridline for visibility.

Determine working order, direction does not matter but consistency is important

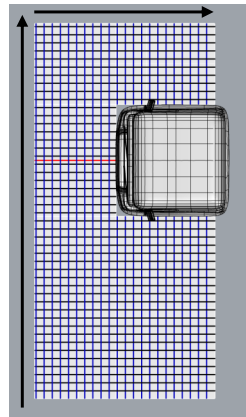

Figure 2. Determine working order in which to progress through the lines on the assessment grid

- 5.4 Take the MO and place it at the maximum extent of the relevant assessment grid on the first appropriate grid line. For example, for the front assessment grid, this might be the bottom left corner of the mat.
- 5.5 Align the marker at the base of the MO with the gridline.

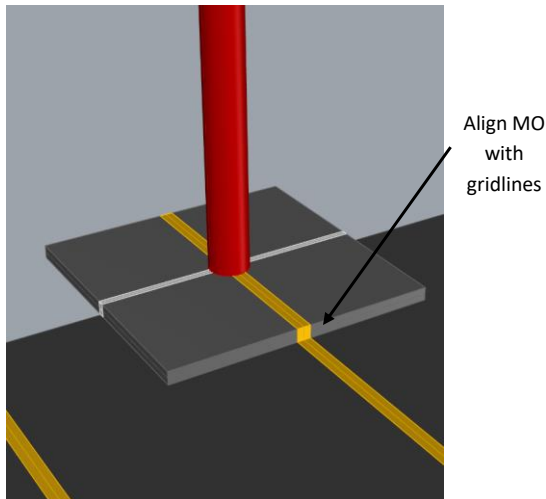

Figure 10. Alignment of the MO with the gridlines.

- 5.6 Using the appropriate camera view assess whether the top of the MO can be seen.
- 5.6.1 If the EH marker can be seen, record the distance from the edge of the assessment area grid to the MO in Table X, if the MO is at the edge of the assessment area, this will be zero.
- 5.6.1.1 This marks the start of the first visible line length for this gridline.
- 5.6.1.2 Move the MO along the line until it reaches the point at which the top is still visible but just about to become obscured by the vehicle structure (see **Figure 11**). Record this distance in Table X.
- 5.6.1.3 This marks the end of the first visible line length for this gridline.
- 5.6.1.4 If the MO reaches the end of the gridline before it becomes obscured, record the distance from the edge of the assessment area to the MO positioned at the end of the gridline.

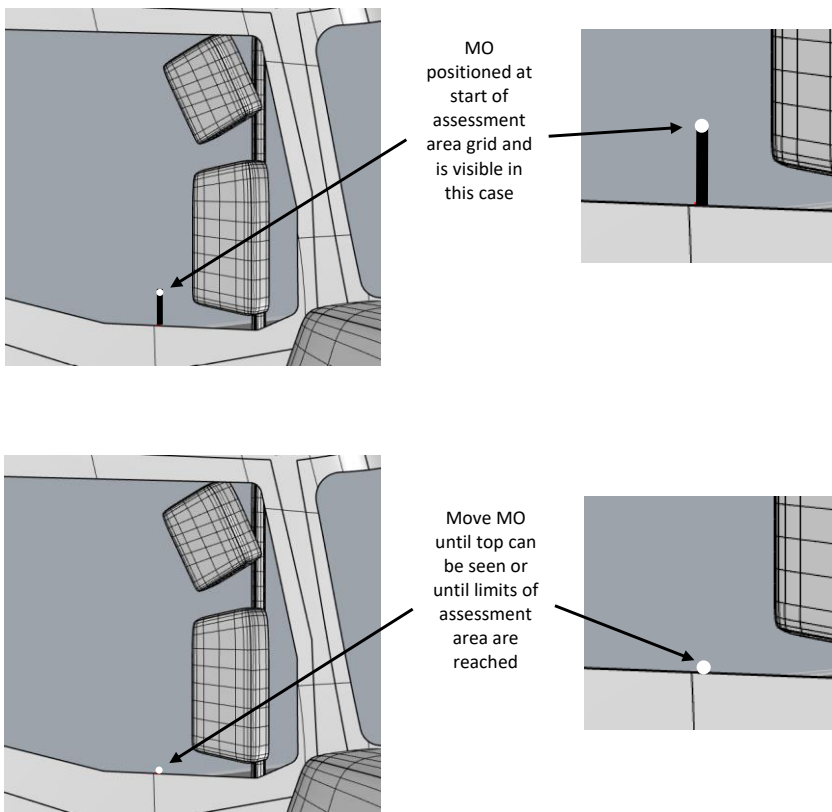

Figure 11. Positioning of MO to identify portions of gridlines in which the EH is visible

- 5.6.2 If the marker cannot be seen, move the MO along the gridline until the point at which the top is visible or until the limits of the assessment area are reached.

- 5.6.2.1 If the top of the MO becomes visible record the distance from the edge of the assessment area grid to the MO in Table X.
- 5.6.2.2 If the top of the MO is not visible across the entire gridline, record 'zero' in Table X and move to the next gridline.
- 5.6.3 For some gridlines there may be multiple visible line lengths on the same gridline. For each visible segment, record the distance from the edge of the assessment area to the start of each visible line and from the edge of the assessment area to the end of each visible line.
- 5.6.4 In some instances the full grid line will be visible. There is no need to capture measurements in this case, merely record 'full' or the appropriate length e.g. 2000mm to the front, 2000mm to the right or 4500mm to the left
- 5.6.5 When assessment of a single gridline is complete, move to the next.
- 5.6.6 Repeat the process for every gridline for each assessment zone, working from one end to the other.
- 5.6.7 The full extent of each zone must be evaluated (see **Figure 12**).

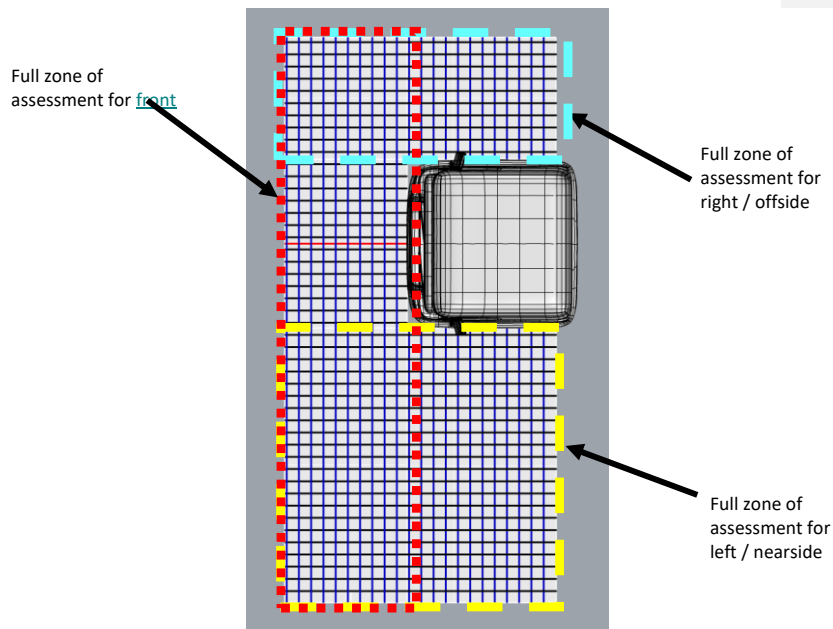

Figure 12. Use of assessment grid zones

Table X

Gridline	Start of first visible line	End of first visible line	Start of second visible line	End of second visible line	Start of n'th visible line	End of n'th visible line

1						
2						
n						

5.7 [Once all visible line lengths have been recorded for all three sides of the assessment area, the process should be repeated for the next assessment area height].

5.8 Once all visible line lengths have been recorded, the summed visible line length (VLL) shall be calculated as follows for each side:

$$VLL = \sum_{1}^{n^{\text{th}} \text{ gridline}} (\text{end of 1st visible line length} - \text{start of 1st visible line length}) + (\text{end of 2}^{\text{nd}} \text{ visible line length} - \text{start of 2}^{\text{nd}} \text{ visible line length}) + (\text{end of n}^{\text{th}} \text{ visible line length} - \text{start of n}^{\text{th}} \text{ visible line length})$$

5.9 For lower door windows and other transparent areas below the assessment area height, the same procedure detailed above should be followed but without the MO. Instead, visible line lengths should be recorded directly on the assessment area grid at the ground plane. These additional visible line lengths should be added to Table X separately for the relevant side.

6.0 Calculating the visible volume

6.1 VLL is converted into Visible volume as follows:

$$\text{Visible volume} = VLL \times \dots$$

Annex 7

CAD Test Method

1. Properties of the model
 - 1.1 The CAD model used in the assessment shall include all necessary features and geometry to provide an accurate representation of what would be visible from the defined eye points in a physical vehicle suitable for sale.
 - 1.2 The CAD model should include all possible vision occlusions.
 - 1.3 The CAD software used is at the discretion of the manufacturer but the manufacturer shall demonstrate to the approval authority that the results produced are reliable. The process of measuring the generic cab defined in Annex 7, paragraph 5 is one example of a method that can be used for that purpose.
2. Create the assessment volume
 - 2.1 The assessment volume shall be created within the CAD environment.
3. Define the vision opening lines.
 - 2.1 The view point within the model shall be positioned at the point E1 for the left view, point E2 for the forward view and point E3 for the right view.
 - 2.2 From this visual perspective, the vision opening line shall be drawn around the edges of the transparent area and its intersections with vision occlusions. Examples are shown in [Figure 13](#), below.

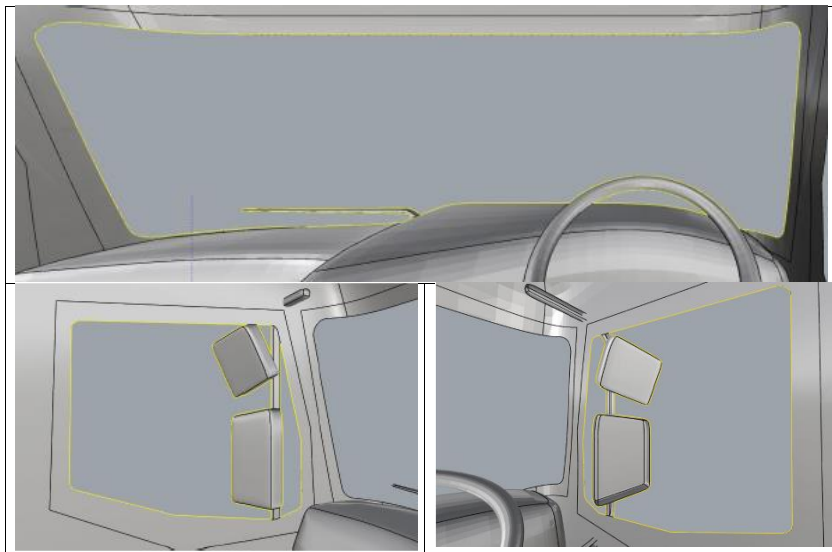
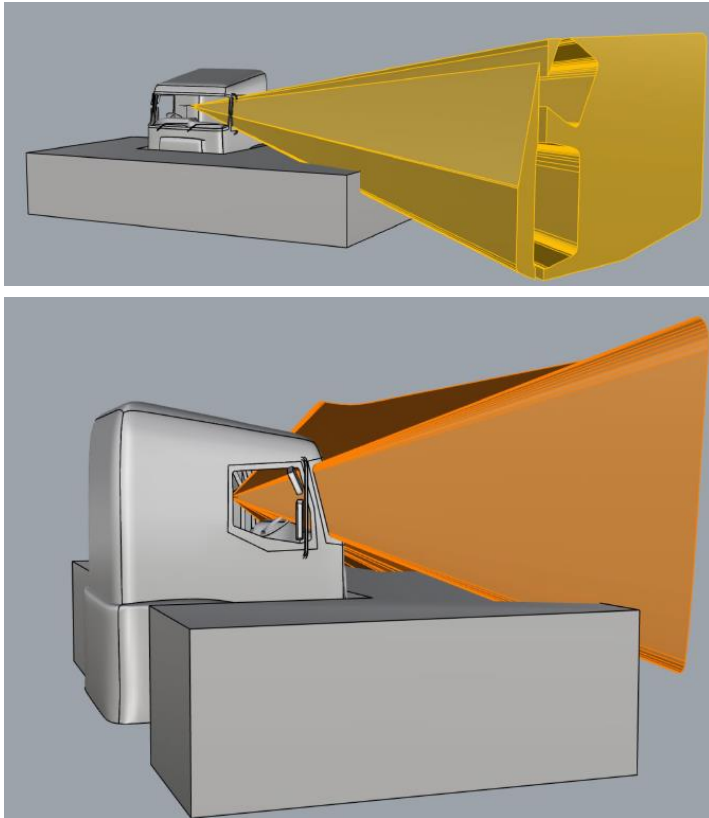

Figure 1345: Examples of drawing vision opening lines (yellow) for the frontal view (top), left view (left) and right view (right) in a CAD environment.

3. Define three-dimensional driver views
 - 3.1 From the eyepoint E1 project sight lines that intersect with the vision opening lines defining the left view from the vehicle, into the space outside of the vehicle until they either meet the ground or project beyond the assessment volume.
 - 3.2 From the eyepoint E2 project sight lines that intersect with the vision opening lines defining the frontal left view from the vehicle, into the space outside of the vehicle until they either meet the ground or project beyond the assessment volume.
 - 3.3 From the eyepoint E3 project sight lines that intersect with the vision opening lines defining the right view from the vehicle, into the space outside of the vehicle until they either meet the ground or project beyond the assessment volume.
 - 3.4 Examples of three-dimensional driver's views are shown in [Figure 14](#) below.



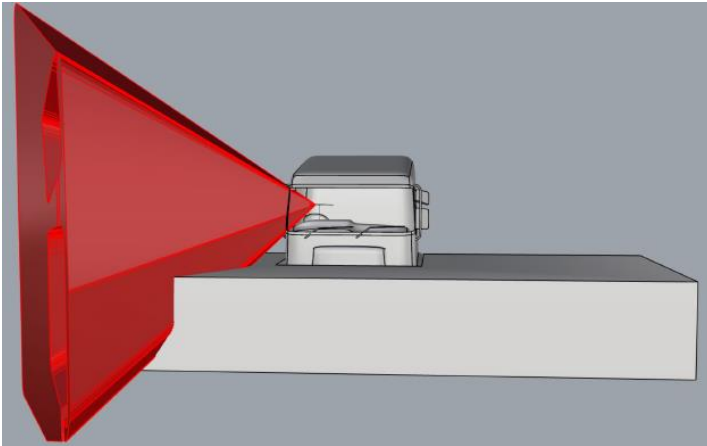

Figure 14: Examples of driver's left view (top), frontal view (middle) and right view (bottom) projected from E1, E2, and E3 | respectively

4. Calculating the visible volume
 - 4.1 Each of the views to the driver's nearside, front, and offside shall be constrained to only those volumes that are within the assessment zone (the visible volume to each side). The remaining volumes of space shall be designated as:
 - 4.1.1 The visible volume (nearside),
 - 4.1.2 The visible volume (front)
 - 4.1.3 The visible volume (offside)
 - 4.2 The total visible volume is the sum of the visible volumes to each side.
 - 4.3 An example of the result is shown in [Figure 15](#) below.

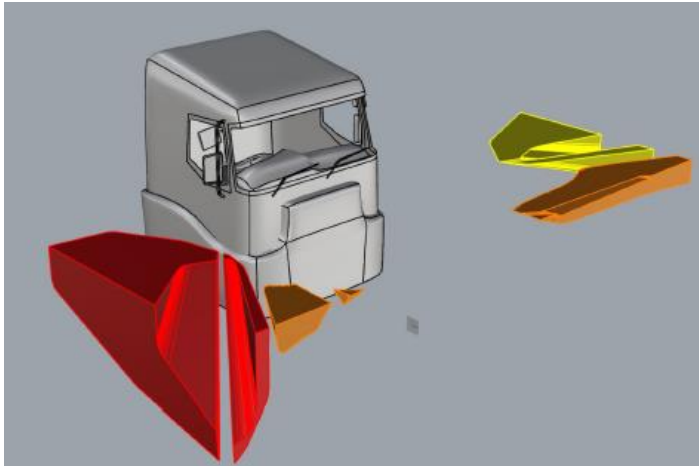

Figure 15: example of visible volume (RHD vehicle. Visible volume (nearside) yellow, front is orange, offside red)

- 5 Using the generic truck model to validate the use of virtual methods.
- 5.1 The process defined in paragraphs 1 to 4 of this annex shall be applied to a standardised generic truck model.
- 5.2 The generic model is illustrated in Figure 16, below.

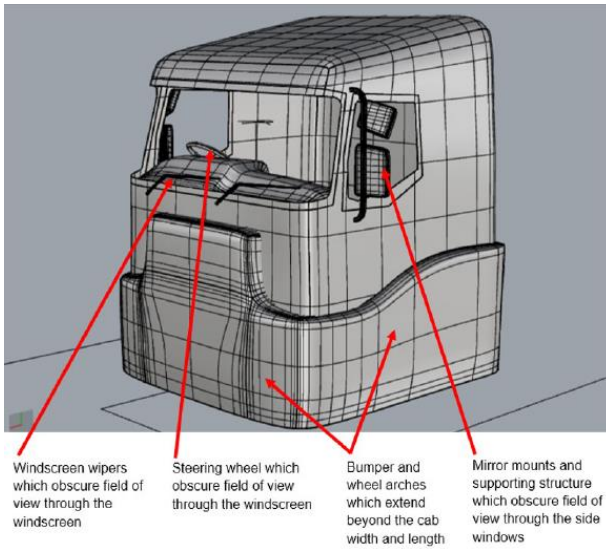

Figure 16: Illustration of the generic cab model

- 5.3 The full 3-d model for use in this assessment is available from....in .stp format
- 5.4 The results of the assessments shall fall within the limits defined in [Table 3](#), below

Met opmerkingen [GU25]: IK - can't see any way around making it available to all somewhere but need to define where and in what formats.

Table 3: Expected nominal results from the assessment of the generic cab and permitted limits

Visible Volume (X)	Expected Volume (mm3)	Permitted range of calculated volume (mm3)	
		Lower	Upper
Nearside	664,547,484	644,611,059	684,483,909
Front	403,613,754	391,505,341	415,722,167
Offside	1,979,890,250	1,920,493,543	2,039,286,958
Total	3,048,051,488	2,956,609,943	3,139,493,033

II. Justification

1.
