

GRSG-122-16 Rev.2 (Clean version)

Proposal for a new UN Regulation on uniform provisions concerning the approval of devices and motor vehicles with regard to the driver’s awareness of vulnerable road users in close-proximity of the front and the side of vehicles

I. Proposal

“ **UN Regulation No. [XXX]**¹

Proposal for a new UN Regulation on uniform provisions concerning the approval of devices and motor vehicles with regard to the driver’s awareness of vulnerable road users in close-proximity of the front and the of vehicles

Contents

*Page***

Regulation

1.	Scope	
1.	Devices for means of front and lateral vision	
2.	Definitions	
3.	Application for approval	
4.	Markings	
5.	Approval.....	
6.	Requirements	
7.	Modification of the type of device for means of front and lateral vision and extension of approval.....	
8.	Conformity of production	
9.	Penalties for non conformity of production	
10.	Production definitively discontinued	
11.	Names and addresses of Technical Services responsible for conducting approval tests, and of Type Approval Authorities	
II.	Installation of means of front and lateral vision or detection.....	
12.	Definitions	

¹ The Regulation number will be known at the time of entry into force of this UN Regulation. [XXX] is intended to be replaced by the Regulation number once known.

** Page numbers will be added at a later stage.

-
13. Application for approval
 14. Approval.....
 15. Requirements.....
 16. Requirements for front and lateral vision camera system
 17. Requirements for detection systems.....
 18. Modifications of the vehicle type and extension of approvals.....
 19. Conformity of production
 20. Penalties for non-conformity of protection
 21. Production definitively discontinued
 22. Names and addresses of Technical Services responsible for conducting approval tests,
and of Type Approval Authorities

Annexes

- 1 Information document for type approval of a device for means of front and lateral vision
- 2 Information document for type approval of vehicle with respect to the installation of
means of front and lateral vision or detection.....
- 3 Communication concerning the approval or refusal or extension or withdrawal of
approval or production definitively discontinued of a type of device (Separate Technical
Unit) for means of front and lateral vision
- 4 Communication concerning the approval or refusal or extension or withdrawal of
approval or production definitively discontinued of a type of vehicle with regard to
means of front and lateral vision or detection.....
- Appendix
- 5 Arrangement of approval mark for a device for means of front and lateral vision.
- 6 Test method for determining reflectivity
- 7 Procedure for determining the radius of curvature "r" of the reflecting surface of a
mirror
- 8 Procedure for determining the "H" point and the actual torso angle for seating positions
in motor vehicles
- Appendix 1 - Description of the three-dimensional "H" point machine (3-D H machine)
- Appendix 2 - Three-dimensional reference system
- Appendix 3 - Reference data concerning seating positions
- 9 Test methods for Close-proximity front and lateral field of vision
- 10 Adjustment Methods for driver's ocular points
- 11 Range of Blind Area Created by the A-Pillar or Exterior Front and lateral side-View
Mirror
- 12 Test Methods for Detection Systems

Introduction (for information)

The purpose of this Regulation is to provide the provisions for enhancing driver's awareness of vulnerable road users at the front and side of the vehicles when the vehicle is taking off from standstill. While UN Regulation No. 46. provides the provisions for indirect vision of motor vehicles, this Regulation expands driver's vision or awareness to the vehicle front and lateral directions before the vehicle is taking off from standstill. Therefore, some requirements of this Regulation may be satisfied by devices complying with UN Regulation No.46.

1. Scope

- 1.1. This Regulation applies to:
 - 1.1.1. Approval of means of front and lateral vision defined in Part I intended to be fitted to vehicles of category M1 and N1.
 - 1.1.2. Approval of vehicle installation of devices of front and lateral vision or detection defined in Part II if fitted to vehicles of category M1 and N1.
 - 1.1.3. At the request of the manufacturer, Contracting Parties may grant approvals under Parts I and II to vehicles, and to the installation of devices for fitting to such vehicles, of other categories and devices for fitting to such vehicles.
- 1.2. Vehicles where installation of means of front and lateral vision or detection is incompatible with their on-road use may be partly or fully exempted from this Regulation, subject to the decision of the Type Approval Authority.
- 1.3. If a vehicle has multiple device(s), the manufacturer shall designate the device that meets the provisions of the regulation.

Part I Devices for means of front and lateral side visibility

2. Definitions

For the purposes of this Regulation:

- 2.1. "*Devices for means of front and lateral vision or detection*" means devices intended to give a clear driver vision of the front and lateral of the vehicle within the fields of vision defined in paragraph 15.2. or intended to detect objects in the field of detection defined in paragraph 15.3.

These can be conventional mirrors, Front and lateral view camera system, detection systems or any other devices having the same purpose.

- 2.1.1. "*Close-proximity front and lateral view device*" means a device that gives the field of vision defined in paragraph 15.2. of this Regulation.

-
- 2.1.2. "Devices for means of front and lateral vision" means devices that present information of the fields of vision defined in paragraph 15.2."
- 2.1.2.1. "Front and Lateral Side view Camera System (FLVCS)" means any system intended to render an image of the outside world and give a clear view to the front and lateral of the vehicle within the fields of vision defined in paragraph 15.2. by means of camera.
- 2.1.2.1.1. "Luminance contrast" means the brightness ratio between an object and its immediate background/surrounding that allows the object to be distinguished from its background/surroundings. The definition is in accordance with the definition given in ISO 9241-302:2008.
- 2.1.2.1.2. "Resolution" means the smallest detail that can be discerned with a perceptual system, i.e. perceived as separate from the larger whole. The resolution of the human eye is indicated as "visual acuity".
- 2.1.2.1.3. "Visual spectrum" means light with a wavelength within the range of the perceptual limits of the human eyes: 380-780 nm.
- 2.1.2.2. "Close-proximity front and lateral view mirror" means any device, excluding devices such as periscopes, intended to give a clear view to the front and lateral side of the vehicle within the fields of vision defined in 2.1.4. and described in paragraph 15.2. by means of a reflective surface.
- 2.1.2.2.1. "r" means the average of the radii of curvature measured over the reflecting surface, in accordance with the method described in Annex 7.
- 2.1.2.2.2. "The principal radii of curvature at one point on the reflecting surface (r_i)" means the values obtained with the apparatus defined in Annex 7, measured on the arc of the reflecting surface passing through the centre of this surface parallel to the segment b, as defined in paragraph 6.1.2.1.2. of this Regulation and on the arc perpendicular to this segment.
- 2.1.2.2.3. "The radius of curvature at one point on the reflecting surface (r_p)" means the arithmetical average of the principal radii of curvature r_i and r'_i , i.e.:
- $$r_p = \frac{r_i + r'_i}{2}$$
- 2.1.2.2.4. "Spherical surface" means a surface, which has a constant and equal radius in all directions.
- 2.1.2.2.5. "Aspherical surface" means a surface, which has only in one plane a constant radius.
- 2.1.2.2.6. "Aspherical mirror" means a mirror composed of a spherical and an aspherical part, in which the transition of the reflecting surface

from the spherical to the aspherical part has to be marked. The curvature of the main axis of the mirror is defined in the x/y coordinate system defined by the radius of the spherical primary calotte with:

$$y = R - \sqrt{(R^2 - x^2)} + k(x - a)^3$$

Where:

R: nominal radius in the spherical part

k: constant for the change of curvature

a: constant for the spherical size of the spherical primary calotte

- 2.1.2.2.7. "*Centre of the reflecting surface*" means the centre of the visible area of the reflecting surface.
- 2.1.2.2.8. "*The radius of curvature of the constituent parts of the mirror*" means the radius "c" of the arc of the circle which most closely approximates to the curved form of the part in question.
- 2.1.2.3. "*Other devices for means of front and lateral vision*" means devices as defined in paragraph 2.1.2.1. to 2.1.2.2.8. above, where the field of vision is not obtained by means of a mirror or a FLCVS.
- 2.1.3. "*Test object*" means a cylindrical object with a height of 1.0 m and a diameter of 0.30 m.
- 2.1.4. "*Field of vision*" means the section of the tri-dimensional space above ground level which is monitored with the help of a device for indirect vision. Unless otherwise stated, this is based on the view offered by a device and/or devices other than mirrors. This may be limited by the relevant detection distance corresponding to the test object.
- 2.1.5. "*Detection System*" means a system which uses signals to enable the driver to detect objects in the area adjacent to the vehicle.
- 2.1.5.1. "*Acoustic information*" means information using auditory signals provided by a detection system as defined in paragraph 2.1.5. above to enable the driver to detect objects in the area adjacent to the vehicle.
- 2.1.5.2. "*Optical information*" means information using optical signals provided by a detection system as defined in paragraph 2.1.5. above to enable the driver to detect objects in the area adjacent to the vehicle.
- 2.1.5.3. "*Haptic information*" means information using haptic signals provided by a detection system as defined in paragraph 2.1.5. above to enable the driver to detect objects in the area adjacent to the vehicle.

2.1.6. "*Field of detection*" means the section of the tri-dimensional space above ground level which is monitored with the help of a detection system.

2.2. "*Type of device for means of front and lateral vision or detection*" means devices that do not differ on the following essential characteristics:

- (a) Design of the device inclusive, if pertinent, the attachment to the bodywork;
- (b) In the case of mirrors, the shape, the dimensions and radius of curvature of the mirror's reflecting surface;
- (c) In the case of Front and lateral side view camera system, the field of view, the magnification.
- (d) In the case of detection systems, the sensor type, the information signal type.

3. Application for approval

3.1. The application for approval of a type of device for means of front and lateral vision shall be submitted by the holder of the trade name or mark or by his duly accredited representative.

3.2. A model of information document is shown in Annex 1.

3.3. For each type of device for means of front and lateral vision the application shall be accompanied by three samples of the parts.

3.4. The manufacturer shall designate the device(s) that are presented for approval to this regulation.

4. Markings

4.1. The samples of devices for means of front and lateral vision submitted for approval shall bear the trade name or mark of the manufacturer; this marking shall be clearly legible and be indelible.

4.2. Every device for means of front and lateral vision shall possess, on at least one of the main components, a space large enough to accommodate the approval mark, which shall be legible; this space shall be shown on the drawings referred to in Annex 1. The approval mark shall also be legible when the device is mounted on the vehicle. Other components of the device shall bear a means of identification. In the case of limited space for the approval mark(s), other means of identification that link it to the approval mark shall be provided.

5. Approval

- 5.1. If the samples submitted for approval meet the requirements of paragraph 6. of this Regulation, approval of the pertinent type of device for means of front and lateral vision shall be granted.
- 5.2. An approval number shall be assigned to each type approved. Its first two digits (at present 00) shall indicate the series of amendments incorporating the most recent major technical amendments made to the Regulation at the time of issue of the approval. The same Contracting Party shall not assign the same number to another type of device for means of front and lateral vision.
- 5.3. Notice of approval or of refusal or of extension or withdrawal of approval or of production definitively discontinued of a type of device for means of front and lateral vision pursuant to this Regulation shall be communicated to the Parties to the Agreement which apply this Regulation by means of a form conforming to the model in Annex 3 to this Regulation.
- 5.4. There shall be affixed, on at least one of the main components, conspicuously and in the space referred to in paragraph 4.2. above, to every device for means of front and lateral vision, conforming to a type approved under this Regulation, in addition to the mark prescribed in paragraph 4.1. above, an international approval mark consisting of:
 - 5.4.1. A circle surrounding the letter "E" followed by:
 - (a) The distinguishing number of the country which has granted approval;² and
 - (b) The number of this Regulation, followed by the letter "R", a dash and the approval number.
- 5.5. The approval mark and the additional symbol(s) shall be clearly legible and be indelible.
- 5.6. Annex 5 to this Regulation gives an example of the arrangement of the aforesaid approval mark and additional symbol.

² The distinguishing numbers of the Contracting Parties to the 1958 Agreement are reproduced in Annex 3 to the Consolidated Resolution on the Construction of Vehicles (R.E.3), document ECE/TRANS/WP.29/78/Rev.6 - www.unece.org/trans/main/wp29/wp29wgs/wp29gen/wp29resolutions.html

6. Requirements

- 6.1. Close-proximity front and lateral vision mirrors
 - 6.1.1. General specifications
 - 6.1.1.1. All mirrors that comply this regulation shall be fixed.
 - 6.1.2. Special specifications
 - 6.1.2.1. Dimensions
 - 6.1.2.1.1. The contours of the reflecting surface shall be of simple geometric form and its dimensions such that the mirror provides the field of vision specified in paragraph 15.2. of this Regulation.
 - 6.1.2.2. Reflecting surface and coefficients of reflection
 - 6.1.2.2.1. The reflecting surface of a mirror shall be either flat or spherically convex. Exterior mirrors may be equipped with an additional aspherical part provided that the main mirror fulfils the requirements of the indirect field of vision.
 - 6.1.2.2.2. Differences between the radii of curvature of mirrors
 - 6.1.2.2.2.1. The difference between r_i or r'_i , and r_p at each reference point shall not exceed 0.15 r.
 - 6.1.2.2.2.2. The difference between any of the radii of curvature (r_{p1} , r_{p2} , and r_{p3}) and r shall not exceed 0.15 r.
 - 6.1.2.2.2.3. When r is not less than 3,000 mm, the value of 0.15 r quoted in paragraphs 6.1.2.2.2.1. and 6.1.2.2.2.2. above is replaced by 0.25 r.
 - 6.1.2.2.2.3. The value of the normal coefficient of reflection, as determined according to the method described in Annex 6, shall be not less than 40 per cent.

In the case of reflecting surfaces with a changeable degree of reflection, the "day" position shall allow the colours of the signals used for road traffic to be recognized. The value of the normal coefficient of reflection in the "night" position shall be not less than 4 per cent.
 - 6.1.2.2.4. The reflecting surface shall retain the characteristics laid down in paragraph 6.1.2.2.3. above in spite of prolonged exposure to adverse weather conditions in normal use.

7. Modification of the type of device for means of front and lateral side visibility and extension of approval

- 7.1. Every modification to an existing type of device for means of front and lateral vision including its connection to the bodywork shall be notified to the Type Approval Authority which approved the type of device for means of front and lateral vision. The Type Approval Authority shall then either:

-
- (a) Decide, in consultation with the manufacturer, that a new type-approval is to be granted; or
 - (b) Apply the procedure contained in paragraph 7.1.1. (Revision) and, if applicable, the procedure contained in paragraph 7.1.2. (Extension).

7.1.1. Revision

When particulars recorded in the information folder have changed and the Type Approval Authority considers that the modifications made are unlikely to have an appreciable adverse effect and that in any case the device for means of front and lateral vision still complies with the requirements, the modification shall be designated a "revision".

In such a case, the Type Approval Authority shall issue the revised pages of the information folder as necessary, marking each revised page to show clearly the nature of the modification and the date of re-issue. A consolidated, updated version of the information folder, accompanied by a detailed description of the modification, shall be deemed to meet this requirement.

7.1.2. Extension

The modification shall be designated an "extension" if, in addition to the change of the particulars recorded in the information folder;

- (a) Further inspections or tests are required; or
- (b) Any information on the communication document (with the exception of its attachments) has changed; or
- (c) Approval to a later series of amendments is requested after its entry into force.

7.2. Confirmation or refusal of approval, specifying the alterations shall be communicated by the procedure specified in paragraph 5.3. above to the Parties to the Agreement which apply this Regulation. In addition, the index to the information package, attached to the communication document, shall be amended accordingly to show the date of the most recent revision or extension.

7.3. The Type Approval Authority issuing the extension of approval shall assign a series number to each communication form drawn up for such an extension.

8. Conformity of production

8.1. The conformity of production procedure shall comply with those set out in the Agreement, Schedule 1 (E/ECE/324-E/ECE/TRANS/505/Rev.3).

8.2. Every device for means of front and lateral vision approved under this Regulation shall be so manufactured as to conform to the type

approved by meeting the requirements set out in paragraph 6.
above.

9. Penalties for non-conformity of production

9.1. The approval granted in respect of a type of device for means of front and lateral vision pursuant to this Regulation may be withdrawn if the requirement laid down in paragraph 8.1. above is not complied with or if the type of device for means of front and lateral vision did not satisfy the requirements prescribed in paragraph 8.2. above.

9.2. If a Contracting Party to the Agreement which applies this Regulation withdraws an approval it has previously granted, it shall forthwith so notify the other Contracting Parties applying this Regulation by means of a copy of the communication form bearing at the end, in large letters, the signed and dated annotation "APPROVAL WITHDRAWN".

10. Production definitively discontinued

If the holder of the approval completely ceases to manufacture a type of device for means of front and lateral vision approved in accordance with this Regulation, he shall so inform the Type Approval Authority which granted the approval. Upon receiving the relevant communication, the Authority shall inform thereof the other Parties to the Agreement applying this Regulation by means of a copy of the approval form bearing at the end, in large letters, the signed and dated annotation "PRODUCTION DISCONTINUED".

11. Names and addresses of Technical Services responsible for conducting approval tests, and of Type Approval Authorities

The Contracting Parties to the Agreement applying this Regulation shall communicate to the United Nations Secretariat the names and addresses of the Technical Services responsible for conducting approval tests and of the Type Approval Authorities which grant approval and to which forms certifying approval or refusal or extension or withdrawal of approval, issued in other countries, are to be sent.

Part II Installation of means of front and lateral vision or detection

12. Definitions

For the purpose of this Regulation:

- 12.1. "The driver's ocular points" means two points 65 mm apart and 635 mm vertically above point R of the driver's seat as defined in Annex 8. The straight line joining these points runs perpendicular to the vertical longitudinal median plane of the vehicle. The centre of the segment joining the two ocular points is in a vertical longitudinal plane which shall pass through the centre of the driver's designated seating position, as specified by the vehicle manufacturer.
- 12.2. "Ambinocular vision" means the total field of vision obtained by the superimposition of the monocular fields of the right eye and the left eye (see Figure 2 below).

Figure 2

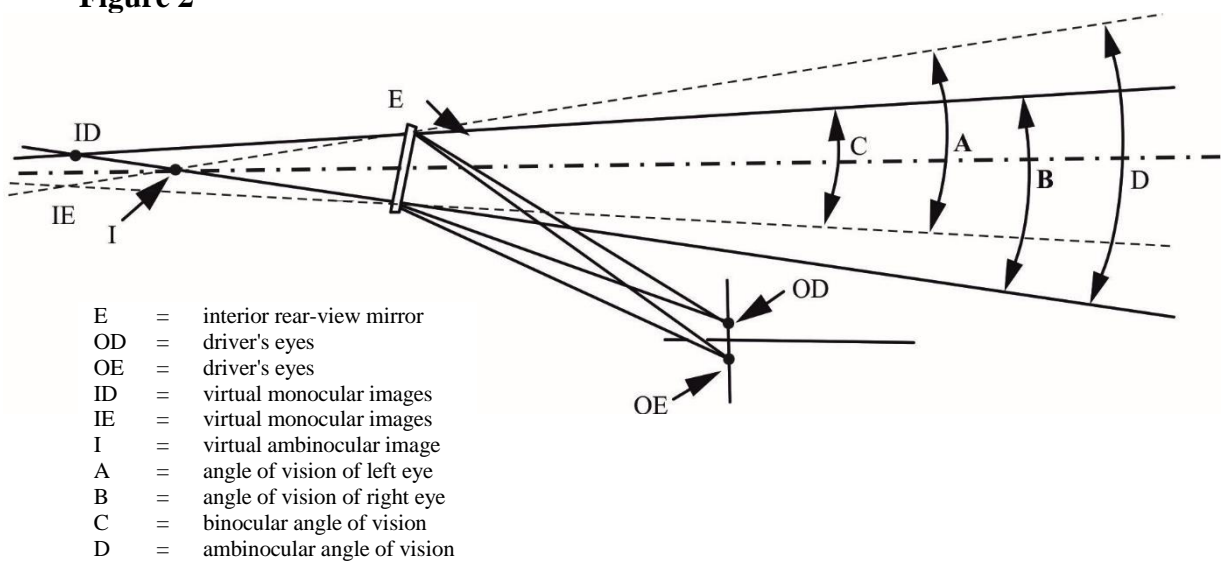

- 12.3. "Type of vehicle as regards to the driver's awareness of vulnerable road users in close-proximity of the front and lateral side of the vehicle" means motor vehicles which are identical in respect of the following basic features:
- 12.3.1. Type of means of front and lateral vision or detection;
- 12.3.2. The bodywork features which reduce the field of vision;
- 12.3.3. The coordinates of point R (where applicable);
- 12.3.4. The prescribed positions, and type-approval markings of compulsory and (if fitted) optional devices for indirect vision.
- 12.4. "The ocular reference point" means the middle point between the driver's ocular points.

-
- 12.5. *"Type of means of front and lateral vision or detection"* means front and lateral side visibility or detection means that do not differ on the following essential characteristics:
- (a) The type of devices of front and lateral vision or detection;
 - (b) The mean of front and lateral vision or detection;
- 12.6. "Electronic system" means a system working depending up on electronic variables like power or voltage or current, and formed of a number of blocks having different input – output relationships connected together.

13. Application for approval

- 13.1. The application for approval of a vehicle type with regard to the installation of means of front and lateral vision or detection shall be submitted by the vehicle manufacturer or by his duly accredited representative.
- 13.2. A model of information document is shown in Annex 2.
- 13.3. A vehicle representative of the vehicle type to be approved shall be submitted to the Technical Service responsible for conducting the approval tests.
- 13.4. The Type Approval Authority shall verify the existence of satisfactory arrangements for ensuring effective checks on conformity of production before type-approval is granted.
- 13.5. The FLVCS shall be provided by the applicant with the following documents:
- (a) Technical specification of the FLVCS;
 - (b) Operator's manual.

14. Approval

- 14.1. If the vehicle type submitted for approval in accordance with paragraph 13. above meets the requirements of paragraph 15. of this Regulation, approval shall be granted.
- 14.2. An approval number shall be assigned to each type approved. Its first two digits (at present 00) shall indicate the series of amendments incorporating the most recent or technical amendments made to the Regulation at the time of issue of the approval. The same Contracting Party shall not assign the same number to another vehicle type.
- 14.3. Notice of approval or of refusal or of extension or withdrawal of approval of a vehicle type pursuant to this Regulation shall be communicated to the Parties to the Agreement which apply this

Regulation by means of a form conforming to the model in Annex 4 to this Regulation.

15. Requirements

15.1. General

For the purposes of this Regulation, the vehicle shall fulfil the following requirements:

The vehicle shall be equipped with at least one means of vision or awareness.

Any means using one or several electronic system(s) (e.g., vision camera systems, detection systems), shall be activated upon the driver's request.

The combination of means of vision provide a close-proximity front and lateral field of vision as defined in paragraph 15.2. These means shall be selected from:

- (a) Direct vision,
- (b) Devices approved to UN Regulation No. 46, 04 Series of amendments,
- (c) Close-proximity front and lateral view mirror complying with this Regulation, and
- (d) Close-proximity front and lateral view camera system complying with this Regulation.

The combination of means of awareness shall provide an information for field of detection as defined in paragraph 15.3 ~~below~~. Possible means are:

These means shall be detection systems complying with this Regulation.

15.2. Close-proximity front and lateral side field of vision

The field of vision (see Figure 3 below) shall be bounded by the following planes:

- (a) A transverse vertical plane passing through a point 300 mm from the contour of the front of the vehicle;
- (b) A transverse horizontal plane passing through a point 300 mm from the contour of the front of the vehicle;
- (c) Areas ahead of the vehicle front and the centre of the side mirrors on the driver's seat side and the passenger seat side. In the case of the vehicle that equipped with CMS that comply UN Regulation No. 46, 04 Series of amendments, the manufacturer shall consider the same vehicle equipped with side mirrors or to use centre of Class II CMS camera lens instead of the centre of the side mirror.

The contour shall be defined by the vehicle outside shape projection to the ground that can place the test object defined in Annex 9 of this regulation (300mm diameter pole). Small outside shape irregularity is not included.

Figure 3

Close-proximity front and lateral side view field of vision

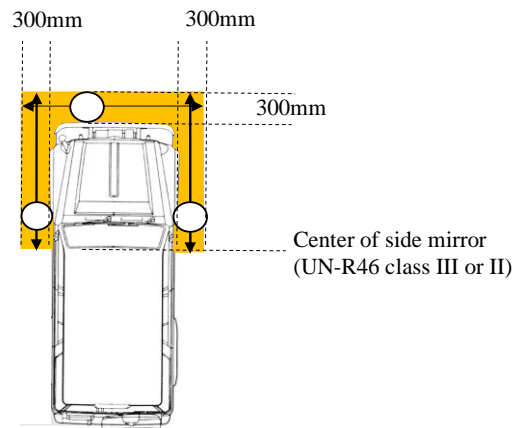

- 15.2.1. Requirements
 - When tested under the test method described in Annex 9, the test object shall be revealed.
 - 15.2.1.1. Via the direct view from ambinocular vision from the adjusted driver's ocular points, or binocular vision from the adjusted ocular reference point calculated by the methods described in Annex 10;,
 - 15.2.1.2. Via a device of indirect vision (mirror or CMS or other) approved to UN Regulation No. 46; or
 - 15.2.1.3. Via a means of indirect vision for front and lateral vision (mirror or camera system or other) complying with this Regulation; or
 - 15.2.1.4. Via a device of detection system; or
 - 15.2.1.5. Via a combination of the means described in the paragraphs 15.2.1.1 to 15.2.1.4. and declared by the manufacturer.
- 15.2.2. Overlaps of designated areas by different means (see examples in Figure 4) are shall be permitted.
- 15.2.3. The manufacturer shall declare to the technical service which means is used for which designated area, so that the technical service can set up the testing equipment accordingly. This shall be recorded in the test report.

Figure 4

Examples of designated area of each means (right-handed drive case)

- (a) In the case of direct vision, detection system, FLVCS.

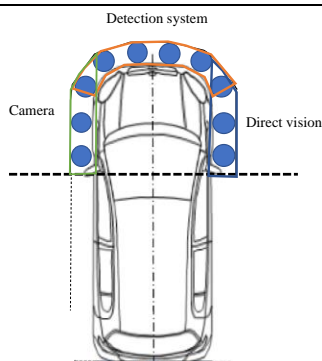

(b) In the case of direct vision and mirror.

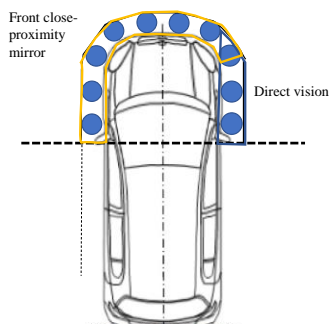

15.2.4. Particular requirements for Close-proximity front and lateral side view camera system and detection system requirements

15.2.4.1. It shall be possible to easily activate the Close-proximity front and lateral side view camera system and the detection system when the gear in the out of parking or neutral range.

15.2.4.2. Close-proximity camera system or detection system that cannot cover all field of means for driver awareness at the same time shall easily show area of the driver's interest by the driver's operations.

It shall be possible to easily activate the close-proximity camera system or detection system. In case their combination cannot cover the full field of view, they shall show at least the area of driver's interest.

15.2.5. The Close-proximity front and lateral ~~side~~ field of vision shall be established using ambinocular vision from the adjusted driver's ocular points, the eyes being at the "driver's ocular points" as defined in paragraph 12.1. or binocular vision from the adjusted ocular reference point. The fields of vision shall be determined when the vehicle is in running order as defined in the consolidated Resolution on the Construction of vehicles (R.E.3) (ECE/TRANS/WP.29/78/Rev.6, para. 2.2.5.4.), plus for M1 and N1 vehicles one front seat passenger (75 kg). When established through windows, the glazing shall have a total light transmission factor in accordance with UN Regulation No. 43, 04 series of amendments, Annex 24.

15.2.6. In the case of mirrors consisting of several reflecting surfaces which are either of different curvature or not in the same plane, at

least one of the reflecting surfaces shall provide the field of vision and have the dimensions specified for the class to which they belong.

15.3. Field of detection

The field of detection shall be bounded by the following curved surfaces and planes (see Figure 5)

- (a) A vertical curved surface passing through a point 200 mm from the contour of the front of the vehicle;
- (b) A vertical curved surface passing through a point 300 mm from the contour of the front of the vehicle;
- (c) Two vertical planes orthogonal to the contour of the vehicle at the manufacturer's setting;

Here, the vehicle contours refer to the ones in the top view of the vehicle.

The contour shall be defined by the vehicle outside shape projection to the ground that can place the test object defined in Annex 9 of this regulation (300mm diameter pole). Small outside shape irregularity is not included.

Figure 5
Field of detection

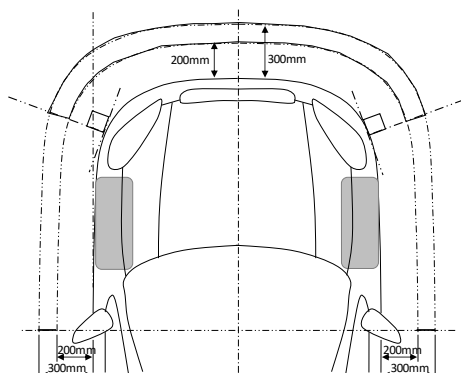

- 15.3.1. When tested under the test method described in Annex 12 the requirements for field of detection shall be considered satisfied if the information as defined in paragraph 17.2 is provided to the driver.
- 15.4. Devices for means of front and lateral vision or detection
 - 15.4.1. Position
 - 15.4.1.1. Devices for means of front and lateral vision or detection shall be so placed that the driver, when sitting on the driving seat in a normal driving position, has a clear view of the road to the front and lateral side(s) of the vehicle.
 - 15.4.1.2. In the case of any vehicle, which is in chassis/cab form when the field of vision or detection is measured, the minimum and maximum recommended body widths, heights and lengths shall be stated by the manufacturer and, if necessary, simulated by

dummy headboards. All vehicles and devices for means of front and lateral vision or detection configurations taken into consideration during the tests shall be shown on the type-approval certificate for a vehicle with regard to the installation of devices for means of front and lateral vision or detection (see Annex 4). This includes information related to a range of device installation positions (in length, width and height).

15.4.1.3. Devices for means of front and lateral vision or detection shall not project beyond the external bodywork of the vehicle substantially more than is necessary to comply with the requirements concerning fields of vision or fields of detection.

15.4.1.4. Devices for means of front and lateral side visibility or detection shall be firmly fitted in such a way that the devices do not move so as to significantly change the field of vision or detection as measured or vibrate to an extent which would cause the driver to misinterpret the nature of the image perceived. Wiring of the devices shall not be exposed on the surface of the vehicle.

15.5. Blind area exemption

Range of blind area created by the A-pillar or exterior rear-view mirror that satisfies the conditions described in Annex 11 of this regulation is excluded from the field of vision or detection.

16. Requirements for front and lateral side view camera system

16.1. System activation

The vehicle shall be equipped with dedicated means for the driver to activate and deactivate the system. The default status of the system shall be the off mode at the initiation of each new engine start/run cycle.

If proper functioning cannot be ensured, the system shall automatically shut off or the driver shall be able to deactivate.

16.2. Default view

In default view the FLVCS shall show at least the part of the field of view as described in paragraph 15.2.

The FLVCS must default to the front and lateral side view image the instruction to activate it is given by the driver.

16.2.1. Luminance and contrast adjustment

If manual adjustment is provided, the operator's manual shall provide information on how to change the luminance/contrast.

16.2.2. Overlay requirements within the required field of vision

Overlays shall display only front and lateral side driving-related visual information or safety-related information. Overlays for other purposes of information in the required field of vision are not allowed.

-
- 16.3. View adjustment
The front and lateral side view image may change the camera view by the driver's operation or automatically without the driver's operations.
- 16.4. Operating readiness (System availability)
The system deactivated status shall be indicated to the driver (e.g. FLVCS failure by, i.e. warning indication, display information, black screen, absence of status indicator). The information for the driver shall be explained in the operator's manual.
- 16.5. Monitor inside the vehicle
The monitor defined size shall be visible without any obstruction from the ocular reference point. Virtual testing is acceptable.
- 16.5.1. Obstruction of the driver's direct view caused by the installation of a device for indirect vision shall be restricted to a minimum.
- 16.6. Vehicles may be equipped with additional devices for indirect vision.
- 16.7. Notwithstanding the provisions above, any other design concept shall be demonstrated to the satisfaction of the Technical Service within the safety concept that is provided in the provisions above.
- 16.8. The effectiveness of the FLVCS shall not be adversely affected by magnetic or electrical fields. This shall be demonstrated by compliance with the technical requirements and transitional provisions of UN Regulation No. 10, 05 series of amendments or any later series of amendments.
- 17. Requirements for detection systems**
- 17.1. System activation
The vehicle shall be equipped with dedicated means for the driver to activate and deactivate the system. The default status of the system shall be the off mode at the initiation of each new engine start/run cycle.
If proper functioning cannot be ensured, the system shall automatically shut off or the driver shall be able to deactivate.
- 17.2. Driver interface and information presentation strategy
- 17.2.1. The system shall have at least two kinds of driver information signal selected from acoustic, optical, and haptics.
- 17.2.1.1. As long as one information signal remains active, the driver may de-activate the other information signals.
- 17.2.2. Acoustic information
When an object is detected in the front and lateral side horizontal area as described in paragraph 1.3. of Annex 12. while the instruction to activate was given by the driver, acoustic

information shall be given.

17.2.3. Duration of signalling

Signalling for an object shall last as long as the object is detected and shall end when the object is no longer detected or when the system is deactivated.

The acoustic signal may be automatically temporarily suspended after a certain time provided that the system remains activated.

17.2.4. Optical information

In the case optical information is displayed on common space used for other information (such as meter cluster display or other displays), overlay is allowed and shall comply with the overlay requirements of the camera system in 16.2.2. of this Regulation.

17.2.5. Operating readiness (System availability)

The system deactivated status shall be indicated to the driver (e.g. Detection system failure by, i.e. warning indication, display information, black screen, absence of status indicator). The information for the driver shall be explained in the operator's manual.

17.3 The effectiveness of the detection system shall not be adversely affected by magnetic or electrical fields. This shall be demonstrated by compliance with the technical requirements and transitional provisions of UN Regulation No. 10, 05 series of amendments or any later series of amendments.

18. Modifications of the vehicle type and extension of approval

18.1. Every modification of the vehicle type shall be notified to the Type Approval Authority which approved the vehicle type. Type Approval Authority shall then either:

- (a) Decide, in consultation with the manufacturer, that a new type approval is to be granted; or
- (b) Apply the procedure contained in paragraph 18.1.1. (Revision) and, if applicable, the procedure contained in paragraph 18.1.2. (Extension).

18.1.1. Revision

When particulars recorded in the information folder have changed and the Type Approval Authority considers that the modifications made are unlikely to have an appreciable adverse effect, and that in any case the vehicle still complies with the requirements, the modification shall be designated a "revision".

In such a case, the Type Approval Authority shall issue the revised pages of the information folder as necessary, marking each revised page to show clearly the nature of the modification and the date of re-issue. A consolidated, updated version of the information folder, accompanied by a detailed description of the modification, shall be deemed to meet this requirement.

18.1.2. Extension

The modification shall be designated an "extension" if, in addition to the change of the particulars recorded in the information folder,

- (a) Further inspections or tests are required; or
- (b) Any information on the communication document (with the exception of its attachments) has changed; or
- (c) Approval to a later series of amendments is requested after its entry into force.

18.2. Confirmation or refusal of approval, specifying the alterations, shall be communicated to the Parties to the Agreement which apply this Regulation by means of a form conforming to the model in Annex 4 to this Regulation. In addition, the index to the information package, attached to the communication document, shall be amended accordingly to show the date of the most recent revision or extension.

18.3. The Type Approval Authority issuing the extension of approval shall assign a series number to each communication form drawn up for such an extension.

19. Conformity of production

19.1. The conformity of production procedure shall comply with those set out in the Agreement, Schedule 1, (E/ECE/324-E/ECE/TRANS/505/Rev.3).

19.2. Every vehicle approved under this Regulation shall be so manufactured as to conform to the type approved by meeting the requirements set out in paragraph 15., where applicable paragraph 16. and paragraph 17. above.

20. Penalties for non-conformity of production

20.1. The approval granted in respect of a vehicle type pursuant to this Regulation may be withdrawn if the requirement laid down in paragraph 19.1. above is not complied with or if the vehicle fails to pass the checks prescribed in paragraph 19.2. above.

20.2. If a Party to the Agreement which applies this Regulation withdraws an approval it has previously granted, it shall forthwith so notify the other Contracting Parties applying this Regulation by means of a copy of the approval form bearing at the end, in

large letters, the signed and dated annotation "APPROVAL
WITHDRAWN".

21. Production definitively discontinued

If the holder of the approval completely ceases to manufacture a type of vehicle approved in accordance with this Regulation, he shall so inform the Type Approval Authority which granted the approval. Upon receiving the relevant communication, the Authority shall inform thereof the other Parties to the Agreement applying this Regulation by means of a copy of the approval form bearing at the end, in large letters, the signed and dated annotation "PRODUCTION DISCONTINUED".

22. Names and addresses of Technical Services responsible for conducting approval tests, and of Type Approval Authorities

The Parties to the Agreement applying this Regulation shall communicate to the United Nations Secretariat the names and addresses of the Technical Services responsible for conducting approval tests and of the Type Approval Authorities which grant approval and to which forms certifying approval or refusal or extension or withdrawal of approval, issued in other countries, are to be sent.

Annex 1

Information document for type approval of a device for means of front and lateral vision

The following information, if applicable, shall be supplied in triplicate and shall include a list of contents.

Any drawings shall be supplied in appropriate scale and in sufficient detail on size A4 paper or on a folder of A4 format.

Photographs, if any, shall show sufficient details.

1. Make (trade name of manufacturer):
2. Type and general commercial description(s):
3. Means of identification of the type, if indicated on the device:
4. Category of vehicle for which the device is intended:
5. Name and address of manufacturer:
6. Location and method of affixing of the approval mark for Close-proximity front and lateral side view mirrors:
- 6.1. Other mean of identification link to the approval mark for Close-proximity front and lateral side view mirrors:
7. Address(es) of assembly plant(s):
8. Mirrors (state for each mirror):
- 8.1. Variant
- 8.2. Drawing(s) for the identification of the mirror:
- 8.3. Details of the method of attachment:

Annex 2

Information document for type approval of vehicle with respect to the installation of means of front and lateral vision or detection

The following information, if applicable, shall be supplied in triplicate and include a list of contents.

Any drawings shall be supplied in appropriate scale and in sufficient detail on size A4 paper or on a folder of A4 format.

Photographs, if any, shall show sufficient details.

General

1. Make (trade name of manufacturer):.....
2. Type and general commercial description(s):
3. Means of identification of type, if marked on the vehicle:
4. Location of that marking:
5. Category of vehicle:
6. Name and address of manufacturer:.....
7. Address(es) of assembly plant(s):

General construction characteristics of the vehicle

8. Photograph(s) and/or drawing(s) of a representative vehicle:
9. Driving position: left/right¹
- 9.1. The vehicle is equipped to be driven in right-hand/left hand traffic¹
10. Range of vehicle dimensions (overall):.....
- 10.1 For chassis without bodywork
- 10.1.1. Width:³
- 10.1.1.1. Maximum permissible width:
- 10.1.1.2. Minimum permissible width:

³ "Overall width" of a vehicle means a dimension which is measured according to ISO standard 612-1978, term No. 6.2. In the case of vehicles of category other than M₁, in addition to the provisions of that standard, when measuring the vehicle width the following devices shall not be taken into account:

- (a) Customs sealing devices and their protection;
- (b) Devices for securing the tarpaulin and their protection;
- (c) Tyre failure tell-tale devices;
- (d) Protruding flexible parts of a spray-suppression system;
- (e) Lighting equipment;
- (f) For buses, access ramps in running order, lifting platforms and similar equipment in running order provided that they do not exceed 10 mm from the side of the vehicle and the corners of the ramps facing forwards or rearwards are rounded to a radius of not less than 5 mm; the edges shall be rounded to a radius of not less than 2.5 mm;
- (g) Devices for indirect vision;
- (h) Tyre-pressure indicators;
- (i) Retractable steps;
- (j) The deflected part of the tyre walls immediately above the point of contact with the ground.

- 10.1.2. Length:
- 10.1.2.1. Maximum permissible length:
- 10.1.2.2. Minimum permissible length:
- 10.1.3. Height:
- 10.1.3.1. Maximum permissible height:
- 10.1.3.2. Minimum permissible height:
- 10.2. For chassis with bodywork:
- 10.2.1. Width²
- 10.2.2. Length
- 10.2.3. Height
- 11. Bodywork
- 11.1. Means of front and lateral vision or detection: Direct vision, Devices approved to UN Regulation No. 46, Close-proximity front and lateral side view Mirror complying with this Regulation, Front and lateral side view camera system complying with this Regulation, Detection System complying with this Regulation⁴.
- 11.1.1. Direct vision,
- 11.1.1.1. Drawing(s)/photograph(s) showing the direct vision relative to the vehicle structure:
- 11.1.2. Devices approved to UN Regulation No. 46,
- 11.1.2.1. Type approval number(s) of the device(s) approved according UN Regulation No. 46
- 11.1.2.2. Class(es) of mirrors and devices for indirect vision (I, II, III, IV, V, VI)²
- 11.1.2.3. Drawing(s) showing the position(s) of the device(s) relative to the vehicle structure:
- 11.1.3. Close-proximity front and lateral view Mirror complying with this Regulation,
- 11.1.3.1. Drawing(s) showing the position(s) of the mirror relative to the vehicle structure:
- 11.1.3.2. Details of the method(s) of attachment including that part of the vehicle structure to which it is attached:
- 11.1.3.3. Optional equipment which may affect the front and lateral field of vision:
- 11.1.3.4. A brief description of the electronic components (if any) of the adjustment device:
- 11.1.4. Front and lateral view camera system complying with this Regulation.

⁴ Strike out what does not apply.

-
- 11.1.4.1. Drawing(s)/photograph(s) showing the position(s) of the camera(s) relative to the vehicle structure:
 - 11.1.4.2. Drawing(s)/photograph(s) showing the arrangement of the monitor(s) including surrounding interior parts:
 - 11.1.4.3. Drawing(s)/photograph(s) showing the drivers view onto the monitor(s):
 - 11.1.4.4. Drawing(s)/photograph(s) showing the setup and monitor image of the required field of view:
 - 11.1.4.5. Details of the method(s) of attachment of the Front and lateral view camera system including that part of the vehicle structure to which it is attached:
 - 11.1.4.6. Optional equipment which may affect the front and lateral field of vision:
 - 11.1.4.7. A brief description of the electronic components (if any) of the adjustment device:
 - 11.1.4.8. A technical specification and operator's manual of the Front and lateral side view camera system:
 - 11.1.5. Detection System complying with this Regulation.
 - 11.1.5.1. Drawing(s)/photograph(s) showing the position(s) of the sensor(s) relative to the vehicle structure:
 - 11.1.5.2. Information signal: acoustic, optical, haptics .
 - 11.1.5.3. A technical specification and operator's manual of the detection System:
 12. Device(s) that are presented for approval to this regulation:

Annex 3

Communication

(Maximum format: A4 (210 x 297 mm))



issued by:

Name of administration:

.....

5

Concerning:⁶

- Approval granted
- Approval extended
- Approval refused
- Approval withdrawn
- Production definitively discontinued

of a type of device (Separate Technical Unit) for means of front and lateral vision pursuant to UN Regulation No. [xxx].

Approval No. Extension No.

1. Trade name or mark of device:
2. Manufacturer's name for the type of device:
3. Manufacturer's name and address:
4. If applicable, name and address of manufacturer's representative:
5. Submitted for approval on:
6. Technical Service responsible for conducting approval tests:
7. Date of report issued by that Service
8. Number of report issued by that Service
9. Brief description
- Identification of the device: mirror, Front and lateral view camera system, other device²
- Device for Close-proximity front and lateral side view²
10. Position of the approval mark:
11. Reason(s) for extension (if applicable):
12. Approval granted/refused/extended/withdrawn:²
13. Place:
14. Date:
15. Signature:

¹ Distinguishing number of the country which has granted/extended/refused/withdrawn approval (see approval provisions in the Regulations).

² Strike out what does not apply.

-
16. The list of documents deposited with the Type Approval Authority which has granted approval is annexed to this communication and may be obtained on request.

Annex 4

Communication

(Maximum format: A4 (210 x 297 mm))



issued by :

Name of administration:

.....
.....
.....

7

Concerning:⁸

- Approval granted
- Approval extended
- Approval refused
- Approval withdrawn
- Production definitively discontinued

of a type of vehicle with regard to the means of front and lateral vision or detection pursuant to UN Regulation No. [xxx].

Approval number: Extension No.:

1. Make (trade name of manufacturer):
2. Type and general commercial description(s).....
3. Means of identification of type, if marked on the vehicle:.....
- 3.1. Location of that marking:
4. Category of vehicle: (M₁, N₁)²
5. Name and address of manufacturer:
6. Address(es) of the production plant(s)
7. Additional information: (where applicable). See appendix
8. Technical Service responsible for carrying out the tests:
9. Date of test report:
10. Number of test report:.....
11. Remarks: (if any). See appendix
12. Place:.....
13. Date:.....
14. Signature:.....
15. The index to the information package lodged with the Type Approval Authority, which may be obtained on request is attached.

¹ Distinguishing number of the country which has granted/extended/refused/withdrawn approval (see approval provisions in the Regulation).

² Strike out what does not apply.

Annex 4 – Appendix

Appendix to type approval communication form No. concerning the type approval of a vehicle with regard to the means of front and lateral vision or detection pursuant to UN Regulation No. [xxx].

1. Trade name or mark of means of front and lateral vision or detection and component type-approval number (if applicable):
2. Means of front and lateral vision or detection: Direct vision, Devices approved to UN Regulation No. 46, Close-proximity front and lateral view Mirror complying with this Regulation, Front and lateral view camera system complying with this Regulation, Detection System complying with this Regulation¹.
3. Extension of type approval of the vehicle to cover the following means of front and lateral vision or detection
4. Data for identification of the R point of the driver's seating position: ..
5. Maximum and minimum bodywork width, length and height in respect of which the means of front and lateral vision or detection have been granted type-approval
6. The following documents, bearing the type approval number shown above, are annexed to this certificate (if applicable):
- (a) Drawings showing the mounting(s) of the devices for means of front and lateral vision or detection.....
- (b) Drawings and plans showing the mounting position(s) and characteristics of the part of the structure where the devices for means of front and lateral vision or detection are mounted..
- (c) Drawings and plans showing the visual obstructions which affect the front and lateral vision, e.g. the interior fittings, glazing, etc.
7. Remarks: (e.g. valid for right hand/left hand traffic¹)

Annex 5

Arrangement of approval mark of a device for means of front and lateral vision

(See paragraph 5.4. of the Regulation)

$a = 5$ millimetre min.

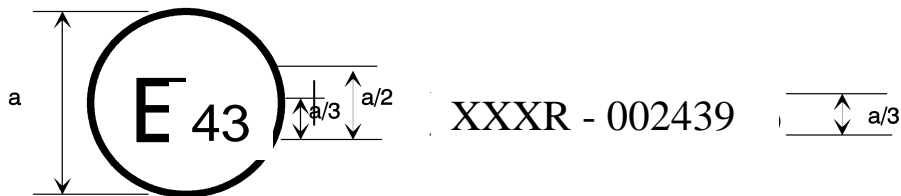

The above approval mark affixed to a device for means of front and lateral vision indicates that the device is a main Close-proximity front and lateral view device, which has been approved in Japan (E 43) pursuant to UN Regulation No. [xxx] and under approval number 002439. The first two digits of the approval number indicate that the approval was granted in accordance with the requirements of UN Regulation No. [xxx] in its original form.

Note: The approval number and the additional symbol shall be placed close to the circle and either above or below the "E" or to the left or right of that letter. The digits of the approval number shall be on the same side of the "E" and point in the same direction. The additional symbol shall be directly opposite the approval number. The use of Roman numerals as approval numbers shall be avoided so as to prevent any confusion with other symbols.

Annex 6

Test method for determining reflectivity

1. Definitions
 - 1.1. CIE standard illuminate A:⁹ Colorimetric illuminate, respecting the full radiator at $T_{68} = 2,855.6$ K.
 - 1.1.2. CIE standard source A¹: Gas-filled tungsten filament lamp operating at a correlated colour temperature of $T_{68} = 2,855.6$ K.
 - 1.1.3. CIE 1931 standard colorimetric observer¹: Receptor of radiation whose colorimetric characteristics correspond $\bar{x}(\lambda)$, $\bar{y}(\lambda)$, $\bar{z}(\lambda)$ to the spectral tristimulus values (see table).
 - 1.1.4. CIE spectral tristimulus values¹: Tristimulus values of the spectral components of an equi energy spectrum in the CIE (XYZ) system.
 - 1.1.5. Photopic vision:¹ Vision by the normal eye when it is adapted to levels of luminance of at least several cd/m^2 .
 2. Apparatus
 - 2.1. General

The apparatus shall consist of a light source, a holder for the test sample, a receiver unit with a photodetector and an indicating meter (see Figure 1), and means of eliminating the effects of extraneous light.

The receiver may incorporate a light-integrating sphere to facilitate measuring the reflectance of non-flat (convex) mirrors (see Figure 2).
 - 2.2. Spectral characteristics of light source and receiver

The light source shall consist of a CIE standard source A and associated optics to provide a near-collimated light beam. A voltage stabiliser is recommended in order to maintain a fixed lamp voltage during instrument operation.

The receiver shall have a photodetector with a spectral response proportional to the photopic luminosity function of the CIE (1931) standard colorimetric observer (see table). Any other combination of illuminate-filter-receptor giving the overall equivalent of CIE standard illuminate A and photopic vision may be used. When an integrating sphere is used in the receiver, the interior surface of the sphere shall be coated with a matt (diffusive) spectrally non-selective white coating.
 - 2.3. Geometrical conditions

⁹ Definitions taken from CIE publication 50 (45), International Electrotechnical Vocabulary, Group 45, Lighting

The angle of the incident beam (Θ) should preferably be 0.44 ± 0.09 rad ($25 \pm 5^\circ$) from the perpendicular to the test surface and shall not exceed the upper limit of the tolerance (i.e. 0.53 rad or 30°). The axis of the receptor shall make an angle (Θ) with this perpendicular equal to that of the incident beam (see Figure 1). The incident beam upon arrival at the test surface shall have a diameter of not less than 13 mm (0.5 inch). The reflected beam shall not be wider than the sensitive area of the photodetector, shall not cover less than 50 per cent of such area, and as nearly as possible shall cover the same area segment as used during instrument calibration.

When an integrating sphere is used in the receiver section, the sphere shall have a minimum diameter of 127 mm (5 inch). The sample and incident beam apertures in the sphere wall shall be of such a size as to admit the entire incident and reflected light beams. The photodetector shall be so located as not to receive direct light from either the incident or the reflected beam.

2.4. Electrical characteristics of the photodetector-indicator unit

The photodetector output as read on the indicating meter shall be a linear function of the light intensity of the photosensitive area. Means (electrical and/or optical) shall be provided to facilitate zeroing and calibration adjustments. Such means shall not affect the linearity or the spectral characteristics of the instrument. The accuracy of the receptor indicator unit shall be within ± 2 per cent of full scale, or ± 10 per cent of the magnitude of the reading, whichever is the smaller.

2.5. Sample holder

The mechanism shall be capable of locating the test sample so that the axes of the source arm and receptor intersect at the reflecting surface. The reflecting surface may lie within or at either face of the mirror sample, depending on whether it is a first surface, second surface or prismatic "flip" type mirror.

3. Procedure

3.1. Direct calibration method

In the direct calibration method, air is used as the reference standard. This method is applicable for those instruments, which are so constructed as to permit calibration at the 100 per cent point by swinging the receiver to a position directly on the axis of the light source (see Figure 1).

It may be desired in some cases (such as when measuring low-reflectivity surfaces) to use an intermediate calibration point (between 0 and 100 per cent on the scale) with this method. In these cases, a neutral density filter of known transmittance shall be inserted in the optical path, and the calibration control shall then be adjusted until the meter reads the percentage transmission

of the neutral density filter. This filter shall be removed before reflectivity measurements are performed.

3.2. Indirect calibration method

The indirect calibration method is applicable in the case of instruments with fixed source and receiver geometry. A properly calibrated and maintained reflectance standard is required. This reference standard should preferably be a flat mirror with a reflectance value as near as possible to that of the test samples.

3.3. Flat mirror measurement

The reflectance of flat mirror samples can be measured on instruments employing either the direct or the indirect calibration method. The reflectance value is read directly from the indicating meter.

3.4. Non-flat (convex) mirror measurement

Measurement of the reflectance of non-flat (convex) mirrors requires the use of instruments which incorporate an integrating sphere in the receiver unit (see Figure 2). If the instrument-indicating meter indicates n_e divisions with a standard mirror of E per cent reflectance, then, with a mirror of unknown reflectance, n_x divisions will correspond to a reflectance of X per cent, in accordance with the formula:

$$X = E \frac{n_x}{n_e}$$

Figure 1
Generalised reflectometer showing experimental set-ups for the two calibration methods

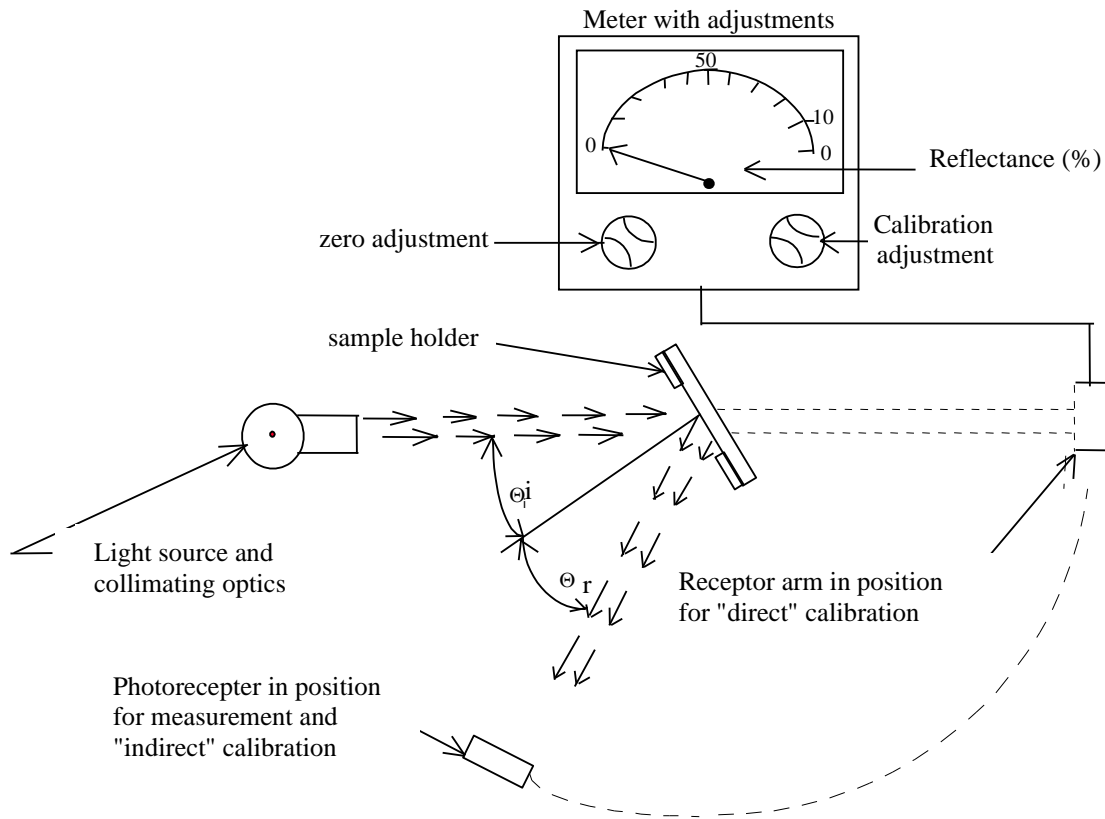
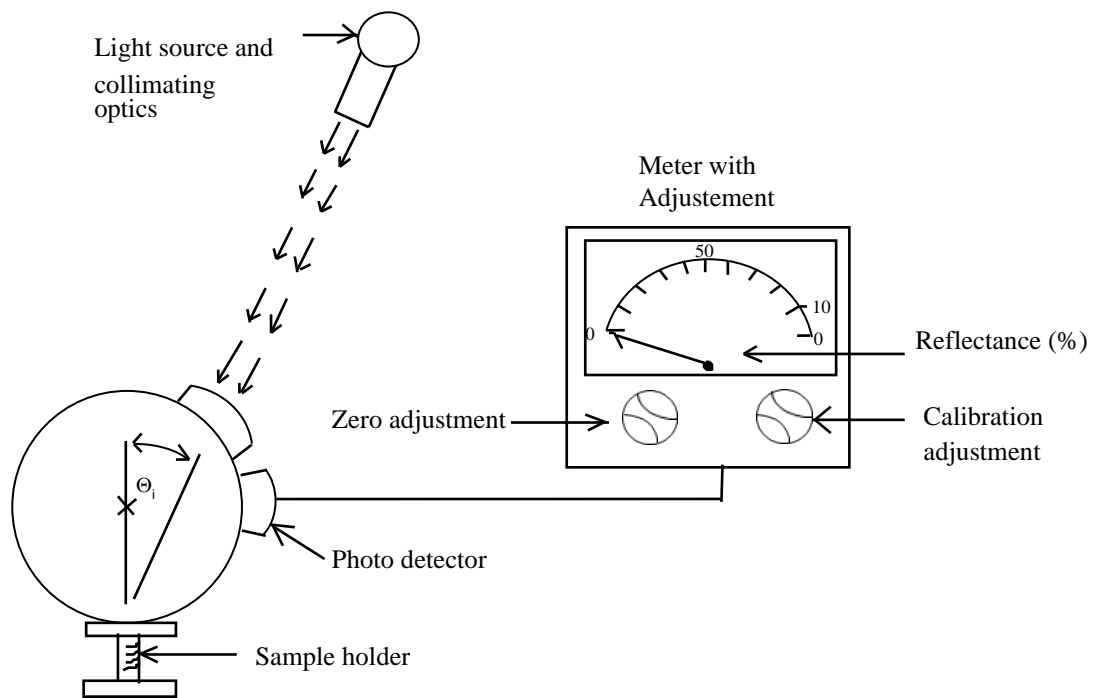

Figure 2
Generalised reflectometer, incorporating an integrating sphere in the receiver



4. Spectral tristimulus values for the CIE 1931 standard colorimetric observer¹⁰

This table is taken from CIE publication 50 (45) (1970)

λ nm	$\bar{x}(\lambda)$	$\bar{y}(\lambda)$	$\bar{z}(\lambda)$
380	0.001 4	0.000 0	0.006 5
390	0.004 2	0.000 1	0.020 1
400	0.014 3	0.000 4	0.067 9
410	0.043 5	0.001 2	0.207 4
420	0.134 4	0.004 0	0.645 6
430	0.283 9	0.011 6	1.385 6
440	0.348 3	0.023 0	1.747 1
450	0.336 2	0.038 0	1.772 1
460	0.290 8	0.060 0	1.669 2
470	0.195 4	0.091 0	1.287 6
480	0.095 6	0.139 0	0.813 0
490	0.032 0	0.208 0	0.465 2
500	0.004 9	0.323 0	0.272 0
510	0.009 3	0.503 0	0.158 2
520	0.063 3	0.710 0	0.078 2
530	0.165 5	0.862 0	0.042 2
540	0.290 4	0.954 0	0.020 3
550	0.433 4	0.995 0	0.008 7
560	0.594 5	0.995 0	0.003 9
570	0.762 1	0.952 0	0.002 1
580	0,916 3	0.870 0	0.001 7
590	1.026 3	0.757 0	0.001 1
600	1.062 2	0.631 0	0.000 8
610	1.002 6	0.503 0	0.000 3
620	0.854,4	0.381 0	0.000 2
630	0.642 4	0.265 0	0.000 0
640	0.447 9	0.175 0	0.000 0
650	0.283 5	0,107 0	0.000 0
660	0.164 9	0.061 0	0.000 0
670	0.087 4	0,032 0	0.000 0
680	0.046 8	0.017 0	0.000 0
690	0.22 7	0,008 2	0.000 0
700	0.011 4	0.004 1	0.000 0
710	0.005 8	0.002 1	0.000 0
720	0.02 9	0.001 0	0.000 0
730	0.001 4	0.000 5	0.000 0
740	0.000 7	0.000 2 (*)	0.000 0
750	0.000 3	0.000 1	0.000 0
760	0.000 2	0.000 1	0.000 0
770	0.000 1	0.000 0	0.000 0
780	0.000 0	0.000 0	0.000 0

(*) Changed in 1966 (from 3 to 2)

¹⁰ Abridged table. The values of $\bar{y}(\lambda) = V(\lambda)$ are rounded off to four decimal places

Explanatory figure

Example of device for measuring the reflection factor of spherical mirrors

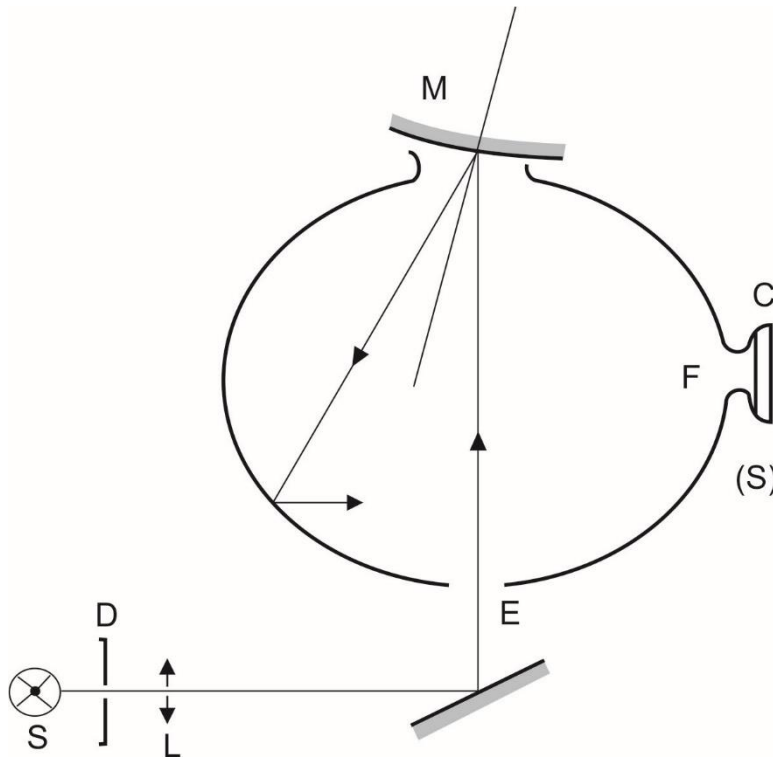

- C = Receiver
- D = Diaphragm
- E = Window of entry
- F = Window of measurement
- L = Lens
- M = Object window
- S = Light source
- (S) = Integrating sphere

Annex 7

Procedure for determining the radius of curvature "r" of the reflecting surface of a mirror

1. Measurement
 - 1.1. Equipment

A "spherometer" similar to the one described in Figure 1 of this annex having the indicated distances between the tracing pin of the dial gauge and the fixed legs of the bar is used.
 - 1.2. Measuring points
 - 1.2.1. The principal radii of curvature shall be measured at three points situated as close as possible to positions at one-third, one-half and two-thirds of the distance along the arc of the reflecting surface passing through the centre of this surface and parallel to segment b, or of the arc passing through the centre of the reflecting surface which is perpendicular to it if this arc is the longer.
 - 1.2.2. Where, owing to the size of the reflecting surface, it is impossible to obtain measurements in the directions defined in paragraph 2.1.2.2.2. of this Regulation, the Technical Services responsible for the tests may take measurements at the said point in two perpendicular directions as close as possible to those prescribed above.
2. Calculation of the radius of curvature "r"

"r" expressed in mm is calculated from the formula:

$$r = \frac{r_p1 + r_p2 + r_p3}{3}$$

Where:

- r_p1 = the radius of curvature at the first measuring point,
- r_p2 = the radius of curvature at the second measuring point,
- r_p3 = the radius of curvature at the third measuring point.

Figure 1
Spherometer

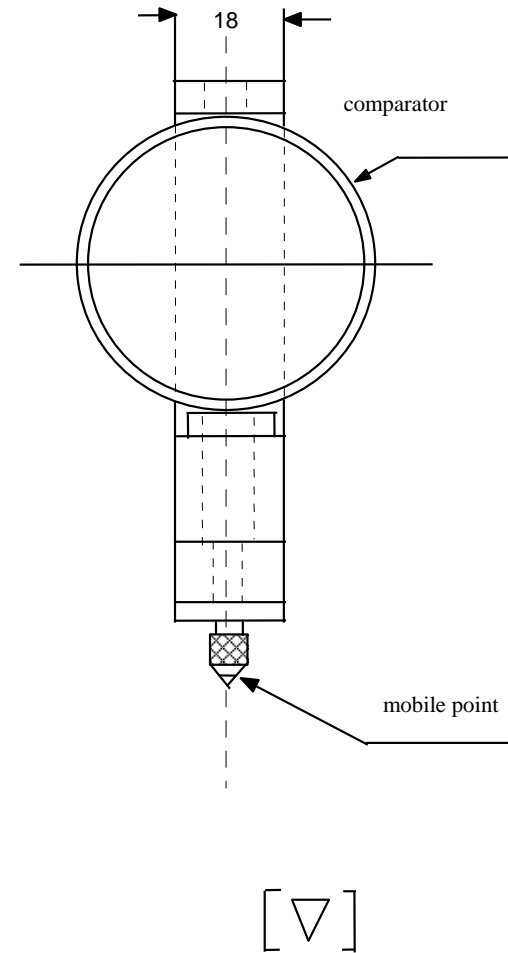
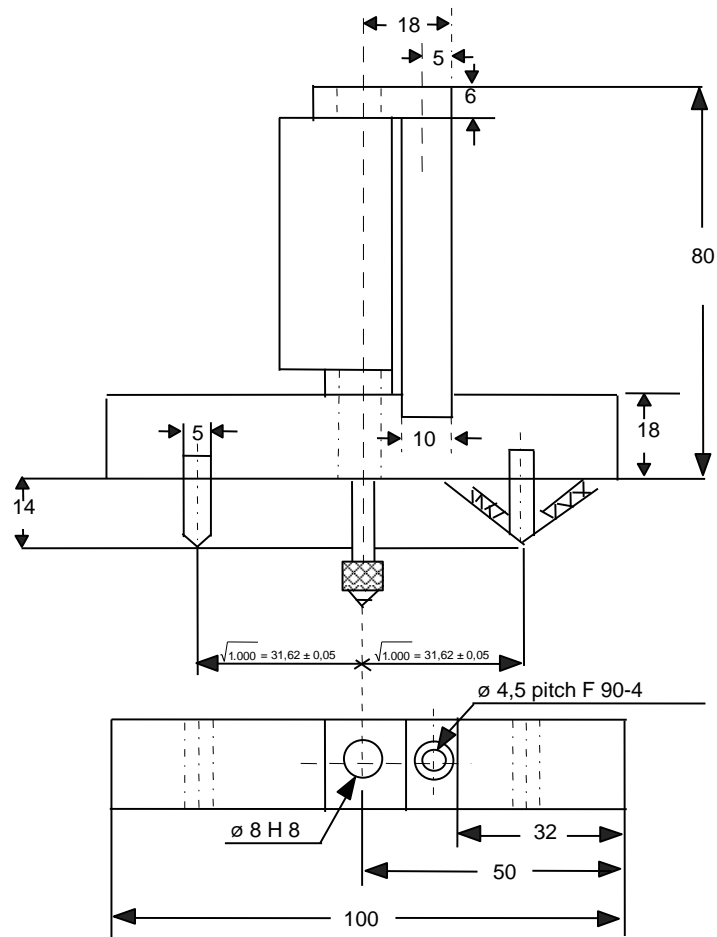

(all dimensions in millimetres)

Annex 8

Procedure for determining the "H" point and the actual torso angle for seating positions in motor vehicles¹

Appendix 1 - Description of the three dimensional "H" point machine (3-D H machine)¹

Appendix 2 - Three-dimensional reference system¹

Appendix 3 - Reference data concerning seating positions¹¹

¹¹ The procedure is described in Annex 1 to the Consolidated Resolution on the Construction of Vehicles (R.E.3) (document ECE/TRANS/WP.29/78/Rev.4).
www.unece.org/trans/main/wp29/wp29wgs/wp29gen/wp29resolutions.html

Annex 9

Test methods for Close-proximity front and lateral field of vision

This methods shall be applied in the area that is designated by the manufacturer as covering direct or indirect (mirrors or FLCVS) means.

1. Field of vision

The requirements of field of vision defined in paragraphs 15.2. of this Regulation can be tested under the conditions described in this Annex.

1.1. Test objects

Each test object shall be a right circular cylinder that is 1.0 m high and 0.3 m in external diameter.

Figure A
Test object

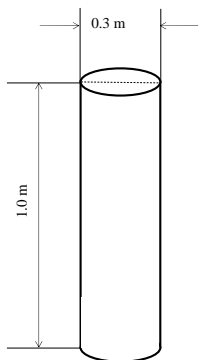

1.2. Test object locations and orientations

The test object shall be in contact with the vehicle's front and lateral side from at the centre of passenger side mirror to driver's side mirror shall be seen in the close-proximity front and lateral side view field of vision. In the case of the vehicle that equipped with CMS that comply UN Regulation No. 46, 04 Series of amendments, the manufacturer shall consider the same vehicle equipped with side mirrors or to use centre of Class II CMS camera lens instead of the centre of the side mirror.

Figure B
Test object locations

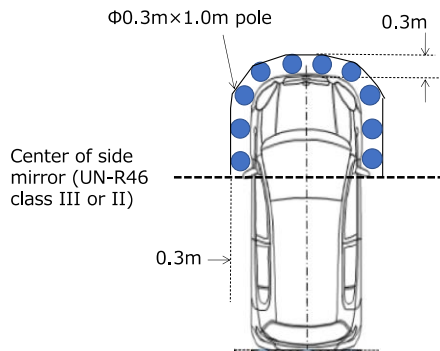

1.3 Test conditions

1.3.1. Lighting condition for camera systems (FLCVS).

The ambient illumination conditions in which testing is conducted consists of light that is evenly distributed from above and is at an intensity of between 7,000 lux and 10,000 lux, as measured at the centre of the exterior surface of the vehicle's roof.

At the request of the manufacturer, the test may be carried out at lower ambient illumination intensity conditions.

1.3.2. Temperature for camera systems (FLCVS).

The temperature inside the vehicle during the test shall be ~~is~~ any temperature between 15 deg. C and 25 deg. C.

1.3.3. Vehicle conditions.

1.3.3.1 Tyres.

The vehicle's tyres shall be set to the vehicle manufacturer's recommended cold inflation pressure.

1.3.3.2. Vehicle load.

The vehicle is in running order as defined in the consolidated Resolution on the Construction of vehicles (R.E.3) (ECE/TRANS/WP.29/78/Rev.6, paragraph 2.2.5.4. , plus for M1 and N1 vehicles one front seat passenger (75 kg).

1.3.3.3. Adjustable suspension

If the vehicle is equipped with adjustable suspension system, it shall be set at worst condition.

1.4. Test procedure

The vision of each pole shall be tested by sweeping through the pole in contact with the vehicle's front and side from at the centre of passenger side mirror to driver's side mirror.

Annex 10

Adjustment Methods for driver's ocular points

1. Back angle compensation

In testing according to paragraph 15.2.1.1., driver's ocular points, or the ocular reference point shall be adjusted in the forward/rearward or upward/downward direction by a specific compensation distance defined according to the respective back angle of the test vehicle, as shown in Table 1.

Table 1:
Back angle compensation

<i>Back angle</i> [°]	<i>Compensation distance</i>		<i>Back angle</i> [°]	<i>Compensation distance</i>	
	<i>Forward/rearward</i> [mm]	<i>Upward/downward</i> [mm]		<i>Forward/rearward</i> [mm]	<i>Upward/downward</i> [mm]
5	-186	28	23	-18	5
6	-177	27	24	-9	3
7	-167	27	25	0	0
8	-157	27	26	9	-3
9	-147	26	27	17	-5
10	-137	25	28	26	-8
11	-128	24	29	34	-11
12	-118	23	30	43	-14
13	-109	22	31	51	-18
14	-99	21	32	59	-21
15	-90	20	33	67	-24
16	-81	18	34	76	-28
17	-72	17	35	84	-32
18	-62	15	36	92	-35
19	-53	13	37	100	-39
20	-44	11	38	108	-43
21	-35	9	39	115	-48
22	-26	7	40	123	-52

Note: Symbols used in the table: Forward/rearward direction (-: forward, +: rearward); Upward/downward direction (-: downward, +: upward)

2. Movable range compensation

In testing according to paragraph 15.2.1.1., as compensation of the driver's ocular points (binocular) or the ocular reference point of the driver moving the body in forward/rearward, lateral, or upward/downward directions to check the vehicle's surroundings at the start of the vehicle, measurements may be taken with the driver's ocular points adjusted in the forward/rearward, lateral, or upward/downward directions, respectively, based on the reference driver's ocular points or the ocular reference point, provided that

it is within the range of compensation distances listed in each column of Table 2.

Adjusted driver's ocular points or the ocular reference point shall be located in a three-dimensional space consisting of four points as follows, the driver's ocular point defined in 12.1. or the ocular reference point defined in 12.2 of this regulation and driver's ocular points or the ocular reference point compensation for the stretching defined in table 2.

Table 2:
Range of driver's ocular points compensation for the stretching

<i>Measures in [mm]</i>	<i>Forward/rearward compensation distance (+: rearward, -: forward)</i>	<i>Lateral compensation distance (+: right, -: left)</i>	<i>Upward/downward compensation distance (+: upward, -: downward)</i>
Upward stretching ocular points	0	-10	40
Forward stretching ocular points	-140	-15	10
Lateral stretching ocular points	30	-110	15

Note: In the table, for the left-hand drive vehicles, "right" shall be read as "left", and "left" shall be read as "right".

3. Looking out compensation for the driver's side

In testing according to paragraph 15.2.1.1., as compensation of the driver's ocular points (binocular) or the ocular reference point of the driver moving the body for looking out from side window to check vulnerable road users around the front side corner, measurements may be taken with the driver's ocular points or the ocular reference point adjusted in the forward/rearward, lateral, or upward/downward directions, respectively, based on the reference driver's ocular points, provided that it is within the range of compensation distances listed in each column of Table 3.

Adjusted driver's ocular points or the ocular reference point shall be located in a three-dimensional space consisting of four points as follows, the driver's ocular points defined in 12.1. or the ocular reference point defined in 12.2 of this regulation and driver's ocular points or the ocular reference point compensation for the stretching defined in table 3.

Table 3:
Range of driver's ocular points compensation for the stretching

<i>Measures in [mm]</i>	<i>Forward/rearward compensation distance (+: rearward, -: forward)</i>	<i>Lateral compensation distance (+: right, -: left)</i>	<i>Upward/downward compensation distance (+: upward, -: downward)</i>
Looking out with stretching upward side of the driver	-100	300	0
Looking out with stretching forward side of the driver	-200	250	-50
Looking out as much as possible for outer side of the driver	-50	350	-50

Note: In the table, for the left-hand drive vehicles, "right" shall be read as "left", and "left" shall be read as "right".

Annex 11

Range of Blind Area Created by the A-Pillar or Exterior Rear-View Mirror

1. Definitions
 - 1.1. "*Blind area created by the exterior rear-view mirror*" means a blind area created by the vehicle structure that retains or protects the exterior rear-view mirror and exterior rear-view mirror.
 - 1.2. "*Blind area created by the A-pillar*" means a blind area created by the vehicle structure that is located forward of the ocular reference point and above a plane parallel to the vehicle centre and passing through the two points consisting of the the ocular reference point and the lowermost point of the side glazing's transparent area where the ground surface can be viewed through the side glazing when the left side of the vehicle is checked from the ocular reference point (point a) (Figure A). However, a window provided in a part of the lower area of the door is not considered as the side glazing.

For the left-hand drive vehicles, "left" shall be read as "right".

2. Range of the blind area

The range of the blind area created by the A-pillar or exterior rear-view mirror shall be an area that meets the following formula. In this case, if there are more than one blind area, each blind area shall meet the conditions of the formulae.

$$X \leq 0.292 \cdot L - 0.203$$

Where:

- X (m): is the limit of the excluded area, i.e. the distance between the centre of a cylinder in contact with the front edge of the blind area and the centre of a cylinder in contact with its rear edge.
- L (m): is located inside the blind area created by the A-pillar or exterior rear-view mirror. Distance between the rear edge of a cylinder in contact with the rear edge of the blind area and the front edge of the rear wheel.

Figure A (right-handed drive case)

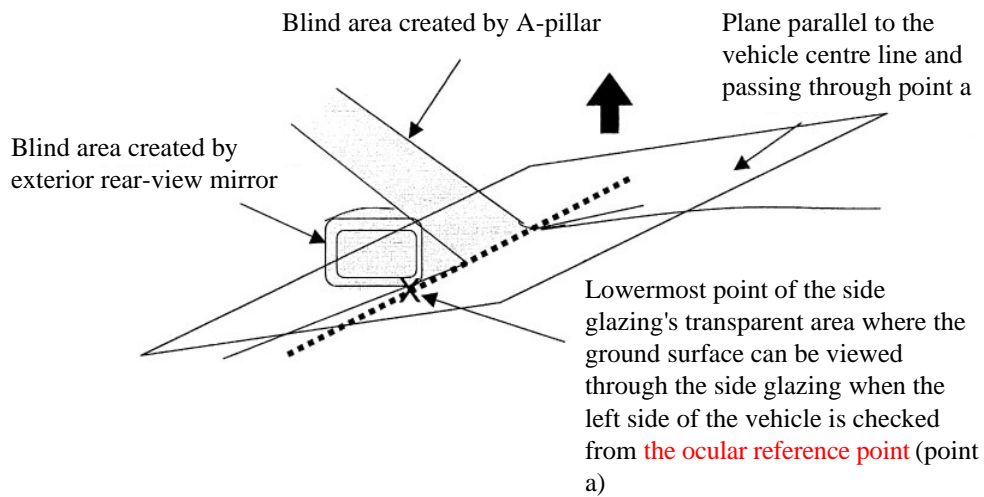
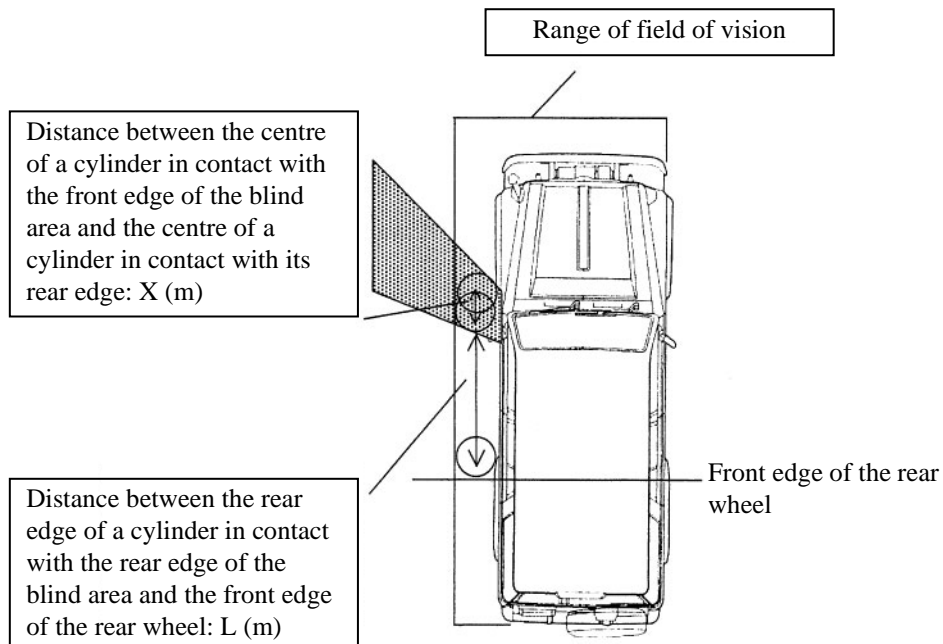

Figure B (right-handed drive case)



Test Methods for Detection Systems

1. Front and lateral horizontal area detection

Detection system shall fulfil the test as specified in paragraph 1.3.1. in this Annex.
- 1.1. Test conditions

The test object shall be as per paragraph 7.1. of ISO 17386:2010. During testing, the wind speed shall not exceed 1 m/s. The temperature shall be 20 ± 5 °C and the humidity shall be 60 ± 25 percent. There shall be no rain or snow. The test shall be performed on a flat, dry asphalt or concrete surface. The test shall not be affected by the reflection of sound waves or electromagnetic waves from any walls, auxiliary testing equipment or any other objects in the environment.
- 1.2. Test preparation

One test object shall be used. The positions of the test object are selected by the manufacturer to ensure the detection of the test object. The test object shall be located in the detectable grids within the front and lateral horizontal area in 1.3.1. of this annex. The test vehicle in the initial state shall be in the parking condition. Here, the parking condition means that the steering is in the neutral position and the P (park) position is selected in the case of vehicles equipped with automatic transmissions, whereas it means the neutral gear being selected and the parking brake being engaged in the case of vehicles equipped with manual transmissions.

When testing, a person (of 75 kg in weight) shall sit in the driver's seat and, keeping the vehicle in the stationary condition, perform an operation that activates the detection system as described by the manufacturer or in the owner's manual.
- 1.3. Test method
 - 1.3.1. Field of detection

The field of detection shall be divided into three areas: front, corners, and sides. The test methods for the front, corners, and sides shall be specified in paragraphs 1.3.1.1, 1.3.1.2, and 1.3.1.3.

The test shall be conducted with the test object in the field of detection and shall be conducted until the first grid that exceeds the field of detection (See Figure A).

The test shall be conducted with test objects installed at intervals of 100 mm, but for the purpose of reducing the number of measurements, the test may be conducted with the test objects installed at intervals of 200 mm, and if there is an undetected grid, the test shall be conducted for both neighbouring grids.

For overlapping areas between the grid of test points specified in paragraph 1.3.1.2 and the grid of test points specified in paragraph 1.3.1.1 or 1.3.1.3, either method can be used.

Figure A

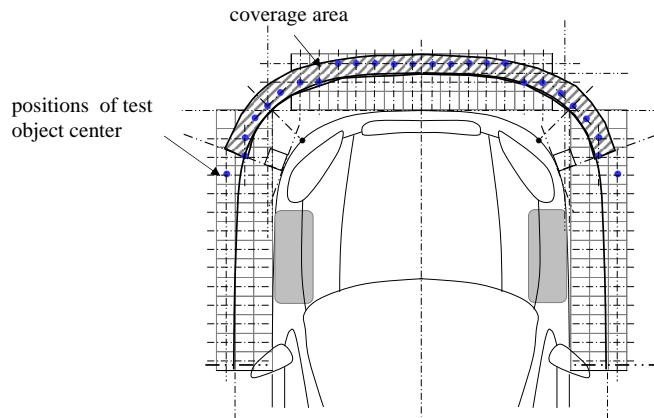

1.3.1.1. Field of detection of front area

The field of detection of the front area is shown in Figure B.

W_f is equal to the vehicle width measured along the front axle.

W_{test} is equal to half of W_f rounded to the nearest 100 mm and then multiplied by two.

Set a front area of W_{test} in the vehicle width direction and 300 mm in the vehicle forward direction, symmetrically around the vehicle centre axis based on the front end of the vehicle and draw a 100 mm x 100 mm grid on the floor of the area.

Draw a curve that follow the shape of the vehicle contour (vertical projection on the ground as shown in Figure B) between the two constructed vehicle corners. The curve shall be set at 200mm forward of the vehicle contour. For the part outside of the constructed vehicle corners, the curve is completed by straight sections perpendicular to the vehicle centre axis to cover the whole vehicle width(W_{test}). For the construction of corners see paragraph 1.3.2.1. below. Place the test object centre on the grid intersection which is nearest and in the forward direction of the curve, in each grid row parallel to the vehicle centre axis.

The first curve shall follow the front bumper shape in the top view of the vehicle for the part between the two virtual corners of the vehicle but shall be a straight line orthogonal to the forward direction for the part outside the virtual corners.

Figure B

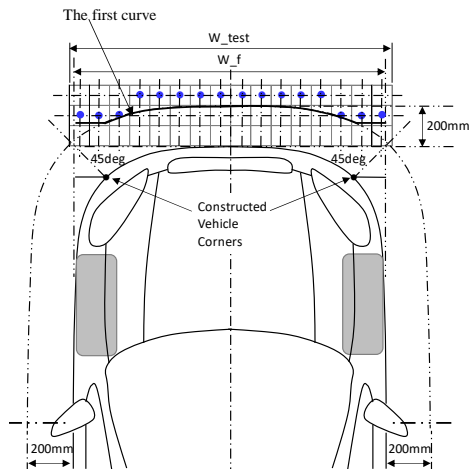

1.3.1.2. Field of detection of corner areas

The field of detection of the corner areas is shown in Figure C.

- (a) Draw a rectangular box close to the vehicle contours.
- (b) Draw a line from each corner of the box to the vehicle at an angle of 45 degrees.
- (c) The intersections of these lines and the vehicle contours are defined as the vehicle corners.
- (d) Test each of the test objects placed at the following points: one 250 mm away from one vehicle corner along a line that rises at a 45-degree angle, and two others, each 100 mm away from the said point on both sides along a line that orthogonally crosses the said 45-degree line. Repeat the same for the other corner.

Figure C

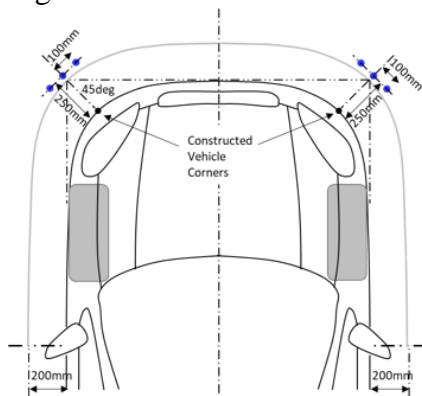

1.3.1.3. Field of detection of side areas

The field of detection of the side areas is shown in Figure D.

L_f is equal to the distance from the centre of the side mirror to the front end of the vehicle, measured parallel to the vehicle centre axis.

L_{test} is the value of L_f rounded to the nearest 100 mm.

Set a rectangular side area of L_{test} in the front-rear direction and 300 mm in the vehicle width direction, parallel to and symmetrical around the vehicle centre axis based on the front end of the vehicle and draw a 100 mm x 100 mm grid on the floor of the area.

Draw a curve that follow the shape of the vehicle contour (vertical projection on the ground as shown in Figure B) between the two constructed vehicle corners. The curve has a distance of 200mm to the vehicle contour. For the part outside of the constructed vehicle corners, the curve is completed by straight sections perpendicular to the vehicle centre axis to cover the whole vehicle width(W_{test}). For the construction of corners see paragraph 1.3.2.1. below.

Place the test object centre on the grid intersection which is nearest and in the forward direction of the curve, in each grid row parallel to the vehicle centre axis.

The first curve shall be a straight line parallel to the forward direction for the part in front of the virtual corners, while the part behind the virtual corners shall follow the shapes of the vehicle sides and front bumper in the top view of the vehicle.

Figure D

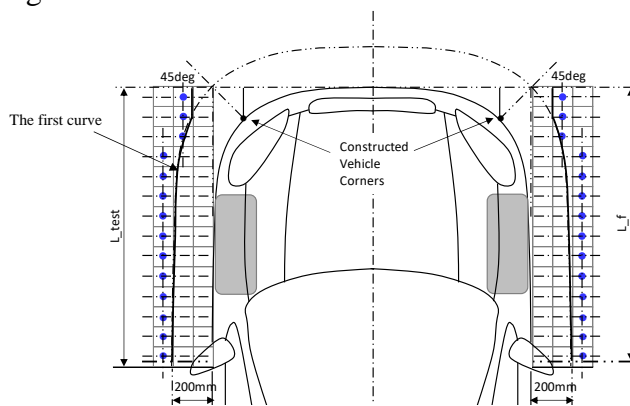

1.3.2. Detection test

In the field of detection, there shall be no more than two consecutive undetected grids.

When the warning is provided for more than 5 seconds continuously, it is judged that the test object is detected. The detection test shall be performed 1 time for each test object. However, if necessary, according to the agreement of the Technical Service and manufacturer, it can be judged that the test object is detected in case warnings are provided in 4 out of 5 tests.