

# GTR9-8-03r1

## GTR9 – Draft Working Document of IG GTR9 PH2

Version 2, 10 Sept. 2013

| Current GTR9 Text (consolidated version, status 09/2013)   | Proposed amendments |
|--|---------------------|
| 1. PURPOSE<br><br>1.1. The purpose of this global technical regulation is to bring about an improvement in the construction of certain parts of the front of vehicles which have been identified as causing injury when in collision with a pedestrian or other vulnerable road user.  |                     |
| 1.2. The vehicles to be tested under the regulation are representative of the majority of vehicles in circulation in the urban environment, where there is a greater potential for collision with pedestrians and other vulnerable road users, and include passenger cars, vans and light trucks.  |                     |
| 2. APPLICATION / SCOPE<br><br>2.1. This global technical regulation (gtr) shall apply to the frontal surfaces of power driven vehicles of category 1-1 with a gross vehicle mass exceeding 500 kg; and of category 1-2 with a gross vehicle mass exceeding 500 kg but not exceeding 4,500 kg; and of category 2 with a gross vehicle mass exceeding 500 kg but not exceeding 4,500 kg. <sup>1</sup> However, power driven vehicles of category 1-2 and category 2, where the distance, measured longitudinally on a horizontal plane, between the transverse centre line of the front axle and the R-point of the driver's seat is less than 1,100 |                     |

<sup>1</sup> A contracting party may restrict application of the requirements in its domestic legislation if it decides that such restriction is appropriate.

|   |  |
|---|--|
| <p>mm, are exempt from the requirements of this regulation. Contracting Parties can exempt category 1-1 vehicles where the distance, measured longitudinally on a horizontal plane, between the transverse centre line of the front axle and the R-point of the driver's seat is less than 1,100 mm and having the components of the frontal structure that are interchangeable with the above-mentioned category 1-2 and category 2 vehicles.</p> <p>All definitions of Special Resolution No. 1 shall apply as necessary.</p>   |  |
| <p>3. DEFINITIONS</p> <p>When performing measurements as described in this Part, the vehicle should be positioned in its normal ride attitude.</p> <p>If the vehicle is fitted with a badge, mascot or other structure, which would bend back or retract under an applied load of maximum 100 N, then this load shall be applied before and/or while these measurements are taken.</p> <p>Any vehicle component which could change shape or position, other than suspension components or active devices to protect pedestrians, shall be set to their stowed position.</p> <p>For the purposes of this regulation:</p> |  |
| <p>3.1. "<u>Adult headform test area</u>" is an area on the outer surfaces of the front structure. The area is bounded, in the front, by a wrap around distance (WAD) of 1,700 mm and, at the rear, by the rear reference line for adult headform and, at each side, by the side reference line.</p>  |  |
| <p>3.2. "<u>A-pillar</u>" means the foremost and outermost roof support extending from</p>  |  |

|   |  |
|---|--|
| the chassis to the roof of the vehicle.   |  |
| 3.3. " <u>Bonnet leading edge</u> " means the edge of the front upper outer structure of the vehicle, including the bonnet and wings, the upper and side members of the headlight surrounds and any other attachments. The reference line identifying the position of the bonnet leading edge is defined by its height above the ground reference plane and by the horizontal distance separating it from the bumper (bumper lead).   |  |
| 3.4. " <u>Bonnet leading edge height</u> " means, at any point on the bonnet leading edge, the vertical distance between the ground reference plane and the bonnet leading edge reference line at that point.   |  |
| 3.5. " <u>Bonnet leading edge reference line</u> " means the geometric trace of the points of contact between a straight edge 1,000 mm long and the front surface of the bonnet, when the straight edge, held parallel to the vertical longitudinal plane of the car and inclined rearwards by 50° from the vertical and with the lower end 600 mm above the ground, is traversed across and in contact with the bonnet leading edge (see Figure 1).<br><br>For vehicles having the bonnet top surface inclined at 50°, so that the straight edge makes a continuous contact or multiple contacts rather than a point contact, determine the reference line with the straight edge inclined rearwards at an angle of 40° from the vertical.<br><br>For vehicles of such shape that the bottom end of the straight edge makes first contact with the vehicle then that contact is taken to be the bonnet leading edge reference line, at that lateral position.<br><br>For vehicles of such shape that the top end of the straight edge makes first contact with the vehicle then the geometric trace of 1,000 mm wrap |  |

|   |  |
|---|--|
| <p>around distance, will be used as bonnet leading edge reference line at that lateral position.</p> <p>The top edge of the bumper shall also be regarded as the bonnet leading edge if it is contacted by the straight edge during this procedure.</p>   |  |
| <p>3.6. "<u>Bonnet rear reference line</u>" means the geometric trace of the most rearward points of contact between a 165 mm diameter sphere and the front structure of the vehicle when the sphere is traversed across the front structure of the vehicle while maintaining contact with the windscreen (see Figure 2). The wiper blades and arms are removed during this process.</p> <p>Where the bonnet rear reference line and the side reference line do not intersect, the bonnet rear reference line should be extended and/or modified using a semi-circular template, of radius 100 mm. The template should be made of a thin flexible sheet material that easily bends to a single curvature in any direction. The template should, preferably, resist double or complex curvature where this could result in wrinkling. The recommended material is a foam backed thin plastic sheet to allow the template to "grip" the surface of the vehicle. The template should be marked up with four points "A" through "D", as shown in Figure 3, while the template is on a flat surface.</p> <p>The template should be placed on the vehicle with Corners "A" and "B" coincident with the side reference line. Ensuring these two corners remain coincident with the side reference line, the template should be slid progressively rearwards until the arc of the template makes first contact with the bonnet rear reference line. Throughout the process, the template should be curved to follow, as closely as possible, the outer contour of the vehicle's bonnet top, without wrinkling or folding of the template. If the contact between the template and bonnet rear reference line is tangential and the point of tangency lies outside the arc scribed by points "C" and</p> |  |

|   |  |
|---|--|
| <p>"D", then the bonnet rear reference line is extended and/or modified to follow the circumferential arc of the template to meet the bonnet side reference line, as shown in Figure 4.</p> <p>If the template cannot make simultaneous contact with the bonnet side reference line at points "A" and "B" and tangentially with the bonnet rear reference line, or the point at which the bonnet rear reference line and template touch lies within the arc scribed by points "C" and "D", then additional templates should be used where the radii are increased progressively in increments of 20 mm, until all the above criteria are met.</p> |  |
| <p>3.7. "<u>Bonnet top</u>" is the area which is bounded by (a), (b) and (c) as follows:<br/>(a) the bonnet leading edge reference line;<br/>(b) the bonnet rear reference line;<br/>(c) the side reference lines.</p>  |  |
| <p>3.8. "<u>Bumper</u>" means the front, lower, outer structure of a vehicle. It includes all structures that are intended to give protection to a vehicle when involved in a low speed frontal collision and also any attachments to this structure. The reference height and lateral limits of the bumper are identified by the corners and the bumper reference lines.</p>   |  |
| <p>3.9. "<u>Bumper lead</u>" means for any longitudinal section of a vehicle, the horizontal distance in the vehicle longitudinal plane between the upper bumper reference line and the bonnet leading edge reference line</p>  |  |
| <p>3.10. "<u>Bumper test area</u>" means the frontal surface of the bumper limited by two longitudinal vertical planes intersecting the corners of the bumper and moved 66 mm parallel and inboard of the corners of the bumpers.</p>   |  |

|   |  |
|---|--|
| 3.11. " <u>Centre of the knee</u> " of the lower legform impactor is defined as the point about which the knee effectively bends.   |  |
| 3.12. " <u>Child headform test area</u> " is an area on the outer surfaces of the front structure. The area is bounded, in the front, by the front reference line for child headform, and, at the rear, by the WAD1700 line, and by the side reference lines.   |  |
| 3.13. " <u>Corner of bumper</u> " means the vehicle's point of contact with a vertical plane which makes an angle of 60° with the vertical longitudinal plane of the car and is tangential to the outer surface of the bumper (see Figure 5).   |  |
| 3.14. " <u>Femur</u> " of the lower legform impactor is defined as all components or parts of components (including flesh, skin covering, damper, instrumentation and brackets, pulleys, etc. attached to the impactor for the purpose of launching it) above the level of the centre of the knee.  |  |
| 3.15. " <u>Front reference line for child headform</u> " means the geometric trace as described on the vehicle front structure using a WAD1000 line. In the case of vehicles where the wrap around distance to the bonnet leading edge reference line, is more than 1,000 mm at any point, then the bonnet leading edge reference line will be used as the front reference line for child headform at that point. |  |
| 3.16. " <u>Front structure</u> " means all outer structures of the vehicle except the windscreen, the windscreen header, the A-pillars and structures rearward of these. It therefore includes, but is not limited to, the bumper, the bonnet, wings, scuttle, wiper spindles and lower windscreen frame.   |  |

|   |  |
|---|--|
| <p>3.17. "<u>Ground reference plane</u>" means a horizontal plane, either real or imaginary, that passes through the lowest points of contact for all tyres of a vehicle while the vehicle is in its normal ride attitude. If the vehicle is resting on the ground, then the ground level and the ground reference plane are one and the same. If the vehicle is raised off the ground such as to allow extra clearance below the bumper, then the ground reference plane is above ground level.</p>  |  |
| <p>3.18. "<u>Head Injury Criterion (HIC)</u>" means the calculated result of accelerometer time histories using the following formula:</p> $\text{HIC} = \left[ \frac{1}{t_2 - t_1} \int_{t_1}^{t_2} a \, dt \right]^{2.5} (t_2 - t_1)$ <p>Where:<br/> a is the resultant acceleration measured in units of gravity "g" (1 g = 9.81 m/s<sup>2</sup>);<br/> t<sub>1</sub> and t<sub>2</sub> are the two time instants (expressed in seconds) during the impact, defining an interval between the beginning and the end of the recording period for which the value of HIC is a maximum (t<sub>2</sub> - t<sub>1</sub> ≤ 15 ms)</p> |  |
| <p>3.19. "<u>Impact point</u>" means the point on the vehicle where initial contact by the test impactor occurs. The proximity of this point to the target point is dependent upon both the angle of travel by the test impactor and the contour of the vehicle surface (see point B in Figure 6).</p>  |  |
| <p>3.20. "<u>Lower bumper height</u>" means the vertical distance between the ground</p>  |  |

|   |   |
|---|---|
| <p>reference plane and the lower bumper reference line, with the vehicle positioned in its normal ride attitude.</p>  |   |
| <p>3.21. "<u>Lower bumper reference line</u>" means the lower limit to significant points of pedestrian contact with the bumper. It is defined as the geometric trace of the lowermost points of contact between a straight edge 700 mm long and the bumper, when the straight edge, held parallel to the vertical longitudinal plane of the car and inclined forwards by 25° from the vertical, is traversed across the front of the car, while maintaining contact with the ground and with the surface of the bumper (see Figure 7).</p>   |   |
| <p>3.22. "<u>Normal ride attitude</u>" means the vehicle positioned on a flat horizontal surface with its mass in running order (as defined in Annex 3, paragraph 3 of Special Resolution No. 1), with the tyres inflated to manufacturer recommended pressures, the front wheels in the straight-ahead position and with a passenger mass (as defined in Annex 3, paragraph 6.2. of Special Resolution No. 1) placed on the front passenger seat. The front seats are placed at the nominal mid-track position. The suspension shall be set in normal running condition as specified by the manufacturer for a speed of 40 km/h.</p> |   |
|   | <p><i>Add new paragraphs:</i><br/>"[3.23 The <b>assessment interval (AI)</b> of the flexible lower legform impactor is defined and limited by the time of first contact of the flexible lower legform impactor with the vehicle and the timing of the last zero crossing of all femur and tibia segments after their first local maximum subsequent to any marginal value of 15 Nm, within their particular common zero crossing phases. The AI is identical for all bone segments and knee ligaments. In case of any</p> |

**Kommentiert [TK1]:** To be decided whether it should say "biodelic assessment interval" or just "assessment interval" as shown.



|  |  |
|--|--|
|  | <p>bone segment not having a zero crossing during the common zero crossing phases, the time history curves for all bone segments are shifted downwards until all bending moments are crossing zero. The downwards shift is to be applied for the determination of the AI only.]</p>  |
|  | <p><b>3.24</b> ‘Primary reference marks‘ means holes, surfaces, marks and identification signs on the vehicle body. The type and the position of reference mark used and the vertical (Z) position of each mark relative to the ground shall be specified by the vehicle manufacturer according to the running conditions specified in paragraph 3.22. These marks shall be selected such as to be able to easily check the vehicle front and rear ride heights and vehicle attitude. The primary reference marks shall be within [<math>\pm 25</math> mm] of the design position in the vertical (Z) axis. All tests are conducted with either the vehicle or all further measurements adjusted to simulate the vehicle being in the design position. This position shall be considered to be the normal ride attitude. "</p> |
| <p>3.23. "<u>Rear reference line for adult headform</u>" means a geometric trace as described on the front structure of the vehicle using a WAD2100 line.</p>  | <p><i>Paragraph 3.23 to 3.31, renumber as paragraphs 3.25 to 3.33</i></p>  |
| <p>3.24. "<u>Side reference line</u>" means the geometric trace of the highest points of contact between a straight edge 700 mm long and the sides of the vehicle, when the straight edge, held parallel to the transverse vertical plane of the vehicle and inclined inwards by 45°, is traversed down, and maintains contact with the sides of the front structure (see Figure 8).</p> |  |

|   |  |
|---|--|
| 3.25. " <u>Target point</u> " means the intersection of the projection of the headform longitudinal axis with the front surface of the vehicle (see point A in Figure 6).   |  |
| 3.26. " <u>Tibia</u> " of the lower legform impactor is defined as all components or parts of components (including flesh, skin covering, instrumentation and brackets, pulleys, etc. attached to the impactor for the purpose of launching it) below the level of the centre of the knee. Note that the tibia as defined includes allowances for the mass, etc., of the foot.  |  |
| 3.27. " <u>Upper bumper reference line</u> " means the upper limit to significant points of pedestrian contact with the bumper. For vehicles with an identifiable bumper structure it is defined as the geometric trace of the uppermost points of contact between a straight edge and the bumper, when the straight edge, held parallel to the vertical longitudinal plane of the car and inclined rearwards by 20° to the vertical, is traversed across the front of the car, while maintaining contact with the surface of the bumper (see Figure 9).<br><br>For vehicles with no identifiable bumper structure it is defined as the geometric trace of the uppermost points of contact between a straight edge 700 mm long and the bumper area, when the straight edge, held parallel to the vertical longitudinal plane of the car and inclined rearwards by 20° from the vertical is traversed across the front of the car, while maintaining contact with the ground and with the surface of the bumper area (see Figure 9). |  |
| 3.28. " <u>Wrap Around Distance (WAD)</u> " means the geometric trace described on the outer surface of the vehicle front structure by one end of a flexible tape, when it is held in a vertical longitudinal plane of the vehicle and traversed across the front structure. The tape is held taut throughout the   |  |

operation with one end held at the same level as the ground reference plane, vertically below the front face of the bumper and the other end held in contact with the front structure (see Figure 10). The vehicle is positioned in the normal ride attitude.

This procedure shall be followed, using alternative tapes of appropriate lengths, to describe wrap around distances of 1,000 mm (WAD1000), of 1,700 mm (WAD1700) and of 2,100 mm (WAD2100).

3.29. "Windscreen" means the frontal glazing of the vehicle situated between the A-pillars.

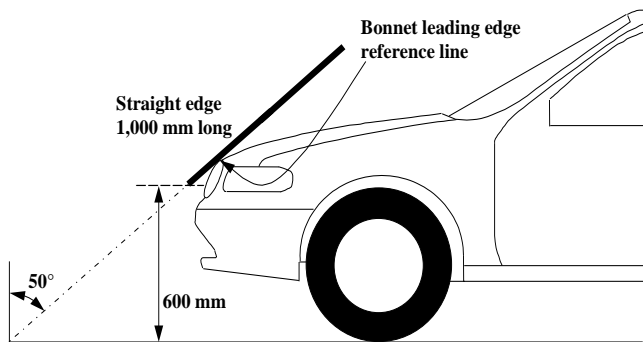


Figure 1: Bonnet leading edge reference line (see paragraph 3.5.)

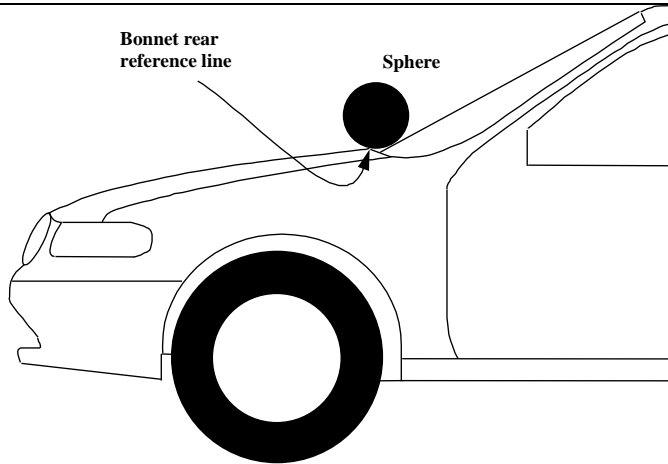


Figure 2: Bonnet rear reference line. (see paragraph 3.6.)

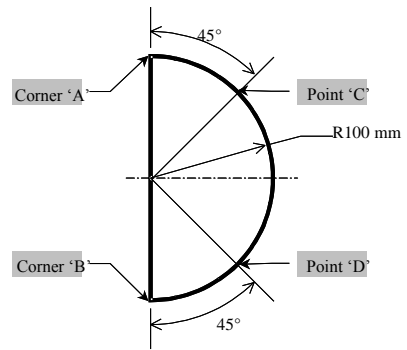


Figure 3: Template (see paragraph 3.6.)

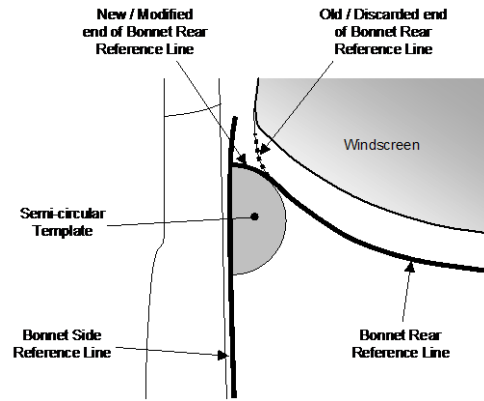


Figure 4: Marking of intersection between bonnet rear and side reference lines (see paragraph 3.6.)

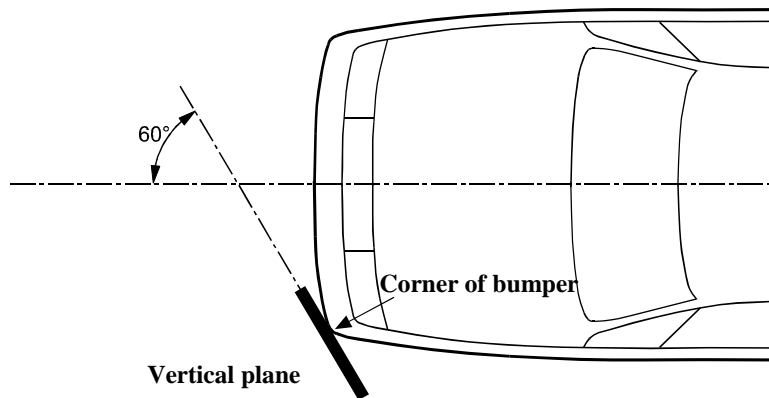
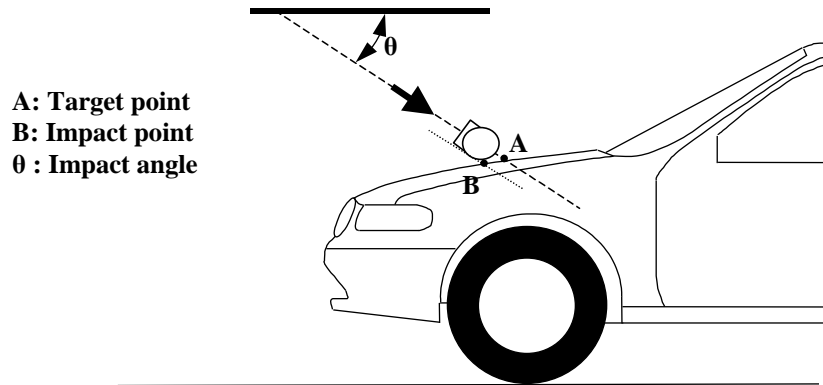
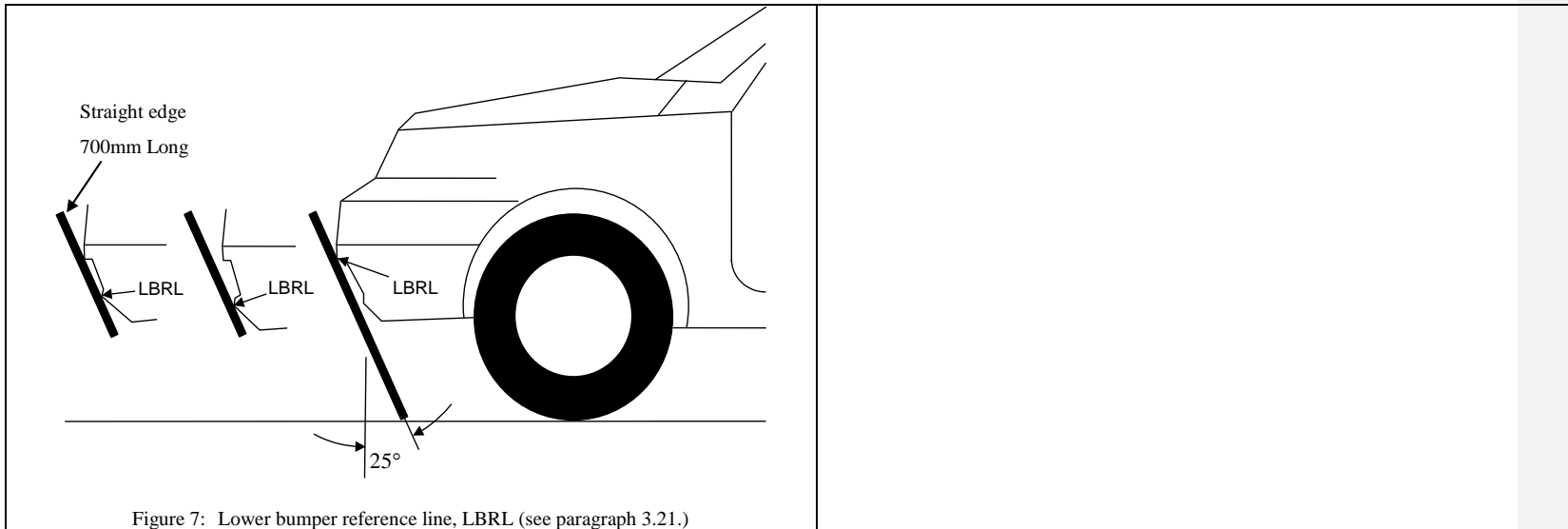


Figure 5: Corner of bumper (see paragraph 3.13.)

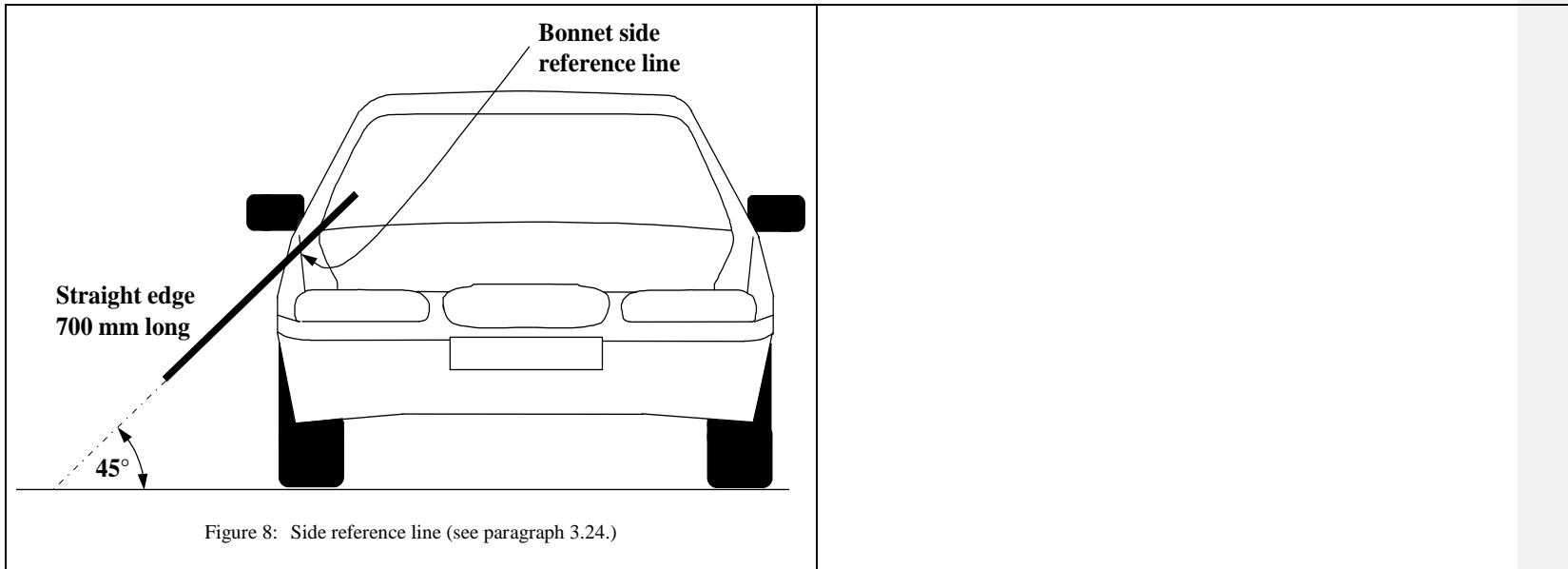


**A: Target point**  
**B: Impact point**  
 **$\theta$  : Impact angle**

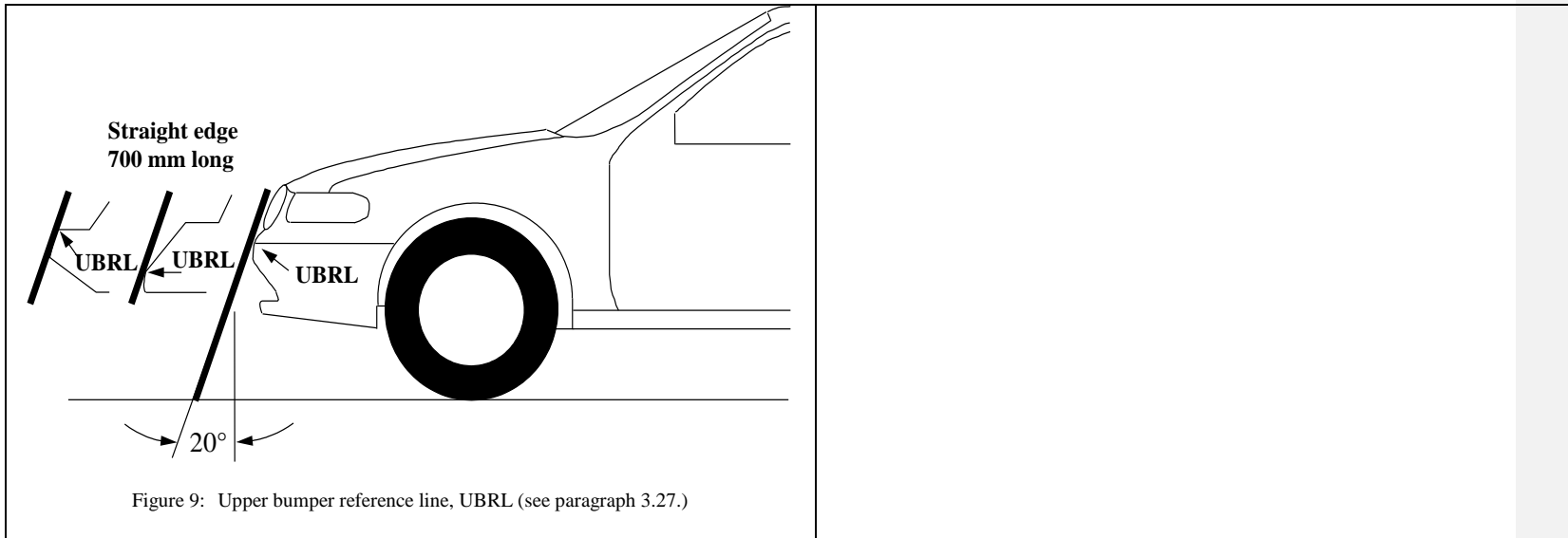
Figure 6: Impact and target point (see paragraphs 3.19. and 3.25.)



...







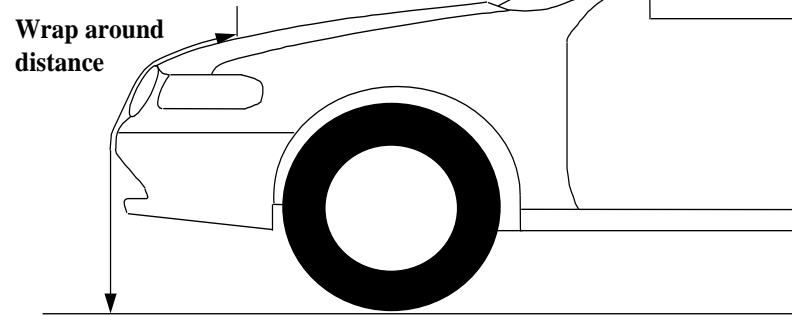


Figure 10: Wrap around distance measurement (see paragraph 3.28.)

4. GENERAL REQUIREMENTS

This global technical regulation specifies the following tests to verify compliance of vehicles.

4.1. Legform test to bumper:

For vehicles with a lower bumper height of less than 425 mm the requirements of paragraph 4.1.1. shall be applied.

For vehicles with a lower bumper height which is greater than, or equal to 425 mm and less than 500 mm the requirements of either paragraph 4.1.1. or 4.1.2., at the choice of the manufacturer, shall be applied.

|   |  |
|---|--|
| <p>For vehicles with a lower bumper height of greater than, or equal to, 500 mm the requirements of paragraph 4.1.2. shall be applied.</p>  |  |
| <p>4.1.1. Lower legform to bumper:</p> <p>To verify compliance with the performance requirements as specified in paragraph 5.1.1., both the test impactor specified in paragraph 6.3.1.1. and the test procedures specified in paragraph 7.1.1. shall be used.</p>            |  |
| <p>4.1.2. Upper legform to bumper:</p> <p>To verify compliance with the performance requirements as specified in paragraph 5.1.2., both the test impactor specified in paragraph 6.3.1.2. and the test procedures specified in paragraph 7.1.2. shall be used.</p>            |  |
| <p>4.2. <u>Child headform impact:</u></p> <p>To verify compliance with the performance requirements as specified in paragraph 5.2.1., both the test impactor specified in paragraph 6.3.2.1. and the test procedures specified in paragraphs 7.2. and 7.3. shall be used.</p> |  |
| <p>4.3. <u>Adult headform impact:</u></p> <p>To verify compliance with the performance requirements as specified in paragraph 5.2.2., both the test impactor specified in paragraph 6.3.2.2. and the test procedures specified in paragraphs 7.2. and 7.4. shall be used.</p> |  |

|   |  |
|---|--|
| 5. PERFORMANCE REQUIREMENTS   |  |
| 5.1. <u>Legform to bumper:</u>  |  |
| 5.1.1. When tested in accordance with paragraph 7.1.1. (lower legform to bumper), the maximum dynamic knee bending angle shall not exceed 19°, the maximum dynamic knee shearing displacement shall not exceed 6.0 mm, and the acceleration measured at the upper end of the tibia shall not exceed 170g. In addition, the manufacturer may nominate bumper test widths up to a maximum of 264 mm in total where the acceleration measured at the upper end of the tibia shall not exceed 250g. | <p><b>"5.1.1. When tested in accordance with paragraph 7.1.1. (lower legform to bumper), the absolute value of the maximum dynamic medial collateral ligament elongation at the knee shall not exceed [22 mm], and the maximum dynamic anterior cruciate ligament and posterior cruciate ligament elongation shall not exceed [13 mm]. The absolute value of dynamic bending moments at the tibia shall not exceed [340 Nm]. [In addition, the manufacturer may nominate bumper test widths up to a maximum of 264 mm in total where the absolute value of the tibia bending moment shall not exceed [380 Nm]. A Contracting Party may restrict application of the relaxation zone requirement in its domestic legislation if it decides that such restriction is appropriate.]"</b></p> <p><del>When tested in accordance with paragraph 7.1.1. (lower legform to bumper), the maximum dynamic knee bending angle shall not exceed 19°, the maximum dynamic knee shearing displacement shall not exceed 6.0 mm, and the acceleration measured at the upper end of the tibia shall not exceed 170g. In addition, the manufacturer may nominate bumper test widths up to a maximum of 264 mm in total where the acceleration measured at the upper end of the tibia shall not exceed 250g."</del></p> |

**Kommentiert [TK2]:** OICA requests to extend the relaxation zone also to the knee section with maximum MCL elongation of [24 mm] and maximum ACL/PCL elongation of [14.5 mm]. BAST and the EC wonder whether a relaxation zone is needed at all.

|          |  |
|----------|--|
|          |  |
| 5.1.2.   | When tested in accordance with paragraph 7.1.2. (upper legform to bumper), the instantaneous sum of the impact forces with respect to time shall not exceed 7.5 kN and the bending moment on the test impactor shall not exceed 510 Nm.  |
| 5.2.     | <u>Headform tests</u>  |
| 5.2.1.   | Child headform to the front structure:<br><br>When tested in accordance with paragraphs 7.2. and 7.3. the HIC shall comply with paragraph 5.2.3.   |
| 5.2.2.   | Adult headform to the front structure:<br><br>When tested in accordance with paragraph 7.2. and 7.4. the HIC shall comply with paragraph 5.2.3.  |
| 5.2.3.   | The HIC recorded shall not exceed 1,000 over a minimum of one half of the child headform test area and 1,000 over two thirds of the combined child and adult headform test areas. The HIC for the remaining areas shall not exceed 1,700 for both headforms.<br><br>In case there is only a child headform test area, the HIC recorded shall not exceed 1,000 over two thirds of the test area. For the remaining area the HIC shall not exceed 1,700. |
| 5.2.4.   | Splitting of headform test zone  |
| 5.2.4.1. | The manufacturer shall identify the zones of the bonnet top where the HIC must not exceed 1,000 (HIC1000 Zone) or 1,700 (HIC1700 Zone) (see Figure 11).  |

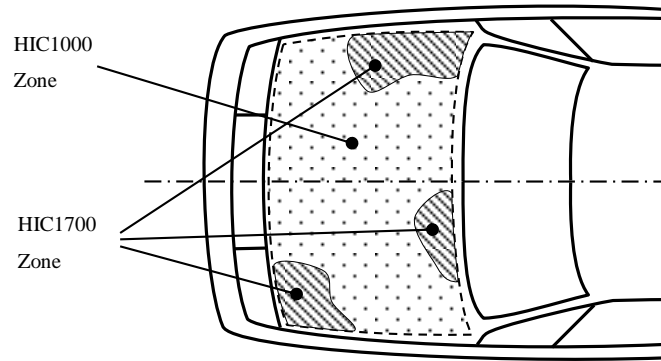


Figure 11: Example of marking of HIC1000 zone and HIC1700 zone

5.2.4.2. Marking of the "bonnet top" impact area as well as "HIC1000 Zone" and "HIC1700 Zone" will be based on a drawing supplied by the manufacturer, when viewed from a horizontal plane above the vehicle that is parallel to the vehicle horizontal zero plane. A sufficient number of x and y co-ordinates shall be supplied by the manufacturer to mark up the areas on the actual vehicle while considering the vehicle outer contour in the z direction.

5.2.4.3. The areas of "HIC1000 Zone" and "HIC1700 Zone" may consist of several parts, with the number of these parts not being limited. The determination of the impacted zone is done by the first contact point of the headform with the "bonnet top."

5.2.4.4. The calculation of the surface of the impact area as well as the surface areas of "HIC1000 Zone" and "HIC1700 Zone" shall be done

|          |   |  |
|----------|---|--|
|          | on the basis of a projected bonnet when viewed from a horizontal plane parallel to the horizontal zero plane above the vehicle, on the basis of the drawing data supplied by the manufacturer.  |  |
| 6.       | <b>TEST SPECIFICATIONS</b>  |  |
| 6.1.     | <u>General test conditions</u>  |  |
| 6.1.1.   | Temperature and humidity<br><br>At the time of testing, the test facility and the vehicle or sub-system shall have a relative humidity of 40 percent $\pm$ 30 percent and stabilized temperature of 20 $\pm$ 4 °C.  |  |
| 6.1.2.   | Impact test site<br><br>The test site shall consist of a flat, smooth and hard surface with a slope not exceeding 1 percent.  |  |
| 6.2.     | <u>Preparation of the vehicle</u>   |  |
| 6.2.1.   | Either a complete vehicle, or a cut-body, adjusted to the following conditions shall be used for the test.  |  |
| 6.2.1.1. | The vehicle shall be in its normal ride attitude, and shall be either securely mounted on raised supports or at rest on a flat horizontal surface with the parking brake applied.   |  |
| 6.2.1.2. | The cut-body shall include, in the test, all parts of the vehicle front structure, all under-bonnet components and all components behind the windscreen that may be involved in a frontal impact with a vulnerable road user, to demonstrate the performance and interactions |  |

|   |   |
|---|---|
| <p>of all the contributory vehicle components. The cut-body shall be securely mounted in the normal vehicle ride attitude.</p>  |   |
| <p>6.2.2. All devices designed to protect vulnerable road users when impacted by the vehicle shall be correctly activated before and/or be active during the relevant test. It shall be the responsibility of the manufacturer to show that any devices will act as intended in a pedestrian impact.</p>  |   |
| <p>6.2.3. For vehicle components which could change shape or position, other than active devices to protect pedestrians, and which have more than one fixed shape or position shall require the vehicle to comply with the components in each fixed shape or position.</p>  |   |
| <p>6.3. <u>Test impactor specifications</u></p> <p>6.3.1. Legform impactors:</p>  |   |
| <p>6.3.1.1. Lower legform impactor:</p> <p>The lower legform impactor shall consist of two foam covered rigid segments, representing femur (upper leg) and tibia (lower leg), joined by a deformable, simulated knee joint. The overall length of the impactor shall be <math>926 \pm 5</math> mm, having a required test mass of <math>13.4 \pm 0.2</math> kg (see Figure 12). Dimensions of the various parts are detailed in Figure 12.</p> <p>Brackets, pulleys, etc. attached to the impactor for the purpose of launching it, may extend the dimensions shown in Figure 12.</p> | <p>"6.3.1.1. <b>Flexible lower</b> <del>Lower</del> legform impactor:</p> <p><b>The flexible lower legform impactor shall consist of the flesh and skin, the flexible long bone segments (representing the femur and the tibia), and the knee joint as shown in Figure 12.</b></p> <p><b>The assembled length of the impactor shall be <math>928 [\pm 3]</math> mm, having a total mass of <math>13.2 \pm [0.7]</math> kg]. When fully assembled in the impactor, the measurable lengths of the femur shall be <math>339 [\pm 2]</math> mm, of the knee joint shall be <math>185 [\pm 1]</math> mm and of the tibia shall be <math>404 [\pm 2]</math> mm. The knee joint centre position shall be <math>94 [\pm 1]</math> mm from the top of the knee joint at the vertical centre line</b></p> |

**Kommentiert [TK3]:** OICA proposes that all tolerances for the length should be covered by figure 12 and taken off this paragraph to improve readability.

**Kommentiert [TK4]:** OICA requests to lower the weight tolerance to  $13.2 \pm 0.07$  kg; Humanetics will check whether the same level as currently with the EEVC LFI can be achieved ( $\pm 1.5$  %).



|   |  |
|---|--|
|   | <p><b>of the knee.</b></p> <p><b>Brackets, pulleys, protectors, connection parts, etc. attached to the impactor for the purposes of launching and/or protection may extend beyond the dimensions and tolerances shown in Figure 12 and Figure 13.</b></p> <p><del>The lower legform impactor shall consist of two foam covered rigid segments, representing femur (upper leg) and tibia (lower leg), joined by a deformable, simulated knee joint. The overall length of the impactor shall be <math>926 \pm 5</math> mm, having a required test mass of <math>13.4 \pm 0.2</math> kg (see Figure 12).</del></p> <p><del>—Brackets, pulleys, etc. attached to the impactor for the purpose of launching it, may extend the dimensions shown in Figure 12. “</del></p>              |
| <p>6.3.1.1.1. The diameter of the femur and tibia shall be <math>70 \pm 1</math> mm and both shall be covered by foam flesh and skin. The foam flesh shall be 25 mm thick foam type CF-45 or equivalent. The skin shall be made of neoprene foam, faced with 0.5 mm thick nylon cloth on both sides, with an overall thickness of 6 mm.</p> | <p>6.3.1.1.1. <b>The cross-sectional shape perpendicular to the Z-axis of the femur and the tibia main body segments shall be <math>90 [\pm 2]</math> mm in width along the Y-axis, and <math>84 [\pm 1]</math> mm in width along the X-axis as shown in Figure 13 (a). The impact face shall be <math>30 [\pm 1]</math> mm in radius, <math>30 [\pm 1]</math> mm in width along the Y-axis, and <math>48 [\pm 1]</math> mm in width along the X-axis as shown in Figure 13 (a).</b></p> <p><del>The diameter of the femur and tibia shall be <math>70 \pm 1</math> mm and both shall be covered by foam flesh and skin. The foam flesh shall be 25 mm thick foam type CF 45 or equivalent. The skin shall be made of neoprene foam, faced with 0.5 mm thick nylon cloth</del></p> |

**Kommentiert [TK5]:** Proposal of OICA to add tolerances to figure 13 (a), delete the whole paragraph and say “The cross sectional shape of the femur and the tibia main body segments shall be as defined in figure 13 (a).”

|  |  |
|--|--|
|  | <p>on both sides, with an overall thickness of 6 mm.</p>   |
| <p>6.3.1.1.2. The knee joint shall be fitted with deformable knee elements from the same batch as those used in the certification tests.</p>   | <p>6.3.1.1.2. <b>The cross-sectional shape perpendicular to the Z-axis of the knee joint shall be 108 [± 2] mm in width along the Y-axis, and 118 [± 1] mm in width along the X-axis as shown in Figure 13 (b). The impact face shall be 103 [± 1] mm in radius, 12 [± 1] mm in width along the Y-axis, and 86 [± 1] mm in width along the X-axis as shown in Figure 13 (b).</b></p> <p>The knee joint shall be fitted with deformable knee elements from the same batch as those used in the certification tests.</p>   |
| <p>6.3.1.1.3. The total masses of the femur and tibia shall be <math>8.6 \pm 0.1</math> kg and <math>4.8 \pm 0.1</math> kg respectively, and the total mass of the impactor shall be <math>13.4 \pm 0.2</math> kg. The centre of gravity of the femur and tibia shall be <math>217 \pm 10</math> mm and <math>233 \pm 10</math> mm from the centre of the knee respectively. The moment of inertia of the femur and tibia, about a horizontal axis through the respective centre of gravity and perpendicular to the direction of impact, shall be <math>0.127 \pm 0.010</math> kgm<sup>2</sup> and <math>0.120 \pm 0.010</math> kgm<sup>2</sup> respectively.</p> | <p>6.3.1.1.3. <b>The masses of the femur and the tibia without the flesh and skin, including the connection parts to the knee joint, shall be 2.46 [± 0.12] kg and 2.64 [± 0.13] kg respectively. The mass of the knee joint without the flesh and skin shall be 4.28 [± 0.21] kg. The assembled mass of the femur, the knee joint and the tibia without the flesh and skin shall be <math>9.38 \pm 0.46</math> kg.</b></p> <p>The centres of gravity of the femur and tibia without the flesh and skin, including the connection parts to the knee joint, shall be <math>159 \pm 8</math> mm and <math>202 \pm 10</math> mm respectively from the top, but not including the connection part to the knee joint, of each part as shown in Figure 12. The centre of gravity of the knee shall be <math>92 \pm 5</math> mm from the top of the knee joint as shown</p> |

**Kommentiert [TK6]:** Proposal of OICA to add tolerances to figure 13 (b), delete the whole paragraph and say "The cross sectional shape of the knee joint shall be as defined in figure 13 (b)."

**Kommentiert [TK7]:** OICA proposes the mass tolerances to be reduced. In addition, this whole section is sufficiently described in figures 12 and 13 if the tolerances were added there. Humanetics will double-check the possibility to reduce the tolerances.

**Kommentiert [TK8]:** OICA believes that the tolerance needs to refer to a point that can be measured directly, e.g. 202 mm from the bottom of the tibia. Then, this section of the paragraph can be deleted.

...

|   |  |
|---|--|
|   | <p><b>in Figure 12.</b></p> <p><b>The moment of inertia of the femur and the tibia without the flesh and skin, including the connection parts inserted to the knee joint, about the X-axis through the respective centre of gravity shall be <math>0.0325 \pm 0.0016 \text{ kgm}^2</math> and <math>0.0467 \pm 0.0023 \text{ kgm}^2</math> respectively. The moment of inertia of the knee joint about the X-axis through the respective centre of gravity shall be <math>0.0180 \pm 0.0009 \text{ kgm}^2</math>.</b></p> <p><del>The total masses of the femur and tibia shall be <math>8.6 \pm 0.1 \text{ kg}</math> and <math>4.8 \pm 0.1 \text{ kg}</math> respectively, and the total mass of the impactor shall be <math>13.4 \pm 0.2 \text{ kg}</math>. The centre of gravity of the femur and tibia shall be <math>217 \pm 10 \text{ mm}</math> and <math>233 \pm 10 \text{ mm}</math> from the centre of the knee respectively. The moment of inertia of the femur and tibia, about a horizontal axis through the respective centre of gravity and perpendicular to the direction of impact, shall be <math>0.127 \pm 0.010 \text{ kgm}^2</math> and <math>0.120 \pm 0.010 \text{ kgm}^2</math> respectively.</del></p> |
| <p>6.3.1.1.4. For each test the impactor shall be fitted with new foam flesh cut from one of up to four consecutive sheets of foam type CF-45 flesh material or equivalent, produced from the same batch of manufacture (cut from one block or 'bun' of foam), provided that foam from one of these sheets was used in the dynamic certification test and the individual weights of these sheets are within <math>\pm 2</math> percent of the weight of the sheet used in the certification test.</p> | <p><b>6.3.1.1.4. For each test, the impactor (femur, knee joint and tibia) shall be covered by the flesh and skin composed of synthetic rubber sheets (R1, R2) and neoprene sheets (N1F, N2F, N1T, N2T, N3) as shown in Figure 14. The size of the sheets shall be within the requirements described in Figure 15. The sheets are required to have compression characteristics as shown in Figure 15. The compression characteristics shall be checked using material from the same batch as the sheets</b></p>  |

|  |  |
|--|--|
|  | <p><b>used for the impactor flesh and skin.</b></p> <p><del>For each test the impactor shall be fitted with new foam flesh cut from one of up to four consecutive sheets of foam type CF 45 flesh material or equivalent, produced from the same batch of manufacture (cut from one block or 'bun' of foam), provided that foam from one of these sheets was used in the dynamic certification test and the individual weights of these sheets are within <math>\pm 2</math> percent of the weight of the sheet used in the certification test.</del></p>  |
| <p>6.3.1.1.5. The test impactor or at least the foam flesh shall be stored during a period of at least four hours in a controlled storage area with a stabilized humidity of 35 percent <math>\pm</math> 15 percent and a stabilized temperature of <math>20 \pm 4^\circ\text{C}</math> prior to impactor removal for test. After removal from the storage the impactor shall not be subjected to conditions other than those pertaining in the test area.</p> | <p><b>6.3.1.1.5. All impactor components shall be stored for a sufficient period of time in a controlled storage area with a stabilized temperature of <math>20 \pm 4^\circ\text{C}</math> prior to the impactor removal for testing. After removal from the storage, the impactor shall not be subjected to conditions other than those in the test area as defined in section 6.1.1.</b></p> <p><del>The test impactor or at least the foam flesh shall be stored during a period of at least four hours in a controlled storage area with a stabilized humidity of 35 percent <math>\pm</math> 15 percent and a stabilized temperature of <math>20 \pm 4^\circ\text{C}</math> prior to impactor removal for calibration. After removal from the storage the impactor shall not be subjected to conditions other than those pertaining in the test area.</del></p> |
| <p>6.3.1.1.6. Lower legform instrumentation</p>  | <p>6.3.1.1.6. Lower legform instrumentation</p>  |

|   |  |
|---|--|
| <p>6.3.1.1.6.1. A uniaxial accelerometer shall be mounted on the non-impacted side of the tibia, <math>66 \pm 5</math> mm below the knee joint centre, with its sensitive axis in the direction of impact.</p>  | <p><b>6.3.1.1.6.1. Four transducers shall be installed in the tibia to measure bending moments applied to the tibia. The sensing locations of each of the transducers are as follows: tibia-1: <math>134 \pm 1</math> mm, tibia-2: <math>214 \pm 1</math> mm, tibia-3: <math>294 \pm 1</math> mm and tibia-4: <math>374 \pm 1</math> mm below the knee joint centre respectively as shown in Figure 16. The measurement axis of each transducer shall be the X-axis of the impactor.</b></p> <p><del>A uniaxial accelerometer shall be mounted on the non-impacted side of the tibia, <math>66 \pm 5</math> mm below the knee joint centre, with its sensitive axis in the direction of impact.</del></p>  |
| <p>6.3.1.1.6.2. A damper shall be fitted to the shear displacement system and may be mounted at any point on the rear face of the impactor or internally. The damper properties shall be such that the impactor meets both the static and dynamic shear displacement requirements and prevents excessive vibrations of the shear displacement system.</p> | <p><b>6.3.1.1.6.2. Three transducers shall be installed in the knee joint to measure elongations of the medial collateral ligament (MCL), anterior cruciate ligament (ACL), and posterior cruciate ligament (PCL). The measurement locations of each transducer are shown in Figure 16. The measurement locations shall be within <math>\pm 4</math> mm along the X-axis from the knee joint centre.</b></p> <p><del>A damper shall be fitted to the shear displacement system and may be mounted at any point on the rear face of the impactor or internally. The damper properties shall be such that the impactor meets both the static and dynamic shear displacement requirements and prevents excessive vibrations of the shear displacement system.</del></p> |

|   |   |
|---|---|
| <p>6.3.1.1.6.3. Transducers shall be fitted to measure knee bending angle and knee shearing displacement.</p>   | <p><b>6.3.1.1.6.3. The instrumentation response value channel frequency class (CFC), as defined in ISO 6487:2002, shall be 180 for all transducers. The CAC response values, as defined in ISO 6487:2002, shall be 30 mm for the knee ligament elongations and 400 Nm for the tibia bending moments.</b></p> <p><del>Transducers shall be fitted to measure knee bending angle and knee shearing displacement.</del></p>  |
| <p>6.3.1.1.6.4. The instrumentation response value channel frequency class (CFC), as defined in ISO 6487:2002, shall be 180 for all transducers. The CAC response values, as defined in ISO 6487:2002, shall be 50° for the knee bending angle, 10 mm for the shearing displacement and 500g for the acceleration. This does not require that the impactor itself be able to physically bend and shear to these angles and displacements.</p> | <p><b>6.3.1.1.6.4. The determination of all flexible lower legform impactor peak tibia bending moments and ligament elongations shall be limited to the assessment interval (AI) as defined in paragraph 3.23.</b></p> <p><b><del>The measurements for the flexible lower legform impactor shall be taken only for the major impact with the vehicle prior to the rebound phase. All maxima occurring during or after the rebound phase shall be ignored. For example, the zero crossing after the maximum of the MCL elongation or of the tibia bending moments shall be considered as the end of the major impact with the vehicle.</del></b></p> <p><del>The instrumentation response value channel frequency class (CFC), as defined in ISO 6487:2002, shall be 180 for all transducers. The CAC response values, as defined in ISO 6487:2002, shall be 50° for the knee bending angle, 10 mm for</del></p> |

|   |   |
|---|---|
|   | <p><del>the shearing displacement and 500g for the acceleration. This does not require that the impactor itself be able to physically bend and shear to these angles and displacements.</del></p>   |
| <p>6.3.1.1.7. Lower legform certification</p>   | <p>6.3.1.1.7. <b>Flexible lower legform impactor</b> <del>Lower legform certification</del></p>   |
| <p>6.3.1.1.7.1. The lower legform impactor shall meet the performance requirements specified in paragraph 8.</p>  | <p>6.3.1.1.7.1. The <b>flexible lower legform impactor</b> <del>lower legform</del> shall meet the performance requirements specified in paragraph 8.</p>   |
| <p>6.3.1.1.7.2. The certified impactor may be used for a maximum of 20 impacts before re-certification. With each test new plastically deformable knee elements should be used. The impactor shall also be re-certified if more than one year has elapsed since the previous certification, if any impactor transducer output, in any impact, has exceeded the specified CAC or has reached the mechanical limits of the leg impactor deformation capability.</p> | <p><b>6.3.1.1.7.2. The impactor shall be certified using two certification tests as follows: First, the certification shall be conducted according to the inverse certification (IC) test procedure prescribed in paragraph 8.1.3 before starting a vehicle test series. Second, after a maximum of 10 vehicle tests, certification should be conducted according to the pendulum certification (PC) test procedure prescribed in paragraph 8.1.2. Certification testing then shall follow the sequence IC – PC – PC – IC – PC – PC – etc. with a maximum of 10 tests between each certification.</b></p> <p><b>In addition, the impactor shall be certified according to the procedures prescribed in paragraph 8.1 at least once a year.</b></p> <p><del>The certified impactor may be used for a maximum</del></p> |

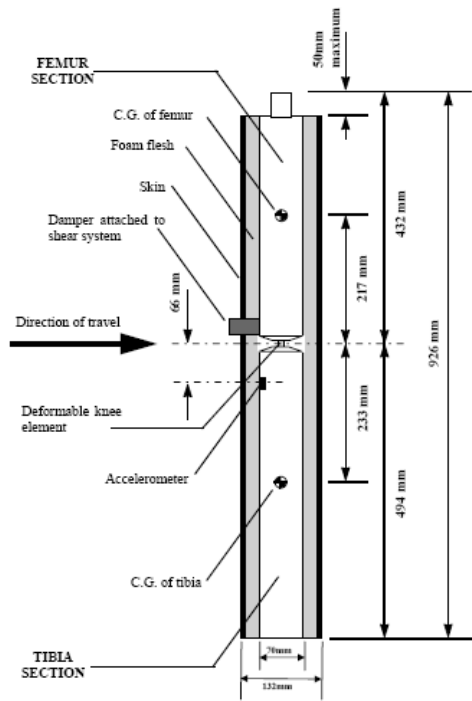
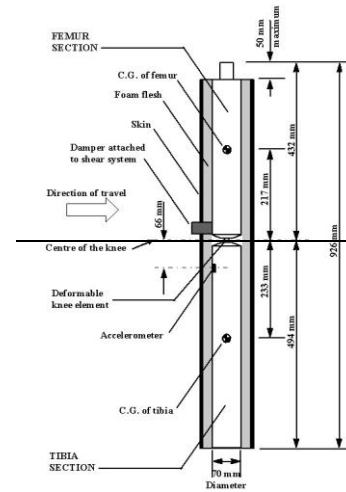


Figure 12: Lower legform impactor (see paragraph 6.3.1.1.)

of 10 impacts before re certification. With each test new plastically deformable knee elements should be used. The impactor shall also be re certified if more than one year has elapsed since the previous certification, if any impactor transducer output, in any impact, has exceeded the specified CAC or has reached the mechanical limits of the leg impactor deformation capability."

Delete Figures 12, to read:

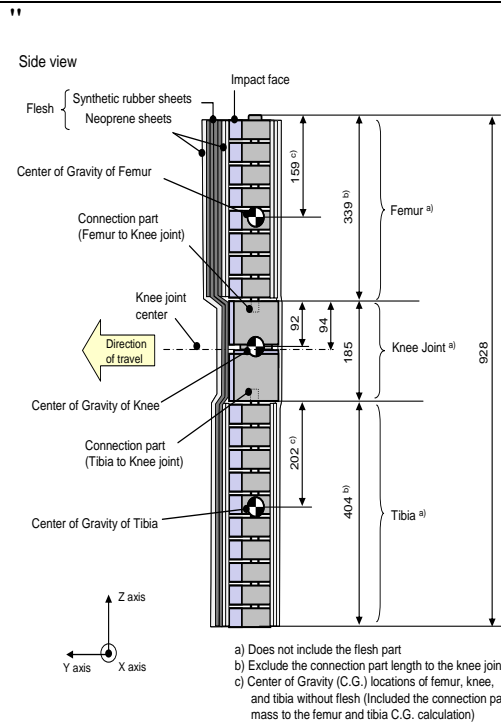


**Figure 12: Lower legform impactor (see paragraph 6.3.1.1.)**

Insert new Figures 12 to 16, to read:

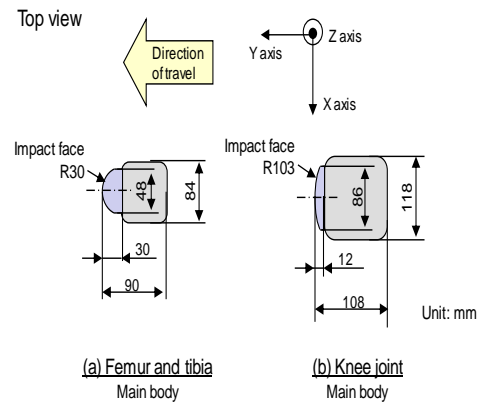
...





**Figure 12: Flexible lower legform impactor: Dimensions and center of gravity locations of femur, knee joint and tibia (side view)**

**Kommentiert [TK9]:** See above: Figure should contain the respective tolerances.



**Figure 13: Flexible lower legform impactor: schematic plan views of femur, tibia, and knee dimensions (top view)**

**Kommentiert [TK10]:** See above: Figure should contain the respective tolerances.

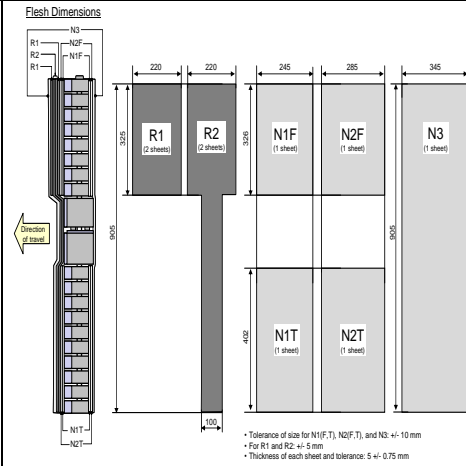
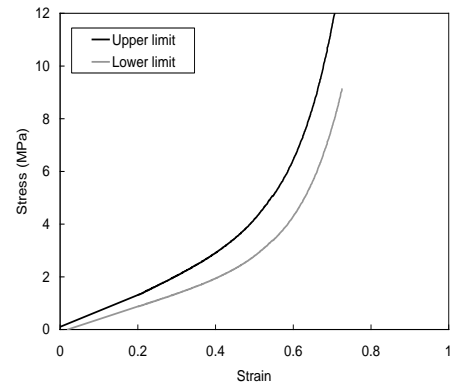


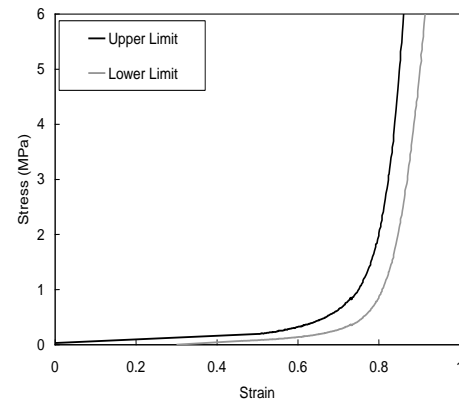
Figure 14: Flexible lower legform impactor: flesh and skin dimensions

Kommentiert [TK11]: Humanetics noted that the skin tolerance changes from 5 to 5.6 mm; this needs to be reflected in this figure.



...

**(a) Synthetic rubber sheets**

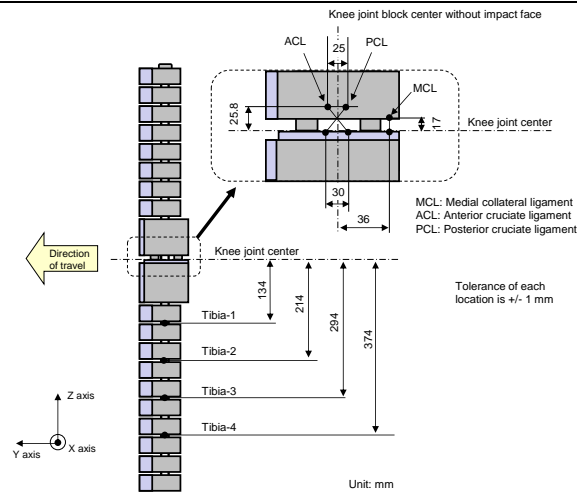


**(b) Neoprene sheets**

**Figure 15: Flexible lower legform impactor: flesh and skin compression characteristics**

**Kommentiert [TK12]:** Humanetics will change this diagram to address the changes to the neoprene skin.

...



**Figure 16: Flexible lower legform impactor; instrument locations"**

|   |   |
|---|---|
| <p>6.3.1.2. Upper legform impactor:</p> <p>The upper legform impactor shall be rigid, foam covered at the impact side, and <math>350 \pm 5</math> mm long (see Figure 13).</p>  | <p><i>Paragraph 6.3.1.2., amend to read:</i><br/>                 "..., foam covered at the impact side, and <math>350 \pm 5</math> mm long (see Figure 1317)."</p> |
| <p>6.3.1.2.1. The total mass of the upper legform impactor including those propulsion and guidance components which are effectively part of the impactor during the impact shall be <math>9.5 \text{ kg} \pm 0.1 \text{ kg}</math>.</p> |   |
| <p>6.3.1.2.2. The total mass of the front member and other components in front of the load transducer assemblies, together with those parts of the load transducer assemblies in front of the active elements, but ex-</p>              |   |

|  |  |
|--|--|
| cluding the foam and skin, shall be $1.95 \pm 0.05$ kg.  |  |
| 6.3.1.2.3. The upper legform impactor for the bumper test shall be mounted to the propulsion system by a torque limiting joint and be insensitive to off-axis loading. The impactor shall move only in the specified direction of impact when in contact with the vehicle and shall be prevented from motion in other directions including rotation about any axis.  |  |
| 6.3.1.2.4. The torque limiting joint shall be set so that the longitudinal axis of the front member is vertical at the time of impact with a tolerance of $\pm 2^\circ$ , with the joint friction torque set to $675 \text{ Nm} \pm 25 \text{ Nm}$ .   |  |
| 6.3.1.2.5. The centre of gravity of those parts of the impactor which are effectively forward of the torque limiting joint, including any weights fitted, shall lie on the longitudinal centre line of the impactor, with a tolerance of $\pm 10$ mm.  |  |
| 6.3.1.2.6. The length between the load transducer centre lines shall be $310 \pm 1$ mm and the front member diameter shall be $50 \pm 1$ mm.   |  |
| 6.3.1.2.7. For each test the foam flesh shall be two new sheets of 25 mm thick foam type CF-45 or equivalent, which shall be cut from the sheet of material used for the dynamic certification test. The skin shall be a 1.5 mm thick fibre reinforced rubber sheet. The mass of the foam and the rubber skin together shall be $0.6 \pm 0.1$ kg (this excludes any reinforcement, mountings, etc. which are used to attach the rear edges of the rubber skin to the rear member). The foam and rubber skin shall be folded back towards the rear, with the rubber skin attached via spacers to the rear member so that the sides of the rubber skin are held parallel. The foam shall be of such a size and shape that an adequate gap is maintained between the foam and components behind the front member, to avoid significant load paths be- |  |

|   |   |
|---|---|
| <p>tween the foam and these components.</p>   |   |
| <p>6.3.1.2.8. The test impactor or at least the foam flesh shall be stored during a period of at least four hours in a controlled storage area with a stabilized humidity of 35 percent <math>\pm</math> 15 percent and a stabilized temperature of 20 <math>\pm</math> 4 °C prior to impactor removal for test. After removal from the storage the impactor shall not be subjected to conditions other than those pertaining in the test area.</p>       |   |
| <p>6.3.1.2.9. Upper legform instrumentation</p>   |   |
| <p>6.3.1.2.9.1. The front member shall be strain gauged to measure bending moments in three positions, as shown in Figure 13, each using a separate channel. The strain gauges are located on the impactor on the back of the front member. The two outer strain gauges are located 50 <math>\pm</math> 1 mm from the impactor's symmetrical axis. The middle strain gauge is located on the symmetrical axis with a <math>\pm</math> 1 mm tolerance.</p> | <p><i>Paragraph 6.3.1.2.9.1., amend to read:</i><br/>                 "...in three positions, as shown in Figure <del>13</del>17, each using a separate channel. ...."</p>  |
| <p>6.3.1.2.9.2. Two load transducers shall be fitted to measure individually the forces applied at either end of the upper legform impactor, plus strain gauges measuring bending moments at the centre of the upper legform impactor and at positions 50 mm either side of the centre line (see Figure 13).</p>  | <p><i>Paragraph 6.3.1.2.9.2., amend to read:</i><br/>                 "...at positions 50 mm either side of the centre line (see Figure <del>13</del>17)."<br/> <i>Title of Figure 13(former), renumber as Figure 17.</i></p> |
| <p>6.3.1.2.9.3. The instrumentation response value CFC, as defined in ISO 6487:2002, shall be 180 for all transducers. The CAC response values, as defined in ISO 6487:2002, shall be 10 kN for the force transducers and 1,000 Nm for the bending moment measurements.</p>   |   |
| <p>6.3.1.2.10. Upper legform certification</p>  |   |
| <p>6.3.1.2.10.1. The upper legform impactor shall meet the performance require-</p>   |   |

ments specified in paragraph 8.

6.3.1.2.10.2. The certified impactor may be used for a maximum of 20 impacts before re-certification (this limit does not apply to propulsion or guidance components). The impactor shall also be re-certified if more than one year has elapsed since the previous certification or if any impactor transducer output, in any impact, has exceeded the specified CAC.

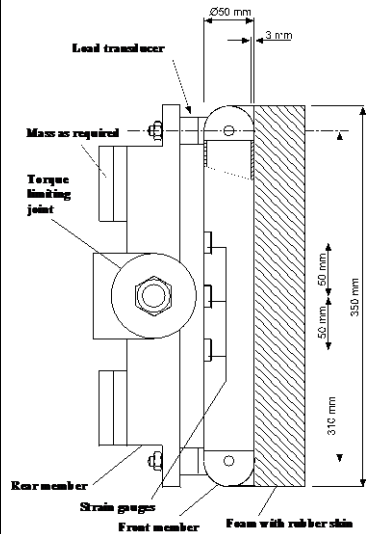


Figure 13: Upper legform impactor (see paragraph 6.3.1.2.)

6.3.2. Child and adult headform impactors

6.3.2.1. Child headform impactor (see Figure 14)

Paragraph 6.3.2.1., amend to read:

...



|  |   |
|--|---|
| <p>The child headform impactor shall be made of aluminium, be of homogenous construction and be of spherical shape. The overall diameter shall be <math>165 \pm 1</math> mm. The mass shall be <math>3.5 \pm 0.07</math> kg. The moment of inertia about an axis through the centre of gravity and perpendicular to the direction of impact shall be within the range of 0.008 to 0.012 kgm<sup>2</sup>. The centre of gravity of the headform impactor including instrumentation shall be located in the geometric centre of the sphere with a tolerance of <math>\pm 2</math> mm.</p> <p>The sphere shall be covered with a <math>14 \pm 0.5</math> mm thick synthetic skin, which shall cover at least half of the sphere.</p>  | <p>"6.3.2.1. Child headform impactor (see Figure <del>14</del><b>18</b>)<br/>The child....."</p>  |
| <p>6.3.2.1.1. Child headform instrumentation</p> <p>A recess in the sphere shall allow for mounting one triaxial or three uniaxial accelerometers within <math>\pm 10</math> mm seismic mass location tolerance from the centre of the sphere for the measurement axis, and <math>\pm 1</math> mm seismic mass location tolerance from the centre of the sphere for the perpendicular direction to the measurement axis.</p> <p>If three uniaxial accelerometers are used, one of the accelerometers shall have its sensitive axis perpendicular to the mounting face A (see Figure 14) and its seismic mass shall be positioned within a cylindrical tolerance field of 1 mm radius and 20 mm length. The centre line of the tolerance field shall run perpendicular to the mounting face and its mid-point shall coincide with the centre of the sphere of the headform impactor.</p> <p>The remaining accelerometers shall have their sensitive axes perpendicular to each other and parallel to the mounting face A and their seismic mass shall be positioned within a spherical tolerance field of 10 mm radius. The centre of the tolerance field shall coin-</p> | <p><i>Paragraph 6.3.2.1.1.</i>, amend to read:<br/>"6.3.2.1.1. ... axis perpendicular to the mounting face A (see Figure <del>14</del><b>18</b>) and ..."<br/><i>Figure 14 (former)</i>, renumber as Figure 18.</p> |

side with the centre of the sphere of the headform impactor.

The instrumentation response value CFC, as defined in ISO 6487:2002, shall be 1,000. The CAC response value, as defined in ISO 6487:2002, shall be 500g for the acceleration.

6.3.2.1.2. First natural frequency

The first natural frequency of the headform impactor shall be over 5,000 Hz.

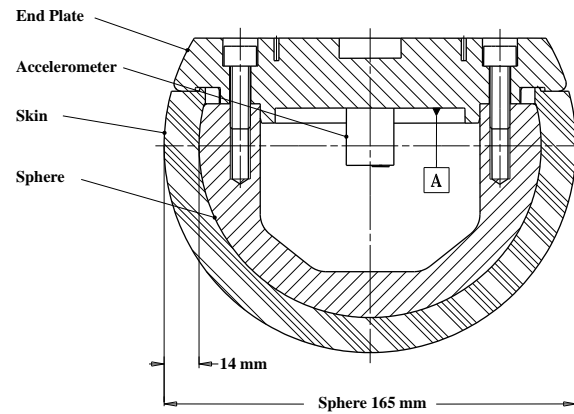


Figure 14: Child headform impactor (see paragraph 6.3.2.1.)

6.3.2.2. Adult headform impactor (see Figure 15)

The adult headform impactor shall be made of aluminium, be of

*Paragraph 6.3.2.2., amend to read:*  
"6.3.2.2. Adult headform impactor (see Figure ~~15~~**19**)  
The adult ... as shown in Figure ~~15~~**19**. The mass ..."

homogenous construction and be of spherical shape. The overall diameter is  $165 \pm 1$  mm as shown in Figure 15. The mass shall be  $4.5 \pm 0.1$  kg. The moment of inertia about an axis through the centre of gravity and perpendicular to the direction of impact shall be within the range of 0.010 to 0.013  $\text{kgm}^2$ . The centre of gravity of the headform impactor including instrumentation shall be located in the geometric centre of the sphere with a tolerance of  $\pm 5$  mm.

The sphere shall be covered with a  $14 \pm 0.5$  mm thick synthetic skin, which shall cover at least half of the sphere.

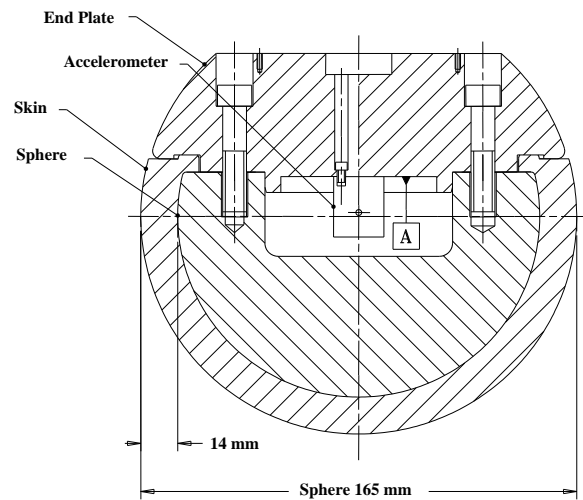


Figure 15: Adult headform impactor (see paragraph 6.3.2.2)

Figure 15 (former), renumber as Figure 19.

|  |   |
|--|---|
| <p>6.3.2.2.1. Adult headform instrumentation</p> <p>A recess in the sphere shall allow for mounting one triaxial or three uniaxial accelerometers within <math>\pm 10</math> mm seismic mass location tolerance from the centre of the sphere for the measurement axis, and <math>\pm 1</math> mm seismic mass location tolerance from the centre of the sphere for the perpendicular direction to the measurement axis.</p> <p>If three uniaxial accelerometers are used, one of the accelerometers shall have its sensitive axis perpendicular to the mounting face A (see Figure 15) and its seismic mass shall be positioned within a cylindrical tolerance field of 1 mm radius and 20 mm length. The centre line of the tolerance field shall run perpendicular to the mounting face and its mid-point shall coincide with the centre of the sphere of the headform impactor.</p> <p>The remaining accelerometers shall have their sensitive axes perpendicular to each other and parallel to the mounting face A and their seismic mass shall be positioned within a spherical tolerance field of 10 mm radius. The centre of the tolerance field shall coincide with the centre of the sphere of the headform impactor.</p> <p>The instrumentation response value CFC, as defined in ISO 6487: 2002, shall be 1,000. The CAC response value, as defined in ISO 6487: 2002, shall be 500g for the acceleration.</p> | <p><i>Paragraph 6.3.2.2.1., amend to read:</i><br/>"6.3.2.2.1. ... axis perpendicular to the mounting face A (see Figure <del>15</del><b>19</b>) and ..."<br/><i>Figure 16 (former), renumber as Figure 20.</i></p> |
| <p>6.3.2.2.2. First natural frequency</p> <p>The first natural frequency of the headform impactor shall be over 5,000 Hz.</p>  |   |
| <p>6.3.2.3. Rear face of the headform impactors</p>  |   |

|   |   |
|---|---|
| <p>A rear flat face shall be provided on the outer surface of the headform impactors which is perpendicular to the direction of travel, and typically perpendicular to the axis of one of the accelerometers as well as being a flat plate capable of providing for access to the accelerometers and an attachment point for the propulsion system.</p>   |   |
| <p>6.3.2.4. Certification of the headform impactors</p> <p>The headform impactors shall meet the performance requirements specified in paragraph 8. The certified impactors may be used for a maximum of 20 impacts before re-certification. The impactors shall be re-certified if more than one year has elapsed since the previous certification or if the transducer output, in any impact, has exceeded the specified CAC.</p> |   |
| <p>7. TEST PROCEDURES</p> <p>7.1. <u>Legform to bumper test procedures</u></p>  |   |
| <p>7.1.1. Lower legform to bumper test procedure:</p> <p>Each test shall be completed within two hours of when the impactor to be used is removed from the controlled storage area.</p>   | <p><i>Paragraphs 7.1.1. to 7.1.1.4., amend to read:</i><br/>           "7.1.1. <b>Flexible lower legform impactor</b> <del>Lower legform</del> to bumper test procedure:<br/>           Each test shall be completed within two hours of when the impactor to be used is removed from the controlled storage area."</p>   |
| <p>7.1.1.1. The selected target points shall be in the bumper test area.</p>  | <p>7.1.1.1. The selected target points shall be in the bumper test area.</p>  |
| <p>7.1.1.2. The direction of the impact velocity vector shall be in the horizontal plane and parallel to the longitudinal vertical plane of the vehicle. The tolerance for the direction of the velocity vector in the horizontal plane and in the longitudinal plane shall be <math>\pm 2^\circ</math> at the time of first contact. The axis of the impactor shall be perpendicular to the</p>                                    | <p>7.1.1.2. <b>The direction of the impact velocity vector shall be in the horizontal plane and parallel to the longitudinal vertical plane of the vehicle. The tolerance for the direction of the velocity vector in the horizontal plane and in the longitudinal plane shall be <math>\pm 2^\circ</math> at the time of first contact. The axis of the impactor shall</b></p> |

|   |  |
|---|--|
| <p>horizontal plane with a tolerance of <math>\pm 2^\circ</math> in the lateral and longitudinal plane. The horizontal, longitudinal and lateral planes are orthogonal to each other (see Figure 16).</p>   | <p><b>be perpendicular to the horizontal plane, with a roll and pitch angle tolerance of <math>\pm 2^\circ</math> in the lateral and longitudinal plane. The horizontal, longitudinal and lateral planes are orthogonal to each other (see Figure 20).</b></p> <p><del>The direction of the impact velocity vector shall be in the horizontal plane and parallel to the longitudinal vertical plane of the vehicle. The tolerance for the direction of the velocity vector in the horizontal plane and in the longitudinal plane shall be <math>\pm 2^\circ</math> at the time of first contact. The axis of the impactor shall be perpendicular to the horizontal plane with a tolerance of <math>\pm 2^\circ</math> in the lateral and longitudinal plane. The horizontal, longitudinal and lateral planes are orthogonal to each other (see Figure 16).</del></p> |
| <p>7.1.1.3. The bottom of the impactor shall be at 25 mm above ground reference plane at the time of first contact with the bumper (see Figure 17), with a <math>\pm 10</math> mm tolerance. When setting the height of the propulsion system, an allowance must be made for the influence of gravity during the period of free flight of the impactor.</p> | <p><b>7.1.1.3. The bottom of the impactor (without parts needed for the purposes of launching and/or protection) shall be 75 mm above the ground reference plane at the time of the first contact with the bumper (see Figure 21), with a tolerance of <math>\pm 10</math> mm. When setting the height of the propulsion system, an allowance must be made for the influence of gravity during the period of free flight of the impactor.</b></p> <p><del>The bottom of the impactor shall be at 25 mm above ground reference plane at the time of first contact with the bumper (see Figure 17), with a <math>\pm 10</math> mm tolerance. When setting the height of the propulsion system, an allowance must be made for the influence of gravity during the period of free flight of the impactor.</del></p>  |

|   |  |
|---|--|
| <p>7.1.1.3.1. The lower legform impactor for the bumper tests shall be in 'free flight' at the moment of impact. The impactor shall be released to free flight at such a distance from the vehicle that the test results are not influenced by contact of the impactor with the propulsion system during rebound of the impactor.</p> <p>The impactor may be propelled by an air, spring or hydraulic gun, or by other means that can be shown to give the same result.</p> | <p><b>7.1.1.3.1. The lower legform impactor for the bumper tests shall be in 'free flight' at the moment of impact. The impactor shall be released to free flight at such a distance from the vehicle that the test results are not influenced by contact of the impactor with the propulsion system during the rebound of the impactor.</b></p> <p><b>The impactor may be propelled by any means that can be shown to meet the requirements of the test.</b></p> <p><del>The lower legform impactor for the bumper tests shall be in 'free flight' at the moment of impact. The impactor shall be released to free flight at such a distance from the vehicle that the test results are not influenced by contact of the impactor with the propulsion system during rebound of the impactor.</del></p> <p><del>The impactor may be propelled by an air, spring or hydraulic gun, or by other means that can be shown to give the same result.</del></p> |
| <p>7.1.1.3.2. At the time of first contact the impactor shall have the intended orientation about its vertical axis, for the correct operation of its knee joint, with a tolerance of <math>\pm 5^\circ</math> (see Figure 16).</p>   | <p><b>7.1.1.3.2. At the time of first contact the impactor shall have the intended orientation about its vertical axis, for the correct operation of its knee joint, with a yaw angle tolerance of <math>\pm 5^\circ</math> (see Figure 20).</b></p> <p><del>At the time of first contact the impactor shall have the intended orientation about its vertical axis, for the correct operation of its knee joint, with a tolerance of <math>\pm 5^\circ</math> (see Figure 16).</del></p>   |
| <p>7.1.1.3.3. At the time of first contact the centre line of the impactor shall be within a <math>\pm 10</math> mm tolerance to the selected impact location.</p>  | <p>7.1.1.3.3. At the time of the first contact the centre line of the impactor shall be within a tolerance of <math>\pm 10</math> mm, in the</p>   |

...

lateral direction, to the selected impact location.

**Kommentiert [TK13]:** NTSEL proposes to consider the outcome of the discussion on the headform impact: This then should either refer to the measuring point or to the first point of contact

7.1.1.3.4. During contact between the impactor and the vehicle, the impactor shall not contact the ground or any object which is not part of the vehicle.

7.1.1.3.4. During the contact between the impactor and the vehicle, the impactor shall not contact the ground or any object which is not part of the vehicle.

7.1.1.4. The impact velocity of the impactor when striking the bumper shall be  $11.1 \pm 0.2$  m/s. The effect of gravity shall be taken into account when the impact velocity is obtained from measurements taken before the time of first contact.

7.1.1.4. The impact velocity of the impactor when striking the bumper shall be  $11.1 \pm 0.2$  m/s. The effect of gravity shall be taken into account when the impact velocity is obtained from measurements taken before the time of first contact."

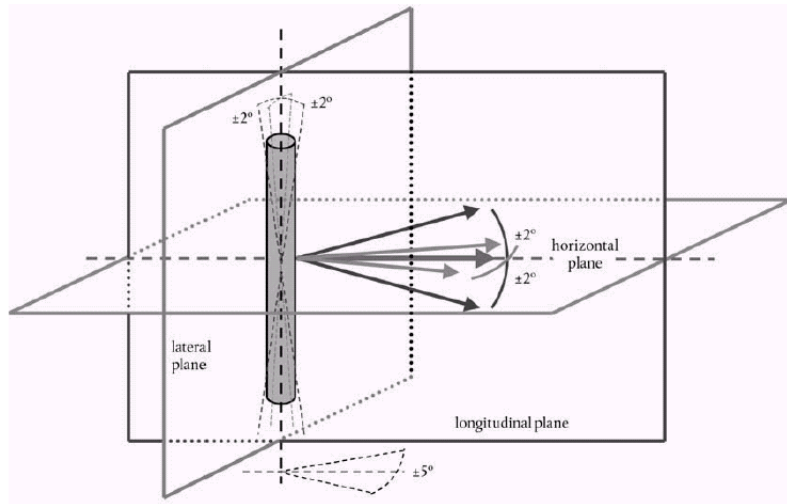


Figure 16: Tolerances of angles for the lower legform impactor at the time of the first impact (see paragraphs 7.1.1.2 and 7.1.1.3.2.)



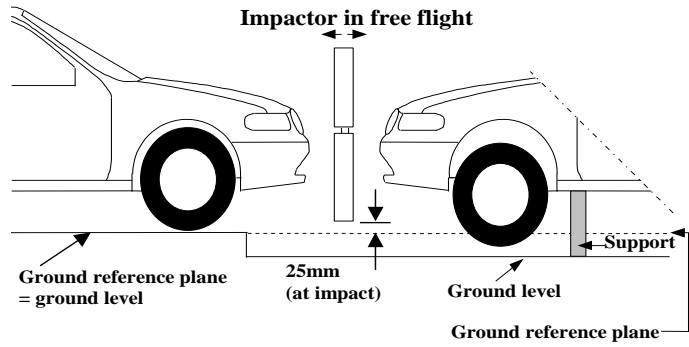
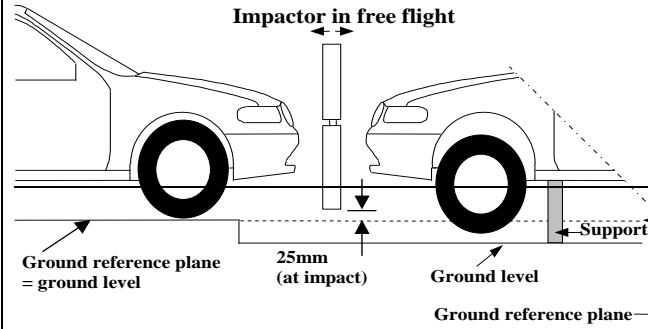


Figure 17: Lower legform to bumper tests for complete vehicle in normal ride attitude (left) and for cut-body mounted on supports (right) (see paragraph 7.1.1.3)

Figures 17(former), renumber as Figure 21 and amend to read:

"



...

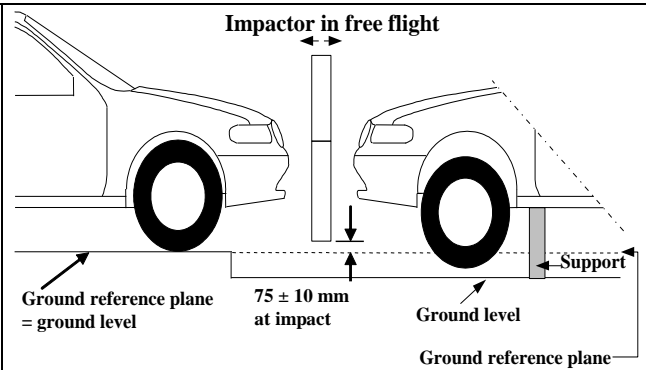


Figure 47 21: **Flexible lower legform impactor** Lower legform to bumper tests for complete vehicle in normal ride attitude (left) and for cut-body mounted on supports (right) (see paragraph 7.1.1.3.) "

*Insert a new paragraph 7.1.1.5., to read:*

**7.1.1.5 The tibia bending moments shall be  $\pm 15$  Nm within an evaluation interval of 30 ms immediately prior to impact.**

*Insert a new paragraph 7.1.1.6., to read:*

**7.1.1.6 The offset compensation shall be done with the flexible lower legform impactor in resting position prior to the test / acceleration phase."**

7.1.2. Upper legform to bumper test procedure:  
  
Each test shall be completed within two hours of when the impactor to be used is removed from the controlled storage area.

|   |  |
|---|--|
| <p>7.1.2.1. The selected target points shall be in the bumper test area as defined in paragraph 3.10.</p>   |  |
| <p>7.1.2.2. The direction of impact shall be parallel to the longitudinal axis of the vehicle, with the axis of the upper legform vertical at the time of first contact. The tolerance to this direction is <math>\pm 2^\circ</math>.</p> <p>At the time of first contact the impactor centre line shall be vertically midway between the upper bumper reference line and the lower bumper reference line with a <math>\pm 10</math> mm tolerance and the impactor vertical centre line shall be positioned laterally with the selected impact location with a tolerance of <math>\pm 10</math> mm.</p> |  |
| <p>7.1.2.3. The impact velocity of the upper legform impactor when striking the bumper shall be <math>11.1 \pm 0.2</math> m/s.</p>  |  |
| <p>7.2. <u>Headform test procedures</u></p>   |  |
| <p>7.2.1. Propulsion of the headform impactors</p> <p>The headform impactors shall be in "free flight" at the moment of impact, at the required impact velocity (as specified in paragraphs 7.3.4. and 7.4.4.) and the required direction of impact (as specified in paragraphs 7.3.5. and 7.4.5.).</p> <p>The impactors shall be released to "free flight" at such a distance from the vehicle that the test results are not influenced by contact of the impactor with the propulsion system during rebound of the impactor.</p>  |  |
| <p>7.2.2. Measurement of impact velocity</p> <p>The velocity of the headform impactor shall be measured at some point during the free flight before impact, in accordance with the</p>  |  |

|        |  |  |
|--------|--|--|
|        | <p>method specified in ISO 3784:1976. The accuracy of velocity measurement shall be <math>\pm 0.01</math> m/sec. The measured velocity shall be adjusted considering all factors which may affect the impactor between the point of measurement and the point of impact, in order to determine the velocity of the impactor at the time of impact. The angle of the velocity vector at the time of impact shall be calculated or measured.</p> |  |
| 7.2.3. | <p>Recording</p> <p>The acceleration time histories shall be recorded, and HIC shall be calculated. The first point of contact on the front structure of the vehicle shall be recorded. Recording of test results shall be in accordance with ISO 6487:2002.</p>   |  |
| 7.3.   | <p><u>Child headform test procedure</u></p> <p>This test procedure is applicable with respect to the requirements of paragraphs 5.2.1. and 5.2.3.</p>  |  |
| 7.3.1. | <p>Tests shall be made to the front structure within the boundaries as defined in paragraph 3.12. For tests on the rear area of the bonnet top, the headform impactor shall not contact the windscreen or A-pillar before impacting the bonnet top.</p>  |  |
| 7.3.2. | <p>No impact point shall be located so that the impactor will impact the test area with a glancing blow resulting in a more severe second impact outside the test area.</p> <p>Selected impact points on the bonnet for the child headform impactor shall be, at the time of first contact:</p> <p>(a) a minimum of 82.5 mm inside the defined side reference lines, and;</p>  |  |

|  |  |
|--|--|
| <p>(b) forward of the WAD1700 line, or, a minimum of 82.5 mm forwards of the bonnet rear reference line,<br/>- whichever is most forward at the point of measurement, and;</p> <p>(c) be rearward of the WAD1000 line, or, a minimum of 82.5 mm rearwards of the bonnet leading edge reference line,<br/>- whichever is most rearward at the point of measurement.</p> <p>These minimum distances are to be set with a flexible tape held tautly along the outer surface of the vehicle.</p> |  |
| <p>7.3.3. The point of first contact of the headform impactor shall be within a <math>\pm 10</math> mm tolerance to the selected impact point.</p>   |  |
| <p>7.3.4. The headform velocity at the time of impact shall be <math>9.7 \pm 0.2</math> m/s.</p>   |  |
| <p>7.3.5. The direction of impact shall be in the longitudinal vertical plane of the vehicle to be tested at an angle of <math>50 \pm 2^\circ</math> to the horizontal. The direction of impact of tests to the front structure shall be downward and rearward.</p>  |  |
| <p>7.4. <u>Adult headform test procedure:</u></p> <p>This test procedure is applicable with respect to the requirements of paragraphs 5.2.2. and 5.2.3.</p>  |  |
| <p>7.4.1. Tests shall be made to the front structure within the boundaries as defined in paragraph 3.1. For tests at the rear of the bonnet top, the headform impactor shall not contact the windscreen or A-pillar before impacting the bonnet top.</p>   |  |

|        |   |  |
|--------|---|--|
| 7.4.2. | <p>No impact point shall be located so that the impactor will impact the test area with a glancing blow resulting in a more severe second impact outside the test area.</p> <p>Selected impact points on the bonnet for the adult headform impactor shall be, at the time of first contact:</p> <ul style="list-style-type: none"><li>(a) a minimum of 82.5 mm inside the defined side reference lines, and;</li><li>(b) forward of the WAD2100 line, or, a minimum of 82.5 mm forward of the bonnet rear reference line, whichever is most forward at the point of measurement, and;</li><li>(c) rearward of the WAD1700 line.</li></ul> <p>These minimum distances are to be set with a flexible tape held tautly along the outer surface of the vehicle.</p> |  |
| 7.4.3. | <p>The point of first contact of the headform impactor shall be within a <math>\pm 10</math> mm tolerance to the selected impact point.</p>   |  |
| 7.4.4. | <p>The headform velocity at the time of impact shall be <math>[9.7 \pm 0.2</math> m/s].</p>   |  |
| 7.4.5. | <p>The direction of impact shall be in the longitudinal vertical plane of the paragraph of the vehicle to be tested at an angle of <math>65^\circ \pm 2^\circ</math> to the horizontal. The direction of impact of tests to the front structure shall be downward and rearward.</p>   |  |
| 8.     | <p><b>CERTIFICATION OF IMPACTORS</b></p> <p>The impactors that are used in the tests described in this gtr are required to comply with the following performance requirements.</p> <p>The requirements for the lower legform impactor are specified in</p>  |  |

|   |  |
|---|--|
| <p>paragraph 8.1., the upper legform impactor requirements are specified in paragraph 8.2. and the adult and child headform impactors requirements are specified in paragraph 8.3.</p>  |  |
| <p>8.1. <u>Lower legform impactor certification</u></p> <p>8.1.1. Static tests</p>  | <p><i>Paragraphs 8.1. to 8.1.3.4.4., to read:</i></p> <p>"8.1. <b>Flexible lower legform impactor</b> <del>Lower legform impactor</del> certification</p> <p>8.1.1. Static <b>certification</b> tests</p>  |
| <p>8.1.1.1. The lower legform impactor shall meet the requirements specified in paragraph 8.1.1.2. when tested as specified in paragraph 8.1.1.4. and the requirements specified in paragraph 8.1.1.3. when tested as specified in paragraph 8.1.1.5.</p> <p>For both tests the impactor shall have the intended orientation about its longitudinal axis, for the correct operation of its knee joint, with a tolerance of <math>\pm 2^\circ</math>.</p> <p>The stabilized temperature of the impactor during certification shall be <math>20^\circ \pm 2^\circ\text{C}</math>.</p> <p>The CAC response values, as defined in ISO 6487:2002 shall be <math>50^\circ</math> for the knee bending angle and 500 N for the applied force when the impactor is loaded in bending in accordance with paragraph 8.1.1.4., and 10 mm for the shearing displacement and 10 kN for the applied force when the impactor is loaded in shearing in accordance with paragraph 8.1.1.5. For both tests low-pass filtering at an appropriate frequency is permitted, to remove higher frequency noise without significantly affecting the measurement of the response of the impactor.</p> | <p>8.1.1.1. <b>The femur and the tibia of the flexible lower legform impactor shall meet the requirements specified in paragraph 8.1.1.2 when tested according to paragraph 8.1.1.4. The knee joint of the lower legform impactor shall meet the requirements specified in paragraph 8.1.1.3 when tested according to paragraph 8.1.1.5. The stabilized temperature of the impactor during the certification tests shall be <math>20^\circ \pm 2^\circ\text{C}</math>.</b></p> <p><b>The CAC response values, as defined in ISO 6487:2002, shall be 30 mm for the knee ligament elongations and 4 kN for the applied external load. For these tests, low-pass filtering at an appropriate frequency is permitted to remove higher frequency noise without significantly affecting the measurement of the response of the impactor.</b></p> <p><del>The lower legform impactor shall meet the requirements specified in paragraph 8.1.1.2. when tested as specified in paragraph 8.1.1.4. and the requirements specified in paragraph 8.1.1.3. when</del></p> |

|  |   |
|--|---|
|  | <p>tested as specified in paragraph 8.1.1.5.</p> <p><del>For both tests the impactor shall have the intended orientation about its longitudinal axis, for the correct operation of its knee joint, with a tolerance of <math>\pm 2^\circ</math>.</del></p> <p><del>The stabilized temperature of the impactor during certification shall be <math>20^\circ \pm 2^\circ\text{C}</math>.</del></p> <p><del>The CAC response values, as defined in ISO 6487:2002 shall be <math>50^\circ</math> for the knee bending angle and 500 N for the applied force when the impactor is loaded in bending in accordance with paragraph 8.1.1.4., and 10 mm for the shearing displacement and 10 kN for the applied force when the impactor is loaded in shearing in accordance with paragraph 8.1.1.5. For both tests low pass filtering at an appropriate frequency is permitted, to remove higher frequency noise without significantly affecting the measurement of the response of the impactor.</del></p> |
| <p>8.1.1.2. When the impactor is loaded in bending in accordance with paragraph 8.1.1.4., the applied force/bending angle response shall be within the limits shown in Figure 18. Also, the energy taken to generate <math>15.0^\circ</math> of bending shall be <math>100 \pm 7 \text{ J}</math>.</p> | <p>8.1.1.2. <b>When the femur and the tibia of the impactor are loaded in bending in accordance with paragraph 8.1.1.4., the applied moment and the generated deflection at the centre of the femur and the tibia (<math>M_c</math> and <math>D_c</math>) shall be within the corridors shown in Figure 22.</b></p> <p><del>When the impactor is loaded in bending in accordance with paragraph 8.1.1.4., the applied force/bending angle response shall be within the limits shown in Figure 18. Also, the energy taken to generate <math>15.0^\circ</math> of bending shall be <math>100 \pm 7 \text{ J}</math>.</del></p>  |



|   |   |
|---|---|
| <p>8.1.1.3. When the impactor is loaded in shearing in accordance with paragraph 8.1.1.5., the applied force/shearing displacement response shall be within the limits shown in Figure 19.</p>  | <p><b>8.1.1.3. When the knee joint of the impactor is loaded in bending in accordance with paragraph 8.1.1.5., the MCL, ACL, and PCL elongations and applied bending moment or the force at the centre of the knee joint (<math>M_c</math> or <math>F_c</math>) shall be within the corridors shown in Figure 23.</b></p> <p><del>When the impactor is loaded in shearing in accordance with paragraph 8.1.1.5., the applied force/shearing displacement response shall be within the limits shown in Figure 19.</del></p>  |
| <p>8.1.1.4. The impactor, without foam covering and skin, shall be mounted with the tibia firmly clamped to a fixed horizontal surface and a metal tube connected firmly to the femur, as shown in Figure 20. The rotational axis of the impactor knee joint shall be vertical. To avoid friction errors, no support shall be provided to the femur section or the metal tube. The bending moment applied at the centre of the knee joint, due to the mass of the metal tube and other components (excluding the legform itself), shall not exceed 25 Nm.</p> <p>A horizontal normal force shall be applied to the metal tube at a distance of <math>2.0 \pm 0.01</math> m from the centre of the knee joint and the resulting angle of knee deflection shall be recorded. The load shall be increased at a rate between 1.0 and <math>10^\circ/s</math> until the angle of deflection of the knee is in excess of <math>22^\circ</math>. Brief excursions from these limits due, for instance, to the use of a hand-pump shall be permitted.</p> <p>The energy is calculated by integrating the force with respect to the bending angle in radians, and multiplying by the lever length of 2.0</p> | <p><b>8.1.1.4. The edges of the femur and tibia, not bending parts, shall be mounted to the support rig firmly as shown in Figure 24 and Figure 25. The Y-axis of the impactor shall be parallel to the loading axis within <math>180 \pm 2^\circ</math> tolerance. In order to avoid friction errors, roller plates shall be set underneath the support rigs.</b></p> <p><b>The centre of the loading force shall be applied at the centre of the femur and the tibia within <math>\pm 2^\circ</math> tolerance along the Z-axis. The force shall be increased at a rate between 10 and 100 mm/minute until the bending moment at the centre part (<math>M_c</math>) of the femur or tibia reaches 400 Nm.</b></p> <p><del>The impactor, without foam covering and skin, shall be mounted with the tibia firmly clamped to a fixed horizontal surface and a metal tube connected firmly to the femur, as shown in Figure 20. The rotational axis of impactor knee joint shall be vertical. To avoid friction</del></p> |

|  |  |
|--|--|
| <p><math>\pm 0.01</math> m.</p>  | <p><del>errors, no support shall be provided to the femur section or the metal tube. The bending moment applied at the centre of the knee joint, due to the mass of the metal tube and other components (excluding the legform itself), shall not exceed 25 Nm.</del></p> <p><del>A horizontal normal force shall be applied to the metal tube at a distance of 2.0 <math>\pm</math> 0.01 m from the centre of the knee joint and the resulting angle of knee deflection shall be recorded. The load shall be increased at a rate between 1.0 and 10°/s until the angle of deflection of the knee is in excess of 22°. Brief excursions from these limits due, for instance, to the use of a hand-pump shall be permitted.</del></p> <p><del>The energy is calculated by integrating the force with respect to the bending angle in radians, and multiplying by the lever length of 2.0 <math>\pm</math> 0.01 m.</del></p> |
| <p>8.1.1.5. The impactor, without foam covering and skin, shall be mounted with the tibia firmly clamped to a fixed horizontal surface and a metal tube connected firmly to the femur and restrained at 2.0 m from the centre of the knee joint, as shown in Figure 21.</p> <p>A horizontal normal force shall be applied to the femur at a distance of 50 mm from the centre of the knee joint and the resulting knee shearing displacement shall be recorded. The load shall be increased at a rate between 0.1 and 20 mm/s until the shearing displacement of the knee is in excess of 7.0 mm or the load is in excess of 6.0 kN. Brief excursions from these limits due, for instance, to the use of a hand-pump shall be permitted.</p> | <p>8.1.1.5. <b>The edges of the knee joint shall be mounted to the support rig firmly as shown in Figure 26. The Y-axis of the impactor shall be parallel to the loading axis within <math>\pm 2^\circ</math> tolerance. In order to avoid friction errors, roller plates shall be set underneath the support rigs. To avoid impactor damage, a neoprene sheet shall be set underneath the loading ram and the impactor face of the knee joint which is described in the Figure 13 shall be removed. The neoprene sheet used in this test shall have compression characteristics as shown in Figure 15.</b></p> <p><b>The centre of the loading force shall be applied at the centre of the knee joint within <math>\pm 2^\circ</math> tolerance</b></p>   |

|  |  |
|--|--|
|  | <p><b>along the Z-axis. The external load shall be increased at a rate between 10 and 100 mm/minute until the bending moment at the centre part of the knee joint (<math>M_c</math>) reaches 400 Nm.</b></p> <p><del>The impactor, without foam covering and skin, shall be mounted with the tibia firmly clamped to a fixed horizontal surface and a metal tube connected firmly to the femur and restrained at 2.0 m from the centre of the knee joint, as shown in Figure 21.</del></p> <p><del>A horizontal normal force shall be applied to the femur at a distance of 50 mm from the centre of the knee joint and the resulting knee shearing displacement shall be recorded. The load shall be increased between 0.1 and 20 mm/s until the shearing displacement of the knee is in excess of 7.0 mm or the load is in excess of 6.0 kN. Brief excursions from these limits due, for instance, to the use of a hand pump shall be permitted.</del></p> |
| <p>8.1.2. Dynamic tests</p> <p>8.1.2.1. The lower legform impactor shall meet the requirements specified in paragraph 8.1.2.3. when tested as specified in paragraph 8.1.2.4.</p>  | <p>8.1.2. Dynamic <b>certification</b> tests (<b>pendulum test</b>)</p> <p>8.1.2.1. The assembled <b>flexible lower legform impactor</b> <del>lower legform impactor</del> shall meet the requirements according to paragraph 8.1.2.3 when tested as specified in paragraph 8.1.2.4.</p>   |
| <p>8.1.2.2. Calibration</p> <p>8.1.2.2.1. The foam flesh for the test impactor shall be stored for a period of at least four hours in a controlled storage area with a stabilized humidity of <math>35 \pm 10</math> percent and a stabilized temperature of <math>20 \pm 2^\circ\text{C}</math> prior</p> | <p>8.1.2.2. Certification</p> <p>8.1.2.2.1. <b>The test facility used for the certification test shall have a stabilized temperature of <math>20 \pm 2^\circ\text{C}</math> during</b></p>   |

...

|  |   |
|--|---|
| <p>to impactor removal for calibration. The test impactor itself shall have a temperature of <math>20^{\circ} \pm 2^{\circ}\text{C}</math> at the time of impact. The temperature tolerances for the test impactor shall apply at a relative humidity of <math>40 \pm 30</math> percent after a soak period of at least four hours prior to their application in a test.</p> | <p><b>the test.</b></p> <p><del>The foam flesh for the test impactor shall be stored during a period of at least four hours in a controlled storage area with a stabilized humidity of <math>35 \pm 10</math> percent and a stabilized temperature of <math>20 \pm 2^{\circ}\text{C}</math> prior to impactor removal for calibration. The test impactor itself shall have a temperature of <math>20^{\circ} \pm 2^{\circ}\text{C}</math> at the time of impact. The temperature tolerances for the test impactor shall apply at a relative humidity of <math>40 \pm 30</math> percent after a soak period of at least four hours prior to their application in a test.</del></p> |
| <p>8.1.2.2.2. The test facility used for the calibration test shall have a stabilized humidity of <math>40 \pm 30</math> percent and a stabilized temperature of <math>20 \pm 4^{\circ}\text{C}</math> during calibration.</p>   | <p><b>8.1.2.2.2. The temperature of the certification area shall be measured at the time of certification and recorded in a certification report.</b></p> <p><del>The test facility used for the calibration test shall have a stabilized humidity of <math>40 \pm 30</math> percent and a stabilized temperature of <math>20 \pm 4^{\circ}\text{C}</math> during calibration.</del></p>  |
| <p>8.1.2.2.3. Each calibration shall be completed within two hours of when the impactor to be calibrated is removed from the controlled storage area.</p>  | <p><del>8.1.2.2.3. Each calibration shall be completed within two hours of when the impactor to be calibrated is removed from the controlled storage area.</del></p>  |
| <p>8.1.2.2.4. The relative humidity and temperature of the calibration area shall be measured at the time of calibration and recorded in the calibration report.</p>   | <p><del>8.1.2.2.4. Relative humidity and temperature of the calibration area shall be measured at the time of calibration and recorded in a calibration report.</del></p>   |
| <p>8.1.2.3. Requirements</p>   | <p>8.1.2.3. Requirements</p>  |

|   |   |
|---|---|
| <p>8.1.2.3.1. When the impactor is impacted by a linearly guided certification impactor, as specified in paragraph 8.1.2.4., the maximum upper tibia acceleration shall be not less than 120g and not more than 250g. The maximum bending angle shall be not less than 6.2° and not more than 8.2°. The maximum shearing displacement shall be not less than 3.5 mm and not more than 6.0 mm.</p> <p>For all these values, the readings used shall be from the initial impact with the certification impactor and not from the arresting phase. Any system used to arrest the impactor or certification impactor shall be so arranged that the arresting phase does not overlap in time with the initial impact. The arresting system shall not cause the transducer outputs to exceed the specified CAC.</p> | <p><b>8.1.2.3.1. When the flexible lower legform impactor is used for a test according to paragraph 8.1.2.4., the absolute value of the maximum bending moment of the tibia at tibia-1 shall be not more than 272 Nm and not less than 235 Nm, the absolute value of the maximum bending moment at tibia-2 shall be not more than 219 Nm and not less than 187 Nm, the absolute value of the maximum bending moment at tibia-3 shall be not more than 166 Nm and not less than 139 Nm, and the absolute value of the maximum bending moment at tibia-4 shall be not more than 111 Nm and not less than 90 Nm. The absolute value of the maximum elongation of MCL shall be not more than 24.0 mm and not less than 20.5 mm, the absolute value of the maximum elongation of ACL shall be not more than 10.5 mm and not less than 8.0 mm, and the absolute value of the maximum elongation of PCL shall be not more than 5.0 mm and not less than 3.5 mm.</b></p> <p><b>For all these values, the readings used shall be from the initial impact timing to 200 ms after the impact timing.</b></p> <p><del>When the impactor is impacted by a linearly guided certification impactor, as specified in paragraph 8.1.2.4., the maximum upper tibia acceleration shall be not less than 120g and not more than 250g. The maximum bending angle shall be not less than 6.2° and not more than 8.2°. The maximum shearing displacement shall be not less than 3.5 mm and not more than 6.0 mm.</del></p> <p><del>For all these values, the readings used shall be from the</del></p> |
|---|---|

|   |  |
|---|--|
|   | <p><del>initial impact with the certification impactor and not from the arresting phase. Any system used to arrest the impactor or certification impactor shall be so arranged that the arresting phase does not overlap in time with the initial impact. The arresting system shall not cause the transducer outputs to exceed the specified CAC.</del></p>   |
| <p>8.1.2.3.2. The instrumentation response value CFC, as defined in ISO 6487:2002, shall be 180 for all transducers. The CAC response values, as defined in ISO 6487:2002, shall be 50° for the knee bending angle, 10 mm for the shearing displacement and 500g for the acceleration. This does not require that the impactor itself be able to physically bend and shear to these angles and displacements.</p>   | <p><b>8.1.2.3.2. The instrumentation response value CFC, as defined in ISO 6487:2002, shall be 180 for all transducers. The CAC response values, as defined in ISO 6487:2002, shall be 30 mm for the knee ligament elongations and 400 Nm for the tibia bending moments.</b></p> <p><del>The instrumentation response value CFC, as defined in ISO 6487:2002, shall be 180 for all transducers. The CAC response values, as defined in ISO 6487:2002, shall be 50° for the knee bending angle, 10 mm for the shearing displacement and 500g for the acceleration. This does not require that the impactor itself be able to physically bend and shear to these angles and displacements.</del></p> |
| <p>8.1.2.4. Test procedure</p> <p>8.1.2.4.1. The impactor, including foam covering and skin, shall be suspended horizontally by three wire ropes of 1.5 ± 0.2 mm diameter and of 2000 mm minimum length, as shown in Figure 22. It shall be suspended with its longitudinal axis horizontal, with a tolerance of ± 0.5°, and perpendicular to the direction of the certification impactor motion, with a tolerance of ± 2°. The impactor shall have the in-</p> | <p>8.1.2.4. Test procedure</p> <p><b>8.1.2.4.1. The flexible lower legform impactor, including the flesh and skin, shall be suspended from the dynamic certification test rig 15 ± 1° upward from the horizontal as shown in Figure 27. The impactor shall be released from the suspended position and falls freely against the pin joint of the test rig as</b></p>   |

|  |  |
|--|--|
| <p>tended orientation about its longitudinal axis, for the correct operation of its knee joint, with a tolerance of <math>\pm 2^\circ</math>. The impactor must meet the requirements of paragraph 6.3.1.1., with the attachment bracket(s) for the wire ropes fitted.</p>   | <p><b>shown in Figure 27.</b></p> <p><del>The impactor, including foam covering and skin, shall be suspended horizontally by three wire ropes of <math>1.5 \pm 0.2</math> mm diameter and of 2000 mm minimum length, as shown in Figure 22. It shall be suspended with its longitudinal axis horizontal, with a tolerance of <math>\square 0.5</math>, and perpendicular to the direction of the certification impactor motion, with a tolerance of <math>\square 2</math>. The impactor shall have the intended orientation about its longitudinal axis, for the correct operation of its knee joint, with a tolerance of <math>\pm 2^\circ</math>. The impactor must meet the requirements of paragraph 6.3.1.1., with the attachment bracket(s) for the wire ropes fitted.</del></p>  |
| <p>8.1.2.4.2. The certification impactor shall have a mass of <math>9.0 \pm 0.05</math> kg, this mass includes those propulsion and guidance components which are effectively part of the impactor during impact. The dimensions of the face of the certification impactor shall be as specified in Figure 23. The face of the certification impactor shall be made of aluminium, with an outer surface finish of better than 2.0 micrometers.</p> <p>The guidance system shall be fitted with low friction guides, insensitive to off-axis loading, that allow the impactor to move only in the specified direction of impact, when in contact with the vehicle. The guides shall prevent motion in other directions including rotation about any axis.</p> | <p><b>8.1.2.4.2. The knee joint centre of the impactor shall be <math>30 \pm 1</math> mm below the bottom line of the stopper bar, and the tibia impact face without the flesh and skin shall be located <math>13 \pm 2</math> mm from the front upper edge of the stopper bar when the impactor is hanging freely as shown in Figure 27.</b></p> <p><del>The certification impactor shall have a mass of <math>9.0 \square 0.05</math> kg, this mass includes those propulsion and guidance components which are effectively part of the impactor during impact. The dimensions of the face of the certification impactor shall be as specified in Figure 23. The face of the certification impactor shall be made of aluminium, with an outer surface finish of better than 2.0 micrometers.</del></p> <p><del>The guidance system shall be fitted with low friction guides, insensitive to off axis loading, that allow the</del></p> |

|  |   |
|--|---|
|  | <p><del>impactor to move only in the specified direction of impact, when in contact with the vehicle. The guides shall prevent motion in other directions including rotation about any axis.</del></p>  |
| <p>8.1.2.4.3. The impactor shall be certified with previously unused foam.</p>   | <p><del>8.1.2.4.3. The impactor shall be certified with previously unused foam.</del></p>   |
| <p>8.1.2.4.4. The impactor foam shall not be excessively handled or deformed before, during or after fitting.</p>  | <p><del>8.1.2.4.4. The impactor foam shall not be excessively handled or deformed before, during or after fitting.</del></p>  |
| <p>8.1.2.4.5. The certification impactor shall be propelled horizontally at a velocity of <math>7.5 \pm 0.1</math> m/s into the stationary impactor as shown in Figure 23. The certification impactor shall be positioned so that its centreline aligns with a position on the tibia centreline of 50 mm from the centre of the knee, with tolerances of <math>\pm 3</math> mm laterally and <math>\pm 3</math> mm vertically.</p> | <p><del>8.1.2.4.5. The certification impactor shall be propelled horizontally at a velocity of <math>7.5 \pm 0.1</math> m/s into the stationary impactor as shown in Figure 23. The certification impactor shall be positioned so that its centreline aligns with a position on the tibia centreline of 50 mm from the centre of the knee, with tolerances of <math>\pm 3</math> mm laterally and <math>\pm 3</math> mm vertically.</del></p> |
|  | <p><b>8.1.3. Dynamic certification tests (inverse type)</b></p> <p><b>8.1.3.1. The assembled flexible lower legform impactor shall meet the requirements according to paragraph 8.1.3.3 when tested as specified in paragraph 8.1.3.4.</b></p>  |
|  | <p><b>8.1.3.2. Certification</b></p> <p><b>8.1.3.2.1. The test facility used for the certification test shall</b></p>   |



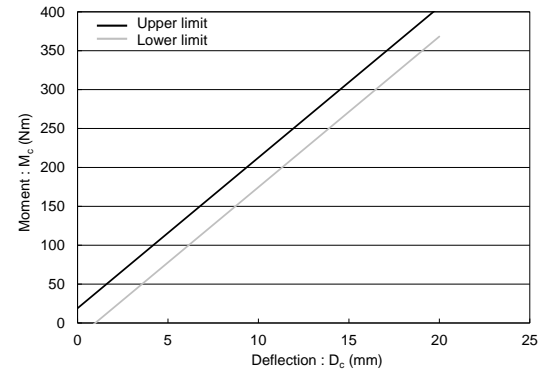
|  |  |
|--|--|
|  | <p>have a stabilized temperature of <math>20 \pm 2</math> °C during certification.</p>   |
|  | <p><b>8.1.3.2.3.</b> The temperature of the certification area shall be measured at the time of certification and recorded in a certification report.</p>  |
|  | <p><b>8.1.3.3. Requirements</b></p> <p><b>8.1.3.3.1.</b> When the flexible lower legform impactor is used for the test according to paragraph 8.1.3.4, the absolute value of the maximum bending moment of the tibia at tibia-1 shall be not more than 272 Nm and not less than 230 Nm, the absolute value of the maximum bending moment at tibia-2 shall be not more than 252 Nm and not less than 210 Nm, the absolute value of the maximum bending moment at tibia-3 shall be not more than 192 Nm and not less than 166 Nm, and the absolute value of the maximum bending moment at tibia-4 shall be not more than 108 Nm and not less than 93 Nm. The absolute value of the maximum elongations of the MCL shall be not more than 21.0 mm and not less than 17.0 mm, of the ACL shall be not more than 10.0 mm and not less than 8.0 mm and of the PCL shall be not more than 6.0 mm and not less than 4.0 mm.</p> <p>For all these values, the readings used shall be from the initial impact timing to 50 ms after the impact timing.</p> |

...

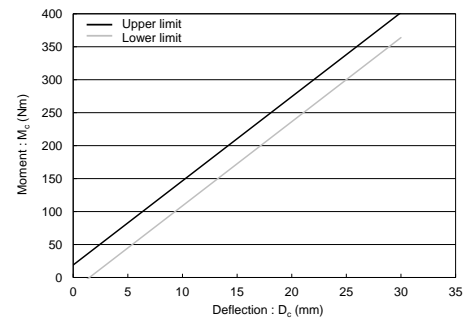
|  |  |
|--|--|
|  |  |
|  | <p><b>8.1.3.3.2. The instrumentation response value CFC, as defined in ISO 6487:2002, shall be 180 for all transducers. The CAC response values, as defined in ISO 6487:2002, shall be 30 mm for the knee ligament elongations and 400 Nm for the tibia bending moments.</b></p>   |
|  | <p><b>8.1.3.4. Test procedure</b></p> <p><b>8.1.3.4.1. The assembled flexible lower legform impactor (with the flesh and skin) shall be hung vertically and freely suspended from a test rig as shown in Figure 28. It is then impacted by the upper edge of a linearly guided Aluminium honeycomb impactor, covered by a thin paper cloth with a maximum thickness of 1 mm, at an impact speed of <math>11.1 \pm 0.2</math> m/s. The legform shall achieve a free flight condition 10 ms after the time of first contact of the honeycomb impactor.</b></p> |
|  | <p><b>8.1.3.4.2. The honeycomb of 5052 alloy, which is attached in front of the moving ram, shall be <math>200 \pm 5</math> mm wide, <math>160 \pm 5</math> mm high and <math>60 \pm 2</math> mm deep and shall have a crush strength of <math>75 \text{ psi} \pm 10</math> percent. The honeycomb should have cell sizes of either 3/16 inch or 1/4 inch and a density of 2.0 pcf for the 3/16 inch cell size or a density of 2.3 pcf for the 1/4 inch cell size.</b></p>   |

|  |  |
|--|--|
|  | <p><b>8.1.3.4.3. The upper edge of the honeycomb face shall be in line with the rigid plate of the linearly guided impactor. At the time of first contact, the upper edge of the honeycomb shall be in line with the knee joint centre line within a vertical tolerance of <math>\pm 2</math> mm. The honeycomb shall not be deformed before the impact test.</b></p>  |
|  | <p><b>8.1.3.4.4. At the time of the first contact, the flexible lower legform impactor pitch angle (rotation around the Y-axis) and therefore the pitch angle of the velocity vector of the honeycomb impactor shall be within a tolerance of <math>\pm 2^\circ</math> in relation to the lateral vertical plane. The flexible lower legform impactor roll angle (rotation around the X-axis) and therefore the roll angle of the honeycomb impactor shall be within a tolerance of <math>\pm 2^\circ</math> in relation to the longitudinal vertical plane. The flexible lower legform impactor yaw angle (rotation around the Z-axis) and therefore the yaw angle of the velocity vector of the honeycomb impactor shall be within a tolerance of <math>\pm 2^\circ</math>."</b></p> |
|  |  |
|  | <p><i>Insert new Figures 22 to 28., to read:</i></p> <p>"</p>  |

...

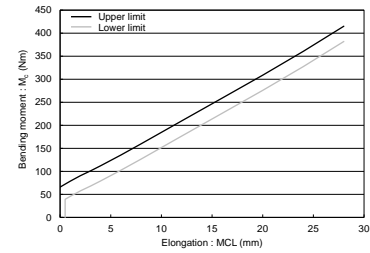


(a) Femur bending corridor

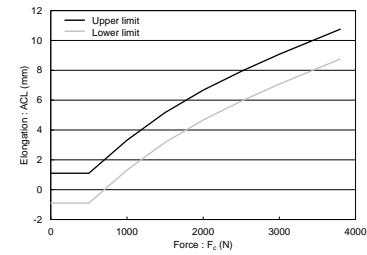


(b) Tibia bending corridor

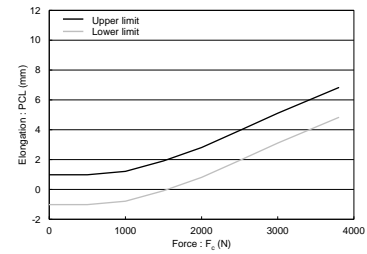
**Figure 22: Flexible lower legform impactor: Requirement corridors of the femur and the tibia in the static certification test (see paragraph 8.1.1.2.)**



(a) for MCL



(b) for ACL

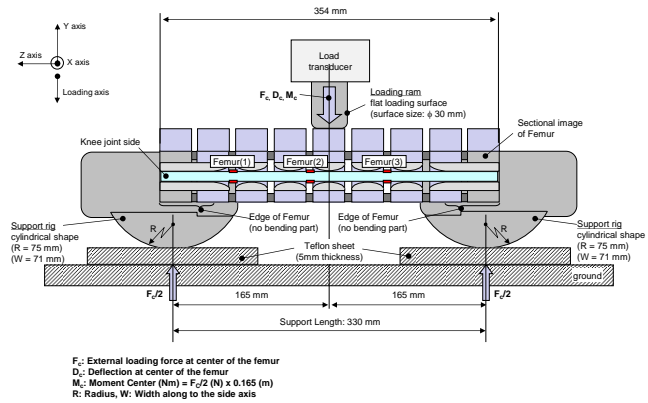


(c) for PCL

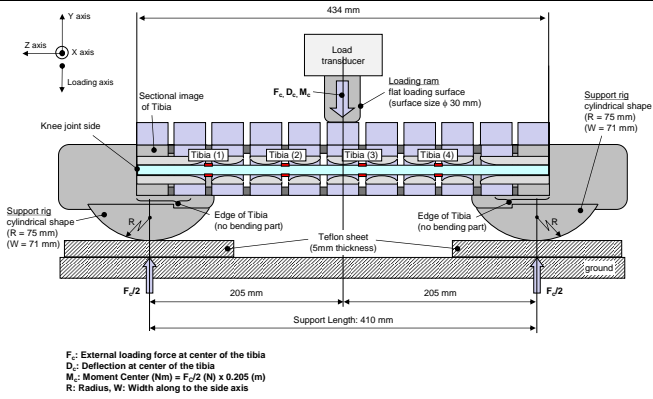
**Figure 23: Flexible lower legform impactor: Requirement**

...

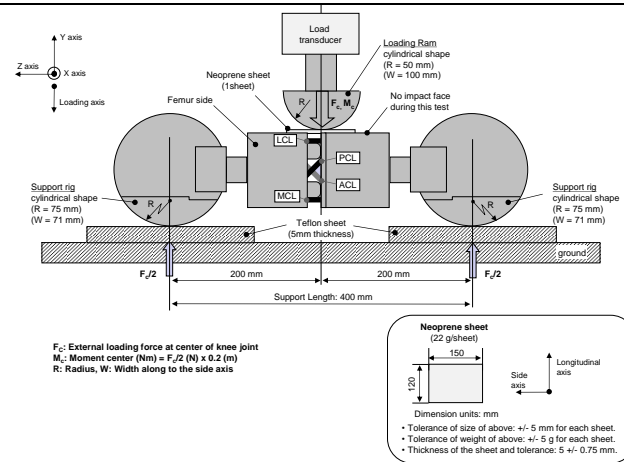
**corridors for the knee joint in the static certification test  
(see paragraph 8.1.1.3.)**



**Figure 24: Flexible lower legform: Impactor test  
set-up for the femur in the static certification test  
(see paragraph 8.1.1.4.)**

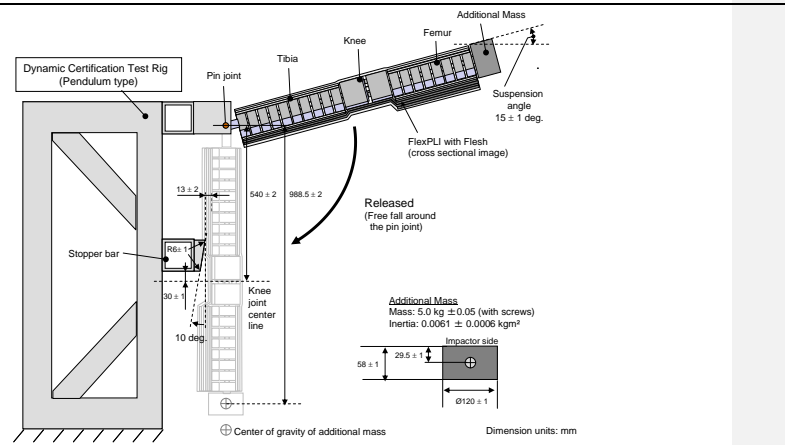


**Figure 25: Flexible lower legform impactor: Test set-up for the tibia in the static certification test (see paragraph 8.1.1.4.)**

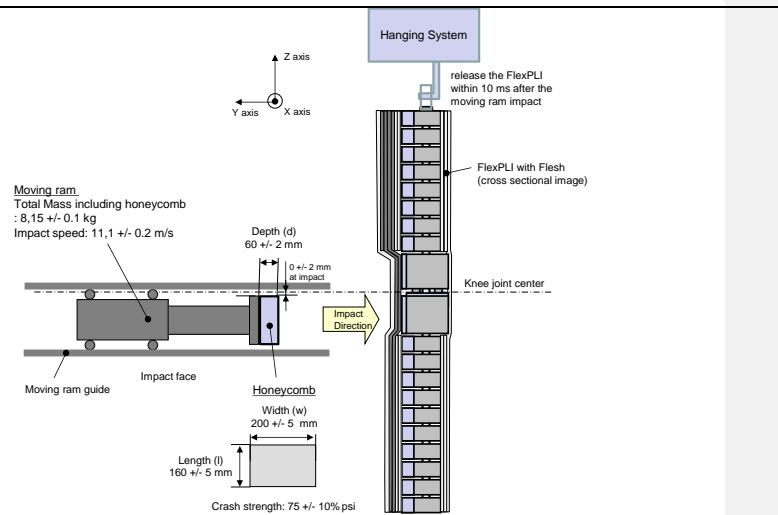


**Figure 26: Flexible lower legform impactor: Test set-up for the knee joint in the static certification test (see paragraph 8.1.1.5.)**





**Figure 27: Flexible lower legform impactor: Test set-up for the dynamic lower legform impactor certification test (pendulum test, see paragraph 8.1.2.4.)**



**Figure 28:** Flexible lower legform impactor: Test set-up for the dynamic lower legform impactor certification test (inverse test, see paragraph 8.1.3.4.)

**Kommentiert [TK14]:** The figure needs to say „FlexPLI with flesh and skin“ for the impactor. For the honeycomb cell, it should say “width” and “height” and needs to mention the paper cover (max. 1 mm thick).

|  |  |
|--|--|
| <p>8.2. <u>Upper legform impactor certification</u></p> <p>8.2.1. The upper legform impactor shall meet the requirements specified in paragraph 8.2.3. when tested as specified in paragraph 8.2.4.</p>  |  |
| <p>8.2.2. Calibration</p> <p>8.2.2.1. The foam flesh for the test impactor shall be stored for a period of at least four hours in a controlled storage area with a stabilized humidity of <math>35 \pm 10</math> percent and a stabilized temperature of <math>20^\circ \pm 2^\circ\text{C}</math> prior to impactor removal for calibration. The test impactor itself shall have a temperature of <math>20^\circ \pm 2^\circ\text{C}</math> at the time of impact. The temperature tolerances for the test impactor shall apply at a relative humidity of <math>40 \pm 30</math> percent after a soak period of at least four hours prior to their application in a test.</p> |  |
| <p>8.2.2.2. The test facility used for the calibration test shall have a stabilized humidity of <math>40 \pm 30</math> percent and a stabilized temperature of <math>20^\circ \pm 4^\circ\text{C}</math> during calibration.</p>   |  |
| <p>8.2.2.3. Each calibration shall be completed within two hours of when the impactor to be calibrated is removed from the controlled storage area.</p>  |  |
| <p>8.2.2.4. The relative humidity and temperature of the calibration area shall be measured at the time of calibration, and recorded in the calibration report.</p>  |  |
| <p>8.2.3. Requirements</p> <p>8.2.3.1. When the impactor is propelled into a stationary cylindrical pendulum the peak force measured in each load transducer shall be not less than 1.20 kN and not more than 1.55 kN and the difference be-</p>   |  |

|   |  |
|---|--|
| <p>tween the peak forces measured in the top and bottom load transducers shall not be more than 0.10 kN. Also, the peak bending moment measured by the strain gauges shall not be less than 190 Nm and not more than 250 Nm on the centre position and not less than 160 Nm and not more than 220 Nm for the outer positions. The difference between the upper and lower peak bending moments shall not be more than 20 Nm.</p> <p>For all these values, the readings used shall be from the initial impact with the pendulum and not from the arresting phase. Any system used to arrest the impactor or pendulum shall be so arranged that the arresting phase does not overlap in time with the initial impact. The arresting system shall not cause the transducer outputs to exceed the specified CAC.</p> |  |
| <p>8.2.3.2. The instrumentation response value CFC, as defined in ISO 6487:2002, shall be 180 for all transducers. The CAC response values, as defined in ISO 6487:2002, shall be 10 kN for the force transducers and 1000 Nm for the bending moment measurements.</p>  |  |
| <p>8.2.4. Test procedure</p> <p>8.2.4.1. The impactor shall be mounted to the propulsion and guidance system, by a torque limiting joint. The torque limiting joint shall be set so that the longitudinal axis of the front member is perpendicular to the axis of the guidance system, with a tolerance of <math>\pm 2^\circ</math>, with the joint friction torque set to <math>675 \pm 25</math> Nm. The guidance system shall be fitted with low friction guides that allow the impactor to move only in the specified direction of impact, when in contact with the pendulum.</p>  |  |
| <p>8.2.4.2. The impactor mass shall be adjusted to give a mass of <math>12 \pm 0.1</math> kg, this mass includes those propulsion and guidance components</p>   |  |

|          |   |
|----------|---|
|          | which are effectively part of the impactor during impact.   |
| 8.2.4.3. | The centre of gravity of those parts of the impactor which are effectively forward of the torque limiting joint, including the extra masses fitted, shall lie on the longitudinal centreline of the impactor, with a tolerance of $\pm 10$ mm.  |
| 8.2.4.4. | The impactor shall be certified with previously unused foam.  |
| 8.2.4.5. | The impactor foam shall not be excessively handled or deformed before, during or after fitting.   |
| 8.2.4.6. | <p>The impactor with the front member vertical shall be propelled horizontally at a velocity of <math>7.1 \pm 0.1</math> m/s into the stationary pendulum as shown in Figure 24.</p> <p><i>Paragraph 8.2.4.6., amend to read:</i></p> <p style="text-align: center;">"... at a velocity of <math>7.1 \pm 0.1</math> m/s into the stationary pendulum as shown in Figure <del>24</del><b>29</b>."</p>  |
| 8.2.4.7. | <p>The pendulum tube shall have a mass of <math>3 \pm 0.03</math> kg, a wall thickness of <math>3 \pm 0.15</math> mm and an outside diameter of <math>150 \text{ mm}^{+1 \text{ mm}/_4 \text{ mm}}</math>. Total pendulum tube length shall be <math>275 \pm 25</math> mm. The pendulum tube shall be made from cold finished seamless steel (metal surface plating is permissible for protection from corrosion), with an outer surface finish of better than 2.0 micrometer. It shall be suspended on two wire ropes of <math>1.5 \pm 0.2</math> mm diameter and of 2.0 m minimum length. The surface of the pendulum shall be clean and dry. The pendulum tube shall be positioned so that the longitudinal axis of the cylinder is perpendicular to the front member (i.e. level), with a tolerance of <math>\pm 2^\circ</math>, and to the direction of impactor motion, with a tolerance of <math>\pm 2^\circ</math>, and with the centre of the pendulum tube aligned with the centre of the impactor front member, with tolerances of <math>\pm 5</math> mm laterally and <math>\pm 5</math> mm vertically.</p> |

|          |   |  |
|----------|---|--|
| 8.3.     | <u>Child and adult headform impactors certification</u>   |  |
| 8.3.1.   | Drop test   |  |
| 8.3.1.1. | Performance criteria<br><br>The headform impactors shall meet the requirements specified in paragraph 8.3.2. when tested as specified in paragraph 8.3.3.   |  |
| 8.3.2.   | Requirements  |  |
| 8.3.2.1. | When the headform impactors are dropped from a height of $376 \pm 1$ mm in accordance with paragraph 8.3.3. the peak resultant acceleration measured by one triaxial (or three uniaxial) accelerometer (accelerometers) in the headform impactor shall be:<br>(a) for the child headform impactor not less than 245g and not more than 300g;<br>(b) for the adult headform impactor not less than 225g and not more than 275g.<br>The acceleration time curve shall be uni-modal. |  |
| 8.3.2.2. | The instrumentation response values CFC and CAC for each accelerometer shall be 1,000 Hz and 500g respectively as defined in ISO 6487:2002.   |  |
| 8.3.2.3. | Temperature conditions<br><br>The headform impactors shall have a temperature of $20 \pm 2^{\circ}\text{C}$ at the time of impact. The temperature tolerances shall apply at a relative humidity of $40 \pm 30$ percent after a soak period of at least four hours prior to their application in a test.  |  |

|  |  |
|--|--|
| <p>8.3.2.4. After complying with the certification test, each headform impactor can be used for a maximum of 20 impact tests.</p>  |  |
| <p>8.3.3. Test procedure</p> <p>8.3.3.1. The headform impactor shall be suspended from a drop rig as shown in Figure 25.</p>   | <p><i>Paragraph 8.3.3.1., renumber as paragraph 8.4.3.1. and amend to read:</i></p> <p>"...impactor shall be suspended from a drop rig as shown in Figure <del>25</del><b>30</b>."</p> |
| <p>8.3.3.2. The headform impactor shall be dropped from the specified height by means that ensure instant release onto a rigidly supported flat horizontal steel plate, over 50 mm thick and over 300 x 300 mm square which has a clean dry surface and a surface finish of between 0.2 and 2.0 micrometers.</p>   |  |
| <p>8.3.3.3. The headform impactor shall be dropped with the rear face of the impactor at the test angle specified in paragraph 7.3.5. for the child headform impactor and in paragraph 7.4.5. for the adult headform impactor with respect to the vertical as shown in Figure 25. The suspension of the headform impactor shall be such that it does not rotate during the fall.</p> | <p><i>Paragraph 8.3.3.3., amend to read:</i></p> <p>"... impactor with respect to the vertical as shown in Figure <del>25</del><b>39</b>. The suspension of ..."</p>                   |
| <p>8.3.3.4. The drop test shall be performed three times, with the headform impactor rotated 120° around its symmetrical axis after each test.</p>   | <p><i>Delete (former) Figures 18 to Figure 22, to read:</i></p> <p>"</p>   |

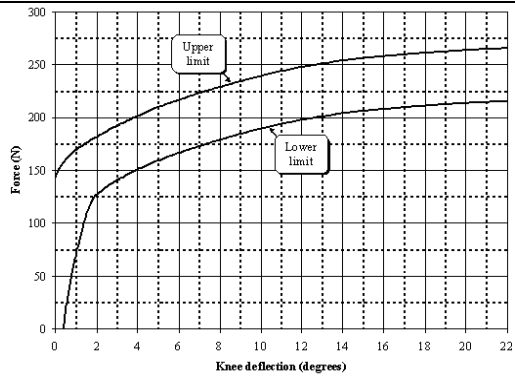


Figure 18: Force versus angle requirement in static lower legform impactor bending certification test (see paragraph 8.1.1.2.)

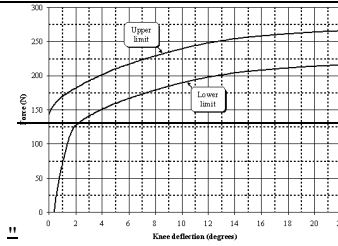
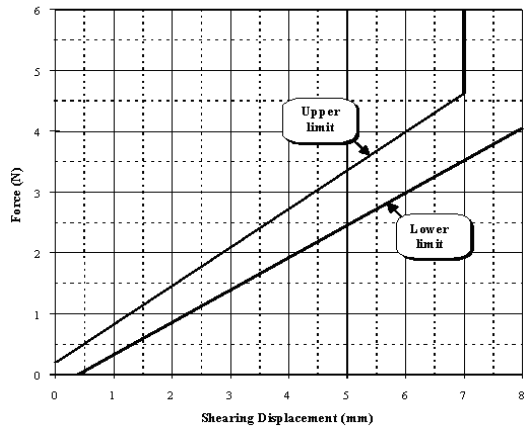


Figure 18: Force versus angle requirement in static lower legform impactor bending certification test (see paragraph 8.1.1.2.)

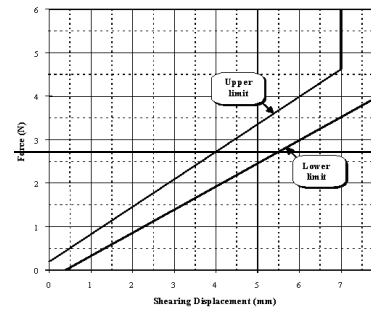


Figure 19: Force versus displacement requirement in static lower legform impactor shearing certification test (see paragraph 8.1.1.3.)



Figure 19: Force versus displacement requirement in static lower legform impactor shearing certification test (see paragraph 8.1.1.3.)

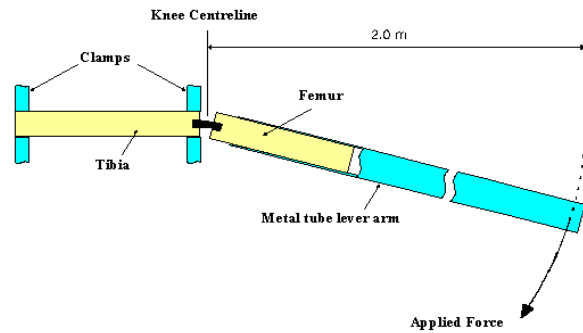


Figure 20: Top View of Test set-up for static lower legform impactor bending certification test (see paragraph 8.1.1.4.)

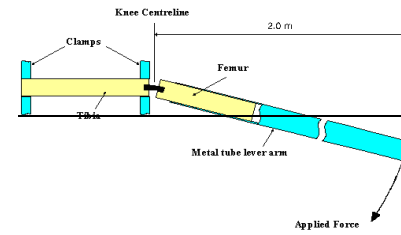


Figure 20: Top View of Test set-up for static lower legform impactor bending certification test (see paragraph 8.1.1.4.)

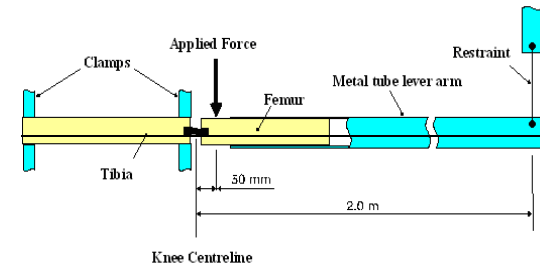


Figure 21: Top View of Test set-up for static lower legform impactor shearing certification test (see paragraph 8.1.1.5.)

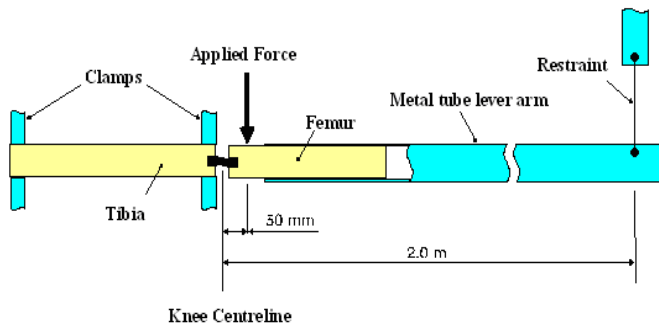


Figure 21: Top View of Test set-up for static lower legform impactor shearing certification test (see paragraph 8.1.1.5.)

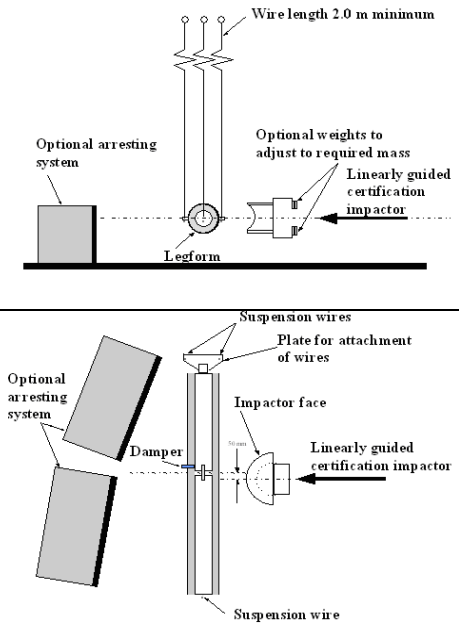
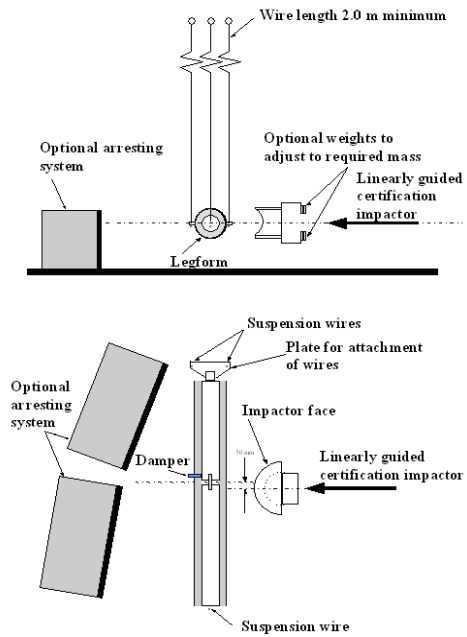


Figure 22: Test set-up for dynamic lower legform impactor certification test (side view top diagram, view from above bottom diagram) (see paragraph 8.1.2.4.1.)

Figure 22: Test set-up for dynamic lower legform impactor certification test (side view top diagram, view from above bottom diagram) (see paragraph 8.1.2.4.1.) -"

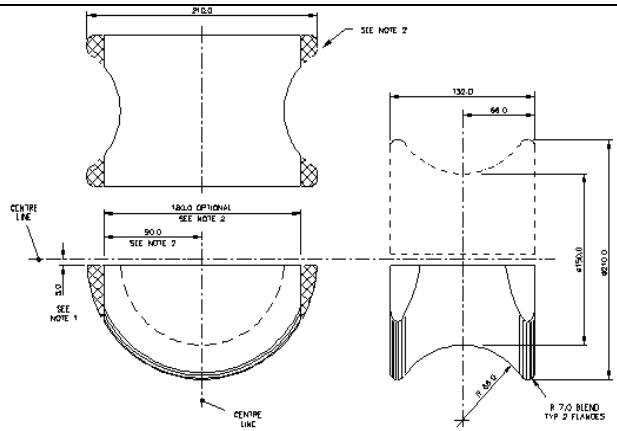


Figure 23: Details of dynamic lower legform certification impactor face (see paragraph 8.1.2.4.2.)

Notes:

1. Saddle may be made as a complete diameter and cut as shown to make two components.
2. The shaded areas may be removed to give the alternative form shown.
3. Tolerance on all dimensions is  $\pm 1.0$  mm.  
Material: Aluminium alloy.

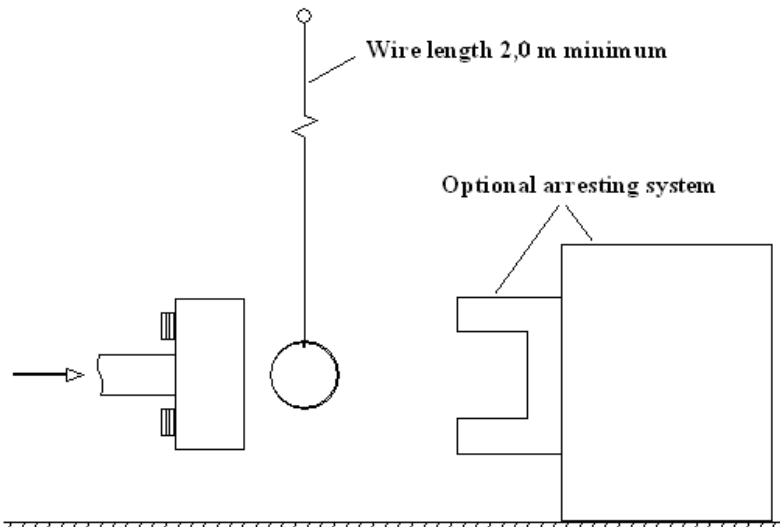


Figure 24. Test set-up for dynamic upper legform impactor certification test  
(see paragraph 8.2.4.6)

|  |  |
|--|--|
|  |  |
|--|--|

...

|  |   |
|--|---|
|  | <p><i>Figures 23 to Figure 25 (former), renumber as<br/>Figures 29 to Figures 31.</i></p> |
|  |   |

...

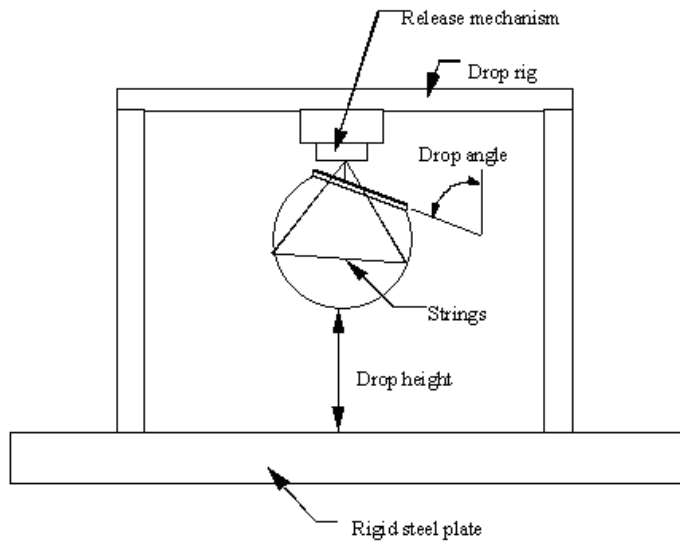


Figure 25. Test set-up for dynamic headform impactor biofidelity test  
(see paragraph 8.3.3.1.)

-----

...

## Justification

[Based on the results of the TEG as well as IG GTR9 PH2 activities, the IG GTR9 PH2 proposes the above-mentioned draft amendments to the gtr on pedestrian protection (GTR No. 9) .

### *Paragraph 3.23.:*

*Paragraph 3.24.:* [To cover tolerances in built-up, adjustment and alignment of a test vehicle in actual testing it recommended to include the concept of the primary reference marks, which is already defined in Part A of gtr9 also into in Part B of gtr9. The definitions shall give clear guidelines and definitions needed to be able to perform the approval test during the type approval of vehicles and verification testing for self-certification. The proposed definitions for test vehicles are already incorporated in applicable regulative language for pedestrian protection.]

*The text of the gtr no. 9 relevant for this proposal is given below:*

*Part A, Chapt. 5., (e) Vehicle design position*

*Page 2*

*"61. As vehicles come in many variants and modifications, the ride height may vary greatly. Taking into account the differences between type approval and self certification, it is recommended that Contracting Parties take this into account upon national implementation of the gtr. As guidance to Contracting Parties, the EU addresses this issue by defining the concept of "primary reference marks". This definition (paragraph 2.2 of EU Commission Decision of 23 December 2003) reads:*

*"Primary reference marks" means holes, surfaces, marks and identification signs on the vehicle body. The type of reference mark used and the vertical (Z) position of each mark relative to the ground shall be specified by the vehicle manufacturer according to the running conditions specified in paragraph 2.3. These marks shall be selected such as to be able to easily check the vehicle front and rear ride heights and vehicle attitude.*

*62. If the primary reference marks are found to be within  $\pm 25$  mm of the design position in the vertical (Z) axis, then the design position shall be considered to be the normal ride height. If this condition is met, either the vehicle shall be adjusted to the design position, or all further measurements shall be adjusted, and tests performed, to simulate the vehicle being at the design position."*

*Insert a new Paragraph 3.30.: new definitions were inserted to introduce the flexible lower legform impactor (editorial)*

*Paragraph 5.1.1.: replaced by flexible lower legform impactor requirements.*

...



*Paragraph 6.3.1.1. to 6.3.1.1.7.2:* replaced by flexible lower legform impactor requirements.

*Delete Figures 12 :* delete figure for EEVC lower legform impactor.

*Insert new Figures 12 to 16 :* insert figures for flexible lower legform impactor.

*Paragraph 6.3.1.2. to 6.3.2.2.1 and Figure 15 (former):* renumbering (editorial).

*Figure 16 (former):* renumbering (editorial).

*Paragraph 7.1.1. to 7.1.1.4.:* replaced by flexible lower legform impactor requirements.

*Figure 17 (former):* renumbering and replaced by flexible lower legform impactor requirements.

*Paragraph 8.1. to 8.1.3.4.4.:* replaced by flexible lower legform impactor requirements.

*Delete Figures 18 to Figure 21 :* delete figure for EEVC lower legform impactor.

*Insert new Figures 22 to 28 :* insert figures for flexible lower legform impactor.

*Paragraph 8.2.4.6. to 8.3.3.3:* renumbering (editorial).

*Figure 23 to Figure 25 (former):* renumbering (editorial).