



## Economic and Social Council

Distr.: General



Original: English

**AVLI 01-03 Rev. 2a**  
**Resulting from the decisions taken**  
**during the second session of AVLI**  
**Brussels, 5 November 2013**

---

### Economic Commission for Europe

Inland Transport Committee

World Forum for Harmonization of Vehicle Regulations

Working Party on Lighting and Light Signalling (GRE)

**Sixty-Ninth session**

Geneva, 8-11 April 2013

**Item 14 of the provisional agenda**

**Regulation No. 86 (Installation of lighting and light-signalling devices for agricultural tractors)**

### **Proposal for Supplement 6 to the 00 series of amendments to Regulation No. 86 (Installation of lighting and light-signalling devices for agricultural tractors)**

**Submitted by the GRE Informal Group "Agricultural Vehicles Lighting Installation" (AVLI)**

The text reproduced below was prepared by the GRE Informal Group "Agricultural Vehicles Lighting Installation" (AVLI) updating Regulation No. 86. It is based on the document E/ECE/324/Rev.1/Add.85/Rev.1. The modifications to the current text of the UN Regulation are marked in bold for new or strikethrough for deleted characters.

The amendments taken during the second session are indicated in red color.

# I. Proposal

Regulation No. 86, amend to read:

## "Uniform provisions concerning the approval of agricultural or forestry vehicles ~~tractors~~ with regard to the installation of lighting and light-signalling devices

### Contents

Regulation	Page
1. Scope .....	4
2. Definitions.....	4
3. Application for approval .....	8
4. Approval .....	9
5. General specifications .....	10
6. Individual specifications .....	14
7. Modification and extension of approval of the vehicle type or of the installation of its lighting and light-signalling devices.....	32
8. Conformity of production.....	32
9. Penalties for non-conformity of production .....	32
10. Production definitely discontinued.....	33
11. Names and addresses of technical services responsible for conducting approval tests, and of administrative departments .....	33
 Annexes	
1. Communication concerning the approval or extension or refusal or withdrawal of approval or production definitely discontinued of a type of agricultural or forestry <b>vehicle tractor</b> with regard to the installation of lighting and light-signalling devices pursuant to Regulation No. 86 ...	34
2. Examples of arrangements of approval marks .....	36
3. Definitions of the terms of paragraphs 2.6. to 2.10 of this Regulation.....	37
4. Visibility of lamps.....	38
5. Direction-indicator lamps – Geometric visibility.....	39
<b>6. Signalling Panels.....</b>	<b>56</b>
<b>7. Lighting and signalling devices on mounted machines and for external projections of vehicles... ..</b>	<b>58</b>

## Regulation No. 86

### Uniform provisions concerning the approval of agricultural or forestry vehicles ~~tractors~~ with regard to the installation of lighting and light-signalling devices

#### 1. Scope

This Regulation applies to vehicles of category T<sup>1</sup>, with regard to the installation of lighting and light-signalling devices.

#### 2. Definitions

For the purposes of this Regulation,

2.1. "Vehicle ~~Tractor~~ type with regard to the installation of lighting and light-signalling devices" means **vehicles** ~~tractors~~ which do not differ in such essential respects as:

2.1.1. The dimensions and exterior shape of the **vehicle** ~~tractor~~;

2.1.2. The number and positioning of the devices;

2.1.3. The following are likewise considered not to be **vehicles** ~~tractors~~ of a different type:

**Vehicles** ~~Tractors~~ which differ within the meaning of paragraphs 2.1.1. and 2.1.2. above, but not in such a way as to entail a change in the type, number, positioning and geometric visibility of the lamps prescribed for the vehicle ~~tractor~~ type in question;

**Vehicles** ~~Tractors~~ on which optional lamps are fitted or are absent;

2.2. "Transverse plane" means a vertical plane perpendicular to the median longitudinal plane of the **vehicle** ~~tractor~~;

2.3. "**Unladen vehicle** ~~tractor~~" means the **vehicle** ~~tractor~~ in running order, i.e. excluding optional accessories but including coolant, oils, fuel, tools and driver;

2.4. "Laden vehicle ~~tractor~~" means the **vehicle** ~~tractor~~ loaded to its technically permissible maximum mass, as stated by the manufacturer, who shall also fix the distribution of this weight between the axles;

2.5. "Lamp" means a device designed to illuminate the road (headlamp) or to emit a light signal. Rear registration-plate lamps and retro-reflectors shall likewise be regarded as lamps;

2.5.1. "Equivalent lamps" means lamps having the same function and **approved under Regulation No. 37 or in conformity with the same requirements**

<sup>1</sup> As defined in the Consolidated Resolution on the Construction of Vehicles (R.E.3.), document ECE/TRANS/WP.29/78/Rev.2, para. 2. - [www.unece.org/trans/main/wp29/wp29wgs/wp29gen/wp29resolutions.html](http://www.unece.org/trans/main/wp29/wp29wgs/wp29gen/wp29resolutions.html)

- authorized in the country in which the vehicle is registered**; such lamps may have different characteristics from those of the lamps with which the vehicle is equipped at the time of approval on condition that they satisfy the requirements of this Regulation;
- 2.5.2. "Independent lamps" means devices having separate lenses, separate light sources, and separate lamp bodies;
- 2.5.3. "Grouped lamps" means devices having separate lenses and separate light sources, but a common lamp body;
- 2.5.4. "Combined lamps" means devices having separate lenses but a common light source and a common lamp body;
- 2.5.5. "Reciprocally incorporated lamps" means devices having separate light sources (or a single light source operating under different conditions), totally or partially common lenses and a common lamp body;
- 2.5.6. "Concealable illuminating lamp" means a headlamp capable of being partly or completely hidden when not in use. This result may be achieved by means of a movable cover, by displacement of the headlamp or by any other suitable means. The term "retractable" is used more particularly to describe a concealable lamp the displacement of which enables it to be inserted within the bodywork;
- 2.5.7. **"Variable-position lamps"** ~~Lamps of variable position~~ " means lamps installed on the **vehicle** ~~tractor~~ which can move in relation to the **vehicle** ~~tractor~~, without being detached;
- 2.5.8. **"Main-beam headlamp"** ~~Driving lamp~~ means the lamp used to illuminate the road over a long distance ahead of the **tractor vehicle**;
- 2.5.9. **"Dipped-beam headlamp"** ~~Passing lamp~~ means the lamp used to illuminate the road ahead of the **tractor vehicle** without causing undue dazzle or discomfort to oncoming drivers and other road-users;
- 2.5.10. "Front fog-lamp" means the lamp used to improve the illumination of the road in case of fog, snowfall, rainstorms or dust clouds;
- 2.5.11. "Reversing lamp" means the lamp used to illuminate the road to the rear of the **vehicle** ~~tractor~~ and to warn other road-users that the **vehicle** ~~tractor~~ is reversing or about to reverse;
- 2.5.12. "Direction-indicator lamp" means the lamp used to indicate to other road-users that the driver intends to change direction to the right or to the left;
- 2.5.13. "Hazard-warning signal" means the device permitting the simultaneous operation of all of a **vehicle's** ~~tractor's~~ direction indicator lamps to draw attention to the fact that the **vehicle** ~~tractor~~ temporarily constitutes a special danger to other road-users;
- 2.5.14. "Stop lamp" means the lamp used to indicate to other road-users to the rear of the **vehicle** ~~tractor~~ that the **longitudinal movement of the vehicle is intentionally retarded** ~~latter's driver is applying the service brake~~;
- 2.5.15. "Rear-registration-plate lamp" means the device used to illuminate the space intended to accommodate the rear registration plate; it may consist of several optical components;
- 2.5.16. "Front position ~~(side)~~ lamp" means the lamp used to indicate the presence and the width of the **vehicle** ~~tractor~~ when the latter is viewed from the front;

- 2.5.17. "Rear position (~~side~~) lamp" means the lamp used to indicate the presence and the width of the ~~vehicle tractor~~ when the latter is viewed from the rear;
- 2.5.18. "Rear fog-lamp" means the lamp used to make the ~~vehicle tractor~~ more easily visible from the rear in dense fog;
- 2.5.19. "Parking lamp" means the lamp used to draw attention to the presence of a stationary ~~vehicle tractor~~ in a built-up area. In such circumstances it replaces the front and rear position (~~side~~) lamps;
- 2.5.20. "End-outline marker lamp" means the lamp fitted to the extreme outer edge as close as possible to the top of the ~~vehicle tractor~~ and intended clearly to indicate the ~~vehicle's tractor's~~ overall width. This signal is intended, for certain ~~vehicles tractors~~, to complement the ~~vehicle's tractor's~~ front and rear position (~~side~~) lamps by drawing particular attention to its bulk;
- 2.5.21. "Work lamp" means a device for illuminating a working area or process;
- 2.5.22. "Retro-reflector" means a device used to indicate the presence of a ~~vehicle tractor~~ by reflection of light emanating from a light source unconnected with the vehicle, the observer being situated near that source. For the purpose of this Regulation, the following are not considered as retro-reflectors:
- 2.5.22.1. Retro-reflecting number plates;
- 2.5.22.2. Other plates and retro-reflecting signals which must be used to comply with a Contracting Party's specifications for use as regards certain categories of vehicles or certain methods of operation.
- 2.5.23. "Side marker lamp" means a lamp used to indicate the presence of the vehicle when viewed from the side;
- 2.5.24. "Daytime running lamp" means a lamp facing in a forward direction used to make the vehicle more easily visible when driving during daytime;
- 2.5.25. "Cornering lamp" means a lamp used to provide supplementary illumination of that part of the road which is located near the forward corner of the vehicle at the side towards which the vehicle is going to turn;
- ~~2.5.26. "Lane keeping lamp" means a lamp that shows the driver the right and left rearmost end of the vehicle during darkness;~~
- 2.5.26. "Exterior Courtesy lamp" means a lamp used to provide supplementary illumination to assist the entry and exit of the vehicle driver and passenger or in loading operations.
- ~~2.5.27. "Manoeuvring lamp" means a lamp used to provide supplementary illumination to the side of the vehicle to assist during slow manoeuvres.~~
- 2.6. "Illuminating surface" (see Annex 3).
- 2.6.1. "Illuminating surface of a lighting device" (paragraphs 2.5.8., 2.5.9., 2.5.10., 2.5.11. and 2.5.25.) means the orthogonal projection of the full aperture of the reflector, or in the case of headlamps with an ellipsoidal reflector of the "projection lens", on a transverse plane. If the lighting device has no reflector, the definition of paragraph 2.6.2. shall be applied. If the light emitting surface of the lamp extends over part only of the full aperture of the reflector, then the projection of that part only is taken into account.

In the case of a dipped-beam headlamp, the illuminating surface is limited by the apparent trace of the cut-off on to the lens. If the reflector and lens are adjustable relative to one another, the mean adjustment should be used.

In the case of AFS being installed: where a lighting function is produced by two or more simultaneously operated lighting units on a given side of the vehicle, the individual illuminating surfaces, taken together, constitute the illuminating surface to be considered (for example, in the figure of paragraph 6.22.4. of Regulation No. 48, the individual illuminating surfaces of the lighting units 8, 9 and 11, regarded together and taking into account their respective location, constitute the illuminating surface to be considered for the right hand side of the vehicle).

- 2.6.2. "Illuminating surface of a light-signalling device other than a retro-reflector" (paragraphs 2.5.11., 2.5.13., 2.5.17., 2.5.18., 2.5.19 and 2.5.24.) means the orthogonal projection of the lamp in a plane perpendicular to its axis of reference and in contact with the exterior light-emitting surface of the lamp, this projection being bounded by the edges of screens situated in this plane, each allowing only 98 per cent of the total luminous intensity of the light to persist in the direction of the axis of reference.

To determine the lower, upper and lateral limits of the illuminating surface only screens with horizontal or vertical edges shall be used to verify the distance to the extreme edges of the vehicle and the height above the ground.

For other applications of the illuminating surface, e.g. distance between two lamps or functions, the shape of the periphery of this illuminating surface shall be used. The screens shall remain parallel, but other orientations are allowed to be used.

In the case of a light-signalling device whose illuminating surface encloses either totally or partially the illuminating surface of another function or encloses a non-lighted surface, the illuminating surface may be considered to be the light emitting surface itself (see e.g. Annex 3, Parts 2, 3, 5 and 6).

- 2.6.3. "Illuminating surface of a retro-reflector" (paragraph 2.5.22.) means, as declared by the applicant during the component approval procedure for the retro-reflectors, the orthogonal projection of a retro-reflector in a plane perpendicular to its axis of reference and delimited by planes contiguous to the declared outermost parts of the retro-reflectors' optical system and parallel to that axis. For the purposes of determining the lower, upper and lateral edges of the device, only horizontal and vertical planes shall be considered.

- 2.7. The "apparent surface" for a defined direction of observation means, at the request of the manufacturer or his duly accredited representative, the orthogonal projection of:

Either the boundary of the illuminating surface projected on the exterior surface of the lens;

Or the light-emitting surface;

**Only in the case of a light-signalling device producing variable luminous intensities, its apparent surface that may be variable as specified in paragraph 2.7.1.3. shall be considered under all conditions permitted by the variable intensity control, if applicable.**

**In a plane perpendicular to the direction of observation and tangential to the most exterior point of the lens. Different examples of the application of apparent surface can be found in Annex 3 to this Regulation.**

- 2.8. "Axis of reference" means the characteristic axis of the light signal determined by the manufacturer of the lamp for use as the direction of reference ( $H = 0^\circ$ ,  $V = 0^\circ$ ) for photometric measurements and when fitting the lamp on the **vehicle tractor**;
- 2.9. "Centre of reference" means the intersection of the axis of reference with the exterior light-emitting surface, specified by the manufacturer of the lamp;
- 2.10. "Angles of geometric visibility" means the angles which determine the field of the minimum solid angle in which the apparent surface of the lamp is visible. That field of the solid angle is determined by the segments of the sphere of which the centre coincides with the centre of reference of the lamp and the equator is parallel with the ground. These segments are determined in relation to the axis of reference. The horizontal angles  $\beta$  correspond to the longitude and the vertical angles  $\alpha$  to the latitude.**
- 2.11. "Extreme outer edge" on either side of the **vehicle tractor** means the plane parallel with the median longitudinal plane of the **vehicle tractor** and coinciding with its lateral outer edge, disregarding the projection:
- 2.11.1. of tyres near their point of contact with the ground and connections for tyre-pressure gauges **and tyre inflating/deflating devices/ducts**;
- 2.11.2. of any anti-skid devices which may be mounted on the wheels;
- 2.11.3. of **devices for indirect vision**;
- 2.11.4. of side direction indicator lamps, end-outline marker lamps, front and rear position (~~side~~) lamps, parking lamps and **side retro-reflectors**;
- 2.11.5. of customs seals affixed to the **vehicle tractor** and devices for securing and protecting such seals;
- 2.12. "Overall width" means the distance between the two vertical planes defined in paragraph 2.11. above;
- ~~2.13. "A single lamp" includes any combination of two or more lamps, whether identical or not, having the same function and color, if it comprises devices, the projection of whose aggregate light emitting surfaces in a given transverse plane occupies 60 per cent or more of the area of the smallest rectangle circumscribing the projections of the light emitting surfaces of the aforementioned lamps, provided that such combination is, where approval is required, approved as a single lamp.~~
- ~~————— This possible combination does not apply to main beam headlamps driving lamps, dipped beam headlamps passing lamps, front fog lamps or side retro-reflectors;~~
- 2.13. "Single and multiple lamp"**
- 2.13.1. "A single lamp" means:**

(a) A device or part of a device having one lighting or light-signalling function, one or more light source(s) and one apparent surface in the direction of the reference axis, which may be a continuous surface or composed of two or more distinct parts; or

(b) Any assembly of two independent lamps, whether identical or not, having the same function, both approved as type "D" lamp and installed so that:

(i) The projection of their apparent surfaces in the direction of the reference axis occupies not less than 60 per cent of the smallest quadrilateral circumscribing the projections of the said apparent surfaces in the direction of the reference axis; or

(ii) The distance between two adjacent/tangential distinct parts does not exceed 15 mm when measured perpendicularly to the reference axis; or

(c) Any assembly of two independent retro-reflectors, whether identical or not, that have been approved separately and are installed in such a way that:

(i) The projection of their apparent surfaces in the direction of the reference axis occupies not less 60 per cent of the smallest quadrilateral circumscribing the projections of the said apparent surfaces in the direction of the reference axis; or

(ii) The distance between two adjacent/tangential distinct parts does not exceed 15 mm when measured perpendicularly to the reference axis.

**2.13.2.** "Two lamps" or "an even number of lamps" means a single light-emitting surface in the shape of a band or strip if such band or strip is placed symmetrically in relation to the median longitudinal plane of the vehicle, extends on both sides to within at least 0.4 m of the extreme outer edge of the vehicle, and is not less than 0.8 in length; the illumination of such surface shall be provided by not less than two light sources placed as **close** as possible to its ends; the light-emitting surface may be constituted by a number of juxtaposed elements on condition that the projections of the several individual light-emitting surfaces on a transverse plane occupy not less than 60 per cent of the area of the smallest rectangle circumscribing the projections of the said individual light-emitting surfaces;

~~2.14. "Two lamps" or "an even number of lamps" includes a single illuminating surface in the shape of a band, if placed symmetrically in relation to the median longitudinal plane of the tractor and extending on both sides to within not less than 400 mm of the extreme outer edge of the tractor, and being not less than 800 mm long. The illumination of such a surface shall be provided by not less than two light sources placed as close as possible to its ends. The illuminating surface may be constituted by a number of juxtaposed elements on condition that the projections of the several individual illuminating surfaces in the same transverse plane occupy not less than 60 per cent of the area of the smallest rectangle circumscribing the projections of those individual illuminating surfaces;~~

**2.14.** "Distance between two lamps" which face in the same direction, means the distance between the orthogonal projections in a plane perpendicular to the



direction in question of the outlines of the two illuminating surfaces as defined according to the case mentioned in paragraph 2.6.;

- 2.15. "Optional lamp" means a lamp, the **installation** of which is left to the discretion of the manufacturer.
- 2.16. **"Operating tell-tale" means a visual or auditory signal (or any equivalent signal) indicating that a device has been switched on and is operating correctly or not.**
- 2.17. "Circuit-closed tell-tale" means a tell-tale showing that a device has been switched on but not showing whether it is operating correctly or not.
- 2.18. **"Colour of the light emitted from the device" The definitions of the colour of the light emitted given in Regulation No. 48 and its series of amendments in force at the time of application for type approval shall apply to this Regulation.**
- 2.19. **"Signalling devices other than lamps"**
- 2.19.1. "Signalling panel" means a device used to indicate to other road users the presence of a wide or long vehicle when viewed from the front, rear or side.
- [2.19.2. "Speed Identification Symbol" means a sign used to indicate when viewed from the rear to other road users the maximum specified ground speed for which a vehicle has been designed.]
- 2.19.3. "SMV rear marking plate", a triangular plate with truncated corners with a characteristic pattern faced with retro-reflective and fluorescent material or devices (class 1); or with retro-reflective materials or devices only (class 2) (see e.g. Regulation No. 69).
- 2.19.4. **"Conspicuity marking" means a device intended to increase the conspicuity of a vehicle, when viewed from the side or rear (or in the case of trailers, additionally from the front), by the reflection of light emanating from a light source not connected to the vehicle, the observer being situated near the source.**
- 2.19.4.1. **"Contour marking" means a conspicuity marking intended to indicate the horizontal and vertical dimensions (length, width and height) of a vehicle.**
- 2.19.4.1.1. **"Full contour marking" means a contour marking that indicates the outline of the vehicle by a continuous line.**
- 2.19.4.1.2. **"Partial contour marking" means a contour marking that indicates the horizontal dimension of the vehicle by a continuous line, and the vertical dimension by marking the upper corners.**
- 2.19.4.2. **"Line marking" means a conspicuity marking intended to indicate the horizontal dimensions (length and width) of a vehicle by a continuous line.**
- ~~2.20. "Bend lighting" means a lighting function to provide enhanced illumination in bends.~~
- 2.20. "Emergency stop signal" means a signal to indicate to other road users to the rear of the vehicle that a high retardation force has been applied to the vehicle relative to the prevailing road conditions.

- 2.35. "H plane" means the horizontal plane containing the centre of reference of the lamp.**

### **3. Application for approval**

- 3.1. The application for approval of a vehicle type with regard to the installation of its lamps shall be submitted by the vehicle manufacturer or his duly accredited representative.
- 3.2. It shall be accompanied by the undermentioned documents in triplicate and the following particulars:
- 3.2.1. A description of the vehicle type with regard to the items mentioned in paragraphs 2.1.1. to 2.1.3. above; the vehicle type duly identified shall be specified;
- 3.2.2. A list of the devices intended by the manufacturer to form the lighting and signalling equipment; the list may include several types of device for each function, in addition, the list may include in respect of each function the additional annotation "or equivalent devices";
- 3.2.3. A diagram of the lighting and signalling installation as a whole, showing the position of the various devices on the vehicle;
- 3.2.4. A drawing or drawings of each lamp showing the illuminating surface, as defined in paragraph 2.6. above.
- 3.3. An unladen vehicle fitted with a complete set of lighting and signalling equipment and representative of the vehicle type to be approved shall be submitted to the technical service conducting approval tests.

### **4. Approval**

- 4.1. If the vehicle type submitted for approval pursuant to this Regulation meets the requirements of the Regulation in respect of all the lights specified in the list, approval of that vehicle type shall be granted.
- 4.2. An approval number shall be assigned to each type approved. Its first two digits (at present 00 for the Regulation in its original form) shall indicate the series of amendments incorporating the most recent major technical amendments to the Regulation. The same Contracting Party may not assign the same number to another vehicle type or to the same vehicle type submitted with equipment not specified in the list referred to in paragraph 3.2.2. above subject to paragraph 7. of this Regulation.
- 4.3. Notice of approval or of extension or refusal or withdrawal of approval or production definitely discontinued of a vehicle type pursuant to this Regulation shall be communicated to the parties to the Agreement which apply this Regulation by means of a form conforming to the model in Annex 1 to this Regulation.
- 4.4. There shall be affixed, conspicuously and in a readily accessible place specified on the approval form, to every vehicle conforming to a vehicle type approved under this Regulation an international approval mark consisting of:

- 4.4.1. A circle surrounding the letter "E", followed by the distinguishing number of the country which has granted approval <sup>2</sup>.
- 4.4.2. The number of this Regulation, followed by the letter "R", a dash and the approval number to the right of the circle prescribed in paragraph 4.4.1.
- 4.5. If the vehicle conforms to a vehicle type approved under one or more other Regulations annexed to the Agreement, in the country which has granted approval under this Regulation, the symbol prescribed in paragraph 4.4.1. need not be repeated; in such a case the Regulation and approval numbers and the additional symbols of all the Regulations under which approval has been granted in the country which has granted approval under this Regulation shall be placed in vertical columns to the right of the symbol prescribed in paragraph 4.4.1.
- 4.6. The approval mark shall be placed close to or on the vehicle data plate affixed by the manufacturer.
- 4.7. The approval mark shall be clearly legible and be indelible.
- 4.8. Annex 2 to this Regulation gives an example of the arrangements of approval marks.

## 5. General specifications

- 5.1. The lighting and light-signalling devices must be so fitted that under normal conditions of use, and notwithstanding any vibration to which they may be subjected, they retain the characteristics laid down in this Regulation and enable the ~~vehicle tractor~~ to comply with the requirements of this Regulation. In particular, it shall not be possible for the adjustment of the lamps to be inadvertently disturbed.
- 5.1.1. Vehicles must be fitted with the permanently connected socket outlet specified in ISO standard 1724 (1980) (Electrical connections for vehicles with 6 or 12 volt electrical systems applying more specifically to private motor cars and lightweight trailers or caravans), or ISO 1185 (1975) (Electrical connections between towing and towed vehicles having 24 volt electrical systems used for international commercial transport purposes) or both when they have a connection for attaching trailed vehicles or mounted machines.**
- ~~5.1.1. Tractors must be equipped with electrical connectors to enable a detachable light signalling system to be used. In particular tractors must be fitted with the permanently connected socket outlet specified in ISO standard 1724 (1980) (Electrical connections for vehicles with 6 or 12 volt electrical systems applying more specifically to private motor cars and lightweight trailers or caravans), ISO 1185 (1975) (Electrical connections between towing and towed vehicles having 24 volt electrical systems used for international commercial transport purposes). In the case of ISO standard~~

<sup>2</sup>

The distinguishing numbers of the Contracting Parties to the 1958 Agreement are reproduced in Annex 3 to the Consolidated Resolution on the Construction of Vehicles (R.E.3), document ECE/TRANS/WP.29/78/Rev.2/Amend.1 - [www.unece.org/trans/main/wp29/wp29wgs/wp29gen/wp29resolutions.html](http://www.unece.org/trans/main/wp29/wp29wgs/wp29gen/wp29resolutions.html)

~~1185 (1975), the function of contact 2 shall be restricted to the rear position (side) lamp and to the end-outline marker lamp on the left hand side.~~

- 5.2. The illuminating lamps described in paragraphs 2.5.8., 2.5.9. and 2.5.10. shall be so installed that correct adjustment of their orientation can easily be carried out.
- 5.3. For all light-signalling devices, the reference axis of the lamp when fitted to the ~~vehicle tractor~~ must be parallel with the bearing plane of the vehicle ~~tractor~~ on the road and with the longitudinal plane of the ~~vehicle tractor~~. In each direction a tolerance of  $\pm 3^\circ$  shall be allowed. In addition, any specific instructions as regards fitting laid down by the manufacturer must be complied with.
- 5.4. In the absence of specific instructions, the height and orientation of the lamps shall be verified with the vehicle unladen and placed on a flat horizontal surface.
- 5.5. In the absence of specific instructions, lamps constituting a pair shall:
  - 5.5.1. Be mounted symmetrically in relation to the median longitudinal plane;
  - 5.5.2. Be symmetrical to one another in relation to the median longitudinal plane;
  - 5.5.3. Satisfy the same colorimetric requirements; and
  - 5.5.4. Have substantially identical photometric characteristics.
- 5.6. On ~~vehicles tractors~~ whose external shape is asymmetrical, the requirements of paragraphs 5.5.1. and 5.5.2. shall be satisfied as far as possible. These requirements shall be regarded as having been met if the distance of the two lamps from the median longitudinal plane and from the bearing plane on the ground is the same.
- 5.7. **Grouped, combined or reciprocally incorporated lamps**
  - 5.7.1. **Lamps may be grouped, combined or reciprocally incorporated with one another provided that all requirements regarding colour, position, orientation, geometric visibility, electrical connections and other requirements, if any, are fulfilled.**
    - 5.7.1.1. **The photometric and colorimetric requirements of a lamp shall be fulfilled when all other functions with which this lamp is grouped, combined or reciprocally incorporated are switched OFF.**  
**However, when a front or rear position lamp is reciprocally incorporated with one or more other function(s) which can be activated together with them, the requirements regarding colour of each of these other functions shall be fulfilled when the reciprocally incorporated function(s) and the front or rear position lamps are switched ON.**
    - 5.7.1.2. **Stop lamps and direction-indicator lamps are not permitted to be reciprocally incorporated.**
    - 5.7.1.3. **Where stop lamps and direction-indicator lamps are grouped, the following conditions shall be met:**
      - 5.7.1.3.1. **Any horizontal or vertical straight line passing through the projections of the apparent surfaces of these functions on a plane perpendicular to the reference axis, shall not intersect more than two borderlines separating adjacent areas of different colour;**

- 5.7.1.3.2. Their apparent surfaces in the direction of the reference axis, based upon the areas bounded by the outline of their light emitting surfaces, do not overlap.
- 5.7.2. Where the apparent surface of a single lamp is composed of two or more distinct parts, it shall satisfy the following requirements:
- 5.7.2.1. Either the total area of the projection of the distinct parts on a plane tangent to the exterior surface of the outer lens and perpendicular to the reference axis shall occupy not less than 60 per cent of the smallest quadrilateral circumscribing the said projection, or the distance between two adjacent/tangential distinct parts shall not exceed 15 mm when measured perpendicularly to the reference axis. This requirement shall not apply to a retro-reflector.
- 5.7.2.2. Or, in the case of interdependent lamps, the distance between adjacent apparent surfaces in the direction of the reference axis does not exceed 75 mm when measured perpendicularly to the reference axis.
- 5.8. The maximum height above the ground shall be measured from the highest point and the minimum height from the lowest point of the apparent surface in the direction of the reference axis.
- Where the (maximum and minimum) height above the ground clearly meets the requirements of the Regulation, the exact edges of any surface need not be determined.
- 5.8.1. For the purposes of reducing the geometric visibility angles, the position of a lamp with regard to height above the ground, shall be measured from the H plane.
- 5.8.2. In the case of dipped-beam headlamp, the minimum height in relation to the ground is measured from the lowest point of the effective outlet of the optical system (e.g. reflector, lens, projection lens) independent of its utilisation.
- 5.8.3. The position, as regards width, will be determined from that edge of the apparent surface in the direction of the reference axis which is the furthest from the median longitudinal plane of the vehicle when referred to the overall width, and from the inner edges of the apparent surface in the direction of the reference axis when referred to the distance between lamps.
- Where the position, as regards width, clearly meets the requirements of the Regulation, the exact edges of any surface need not be determined.
- 5.9. In the absence of specific instructions, the photometric characteristics (e.g. intensity, colour, apparent surface, etc.) of a lamp shall not be intentionally varied during the period of activation of the lamp.
- 5.9.1. Direction-indicator lamps, the vehicle-hazard warning signal, amber side-marker lamps complying with paragraph 6.18.7. below, and the emergency stop signal shall be flashing lamps.
- 5.9.2. The photometric characteristics of any lamp may vary:
- (a) In relation to the ambient light;
  - (b) As a consequence of the activation of other lamps; or

(c) When the lamps is being used to provide another lighting function;

provided that any variation in the photometric characteristics is in compliance with the technical provisions for the lamp concerned.

- 5.10.** No red light which could give rise to confusion shall be emitted from a lamp as defined in paragraph 2.7. in a forward direction and no white light which could give rise to confusion, shall be emitted from a lamp as defined in paragraph 2.7. in a rearward direction. No account shall be taken of lighting devices fitted for the interior lighting of the vehicle. In case of doubt, this requirement shall be verified as follows:
- 5.10.1.** For the visibility of red light towards the front of a vehicle, with the exception of a red rearmost side-marker lamp, there must be no direct visibility of the apparent surface of a red lamp if viewed by an observer moving within Zone 1 as specified in Annex 4;
- 5.10.2.** For the visibility of white light towards the rear, with the exception of reversing lamps and white side conspicuity markings fitted to the vehicle, there must be no direct visibility of the apparent surface of a white lamp if viewed by an observer moving within Zone 2 in a transverse plane situated 25 m behind the vehicle (see Annex 4);
- 5.10.3.** In their respective planes, the zones 1 and 2 explored by the eye of the observer are bounded:
- 5.10.3.1.** In height, by two horizontal planes 1 m and 2.2 m respectively above the ground;
- 5.10.3.2.** In width, by two vertical planes which, forming to the front and to the rear respectively an angle of 15° outwards from the vehicle's median longitudinal plane, pass through the point or points of contact of vertical planes parallel to the vehicle's median longitudinal plane delimiting the vehicle's overall width; if there are several points of contact, the foremost shall correspond to the forward plane and the rearmost to the rearward plane.
- 5.11.** The electrical connections shall be such that the front and rear position lamps, the end-outline marker lamps, if they exist, the side-marker lamps, if they exist, and the rear registration plate lamp can only be switched ON and OFF simultaneously.
- ~~The electrical connections must be such that the front and rear position (side) lamps, the end-outline marker lamps if they exist, and the rear registration plate lamp can only be switched on and off simultaneously. This is not valid when using front and rear position (side) lamps as parking lamps.~~
- This condition does not apply:**
- 5.11.1.** When front and rear position lamps are switched ON, as well as side-marker lamps when combined or reciprocally incorporated with said lamps, as parking lamps;
- 5.11.2.** When side-marker lamps are permitted to flash.
- 5.11.3.** To front position lamps when their function is substituted under the provisions of paragraph 5.12.1. below.

- 5.12.** The electrical connections shall be such that the main-beam and dipped-beam headlamps and the front fog lamps cannot be switched on unless the lamps referred to in paragraph 5.11. are also switched on. This requirement shall not apply, however, to main-beam or dipped-beam headlamps when their luminous warnings consist of the intermittent lighting up at short intervals of the main-beam headlamp or the intermittent lighting up at short intervals of the dipped-beam headlamp or the alternate lighting up at short intervals of the main-beam and dipped-beam headlamps.

~~The electrical connections must be such that the driving lamps and passing lamps, and the front and rear fog lamps cannot be switched on unless the lamps referred to in paragraph 5.11. are also switched on. This requirement shall not apply, however, to driving lamps or passing lamps when their luminous warnings consist of the intermittent lighting up at short intervals of the passing lamps or the intermittent lighting up of the driving lamps or the alternate lighting up at short intervals of the passing lamps and driving lamps.~~

~~The function of the circuit-closed tell tales may be fulfilled by operational tell tales.~~

- 5.12.1.** The dipped-beam headlamps and/or the main-beam headlamps and/or the front fog lamps may substitute the function of the front position lamps, provided that:

- 5.12.1.1.** Their electrical connections are such that in case of failure of any of these lighting devices the front position lamps are automatically re-activated; and

- 5.12.1.2.** The substituting lamp/function meets, for the respective position lamp, the requirements concerning paragraphs 6.8.1. to 6.8.6., and

- 5.12.1.3.** appropriate evidence demonstrating compliance with the requirements indicated in paragraph 5.12.1.2. above is provided in the test reports of the substituting lamp.

- 5.13.** The function of the circuit-closed tell-tales may be fulfilled by operational tell-tales.

- 5.14.** The colors of the light emitted by the lamps<sup>3</sup> are the following:

**Main-beam headlamp: White**

**Dipped-beam headlamp: White**

**Front fog lamp: White or selective yellow**

**Reversing lamp: White**

**Direction-indicator lamp: Amber**

**Hazard warning signal: Amber**

**Stop lamp: Red**

**Emergency stop signal: Amber or red**

<sup>3</sup> Measurement of the chromaticity coordinates of the light emitted by the lamps is not part of this regulation.

**Rear registration plate lamp: White**

**Front position lamp: White**

**Rear position lamp: Red**

**Rear fog lamp: Red**

**Parking lamp: White in front, red at the rear, amber if reciprocally incorporated in the side direction indicator lamps or in the side-marker lamps.**

**Side-marker lamp: Amber; however the rearmost side-marker lamp can be red if it is grouped or combined or reciprocally incorporated with the rear position lamp, the rear end-outline marker lamp, the rear fog lamp, the stop lamp or is grouped or has part of the light emitting surface in common with the rear retro-reflector.**

**End-outline marker lamp: White in front, red at the rear**

**Daytime running lamp: White**

**Rear retro-reflector, non-triangular: Red**

**Rear retro-reflector, triangular: Red**

**Front retro-reflector, non-triangular: white or colourless**

**Side retro-reflector, non- triangular: Amber; however the rearmost side retro-reflector can be red if it is grouped or has part of the light emitting surface in common with the rear position lamp, the rear end outline marker lamp, the rear fog lamp, the stop-lamp, the red rearmost side-marker lamp or the rear retro-reflector, non- triangular.**

**Cornering lamp: White**

**Conspicuity marking: White or yellow to the side; Red or yellow to the rear<sup>4</sup>.**

**Lane keeping light: White**

**Exterior courtesy lamp: White.**

**Signalling panels: White/Red stripes**

## **5.15. Concealable lamps**

**5.15.1.** The concealment of lamps shall be prohibited, with the exception of **main-beam headlamps** ~~driving lamps~~, **dipped-beam headlamps** ~~passing lamps~~, and front fog-lamps.

**5.15.2.** An illuminating device in the position of use shall remain in that position if the malfunction referred to in paragraph 5.15.2.1. occurs alone or in conjunction with one of the malfunctions described in paragraph 5.15.2.2.:

**5.15.2.1.** The absence of power for manipulating the lamp;

**5.15.2.2.** A break, impedance, or short-circuit to earth in the electrical circuit, defects in the hydraulic or pneumatic leads, Bowden cables, solenoids or

---

<sup>4</sup> Nothing in this Regulation shall preclude the Contracting Parties applying this Regulation from allowing the use of white conspicuity markings to the rear in their territories.



**other components controlling or transmitting the energy intended to activate the concealment device.**

- ~~5.13.2.2. Accidental opening of the supply circuit, earth leakage, defect in solenoids, defects in the hydraulic or compressed air lines, Bowden cables, flexible leads or other components controlling or transmitting the energy intended to actuate the concealment device.~~
- 5.15.3.** In the event of a defect in the concealment control a concealed lighting device shall be capable of being moved into the positions of use without the aid of tools.
- 5.15.4.** Illuminating devices which are manipulated by power shall be brought into the position of use and switched on by means of a single control, without excluding the possibility of moving them into the position of use without switching them on. However, in the case of grouped- **main-beam headlamps driving lamps** and **dipped-beam headlamps passing lamps**, the control referred to above is required only to activate the **dipped-beam headlamps passing lamps**.
- 5.15.5.** It must not be possible deliberately, from the driver's seat, to stop the movement of switched-on headlamps before they reach the position of use. If there is a danger of dazzling other road users by the movement of headlamps, they may light up only when they have reached their final position.
- 5.15.6.** At temperatures of -30 °C to +50 °C an illuminating device which is manipulated by power must be capable of reaching the position of use within three seconds of initial operation of the control.
- 5.16. Variable position lamps ~~Lamps of variable position~~**
- 5.16.1. The position of all lamps may be varied except main-beam headlamps, dipped-beam headlamps and at least one pair of rear reflectors ~~The position of the direction indicator lamps, the front and rear position (side) lamps and the stop lamps may be varied, provided that:~~**
- 5.16.1.1.** These lamps remain attached to the ~~vehicle tractor~~ when their position is altered;
- 5.16.1.2.** These lamps shall be capable of being locked in the position required by traffic conditions. Locking **shall** be automatic.
- 5.17. General provisions relating to geometric visibility**
- 5.17.1. There shall be no obstacle on the inside of the angles of geometric visibility to the propagation of light from any part of the apparent surface of the lamp observed from infinity. However, no account is taken of obstacles, if they were already presented when the lamp was type-approved.**
- 5.17.2. If measurements are taken closer to the lamp, the direction of observation shall be shifted parallel to achieve the same accuracy.**
- 5.17.3. If, when the lamp is installed, any part of the apparent surface of the lamp is hidden by any further parts of the vehicle, proof shall be furnished that the part of the lamp not hidden by obstacles still conforms to the photometric values prescribed for the approval of the device.**

5.15. ~~The colors of the light emitted by the lamps<sup>5</sup> referred to in this Regulation shall be as follows:~~

- ~~Driving lamp: white or selective yellow~~
- ~~Passing lamp: white or selective yellow~~
- ~~Front fog lamp: white or selective yellow (1968 Convention on Road Traffic, Annex 5, appendix, footnote 3)~~
- ~~Reversing lamp: white~~
- ~~Direction indicator lamp: amber~~
- ~~Hazard warning signal: amber~~
- ~~Stop lamp: red~~
- ~~Rear registration plate lamp: white~~
- ~~Front position (side) lamp: white (selective yellow shall be permitted if this lamp is reciprocally incorporated in a selective yellow headlamp)~~
- ~~Rear position (side) lamp: red~~
- ~~Rear fog lamp: red~~
- ~~Parking lamp: white in front, red at the rear, amber if reciprocally incorporated in the direction indicator lamps~~
- ~~End outline marker lamp: white in front, red at the rear~~
- ~~Work lamp: no specification~~
- ~~Rear retro reflectors: red~~
- ~~Non triangular side retro reflectors: amber.~~

~~The definition of the colours of the lamps shall conform to that given in Annex 5 to the Convention on Road Traffic (1968).~~

**~~5.17. Lighting and signalling devices for external projections of vehicles~~**

**~~The installation of lighting and signalling devices for external projections of vehicles shall comply with Annex 7.~~**

~~5.16. Every tractor submitted for approval pursuant to this Regulation shall be equipped with the following lighting and light signalling devices:~~

- ~~5.16.1. Passing lamps (paragraph 6.2.);~~
- ~~5.16.2. Direction indicator lamps (paragraph 6.5.);~~
- ~~5.16.3. Hazard warning signal (paragraph 6.6.);~~
- ~~5.16.4. Front position (side) lamps (paragraph 6.8.);~~
- ~~5.16.5. Rear position (side) lamps (paragraph 6.9.);~~

<sup>5</sup> ~~Measurement of the chromaticity coordinates of the light emitted by the lamps is not part of this Regulation.~~

- 5.16.6. ~~Rear retro reflectors (paragraph 6.14.);~~
- 5.16.7. ~~Stop lamps (paragraph 6.7.);~~
- 5.16.8. ~~End outline marker lamps (paragraph 6.12.) for tractors exceeding 2.1 m in width. Forbidden on all other tractors.~~
- 5.17. ~~It may, in addition, be equipped with the following light signalling devices:~~
- 5.17.1. ~~Driving lamps (paragraph 6.1.);~~
- 5.17.2. ~~Front fog lamps (paragraph 6.3.);~~
- 5.17.3. ~~Reversing lamp(s) (paragraph 6.4.);~~
- 5.17.4. ~~Rear fog lamp(s) (paragraph 6.10.);~~
- 5.17.5. ~~Parking lamps (paragraph 6.11.);~~
- 5.17.6. ~~Work lamp(s) (paragraph 6.13.);~~
- 5.17.7. ~~Non triangular side retro reflectors (paragraph 6.15.);~~
- 5.18. ~~The fitting of each of the lighting and light signalling devices mentioned in paragraphs 5.16. and 5.17. above shall be effected in conformity with the relevant requirements in paragraph 6. of this Regulation.~~
- 5.19. ~~The fitting of any lighting and light signalling devices other than those mentioned in paragraphs 5.16. and 5.17. above is prohibited for the purposes of type approval. This provision does not prevent a contracting party to require or prohibit:~~
- 5.19.1. ~~An approved type special warning lamp, or~~
- 5.19.2. ~~An appropriate illuminating device for the rear registration plate if it exists and its lighting is required.~~

## 6. Individual specifications

- 6.1. **Main-beam headlamps** ~~Driving lamps~~
- 6.1.1. **Presence:** **Optional.**
- 6.1.2. Number: Two or four.
- 6.1.3. Arrangement: No individual specifications.
- 6.1.4. Position in:
- 6.1.4.1. Width: The outer edges of the illuminating surface shall in no case be closer to the extreme outer edge of the ~~vehicles tractors~~ than the outer edges of the illuminating surface of the **dipped-beam headlamps** ~~passing lamps~~.
- 6.1.4.2. Height: No individual specifications.
- 6.1.4.3. Length: **At the front of the vehicle. This requirement shall be deemed to be satisfied if the light emitted does not cause discomfort to the driver either directly or indirectly through the devices for indirect**

**vision and/or other reflecting surfaces of the vehicle.**

- 6.1.5. Geometric visibility: The visibility of the illuminating surface, including its visibility in areas which do not appear to be illuminated in the direction of observation considered, shall be ensured within a divergent space defined by generating lines based on the perimeter of the illuminating surface and forming an angle of not less than 5° with the axis of reference of the headlamp.
- 6.1.6. **Orientation:** ~~Towards the front. Forwards.~~  
 Apart from the devices necessary to maintain correct adjustment and when there are two pairs of **main-beam headlamps driving-lamps**, one pair, consisting of headlamps functioning as **main-beam headlamp driving-lamp** only, may swivel, according to the angle of lock on the steering, about an approximately vertical axis.
- ~~6.1.7. May be "grouped": With the **dipped-beam headlamp** passing lamp and the other front lamps.~~
- ~~6.1.8. May not be "combined": With any other lamp.~~
- ~~6.1.9. May be "reciprocally incorporated":~~
- ~~6.1.9.1. With the **dipped-beam headlamp** passing lamp, unless the **main-beam headlamp** driving lamp swivels according to the angle of lock of the steering;~~
- ~~6.1.9.2. with the front position (side) lamp;~~
- ~~6.1.9.3. with the front fog lamp;~~
- ~~6.1.9.4. with the parking lamp.~~
- 6.1.7. Electrical connections: The **main-beam headlamp driving lamp** may be switched on either simultaneously or in pairs. For changing over from the **dipped** ~~passing~~ to the **main- driving** beam at least one pair of **main beams driving lamps** must be switched on. For changing over from the **main driving** to the **dipped- passing** beam all **main-beam headlamps driving lamps** must be switched off simultaneously.  
 The **dipped beams** ~~passing lamps~~ may remain switched on at the same time as the **main beams driving lamps**.
- 6.1.8. "Circuit closed" tell-tale: Mandatory. **Color: blue**
- 6.1.9. Other requirements:

- 6.1.9.1. The aggregate maximum intensity of the main beams which can be switched on simultaneously shall not exceed ~~225,000 cd~~ **430,000 cd, which corresponds to a reference value of 100.**
- 6.1.9.2. This maximum intensity shall be obtained by adding together the individual ~~maximum intensities measured at the time of component type approval and shown on the relevant approval reports.~~ **reference marks which are indicated on the several headlamps. The reference mark "10" shall be given to each of the headlamps marked "R" or "CR".**
- 6.2. **Dipped-beam headlamps** ~~Passing lamps~~
- 6.2.1. **Presence: Mandatory.**
- 6.2.2. Number: Two (or four - see paragraph 6.2.4.2.1.).
- 6.2.3. Arrangement: No individual specifications.
- 6.2.4. Position in:
- 6.2.4.1. Width: No individual specifications.
- 6.2.4.2. Height: ~~If only two dipped-beam headlamps are fitted minimum 500 mm and maximum 1,500 mm above the ground.~~
- 
- ~~If only two passing lamps are fitted: minimum 500 mm and maximum 1,200 mm above the ground.~~
- 
- ~~For vehicles with a maximum width not exceeding 1,300 mm above the ground not less than 250 mm.~~
- 
- ~~This distance may be increased to 2,500 1,500 mm, if the height of 1,500 1,200 mm cannot be observed due to the design, taking account of the conditions of use of the vehicle tractor and its working equipment;~~
- 6.2.4.2.1. ~~If only two dipped beam headlamps are fitted~~ **Minimum 500 mm; this value may be reduced to 350 mm for vehicles with a maximum width not exceeding 1,300 mm. and**
- 6.2.4.2.2. **Maximum 1,500 mm**
- 6.2.4.2.3. ~~This distance~~ **The above value** may be increased to ~~2,500 1,500 mm~~, if the height of ~~1,500 1,200 mm~~ **cannot** be observed due to the design, taking account of the conditions of use of the ~~vehicle~~ tractor and its working equipment ~~where the shape, structure,~~

**design or operational conditions of the vehicle and its working equipment(s) prevent compliance with the 1,500 mm value.**

- 6.2.4.2.4.** In the case of ~~vehicles tractors~~ equipped for the fitting of portable devices at the front, two **dipped-beam headlamps** ~~passing-lamps~~ in addition to the lamps mentioned in paragraph 6.2.4.2. shall be allowed at a height not exceeding 3,000 mm if the electrical connections are such that two pairs of **dipped-beam headlamps** ~~passing-lamps~~ cannot be switched on at the same time.
- 6.2.4.3.** Length: As near to the front of the ~~vehicle tractor~~ as possible; however, the light emitted must not in any circumstances cause discomfort to the driver either directly or indirectly through the **devices for indirect vision** and/or other reflecting surfaces of the ~~vehicle tractor~~.
- 6.2.5.** Geometric visibility: Defined by angles  $\alpha$  and  $\beta$  as specified in paragraph 2.10.  
 $\alpha = 15^\circ$  upwards and  $10^\circ$  downwards,  
 $\beta = 45^\circ$  outwards and  $5^\circ$  inwards.  
 Within this field, virtually the whole of the apparent surface of the lamp must be visible.  
 The presence of partitions or other items of equipment near the headlamp shall not give rise to secondary effects causing discomfort to other road users.
- 6.2.6. Orientation:** **Towards the front.**  
~~The alignment of the passing lamps must not vary according to the angle or lock of the steering.~~
- 6.2.6.1. Horizontal orientation:**
- 6.2.6.1.1.** If the height of the **dipped-beam headlamps** ~~passing-lamps~~ is equal to or greater than 500 mm and equal to or less than **1,500** ~~1,200~~ mm, it must be possible to lower the **dipped** ~~passing~~ beam by between 0.5 and **6** ~~4~~-per cent;
- 6.2.6.1.2.** **The dipped-beam headlamps must be aligned in such a way that, measured at 15 m from the lamp, the horizontal line separating the lit zone from the unlit zone is situated at a height equivalent to only half the distance between the ground and the centre of the lamp.**

~~If the height of the passing lamps is greater than 1,200 but not greater than 1,500 mm, the limit of 4 per cent laid down in paragraph 6.2.5.1. shall be increased to 6 per cent; the passing lamps referred to in paragraph 6.2.3.2.1. must be aligned in such a way that, measured at 15 m from the lamp, the horizontal line separating the lit zone from the unlit zone is situated at a height equivalent to only half the distance between the ground and the centre of the lamp.~~

~~If the dipped beam headlamps in a height above 1,500 mm are switched on, the maximum travel speed is limited to 40 km/h. Appropriate information must be given to the user.~~

**6.2.6.2. Dipped beam headlamp levelling device (optional)**

**6.2.6.2.1. A headlamp levelling device may be automatic or manually adjustable.**

**6.2.6.2.2. Devices which are adjusted manually, either continuously or non-continuously, shall have a stop position at which the lamps can be returned to the initial inclination by means of the usual adjusting screws or similar means.**

These manually adjustable devices shall be operable from the driver's seat.

Continually adjustable devices shall have reference marks indicating the loading conditions that require adjustment of the dipped-beam.

~~The number of positions on devices which are not continuously adjustable shall be such as to ensure compliance with the range of values prescribed in paragraph 6.2.6.1.1. or 6.2.6.1.2. in all the loading conditions defined in Annex 5 of Regulation No. 48.~~

**6.2.6.2.3. The dipped-beam shall not assume a position in which the dip is less than it was at original adjustment.**

~~6.2.7. May be "grouped": With the main beam headlamps driving lamps and the other front lamps.~~

~~6.2.8. May not be "combined": With any other lamp.~~

~~6.2.9. May be "reciprocally incorporated": With the main beam headlamp driving lamp;~~

~~with the other front lamps.~~

**6.2.7. Electrical connections:** The control for changing over to the **dipped passing beam** shall switch off all **main-beam headlamps driving lamps** simultaneously.

The **dipped-beam headlamps passing lamps** may remain switched on at the same time as the **main-beam headlamps driving lamps**.

**In the case where the pair of additional dipped-beam headlamps is installed (as per paragraph 6.2.2.), electrical connections shall be such that two pairs of dipped-beam headlamps are never switched on [operated] at the same time.**

- 6.2.8. "Circuit closed" tell-tale: Optional.
- 6.2.9. Other requirements: ~~The requirements of paragraph 5.5.2. shall not apply to the passing lamps.~~  
**Dipped-beam headlamps with light source(s) producing the principal dipped beam (as defined in Regulation No. 48) and having a total objective luminous flux which exceeds 2,000 lumens are prohibited.**
- 6.3. Front fog lamps
  - 6.3.1. **Presence:** **Optional.**
  - 6.3.2. Number: Two.
  - 6.3.3. Arrangement: No individual specifications.
  - 6.3.4. Position in:
    - 6.3.4.1. Width: No individual specifications.
    - 6.3.4.2. Height: No less than 250 mm above the ground. No point on the illuminating surface shall be higher than the highest point on the illuminating surface of the **dipped-beam headlamp** ~~passing lamp~~.
    - 6.3.4.3. Length: As near to the front of the **vehicle tractor** as possible; however, the light emitted must not in any circumstances cause discomfort to the driver either directly or indirectly through the **devices for indirect vision** and/or other reflecting surfaces of the **vehicle tractor**.
    - 6.3.5. Geometric visibility: Defined by angles  $\alpha$  and  $\beta$  as specified in paragraph 2.10.  
 $\alpha = 5^\circ$  upwards and downwards;  
 $\beta = 45^\circ$  outwards and  $5^\circ$  inwards.
    - 6.3.6. **Orientation:** **Towards the front.** ~~The alignment of the front fog lamps must not vary according to the angle of lock of the steering.~~  
They must be directed forwards without causing undue dazzle or discomfort to oncoming drivers and other road users.
    - ~~6.3.7. May be "grouped": With other front lamps.~~
    - ~~6.3.8. May not be "combined": With other front lamps.~~



<del>6.3.9.</del>	<del>May be "reciprocally incorporated":</del>	<del>With <b>main-beam headlamps</b> driving lamps; with the front position (side) lamps; with the parking lamps.</del>
6.3.7.	Electrical connections:	It shall be possible to switch the fog lamps on or off independently of the <b>main-beam headlamps</b> <del>driving lamps</del> and <b>dipped-beam headlamps</b> <del>passing lamps</del> and vice versa.
6.3.8.	"Circuit closed" tell-tale:	Optional.
6.4.	Reversing lamp(s)	
6.4.1.	<b>Presence:</b>	<b>[Optional.]</b>
6.4.2.	Number:	One or two.
6.4.3.	Arrangement:	No individual specifications.
6.4.4.	Position:	
6.4.4.1.	Width:	No individual specifications.
6.4.4.2.	Height:	Not less than 250 mm and not more than <b>2,500</b> <del>1,200</del> mm above the ground.
6.4.4.3.	Length:	<b>At the back of the vehicle.</b> <del>No individual specifications.</del>
6.4.5.	Geometric visibility:	Defined by angles $\alpha$ and $\beta$ as specified in paragraph 2.10. $\alpha = 15^\circ$ upwards and $5^\circ$ downwards; $\beta = 45^\circ$ to right and to left if there is only one lamp; $\beta = 45^\circ$ outwards and $30^\circ$ inwards if there are two lamps.
6.4.6.	<b>Orientation:</b>	Rearwards.
<del>6.4.7.</del>	<del>May be "grouped":</del>	<del>With any other rear lamp.</del>
<del>6.4.8.</del>	<del>May not be "combined":</del>	<del>With any other lamps.</del>
<del>6.4.9.</del>	<del>May not be "reciprocally incorporated":</del>	<del>With any other lamps.</del>
6.4.7.	Electrical connections:	It can only be lit up or remain alight if the reverse gear is engaged and if: Either the engine is running; Or one of the devices controlling the starting and stopping of the engine is in such a position that operation of the engine is possible.
6.4.8.	Tell-tale:	Optional.

- 6.5. Direction-indicator lamps (see diagrams, Annex 5).
- 6.5.1. **Presence:** **Mandatory. Types of indicators fall into categories (1, 1a, 1b, 2a, 2b~~2~~ and 5) the assembly of which on one tractor constitutes an arrangement (A to D).**
- Arrangement A shall be allowed only on tractors whose overall length does not exceed 4.60 m and in the case of which the distance between the outer edges of the illuminating surfaces is not more than 1.60 m.**
- Arrangements B, C and D shall apply to all tractors.**
- Additional direction-indicator lamps optional.**
- 6.5.2. **Number:** The number of devices shall be such that they can emit signals which correspond to one of the arrangements referred to in paragraph 6.5.3.
- 6.5.3. **Arrangement:** The number, position and horizontal visibility of the indicator lamps shall be such that they can give indications corresponding to at least one of the arrangements defined below. The angles of visibility are hatched on the diagrams; the angles shown are minimum values which may be exceeded; all the angles of visibility are measured from the centre of the illuminating surface.
- "A" Two front direction-indicator lamps (category 1, **1a or 1b**),  
Two rear direction-indicator lamps (category 2**a**).
- These lamps may be independent, grouped or combined.
- "B" Two front direction-indicator lamps (category 1, **1a or 1b**),  
Two repeating side direction-indicator lamps (category 5),  
Two rear direction-indicator lamps (category 2**a**).
- The front and repeating side lamps may be independent, grouped, or combined.
- "C" Two front direction-indicator lamps (category 1, **1a or 1b**),

Two rear direction-indicator lamps (category 2a),

Two repeating side indicator lamps (category 5)

"D" Two front direction-indicator lamps (category 1, 1a or 1b),

Two rear direction-indicator lamps (category 2a).

6.5.4. Position:

6.5.4.1. Width:

Except in the case of category 1 direction indicator lamps of arrangement "C" **and for additional direction indicator lamps**, the edge of the illuminating surface furthest from the median longitudinal plane of the **vehicle tractor** must not be more than 400 mm from the extreme outer edge of the **vehicle tractor**. The distance between the inner edges of the two illuminating surfaces of a pair of lamps shall be not less than 500 mm.

**Where the vertical distance between the rear direction-indicator lamp and the corresponding rear position (~~side~~) lamp is not more than 300 mm, the distance between the extreme outer edge of the vehicle and the outer edge of the rear direction-indicator lamp must not exceed by more than 50 mm the distance between the extreme outer edge of the vehicle and the outer edge of the corresponding rear position (~~side~~) lamp.**

For front direction-indicator lamps the illuminating surface should be not less than 40 mm from the illuminating surface of the **dipped-beam headlamps** ~~passing-lamps~~ or front fog-lamps, if any.

A smaller distance is permitted if the luminous intensity in the reference axis of the direction-indicator lamp is equal to at least 400 cd.

6.5.4.2. Height:

**Above the ground not less than 400 mm and not more than 2,500 mm and up to 4,000 mm for optional direction-indicator lamps.**

**For vehicles with a maximum width not exceeding 1,300 mm not less than 350 mm above the ground.**

~~Above the ground:~~

Not less than 500 mm for direction indicator lamps in category 5;

Not less than 400 mm for direction indicator lamps in categories 1 and 2;

Normally not more than 1,900 mm from all categories.

~~If the structure of the tractor makes it impossible to keep to this maximum figure, the highest point on the illuminating surface may be at 2,300 mm for direction indicator lamps in category 5, for those in categories 1 and 2 of arrangement "A" and for those in category 1 of arrangement "B"; it may be at 2,100 mm for those in categories 1 and 2 of the other arrangements.~~

**6.5.4.3.** Length:

The distance between the centre of reference of illuminating surface of the category 1 indicator (arrangement "B"), **category 5 indicator (arrangement "B" and "C")** and the transverse plane which marks the forward boundary of the tractor's overall length normally shall not exceed 1,800 mm. If the structure of the tractor makes it impossible to keep to the minimum angles of visibility, this distance may be increased to 2,600 mm.

~~In arrangement "C", the category 5 indicators are only required where the longitudinal distance between the centres of reference of the categories 1 and 2 indicators exceeds 6 m.~~

**6.5.5.** Geometric visibility:

**Horizontal angles:** See Annex 5 arrangement diagrams.

**Vertical angles:** 15° above and below the horizontal.

The vertical angle below the horizontal may be reduced to 10° in the case of side repeating direction-indicator lamps of arrangements "B" and "C" if their height is less than 1,900 mm. The same applies in the case of direction-indicator lamps in category 1 of arrangements "B" and "D".

**6.5.6. Orientation:**

If individual specifications for installations are laid down by the manufacturer of the lamp they must be observed.

~~6.5.7. May be "grouped": With one or more lamps, which may not be concealed.~~

~~6.5.8. May not be "combined": With another lamp, save in accordance with the arrangements referred to in paragraph 6.5.3.~~

- ~~6.5.9. May be "reciprocally incorporated":~~ ~~With a parking lamp only, but solely in the case of direction indicator lamps in category 5.~~
- 6.5.7. Electrical connections: Direction-indicator lamps shall switch on independently of the other lamps. All direction-indicator lamps on one side of a **vehicle tractor** shall be switched on and off by means of one control and shall flash in phase.
- 6.5.8. **Operational** ~~Operating~~ tell-tale: Mandatory for all direction-indicator lamps not directly visible to the driver. It may be optical or **audible auditory** or both.
- If it is optical, it shall be a **green** flashing light which, in the event of the malfunction of any of the direction-indicator lamps other than the repeating side direction-indicator lamps, is either extinguished, or remains alight without flashing, or shows a marked change of frequency.
- If it is entirely auditory, it shall be clearly audible and shall show a marked change of frequency in the event of any malfunction.
- If a tractor is equipped to tow a trailer, it must be equipped with a special optical operational tell-tale for the direction indicator lamps on the trailer unless the tell-tale of the drawing vehicle allows the failure of any one of the direction-indicator lamps on the tractor combination thus formed to be detected.
- 6.5.9. Other requirements: The lamps shall be a flashing lamp flashing  $90 \pm 30$  times per minute. Operation of the light-signal control shall be followed within not more than one second by the appearance of the light and within not more than one and one-half seconds by the first extinction.
- If a tractor is authorized to tow a trailer, the control of the direction-indicators on the tractor shall also operate the indicators of the trailer.
- In the event of failure, other than a short circuit, of one direction-indicator, the others must continue to flash but the frequency under this condition may be different from that specified.
- 6.6. Hazard warning signal
- 6.6.1. **Presence:** **Mandatory.**

<p>6.6.2. Number</p> <p>6.6.3. Arrangement</p> <p>6.6.4. Position</p> <p>6.6.4.1. Width</p> <p>6.6.4.2. Height</p> <p>6.6.4.3. Length</p> <p>6.6.5. Geometric visibility</p> <p>6.6.6. <b>Orientation</b></p> <p><del>6.6.7. May/may not be "grouped"</del></p> <p><del>6.6.8. May/may not be "combined"</del></p> <p><del>6.6.9. May/may not be "reciprocally incorporated"</del></p>	}	<p>As specified in the corresponding headings of paragraph 6.5.</p>
<p>6.6.7. Electrical connections:</p>		<p>The signal shall be operated by means of a separate control enabling all the direction-indicator lamps to function in phase.</p>
<p>6.6.8. "Circuit-closed" tell-tale:</p>		<p><b>Mandatory.</b> Flashing warning light, which can operate in conjunction with tell-tale(s) specified in paragraph 6.5.11.</p>
<p>6.6.9. Other requirements:</p>		<p>As specified in paragraph 6.5.12. If a tractor is equipped to tow a trailer the hazard-warning signal control must also be capable of activating the direction-indicator lamps on the trailer. The hazard-warning signal must be able to function even if the device which starts or stops the engine is in a position which makes it impossible to start the engine.</p>
<p>6.7. Stop lamps</p>		
<p>6.7.1. <b>Presence:</b></p>		
		<p><b>S1 or S2 of devices as described in Regulation No. 07: Mandatory on all vehicles.</b></p> <p><b>S3 or S4 of devices as described in Regulation No. 07: Optional on all vehicles.</b></p>
<p>6.7.2. Number:</p>		<p><b>Two S1 or S2 category devices and one S3 or S4 category device.</b></p>
<p>6.7.2.1.</p>		<p><b>Except in the case where a category S3 or S4 device is installed, two optional category S1 or S2 devices may be installed on vehicles.</b></p>
<p>6.7.2.2.</p>		<p><b>Only, when the median longitudinal plane of the vehicle is not located on a fixed body panel but separates one or two movable</b></p>

- parts of the vehicle (e.g. doors), and lacks sufficient space to install a single device of the S3 or S4 category on the median longitudinal plane above such movable parts, either:
- Two devices of the S3 or S4 category type "D" may be installed; or
- One device of the S3 or S4 category may be installed offset to the left or to the right of the median longitudinal plane.
- 6.7.3. Arrangement: No individual specifications.
- 6.7.4. Position:
- 6.7.4.1. Width:
- S1 or S2 categories:** The distance in between the inner edges of the apparent surfaces in the direction of the reference axes shall be not less than 500 mm apart. This distance may be reduced to 400 mm if the overall width of the vehicle ~~tractor~~ is less than 1,400 mm.
- S3 or S4 categories:** For S3 or S4 category devices: the center of reference shall be situated on the median longitudinal plane of the vehicle. However, in the case where the two devices of the S3 or S4 category are installed, according to paragraph 6.7.2., they shall be positioned as close as possible to the median longitudinal plane, one on each side of this plane.
- In the case where one S3 or S4 category lamp offset from the median longitudinal plane is permitted according to paragraph 6.7.2., this offset shall not exceed 150 mm from the median longitudinal plane to the center of reference of the lamp.
- 6.7.4.2. Height:
- S1 or S2 categories:** Above the ground, not less than 400 mm and not more than ~~2,500~~ ~~1,900~~ mm, ~~or not more than 2,100 mm if the structure of the vehicle makes it impossible to keep within 1,900 mm~~ and up to 4,000 mm for optional stop lamps.
- S3 or S4 categories:** Above the mandatory stop lamps and in the horizontal plane tangential to the lower edge of the apparent surface of a S3 or S4 category device shall be above the horizontal plane tangential to the upper edge of the apparent surface of S1 or S2 categories devices.

**Two optional category S1 or S2 devices:**

		<b>Above the ground, not less than 400 mm and not more than 4,000 mm.</b>
6.7.4.3.	Length:	
	<b>S1 or S2 categories:</b>	<b>At the rear of the vehicle.</b>
	<b>S3 or S4 categories:</b>	No individual specification.
6.7.5.	Geometric visibility:	<b>Horizontal angle:</b> 45° outwards and inwards. <b>Vertical angle:</b> 15° above and below the horizontal.  15° above and below the horizontal. The vertical angle below the horizontal may be reduced to 10° <del>if</del> <b>or 5° where the lamp is situated less than has its H plane at or below 1,900</b> <del>1,500 mm above ground, to 5° in the case of lamps less than</del> <b>respectively 750 950</b> mm <del>above from</del> the ground.
6.7.6.	<b>Orientation:</b>	Towards the rear of the vehicle.
<del>6.7.7.</del>	<del>May be "grouped":</del>	<del>With one or more other rear lamps.</del>
<del>6.7.8.</del>	<del>May not be "combined":</del>	<del>With any other lamp.</del>
<del>6.7.9.</del>	<del>May be "reciprocally incorporated":</del>	<del>With the rear position (side) lamp and the parking lamp.</del>
6.7.7.	Electrical connections:	Shall light up when the service brake is applied <b>and/or when the vehicle speed is reduced intentionally.</b>
6.7.8.	Operational tell-tale:	Optional. If fitted, it shall be a non-flashing warning lamp which comes on in the event of the malfunctioning of the stop lamps.
6.7.9.	Other requirements:	The luminous intensity of the stop lamps shall be markedly greater than that of the rear position <del>(side)</del> lamps.
6.8.	Front position <del>(side)</del> lamps	
6.8.1.	<b>Presence:</b>	<b>Mandatory.</b>
6.8.2.	Number:	Two or four (see paragraph 6.8.4.2.).
6.8.3.	Arrangement:	No individual specifications
6.8.4.	Position:	
6.8.4.1.	Width:	That point on the illuminating surface which is farthest from the <del>vehicle's tractor's</del> median longitudinal plane shall be not more than 400 mm from the extreme outer edge of the vehicle. The clearance between the respective inner edges of the two illuminating surfaces shall be not less than 500 mm.



- 6.8.4.2. Height: Above the ground, not less than 400 mm and not more than ~~2,500~~ 1,900 mm, or not more than 2,100 mm if the structure of the vehicle makes it impossible to keep within 1,900 mm.
- In the case of ~~vehicles tractors~~ equipped for the fitting of portable devices at the front, which may obscure the mandatory front position ~~(side)~~ lamps, two additional front position ~~(side)~~ lamps may be fitted at a height not exceeding ~~4,000~~ 3,000 mm.
- 6.8.4.3. Length: No specifications provided that the lamps are aligned forwards and the angles of geometrical visibility specified in paragraph 6.8.5. are complied with.
- 6.8.5. Geometric visibility: **Horizontal angle:** For the two front position ~~(side)~~ lamps: 10° inwards and 80° outwards. However, the angle of 10° inwards may be reduced to 5° if the shape of the bodywork makes it impossible to keep to 10°. For ~~vehicles tractors~~ with any overall width not exceeding 1,400 mm this angle may be reduced to 3° if the shape of the bodywork makes it impossible to keep to 10°.
- Vertical angle:** 15° above and below the horizontal. The vertical angle below the horizontal may be reduced to 10° if the height of the lamp above the ground is less than 1,900 mm, and to 5° if this height is less than 750 mm.
- 6.8.6. **Orientation:** Towards the front.
- ~~6.8.7. May be "grouped": With any other front lamp.~~
- ~~6.8.8. May not be "combined": With other lamps.~~
- ~~6.8.9. May be "reciprocally incorporated": With any other front lamps.~~
- 6.8.7. Electrical connections: No individual specifications (**see paragraph 5.11**).
- 6.8.8. Tell-tale: Mandatory. This tell-tale shall be non-flashing. It shall not be required if the instrument panel lighting can only be turned on simultaneously with the front position ~~(side)~~ lamps.
- 6.9. Rear position ~~(side)~~ lamps
- 6.9.1. **Presence:** **Mandatory.**
- 6.9.2. Number: **Two or more (see paragraphs 6.9.4.3 and 6.9.5.1).**

- 6.9.3. Arrangement: No individual specifications. **If four rear position ~~(side)~~ lamps according to paragraph 6.9.5.1 are fitted, at least one pair of rear position ~~(side)~~ lamps shall be fixed.**
- 6.9.4. Position:
- 6.9.4.1. Width: **Except as provided in paragraphs 6.9.5.1.** that point on the illuminating surface which is farthest from the ~~vehicle's tractor's~~ median longitudinal plane shall be not more than 400 mm from the extreme outer edge of the ~~vehicle tractor~~.
- The distance between the inner edges of the two illuminating surfaces shall be not less than 500 mm. This distance may be reduced to 400 mm where the overall width of the ~~vehicle tractor~~ is less than 1,400 mm.
- 6.9.4.2. Height: **Except as provided in paragraph 6.9.5.1.** above the ground not less than 400 mm and not more than ~~2,500~~ ~~1,900~~ mm (~~in exceptional cases not more than 2,100 mm if it is impossible to keep within 1,900 mm~~).
- For vehicles with a maximum width not exceeding 1,300 mm above the ground not less than 250 mm.**
- 6.9.4.3. Length: **At the rear of vehicle. Not more than 1,000 mm from the rearmost point of the vehicle.**
- Parts of the vehicle that extend the rearmost point of the illuminating surface of the rear position ~~(side)~~ lamps by more than 1000 mm shall be fitted with an additional rear position ~~(side)~~ lamp.**
- ~~No individual specification.~~
- 6.9.5. Geometric visibility: **Horizontal angle:** For the two rear position ~~(side)~~ lamps: either 45° inwards and 80° outwards, or 80° inwards and 45° outwards.
- Vertical angle:** 15° above and below the horizontal. The angle below the horizontal may be reduced to 10° if the height of the lamp above the ground is less than ~~1,900~~ ~~1,500~~ mm, and to 5° if this height is less than 750 mm.
- 6.9.5.1. **If it is impossible to observe the above position and visibility requirements, four rear position lamps may be fitted in accordance with the following installation specifications:**

- 6.9.5.1.1. Two rear position lamps must keep within the maximum height of 2,500 mm above the ground.  
A distance of at least 300 mm between the rear reflectors must be observed, and they must have a vertical angle of visibility above the horizontal of 15°.
- 6.9.5.1.2. The other two shall keep within a maximum height of 4,000 mm above the ground and shall be bound by the requirements of paragraph 6.9.4.1.
- 6.9.6. **Orientation:** Towards the rear.
- ~~6.9.7. May be "grouped": With any other rear lamp.~~
- ~~6.9.8. May be "combined": With the rear registration-plate lamp.~~
- ~~6.9.9. May be "reciprocally incorporated": With the stop lamps, the rear fog lamp or the parking lamp.~~
- 6.9.7. Electrical connections: No individual specifications.
- 6.9.8. "Circuit closed" tell-tale: **Mandatory (see 5.11). It must** be combined with that of the front position (~~side~~) lamps. ~~Color: amber or yellow.~~
- 6.10. Rear fog-lamps
- 6.10.1. **Presence:** **Optional.**
- 6.10.2. Number: One or two.
- 6.10.3. Arrangement: This must satisfy the conditions of geometric visibility.
- 6.10.4. Position:
- 6.10.4.1. Width: If there is only one rear fog lamp, it must be on the opposite side of the median longitudinal plane of the ~~vehicle tractor~~ to the direction of traffic prescribed in the country of registration. In all cases the distance between the rear fog-lamp and the stop lamp shall be more than 100 mm.
- 6.10.4.2. Height: Above the ground, not less than **400** ~~250~~ mm **and** not more than **2,500** ~~1,900~~ mm, ~~or not more than 2,100 mm if the shape of the bodywork makes it impossible to keep within 1,900 mm.~~
- 6.10.4.3. Length: **At the rear of vehicle.** ~~No individual specification.~~
- 6.10.5. Geometric visibility: **Horizontal angle:** 25° inwards and outwards.  
**Vertical angle:** 5° above and below the horizontal.

6.10.6.	<b>Orientation:</b>	Towards the rear.
<del>6.10.7.</del>	<del>May be "grouped":</del>	<del>With any other rear lamp.</del>
<del>6.10.8.</del>	<del>May not be "combined":</del>	<del>With any other lamps.</del>
<del>6.10.9.</del>	<del>May be "reciprocally incorporated":</del>	<del>With the rear position (side) lamps or the parking lamp.</del>
6.10.7.	Electrical connections:	<p>These must be such that the rear fog-lamp can <b>light up</b> <del>operate</del> only when the <b>dipped-beam headlamps</b> <del>passing lamps</del> or the front fog-lamps or a combination of these are <b>switched on in use</b>.</p> <p>If the front fog-lamps exist, the extinguishing of the rear fog-lamp must be possible independently from that of the front fog-lamps.</p>
6.10.8.	"Circuit closed" tell-tale:	Mandatory. An independent, fixed-intensity <b>warning signal</b> light.
6.11.	Parking lamps	
6.11.1.	<b>Presence:</b>	<b>Optional.</b>
6.11.2.	Number:	Dependent upon the arrangement.
6.11.3.	Arrangement:	Either two front lamps and two rear lamps, or one lamp on each side.
6.11.4.	Position:	
6.11.4.1.	Width:	That point on the illuminating surface which is farthest from the <b>vehicles tractors</b> median longitudinal plane shall not be more than 400 mm from the extreme outer edge of the <b>vehicle tractor</b> . Furthermore, in the case of a pair of lamps, the lamps must be <b>on the side</b> of the <b>vehicle</b> <del>symmetrical to the median longitudinal plane of the tractor</del> .
6.11.4.2.	Height:	Above the ground, not less than 400 mm and not more than <b>2,500</b> <del>1,900</del> mm ( <del>not more than 2,100 mm if the design of the bodywork makes it impossible to keep within 1,900 mm</del> ).
6.11.4.3.	Length:	No individual specifications.
6.11.5.	Geometric visibility:	<p><b>Horizontal angle:</b> 45° outwards, towards the front and towards the rear.</p> <p><b>Vertical angle:</b> 15° above and below the horizontal. The vertical angle below the horizontal may be reduced to 10° if the height of the lamp above the ground is less than <b>1,500</b> <del>1,900</del> mm; and to 5° if this height is less than 750 mm.</p>

6.11.6.	<b>Orientation:</b>	Such that the lamps meet the requirements concerning visibility towards the front and towards the rear.
<del>6.11.7.</del>	<del>May be "grouped":</del>	<del>With any other lamp.</del>
<del>6.11.8.</del>	<del>May not be "combined":</del>	<del>With any other lamp.</del>
<del>6.11.9.</del>	<del>May be "reciprocally incorporated":</del>	<del>At the front with the front position (side) lamps, the <b>dipped beam headlamps</b> passing lamps, the <b>main beam headlamps</b> driving-lamps and the front fog lamps.</del>
		<del>At the rear, with the rear position (side) lamps, the stop lamps and the rear fog lamps.</del>
		<del>With the direction indicator lamps in category 5.</del>
6.11.7.	Electrical connections:	The connections must allow the parking lamp(s) on the same side of the <b>vehicle tractor</b> to be lit independently of any other lamps.
6.11.8.	Tell-tale:	Optional. If there is one, it must not be possible to confuse it with the tell-tale for the position ( <del>side</del> ) lamps.
6.11.9.	Other requirements:	The function of this lamp may also be performed by the simultaneous switching on of the front and rear position ( <del>side</del> ) lamps on one side of the <b>vehicle tractor</b> .
6.12.	End-outline marker lamps	
6.12.1.	<b>Presence:</b>	<b>Optional on vehicles exceeding 2.10 m in width. Prohibited on all other vehicles.</b>
6.12.2.	Number:	Two visible from the front and two visible from the rear.
6.12.3.	Arrangement:	No individual specifications.
6.12.4.	Position:	
6.12.4.1.	Width:	As close as possible to the extreme outer edge of the <b>vehicle tractor</b> .
6.12.4.2.	Height:	At the greatest height compatible with the required position in width and with symmetry of the lamps.
6.12.4.3.	Length:	No individual specification.
6.12.5.	Geometric visibility:	<b>Horizontal angle:</b> 80° outwards. <b>Vertical angle:</b> 5° above and 20° below the horizontal.

<p><b>6.12.6. Orientation:</b></p> <p><del>6.12.7. May not be "grouped"</del></p> <p><del>6.12.8. May not be "combined"</del></p> <p><del>6.12.9. May not be "reciprocally incorporated"</del></p> <p><b>6.12.7. Electrical connections:</b></p> <p><b>6.12.8. Tell-tale:</b></p> <p><b>6.12.9. Other requirements:</b></p>	<p>Such that the lamps meet the requirements concerning visibility towards the front and towards the rear.</p>
<p><del>6.13. Work lamp(s)</del></p> <p><b>6.13.1. Presence:</b></p> <p><b>6.13.2. Number</b></p> <p><b>6.13.3. Arrangement</b></p> <p><b>6.13.4. Position</b></p> <p><b>6.13.5. Geometric visibility</b></p> <p><b>6.13.6. Orientation</b></p> <p><del>6.13.7. May be "grouped"</del></p> <p><del>6.13.8. May not be "combined"</del></p> <p><del>6.13.9. May not be "reciprocally incorporated"</del></p> <p><b>6.13.7. Electrical connections:</b></p> <p><b>6.13.8. Tell-tale:</b></p> <p><b>6.14. Rear retro-reflectors, non triangular</b></p> <p><b>6.14.1. Presence:</b></p> <p><b>6.14.2. Number:</b></p> <p><b>6.14.3. Arrangement:</b></p>	<p><del>With any other lamps, except for the case referred to in paragraph 6.8.4.2.</del></p> <p>No individual specifications.</p> <p><del>Optional. Mandatory.</del></p> <p>Subject to all the other conditions being met, the lamp visible from in front and the lamp visible from the rear, on the same side of the <del>vehicle tractor</del>, may be included in one device. The position of an end-outline marker lamp in relation to the corresponding position <del>(side)</del> lamp shall be such that the distance between the projections on a transverse vertical plane of the points nearest to one another of the illuminating surfaces of the two lamps considered is not less than 200 mm.</p> <p><b>Optional.</b></p> <p>No individual specifications.</p> <p><del>With another lamp.</del></p> <p>This lamp <del>may</del> <b>shall</b> be operated independently of all other lamps <b>in view of the fact that it does not illuminate the road or act as a signalling device on the road.</b></p> <p>Mandatory.</p> <p><b>Mandatory.</b></p> <p>Two or four <b>(see paragraph 6.14.5.1).</b></p> <p>No individual specifications.</p>

- 6.14.4.** Position:
- 6.14.4.1.** Width: Except as provided in paragraph 6.14.5.1. the point on the illuminating surface which is farthest from the ~~vehicle's tractor's~~ median longitudinal plane shall be not more than 400 mm from the extreme outer edge of the ~~vehicle tractor~~. The inner edges of the **retro-reflectors** shall be not less than 600 mm apart. This distance may be reduced to 400 mm where the overall width of the ~~vehicle tractor~~ is less than 1,300 mm.
- 6.14.4.2.** Height: Except as provided in paragraph 6.14.5.1., not less than 400 mm and not more than 900 mm above the ground.
- For vehicles with a maximum width not exceeding 1,300 mm above the ground not less than 250 mm.**
- However, the upper limit may be increased to not more than 1,200 mm if it is impossible to keep within the height of 900 mm without having to use fixing devices liable to be easily damaged or bent.
- 6.14.4.3.** Length: No individual specifications.
- 6.14.5.** Geometric visibility: **Horizontal angle:** 30° inwards and outwards.
- Vertical angle:** 15° above and below the horizontal. The vertical angle below the horizontal may be reduced to 5° if the height of the reflector is less than 750 mm.
- 6.14.5.1.** If it is impossible to observe the above position and visibility requirements, four retro-reflectors may be fitted in accordance with the following installation specifications:
- 6.14.5.1.1.** Two retro-reflectors must keep within the maximum height of 900 mm above the ground. However, this upper limit may be increased to not more than 1,200 mm if it is impossible to keep within the height of 900 mm without having to use fixing devices liable to be easily damaged or bent.
- A distance of at least 300 mm between the interior edges of the reflectors must be observed, and they must have a vertical angle of visibility above the horizontal of 15°.
- 6.14.5.1.2.** The other two shall keep within a maximum height of **2,500** ~~2,100~~ mm above the ground and shall be bound by the requirements of paragraph 6.14.4.1.

- 6.14.6. **Orientation:** Towards the rear.
- ~~6.14.7. **May be "grouped":** ~~With any other lamp.~~~~
- 6.14.7. Other requirements: The illuminating surface of the retro-reflector may have parts in common with that of any other rear lamp.
- 6.15. **Non triangular side retro-reflectors**
- 6.15.1. **Presence:** **Mandatory on all tractors the length of which exceeds 6 m.**  
**Optional on tractors the length of which does not exceed 6 m.**
- 6.15.2. Number: Two or four.
- 6.15.3. Arrangement: One or two each side of tractor where over-all length of ~~vehicle tractor~~ **is**  $\leq 6$  m. Two each side of tractor where over-all length of ~~vehicle tractor~~ **is**  $> 6$  m. The reflecting surface must be mounted in a vertical plane (maximum deviation  $10^\circ$ ) parallel to the longitudinal axis of the vehicle.
- 6.15.4. Position:
- 6.15.4.1. Width: No individual specification.
- 6.15.4.2. Height: Not less than 400 mm and not more than 900 mm above the ground.  
However, the upper limit may be increased to not more than ~~1,500~~ ~~1,200~~ mm if it is impossible to keep within the height of 900 mm without having to use fixing devices liable to be easily damaged or bent.
- 6.15.4.3. Length: One reflector must be not more than 3 m from the foremost point of the tractor, and either the same reflector or a second reflector must be not more than 3 m from the rearmost point of the tractor. The distance between two reflectors on the same side of the tractor must not exceed 6 m.
- 6.15.5. Geometric visibility: **Horizontal angle:**  $20^\circ$  forwards and rearwards.  
**Vertical angle:**  $10^\circ$  above and below the horizontal. The vertical angle below the horizontal may be reduced to  $5^\circ$  if the length of the reflector is less than 750 mm.
- 6.15.4.6. **Alignemnt:** **Towards the side.**
- 6.16. **Rear registration plate lamp(s)**
- 6.16.1. **Presence:** **Optional.**



6.16.2.	Number	
6.16.3.	Arrangement	
6.16.4.	Position	
6.16.4.1.	Width	Such that the device is able to illuminate the site of the registration plate.
6.16.4.2.	Height	
6.16.4.3.	Length	
6.16.5.	Geometric visibility	
6.16.6.	<b>Orientation</b>	
<del>6.16.7.</del>	<del>May be "grouped":</del>	<del>With one or more rear lamps.</del>
<del>6.16.8.</del>	<del>May be "combined":</del>	<del>With the rear position (side) lamps.</del>
<del>6.16.9.</del>	<del>May not be "reciprocally incorporated":</del>	<del>With any other lamp.</del>
6.16.7.	Tell-tale:	Optional. If provided, its function shall be performed by the tell-tale prescribed for the front and rear position (side) lamps.
6.16.8.	Electrical connections:	The device shall light up only at the same time as the rear position (side) lamps (see paragraph 5.11).
6.17.	<b>Front retro-reflectors, non triangular</b>	
6.17.1.	<b>Presence:</b>	<b>Mandatory on tractors having all forward facing lamps with reflectors concealable.</b> <b>Optional on all other vehicles.</b> <b>Not necessary on vehicles fitted with signaling panels (paragraph 6.24) or conspicuity markings (paragraph 6.21).</b>
6.17.2.	<b>Number:</b>	<b>Two or four.</b>
6.17.3.	<b>Arrangement:</b>	<b>No special requirement.</b>
6.17.4.	<b>Position</b>	
6.17.4.1.	<b>Width:</b>	<b>That point on the illuminating surface which is farthest from the vehicle's median longitudinal plane shall not be more than 400 mm from the extreme outer edge of the vehicle.</b> <b>The distance between the inner edges of the two apparent surfaces in the direction of the reference axes shall be not less than 600 mm. This distance may be reduced to 400 mm where the overall width of the vehicle is less than 1,300 mm.</b>
6.17.4.2.	<b>Height:</b>	<b>Above the ground, not less than 300 mm nor more than 1500 mm. If this is not possible due to the design the front</b>

		reflectors shall be arranged as low as possible.
6.17.4.3.	Length:	At the front of the vehicle.
6.17.5.	Geometric visibility:	
	Horizontal angle:	30° inwards and outwards. In the case of trailers or towed machines, the angle inwards may be reduced to 10°. If because of the construction of the trailers or towed machines, this angle cannot be met by the mandatory retro-reflectors, then additional (supplementary) retro-reflectors shall be fitted, without the width limitation (paragraph 6.18.4.1.), which shall, in conjunction with the mandatory retro-reflectors, give the necessary visibility angle.
	Vertical angle:	10° above and below the horizontal. The vertical angle below the horizontal may be reduced to 5° in the case of a retro-reflector less than 750 mm above the ground.
6.17.5.1.		If it is impossible to observe the above position and visibility requirements, four front retro reflectors may be fitted in accordance with the following installation specifications:
6.17.5.1.1.		Two front retro reflectors must keep within the maximum height of 1,200 mm above the ground.  A distance of at least 300 mm between the rear reflectors must be observed, and they must have a vertical angle of visibility above the horizontal of 15°.
6.17.6.	Orientation:	Towards the front.
6.17.7.	Other requirements:	The illuminating surface of the retro-reflector may have parts in common with the apparent surface of any other lamp situated at the front.
6.18.	Side-marker lamps	
6.18.1.	Presence:	Optional.
6.18.2.	Minimum number per side:	Such that the rules for longitudinal positioning are complied with.
6.18.3.	Arrangement:	No individual specifications.
6.18.4.	Position:	
6.18.4.1.	Width:	No individual specifications.

- 6.18.4.2. **Height:** Above the ground, not less than 250 mm nor more than 2,500 mm.
- 6.18.4.3. **Length:** At least one side-marker lamp shall be fitted to the middle third of the vehicle, the foremost side-marker lamp being not further than 3 m from the front. The distance between two adjacent side-marker lamps shall not exceed 3 m. If the structure, design or the operational use of the vehicle makes it impossible to comply with such a requirement, this distance may be increased to 4 m.
- The distance between the rearmost side-marker lamp and the rear of the vehicle shall not exceed 1 m.
- However, for vehicles the length of which does not exceed 6 m and for chassis-cabs, it is sufficient to have one side-marker lamp fitted within the first third and/or within the last third of the vehicle length.
- 6.18.5. **Geometric visibility**
- Horizontal angle:** 45° to the front and to the rear; however, this value can be reduced to 30°.
- Vertical angle:** 10° above and below the horizontal. The vertical angle below the horizontal may be reduced to 5° in the case of a side-marker lamp less than 750 mm above the ground.
- 6.18.6. **Orientation:** Towards the side.
- 6.18.7. **Electrical connections:** No individual specifications (see paragraph 5.11).
- 6.18.8. **Tell-tale:** Optional. If it exists its function shall be carried out by the tell-tale required for the front and rear position lamps.
- 6.18.9. **Other requirements:** When the rearmost side-marker lamp is combined with the rear position lamp reciprocally incorporated with the rear fog-lamp or stop lamp, the photometric characteristics of the side-marker lamp may be modified during the illumination of the rear fog lamp or stop lamp.
- Rearmost side-marker lamps shall be amber if they flash with the rear direction-indicator lamp.
- 6.19. **Daytime running lamp**
- 6.19.1. **Presence:** Optional.
- 6.19.2. **Number:** Two or four (see paragraph 6.20.4.2).

6.19.3.	<b>Arrangement:</b>	No special requirement.
6.19.4.	<b>Position</b>	
6.19.4.1.	<b>Width:</b>	No individual specifications.
6.19.4.2.	<b>Height:</b>	Above the ground not less than 250 mm not more than 2,500 mm.  In the case of tractors equipped for the fitting of portable devices at the front, two Daytime Running Lamp (DRL) lamps in addition to the lamps mentioned in paragraph 6.20.4.2 shall be allowed at a height not exceeding 4,000 mm if the electrical connections are such that two pairs of DRL lamps cannot be switched on at the same time.
6.19.4.3.	<b>Length:</b>	At the front of the vehicle. This requirement shall be deemed to be satisfied if the light emitted does not cause discomfort to the driver either directly, or indirectly through the devices for indirect vision and/or other reflecting surfaces of the vehicle.
6.19.5.	<b>Geometric visibility</b>	
	<b>Horizontal:</b>	outwards 20° and inwards 20°.
	<b>Vertical:</b>	upwards 10° and downwards 10°.
6.19.6.	<b>Orientation:</b>	Towards the front.
6.19.7.	<b>Electrical connections</b>	
6.19.7.1.		The daytime running lamps shall be switched ON automatically when the device which starts and/or stops the engine is in a position which makes it possible for the engine to operate. However, daytime running lamps may remain OFF while the automatic transmission control is in the park or neutral position, while the parking brake is applied or after the propulsion system is activated but the vehicle was not set in motion for the first time.  The daytime running lamps shall switch OFF automatically when the front fog lamps or headlamps are switched ON, except when the latter are used to give intermittent luminous warnings at short intervals.  Furthermore, the lamps referred to in paragraph 5.11. are not switched ON when

		the daytime running lamps are switched ON.
6.19.7.2.		<p>If the distance between the front direction-indicator lamp and the daytime running lamp is equal or less than 40 mm, the electrical connections of the daytime running lamp on the relevant side of the vehicle may be such that either:</p> <p>(a) It is switched OFF; or</p> <p>(b) Its luminous intensity is reduced during the entire period (both ON and OFF cycle) of activation of a front direction-indicator lamp.</p>
6.19.7.3.		<p>If a direction-indicator lamp is reciprocally incorporated with a daytime running lamp, the electrical connections of the daytime running lamp on the relevant side of the vehicle shall be such that the daytime running lamp is switched OFF during the entire period (both ON and OFF cycle) of activation of the direction-indicator lamp.</p>
6.19.8.	Tell-tale:	Closed-circuit tell-tale optional.
6.20.	Cornering lamp	
6.20.1	Presence:	Optional.
6.20.2.	Number:	Two or four.
6.20.3.	Arrangement:	No special requirement.
6.20.4.	Position	
6.20.4.1.	Width:	No individual specifications.
6.20.4.2.	Length:	Not further than 1,000 mm from the front.
6.20.4.3.	Height:	<p>Above the ground not less than 250 mm nor more than 2,500 mm and up to 3,000 mm for two additional cornering lamps in the case of vehicles equipped for the fitting of portable devices at the front, which may obscure the cornering lamp.</p> <p>However, no point on the apparent surface in the direction of the reference axis shall be higher than the highest point on the apparent surface in the direction of the reference axis of the dipped-beam headlamp.</p>
6.20.5.	Geometric visibility	
	Horizontal:	30° to 60° outwards.
	Vertical:	10° upwards and downwards.

6.20.6.	<b>Orientation:</b>	Such that the lamps meet the requirements for geometric visibility.
6.20.7.	Electrical connections	The cornering lamps shall be so connected that they cannot be activated unless the main-beam headlamps or the dipped-beam headlamps are switched ON at the same time.
6.20.7.1.		The cornering lamp on one side of the vehicle may only be switched ON automatically when the direction-indicators on the same side of the vehicle are switched ON and/or when the steering angle is changed from the straight-ahead position towards the same side of the vehicle.  The cornering lamp shall be switched OFF automatically when the direction-indicator is switched OFF and/or the steering angle has returned in the straight-ahead position.
6.20.7.2.		When the reversing lamp is switched ON, both cornering lamps may be switched on simultaneously, independently from the steering wheel or direction-indicator position. In this case, the cornering lamps shall be switched OFF when the reversing lamp is switched OFF.
6.20.8.	Tell-tale:	None.
6.20.9.	Other requirements:	The cornering lamps shall not be activated at vehicle speeds above 40 km/h.
6.21.	Conspicuity markings	
6.22.1.	Presence:	Optional.
6.21.2.	Number:	According to the presence.
6.21.3.	Arrangement:	The conspicuity markings shall be as close as practicable to horizontal and vertical, compatible with the shape, structure, design and operational requirements of the vehicle.
6.21.4.	Position:	No individual specifications.
6.21.5.	Geometric visibility:	No individual specifications.
6.21.6.	<b>Orientation:</b>	No individual specifications.
6.22.	Emergency stop signal	
6.22.1.	Presence:	Optional. The emergency stop signal shall be given by the simultaneous operation of

		all the stop or direction-indicator lamps fitted.
6.22.2.	Number:	As specified in paragraph 6.5.2. or 6.7.2.
6.22.3.	Arrangement:	As specified in paragraph 6.5.3. or 6.7.3.
6.22.4.	Position:	As specified in paragraph 6.5.4. or 6.7.4.
6.22.5.	Geometric visibility:	As specified in paragraph 6.5.5. or 6.7.5.
6.22.6.	Orientation:	As specified in paragraph 6.5.6. or 6.7.6.
6.22.7.	Electrical connections:	
6.22.7.1.		All the lamps of the emergency stop signal shall flash in phase at a frequency of $4.0 \pm 1.0$ Hz.
6.22.7.1.1.		However, if any of the lamps of the emergency stop signal to the rear of the vehicle use filament light sources the frequency shall be $4.0 +0.0/-1.0$ Hz.
6.22.7.2.		The emergency stop signal shall operate independently of other lamps.
6.22.7.3.		The emergency stop signal shall be activated and deactivated automatically.
6.22.7.3.1.		The emergency stop signal shall be activated only when the vehicle speed is above 20 km/h and the deceleration is at least $4 \text{ m/s}^2$ .
6.22.7.3.2.		The emergency stop signal shall be automatically deactivated when the deceleration falls below $2,5 \text{ m/s}^2$ .
6.22.8.	Tell-tale:	Optional
6.22.9.	Other requirements	
6.22.9.1.		Except as provided in paragraph 6.23.9.2. below, if a tractor is equipped to tow a trailer or a towed machine, the control of the emergency stop signal on the tractor shall also be capable of operating the emergency stop signal on the trailer or towed machine.  When the tractor is electrically connected to a trailer or towed machine, the operating frequency of the emergency stop signal for the combination shall be limited to the frequency specified in paragraph 6.22.7.1.1. However, if the tractor can detect that filament light sources are not being used on the trailer or towed machine for the emergency stop

		signal, the frequency may be that specified in paragraph 6.22.7.1.
6.22.9.2.		If a tractor is equipped to tow a trailer or towed machine fitted with a service braking system of either continuous or semi-continuous type, it shall be ensured that a constant power supply is provided via the electrical connector for the stop lamps to such trailers or towed machines while the service brake is applied.
6.23.	<b>Signalling panel</b>	
6.23.1.	<b>Presence:</b>	Mandatory on tractors with a total width of more than 2.75 m (including tyres) or if external projections of the vehicle have to be marked. The latter should be determined in agreement with the manufacturer, the Technical Service and the responsible approval authority.
6.23.2.	<b>Number:</b>	Two or four (see Annexes 6 and 7).
6.23.3.	<b>Arrangement:</b>	The panels shall be arranged in a way that their stripes shall run under 45° outwards and downwards.
6.23.4.	<b>Position:</b>	
	<b>Width:</b>	That point on the illuminating surface which is farthest from the vehicle's median longitudinal plane shall not be more than 100 mm from the extreme outer edge of the vehicle. This value may be increased if the shape of the bodywork makes it impossible to keep within 100 mm.
	<b>Height:</b>	No individual specifications.
	<b>Length:</b>	No individual specifications.
6.23.5.	<b>Geometric visibility</b>	No individual specifications.
6.23.6.	<b>Orientation:</b>	Towards the front and the rear.
6.24.	<b>SMV rear marking plate</b>	
6.24.1.	<b>Presence:</b>	Optional on vehicles with a maximum design speed of not more than 40 km/h. Prohibited on all other vehicles.
6.24.2.	<b>Number:</b>	According to Annex 15 of Regulation No. 69.
6.24.3.	<b>Arrangement:</b>	According to Annex 15 of Regulation No. 69.
6.24.4.	<b>Position</b>	
	<b>Width:</b>	According to Annex 15 of Regulation No. 69.



	<b>Height:</b>	No individual specifications.
	<b>Length:</b>	According to Annex 15 of Regulation No. 69.
6.24.5.	<b>Geometric visibility</b>	According to Annex 15 of Regulation No. 69.
6.24.6.	<b>Orientation:</b>	According to Annex 15 of Regulation No. 69.
<del>6.25. Lane keeping lamps (Regulation No. 7)</del>		
<del>6.25.1. Presence: Optional.</del>		
<del>6.25.2. Number: Two visible from the front.</del>		
<del>6.25.3. Arrangement: Protruding at every side of the rear.</del>		
<del>6.25.4. Position:</del>		
<del>6.25.4.1. Width: No individual specification.</del>		
<del>6.25.4.2. Height: As low as possible between 400 mm and 2,500 mm.</del>		
<del>6.25.4.3. Length: At the rear of the vehicle.</del>		
<del>6.25.5. Geometric visibility: From the front of the vehicle horizontal along both sides (for seeing in the rearview mirror).</del>		
<del>6.25.6. Alignment: Such that the lamps meet the requirements concerning visibility towards the front.</del>		
<del>6.25.7. May not be "grouped"</del>		
<del>6.25.8. May not be "combined"</del>		
<del>6.25.9. May not be "reciprocally incorporated": With any other lamps.</del>		
<del>6.25.10. Electrical connections: No individual specifications (see paragraph 5.11).</del>		
<del>6.25.11. Tell-tale: No individual specification.</del>		
<del>6.25.12. Other requirements: The light emitted must not in any circumstances cause discomfort to the driver either directly or indirectly through the rear-view mirrors nor to other road users.</del>		
6.25.	<b>Exterior Courtesy Lamp</b>	
6.25.1.	<b>Presence:</b>	Optional.
6.25.2.	<b>Number:</b>	No individual specifications.
6.25.3.	<b>Arrangement:</b>	No individual specifications.
6.25.4.	<b>Position:</b>	No individual specifications.
6.25.5.	<b>Geometric visibility:</b>	No individual specifications.
6.25.6.	<b>Orientation:</b>	No individual specifications.
6.25.7.	<b>Electrical connections:</b>	No individual specifications.

- 6.25.8. Tell-tale:** No individual specifications.
- 6.25.9. Other requirements:** The exterior courtesy lamp shall not be activated unless the vehicle is stationary and one or more of the following conditions is satisfied:
- (a) The engine is stopped; or
  - (b) A driver or passenger door is opened; or
  - (c) A load compartment door is opened.
- The provisions of paragraph 5.10. shall be met in all fixed positions of use.
- 6.26. Manoeuvring lamps (Regulation No. 23)**
- 6.26.1. Presence**  
Optional on motor vehicles.
- 6.26.2. Number**  
One or two (one per side)
- 6.26.3. Arrangement**  
No special requirement, however the requirements of paragraph 6.26.9. apply.
- 6.26.4. Position**  
No special requirement.
- 6.26.5. Geometric Visibility**  
No special requirement.
- 6.26.6. Orientation**  
Downwards, however the requirements of paragraph 6.26.9. apply.
- 6.26.7. Electrical Connections**  
Manoeuvring lamps shall be so connected that they cannot be activated unless the main-beam headlamps or the dipped-beam headlamps are switched ON at the same time.
- The manoeuvring lamp(s) shall be activated automatically for slow manoeuvres up to 10 km/h provided that one of the following conditions is fulfilled:
- (a) Prior to the vehicle being set in motion for the first time after each manual activation of the propulsion system; or
  - (b) Reverse gear is engaged; or
  - (c) A camera based system which assists parking manoeuvres is activated
- The manoeuvring lamps shall be automatically switched off if the forward speed of the vehicle exceeds 10 km/h and they shall remain switched off until the conditions for activation are met again.

- 6.26.8. Tell-tale**  
**No special requirement.**
- 6.26.9. Other requirements**
- 6.26.9.1. The Technical Service shall, to the satisfaction of the authority responsible for type-approval, perform a visual test to verify that there is no direct visibility of the apparent surface of these lamps, if viewed by an observer moving on the boundary of a zone on a transverse plane 10 m from the front of the vehicle, a transverse plane 10 m from the rear of the vehicle, and two longitudinal planes 10 m from each side of the vehicle; these four planes to extend from 1 m to 3 m above and parallel to the ground as shown in Annex 14 of Regulation No. 48.**
- 6.26.9.2. At the request of the applicant and with the consent of the Technical Service the requirement of 6.26.9.1 may be verified by a drawing or simulation or deemed be satisfied if the installation conditions comply with paragraph 6.2.3 of Regulation No. 23, as noticed in the communication document in Annex 1, paragraph 9.**

## **7. Modification and extension of approval of the vehicle type or of the installation of its lighting and light-signalling devices**

- 7.1. Every modification of the vehicle type, or of the installation of its lighting or light-signalling devices, or of the list referred to in paragraph 3.2.2. above, shall be communicated to the administrative department which approved that vehicle type. The department may then either:
- 7.1.1. Consider that the modifications made are unlikely to have an appreciable adverse effect and that in any case the vehicle still meets the requirements; or
- 7.1.2. Require a further test report from the technical service responsible for conducting the tests.
- 7.2. Confirmation or refusal of approval, specifying the alterations, shall be communicated by the procedure specified in paragraph 4.3. above to the Parties to the Agreement applying this Regulation.
- 7.3. The competent authority issuing the extension of approval shall assign a series number for such an extension and inform thereof the other Parties to the 1958 Agreement applying this Regulation by means of a communication form conforming to the model in Annex 1 to this Regulation.

**8. Conformity of production**

- 8.1. Every vehicle bearing an approval mark as prescribed by this Regulation shall conform, as regards the installation of lighting and light-signalling devices and their characteristics, to the vehicle type approved.
- 8.2. In order to verify conformity as prescribed in paragraph 8.1. above, a sufficient number of random checks shall be made on serially manufactured vehicles bearing the approval mark required by this Regulation.

**9. Penalties for non-conformity of production**

- 9.1. The approval granted in respect of a vehicle type pursuant to this Regulation may be withdrawn if the requirements laid down in paragraph 8.1. above are not complied with or if the vehicle or vehicles taken fail to pass the tests prescribed in paragraph 8. above.
- 9.2. If a Party to the Agreement applying this Regulation withdraws an approval it has previously granted, it shall forthwith so notify the other Contracting Parties applying this Regulation, by means of a communication form conforming to the model in Annex 1 to this Regulation.

**10. Production definitely discontinued**

If the holder of the approval completely ceases to manufacture a type of vehicle under the Regulation, he shall inform thereof the authority which granted the approval. Upon receiving the relevant communication that authority shall inform the other Contracting Parties which apply this Regulation thereof, by means of a communication form conforming to the model in Annex 1 to this Regulation.

**11. Names and addresses of technical services responsible for conducting approval tests, and of administrative departments**

The Contracting Parties to the Agreement applying this Regulation shall communicate to the United Nations Secretariat the names and addresses of the technical services responsible for conducting approval tests and of the administrative departments which grant approval and to which forms certifying approval or extension or refusal or withdrawal of approval or production definitely discontinued, issued in other countries, are to be sent.

Explanatory figure  
(see paragraph 2.10.)

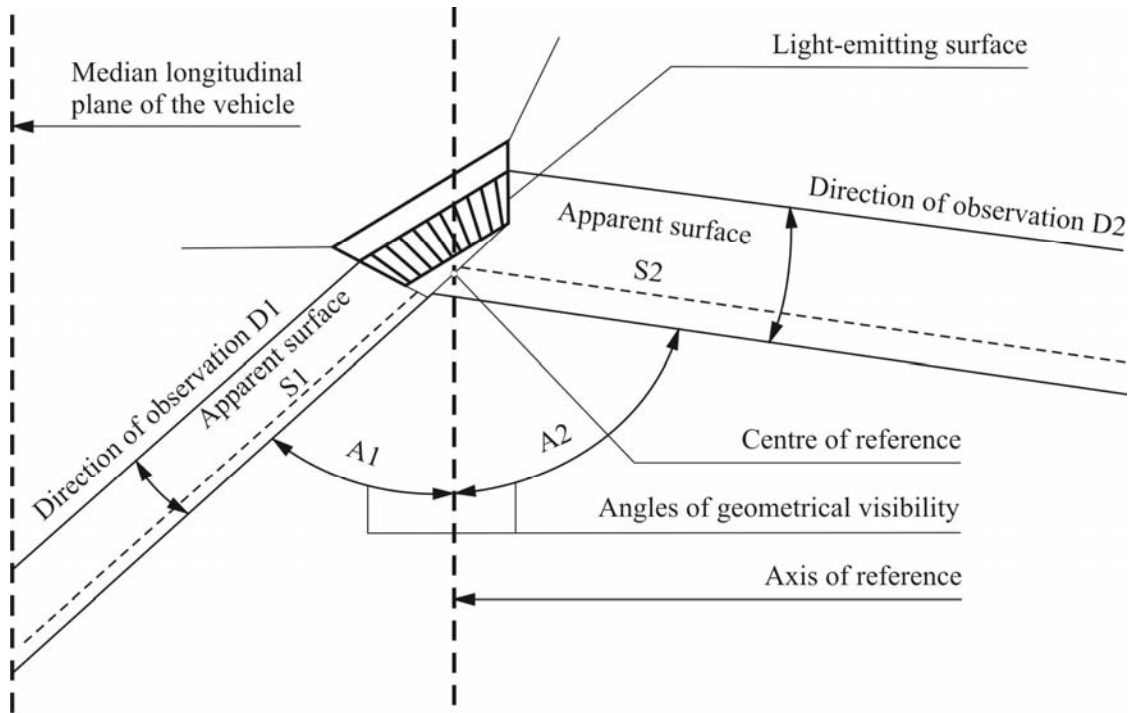

## Annex 1

### Communication

(Maximum format: A4 (210 x 297))



issued by: Name of Administration:

.....  
 .....  
 .....

concerning<sup>2</sup>: APPROVAL GRANTED  
 APPROVAL EXTENDED  
 APPROVAL REFUSED  
 APPROVAL WITHDRAWN  
 PRODUCTION DEFINITELY DISCONTINUED

of a type of agricultural or forestry ~~vehicle tractor~~ with regard to the installation of lighting and light-signalling devices pursuant to Regulation No. 86.

Approval No. .... Extension No. ....

1. Make (trade name) .....
2. Vehicle ~~Tractor~~ type and commercial description classification .....
3. Manufacturer's name and address .....
- .....
4. If applicable, name and address of manufacturer's representative .....
5. Lighting equipment installed on the ~~vehicle tractor~~ submitted for approval<sup>1, 2</sup> .....
- 5.1. **Main-beam headlamps** ~~driving lamps~~: yes/no<sup>3</sup>
- 5.2. **Dipped-beam headlamps** ~~Passing lamps~~: yes/no<sup>3</sup>
- 5.3. Front fog-lamps: yes/no<sup>3</sup>
- 5.4. Reversing lamps: yes/no<sup>3</sup>
- 5.5.1. Front direction-indicator lamps: yes/no<sup>3</sup>
- 5.5.2. Rear direction-indicator lamps: yes/no<sup>3</sup>
- 5.5.3. Repeating side indicator lamps: yes/no<sup>3</sup>
- 5.6. Hazard-warning signal: yes/no<sup>3</sup>

<sup>1</sup> Distinguishing number of the country which has granted/extended/refused/withdrawn approval (see approval provisions in the Regulation).

<sup>2</sup> Show for each device, on a separate form, the types of devices, duly identified, meeting the installation requirements of this Regulation.

<sup>3</sup> Strike out what does not apply.

- 5.7. Stop lamps: yes/no<sup>3</sup>
- 5.8. Front position (~~side~~) lamps: yes/no<sup>3</sup>
- 5.9. Rear position (~~side~~) lamps: yes/no<sup>3</sup>
- 5.10. Rear fog-lamps: yes/no<sup>3</sup>
- 5.11. Parking lamps: yes/no<sup>3</sup>
- 5.12. End-outline marker lamps: yes/no<sup>3</sup>
- 5.13. Work lamps: yes/no<sup>3</sup>
- 5.14. Rear retro-reflectors: yes/no<sup>3</sup>
- 5.15. Non triangular side retro-reflectors: yes/no<sup>3</sup>
- 5.16. Rear registration-plate lamp: yes/no<sup>3</sup>
- 5.17. **Front retro-reflectors, non triangular: yes/no<sup>3</sup>**
- 5.18. **Side-marker lamps: yes/no<sup>3</sup>**
- 5.19. **Daytime running lamp: yes/no<sup>3</sup>**
- 5.20. **Cornering lamp: yes/no<sup>3</sup>**
- 5.21. **Conspicuity markings: yes/no<sup>3</sup>**
- 5.22. **Emergency stop signal: yes/no<sup>3</sup>**
- 5.23. **Signalling panels: yes/no<sup>3</sup>**
- 5.24. **SMV rear marking plate: yes/no<sup>3</sup>**
- 6. Equivalent lamps: yes/no<sup>3</sup> (see paragraph 2.5.1.) .....
- 7. Maximum technically permissible width of the ~~vehicle~~ **tractor**: .....
- 8. ~~Vehicle~~ **Tractor** submitted for approval on .....
- 9. Technical service responsible for conducting approval tests .....
- .....
- 10. Date of report issued by that service .....
- 11. Number of report issued by that service .....
- 12. Approval with regard to the lighting and light-signalling devices is granted/extended/refused/withdrawn<sup>3</sup>
- 13. Position of approval mark on ~~vehicle~~ **tractor** .....
- .....
- 14. Place .....
- 15. Date .....
- 16. Signature .....
- 17. Remarks .....

## Annex 2

### Examples of arrangements of approval marks

Model A

(See paragraph 4.4. of this Regulation)

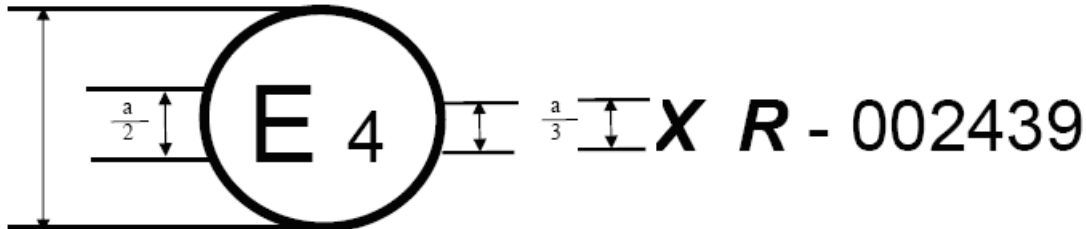

A = 8 mm min.

The above approval mark affixed to an agricultural or forestry ~~vehicle~~ **tractor** shows that the ~~vehicle~~ **tractor** type concerned has, with regard to the installation of lighting and light-signalling devices, been approved in the Netherlands (E 4) pursuant to Regulation No. 86. The approval number indicates that the approval was granted in accordance with the requirements of Regulation No. 86 in its original form.

Model B

(See paragraph 4.5. of this Regulation)

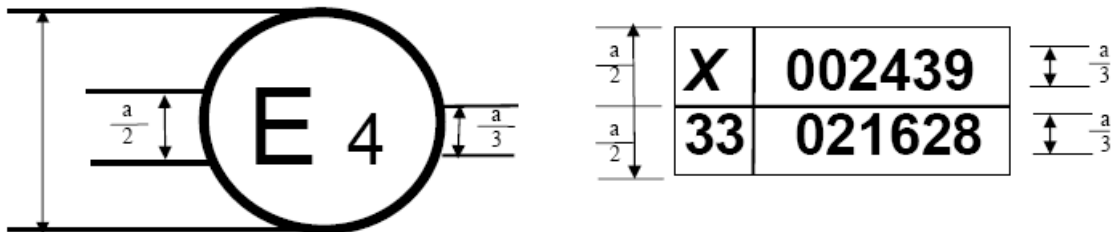

A = 8 mm min.

The above approval mark affixed to an agricultural or forestry vehicle shows that the vehicle type concerned has been approved in the Netherlands (E 4) pursuant to Regulations Nos. 86 and 33\*. The approval numbers indicate that, at the dates when the respective approvals were given, Regulation No. 86 was in its original form and Regulation No. 33 already included the 02 series of amendments.

\* The latter number is given merely as an example.



### Annex 3

#### Definition of the terms of paragraphs 2.6. to 2.10. of this Regulation

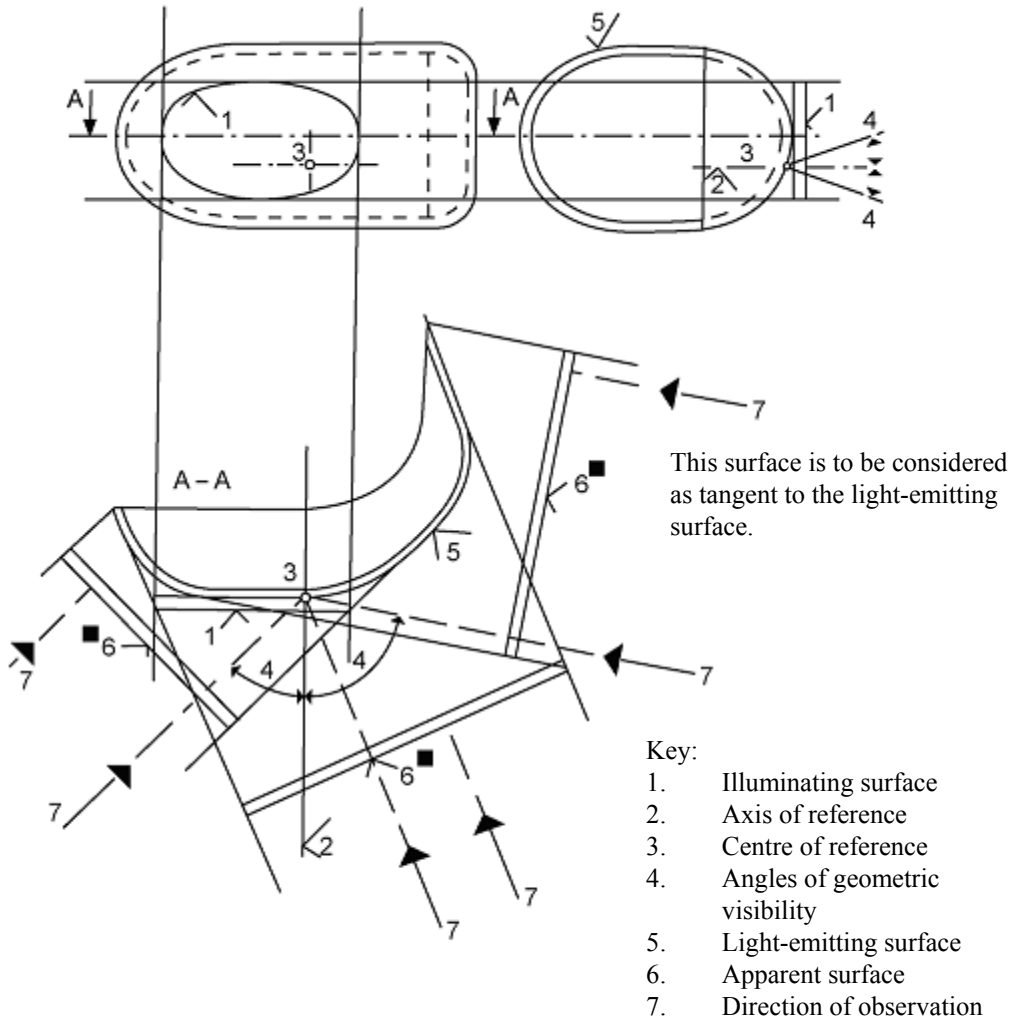

## Annex 4

### Visibility of lamps

(See paragraph 5.10. of this Regulation)

Figure 1

#### Visibility of a red lamp to the front

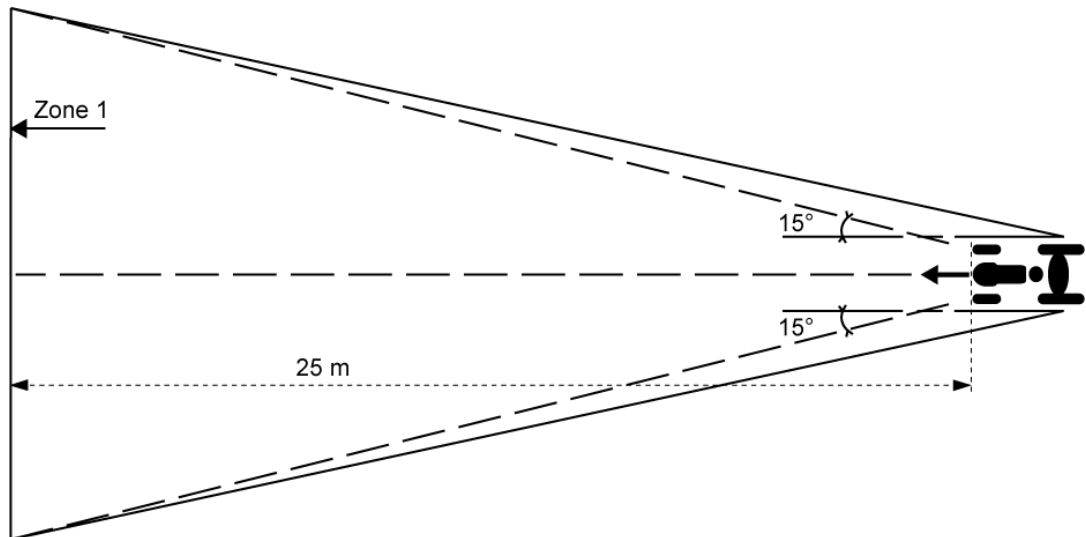
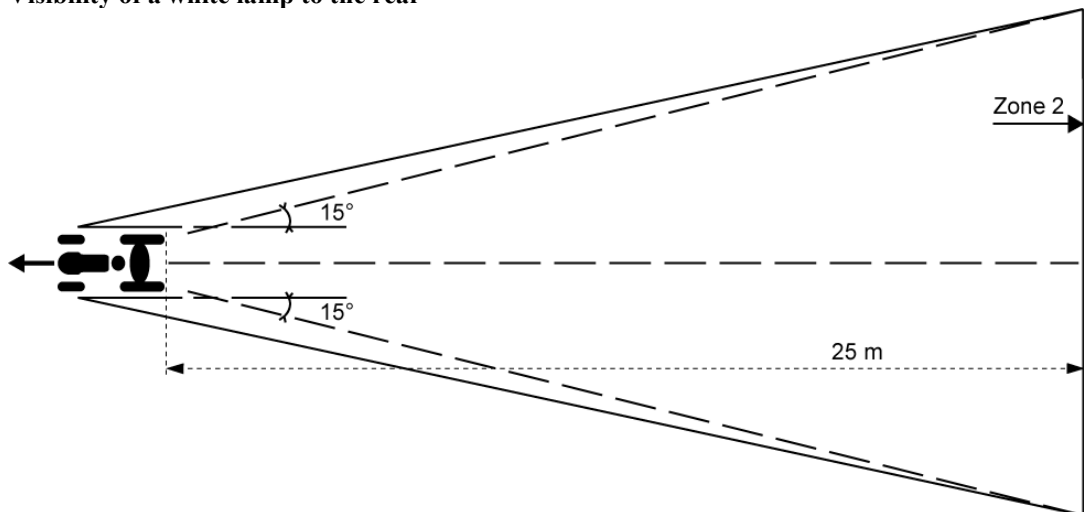

Figure 2

#### Visibility of a white lamp to the rear



**Annex 5 ((to be amended editorially according to 6.5.1, i.e add 1a or 1b after 1, replace 2 by 2b in the figures))**

**Direction-indicator lamps**

Geometric visibility (see paragraph 6.5.4.)

Arrangement A

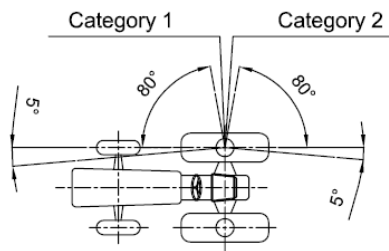

Arrangement B

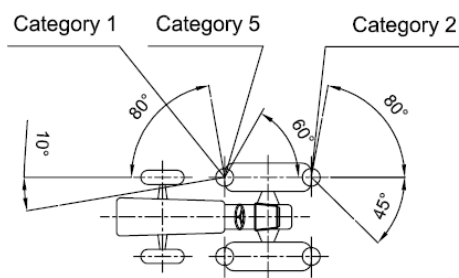

Arrangement C

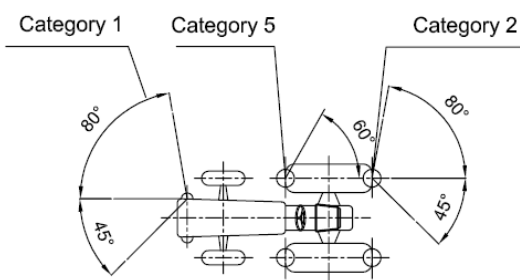

Arrangement D

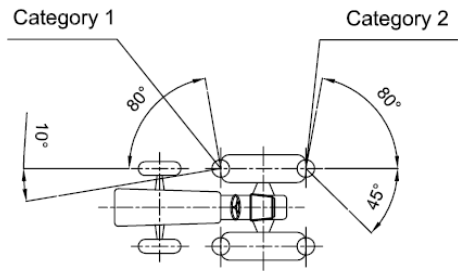

**The value 10° given for the inward angle of visibility of the front indicator may be reduced to 3° for vehicles with an overall width not exceeding 1400 mm.**

---

## Annex 6

### Signalling panels

#### 1. Scope

This annex applies to signalling panels and –foils which are used for the marking of agricultural vehicles to the front and to the side(s).

It describes the dimensions, a minimum size of the reflecting surface, the color and photometric minimum requirements as well as the identification and marking.

The requirements concerning the arrangement and the position of the foils and panels on the agricultural vehicles are determined in paragraph 6.23 of this Regulation.

#### 2. Dimensions, number and minimum reflecting surface

Warning panels and –foils shall have the following dimensions:

Figure 1  
Warning panel resp. –foil

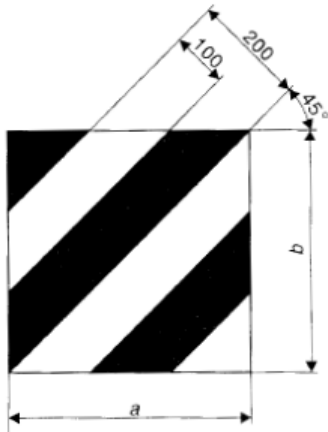

Figure 2  
"Basic square"

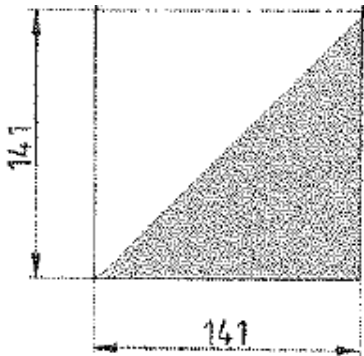

Table 1  
Dimensions [mm]

Warning panel/-foil	a [mm]	b [mm]	Surface [cm <sup>2</sup> ]
Form A	423	423	1790
Form B	282	282	795
Form R1	282	423	1193
Form R2	423	282	
Form L1	141	846	1193
Form L2	846	141	
Form K1	141	423	596
Form K2	423	141	

Deviations from the specified formats are permitted, if the surface of the unspecified formats contains at least 3 "basic squares" The number of panels/foils for each effective direction to the front and the rear are specified in Table 2.

Table 2  
Number of panels/foils for each effective direction

Warning panel/-foil	Number for each effective direction
Form A	2
Form B	2
Form R1	2
Form R2	
Form L1	2
Form L2	
Form K1	4
Form K2	

**Warning boards of Form A may be combined with lamps, if the surface of the boards covered by the lamps does not exceed 150 cm<sup>2</sup>.**

**3. Coloring and photometric minimum requirements**

**White according to 2.29.1 of Regulation No. 48.**

**Red according to 2.29.4 of Regulation No. 48.**

**The photometric requirements of Annex 7 of Regulation No. 69 or of Regulation No. 104 apply.**

**Panels/foils of Form B must comply with Annex 7 of Regulation No. 104, Class C.**

**4. Identification**

**Signalling Panels which comply with the requirements of this regulation are marked with the title of this regulation and the name of the manufacturer.**

## Annex 7

### **Lighting and signalling devices for external projections of vehicles (see paragraph 5.17)**

Vehicles and mounted machines with external projections which cannot practically be protected.

Warning panel to the front and the rear mandatory.

Any rear part of a vehicle exceeding 1.0 m from the illuminating surface of the rear position lamp shall be signalled additionally towards the rear. Signalling devices shall be affixed as close as possible to the rear external limit of that part of the vehicle.

- rear position lamp mandatory

- rear reflector or warning panel

Any front part of a vehicle part exceeding 1.0 m from the illuminating surface of the front position lamp shall be signalled towards the front. Signalling devices shall be affixed as close as possible to the front external limit of the part of the vehicle.

(a) front position lamp mandatory

(b) front reflector or warning panel

To the side with reflectors as specified in 6.15, but up to 4000 mm height.

## **II. Justification ((to be reviewed by AVLI later on))**

1. UN Regulation No. 86 contains Uniform provisions concerning the approval of agricultural or forestry tractors with regard to the installation of lighting and light-signalling devices.

2. The forthcoming revision of the European Union (EU) -type-Approval provisions for agricultural vehicles recommend where possible to replace existing EU Directives by ECE Regulations or at least refer to them in the appropriate Delegated Acts. EU Type Approval will apply in future also to agricultural trailers and towed machines (R and S vehicles in the legal context of EU).

3. A CEMA project team and a Committee of German experts from Industry, Technical Services and other organizations have developed proposals to amend the existing UN Regulation No. 86 considering the following:

- (a) generally an improvement of the conspicuity of agricultural vehicles is desired,
- (b) the scope of UN Regulation No. 86 should be extended to all agricultural vehicles, i. e. all tractors (wheeled and track-laying) and their trailers and towed implements, self-propelled agricultural machines and their trailers and towed implements independent of their maximum design speed;
- (c) especially the lateral signalling and conspicuity should be improved, as a research study of the accident research department of the German Insurance Association (see enclosed summary) showed that a considerable number of accidents can be addressed by such measures;



- (d) manufacturers desire to permit "innovative" lamps (e.g. daytime running lamps, cornering lamps etc.) initially as an option in order to collect experiences,
4. The following proposal for an amendment of UN Regulation No. 86 contains:
- (a) alignment of the present UN Regulation No. 86 with the provisions of the currently applicable EU-Directive 2009/61/EC concerning the installation of lighting and light-signalling devices of agricultural or forestry tractors;
  - (b) installation of "innovative" lamps (e. g. daytime running lamps, cornering lamps etc.) permitted as an option;
  - (c) signalling with warning boards and SMV-Emblem (UN Regulation No. 69) included;
  - (d) where appropriate, the requirements for the lamps added were aligned with the corresponding requirements of UN Regulation No. 48. In detail the following lamps were added:
    - (a) additional stop lamps optional;
    - (b) side reflectors mandatory (~ UN Regulation No. 48);
    - (c) front retro-reflectors (~ UN Regulation No. 48);
    - (d) side marker lamps optional;
    - (e) daytime running lamps optional;
    - (f) cornering lamps optional;
    - (g) conspicuity markings optional;
    - (h) emergency stop signal optional;
    - (i) warning boards for extra-wide vehicles;
    - (k) lane keeping lamps optional (Lamp according to UN Regulation No. 7 to be used for this);
    - (l) courtesy lamps optional;
    - (m) signalling of external projections of vehicles (Annex 7).
-