

Regulation No. XXX

UNIFORM PROVISIONS CONCERNING THE APPROVAL OF I EMERGENCY CALL DEVICES (AECD) II VEHICLES WITH REGARD TO THE INSTALLATION OF AN AECD OF AN APPROVED TYPE III VEHICLES WITH REGARD TO THEIR AECS

Contents

Preliminary comments from the Secretary of GRSG informal group on AECS

1. This document was produced by the informal group Secretary as a **working document**, for serving as a basis for discussions within the GRSG informal group on AECS. It is expected to evolve and improve along the discussions that will take place during the meetings of the informal group.
- ~~2.~~ This document shows the proposal from RUS per document AECS-01-05 (first column from the left) ~~together with the updated;~~ proposal from OICA (justifications to the OICA proposals can be found at the bottom of the document), in conformity with the decision of the 1st meeting of the informal group updated at the 2nd informal group meeting (~~see document AECS-01-07-Rev.1, paragraph 4.1.~~ second column) and the updated proposal from RUS in conformity with the conclusions of the 2nd meeting of informal group under the Draft Report AECS 02-03-Rev1 (third column). When there is divergence between the proposals, all proposals are showed in a table. ~~—RUS in the left column, OICA in the right column.~~
- ~~3.~~ ~~Justifications to the OICA proposals can be found at the bottom of the document (the last two pages). The Secretariat did not have access to the justifications for the RUS proposals.~~
4. All **annexes** providing detailed technical requirements (i.e. annexes 6 to ~~12~~ 14) are put **between** [] because there is at this stage no consensus within the informal group about their presence nor their content yet both deserve in-depth consideration.
5. The document is developed following the decision of the 1st meeting of the informal group for a **3-part structure** (see document AECS-01-07-Rev.1, paragraph 5.), i.e. approval of AECD, approval of a vehicle with regard to the installation of an approved AECD and approval of a vehicle type with regard to AECS.

1. Scope

This Regulation applies to:

- (a) Part I: the AECDs which are intended to be fitted to vehicles of categories M1 and N1¹;
- (b) Part II: the installation on vehicles of categories M1 and N1 of AECDs which have been approved to Part I of this regulation.
- (c) [Part III: vehicles of categories M1 not exceeding 2,5 tons, and N1 where the "R" point of the lowest seat is not more than 700 mm from ground level, with regard to AECS or equipped with an AECD which has not been separately approved according to Part I of this Regulation. Other vehicles may be approved at the request of the vehicle manufacturer.]

Part I: EMERGENCY CALL DEVICES (AECD)

2. Definitions

For the purposes of this Regulation:

	RUS per AECS-01-05	OICA proposal	RUS proposal
2.1	<p>“<i>Emergency call device</i>” (“<i>e-call device</i>”) means a device that determines the location, speed and direction of travel of a vehicle using signals from at least two existing global satellite navigation systems, transmits information on the vehicle if it suffers a road accident or other accident and provides two-way voice communication with the emergency services on mobile telephone communications networks;</p>	<p>“<i>AECD (Accident Emergency Call Device)</i>” means a device that at least :</p> <p>generates a communication toward emergency services if a vehicle suffers a serious road accident and provides two-way voice communication on existing mobile telephone communication networks; and</p> <p>has the ability to provide the vehicle location using signals from an existing global satellite navigation system(s).</p>	<p>“<i>AECD (Accident Emergency Call Device)</i>” means a device that at least :</p> <p>generates a communication toward emergency services if a vehicle suffers a serious road accident and provides two-way voice communication on existing mobile telephone communication networks; and</p> <p>has the ability to provide the vehicle location using signals from global satellite navigation systems.</p>

¹ As defined in Section 2 of the Consolidated Resolution on the Construction of Vehicles (R.E.3) (document TRANS/WP.29/78/Rev.2) – www.unece.org/trans/main/wp29/wp29wgs/wp29gen/wp29_resolutions.html.

2.2	<p>“Core component of an e-call device” means a component that provides the functions of the e-call device listed in paragraph 2.1 above. The core components of an e-call device are:</p> <ul style="list-style-type: none"> (a) a navigation system receiver; (b) a global navigation satellite system receiver antenna; (c) a communications module; (d) a communications module antenna; (e) an in-band modem; (f) a user interface unit; (g) a control module; (h) a backup power supply (optional). 		<p>“Core component of an e-call device AECD” means a component that provides the functions of an e-call device AECD listed in paragraph 2.1 above. The core components of an e-call device AECD device are:</p> <ul style="list-style-type: none"> (a) a global navigation satellite system receiver (GNSS receiver); (b) a global navigation satellite system receiver antenna (GNSS antenna); (c) a communications module; (d) a communications module antenna; (e) an in-band modem; (f) a user interface unit; (g) a control module; (h) a backup power supply (optional).
-----	---	--	---

2.3	<p>“Road accident” means an event that occurs during the movement, and with the participation, of a vehicle on a road, in which people are killed or injured, vehicles, equipment or goods are damaged, or any other material damage is caused;</p>		<p>“Road accident” means an event that occurs during the movement, and with the participation, of a vehicle on a road, in which people are killed or injured, vehicles, equipment or goods are damaged, or any other material damage is caused;</p>
-----	---	--	---

2.4	<p>“Navigation system receiver” means a component of an e-call device designed to determine the current coordinates, motion parameters (direction and speed) of the vehicle, and time using signals from global navigation satellite systems;</p>	<p>“Global Positioning System receiver” means a component of an AECD designed to determine time, the coordinates and direction of the vehicle using signals from global navigation satellite systems;</p>	<p>“Global Positioning Navigation Satellite System receiver” (“GNSS receiver”) means a component of an AECD designed to determine time, the coordinates and direction of the vehicle using signals from global navigation satellite systems;</p>
-----	---	---	---

2.5	“Communications module” means a component of an e-call device designed to transmit information about an accident using mobile telephone communications networks;	“ <i>Communications module</i> ” means a component of an AECD designed for voice communication and to transmit data about an accident using terrestrial mobile telephone communications networks;	“ <i>Communications module</i> ” means a component of an AECD designed for voice communication and to transmit data about an accident using terrestrial mobile telephone communications networks;
-----	--	---	---

2.6	“ <i>Voice modem</i> ” means a component of an e-call device designed for voice communications on mobile telephone communications networks;		
-----	---	--	--

2.7	“ <i>User interface unit</i> ” means a component of an e-call device designed to allow the user to interact with the device, including by receiving visual information, obtaining visual information and introducing control commands;	“ <i>User interface</i> ” means a component or function of an AECD designed to allow the user to interact with the device, including by receiving visual information, obtaining visual information and introducing control commands;	“ <i>User interface</i> ” means a component or function of an AECD designed to allow the user to interact with the device, including by receiving visual information, obtaining visual information and introducing control commands;
-----	--	--	--

2.8 “*Control module*” means a component of an AECD designed to ensure the combined functioning of all components of the ~~e-call device~~ AECD;

2.9	“ <i>Type of e-call device</i> ” means devices that do not differ in their construction, including the manner of attachment to the bodywork;	“ <i>Type of e-call device</i> ” means devices that do not differ in such essential respects as: (a) The manufacturer's trade name or mark; (b) their construction;	“ <i>Type of e-call device AECD</i> ” means devices that do not differ in such essential respects as: (c) The manufacturer's trade name or mark; (d) their construction; (e) dimensions, structure and materials of the attachments and supports [inspired by Reg.80 clause 2.3.3].
-----	--	---	--

2.10. “*Vehicle type with regard to its AECS*” means a category of vehicles which do not differ in such essential respects as:

- (a) The manufacturer's trade name or mark;
- (b) Vehicle features which significantly influence the performances of the AECS;
- (c) The type and design of the AECS;

2.11.	<p>“Data exchange protocol” means the set of rules and agreements that define the content, format, time parameters, sequence and error checks in messages exchanged between an e-call device and the devices of the ground response infrastructure.</p>	<p>“Data exchange protocol” means the set of rules and agreements that define the content, format, time parameters, sequence and error checks in messages exchanged between an AECD and the devices of Public Service Answering Party (PSAP).</p>	<p>“Data exchange protocol” means the set of rules and agreements that define the content, format, time parameters, sequence and error checks in messages exchanged between an AECD and the devices and/or information systems used for data transfer to / from of Public Service Safety Answering Party Point (PSAP) and emergency response services.</p>
2.12.		<p>“Public/Private Safety Answering Point (PSAP)” means a call center responsible for answering calls to an emergency telephone call. It can be of two types</p> <ul style="list-style-type: none"> – Public Safety Answering Point managed by the public services of a Contracting Party to the 58 Agreement; – Private Safety Answering Point managed by a private company. 	<p>“Public/Private Safety Answering Point (PSAP)” means a physical location where emergency calls are first received under the responsibility of a public authority or a private organisation recognised by the national government, working on behalf of the responsible authorities [inspired by CEN 16062 & 16072] call center responsible for answering calls to an emergency telephone call. It can be of two types</p> <ul style="list-style-type: none"> – Public Safety Answering Point managed by the public services of a Contracting Party to the 58 Agreement; – Private Safety Answering Point managed by a private company.

3. Application for approval of an AECD

- 3.1 The application for approval of a type of AECD shall be submitted by the holder of the trade name or mark or by his duly accredited representative.
- 3.2 A model of the information document is given in Annex 1.
- 3.3 For each type of AECD, the application shall be accompanied by samples of complete sets of AECDs in sufficient quantities for the tests prescribed by this regulation. Additional specimens may be called for at the request of the laboratory.

4. Markings of an AECD

4.1.	The samples of e-call devices submitted for approval shall bear the trade name or mark of the manufacturer. This marking shall figure at least on the unit or units containing the navigation system receiver and communications module, as well as on the front face of the user interface unit. It shall be clearly legible and be indelible.	The samples of e-call devices submitted for approval shall bear the trade name or mark of the manufacturer. This marking shall figure at least on the unit or units containing the navigation system receiver and communications module. It shall be clearly legible and be indelible.	The samples of e-call devices AECD submitted for approval shall bear the trade name or mark of the manufacturer. This marking shall figure at least on the unit or units containing the navigation system receiver and communications module. It shall be clearly legible and be indelible.
4.2.	The unit or units containing the navigation system receiver and communications module, as well as the front face of the user interface unit of each e-call device shall possess a space large enough to accommodate the approval mark, which shall be legible when the device has been mounted on the vehicle. This space shall be shown on the drawings referred to in Annex 1.	The unit or units containing the navigation system receiver and communications module shall possess a space large enough to accommodate the approval mark. This space shall be shown on the drawings referred to in Annex 1.	The unit or units containing the navigation system receiver and communications module shall possess a space large enough to accommodate the approval mark. This space shall be shown on the drawings referred to in Annex 1.

5. Approval

- 5.1 If the samples submitted for approval meet the requirements of paragraph 6 of this Regulation, approval of the pertinent type of AECD shall be granted.
- 5.2 An approval number shall be assigned to each type approved. The first two digits (at present 00) shall indicate the series of amendments incorporating the most recent

major technical amendments made to the Regulation at the time of issue of the approval. The same Contracting Party shall not assign the same number to another type of AECD.

- 5.3 Notice of approval or of refusal, or of extension or withdrawal of approval, or of production definitively discontinued of a type of AECD pursuant to this Regulation shall be communicated to the Parties to the Agreement which apply this Regulation by means of a form conforming to the model in annex 3 to this Regulation.
- 5.4 There shall be affixed, conspicuously and in the space referred to in paragraph 4.2 above, to every AECD conforming to a type approved under this Regulation, in addition to the mark prescribed in paragraph 4.1., an international approval mark conforming to the model given in annex 5, consisting of:
 - 5.4.1 A circle surrounding the letter “E” followed by the distinguishing number of the country which has granted approval;²
 - 5.4.2 The number of this Regulation, followed by the letter “R”, a dash and the approval number to the right of the circle prescribed in paragraph 5.4.1.
- 5.5 The approval mark shall be clearly legible and be indelible.

6. Requirements

6.1	The effectiveness of AECD shall not be adversely affected by magnetic or electrical fields. This requirement shall be met by ensuring compliance with Regulation No. 10:	The effectiveness of AECD shall not be adversely affected by magnetic or electrical fields. This requirement shall be met by ensuring compliance with Regulation No. 10:	The effectiveness of AECD shall not be adversely affected by magnetic or electrical fields. This requirement shall be met by ensuring compliance with Regulation No. 10:
	(a) 03 series of amendments for vehicles that do not have a rechargeable energy storage system (traction battery) that can be charged from an external source;	[6.1.1. AECD shall be designed, constructed and installed in such a way that the vehicle when equipped shall continue to comply with the relevant technical requirements, especially with regard to electromagnetic	[6.1.1. AECD shall be designed, constructed and installed in such a way that the vehicle when equipped shall continue to comply with the relevant technical requirements, especially with regard to electromagnetic compatibility (EMC).]

² The distinguishing numbers of the Contracting Parties to the 1958 Agreement are reproduced in annex 3 to the Consolidated Resolution on the Construction of Vehicles (R.E.3), document ECE/TRANS/WP.29/78/Rev.2/Amend.3 –www.unece.org/trans/main/wp29/wp29wgs/wp29gen/wp29resolutions.html.

		compatibility (EMC).]	
	(b) 04 series of amendments for vehicles fitted with a rechargeable energy storage system (traction battery) that can be charged from an external source.	[6.1.2. Vehicles which are equipped with AECD shall comply with the relevant technical requirements, especially with regard to electromagnetic compatibility (EMC).]	[6.1.2. Vehicles which are equipped with AECD shall comply with the relevant technical requirements, especially with regard to electromagnetic compatibility (EMC).]
		6.1.3. The effectiveness of AECD shall not be adversely affected by magnetic or electrical fields REFERENCE TO ISO-7637 SECTION XXX	AECD shall be tested for radiated and conducted emissions, for immunity to radiated and conducted disturbances. <i>[inspired by Reg.10 clause 6.1.1.2].</i>
6.1.3.1			AECD shall be tested for immunity to electromagnetic radiation. AECD immunity type approval limits and conformance test methods in accordance with Regulation No. 10 (clause 6.7 and Annex 9).
6.1.3.2			Narrowband type approval limits concerning narrowband electromagnetic interference generated by AECD and conformance test methods in accordance with Regulation No. 10 (clause 6.6 and Annex 9).
6.1.3.3			Immunity of AECD against disturbances conducted along supply lines Apply test pulses 1, 2a/2b, 3a, 3b, 4 and 5a/5b according to the International Standard ISO 7637-2:2004 to the supply lines as well as to other connections of AECD which may be operationally connected to supply lines. Concerning pulse 5, pulse 5b shall be applied on vehicles which include an

			<p>alternator with internal limitation diode and pulse 5a shall be applied for others cases.</p> <p>Concerning the pulse 2, pulse 2a shall always be applied and pulse 2b could be performed with the agreement between the vehicle manufacturer and the technical approval services.</p> <p>AECD in unset state and set state</p> <p>The test pulses 1 through 5 shall be applied. The required functional status for all applied test pulses are given in table 1.</p> <p>T a b l e 1 – Severity/functional status (for supply lines)</p> <table border="1" data-bbox="1102 943 1501 1335"> <thead> <tr> <th><i>Test pulse number</i></th> <th><i>Test level</i></th> <th><i>Functional status</i></th> </tr> </thead> <tbody> <tr> <td>1</td> <td>III</td> <td>C</td> </tr> <tr> <td>2a</td> <td>III</td> <td>B</td> </tr> <tr> <td>2b</td> <td>III</td> <td>C</td> </tr> <tr> <td>3a</td> <td>III</td> <td>A</td> </tr> <tr> <td>3b</td> <td>III</td> <td>A</td> </tr> <tr> <td>4</td> <td>III</td> <td>B</td> </tr> <tr> <td>5a/5b</td> <td>III</td> <td>A</td> </tr> </tbody> </table>	<i>Test pulse number</i>	<i>Test level</i>	<i>Functional status</i>	1	III	C	2a	III	B	2b	III	C	3a	III	A	3b	III	A	4	III	B	5a/5b	III	A
<i>Test pulse number</i>	<i>Test level</i>	<i>Functional status</i>																									
1	III	C																									
2a	III	B																									
2b	III	C																									
3a	III	A																									
3b	III	A																									
4	III	B																									
5a/5b	III	A																									
6.1.3.4			<p>Specifications concerning the emission of transient conducted disturbances generated by AECD on supply lines and conformance test methods in accordance with Regulation No. 10 (clause 6.9).</p>																								

6.1.3.5			<p>Immunity of AECD against disturbance coupled on signal lines.</p> <p>Leads which are not connected to supply lines (e.g. special signal lines) shall be tested in accordance with the International Standard ISO7637-2:2004. The required functional status for all applied test pulses are given in table 2.</p> <p>T a b l e 2 – Test level / functional status (for signal lines)</p> <table border="1" data-bbox="1098 734 1481 869"> <thead> <tr> <th>Test pulse number</th> <th>Test level</th> <th>Functional status</th> </tr> </thead> <tbody> <tr> <td>3a</td> <td>III</td> <td>C</td> </tr> <tr> <td>3b</td> <td>III</td> <td>A</td> </tr> </tbody> </table>	Test pulse number	Test level	Functional status	3a	III	C	3b	III	A
Test pulse number	Test level	Functional status										
3a	III	C										
3b	III	A										
6.1.3.6			<p>Tests concerning the immunity of AECD to electric interference created by electrostatic discharge are set up according to test methods described in ISO/TR 10605-1993 or EN 61000-4-2.</p>									
6.1.3.7			<p>AECD shall comply with requirements EN 301 489-1 V1.8.1 (2008-04), EN 301 489-7 V1.3.1 (2005-11) and EN 301 489-24 V1.4.1 (2007-09) concerning communication on mobile telephone communication networks.</p>									

6.2	<p>The AECD shall be climate resistant. This requirement shall be deemed to be met if the AECD has withstood all tests prescribed in annex 6.</p>	<p>The AECD shall be climate resistant. This requirement shall be demonstrated by compliance with the performance requirements of Annex 6 / REFERENCE / copy/paste of paragraph 6.4. of R116</p>	<p>The AECD shall be climate resistant.</p> <p>All components of the AECD shall operate without any failure under the following conditions. [<i>Inspired by Reg. 116 clause 6.4.</i>]</p>
-----	---	--	---

6.2.1			<p>Climatic conditions</p> <p>Two classes of environmental temperature are defined as follows:</p> <p>(a) -40°C to +85°C for parts to be fitted in the passenger or luggage compartment,</p> <p>(b) -40°C to +125°C for parts to be fitted in the engine compartment unless otherwise specified.</p>
6.2.2			<p>Degree of protection for installation:</p> <p>The following degrees of protection in accordance with IEC Publication 529-1989 shall be provided:</p> <p>(a) IP 40 for parts to be fitted in the passenger compartment,</p> <p>(b) IP 42 for parts to be fitted in the passenger compartment of roadsters/convertibles and cars with moveable roof-panels if the installation location requires a higher degree of protection than IP 40,</p> <p>(c) IP 54 for all other parts.</p> <p>The AECD manufacturer shall specify in the installation instructions any restrictions on the positioning of any part of the installation with respect to dust, water and temperature.</p>
6.2.3.			<p>Weatherability:</p> <p>7 days according to IEC 68-2-30-1980.</p>
6.2.4			<p>Requirement 6.2.1 – 6.2.3 shall be demonstrated with test methods described in Annex 6.</p>

6.3.	The AECD shall be resistant to mechanical impact. This requirement shall be deemed to be met if the AECD has withstood all tests prescribed in annex 7.	The AECD shall be resistant to mechanical impact. This requirement shall be demonstrated by compliance with the performance requirements of Annex 7 / REFERENCE / copy/paste of paragraph XX of Standard YYY	The AECD shall be resistant to mechanical impact. All components of the AECD shall operate without any failure under the following conditions.
6.3.1			<p>Vibration conditions:</p> <p>The AECD components are subdivided into two types:</p> <p>Type 1: components normally mounted on the vehicle, Type 2: components intended for attachment to the engine.</p> <p>The components/AECD shall remain operational under a sinusoidal vibration mode characterised as follows:</p> <p>For type 1 The frequency shall be variable from 10 Hz to 500 Hz with a maximum amplitude of " 5 mm and maximum acceleration of 3 g (0-peak).</p> <p>For type 2 The frequency shall be variable from 20 Hz to 300 Hz with a maximum amplitude of " 12 mm and maximum acceleration of 15 g (0-peak).</p> <p>For both type 1 and type 2 The frequency variation is 1 octave/min. The number of cycle is 10, the test shall be performed along each of the 3 axes. The vibrations are applied at low frequencies at a maximum constant amplitude and at a maximum</p>

			constant acceleration at high frequencies.
6.3.2			Shock conditions: AECD should remain operational during and after repeated shocks in each of three mutually perpendicular positions with the following values of influencing factors: - peak shock acceleration – 98 m/s ² (10 g); - shock repetition frequency – no more than 80 shocks/min; - shock duration – from 5 to 15 ms (preferably – 10 ms); - the number of shocks in each direction – 3333 (overall number of shocks – 10000).
6.3.3			Requirements 6.3.1 - 6.3.2 shall be demonstrated with test methods described in Annex 7.
6.4.	The AECD shall remain operational after the dynamic testing in accordance with the appendix to annex 9 of Regulation No. 17. Details of the test procedure are given in annex 8.	The AECD shall remain operational after frontal impact. This shall be demonstrated by compliance with the performance requirements of Annex 8 REFERENCE / copy/paste of Annex 9 to R17	The AECD shall remain operational after frontal impact. This shall be demonstrated by withstanding the test pulse described in annex 9 - appendix of Regulation No. 17.
6.5	The AECD shall ensure reception and processing of standard precision navigation signals. This requirement is deemed to be met if the AECD has withstood all tests prescribed in annex 9.	The AECD shall be capable of proper reception and processing of standard precision global positioning signals. This shall be deemed to be fulfilled if the Global Navigation Signal System Receiver is compliant with CEP95.	The AECD shall be capable of proper reception and processing of standard precision GNSS signals. The AECD GNSS receiver shall comply with requirements 6.5.1 – 6.5.7

6.5.1			The GNSS receiver shall receive and process the signals from at least two global satellite navigation systems.
6.5.2			The GNSS receiver shall operate and provide navigation solution with accuracy of 15 m at confidence factor 0,95 in horizontal plane at speed up to 250 km/h.
6.5.3			The observation interval shall not exceed 1 sec. GNSS data output rate shall be configurable.
6.5.4			Re-acquisition time after block out of 60 sec shall not exceed 5 sec.
6.5.5			Time to first fix after ignition start shall not exceed 60 sec.
6.5.6			Sensitivity at receiver input shall be acquisition: at least minus 163 Dbw tracking: at least minus 188 Dbw

6.5.7

The navigation receiver shall comply with requirements 6.5.1-6.5.6 while operating at signal level of minus 161 Dbw at the receiver input under influence of harmonic and pulse interference signals described in Tables 1, 2, and 3.

T a b l e 1 – Threshold values of harmonic interference for stability test (GLONASS signals)

Frequency, MHz	Threshold values of interference signals, Dbw
$F < 1540$	Minus 15
$1540 < F \leq 1562$	From minus 15 to minus 50
$1562 < F \leq 1583$	From minus 50 to minus 90
$1583 < F \leq 1593$	From minus 90 to minus 140
$1593 < F \leq 1609$	Minus 140
$1609 < F \leq 1613$	From minus 140 to minus 80
$1613 < F \leq 1626$	From minus 80 to minus 60
$1626 < F \leq 1670$	From minus 60 to minus 15
$F > 1670$	Minus 15

			<p>T a b l e 2 – Threshold values of harmonic interference for stability test (GPS signals)</p> <table border="1"> <thead> <tr> <th>Frequency, MHz</th> <th>Threshold values of interference signals, Dbw</th> </tr> </thead> <tbody> <tr> <td>F < 1525</td> <td>Minus 15</td> </tr> <tr> <td>1525 < F ≤ 1565</td> <td>From minus 50 to minus 140</td> </tr> <tr> <td>1565 < F ≤ 1585</td> <td>Minus 140</td> </tr> <tr> <td>1585 < F ≤ 1610</td> <td>From minus 140 to minus 60</td> </tr> <tr> <td>1610 < F ≤ 1626</td> <td>From minus 60 to minus 50</td> </tr> <tr> <td>1626 < F ≤ 1670</td> <td>From minus 50 to minus 15</td> </tr> <tr> <td>F > 1670</td> <td>Minus 15</td> </tr> </tbody> </table> <p>T a b l e 3 – Inteference pulse parameters for stability test</p> <table border="1"> <thead> <tr> <th>Parameter</th> <th>Value</th> </tr> </thead> <tbody> <tr> <td>Peak power, Dbw</td> <td>Minus 10</td> </tr> <tr> <td>Pulse duration, ms</td> <td>≤1</td> </tr> <tr> <td>Pulse duty cycle</td> <td>≥10</td> </tr> </tbody> </table>	Frequency, MHz	Threshold values of interference signals, Dbw	F < 1525	Minus 15	1525 < F ≤ 1565	From minus 50 to minus 140	1565 < F ≤ 1585	Minus 140	1585 < F ≤ 1610	From minus 140 to minus 60	1610 < F ≤ 1626	From minus 60 to minus 50	1626 < F ≤ 1670	From minus 50 to minus 15	F > 1670	Minus 15	Parameter	Value	Peak power, Dbw	Minus 10	Pulse duration, ms	≤1	Pulse duty cycle	≥10
Frequency, MHz	Threshold values of interference signals, Dbw																										
F < 1525	Minus 15																										
1525 < F ≤ 1565	From minus 50 to minus 140																										
1565 < F ≤ 1585	Minus 140																										
1585 < F ≤ 1610	From minus 140 to minus 60																										
1610 < F ≤ 1626	From minus 60 to minus 50																										
1626 < F ≤ 1670	From minus 50 to minus 15																										
F > 1670	Minus 15																										
Parameter	Value																										
Peak power, Dbw	Minus 10																										
Pulse duration, ms	≤1																										
Pulse duty cycle	≥10																										
6.5.8			<p>Requirements 6.5.1 - 6.5.7 shall be demonstrated with test methods described in Annex 9</p>																								

6.6.	<p>[The AECD shall allow communications on mobile telephone communications networks using GSM-900, GSM-1800, UMTS-900 and UMTS-2000 standards. The implementation of requirements for the communication module is confirmed by compliance with 3GPP TS 51.010-1 standard and following ETSI standards: ETSI TS 126 267, ETSI TS 126 268, ETSI TS 126 269. In addition, the AECD shall comply with the following requirements:</p>	<p>[The AECD shall be capable of communication on mobile telephone communication networks.] [The AECD shall be capable of communication on mobile telephone communication network(s) of the market where the AECD is intended to be put on the market.] [The AECD shall at least be indicated in the national regulation of the Contracting Party where the AECD is submitted for approval] [The Applicant shall provide evidence of compliance of capacity of communication on mobile telephone communication network(s) of the markets where the AECD is intended to be marketed by documentation.] identified in Annex XXX. This shall be demonstrated by compliance with 3GPP TS 51.010-1 standard and following ETSI standards:</p> <ul style="list-style-type: none"> — ETSI TS 126 267 DATE (eCall Data Transfer – General Description); — ETSI TS 126 268 DATE (eCall Data Transfer – Conformance testing); — ETSI TS 126 269 DATE (eCall Data Transfer – Characterisation Report) <p>In addition, the AECD shall comply with the following requirements:</p>	<p>The AECD shall be capable of communication on mobile telephone communication networks using the following standards:</p> <ul style="list-style-type: none"> - for vehicles intended to be marketed in EU: TBD - for vehicles intended to be marketed in Russia: GSM-900, GSM-1800, UMTS-900 and UMTS-2000 - for vehicles intended to be marketed in Japan: TBD <p>The implementation of requirements for the communication module is confirmed by compliance with the following specifications:</p> <ul style="list-style-type: none"> - for EU: TBD - for Russia: 3GPP TS 51.010-1, ETSI TS 126 267, ETSI TS 126 268, ETSI TS 126 269, ETSI TS 124 008, 3GPP TS 34.121-1, 3GPP TS 34.122 - for Japan: TBD
------	---	---	---

6.6.1 The AECD shall comply with the following rules of registration in the network serving emergency calls.

- 6.6.1.1 If the AECD is used only for emergency call service, then it shall comply with the requirements for the “eCall only mobile station” as defined in section 10.7 of ETSI TS 122 101. The AECD shall stay in the “eCall only mobile station” mode whenever ignition is turned on.
- 6.6.1.2 If the AECD is used only for emergency call service and additional commercial services, and the requirements of additional commercial services do not prescribe that AECD is registered in the network, than AECD shall follow the requirements of section 6.6.0.1.
- 6.6.1.3 Regardless the network registration status before emergency call request, upon reception of an emergency call request the AECD shall immediately register in the network serving emergency calls.
- 6.6.1.4 Total time elapsed from the emergency call request until emergency call setup shall not exceed 20 sec.
- 6.6.1.5 Upon completion of emergency call the AECD shall stay registered in the network serving emergency calls for 2 hours or until reception of deregistration commands, whatever happens earlier.

6.6.2	The AECD shall be fitted with a non-removable personal multiprofile universal SIM card that functions on mobile telephone networks using the above-mentioned standards. It shall have the capacity to update information that is stored on the non-removable personal multiprofile universal SIM card on mobile telephone networks using the above-mentioned standards; [Other requirements to be regulated nationally]	The AECD shall be fitted with a non-removable personal SIM that functions on mobile telephone networks using the standards mentioned in Annex XXX1. It shall have the capacity to upload update information that is stored on the non-removable personal SIM on mobile telephone networks, using the standards mentioned in Annex XXX1. [Other requirements to be regulated nationally]	The AECD shall be fitted with a non-removable SIM that functions on mobile telephone networks using the standards mentioned in section 6.6. Additional requirements to be regulated nationally.
-------	---	--	---

6.6.3	The communications module shall provide batch transmission of data on the accident. The data exchange protocol shall establish mandatory priority flagging for emergency calls. The specifications for data exchange protocols are given in annex 10.	[The communications module shall provide batch transmission of data on the accident. The data exchange protocol shall establish mandatory priority flagging for emergency calls. The specifications for data exchange protocols are given in annex 10.]	<p>When setting up an emergency call, the AECD shall set bits 6 and 7 of the service category element in accordance with ETSI TS 124 008.</p> <p>The AECD shall enable the following mechanisms of data transmission:</p> <ul style="list-style-type: none"> - for EU: in-band data transmission in accordance with ETSI TS 126 267; - for Russia: in-band data transmission in accordance with ETSI TS 126 267; SMS in accordance with mobile communication standards listed in section 6.6; - for Japan: TBD. <p>The AECD shall be able to generate / respond to the following messages (Table 4):</p>
-------	---	---	---

Table 4. Requirements for data exchange

Data and commands	Transmitting side	Receiving side	Data transmission mechanism	Notes
MSD	AECD	PSAP	In-band modem	Applicable for EU and Russia [Japan?]. MSD format is described in Annex 14
MSD	AECD	PSAP	SMS	Applicable for Russia [Japan?]. The AECD shall send MSD via SMS in case in-band MSD transmission failed. The AECD shall also send MSD via SMS upon reception of the corresponding command.
Command to re-send MSD via SMS	PSAP	AECD	SMS	Applicable for Russia [Japan?]. The specifications for data exchange protocols are given in Annex 10.
Command to place an emergency call	PSAP	AECD	SMS	

Command to deregister from the network serving emergency calls	PSAP	AECD	SMS	
MSD containing AECD testing results	AECD	PSAP	In-band modem	Applicable for Russia [Japan?]. MSD format is described in Annex 14

6.6.4	The communications module shall provide a full duplex voice connection in speakerphone mode, with an emergency services operator, the transmission of message about the vehicle by means of in-band modem, functioning in mobile wireless communication standards GSM 900 and GSM 1800, UMTS 900 and UMTS 2000.	When fitted, the communications module shall provide full duplex voice connection in speakerphone mode compatible with the PSAP identified in Annex XXX2.	The AECD shall provide full duplex hands-free voice connection with the PSAP using the mobile communication standards listed in section 6.6.
-------	---	---	--

6.6.5	If it is not possible to transmit information using the voice modem for 20 seconds after the start of data transmission, the AECD stops using the voice modem and transmits the information by means of text messages (SMS). There shall be provision for the information to be transmitted a second time using the voice modem, working through the established voice connection, and by means of SMS. If it is not possible to transmit information using mobile telephone networks, the information not transmitted shall be stored in an energy-independent memory and	When fitted with full duplex voice connection capability, the AECD shall stop data transmission via in-band modem not later than [20] seconds after having started the demand, if no duplex voice communication can be established.	The AECD shall stop data transmission via in-band modem not later than [20] seconds after having started the demand, if in-band MSD transmission failed, and enable voice connection with PSAP. For Russia, in addition, the AECD shall immediately send MSD via SMS if in-band MSD transmission failed. If the connection was interrupted before the AECD has successfully completed MSD transmission, while 20 sec since the demand have not elapsed, the AECD shall re-establish the call and initiate MSD retransmission by in-band modem. If the connection was interrupted after
-------	--	---	--

	transmitted when possible.		<p>the AECD has successfully completed MSD transmission, or after the 20 sec since the demand have elapsed, the AECD shall re-establish the telephone connection but shall not initiate the retransmission of MSD by in-band modem.</p> <p>In case it was not possible to establish voice connection and/or send MSD using mobile communication networks listed in section 6.6, the AECD shall store the MSD in non-volatile memory and attempt retransmission when network service is available.</p>
--	----------------------------	--	---

6.6.6 After the emergency call is completed, the following shall be ensured:

6.6.6.1	Reception of command in SMS format concerning the repeat emergency call, and the issue of the repeat emergency call within a configurable period of time;		Processing of commands described in Table 4 (if applicable).
---------	---	--	--

6.6.6.2 Automatic reception of incoming phone calls for a period of not less than 20 minutes after the emergency call.]

6.7	The AECD shall offer the possibility of checking its functionality in automatic and manual modes, and show information on any faults on an optical device status indicator or a message on the instrument panel. It shall also be possible for device test results to be transmitted using mobile telephone communications networks as described in	The AECD shall provide the driver with a failure warning when there is a failure in the AECD that prevents the requirements of this Regulation of being met. The warning shall be as specified in paragraph XXX below.	<p>The AECD shall provide the driver with a failure warning when there is a failure in the AECD that prevents the requirements of this Regulation of being met. The warning shall be as specified in paragraph XXX below.</p> <p>For Russia:</p> <p>The AECD shall transition into test mode upon demand.</p> <p>Upon transition into test mode the AECD shall make a test call and</p>
-----	---	--	--

	paragraph 6.5.		<p>transmit the tests results via in-band modem using MSD format specified in Annex 14.</p> <p>The AECD shall exit test mode upon successful transmission of the test results. The AECD shall also exit test mode if the AECD has been moved with ignition on a distance greater than 300 m from the location where test mode was entered.</p>
--	----------------	--	--

6.8	The AECD shall undergo functional testing in accordance with annex 11.	The AECD shall undergo functional testing in accordance with annex 11.	The AECD shall demonstrate compliance with functional requirements by undergoing functional testing in accordance with Annex 11.
-----	--	--	--

6.9	The AECD shall be able to operate autonomously for a period of not less than 60 minutes in call-back mode and subsequently not less than 10 minutes in voice communication mode through the use of a backup battery when power is not available from the on-board electrical system. The lifetime of a backup battery shall be not less than three years.	The AECD shall be able to operate autonomously for a period of not less than 20 minutes in call-back mode and subsequently not less than 5 minutes in voice communication mode.	If fitted with backup battery, the AECD shall be able to operate autonomously for a period of not less than 60 minutes in call-back waiting mode and subsequently not less than 10 minutes in voice communication mode. The lifetime of a backup battery shall be not less than three years.
-----	---	---	--

6.10	The AECD shall have the capacity to function with additional external devices (including devices that detect the type of accident), connected by means of a standardized connector and a standardized data transfer protocol. The physical interface for data transfer shall offer a data transfer speed of not less than 62.5 kbps.	
------	--	--

**7. Modification and extension of approval of the type of ~~e-call~~
device-AECD**

7.1	Every type modification to the AECD, including to its manner of attachment to the bodywork, shall be notified to the administrative department that approved the type of AECD. The department may then either:	Every modification to an existing AECD type, shall be notified to the Type Approval Authority which approved the AECD type. The Type Approval Authority shall then either: (a) decide, in consultation with the manufacturer, that a new type-approval is to be granted; or (b) apply the procedure contained in paragraph 7.1.1. (Revision) and, if applicable, the procedure contained in paragraph 7.1.2. (Extension).
7.1.1	Consider that the modifications made are unlikely to have an appreciable adverse effect, and that in any case the AECD still complies with the requirements; or	Revision When particulars recorded in the information documents of Annex 1 have changed and the Type Approval Authority considers that the modifications made are unlikely to have appreciable adverse effect, and that in any case the vehicle still meets the requirements, the modification shall be designated a "revision". In such a case, the Type Approval Authority shall issue the revised pages of the information documents of Annex 1 as necessary, marking each revised page to show clearly the nature of the modification and the date of re-issue. A consolidated, updated version of the information documents of Annex 1, accompanied by a detailed description of the modification, shall be deemed to meet this requirement.
7.1.2	Require a further test report from the technical service responsible for conducting the tests.	Extension The modification shall be designated an "extension" if, in addition to the change of the particulars recorded in the information folder, (a) further inspections or tests are

		<p>required; or</p> <p>(b) any information on the communication document (with the exception of its attachments) has changed; or</p> <p>(c) approval to a later series of amendments is requested after its entry into force.</p>
7.2	<p>Notice of the confirmation of approval, specifying the alterations made, or refusal shall be communicated to the Parties to the 1958 Agreement applying this Regulation in accordance with the procedure specified in paragraph 5.3 above.</p>	<p>Notice of confirmation, extension, or refusal of approval shall be communicated by the procedure specified in paragraph 5.3. above, to the Contracting Parties to the Agreement which apply this Regulation. In addition, the index to the information documents and to the test reports, attached to the communication document of Annex 1, shall be amended accordingly to show the date of the most recent revision or extension.</p>
7.3	<p>Notice of the extension of approval shall be communicated to the Parties to the 1958 Agreement applying this Regulation in accordance with the procedure specified in paragraph 5.3 above.</p>	<p>The Competent Authority issuing the extension of approval shall assign a series number to each communication form drawn up for such an extension.</p>
7.4	<p>The competent authority issuing the extension of approval shall assign a series number to each communication form drawn up for such an extension.</p>	

8. Conformity of production

- 8.1 The conformity of production procedure shall comply with the requirements set out in the Agreement, Appendix 2 (E/ECE/324 E/ECE/TRANS/505/Rev.2).
- 8.2 Every AECD approved under this Regulation shall be so manufactured as to conform to the type approved by meeting the requirements set out in paragraph 6 above.

9. Penalties for non-conformity of production

- 9.1 The approval granted in respect of a type of AECD pursuant to this Regulation may be withdrawn if the requirement laid down in paragraph 8.1 above is not complied with

or if the type of AECD does not satisfy the requirements prescribed in paragraph 8.2 above.

- 9.2 If a Party to the Agreement applying this Regulation withdraws an approval it has previously granted, it shall forthwith so notify the other Contracting Parties applying this Regulation by means of a copy of the communication form bearing at the end, in large letters, the signed and dated annotation “APPROVAL WITHDRAWN”.

10. Production definitively discontinued

If the holder of the approval completely ceases to manufacture a type of AECD approved in accordance with this Regulation, he shall so inform the authority which granted the approval. Upon receiving the relevant communication, that authority shall inform thereof the other Parties to the Agreement which apply this Regulation by means of a copy of the approval form bearing at the end, in large letters, the signed and dated annotation “PRODUCTION DISCONTINUED”.

11. Names and addresses of technical services responsible for conducting approval tests, and of administrative departments

The Parties to the Agreement which apply this Regulation shall communicate to the United Nations Secretariat the names and addresses of the technical services responsible for conducting approval tests and of the administrative departments which grant approval and to which forms certifying approval or refusal or extension or withdrawal of approval, issued in other countries, are to be sent.

Part II VEHICLES WITH REGARD TO THE INSTALLATION OF AN AECD OF AN APPROVED TYPE

12. Definitions

For the purposes of this Regulation:

12.1	“ <i>Emergency call system</i> ” (“ <i>e-call system</i> ”) means the AECD used to send information about an accident in the automatic mode signals received from the sensor(s) of the passive security system or other vehicle systems that are not part of the direct components of the AECDs;	
------	--	--

12.2	“ <i>Time of accident</i> ” means the point in time that corresponds to the signal from the sensor(s) determining the level of deceleration of the vehicle;	“ <i>Triggering signal</i> ” means the signal indicating a road accident, as defined in paragraph 2.3., to the AECD or AECS.
12.3	“ <i>Accident report</i> ” means the set of data, broadcast by the AECD and includes, at least, vehicle make and type designation, vehicle identification number (VIN), coordinates and motion variables of the vehicle at the time of the accident, and the time of the accident.	“ <i>Minimum set of data (MSD)</i> ” means the data set transmitted by the in-vehicle AECS in case of traffic accidents
12.4.	“Public-safety answering point (PSAP)”, means a call center responsible for answering emergency calls emitted by an AECD or AECS.	“Public/Private Safety Answering Point (PSAP)” means a call center responsible for answering calls to an emergency telephone call. It can be of two types <ul style="list-style-type: none"> – Public Safety Answering Point managed by the public services of a Contracting Party to the 58 Agreement; – Private Safety Answering Point managed by a private company.

13. Application for approval of a vehicle type equipped with an AECD which has been approved to Part I of this regulation

- 13.1 The application for approval of a vehicle type with regard to the installation of AECDs shall be submitted by the vehicle manufacturer or by his or her duly accredited representative.
- 13.2 A model of the information document is shown in annex 2.
- 13.3 A vehicle representative of the vehicle type to be approved shall be submitted to the technical service responsible for conducting the approval tests.
- 13.4 The competent authority shall verify the existence of satisfactory arrangements for ensuring effective checks on conformity of production before type approval is granted.

14. Approval

- 14.1 If the vehicle type submitted for approval in accordance with paragraph 13 above meets the requirements of paragraph 15 of this Regulation, approval shall be granted.
- 14.2 An approval number shall be assigned to each type approved. Its first two digits (at present 00) shall indicate the series of amendments incorporating the most recent major technical amendments made to the Regulation at the time of issue of the approval. The same Contracting Party shall not assign the same number to another vehicle type.
- 14.3 Notice of approval or of refusal, or of extension or withdrawal of approval, or of production definitively discontinued of a vehicle type pursuant to this Regulation shall be communicated to the Parties to the Agreement which apply this Regulation by means of a form conforming to the model in annex 4 to this Regulation.
- 14.4 There shall be affixed, conspicuously and in a readily accessible place specified on the approval form, to every vehicle conforming to a vehicle type approved under this Regulation, an international approval mark conforming to the model described in annex 5, consisting of:
- 14.4.1 A circle surrounding the letter “E” followed by the distinguishing number of the country which has granted approval;³
- 14.4.2 The number of this Regulation, followed by the letter “R”, a dash and the approval number to the right of the circle prescribed in paragraph 14.4.1.
- 14.5 If the vehicle conforms to a vehicle type approved under one or more other Regulations annexed to the Agreement in the country which has granted approval under this Regulation, the symbol prescribed in paragraph 14.4.1. need not be repeated; in such a case, the Regulation and approval numbers and the additional symbols shall be placed in vertical columns to the right of the symbol prescribed in paragraph 14.4.1 above.
- 14.6 The approval mark shall be clearly legible and be indelible.
- 14.7 The approval mark shall be placed close to or on the vehicle data plate.

15. Requirements

- 15.1 General

³ The distinguishing numbers of the Contracting Parties to the 1958 Agreement are reproduced in annex 3 to the Consolidated Resolution on the Construction of Vehicles (R.E.3), document ECE/TRANS/WP.29/78/Rev.2/Amend3 – www.unece.org/trans/main/wp29/wp29wgs/wp29gen/wp29resolutions.html.

- 15.1.1 The AECD installed in a vehicle shall be of a type approved under this Regulation.
- 15.1.2 The AECD shall be connected to the vehicle's on-board electrical network, so that the AECD functions in all the required modes, and the backup battery (if fitted) is charged.

15.1.3	The installation of antennas for the AECD shall ensure, when in the operating position, stable signal reception from at least two existing global navigation satellite systems and a stable link to mobile telephone communications networks, providing reception and transmission of signals using GSM-900, GSM-1800, UMTS-900 and UMTS-2000 standards.	The installation of the AECD and its antennas shall be such to obtain: <ul style="list-style-type: none"> - reception of signals from an existing global satellite navigation system and - communication with existing mobile telephone communication networks identified in Annex XXX1.
--------	--	--

15.1.4	The AECD shall enable:	The vehicle shall be equipped with:
15.1.4.1	Transmission of information about the accident after the emergency button has been pressed. The fact that transmission has occurred and the information about the accident shall be recorded by the technical service;	A means to manually activate the AECD, complying with the provisions of paragraph 15.1.5.
15.1.4.2	Two-way voice communications with emergency services through mobile telephone communications networks. The fact that the communication has occurred and that voice communication is possible shall be recorded by the technical service;	An AECD approved to this regulation.
15.1.4.3	Shutdown of other sources of sound in the vehicle, with the exception of the special communications equipment (if fitted), for the period of the voice communications during the e-call.	An automatic shut-down of on-board entertainment sound source, other than that dedicated to the AECD or to other safety-related audible warning signals, during the period of two-way voice communication.
15.1.4.4	The sound level of speakerphone system during the emergency call, characterized by an RLR indicator, shall provide the implementation of full duplex voice connection with the system operator at the AECD operation in ordinary conditions. Necessary value of the specified indicator is	An audio head unit capable of a Receive Loudness Rating (RLR) of more than [2] dB. If adjustable, this RLR shall not be adjustable to a value below [2] dB during operation of the AECD.

	defined by the AECD manufacturer or the vehicle manufacturer. Recommended value of an RLR indicator makes (minus 6 ± 2) dB. Minimum possible value of an RLR indicator makes 2 dB.	
15.1.4.5	During an emergency call the user shouldn't have the possibility of decreasing the loudness of a voice signal of speakerphone system in vehicle salon (cabin) below the level, allowing the full duplex voice connection conducting with the system operator. The minimum sound level is defined by the device manufacturer or the vehicle manufacturer, and its recommended value makes (2 ± 2) dB.	
15.1.4.6	The narrow-band AECD shall conform the requirements of ITU-T P.1100 and correspond to the minimum type of productivity defined in table 1.	OICA believes that the paragraphs 15.1.4.6. to 15.1.4.10, and the tables 1-3 should not be part of the regulation or be in a separate annex.
15.1.4.7	The broadband AECD shall conform the requirements of ITU-T P.1100 and correspond to the minimum type of productivity defined in table 2.	
15.1.4.8	Signal depression in the in and out directions shall be in the borders defined in table 3 for narrow-band and broadband devices of AECDs.	
15.1.4.9	Time of switching necessary for removal of signal depression, brought by the nonlinear processor in the in and out directions, shall be in the borders defined in ITU-T P.1100 and ITU-T P.1110 for narrow-band and broadband devices of AECDs respectively.	
15.1.4.10	In the AECD shall exist the possibility of implementation of automatic control of signal strengthening in the in direction for compensation of low sound level of which can arise in case of road accident (for example if the driver speaks in the direction different from the directional pattern of a microphone). Growth of strengthening by 6 dB shall be reached not more than for	

	200ms. Tests shall be carried out in the presence of radio-noise at a ratio signal/noise for less than 15dB. There shouldn't be a wrong strengthening in the absence of a signal (in the presence of only noise).	
--	---	--

Table 1 – Minimum productivity of the narrow-band e-call devices

Device type	Used speakerphones	Sound level of incoming signal	Minimum production type
E-call device in standard configuration	Provided by the vehicle manufacturer	Nominal level (RLR parameter shall be of (2 ± 2) dB value)	2a
		High level of incoming signal (RLR parameter shall be of $(\text{minus}13\pm 2)$ dB)	2b
E-call device in additional configuration	In-vehicle (front) speakerphones	Nominal level (RLR parameter shall be of (2 ± 2) dB value)	2a
		High level of incoming signal (RLR parameter shall be of $(\text{minus}13\pm 2)$ dB)	2b
	Additional speakerphone	Nominal level (RLR parameter shall be of (2 ± 2) dB value)	2b
	Additional speakerphone	High level of incoming signal (RLR parameter shall be of $(\text{minus}13\pm 2)$ dB)	2c
<p>Note – If the requested sound level of incoming RLR signal, equal $(\text{minus}13\pm 2)$ dB can not be reached by e-call device, than the productivity shall be measured at maximum possible sound level</p>			

Table 2 – Minimum productivity of the broad-band e-call devices

Device type	Used speakerphones	Sound level of incoming signal	Minimum production type
E-call device in standard configuration	Provided by the vehicle manufacturer	Nominal level (RLR parameter shall be of (2 ± 2) dB value)	2a
		High level of incoming signal (RLR parameter shall be of $(\text{minus}13\pm 2)$ dB)	2b
E-call device in additional configuration	In-vehicle (front) speakerphones	Nominal level (RLR parameter shall be of (2 ± 2) dB value)	2a
		High level of incoming signal (RLR parameter shall be of $(\text{minus}13\pm 2)$ dB)	2b
	Additional speakerphone	Nominal level (RLR parameter shall be of (2 ± 2) dB value)	2b
	Additional speakerphone	High level of incoming signal (RLR parameter shall be of $(\text{minus}13\pm 2)$ dB)	2c

Note – If the requested sound level of incoming RLR signal, equal (minus 13 ± 2) dB can not be reached by VS, than the productivity shall be measured at maximum possible sound level

Table 3 – Maximum possible signal depression in decibels

Production type				
Full duplex	Partial duplex			Absence of duplex
1	2a	2b	2c	3
≤ 5	≤ 8	≤ 11	≤ 13	> 13

15.1.4.11	In the e-call device shall exist the possibility of implementation of automatic sound level strengthening of incoming call to 15 dB according to increase noise level in salon (cabin) of the vehicle. The increase in strengthening at 6 dB has to be carried out not later 2 sec. after the corresponding change of noise level.	OICA believes that paragraphs 15.1.4.11. to 15.1.4.14. should not be part of the regulation or be in a separate annex.
15.1.4.12	Signal delay of in and out directions (the sum of in and out directions delays) shall be in borders defined in ITU-T P.1100 and ITU-T P.1110 for narrow-band and broadband devices of e-call devices respectively.	
15.1.4.13	Echo depression (TCLw) in the conditions of surrounding silence shall be for 50 dB or more at nominal level of loudness. At a maximum level of loudness level the depression of TCLw shall exceed 50 dB.	
15.1.4.14	The implementation of requirements for sound quality in a vehicle cabin is confirmed by compliance to the ETSI EG 202 396-1 standard and the following ITU standards: ITU-T P.1100, ITU-T P.1110, ITU-T P.501, ITU-T P.79, ITU-T P.340, ITU-T P.800, ITU-T P.800.1, ITU-T P.830, ITU-T P.831, ITU-T P.832, ITU-T P.835.	

15.1.5 Emergency call control

15.1.5.1	An emergency call button shall be installed in the direct line of sight from the driver's seat and the front passenger seat – fiftieth percentile male (if the vehicle structure provides for the front passenger to sit next to the driver's seat). It shall be possible to reach the emergency button call without undoing seat belts.	Vehicles fitted with an AECD shall be equipped with an emergency call control complying with the relevant requirements of UN R121.
15.1.5.2	The emergency call button shall be protected from accidental activation. A mechanical means of protection shall be used.	
15.1.5.3	The emergency call button shall be illuminated.	
15.1.5.4	The emergency call button shall bear an identifying symbol [in accordance with Regulation No. 121].	

15.1.6	E-call device optical status indicator	Emergency call warning signal
15.1.6.1	A continuous (non-blinking) red optical indicator, also visible during daylight [in accordance with Regulation No. 121] shall be used.	Vehicles fitted with an AECD shall be equipped with an emergency call warning signal complying with the relevant requirements of UN R121.

15.1.6.2	The optical indicator shall be placed in the direct line of sight from the seats of the driver and the front passenger, meeting the criteria set in paragraph 15.1.5.1 above.	
15.1.6.3	The optical indicator shall come on:	The emergency call warning signal shall:
15.1.6.3.1	Briefly (between 3 and 10 seconds) when power is applied to the vehicle's electrical equipment when the ignition (start) switch is put in the "On" (operating) position;	be activated either when the ignition (start) switch is turned to the "on" (run) position or when the ignition (start) switch is in a position between the "on" (run) and "start" that is designated by the manufacturer as a check position (initial system (power-on)). This requirement does not apply to warning signals shown in a common space.
15.1.6.3.2	Constantly when there is a fault in the system that prevents it complying with the requirements of paragraph 15.1.4 above,	be a [constant yellow] optical warning signal in case of AECD failure that prevents the requirements of this Regulation of being met and shall remain on as long as the fault persists when the ignition (start) switch is put in the "On" (operating) position.
15.1.6.3.3.		be a [flashing yellow] optical warning signal in case of AECD operation per Paragraph 15.2.3.

15.1.6.4	The optical indicator shall have an identifying symbol [in accordance with Regulation No. 121].	
15.1.6.5	The optical indicator may be usefully aligned with the emergency call button.	
15.1.7	Optical indicators meeting these requirements may be omitted if it is possible to indicate any faults in the e-call device each time power is applied to the vehicle's electrical equipment when the ignition (start) switch is put in the "On" (operating) position by means of another optical indicator as well as by a display on the instrument panel of textual information on the malfunction of the e-call device which remains displayed as long as the fault persists when the ignition (start) switch is put in the "On" (operating) position.	

15.2	Additional specifications for e-call systems	Additional requirements for vehicles equipped with AECD
15.2.1	The specifications apply to vehicles of category M ₁ , covered by Regulations Nos. 94 and (or) 95, and those of category N ₁ , covered by Regulation No. 95.	

15.2.2	The type of vehicle with regard to the installation of an e-call system is, for category M ₁ , the vehicle type covered by Regulations Nos. 94 or 95; and for category N ₁ , the vehicle type covered by Regulation No. 95.	
--------	---	--

15.2.3	The e-call system shall enable:	Any vehicle fitted with an AECD complying with the definition of paragraph 2.1. above shall meet the performance requirements contained in paragraphs 15.2.3. to 15.2.3.2
15.2.3.1	Automatic transmission of information about the accident at the time of the accident. The fact that transmission has occurred and the information about the accident shall be recorded by the technical service:	The AECD shall demand in-band modem communication at the latest [1 second] after reception of the triggering signal defined in paragraph 12.2. The triggering signal shall be generated by one of the following means:
15.2.3.1.1	When simulating a frontal collision of the vehicle during tests under Regulation No. 94. If the vehicle is not covered by Regulation No. 94, frontal collision shall be simulated during tests under Regulation No. 12.	Performance or simulation of a frontal collision. In the case of a simulation, the logic signal can be generated according to a test report established during a Regulation No. 94 frontal collision;
15.2.3.1.2	When simulating a lateral collision of the vehicle during tests under Regulation No. 95.	Performance or simulation of a lateral collision. In the case of a simulation, the logic signal can be generated according to a test report established during a Regulation No. 95 lateral collision.
15.2.3.2	On completing the tests specified in paragraph 15.2.3.1, retention of functionality and two-way voice communications with the emergency services through mobile telephone communications networks. The fact that the communication has occurred and that voice communication is possible shall be recorded by the technical service.	When performing the tests specified in paragraph 15.2.3.1., the AECD shall fulfil the requirements of paragraph 6.6.2. (data batch transmission) and 6.6.5. (reception of mobile phone networks signals). For the purpose of this paragraph, one of the mobile telephone communication networks identified in Annex XXX1 shall be simulated. The vehicle manufacturer shall demonstrate, through the use of documentation, compliance with all the other mobile telephone communication networks identified in Annex XXX1 to this Regulation. Any such documentation shall be appended to the test report.

16. Modifications and extension of approval of a vehicle type equipped with an AECD which has been approved to Part I of this regulation

- 16.1 Every modification of the vehicle type shall be notified to the administrative department which approved the vehicle type. The department may then either:
- 16.1.1 Consider that the modifications made are unlikely to have an appreciable adverse effect, and that in any case the vehicle still complies with the requirements; or
- 16.1.2 Require a further test report from the technical service responsible for conducting the tests.
- 16.2 Notice of the confirmation of approval, specifying the alterations made, or refusal shall be communicated to the Parties to the Agreement applying this Regulation by means of a form conforming to the model in annex XXX to this Regulation.
- 16.3 The competent authority issuing the extension of approval shall assign a series number to each communication form drawn up for such extension.

17. Conformity of production

- 17.1 The conformity of production procedure shall comply with the requirements set out in the Agreement, Appendix 2 (E/ECE/324 E/ECE/TRANS/505/Rev.2).
- 17.2 Every vehicle approved under this Regulation shall be so manufactured as to conform to the type approved by meeting the requirements set out in paragraph 15 above.

18. Penalties for non-conformity of production

- 18.1 The approval granted in respect of a vehicle type pursuant to this Regulation may be withdrawn if the requirement laid down in paragraph 17.1 above is not complied with or if the vehicle fails to pass the checks prescribed in paragraph 17.2 above.
- 18.2 If a Party to the Agreement which applies this Regulation withdraws an approval it has previously granted, it shall forthwith so notify the other Contracting Parties applying this Regulation by means of a copy of the approval form bearing at the end, in large letters, the signed and dated annotation "APPROVAL WITHDRAWN".

19. Production definitively discontinued

If the holder of the approval completely ceases to manufacture a vehicle type approved in accordance with this Regulation, he or she shall so inform the authority which granted the approval. Upon receiving the relevant communication, that authority shall inform thereof the other Parties to the Agreement which apply this Regulation by means of a copy of the approval form bearing at the end, in large letters, the signed and dated annotation "PRODUCTION DISCONTINUED".

20. Names and addresses of technical services responsible for conducting approval tests, and of administrative departments

The Parties to the Agreement which apply this Regulation shall communicate to the United Nations Secretariat the names and addresses of the technical services responsible for conducting approval tests and of the administrative departments which grant approval and to which forms certifying approval or refusal, or extension or withdrawal of approval, issued in other countries, are to be sent.

Part III VEHICLES WITH REGARD TO THEIR AECS

21. Definitions

21.1. "Accident *Emergency Call System (AECS)*" means equipment within the vehicle that provides or has access to the in-vehicle data required to perform an emergency call, made either automatically by means of the activation of in-vehicle sensors or manually, which carries a standardised minimum set of data and establishes an audio channel between the vehicle and the eCall Safety Answering Point via public mobile wireless communication networks.

21.2. "*Common space*" means an area on which two or more information functions (e.g. symbol) may be displayed but not simultaneously.

22. Application for approval of a vehicle type equipped with an AECS

22.1 The application for approval of a vehicle type with regard to its AECS shall be submitted by the vehicle manufacturer or by his or her duly accredited representative.

22.2 A model of the information document is shown in annex XXX.

22.3 A vehicle representative of the vehicle type to be approved shall be submitted to the technical service responsible for conducting the approval tests.

22.4 The competent authority shall verify the existence of satisfactory arrangements for ensuring effective checks on conformity of production before type approval is granted.

23. Approval

23.1 If the vehicle type submitted for approval in accordance with paragraph 22 above meets the requirements of paragraph 24 of this Regulation, approval shall be granted.

23.2 An approval number shall be assigned to each type approved. Its first two digits (at present 00) shall indicate the series of amendments incorporating the most recent major technical amendments made to the Regulation at the time of

issue of the approval. The same Contracting Party shall not assign the same number to another vehicle type.

- 23.3 Notice of approval or of refusal, or of extension or withdrawal of approval, or of production definitively discontinued of a vehicle type pursuant to this Regulation shall be communicated to the Parties to the Agreement which apply this Regulation by means of a form conforming to the model in annex 4 to this Regulation.
- 23.4 There shall be affixed, conspicuously and in a readily accessible place specified on the approval form, to every vehicle conforming to a vehicle type approved under this Regulation, an international approval mark conforming to the model described in annex 5, consisting of:
- 23.4.1 A circle surrounding the letter “E” followed by the distinguishing number of the country which has granted approval;⁴
- 23.4.2 The number of this Regulation, followed by the letter “R”, a dash and the approval number to the right of the circle prescribed in paragraph 23.4.1.
- 23.5 If the vehicle conforms to a vehicle type approved under one or more other Regulations annexed to the Agreement in the country which has granted approval under this Regulation, the symbol prescribed in paragraph 23.4.1. need not be repeated; in such a case, the Regulation and approval numbers and the additional symbols shall be placed in vertical columns to the right of the symbol prescribed in paragraph 23.4.1 above.
- 23.6 The approval mark shall be clearly legible and be indelible.
- 23.7 The approval mark shall be placed close to or on the vehicle data plate.

24. Requirements

24.1 General

Any vehicle equipped with an AECS complying with the definition of paragraph 21.1. above shall meet the performance requirements contained in paragraphs 24.1. to 24.3.2.2.

- 24.1.1 The AECS shall be such to function in all the required modes.
- 24.1.2 The installation of the AECS antennas shall be such to obtain:
- reception of signals from an existing global satellite navigation system, and
 - communication with existing mobile telephone communication networks identified in Annex XXX1.
- 24.1.3 The vehicle shall be equipped with:
- 24.1.3.1 A means to manually activate the AECS, complying with the provisions of paragraph 24.1.4.

⁴ The distinguishing numbers of the Contracting Parties to the 1958 Agreement are reproduced in annex 3 to the Consolidated Resolution on the Construction of Vehicles (R.E.3), document ECE/TRANS/WP.29/78/Rev.2/Amend3 – www.unece.org/trans/main/wp29/wp29wgs/wp29gen/wp29resolutions.html.

-
- 24.1.3.2 An automatic shut-down of on-board entertainment sound source, other than that dedicated to the AECD or to other safety-related audible warning signals, during the period of two-way voice communication.
- 24.1.3.3 An audio head unit capable of a Receive Loudness Rating (RLR) of more than [2] dB. If adjustable, this RLR shall not be adjustable to a value below [2] dB during operation of the AECS.
- 24.1.4 Emergency call control
- 24.1.4.1 The vehicle shall be equipped with an emergency call control complying with the relevant requirements of UN R121.
- 24.1.5 Emergency call warning signal
- 24.1.5.1 The vehicle shall be equipped with an emergency call warning signal complying with the relevant requirements of UN R121.
- 24.1.5.2 The emergency call warning signal shall:
- 24.1.5.2.1 be activated either when the ignition (start) switch is turned to the "on" (run) position or when the ignition (start) switch is in a position between the "on" (run) and "start" that is designated by the manufacturer as a check position (initial system (power-on)). This requirement does not apply to warning signals shown in a common space.
- 24.1.5.2.2 be a [constant yellow] optical warning signal in case of AECS failure that prevents the requirements of this Regulation of being met, and shall remain on as long as the fault persists when the ignition (start) switch is put in the "On" (operating) position. This requirement does not apply to warning signals shown in a common space.
- 24.1.5.2.3 be a [flashing yellow] optical warning signal in case of AECS operation per Paragraph 24.2.3. This requirement does not apply to warning signals shown in a common space.
- 24.2 Functional requirements
- 24.2.1 Performance of an AECS
- The AECS shall demand voice modem communication at the latest [1 second] after reception of the triggering logic signal defined in paragraph 12.2.
- The AECS shall fulfil the following requirements:
- 24.2.1.1 Requirements of paragraph 6.6.2. (data batch transmission)
- 24.2.1.2 Requirements of paragraph 6.6.5. (reception of mobile phone networks signals)
- 24.2.1.3 Communicate the minimum set of data (MSD)
- 24.2.1.3.1 The MSD shall contain at least data described in annex [XXX].:
- This shall be demonstrated by compliance with the requirements of Annex [11]
- 24.2.2 Generation of the triggering logic signal
- The triggering logic signal shall be generated by at least one of the following events:
- 24.2.2.1. Occurrence of a frontal collision according to Regulation No. 94 (frontal collision); or

- 24.2.2.2. Occurrence of a lateral collision according to Regulation No. 95 (lateral collision); or
- 24.2.2.3. Activation of the AECS control.
- 24.3 AECS test procedure
 - 24.3.1 Performance requirements
 - 24.3.1.1 Testing equipment:
 - a) A hardware-in-the-loop environment may be used to simulate the vehicle systems, including the components of an AECS.
 - b) Alternatively the test can be carried out with a representative vehicle.
 - c) Test receivers may be used to simulate a mobile telephone communication network identified in Annex XXX1 and one of the PSAP identified in Annex XXX2.
 - 24.3.1.2 The manufacturer shall demonstrate that the MSD is transmitted and the emergency call is performed when the triggering logic signal is applied to the AECS testing equipment.
 - 24.3.2 Testing the generation of a triggering logic signal
 - 24.3.2.1. The manufacturer shall carry out or simulate the following tests with a vehicle that is representative of the vehicle type to be approved to demonstrate that the triggering logic signal is generated:
 - a) A frontal collision according to Regulation No. 94 (frontal collision); or
 - b) A lateral collision according to Regulation No. 95 (lateral collision); or
 - c) Activation of the AECS control.
 - 24.3.2.2 as an alternative to paragraph 24.3.2.1., the manufacturer may present to the type-approval authority a certificate established in accordance with the model set out in Annex XXX.

25. Modifications and extension of approval of a vehicle type equipped with an AECS

- 25.1 Every modification to an existing AECS type, including its attachment to the vehicle, shall be notified to the Type Approval Authority which approved the AECS type. The Type Approval Authority shall then either:
 - (a) decide, in consultation with the manufacturer, that a new type-approval is to be granted; or
 - (b) apply the procedure contained in paragraph 7.1.1. (Revision) and, if applicable, the procedure contained in paragraph 7.1.2. (Extension).
- 25.2. Revision

When particulars recorded in the information documents of Annex 1 have changed and the Type Approval Authority considers that the modifications made are unlikely to have appreciable adverse effect, and that in any case the

vehicle still meets the requirements, the modification shall be designated a "revision".

In such a case, the Type Approval Authority shall issue the revised pages of the information documents of Annex 1 as necessary, marking each revised page to show clearly the nature of the modification and the date of re-issue. A consolidated, updated version of the information documents of Annex 1, accompanied by a detailed description of the modification, shall be deemed to meet this requirement

25.3. Extension

The modification shall be designated an "extension" if, in addition to the change of the particulars recorded in the information folder,

- (a) further inspections or tests are required; or
- (b) any information on the communication document (with the exception of its attachments) has changed; or
- (c) approval to a later series of amendments is requested after its entry into force.

25.2 Notice of confirmation, extension, or refusal of approval shall be communicated by the procedure specified in paragraph 5.3. above, to the Contracting Parties to the Agreement which apply this Regulation. In addition, the index to the information documents and to the test reports, attached to the communication document of Annex 1, shall be amended accordingly to show the date of the most recent revision or extension.

25.3 The Competent Authority issuing the extension of approval shall assign a series number to each communication form drawn up for such an extension.

26. Conformity of production

26.1 The conformity of production procedure shall comply with the requirements set out in the Agreement, Appendix 2 (E/ECE/324 E/ECE/TRANS/505/Rev.2).

26.2 Every vehicle approved under this Regulation shall be so manufactured as to conform to the type approved by meeting the requirements set out in paragraph 24 above.

27. Penalties for non-conformity of production

27.1 The approval granted in respect of a vehicle type pursuant to this Regulation may be withdrawn if the requirement laid down in paragraph 26.1 above is not complied with or if the vehicle fails to pass the checks prescribed in paragraph 26.2 above.

27.2 If a Party to the Agreement which applies this Regulation withdraws an approval it has previously granted, it shall forthwith so notify the other Contracting Parties applying this Regulation by means of a copy of the approval form bearing at the end, in large letters, the signed and dated annotation "APPROVAL WITHDRAWN".

28. Production definitively discontinued

If the holder of the approval completely ceases to manufacture a vehicle type approved in accordance with this Regulation, he or she shall so inform the authority which granted the approval. Upon receiving the relevant communication, that authority shall inform thereof the other Parties to the Agreement which apply this Regulation by means of a copy of the approval form bearing at the end, in large letters, the signed and dated annotation "PRODUCTION DISCONTINUED".

29. Names and addresses of technical services responsible for conducting approval tests, and of administrative departments

The Parties to the Agreement which apply this Regulation shall communicate to the United Nations Secretariat the names and addresses of the technical services responsible for conducting approval tests and of the administrative departments which grant approval and to which forms certifying approval or refusal, or extension or withdrawal of approval, issued in other countries, are to be sent.

Annex 1

Information document relating to the type approval of an e-call device

The following information, if applicable, shall be supplied in triplicate and shall include a list of contents.

Any drawings shall be supplied in appropriate scale and in sufficient detail on size A4 paper or on a folder of A4 format.

Photographs, if any, shall show sufficient detail.

1. Make (trade name of manufacturer):.....
2. Type and general commercial description(s):
3. Means of identification of type, if marked on the device:.....
4. Name and address of manufacturer:
5. Location of and method of affixing the approval mark:
6. Address(es) of assembly plant(s):
7. Arrangement (indicate components included on delivery):
8. Description of method(s) of attachment to the vehicle:
9. Sufficiently detailed drawings to identify the complete device, including installation instructions; the position for the type-approval mark must be indicated on the drawings:.....

Annex 2

Information document relating to the type approval of a vehicle with regard to the installation of e-call devices

The following information, if applicable, shall be supplied in triplicate and shall include a list of contents.

Any drawings shall be supplied in appropriate scale and in sufficient detail on size A4 paper or on a folder of A4 format.

Photographs, if any, shall show sufficient detail.

General

1. Make (trade name of manufacturer):.....
2. Type and general commercial description(s):
3. Means of identification of type, if marked on the vehicle:
4. Location of the marking:.....
5. Location of and method of affixing the approval mark:
6. Category of vehicle:
7. Name and address of manufacturer:.....
8. Address(es) of assembly plant(s):
9. Photograph(s) and/or drawing(s) of a representative vehicle:.....
10. E-call device/system
 - 10.1 Make (trade name of manufacturer):.....
 - 10.2 Type and general commercial description(s):
 - 10.3 Arrangement (indicate components included in delivery):
 - 10.4 Description of means of automatic transmission of information about the accident (if fitted):.....
 - 10.5 Description of method(s) of attachment to the vehicle:
 - 10.6 Drawing(s) showing the position of the e-call device/system:.....

Annex 3

Information document relating to the type approval of a vehicle with regard to AECS

The following information, if applicable, shall be supplied in triplicate and shall include a list of contents.

Any drawings shall be supplied in appropriate scale and in sufficient detail on size A4 paper or on a folder of A4 format.

Photographs, if any, shall show sufficient detail.

General

1. Make (trade name of manufacturer):.....
2. Type and general commercial description(s):
3. Means of identification of type, if marked on the vehicle:
4. Location of the marking:.....
5. Location of and method of affixing the approval mark:
6. Category of vehicle:
7. Name and address of manufacturer:.....
8. Address(es) of assembly plant(s):
9. Photograph(s) and/or drawing(s) of a representative vehicle:.....
10. E-call device/system
- 10.1 Make (trade name of manufacturer):.....
- 10.2 Type and general commercial description(s):
- 10.3 Arrangement (indicate components included in delivery):
- 10.4 Description of means of automatic transmission of information about the accident (if fitted):.....

ANNEX XXX:

Model

**Manufacturer's Certificate of compliance with the
AECS logic triggering signal requirements**

(Manufacturer):

(Address of the manufacturer):

Certifies that

**The vehicle types listed in annex to this Certificate are in compliance with the provisions of
Regulation ECE-R ??? relating to the generation of the AECS logic triggering signal.**

Done at [..... Place]

On [..... Date]

[Signature] [Position]

Annexes:

- List of vehicle types to which this Certificate applies

14. Date:.....
15. Signature:
16. The list of documents deposited with the administrative service which has granted approval, is annexed to this communication and may be obtained on request.

Annex 4

Communication

(Maximum format: A4 (210 x 297 mm))



Issued by: Name of administration:

.....

- concerning:²
- Approval granted
 - Approval extended
 - Approval refused
 - Approval withdrawn
 - Production definitively discontinued

of a type of vehicle with regard to the installation of e-call devices pursuant to Regulation No. XXX

Approval No. ... Extension No. ...

1. Make (trade name of manufacturer):.....
2. Type and general commercial description(s):
3. Means of identification of type, if marked on the vehicle:
4. Location of that marking:.....
5. Position of the approval mark:
6. Category of vehicle: (M₁; M₂; M₃; N₁; N₂; N₃)²
- 6.1 Vehicle is/is not covered by Regulations Nos. 12, 94 or 95²
7. Name and address of manufacturer:.....
8. Address(es) of assembly plant(s):
9. E-call device/system²
- 9.1 Make (trade name of manufacturer):.....
- 9.2 Type and general commercial description(s):
- 9.3 Arrangement (indicate components included):
- 9.4 Automatic transmission of information about accidents: Yes/No²

¹ Distinguishing number of the country which has granted/extended/refused/withdrawn approval (see approval provisions in the Regulations).

² Delete as appropriate.

10. Technical service responsible for testing:
11. Date of test report:
12. Number of test report:
13. Place:.....
14. Date:.....
15. Signature:
16. The list of documents deposited with the administrative service which granted approval is annexed to this communication and may be obtained on request.

Annex XXX

Communication

(Maximum format: A4 (210 x 297 mm))



Issued by: Name of administration:

.....
.....
.....

concerning:⁴ Approval granted
 Approval extended
 Approval refused
 Approval withdrawn
 Production definitively discontinued

of a type of vehicle with regard to AECS

Approval No. ... Extension No. ...

1. Make (trade name of manufacturer):.....
2. Type and general commercial description(s):
3. Means of identification of type, if marked on the vehicle:
4. Location of that marking:.....
5. Position of the approval mark:
6. Category of vehicle: (M₁; M₂; M₃; N₁; N₂; N₃)²
7. Name and address of manufacturer:.....
8. Address(es) of assembly plant(s):
9. E-call device/system²
- 9.1 Make (trade name of manufacturer):.....
- 9.2 Type and general commercial description(s):
- 9.3 Arrangement (indicate components included):
- 9.4 Automatic transmission of information about accidents: Yes/No²
10. Technical service responsible for testing:
11. Date of test report:
12. Number of test report:

³ Distinguishing number of the country which has granted/extended/refused/withdrawn approval (see approval provisions in the Regulations).

⁴ Delete as appropriate.

13. Place:.....
14. Date:.....
15. Signature:
16. The list of documents deposited with the administrative service which granted approval is annexed to this communication and may be obtained on request.

Annex 5

Arrangement of approval mark

(See paragraphs 5.4 and 14.4 of the Regulation.)

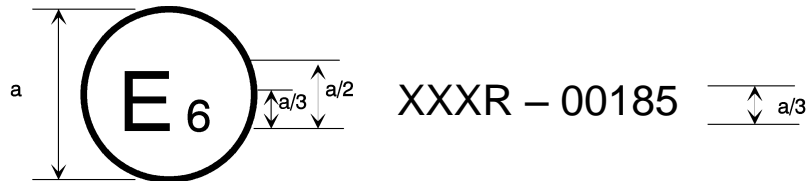

The above approval mark affixed to an e-call device/vehicle, indicates that this type of e-call device/vehicle with regard to the installation of an e-call device has been approved in Belgium (E6) pursuant to Regulation No. XXX. The first two digits of the approval number indicate that the approval was granted in accordance with the requirements of Regulation No. XXX in their original form.

[Annex 6

Test methods for climate resistance.

1. Definitions

For the purposes of this Annex:

1.1 “*Conductive industrial radio noise*” stands for electromagnetic disturbance, which energy is transmitted through one or several conductors;

1.2 “*Minimum data set*” stands for the data set transmitted by the In-Vehicle Emergency Call System/Device in case of traffic accidents, which includes information on coordinates and parameters of movement of the emergency vehicle, time of the accident, vehicles VIN-code and other information necessary for the emergency reaction.

1.3 “*Equipment resistance*” stands for the ability of the equipment to maintain its parameters within the specified tolerances after the impact of climatic (mechanical) factors;

1.4. “*Equipment durability*” stands for the ability of the equipment to maintain its parameters within the specified tolerances during and after the impact of climatic (mechanical) factors;

1.5. “*Equipment stability*” stands for the ability of the equipment to maintain its parameters within the specified tolerances during the impact of climatic (mechanical) factors.

2. Test conditions

2.1 In-Vehicle Emergency Call System/Device tests under the impact of climatic factors are carried out under climatic conditions characterized by the values of the factors parameters specified in the relevant clauses of test methods as described in section 4.

In-Vehicle Emergency Call System/Device components which are not in similar operating conditions are tested separately in accordance with the operating conditions established for each of them. It is allowed to test the In-Vehicle Emergency Call System/Device in a full set under the most stringent standards of testing regimes.

2.2 The In-Vehicle Emergency Call System/Device performance check during the tests should be carried out with the use of a special diagnostic programme.

2.2.1 The diagnostic programme is developed by In-Vehicle Emergency Call System/Device manufacturer and is supplied upon a separate request.

2.2.2 The In-Vehicle Emergency Call System/Device diagnostic programme should have the following functionalities:

- the possibility to choose the diagnostic tests by the user;
- the possibility to conduct the tests (test sequences, tests starting and stopping, setting In-Vehicle Emergency Call System/Device diagnosing parameters, etc.) in manual and automatic modes;
- the possibility to determine the number of automatic testing cycles from 1 to 10 000;
- to display test results in a short form (all tests are successful, an error is detected After testing) on a computer screen and in a text file (the text file format is specified by the In-Vehicle Emergency Call System/Device manufacturer)

- to display test results in a detailed form (the test result and the additional information determined by the In-Vehicle Emergency Call System/Device manufacturer for each completed test) on a computer screen and in a text file (the text file format is specified by the In-Vehicle Emergency Call System/Device manufacturer)

- to conduct the In-Vehicle Emergency Call System/Device test in accordance with the following requirements:

2.2.2.1 The change of the In-Vehicle Emergency Call System/Device to a testing mode should be possible only after the corresponding action for switching on the test mode on the vehicle party, with external power source, without any movement of the vehicle within the last minute and at the engaged ignition.

2.2.2.2 The change of In-Vehicle Emergency Call System/Device from the testing mode to a road accident mode should take after finishing the test or, if the road accident was indicated, after ignition or external power source shutdown.

2.2.2.3 The message exchange between the In-Vehicle Emergency Call System/Device in a test mode and a system operator should be organised by means of an in-band modem during a call at an ECALL_TEST_NUMBER;

2.2.2.4 For the In-Vehicle Emergency Call System/Device installed as extra equipment, changing to the test mode from the road accident mode should be done by pushing the “Extra functions” button;

2.2.2.5 For the In-Vehicle Emergency Call System/Device installed as standard equipment, changing to the test mode from the road accident mode should be done by the use of user’s interface enabled in the vehicle;

The operation instruction for entering the testing mode should be presented at a vehicle’s user guide;

2.2.2.6 If In-Vehicle Emergency Call System/Device is not used for extra telematic services except the emergency response service and is registered by means of user’s interface To enabled in a vehicle and the testing mode is switched on then In-Vehicle Emergency Call System/Device should stop the Network registration after the test;

2.2.2.7 If the In-Vehicle Emergency Call System/Device is used for extra telematic services besides the emergency response service and is registered in the Network by means of user’s interface To enabled in a vehicle and the test mode is switched on then the device Network registration behavior after the test should be determined by the manufacturer;

2.2.2.8 If the In-Vehicle Emergency Call System/Device is not used for extra telematic services besides the emergency response service and is registered in the Network by means of pushing the “Extra functions” button then the further The Network registration for the stated variants of In-Vehicle Emergency Call System/Devices functioning will be possible no sooner than after the time interval stated in the TEST_REGISTRATION_PERIOD;

If “0” value is set in the TEST_REGISTRATION_PERIOD then there will be no limit for the further registration of the In-Vehicle Emergency Call System/Device;

2.2.2.9 If the In-Vehicle Emergency Call System/Device is used for extra telematic services besides the emergency response service and is registered in the Network by means of pushing the “Extra functions” button then the rules for the further registration will be determined by the manufacturer.

2.2.2.10 The testing mode should be stopped automatically if the vehicle with its ignition engaged moves on a distance longer than it is set in parameters TEST_MODE_END_DISTANCE. Thus the accuracy of determination of distance has to be no more than 45 m.

If coordinates of a point in which the testing mode was engaged, were not determined, the mode has to be disconnected on the set distance from the point in which coordinates of the vehicle were determined for the first time since engaging of ignition.

If data acquisition from the global navigation satellite system receiver is not possible then other methods for covered distance detection may be used.

2.2.2.11 Following tests should be implemented in testing mode:

- microphone connection test. For example, the In-Vehicle Emergency Call System/Device plays a voice prompt with the request to the tester to say the phrase, records the sound into entire memory, plays back the sound and asks the tester to push the needed button (buttons) in case the sound is correct;
- speaker (speakers) connection test. For example, the In-Vehicle Emergency Call System/Device plays a sound or a voice prompt through the left and right speakers and requests the tester to push the needed button (buttons) in case the sound is correct;
- user's interface unit detailed test. For example, the In-Vehicle Emergency Call System/Device plays a voice request to push needed buttons in a specified order. In addition the In-Vehicle Emergency Call System/Device asks the tester to confirm the correct work of status indicators of the In-Vehicle Emergency Call System/Device.
- standby battery test, in case if there exists one and there is a possibility to do a standby battery test;
- performance test of automatic road accident identification sensor (mechanism) (only for vehicles of category M1), that is obligatory for this category of vehicles;

Note – If a base vehicle system is used as a road accident data source, then the use of previous data of performance of automatic road accident identification sensor (mechanism) is applied; data received during the period between engaging the ignition (for example, performance data of automatic road accident identification sensor (mechanism), received during the diagnostic process of base vehicle systems, started after engaging the ignition).

2.2.2.12 On completing the In-Vehicle Emergency Call System/Device test, the results should be transferred to a system operator by means of the in-band modem at a call on ECALL_TEST_NUMBER.

The minimum data set of the e-call test results should be posed in a results format according to Appendix A.

2.2.2.13 The minimum data set of e-call test results should be transferred with a stated identification "test call" according to Appendix A.

2.2.2.14 Exiting the test mode by the In-Vehicle Emergency Call System/Device should be conducted as follows:

- after transferring the minimum data set of test results from the In-Vehicle Emergency Call System/Device to the system operator;
- under disabling the external power source;
- under moving the vehicle away (with engaged ignition) from the point of enabling the test mode for the distance more than it is set in parameters TEST_MODE_END_DISTANCE (configurable parameter).
- if extra conditions of exit are set.

2.2.2.15 Before exiting the test mode by the In-Vehicle Emergency Call System/Device it should take the testing results across the tester by means of an In-Vehicle Emergency Call System/Device status indicator by playing a specified voice message.

- to provide the possibility of taking information on the version of a hardware platform and software of all In-Vehicle Emergency Call System/Device units, including versions of hardware platform and software of a navigation system receiver, a GSM/UMTS modem, an in-band modem, a control processor;
- to provide the readability and entire memory cleaning of the In-Vehicle Emergency Call System/Device;

- to provide the readability and the possibility of setting parameters of the In-Vehicle Emergency Call System/Device;
- to provide a software update of all In-Vehicle Emergency Call System/Device units.

2.2.3 If electric signal transducers (for example, USB-CAN signal transducer) are needed for the performance assurance, then the specified transducers should be provided by the manufacturer as a set with a test programme.

3. Test equipment

3.1 Test equipment should provide the command capability (To enable/off, changing modes and etc.) and the capability of reading the testing In-Vehicle Emergency Call System/Device under specific climatic factors, if such options are anticipated in a test method. The items and characteristics of the test equipment are in the following table 1.

Table 1. The items and characteristics of the test equipment

Equipment name	Requested characteristics of the test equipment
Moisture chamber	Temperature — from 25°C to 40°C; humidity relative — from 80 % to 95 %
Heat chamber*	Temperature — to 90°C; an accuracy of temperature control in effective chamber storage not more than 3°C
Cold chamber*	Temperature — from plus 5° to minus 70°C; an accuracy of temperature control in effective chamber storage not more than 3°C
Dust chamber	IEC 529:1989 (section 13, Figure 2)
Storage for water drops pickup	IEC 529:1989 (section 14, Figure 3)
Water storage	IEC 529:1989 (section 14, Figure 8)
Stand for adjusting and control of the In-Vehicle Emergency Call System/Device	Figure 1
* The usage of two-section heat and cold chambers, providing the required limits of high and low temperature with specified accuracy of temperature control, is acceptable.	

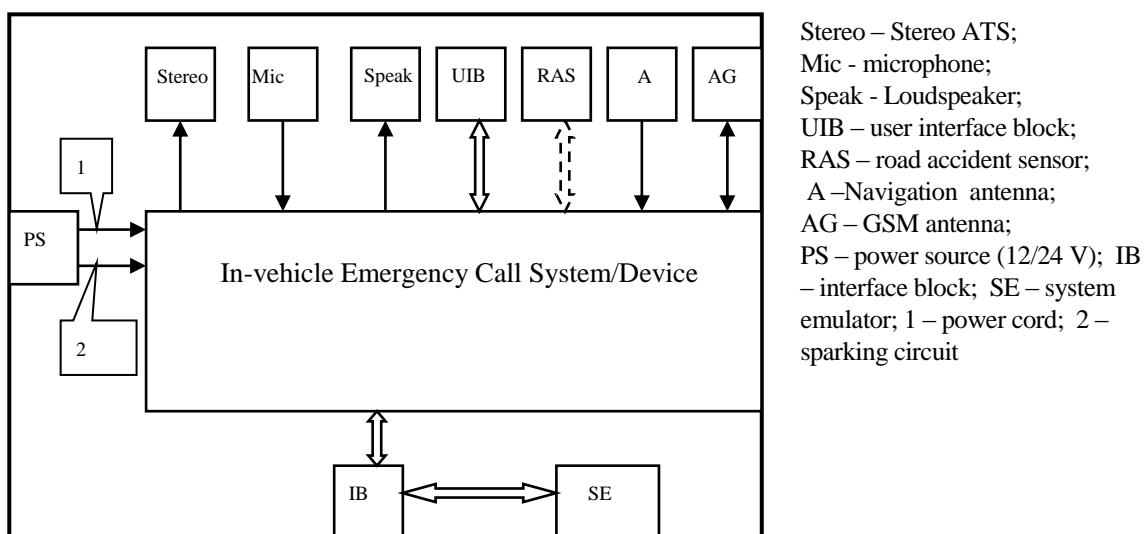

Figure 1 – General In-Vehicle Emergency Call System/Device connection diagram

1. Test procedure

4.1 Operational documentation completeness check.

The In-Vehicle Emergency Call System/Device installed in the standard equipment configuration is considered as having passed the test if the composition of the set of documents submitted to the test conforms to the one set by the vehicle manufacturer.

4.2 The In-Vehicle Emergency Call System/Device completeness check.

The In-Vehicle Emergency Call System/Device, performed as base equipment, is considered as having passed the test if the In-Vehicle Emergency Call System/Device delivery set corresponds to the stated by a vehicle manufacturer one.

4.3 The In-Vehicle Emergency Call System/Device marking check.

The In-Vehicle Emergency Call System/Device marking compliance check is carried out after each kind of system tests for climatic factors impact, given in section 4

The tested In-Vehicle Emergency Call System/Device sample is considered as having passed the test if after each kind of tests its marking meets the requirements of the section 4 of this regulation.

4.4. The In-Vehicle Emergency Call System/Device performance test under nominal supply voltage.

4.4.3 For the In-Vehicle Emergency Call System/Device performance test it is necessary to prepare a check workTo put with the use of the connection diagram, given in the Figure 2

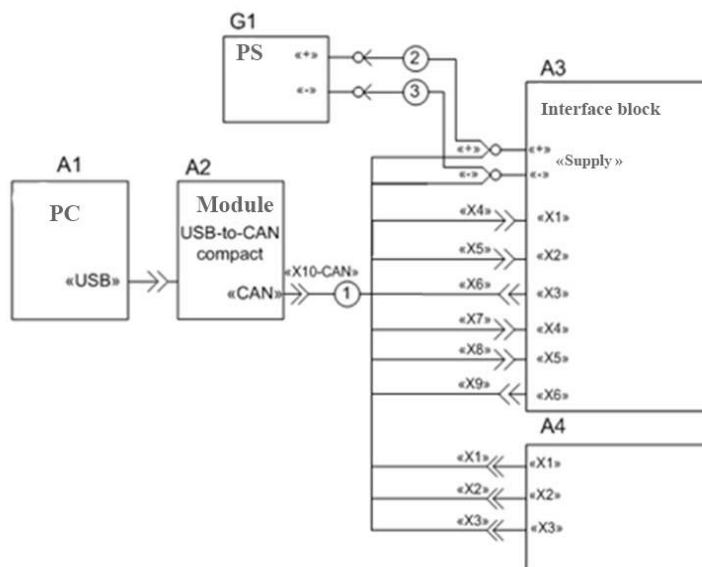

A1 – Personal computer (PC);

A2 – module USB-to-CAN; A3 – interface block;

A4 – tested vehicle system; G1 – power source; 1 – cord;

2,3 – cable ML-4G

Figure 2– The connection diagram for the In-Vehicle Emergency Call System/Device performance test

- to set a test programme (section 2.2.2.) for In-Vehicle Emergency Call System/Device performance test;

- to set an out voltage ($12,0 \pm 0,1$) V or ($24,0 \pm 0,1$) V for the power source G1 – according to a power source system used in a vehicle;
- to plug needed devices into In-Vehicle Emergency Call System/Device according to the connection diagram, given in the Figure 2. All plugged devices must be switched off;
- to run the test programme;
- To enable the power source G1 and a power source of plugged devices, therewith state indicators in the main dialogue box of the test programme should report about the interaction between the interface block and a plugged sample of the In-Vehicle Emergency Call System/Device and the test programme. In case of an error indication occurs it is necessary to disable power supplies and check the validity of devices connection.

4.4.4. The In-Vehicle Emergency Call System/Device performance test is that all tests, available in the test programme, should be consecutively and automatically carried out;

4.4.5 The tested In-Vehicle Emergency Call System/Device is considered as having passed the test if a test programme does not display errors during the test.

4.5 Test for the impact of low ambient temperature.

4.5.1 Test for the In-Vehicle Emergency Call System/Device resistance to the impact of ambient working temperature minus 40°C .

To assemble the diagram for the In-Vehicle Emergency Call System/Device performance test, given in the Figure 2.

To put the In-Vehicle Emergency Call System/Device into cold chamber.

To enable the In-Vehicle Emergency Call System/Device and run the performance test in accordance with section 4.4;

To disable the In-Vehicle Emergency Call System/Device power source.

To lower the temperature in the cold chamber to minus 40°C .

To enable the power source of the In-Vehicle Emergency Call System/Device and run the performance test in accordance with section 4.4;

To keep In-Vehicle Emergency Call Systems/Devices enabled for 3 hours, periodically (every hour) check the tested system performance.

After the last In-Vehicle Emergency Call System/Device performance test (upon expiration of three hours) to disable the power source.

To raise the temperature in the cold chamber to normal (25 ± 10) $^{\circ}\text{C}$ and keep the device in for an hour.

To enable the power source of the In-Vehicle Emergency Call System/Device and run the performance test in accordance with section 4.4;

To take the tested sample from the chamber and to conduct the visual inspection.

The In-Vehicle Emergency Call System/Device is considered to have passed the resistance under low ambient working temperature minus 40°C if there are no any mechanical defects of the In-Vehicle Emergency Call System/Device body (body parts), connectors and connecting cables, as well as during and after the test the In-Vehicle Emergency Call System/Device checks are completed.

4.5.2 The In-Vehicle Emergency Call System/Device test for the durability under the impact of low ambient working temperature minus 40°C .

To assemble the diagram for the In-Vehicle Emergency Call System/Device performance test, given in the Figure 2.

To put the In-Vehicle Emergency Call System/Device into cold chamber.

To enable the In-Vehicle Emergency Call System/Device and run the performance test in accordance with section 4.4;

To disable the In-Vehicle Emergency Call System/Device power source.

To lower the temperature in the cold chamber to minus 40°C and to keep the In-Vehicle Emergency Call System/Device in with power source disabled for three hours.

To raise the temperature in the cold chamber to normal (25 ± 10) °C open the chamber and to keep the device for an hour.

To enable the power source of the In-Vehicle Emergency Call System/Device and run the performance test in accordance with section 4.4;

To take the tested sample from the chamber and to conduct the visual inspection.

The In-Vehicle Emergency Call System/Device is considered to have passed the test for durability under the impact of low ambient working temperature minus 40°C if there are no any mechanical defects on the In-Vehicle Emergency Call System/Device body (body parts), connectors and connecting cables, as well as during and after the test the In-Vehicle Emergency Call System/Device performance checks are completed successfully.

4.5.3 The In-Vehicle Emergency Call System/Device is considered as having passed the test for the impact of low ambient working temperature if the test up to 4.5.1 and 4.5.2 are completed successfully.

4.6 Tests for the impact of high ambient temperature.

4.6.1 Test for the In-Vehicle Emergency Call System/Device resistance to the impact of high ambient working temperature plus 85 °C.

To assemble the diagram for the In-Vehicle Emergency Call System/Device performance test, given in the Figure 2.

To put the In-Vehicle Emergency Call System/Device into heat chamber.

To enable the In-Vehicle Emergency Call System/Device and run the performance test in accordance with the section 4.4;

To disable the In-Vehicle Emergency Call System/Device power source.

To raise the temperature in the heat chamber to plus 85°C.

To enable the power source of the In-Vehicle Emergency Call System/Device and run the performance test in accordance with section 4.4;

To keep the In-Vehicle Emergency Call System/Device enabled for 3 hours, periodically (every hour) check the tested system performance.

After the last In-Vehicle Emergency Call System/Device performance test (upon expiration of three hours) to disable the power source.

To lower the temperature in the heat chamber to normal (25 ± 10) °C and to keep the disabled device in for an hour.

To enable the power source of the In-Vehicle Emergency Call System/Device and run the performance test in accordance with the section 4.4;

To take the tested sample form the chamber and to conduct the visual inspection.

The In-Vehicle Emergency Call System/Device is considered to have passed the resistance test for the impact of high ambient working temperature plus 85°C if there are no any mechanical defects on the In-Vehicle Emergency Call System/Device body (body parts), connectors and connecting cables, as well as during and after the test the performance test has been completed successfully.

4.6.2 The In-Vehicle Emergency Call System/Device test for the durability under the impact of high ambient working temperature plus 85°C.

To assemble the diagram for the In-Vehicle Emergency Call System/Device performance test, given in the Figure 2.

To put the In-Vehicle Emergency Call System/Device into heat chamber.

To enable the In-Vehicle Emergency Call System/Device and run the performance test in accordance with section 4.4;

To disable the In-Vehicle Emergency Call System/Device power source.

To raise the temperature in the heat chamber to 85°C and to keep the In-Vehicle Emergency Call System/Device disabled for three hours.

To reduce the temperature in heat chamber down to 50°C, to keep the In-Vehicle Emergency Call System/Device for 2 hours.

To enable the power source of the In-Vehicle Emergency Call System/Device and run the performance test in accordance with section 4.4;

To disable the power source.

To reduce the temperature in the heat chamber to normal (25 ± 10) °C open the chamber and to keep the device for an hour.

To enable the In-Vehicle Emergency Call System/Device and run the performance test in accordance with section 4.4

To take the tested sample out of the heat chamber and to conduct the visual inspection.

The In-Vehicle Emergency Call System/Device is considered to have passed the test for durability under the impact of high ambient working temperature plus 85°C if there are no any mechanic defects on the In-Vehicle Emergency Call System/Device body (body parts), connectors and connecting cables, as well as during and after the test the performance test has been completed successfully.

4.6.3 The In-Vehicle Emergency Call System/Device is considered to have passed the test for the impact of high ambient working temperature if the tests up to 4.6.1 and 4.6.2 are completed successfully.

4.7 Test for durability when changing the ambient temperature.

4.7.1 During the tests, the In-Vehicle Emergency Call System/Device test for durability under the impact of cycling ambient temperature change in the range of working temperatures:

- from the maximum low - minus 40°C;
- to the maximum high – plus 85°C.

4.7.2 Tests for the impact of temperature cycling change are carried out in the two-section climatic chambers or in the temperature cycling chambers consisting of the cold section (chamber) and heat section (chamber), as well as the device moving the test article from one section to another

Note – It is allowed to carry out tests using separate chambers of heat and cold, but the time of moving the test article from one climatic chamber to another shall not exceed 5 minutes.

4.7.3 During the tests three cycles of temperature change are used. Each cycle consists of two stages. First the test In-Vehicle Emergency Call System/Device sample is put into the cold climatic section (chamber), and then into the heat climatic section (chamber). In each climatic chamber the In-Vehicle Emergency Call System/Device test sample is kept for three hours at maximum working temperature for the appropriate section (chamber) specified in the section 4.7.1.

Time of keeping in the chamber is measured from the moment of reaching in the chamber the desired temperature after the test sample loading.

The time of moving the In-Vehicle Emergency Call System/Device test sample from one climatic section (chamber) to another shall not exceed 5 minutes.

4.7.4 Before test the following is needed to be done:

- To assemble the diagram for the In-Vehicle Emergency Call System/Device performance test, given in the Figure 2.

- To enable the In-Vehicle Emergency Call System/Device and run the performance test according to the section 4.4.

4.7.5 The resistance test of the In-Vehicle Emergency Call System/Device to the changing ambient temperature.

The following ambient parameters should be set in the sections (chambers):

- air temperature – $(25 \pm 10)^{\circ}\text{C}$;
- relative air humidity - from 45% to 80 %;
- bar pressure - from 84,0 to 106,7 kPa (from 630 to 800 mm Hg.).

To put the disabled In-Vehicle Emergency Call System/Device into cold section (chamber).

To lower the section (chamber) temperature to minus 40°C and to keep for three hours.

To move the In-Vehicle Emergency Call System/Device sample to the heat section (chamber).

To raise the section (chamber) temperature to plus 85°C and to keep the In-Vehicle Emergency Call System/Device in for three hours.

To move the In-Vehicle Emergency Call System/Device sample to the cold section (chamber).

Note – The recommended temperature change should be at least:

- $1^{\circ}\text{C}/\text{min}$ - in the range of normal temperature, specified in 4.2, to minus 40°C ;
- $2^{\circ}\text{C}/\text{min}$ - in the range of normal temperature, specified in 4.2, up to 85°C .

4.7.6 The test procedure according to section 4.7.5 should be repeated three times.

4.7.7 After three test cycles to section 4.7.6 to keep the In-Vehicle Emergency Call System/Device sample for 2 hours at ambient temperature, stated in section 4.7.5.

4.7.8 To take the In-Vehicle Emergency Call System/Device from the chamber. To conduct visual inspection and performance test, according to the section 4.4.

4.7.9 The In-Vehicle Emergency Call System/Device is considered as having passed the test for durability under the cyclic change of ambient temperature if there are no any mechanic defects on the In-Vehicle Emergency Call System/Device body (body parts), connectors and connecting cables, as well as during and after the test the performance tests are completed successfully.

4.8 Humidity effect test at a high temperature in a constant mode.

4.8.1 During the tests, the In-Vehicle Emergency Call System/Device compliance test for resistance and durability requirements under the impact of humidity and high ambient temperature.

- relative air humidity – 95%;
- ambient temperature - 40°C ;
- action time- 144 h.

4.8.2 The In-Vehicle Emergency Call System/Device tests for resistance and durability to humidity effect at high ambient temperature.

To put the In-Vehicle Emergency Call System/Device into moisture chamber.

Run the In-Vehicle Emergency Call System/Device performance test using connection diagrams (see Figure 2), according to the section 4.4.

To disable the power source of the In-Vehicle Emergency Call System/Device.

To raise chamber temperature to 40°C at relevant air humidity 95%.

To keep the In-Vehicle Emergency Call System/Device sample in such conditions for 144 h.

Periodically to enable the In-Vehicle Emergency Call System/Device for the performance test, according to the section 4.4.

On completing the third test cycle of tests and upon achieving the specified keeping time to enable the power source of the In-Vehicle Emergency Call System/Device and run the performance test, according to the test method stated in the operational documentation, after which to disable the power source.

To take the In-Vehicle Emergency Call System/Device from the humidity chamber; to keep at normal climatic conditions stated in 4.7.5 for at least 2 hours, run the sample test according to the section 4.7.5, check the sample performance according to the section 4.4.

4.8.3 On completing the tests, to assess the corrosive damage of device units. There should be no serious corrosive damage, which can interfere with a correct work of the In-Vehicle Emergency Call System/Device.

4.8.4 The In-Vehicle Emergency Call System/Device sample is considered as having passed the test if there is no serious corrosive damage and all performance tests are successfully completed.

4.9 Test for the impact of dust for the degree of protection according to IEC 529:1989.

4.9.1 Dust test is carried out to check the requirements for the degree of protection of the In-Vehicle Emergency Call System/Device against the intrusion of foreign objects as defined by the first digit of IP Code according to IEC 529:1989.

4.9.2 For all In-Vehicle Emergency Call System/Device components manufactured in box type the degree of protection against the intrusion of foreign objects should not be less than IP52.

4.9.3 The composition of the test equipment, its characteristics and the main testing conditions according to degrees of protection of the In-Vehicle Emergency Call System/Device provided in 4.9.2 – in compliance with IEC 529:1989 (subsection 14.2 and table 8).

4.9.4 Before running the test to conduct the visual inspection of all In-Vehicle Emergency Call System/Device units (blocks) and run the performance test according to the section 4.4.

4.9.5 To put the disabled In-Vehicle Emergency Call System/Device into dust chamber so that the distance between blocks and walls of chamber and nearby blocks (in case of simultaneous testing of several blocks) is not less than 10 cm.

4.9.6 Tests are carried out according to IEC 529:1989 (section 13.4) without pressure reduction inside tested In-Vehicle Emergency Call System/Device units in comparence to environment (covers 2 after IEC 529:1989) in the medium of non-conducting abrasive dust under the following conditions:

- ambient air temperature (35 ± 2) °C;
- relevant air humidity not more than 60 %;
- dust concentration in the air ($1, 4 \pm 1$) g/m³ (or 0,1 % from effective chamber volume);
- speed of air circulation from 10 to 15 m/sec.

4.9.7 On completing the tests to keep the In-Vehicle Emergency Call System/Device in the chamber for one hour for dust deposition without air circulation. After which to take the In-Vehicle Emergency Call System/Device out of the chamber, to remove dust remains and to conduct the visual inspection. The lacquer coating of the In-Vehicle Emergency Call System/Device should not be damaged.

To run the performance test of the In-Vehicle Emergency Call System/Device according to the section 4.4.

4.9.8 Assessment of the test results for the In-Vehicle Emergency Call System/Device blocks with the degree of protection IP52 after IEC 529:1989

Blocks (component units) of the In-Vehicle Emergency Call System/Device are considered to have passed the test if:

- damage of lacquer coating is not observed after the test;
- after the opening of the test In-Vehicle Emergency Call System/Device units of the inside body surfaces and circuit boards there are small amounts of dust in the form of thin coating of dust;
- all performance tests of the In-Vehicle Emergency Call System/Device carried out in accordance with 4.9.7 are successfully completed.

4.10 Tests for the impact of water to assess the degree of protection according to IEC 529:1989

4.10.1 Test for the impact of water is carried out to check the requirements for the degree of protection of the In-Vehicle Emergency Call System/Device against the intrusion of foreign objects as defined by the first digit of IP Code according to IEC 529:1989.

4.10.2 For all In-Vehicle Emergency Call System/Device units manufactured in box types the degree of protection against the intrusion of foreign objects should not be less than IP52.

4.10.3 The composition of the test equipment, its characteristics and the main testing conditions according to degrees of protection of In-Vehicle Emergency Call System/Device provided in 4.10.2 – in compliance with IEC 529:1989 (subsection 14.2 and table 8).

4.10.4 Before running the test to conduct the visual inspection of all In-Vehicle Emergency Call System/Device units (blocks) and run the performance test according to the section 4.4.

4.10.5 Tests for the impact of water are carried out with the disabled In-Vehicle Emergency Call System/Device.

4.10.6 Test for the impact of water for degree of protection is carried out after IEC 529:1989 (subsection 14.2.2);

4.10.7 On completing the tests run the performance test of the In-Vehicle Emergency Call System/Device according to the section 4.4. Then to open the In-Vehicle Emergency Call System/Device blocks and to inspect water penetration inside.

Note - During the tests moisture contained within the IVS test units shell may partially condense. Accumulated condensation should not be confused with the water seeping into the shell from outside during the test.

4.10.8 Blocks (component units) of the In-Vehicle Emergency Call System/Device are considered to have passed the test if the amount of water penetrated into the shell from outside did not lead to the In-Vehicle Emergency Call System/Device malfunction.

Note – If in the design of the In-Vehicle Emergency Call System/Device individual units (components) there are drains provided by the manufacturer and recorded in the Operational Documentation, it is necessary to make sure by inspection, that the penetrating water does not accumulate inside and can freely to go through these holes without disturbing operability of these In-Vehicle Emergency Call System/Device units (components).]

[Annex 6 - Appendix A

Minimum data set

1. Data presentation

1.1 The minimum data set should be presented in an abstract syntactic notation one in compliance with IEC 8824-1 and IEC 8825-2 with the use of packed encoding without ragged margin.

The location of separate data elements in a general data structure is defined in compliance with IEC 8824-1 and ISO/IEC 8825 taking into account the information given in the section 3.

1.2 Data sequence should conform to requirements stated in the section 2.

2. Minimum data set

2.1 The sequence of bits and bytes should conform the sequence stated in IEC 8824-1.

2.2 The content of minimum data set is given in table 1.

Table 1 – The content of minimum data set with standard data.

Data block number	Data block name	Data block type	Unit measure	Status	Data block description
1	ID	Integer	-	M	Minimum Data Set format version is set in “1”. The following versions should be compatible with the previous ones. Systems receiving Minimum Data Set should sustain all standardized Minimum Data Set versions.
2	Message Identifier	Integer	-	M	Message descriptor begins with “1” for every new session of an emergency call and should increment with every following Minimum Data Set sending.
3	Control	Bit sequence	-	M	<p>AutomaticActivation (automatic activation):</p> <ul style="list-style-type: none"> - True – automatic activation; - False – manual activation. <p>TestCall type (test call):</p> <ul style="list-style-type: none"> - True – test call; - False – emergency call. <p>PositionCanBeTrusted (reliable determination of location):</p> <ul style="list-style-type: none"> - True – reliable determination of location; - False – uncertain determination of location. <p>The method of vehicle encoding is specified in C.3.</p>

Table 1 continuation

Data block number	Data block name	Data block type	Unit measure	Status	Data block description
					<p>The list of the supported categories of vehicles:</p> <ul style="list-style-type: none"> - passenger (category M1); - buses (category M2); - buses (category M3); - light trucks (category N1); - trucks (category N2); - trucks (category N3); - motorbikes (category L1e); - motorbikes (category L2e); - motorbikes (category L3e); - motorbikes (category L4e); - motorbikes (category L5e); - motorbikes (category L6e); - motorbikes (category L7e). <p>Parameter PositionCanBeTrusted is set to FALSE value, if vehicle location data is not changed with the accuracy 150 meters and certainty value 95%</p>
4	Vehicle identification	String	-	M	VIN code of the vehicle

Table 1 continuation

Data block number	Data block name	Data block type	Unit measure	Status	Data block description
5	Vehicle propulsion storage type	Integer	-	M	<p>Vehicle fuel type (energy source). For each fuel type (energy source) the following encoding is applicable:</p> <ul style="list-style-type: none"> - False – the given fuel type (energy source) is not presented; - True - the given fuel type (energy source) is presented. <p>Following fuel types can be supported (energy source):</p> <ul style="list-style-type: none"> - gasoline; - diesel fuel; - compressed gas; - liquefied gas propane; - electro energy storage (more than 42 V and 100 A/hour); - hydrogen storage. <p>All bits should be set in “0” for the indication of the unknown or unsupported fuel type (energy source).</p> <p>More than one bit can be set in case if several fuel types are used in a vehicle (energy source).</p>
6	Time stamp	Integer	UTC, s	M	<p>The time mark of the road accident - number in seconds, UTC which have passed since January 01, 1970. If there was an error in case of road accident time determination then the value should be set in “0”.</p>

Table 1 continuation

Data block number	Data block name	Data block type	Unit measure	Status	Data block description
7	Vehicle Location	Integer	Second of angle, ..."	M	Latitude ¹⁾ . If latitude is unknown or there is an error in latitude determination, then the value should be set in "0x7FFFFFFF"
		Integer	Second of angle, ..."	M	Longitude ²⁾ . If longitude is unknown or there is an error in longitude determination, then the value should be set in "0x7FFFFFFF"
8	Vehicle direction	Integer	Degrees	M	Vehicle direction (course), digitized from the direction on a magnetic pole clockwise with discretization in 2 ° (from 0 ° to 358 °). If the direction of movement isn't known or if there was an error in case of movement direction finding, this value needs to be set in 0x7F.
9	Recent vehicle location n-1	Integer	³⁾	O	Deviation on latitude ("plus" – for the direction to the north and "minus" – for the direction to the south) in relation to a parameter value of the current location of the vehicle defined in a data unit number 7 ³⁾ .
		Integer	⁴⁾	O	Deviation on longitude ("plus" – for the direction to the east and "minus" – for the direction to the west) in relation to a parameter value of the current location of the vehicle defined in a data unit number 7 ⁴⁾ .
10	Recent vehicle location n-2	Integer	³⁾	O	Deviation on latitude ("plus" – for the direction to the north and "minus" – for the direction to the south) in relation to Recent vehicle location n-1, defined in a data unit number 9 ³⁾ .
		Integer	⁴⁾	O	Deviation on longitude ("plus" – for the direction to the east and "minus" – for the direction to the west) in relation to a parameter value Recent vehicle location n-1, defined in a data unit number 9 ⁴⁾ .
11	Number of passengers	Integer	-	O	The smallest known number of the fastened seat belts. This parameter can be set in "0" or isn't provided if information on number of the fastened seat belts is absent.

The end of table 1

Data block number	Data block name	Data block type	Unit measure	Status	Data block description
12	Optional additional data	String	-	O	Following 103 bytes are encoded in accordance with GOST R ISO/ IEC 8824-1.
<p>1) Value of location latitude of a vehicle determined by the navigation receiver and expressed according to requirements of section 8 in the NMEA-0183 [5] format in degrees, minutes and shares of minute, in case of Minimum Data Set is included is enumerated in angular milliseconds and expresses in hexadecimal number system. The value range expressed in angular milliseconds: from a minus 324000000 to plus 324000000. The greatest value: $90^{\circ}00'00,000'' = 90 \cdot 60 \cdot 60,000'' = 324000,000'' = 324\,000\,000$ angular milliseconds = 0x134FD900. The smallest value: $\text{minus } 90^{\circ}00'00,000'' = \text{minus } 90 \cdot 60 \cdot 60,000'' = \text{minus } 324000,000'' = \text{minus of } 324\,000\,000$ angular milliseconds = 0xECB02700. Example: $48^{\circ}18'1.20''$; $N = \{(48 \cdot 3600) + (18 \cdot 60) + 1.20\}'' = 173881,200'' = 173881200 = 0x0A5D3770$.</p> <p>2) Value of location latitude of a vehicle determined by the navigation receiver and expressed according to requirements of section 8 in the NMEA-0183 [5] format in degrees, minutes and shares of minute, in case of Minimum Data Set is included is enumerated in angular milliseconds and expresses in hexadecimal number system. The value range expressed in angular milliseconds: from a minus 648000000 to plus 648000000. The greatest value: $180^{\circ}00'00,000'' = 180 \cdot 60 \cdot 60,000'' = 648000,000'' = 648\,000\,000$ angular milliseconds = 0x269FB200. The smallest value: $\text{minus } 180^{\circ}00'00,000'' = \text{minus } 180 \cdot 60 \cdot 60,000'' = \text{minus } 648000,000'' = \text{minus of } 648\,000\,000$ angular milliseconds = 0xD9604E00. Example: $11^{\circ}37'2.52''$; $E = \{(11 \cdot 3600) + (37 \cdot 60) + 2.52\}'' = 41822,520'' = 41822520 = 0x027E2938$.</p> <p>3) Is expressed in conventional units, 1 unit = 0,1 " that corresponds, approximately, 3 m. Value range: from minus 512 to plus 511 or from minus 51,2"S to plus 51,1"N from the current location.</p> <p>4) Is expressed in conventional units, 1 unit = 0,1 " that corresponds, approximately, 3 m. Value range: from minus 512 to plus 511 or from minus 51,2"W to plus 51,1"E from the current location.</p> <p>Note – in the graph "Status" the following designations are used: - M (mandatory) – obligatory parameter. It shall be transferred always; - O (optional) – non-obligatory parameter. It may not be transferred and its presence is defined by other parameters entering into a packet.</p>					

3. Abstract syntactic notation.1 Minimum data set presentation with standardised data (packed encoding)

MSDASN1Module

DEFINITIONS

AUTOMATIC TAGS ::=

BEGIN

-- specification version of Minimum data set

CurrentId ::= INTEGER (1)

-- ECallMessage is an information item of the top level

-- The structure of ECallMessage supports only one message type (msd)

-- Extension at this level isn't authorized for support

-- Possibilities of direct extraction of an ID (data format version).

-- Elements:

-- id: the Minimum data set is set in 1

-- msd: Minimum data set, transferred from the VS excluding ID

ECallMessage ::= SEQUENCE {

id INTEGER(0 .. 255),

msd MSDMessage

}

-- The message transferred from the VS (excluding ID)

-- Elements:

-- msdStructure: Main structure of Minimum data set

-- optionalAdditionalData: Additional data

-- It is expanded in upcoming versions at this level

MSDMessage ::= SEQUENCE {

msdStructure MSDStructure,

optionalAdditionalData AdditionalData OPTIONAL,

...

}

-- Main structure of Minimum data set, excluding additional

-- Elements:

-- messageIdentifier: Message Identifier

-- control: see ControlType

-- vehicleIdentificationNumber: see VIN

-- vehiclePropulsionStorageType: see VehiclePropulsionStorageType

-- timestamp: time mark

-- vehicleLocation: see VehicleLocation

-- vehicleDirection: Vehicle direction

-- recentVehicleLocationN1: deviation from the current location

-- see VehicleLocationDelta

-- recentVehicleLocationN2: deviation from the recentVehicleLocationN1

```

-- see VehicleLocationDelta
-- numberOfPassengers: minimum known quantity or fastened seat belts
MSDStructure ::= SEQUENCE {
    messageIdentifier INTEGER(0 .. 255),
    control ControlType,
    vehicleIdentificationNumber VIN,
    vehiclePropulsionStorageType VehiclePropulsionStorageType,
    timestamp INTEGER(0 .. 4294967295),
    vehicleLocation VehicleLocation,
    vehicleDirection INTEGER(0 .. 255),
    recentVehicleLocationN1 VehicleLocationDelta OPTIONAL,
    recentVehicleLocationN2 VehicleLocationDelta OPTIONAL,
    numberOfPassengers INTEGER(0 .. 255) OPTIONAL,
    ...
}
-- ControlType consists of the following elements:
-- automaticActivation: true, false
-- testCall: true, false
-- positionCanBeTrusted: true, false
-- vehicleType: cm. VehicleType
ControlType ::= SEQUENCE {
    automaticActivation BOOLEAN,
    testCall BOOLEAN,
    positionCanBeTrusted BOOLEAN,
    vehicleType VehicleType
}
-- Identification of vehicle type
VehicleType ::= ENUMERATED{
    passengerVehicleClassM1 (1),
    busesAndCoachesClassM2 (2),
    busesAndCoachesClassM3 (3),
    lightCommercialVehiclesClassN1 (4),
    heavyDutyVehiclesClassN2 (5),
    heavyDutyVehiclesClassN3 (6),
    motorcyclesClassL1e (7),
    motorcyclesClassL2e (8),
    motorcyclesClassL3e (9),
    motorcyclesClassL4e (10),
    motorcyclesClassL5e (11),
    motorcyclesClassL6e (12),
    motorcyclesClassL7e (13),
    ...
}

```

```

}
-- VIN
VIN ::= SEQUENCE {
    isowmi PrintableString (SIZE(3))
    (FROM(«A»..»H»|»J»..»N»|»P»|»R»..»Z»|»0»..»9»)),
    isovds PrintableString (SIZE(6))
    (FROM(«A»..»H»|»J»..»N»|»P»|»R»..»Z»|»0»..»9»)),
    isovisModelyear PrintableString (SIZE(1))
    (FROM(«A»..»H»|»J»..»N»|»P»|»R»..»Z»|»0»..»9»)),
    isovisSeqPlant PrintableString (SIZE(7))
    (FROM(«A»..»H»|»J»..»N»|»P»|»R»..»Z»|»0»..»9»))
}
-- VehiclePropulsionStorageType:
-- Fuel type (energy source) of the vehicle
VehiclePropulsionStorageType ::= SEQUENCE {
    gasolineTankPresent BOOLEAN DEFAULT FALSE,
    dieselTankPresent BOOLEAN DEFAULT FALSE,
    compressedNaturalGas BOOLEAN DEFAULT FALSE,
    liquidPropaneGas BOOLEAN DEFAULT FALSE,
    electricEnergyStorage BOOLEAN DEFAULT FALSE,
    hydrogenStorage BOOLEAN DEFAULT FALSE,
    ...}
-- VehicleLocation:
-- Current location of the vehicle
-- Elements:
-- Latitude - 32 bits (4 octets) are assigned
-- Longitude - 32 bits (4 octets) are assigned
VehicleLocation ::= SEQUENCE {
    positionLatitude INTEGER(-2147483648..2147483647),
    positionLongitude INTEGER(-2147483648..2147483647)
}
-- VehicleLocationDelta:
-- Vehicle location before the road accident identification
VehicleLocationDelta ::= SEQUENCE {
    latitudeDelta INTEGER (-512..511),
    longitudeDelta INTEGER (-512..511)
}
-- AdditionalData:
-- Additional data, encoded as a separate definition
-- Elements:
-- oid: Identifier of the object, which defines a format and assignment of data
-- data: additional data in accordance with the format, oid defined

```

```
AdditionalData ::= SEQUENCE {  
    oid RELATIVE-OID,  
    data OCTET STRING  
}  
END
```

4. The scope of additional data of Minimum data set (the assessment of the road accident greatness)

4.1 Additional data included in the Minimum data set, shall locate in the data block number 12 - optional additional data.

4.2 The scope of the data block number 12 for the presentation of the assessment of the road accident greatness is given in table 2.

Table 2 – The scope of the data block number 12 for the presentation of the assessment of the road accident

Data block number	Data block name	Data block type	Unit measure	Status	Data block description
12-A0	OID	Integer	1 byte	M	Additional data block identifier, including parameters additionally entered for the Global Navigation Satellite System, Road Accident Emergency Response System – is set in value11000000.
12-A1	ID	Integer	1 byte	M	The format version of additional data of the Minimum data set is set in “1”. The upcoming versions shall be compatible with the previous ones.
12-A2	SevereCrash Estimation	BOOLEAN	–	M	SevereCrashEstimation: - TRUE – essential probability of life threat and human health, being in a vehicle cabin; - FALSE – non-essential probability of life threat and human health, being in a vehicle cabin; .
	TestResultsDef	Bit sequence	–	O	The method of encoding is specified in C.5. The list of errors types: - incorrect microphone connection; - microphone disability; - malfunction of the right loudspeaker; - malfunction of the left loudspeaker; - malfunction of loudspeakers; - malfunction at defining a condition of the ignition line; - неисправность БИП; - malfunction of status identifier; - malfunction of standby battery; - discharge of standby battery is below admissible level; - failure of the sensor of automatic identification of road accident; - violation of integrity of an image of the software; - nonserviceability of the interface of the communication GSM and UMTS module; - nonserviceability of the Global Navigation Satellite System receiver; - violation of integrity (reliability) of navigation and temporal parameters determined by the Global Navigation Satellite System receiver (RAIM function); - nonserviceability (incorrect connection) of external Global Navigation Satellite System antenna ; - nonserviceability (incorrect connection) of external GSM and UMTS antenna; - overflowing of an internal memory of events; - overflowing of memory for record of acceleration profiles; -other critical errors.

Data block number	Data block name	Data block type	Unit measure	Status	Data block description
	MobileDef	Integer	15 byte	O	The method of encoding is specified in C.5. The block consists of 6 parametres: eraMCC –MCC Network code (0 if not defined); eraMNCSID – MNC / SID code (0 if not defined); eraLACNID – LAC/NID eraCIDBID – Cell ID/Base Station ID (0 if not defined); eraSector – sector number (0 if not defined); eraRSSI – the level of received signal (minus 150, if not defined).
	CrashDef	Последовательность бит		O	The method of encoding is specified in C.5. The list of road accidents types is bellow: crashFront – front crash; crashSide – side crash; crashFrontOrSide – front or side crash; crashRear – rear crash; crashRollover – rollover; crashAnotherType – another type of crash;

5. Abstract syntactic notation.1 Additional data presentation (the assessment of the road accident greatness) (packed encoding)

```
OptionalAdditionalData ::= SEQUENCE {  
    oid BIT STRING (SIZE(8)),  
    id BIT STRING (SIZE(8)),  
    SevereCrashEstimation BOOLEAN (SIZE(1)),  
    MobileDef MobileType OPTIONAL,  
    TestResultsDef TestResultsType OPTIONAL,  
    CrashDef CrashType OPTIONAL  
}
```

```
TestResultsType ::= SEQUENCE {  
    micConnectionFailure BOOLEAN DEFAULT FALSE,  
    micFailure BOOLEAN DEFAULT FALSE,  
    rightSpeakerFailure BOOLEAN DEFAULT FALSE,  
    leftSpeakerFailure BOOLEAN DEFAULT FALSE,  
    speakersFailure BOOLEAN DEFAULT FALSE,  
    ignitionLineFailure BOOLEAN DEFAULT FALSE,  
    uimFailure BOOLEAN DEFAULT FALSE,  
    statusIndicatorFailure BOOLEAN DEFAULT FALSE,  
    batteryFailure BOOLEAN DEFAULT FALSE,  
    batteryVoltageLow BOOLEAN DEFAULT FALSE,  
    crashSensorFailure BOOLEAN DEFAULT FALSE,  
    swImageCorruption BOOLEAN DEFAULT FALSE,  
    commModuleInterfaceFailure BOOLEAN DEFAULT FALSE,  
    gnssReceiverFailure BOOLEAN DEFAULT FALSE,  
    raimProblem BOOLEAN DEFAULT FALSE,
```

```
gnssAntennaFailure BOOLEAN DEFAULT FALSE,  
commModuleFailure BOOLEAN DEFAULT FALSE,  
eventsMemoryOverflow BOOLEAN DEFAULT FALSE,  
crashProfileMemory overflow BOOLEAN DEFAULT FALSE,  
otherCriticalFailires BOOLEAN DEFAULT FALSE,  
otherNotCriticalFailures BOOLEAN DEFAULT FALSE  
}
```

```
MobileType ::= SEQUENCE {  
    eraMCC INTEGER (0 .. 999),  
    eraMNCSID INTEGER (0 .. 99, ..., 100..16383),  
    eraLACNID INTEGER (0 .. 65535),  
    eraCIDBID INTEGER (0 .. 65535),  
    eraSector INTEGER (0 .. 15, ..., 16..255),  
    eraRSSI INTEGER (-150 ... 0)  
}
```

```
CrashType ::= SEQUENCE {  
    crashFront BOOLEAN DEFAULT FALSE,  
    crashSide BOOLEAN DEFAULT FALSE,  
    crashFrontOrSide BOOLEAN DEFAULT FALSE,  
  
    crashRear BOOLEAN DEFAULT FALSE,  
    crashRollover BOOLEAN DEFAULT FALSE,  
    crashAnotherType BOOLEAN DEFAULT FALSE
```

```
}}
```

[Annex 7

Test methods for resistance to mechanical impact

1. Definitions

Definitions for the purposes of this Annex are given in section 1 Annex 6.

2. Test conditions

2.1 Compliance test for mechanical resistance requirements for In-vehicle Emergency Call System/Device includes the tests for durability and stability to the mechanical factors impact.

2.2 The tests for Mechanical Resistance Requirements for In-vehicle Emergency Call System/Device are carried out under normal climatic conditions:

- ambient air temperature – $(25 \pm 10)^{\circ}\text{C}$;
- relative air humidity - from 45% to 80 %;
- bar pressure - from 84,0 to 106,7 kPa (from 630 to 800 mm Hg.).

In-vehicle Emergency Call System/Device components which are not in similar operating conditions are tested separately in accordance with the operating conditions established for each of them. It is allowed to test the In-vehicle Emergency Call System/Device in a full set under the most stringent standards of testing regimes.

Servicing of the In-vehicle Emergency Call System/Device is not conducted during the test.

2.3 The test In-vehicle Emergency Call System/Device samples or its component parts must be attached to the test stand platform by one of the following ways simulating the operating conditions:

- directly on the stand platform;
- by a mounting fixture;
- by its own dampers (if any).

3. Test equipment

3.1 The composition of the test and auxiliary equipment used in the tests is listed in table 1.

Table 1 Test equipment

Equipment name	The required technical characteristics of the devices and equipment
Vibration stand	Frequency range — from 10 to 100 Hz; maximum amplitude of acceleration - not less than 98 m/s ² (10 g); acceleration amplitude accuracy - not more than ± 2 m/s ² (0.2 g)
Shock plant of repeated action	Shock impulse duration - not less than 5 ms; shocks per minute — from 40 to 80; peak shock acceleration — from 49 m/s (5g) to 250 m/s (25g).
Shock plant	Single shocks; peak shock acceleration – to 100 g
Stand of the In-vehicle Emergency Call System/Device debugging and control	Picture 1 Annex 6

4. Test Procedure

4.1 In-vehicle Emergency Call System/Device marking check

In-vehicle Emergency Call System/Device marking compliance check is carried out after each kind of system tests for mechanical factors impact from among the ones listed in section 4.

The tested In-vehicle Emergency Call System/Device sample is considered to have passed the test if after each kind of tests listed in section 4 its marking meets the requirements of section 4 of the body text of this Regulation.

4.2 Resistance test when exposed to sinusoidal vibration

4.2.1 The test is performed in three mutually perpendicular positions

4.2.2 To conduct the visual inspection and to attach the test In-vehicle Emergency Call System/Device sample on the vibrostand platform in one of three mutually perpendicular positions.

4.2.3 Using the connection diagrams (see picture 2 Annex 6), test the system operability according to the test method given in section 4.4 Annex 6

To expose the turned on In-vehicle Emergency Call System/Device to the impact of vibration with the following values of influencing factors:

- frequency range, Hz – (from 10 to 70).
- acceleration amplitude, m/s – 39.2 (4 g).
- duration of exposure, min – 30.

To change the frequency of vibration in the specified range gradually in order to detect the construction resonances.

During the test to check the In-vehicle Emergency Call System/Device operability periodically according to the test method given in section 4.4 Annex 6.

In-vehicle Emergency Call System/Device must be workable and error messages shall not be displayed.

4.2.4 On the expiry of the set test time to test the In-vehicle Emergency Call System/Device operability according to the test method given in section 4.4 Annex 6.

To turn off the In-vehicle Emergency Call System/Device power supply.

4.2.5 To change the v position on the vibrostand and to repeat the actions according to 4.2.3 and 4.2.4 for the other two mutually perpendicular positions.

4.2.6 The v is considered to have passed the resistance test under the impact of sinusoidal vibration if there are no mechanical defects of the v body (body parts), connectors and connecting cables, as well as during and after the test, the In-vehicle Emergency Call System/Device operability checks are completed successfully.

4.3 Durability test when exposed to sinusoidal vibration

4.3.1 The test is performed in three mutually perpendicular positions.

4.3.2 To conduct the visual inspection and to attach the test v sample on the vibrostand platform in one of three mutually perpendicular positions.

4.3.3 Using the connection diagrams (see picture 2 Annex 6), test the system operability according to the test method given in section 4.4 Annex 6

4.3.4 Vibration durability test is conducted with the turned off power source and the following values of influencing factors:

- frequency range, Hz – (10 to 70);
- acceleration amplitude, m/s – 49 (4 g);
- duration of exposure, min – 2 h 40 min.

During the tests to change periodically the vibration frequency from the upper to the lower limits of the frequency range.

4.3.5 To take the In-vehicle Emergency Call System/Device down from the vibrostand, to conduct the visual inspection and operability check according to the test method given in section 4.4 Annex 6

4.3.6 To change the v position on the vibrostand and to repeat the actions according to 4.3.4 and 4.3.5 for the other two mutually perpendicular positions.

4.3.7 The In-vehicle Emergency Call System/Device is considered to have passed the durability test under the impact of sinusoidal vibration if there are no mechanical defects of the In-vehicle Emergency Call System/Device body (body parts), connectors and connecting cables, and the In-vehicle Emergency Call System/Device operability check is completed successfully.

4.4 Stability test when exposed to mechanical shocks of repeated action

4.4.1 Stability test when exposed to mechanical shocks of repeated action is conducted with the In-vehicle Emergency Call System/Device turned on.

In-vehicle Emergency Call System/Device is exposed to shocks in each of three mutually perpendicular positions with the following values of influencing factors:

- peak shock acceleration – 98 m/s² (10 g);
- shock repetition frequency – no more than 80 shocks/min;
- shock duration – from 5 to 15 ms (preferably – 10 ms);

- the number of shocks in each direction – 333 (overall number of shocks – 1000).

4.4.2 To conduct the visual inspection and to attach the test In-vehicle Emergency Call System/Device sample on the platform of the mechanical shock plant in one of three mutually perpendicular positions.

4.4.3 Using the connection diagrams (see picture 2 Annex 6), to test the In-vehicle Emergency Call System/Device operability according to the test method given in section 4.4 Annex 6

4.4.4 To expose the In-vehicle Emergency Call System/Device to the impact of mechanical shocks with the parameters set out in 4.4.1

4.4.5 During the test to check the In-vehicle Emergency Call System/Device operability periodically according to the test method given in section 4.4 Annex 6 In-vehicle Emergency Call System/Device must be workable and error messages shall not be displayed.

4.4.6 After the test completion to check the v In-vehicle Emergency Call System/Device operability according to the test method given in section 4.4 Annex 6

To turn off the In-vehicle Emergency Call System/Device power supply.

4.4.7 To change the In-vehicle Emergency Call System/Device position on the mechanical shock plant and to repeat the actions according to 4.4.3 – 4.4.5 for the other two mutually perpendicular positions.

4.4.8 To take the In-vehicle Emergency Call System/Device down from the mechanical shock plant, to conduct the visual inspection and operability check according to the test method given in section 4.4 Annex 6

4.4.9 The In-vehicle Emergency Call System/Device is considered to have passed the stability test when exposed to mechanical shocks of repeated action if there are no mechanical defects, damage of paint-and-lacquer coating, looseness of the In-vehicle Emergency Call System/Device components attachments, and the In-vehicle Emergency Call System/Device operability tests are completed successfully.

4.5 In-vehicle Emergency Call System/Device durability test when exposed to mechanical shocks of repeated action

4.5.1 The test is performed in three mutually perpendicular positions In-vehicle Emergency Call System/Device

4.5.2 To conduct the visual inspection and to attach the test In-vehicle Emergency Call System/Device sample on the platform of the mechanical shock plant in one of three mutually perpendicular positions.

4.5.3 Using the connection diagrams (see picture 2 Annex 6), test the system operability according to the test method given in section 4.4 Annex 6.

4.5.4 In-vehicle Emergency Call System/Device durability test when exposed to mechanical shocks of repeated action is conducted with the In-vehicle Emergency Call System/Device turned off with the following values of influencing factors:

- peak shock acceleration – 98 m/s² (10 g);
- shock repetition frequency – no more than 80 shocks/min;
- shock duration – from 5 to 15 ms (preferably – 10 ms);
- the number of shocks in each direction – 333 (overall number of shocks – 1000).

4.5.5 To take the In-vehicle Emergency Call System/Device check according to the test method given in section 4.4 Annex 6.

4.5.6 To change the In-vehicle Emergency Call System/Device position on the mechanical shock plant and to repeat the actions according to 4.5.3 – 4.5.5 for the other two mutually perpendicular positions.

4.5.7 The In-vehicle Emergency Call System/Device is considered to have passed the durability test when exposed to mechanical shocks of repeated action if there are no mechanical defects, damage of paint-and-lacquer coating, looseness of the In-vehicle Emergency Call System/Device components attachments, and the In-vehicle Emergency Call System/Device operability tests are completed successfully.

4.6 Test of In-vehicle Emergency Call System/Device resistance to single mechanical shocks with acceleration 75 g

4.6.1 To conduct the visual inspection and to attach the test In-vehicle Emergency Call System/Device sample on the platform of the mechanical shock plant in a special a special device that simulates the conditions attachment on a vehicle

4.6.2 Using the connection diagrams (see picture 2 Annex 6), to test the In-vehicle Emergency Call System/Device operability according to the test method given in section 4.4 Annex 6.

4.6.3 To expose the In-vehicle Emergency Call System/Device to the impact of three single mechanical shocks with the peak shock acceleration 735 m/s² (75g) and the shock acceleration duration from 1 to 5 ms (preferably 3 ms).

4.6.4 To take the In-vehicle Emergency Call System/Device down from the mechanical shock plant, to conduct the visual inspection of the attachment and operability check according to the test method for acceleration sensors.

4.6.5 The In-vehicle Emergency Call System/Device is considered to have passed the test of In-vehicle Emergency Call System/Device resistance to single mechanical shocks with acceleration 75 g if there are no mechanical defects, damage of paint-and-lacquer coating, looseness of the In-vehicle Emergency Call System/Device components attachments, and the In-vehicle Emergency Call System/Device operability tests are completed successfully.

4.7 Test of In-vehicle Emergency Call System/Device resistance to mechanical shocks during transportation

4.7.1 The tests are conducted in order to check the v compliance to requirements of for resistance to mechanical shocks during packaged transportation. The In-vehicle Emergency Call System/Device must be workable and does not have mechanical defects and damage after vibration and mechanical shocks.

Table 12 – Vibration and shock stress

Assessed feature of the In-vehicle Emergency Call System/Device	Test parametres	Influencing factor	
		Value	Permitted deviation
Resistance test when exposed to sinusoidal vibration	Range of frequencies, Hz	10-70	±1
	Acceleration amplitude, m/s ² (g)	39,2 (4)	±2(0,2)
	Action time in each of three directions, min	30	-
Durability test when exposed to sinusoidal vibration	Range of frequencies, Hz	50	±1
	Acceleration amplitude, m/s ² (g)	49 (5)	±2 (0,2)
	Action time in each of three	2 h 40 min	-

Assessed feature of the In-vehicle Emergency Call System/Device	Test parametres	Influencing factor	
		Value	Permitted deviation
	directions, min		
Stability test when exposed to mechanical shocks of repeated action	Shock acceleration peak value, m/s ² (g)	98 (10)	±20%
	Shock duration, ms	10	-
	Sweep count in each of three directions	333	-
In-vehicle Emergency Call System/Device durability test when exposed to mechanical shocks of repeated action	Shock acceleration peak value, m/s ² (g)	98 (10)	±20%
	Shock duration, ms	10	-
	Sweep count in each of three directions	3333	-
Test of In-vehicle Emergency Call System/Device resistance to mechanical shocks during transportation	Shock acceleration peak value, m/s ² (g)	250 (25)	±20%
	Shock duration, ms	6	-
	Sweep count in each of three directions	4000	-
Test of In-vehicle Emergency Call System/Device resistance to single mechanical shocks with acceleration 75 g	Single shock, g	75	-
	Shock duration, ms	1-5	-

4.7.2 The test is performed in three mutually perpendicular positions In-vehicle Emergency Call System/Device.

4.7.3 To conduct the visual inspection and to attach the test In-vehicle Emergency Call System/Device sample in package on the platform of the mechanical shock plant.

To expose the In-vehicle Emergency Call System/Device to the impact of mechanical shocks in each of three mutually perpendicular In-vehicle Emergency Call System/Device positions with the peak shock acceleration 250 m/s² (25g) and the shock acceleration duration from 5 to 10 ms (preferably 6 ms). Shocks number in each of three positions – 4000, shocks repetition frequency – not more than 80 shocks per minute.

4.7.4 To take the packaged In-vehicle Emergency Call System/Device down from the mechanical shock plant, to conduct the visual inspection of the package. It shall not be damaged.

4.7.5 To take out from the package and to conduct the visual In-vehicle Emergency Call System/Device inspection. Bodies and In-vehicle Emergency Call System/Device external connectors must not be damaged.

4.7.6 To test the In-vehicle Emergency Call System/Device operability according to the test method given in section 4.4 Annex 6.

4.7.7 The In-vehicle Emergency Call System/Device is considered to have passed the test of v resistance to mechanical shocks during transportation if there are no mechanical defects on the

package box (package), the In-vehicle Emergency Call System/Device has no mechanical defects and the In-vehicle Emergency Call System/Device operability tests are completed successfully.]

[Annex 8

Details of dynamic testing for e-call devices

1. Preparation for the test

1.1 In-Vehicle Emergency Call System/Device main components (see section 2.2 of this Regulations) shall be rigidly fasten on the test cart by means of the same elements of fastening which will be used for installation of the main components of the In-Vehicle Emergency Call System/Device on the vehicle, and this fastening shouldn't increase strength of the specified components.

1.2 Slowdown of the test cart is defined with the help of system measurement for frequency characteristics with a class 60, corresponding to characteristics of the international ISO 6487 (2002) standard.

2. Dynamic test

2.1 After installation of the main components of the In-Vehicle Emergency Call System/Device on the test cart, a slowdown is imparted so that the curve could not go beyond the schedule given in the picture below, and the general change of speed ΔV shall be 50 ± 2 km/h.

3. The In-Vehicle Emergency Call System/Device performance check.

3.1. If In-Vehicle Emergency Call System/Device main components have no visible damage which allow to conclude about their disability, these components are dismantled from the test cart. Joint of sockets of electric cables of the main components according to instructions of the In-Vehicle Emergency Call System/Device is made. It is allowed to make also joint of sockets of electric cables without dismantle of the main components from the test cart.

3.2. The In-Vehicle Emergency Call System/Device is considered to be workable if on completing the dynamic test it conforms the requirements of sections 6.4 and 6.5 of these Regulations.

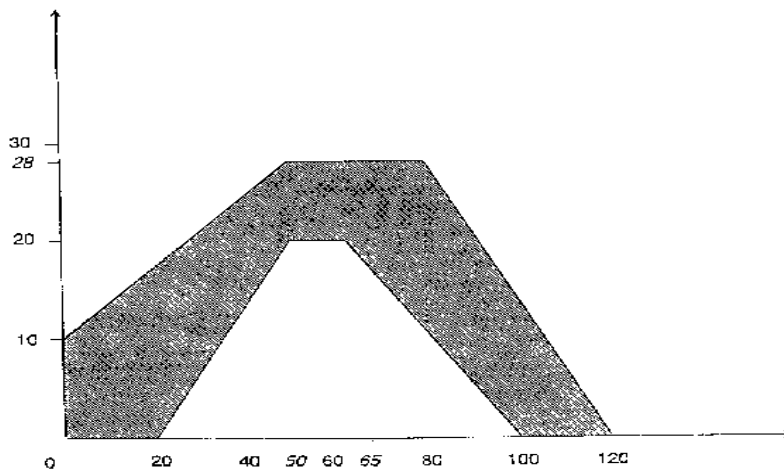

SLED DECELERATION CORRIDOR AS A FUNCTION OF TIME
(Frontal impact)]

[Annex 9 Test methods for the navigation module

1. Definitions

For the purposes of this Annex:

1.1 ““Cold” start mode” – the condition of navigation module of global navigation satellite system, in which the system time, location coordinates, global navigation satellite system almanac and ephemerides of navigation spacecrafts are unknown;

1.2 “Test mode” – the function mode of the In-vehicle Emergency Call System/Device meant for the check of functions and parameters of the In-vehicle Emergency Call System/Device during system operation in the vehicle and also during the In-vehicle Emergency Call System/Device tests.

2. Test conditions

2.1 The test object is the In-Vehicle Emergency Call System/Device, which includes navigation receiver and global navigation satellite system antenna, specifying navigation characteristics and features of the tested system.

- **2.1.1 The number of the In-Vehicle Emergency Call System/Device test samples shall be at least 3 pcs.**

2.1.2 The In-Vehicle Emergency Call System/Device is provided for the test with the installed SIM-card, operation manual and the software (provided on electronic media).

2.1.3 The attached documents shall contain the following data:

- device serial number;
- hardware version;
- software version;
- device provider identification number ;
- unique device identifier, assigned by the system operator in case of the first activation of the device.

Note: For carrying out tests the originals of the operation manual containing specified convergence shall be provided.

2.1.4 The navigation receiver shall give out the measured navigation parameters in a NMEA-0183 protocol format (RMC, GGA, VTG, GSA and GSV message) [5] in external devices. The order of the In-Vehicle Emergency Call System/Device setup for output in external devices of the specified information shall be reflected in the operation manual

2.2 The test goal consists in the compliance assessment of navigation characteristics and properties of the In-Vehicle Emergency Call System/Device determined by the navigation module included in its structure, to following requirements:

2.2.1 The navigation receiver being a part of the In-Vehicle Emergency Call System/Device has to receive and process for the purpose of coordinates determination of location and components of a speed vector the vehicle signals of standard accuracy in the range of L1 of global navigation satellite system.

2.2.2 The navigation receiver being a part of the In-Vehicle Emergency Call System/Device can receive and process for the purpose of coordinates determination of location and components of a speed vector the vehicle signals of standard accuracy of several global navigation satellite systems.

2.2.3 The navigation receiver being a part of the In-Vehicle Emergency Call System/Device shall receive and process signals of all supported global navigation satellite systems with similar priorities and shall use RAIM function for detection of satellites which information can not be used at calculations of navigation characteristics.

2.2.4 The navigation receiver being a part of the In-Vehicle Emergency Call System/Device shall provide detection of navigation parameters in the coordinate system GP-90.02 or WGS-84.

2.2.5 Limit errors (at confidence factor 0,95) have to be not more than:

- plane coordinates – 15 m;
- height – 20 m;
- speed vector – 0,1 m/sec.

The specified requirements for accuracy shall be provided:

- speed range from 0 to 250 km/h;
- linear acceleration range from 0 to 2 G;
- in the presence of short-term vertical accelerations from 0 to 5 G.
- at values of a spatial geometrical factor not more than 4;
- at absence and at influence of the hindrances which admissible level is set by requirements according to sec. 6.1 of this Regulation.

2.2.6 The minimum time interval of observation data updating shall be not more than 1 sec.

2.2.7 Recovery time of tracking signals of working constellation of the navigation spacecraft after loss of tracking them for 60 sec. shall be not more than 5 sec. after recovery of the navigation spacecraft visibility.

2.2.8 Time before receiving the navigation decision of the first ignition start by the navigation receiver shall be not more than 60 sec.

2.2.9 The navigation receiver being a part of the In-Vehicle Emergency Call System/Device shall provide:

- search (detection) for global navigation satellite system at the level of valid signal at the antenna in-put (antenna amplifier in-put) minus 163 Dbw;
- Tracking for global navigation satellite system signals and issue of the navigation decision at the level of valid signal at the antenna in-put (antenna amplifier in-put) minus 188 Dbw.

2.2.10 If the navigation receiver allows changing of frequency issue of navigation data, then appropriated frequency of their issue shall be set by means of set parameter GNSS_DATA_RATE, out of set value range in accordance with Annex A.

2.2.11 If the navigation receiver does not allow changing of frequency issue of navigation data, then the supported by the navigation receiver shall be set by means of set parameter GNSS_DATA_RATE, out of set value range in accordance with Annex A.

2.2.12 Minimum elevation angle (extinction angle) of navigation spacecrafts shall be set by means of set parameter GNSS_MIN_ELEVATION out of set value range in accordance with Annex A. The default value is 5 degrees.

2.2.13 There shall be a possibility of following functions performance in navigation receiver test mode:

- control of the navigation receiver settings with use of the software of the receiver developer;
- output of navigation and temporal information in a format NMEA-0183;
- issue of independent monitoring of integrity (reliability) of navigation determination results and exception of doubtful measurements (RAIM function).

Note – test mode of navigation receiver is used for the In-Vehicle Emergency Call System/Device compliance test regarding requirements for navigation receiver. The In-Vehicle Emergency Call System/Device compliance test regarding requirements for navigation receiver is meant to use navigation and temporal information in a format NMEA-0183.

2.2.14 For the In-Vehicle Emergency Call System/Devices, installed in additional configuration, navigation receiver power supply shall turn off after ignition stop in a time period set by GNSS_POWER_OFF_TIME parameter.

2.2.15 The navigation receiver shall provide performing of functional requirements in case of valid signals level minus 161 Dbw, and influence of harmonic noises with the power levels on an antenna input, equal to the threshold values, specified:

- in Table 1 - by operation on GLONASS signals of standard accuracy;
- in Table 2 - by operation on GPS signals.

Table 1 – Threshold values of harmonic noises at operation on GLONASS signals of standard accuracy

Frequency, MHz	Threshold values of noise level, Dbw
F < 1540	Minus 15
1540 < F ≤ 1562	From minus 15 to minus 50
1562 < F ≤ 1583	From minus 50 to minus 90
1583 < F ≤ 1593	From minus 90 to minus 140
1593 < F ≤ 1609	Minus 140
1609 < F ≤ 1613	From minus 140 to minus 80
1613 < F ≤ 1626	From minus 80 to minus 60
1626 < F ≤ 1670	From minus 60 to minus 15
F > 1670	Minus 15

Table 2 – Threshold values of harmonic noises at operation by GPS signals

Frequency, МГц	Threshold values of noise level, Dbw
$F < 1525$	Minus 15
$1525 < F \leq 1565$	From minus 50 to minus 140
$1565 < F \leq 1585$	Minus 140
$1585 < F \leq 1610$	From minus 140 to minus 60
$1610 < F \leq 1626$	From minus 60 to minus 50
$1626 < F \leq 1670$	From minus 50 to minus 15
$F > 1670$	Minus 15

2.2.16 Navigation module shall provide tracking for global navigation satellite systems GLONASS signals and GPS under influence of impulse noises at antenna input, formed in frequency linear of received global navigation satellite systems GLONASS signals and GPS signals, with parameters set in Table 3, by valid signal capacity minus 161 Dbw.

T a b l e 3 – Impulse noise parameters

Parameter name	Value
Threshold noise value (impulse peaking capacity), Dbw	Minus 10
Impulse duration, ms	≤ 1
Pulse ratio	≥ 10

2.2 Test conditions

2.3.1 The In-Vehicle Emergency Call System/Device tests are performed in test mode.

2.3.2 Tests are carried out in normal climatic conditions in accordance with following factors:

ambient air temperature – $(25 \pm 10)^\circ\text{C}$;

relative air humidity – from 45% to 80 %;

atmospheric pressure – from 84.0 to 106.7 kPa (from 630 to 800 mm Hg).

N o t e: During the test the sample shall be in the range of working temperature stated in operational documentation.

2.3.3 Power supply of the tested In-Vehicle Emergency Call System/Device is from board network of the vehicle. Test procedure “on/off” of the In-Vehicle Emergency Call System/Device, reflected in corresponded paragraphs of test methods, given in section 3, corresponds to the “on/off” procedure of the ignition start of the vehicle and shall be performed by means of toggle or other breaker giving (breaking) power supply of board network emulator.

2.3.4 Technical service of tested samples during tests is not conducted.

2.3.5 Test mode are specified in corresponding paragraphs of test methods, given in section 3.

2.3.6 For carrying out tests of the In-Vehicle Emergency Call System/Device regarding the navigation receiver test and auxiliary equipment is applied and also measure instruments, given in Table 4. Instead of stated in the table test equipment it is allowed to apply other similar

means providing determination of characteristics of satellite navigation equipment with required accuracy.

T a b l e 4 – The list measure instruments of test and auxiliary equipment

Equipment name	Required technical characteristics of test equipment	
	Scale range	Scale accuracy
Geodetic point	Coordinates shall be presented in systems of geodetic parameters of Earth 1990 г. (GP - 90.02) and WGS-84	Difference of coordinates by transfer from a geodetic points network not more than 0,1 m. Average quadratic inaccuracy in determination of coordinates according to the geodetic points is GP -90.02, WGS-84 not more 0,1 m
Global navigation satellite system antenna	Range of working frequencies (1570–1610) Mhz; Amplification factor 41 Db Range of noise coefficient L1 GNCC, not more 3,5 Db	Inaccuracy of amplification factor +2,5 Db
Global navigation satellite system emulator of GLONASS and GPS	Amount of emulated signals – at least 12	Average quadratic deviation of random accuracy component of unrequested range to the global navigation satellite system GLONASS/GPS not more: - <i>stadiometric code phase</i> – 0,1 m; - <i>communication carrier phase</i> – 0,001 m; - <i>pseudovelocity</i> – 0,005 m/sec.
Digital stopwatch	Maximum count volume – 9h 59 min 59,99sec	Daily variation at (25+5)°C not more + 1,0sec. Time discreteness- 0,01sec.
Vector network 58signalli	Frequency range 300 kHz.. 4 HHz Dynamic range (minus 85 .. 40) Db	$Acc_F 1 \cdot 10^{-6}$ $Acc_A (0,1 .. 0,5) Db$
Low-noise booster	Frequency range 950 .. 2150 Mhz Noise coefficient not	

Equipment name	Required technical characteristics of test equipment	
	Scale range	Scale accuracy
	more 2,0 Db Amplifier coefficient 24 ± 2 Db	
Attenuator	Dynamic range (0 .. 11) Db	Acc $\pm 0,5$ дБ
Attenuator	Dynamic range (0 .. 110) Db	Acc $\pm 0,5$ дБ
Power source	Range of direct current voltage setting from 0,1 to 30 V Current intensity of output voltage at least 3A	Acc ₀ $\pm 3\%$ Acc ₁ $\pm 1\%$
Signals generator	Frequency range (1...2)HHz; Dynamic range (minus 150... minus 5) Dbw	Acc _F $\pm 1 \cdot 10^{-6}$ Acc _A (0,5 .. 0,9) дБ
Oscilliscop e	Pass band at least 2 ГГц; Discretization frequency at least 40 HHz; Dynamic range from 1 mV to 3 V.	Acc _T $\pm 1 \cdot 10^{-6}$ Acc _A $\pm 3\%$
N o t e – it is allowed to apply other similar types of equipment providing determination of characteristics with required accuracy.		

100.17 If when carrying out tests calculation of inaccuracy by the navigation module of coordinates of location and speed of movement is carried out by means of the special software, the program for doing calculations shall be based on use of the formulas given in section 3.

3. Test procedure

3.1 Check of the possibility of receiving and processing of navigation signals of standard accuracy in the range of L1 GNSS GLONASS for the purpose of coordinates determination of location and components of a speed vector of the vehicle.

3.1.1 To make connection according to Figure 1.

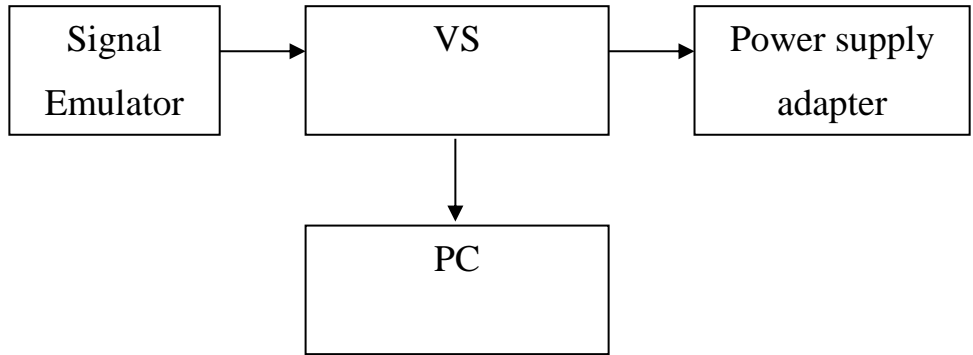

Figure 1 – Diagram of test stand

3.1.2 To arm the In-Vehicle Emergency Call System/Device according to operation manual. Turn on the In-Vehicle Emergency Call System/Device. By means of operation manual and developer software set up the navigation module for receiving signals only from global navigation satellite system GLONASS.

3.1.3 To arm emulator according to the emulator user guide. To initialize emulator script with the movement parameters, given in Table 5, only for GNSS GLONASS signals.

Table 5 – Main parameters of movement emulation with acceleration to maximum speed

Emulated parameter	Value
Duration ES, hh:mm:ss	01:00:00
VS. start point: - CS WGS-84; - PG-90.02.	Midland of Russia Midland of Russia
VS. movement model: - movement with acceleration to maximum speed, km/h- acceleration, g	250 2
Transmission parameters NS: - troposphere: - Ionosphere.	Standard model “Autumn”
Geometric factor PDOP	≤ 4
Emulated signals	- GNSS GLONASS (L1 frequency range code); - GNSS GPS (L1 frequency range code); - GNSS GLONASS/GPS.
Amount of emulated NSC	- at least 8 NSC GNSS

Emulated parameter	Value
	GLONASS; - at least 8 NSC GNSS GPS.

3.1.4 Check of the possibility of receiving and processing of navigation signals of global navigation satellite system GLONASS is completed successfully if coordinates of location and speed vector components of the In-Vehicle Emergency Call System/Device are defined , which are shown on PC.

3.2 Check of the possibility of receiving and processing of navigation signals of standard accuracy in the range of L1 global navigation satellite system GPS for the purpose of coordinates determination of location and components of a speed vector of the vehicle.

3.2.1 To make connection according to Figure 1.

3.2.2 To arm the In-Vehicle Emergency Call System/Device according to operation manual. Turn on the In-Vehicle Emergency Call System/Device. By means of operation manual and developer software set up the navigation module for receiving signals only from global navigation satellite system GNSS GPS.

3.2.3 To arm emulator according to the emulator user guide. To initialize emulator script with the movement parameters, given in Table 5, only for global navigation satellite system with GPS.

3.2.4 Check of the possibility of receiving and processing of navigation signals of global navigation satellite system GPS is completed successfully if coordinates of location and speed vector components of the In-Vehicle Emergency Call System/Device are defined , which are shown on PC.

3.3 Check of the possibility of receiving and processing of navigation signals of standard accuracy in the range of L1 GNSS GLONASS and GPS for the purpose of coordinates determination of location and components of a speed vector of the vehicle.

3.3.1 To make connection according to Figure 1.

3.3.2 To arm the In-Vehicle Emergency Call System/Device according to operation manual. Turn on the In-Vehicle Emergency Call System/Device. By means of operation manual and developer software set up the navigation module for receiving signals only from global navigation satellite system GLONASS and GPS.

3.3.3 To arm emulator according to the emulator user guide. To initialize emulator script with the movement parameters, given in Table 5, only for GNSS GLONASS and GPS signals.

3.3.4 Check of the possibility of receiving and processing of navigation signals of global navigation satellite system GLONASS and GPS is completed successfully if coordinates of location and speed vector components of the In-Vehicle Emergency Call System/Device are defined , which are shown on PC.

3.4 Check of possibility of issue of information on navigation parameters in NMEA-0183 format to the external devices.

3.4.1 To make connection according to Figure 1.

3.4.2 To arm the In-Vehicle Emergency Call System/Device according to operation manual. Turn on the In-Vehicle Emergency Call System/Device. By means of operation manual and developer software set up the navigation module for receiving signals only from global

navigation satellite system GLONASS and GPS. Set up the navigation module for issue of NMEA-0183 messages (messages RMC, GGA, VTG, GSA and GSV according to [5]).

3.4.3 To arm emulator according to the emulator user guide. To initialize emulator script with the movement parameters, given in Table 6, only for GNSS GLONASS signals.

Table 6 – Main parameters of emulating script of fixed space point

Emulated parameter	Value
Duration ES, hh:mm:ss	01:00:00
VS. location: - CS WGS-84; - PG-90.02.	Midland of Russia Midland of Russia
Transmission parameters NS: - troposphere: - Ionosphere.	Standard model “Autumn”
Geometric factor PDOP	≤ 4
Emulated signals	- GNSS GLONASS (L1 frequency range CT code); - GNSS GPS (L1 frequency range C/A code); - GNSS GLONASS/GPS.
Amount of emulated NSC	- at least 8 NSC GNSS GLONASS; - at least 8 NSC GNSS GPS.

3.4.4 By means of corresponding interface to set the connection between the In-Vehicle Emergency Call System/Device and personal computer. To control the possibility of receiving navigation information via NMEA-0183 protocol.

3.4.5 Test results are successful if navigation information via NMEA-0183 protocol is received.

3.5 Check of autonomous control of reliability of navigation definitions and excluding of unreliable measurements (RAIM)

3.5.1 To establish the diagram, given in Figure 1.

3.5.2 To form the emulator script by means of special software for signals emulator for static object with modulated errors of ephemerically-temporal information for 3 navigation spacecrafts upon 10 min. from the script start.

3.5.3 To start emulated script.

3.5.4 Upon 10 min. of script emulation by means of special software for the global navigation satellite system to make sure of the received signals absence of navigation spacecrafts, for which errors of ephemerically-temporal information are modulated.

3.5.5 Test results are considered to be successful if requirements of par. 3.5.4 are conformed.

3.6 Check of determination possibility for navigational parameters in the coordinate system GP-90.02 и WGS-84

3.6.1 To establish the diagram, given in Figure 1.

3.6.2 To arm the In-Vehicle Emergency Call System/Device according to the operation manual. Enable the In-Vehicle Emergency Call System/Device. By means of operation manual and developer software set up the navigation module for receiving GNSS GLONASS signals and issue of navigational parameters in the coordinate system GP -90.02.

Note – It is allowed to use PIRTR message for working coordinate system set up.

3.6.3 To arm the emulator according to the operation manual. To start emulation script with the movement direction parameters, given in Table 6, only for GNSS GLONASS signals.

3.6.4 To make sure those navigational parameters with the use of GNSS GLONASS signals are successfully calculated and are reflected in the coordinate system GP -90.02 (DTM message).

3.6.5 To set up the navigation module for message issue according to NMEA-0183 protocol (GGA, RMC, VTG, GSA and GSV messages) with the frequency 1 Hz.

3.6.6 To record messages, issued by navigation module of global navigation satellite system, to the file, until the end of script.

3.6.7 To repeat test procedures according to 3.6.1 – 3.6.5 for the working coordinate system WGS-84.

3.6.8 To choose from each data unit recorded in accordance with 3.6.6, 50 GGA (RMC) messages of the same time moments.

3.6.9 To recalculate coordinates from the measured coordinate system to another one.

3.6.10 To compare determined during the test coordinates with the recalculated ones, taking into consideration accepted accuracy value, given in 2.2.15

3.6.11 Test results are considered to be successful if, coordinates data, received during the test corresponds to the calculated one.

3.7 The assessment of accuracy of coordinates determination in plan and height in autonomous static mode.

3.7.1 To establish the diagram, given in Figure 1.

3.7.2 To arm the In-Vehicle Emergency Call System/Device according to operation manual To enable the In-Vehicle Emergency Call System/Device. By means of developer software to make sure that navigation module is set up for receiving global navigation satellite systems GLONASS and GPS signals, and the value of parameter GNSS_MIN_ELEVATION is set in equal to 5 degrees. To set up navigation module for issue of messages according to the NMEA-0183 protocol (GGA, RMC, VTG, GSA and GSV messages) with the frequency of 1 Hz.

Note – The setup of the issue frequency of navigation module messages by the In-Vehicle Emergency Call System/Device is conducted by means of setup parameter GNSS_DATA_RATE.

3.7.3 To arm the emulator in accordance with its operational manual. To start emulation of global navigation satellite system GLONASS signals script with set parameters, given in Table 6.

3.7.4 Upon receiving the navigational decision after the script start, to provide recording of messages issued by navigation module of global navigation satellite system to the file, up to the moment the emulation script is complete.

3.7.5 To specify information contained in GGA (RMC) messages, on determined during the test location coordinates: latitude (B), longitude (L) and height (H).

3.7.6 To calculate the systematic inaccuracy of coordinate's determination on stationarity intervals according to formulas (1), (2), for example for latitude coordinate (B):

$$(1) \Delta B(j) = B(j) - B_{ucmj},$$

(2)

$$dB = \frac{1}{N} \cdot \sum_{j=1}^N \Delta B(j),$$

Where B_{ucmj} – actual value of B coordinate in j-ed time moment, angle sec.;

B_j – determined by the navigation module value of B coordinate in J time moment, angle sec;

N – amount of GGA (RMC) messages, received during the test of navigation module.

Similarly to calculate the systematic inaccuracy of L (longitude) and H (height) coordinates determination.

Note – Height values are counted in meters.

3.7.7 To calculate mean square deviation (MSD) result of coordinates determination according to formula (3), for example for B coordinate:

$$(3) \sigma_B = \sqrt{\frac{\sum_{j=1}^N (B(j) - dB)^2}{N - 1}},$$

Similarly to calculate the (MSD) result of L (longitude) and H (height) coordinates determination

3.7.8 To convert calculated inaccuracy values of latitude and longitude determination from angle seconds to meters according to formulas (4) – (5):

- for latitude:

$$(4) dB(m) = 2 \cdot \frac{a(1 - e^2)}{(1 - e^2 \sin^2 \varphi)^{3/2}} \cdot \frac{0,5'' \cdot \pi}{180 \cdot 3600''},$$

- for longitude:

$$(5) \quad dL(m) = 2 \cdot \frac{a \cdot \cos \varphi}{\sqrt{1 - e^2 \sin^2 \varphi}} \cdot \frac{0,5'' \cdot \pi}{180 \cdot 3600''},$$

Where a – major semiaxes of ellipsoid, m

e – first eccentricity

φ – current latitude, rad.

3.7.9 To calculate coordinates determination inaccuracy in plan and height (at confidence coefficient 0,95) according to formulas (6) and (7) respectively:

$$(6) \quad \Pi_{plan} = \sqrt{dB^2(M) + dL^2(M)} + 2 \cdot \sqrt{\sigma_B^2(M) + \sigma_L^2(M)},$$

$$(7) \quad \Pi_H = dH + 2\sigma_H,$$

3.7.10 To repeat test procedures according to 3.5.3 – 3.5.9 by the emulated script only for global navigation satellite system GPS signals with emulation parameters, given in Table 6.

3.7.11 To repeat test procedures according to 3.5.3 – 3.5.9 by the emulated script of coincident star pattern for global navigation satellite system GLONASS and GPS signals with emulation parameters, given in Table 6.

3.7.12 To repeat test procedures according to 3.5.3 – 3.5.11 others in-vehicle emergency call device samples, provided for the test.

3.7.13 To determine average values according to their results (6) and (7) regarding general number of tested in-vehicle emergency call device samples.

3.7.14 To connect global navigation satellite system antenna, included in the system, to the tested sample and turn on the mode of receiving signals of corresponding global navigation satellite system. To repeat test procedures according to 3.5.4 – 3.5.13 in real time at sending navigational signals from antenna, located in the geodetic point (defining point) according to real signals:

- GNSS GLONASS;
- GNSS GPS;
- coincident GNSS GLONASS/GPS.

N o t e – Switching of navigation module to the receiving signals of corresponding global navigation satellite system mode or to the mode of coincident star pattern, is conducted in order, given in operation manual of the In-Vehicle Emergency Call System/Device.

3.7.15 Tests results are considered to be satisfactory, if inaccuracies of coordinate and height determination obtained during the test (at confidence coefficient 0,95) do not exceed accepted value, given in paragraph 2.2.15

3.8 The inaccuracy assessment of coordinate determination in plan, height and speed in dynamic mode.

3.8.1 To establish the diagram according to Figure 1.

3.8.2 To arm the In-Vehicle Emergency Call System/Device in accordance with its operational manual. Turn on the In-Vehicle Emergency Call System/Device. By means of developer software to make sure that navigation module is set up for receiving global navigation satellite systems GLONASS and GPS signals, and the value of parameter GNSS_MIN_ELEVATION is set in equal to 5 degrees. To set up navigation module for issue of messages according to the NMEA-0183 protocol (GGA, RMC, VTG, GSA and GSV messages) with the frequency of 1 Hz.

Note – The setup of the issue frequency of navigation module messages by the In-Vehicle Emergency Call System/Device is conducted by means of setup parameter GNSS_DATA_RATE.

3.8.3 To arm the emulator in accordance with its operational manual. To start the emulated script for maximum speed movement set in the operational documentation of tested In-Vehicle Emergency Call System/Device, with imitation of only GNSS GLONASS signals (Table 5).

3.8.4 Upon receiving the navigational decision after the script start, to provide recording of messages issued by navigation module of global navigation satellite system to the file, up to the moment the emulation script is complete.

3.8.5 To specify information contained in messages, on determined during the test location coordinates: (latitude, longitude, height) and speed.

3.8.6 To calculate the inaccuracy of coordinate's determination in plan and height (for the confidence coefficient 0,95) according to formulas (1) – (7).

3.8.7 To calculate the systematic inaccuracy and average quadratic deviation from result of speed determination, according to formulas (8) – (10):

$$\Delta V(j) = V(j) - V_{ucmj}, \quad (8)$$

$$dV = \frac{1}{N} \cdot \sum_{j=1}^N \Delta V(j), \quad (9)$$

$$\sigma V = \sqrt{\frac{\sum_{j=1}^N (V(j) - dV)^2}{N - 1}}, \quad (10)$$

Where V_{ucmj} – actual value of speed in j -ed time moment, m/sec.;

V_j – determined value of speed in J time moment, m/sec.;

N – the number of GGA (RMC) messages, received during the test of navigation module.

3.8.8 To calculate inaccuracy (at confidence coefficient 0,95) of speed determination according to formula (11):

$$(11) \quad \Pi_V = dV + 2\sigma_V$$

3.8.9 To switch the emulated script for maximum speed movement to the signal emulation mode from global navigation satellite system GPS only, and conduct procedures according to 3.6.4 – 3.6.8.

3.8.10 To switch the emulated script for maximum speed movement to mode of star pattern emulation signals mode of global navigation satellite systems GLONASS and GPS and conduct procedures according to 3.8.4 – 3.8.8.

3.8.11 To repeat test procedures according to 3.8.2 – 3.8.10 for the rest In-Vehicle Emergency Call System/Device samples, provided for the test.

3.8.12 To determine average values (6), (7) and (11) according to In-Vehicle Emergency Call System/Device test results with the use of emulated script of maximum speed movement (Table 1) regarding general number of tested In-Vehicle Emergency Call System/Device samples.

3.8.13 To repeat test procedures according to 3.8.2 – 3.8.12 for emulation scripts for maneuvering movement (Table 7) and movement in shadow areas and areas of intermittent reception of navigation signals (Table 8).

T a b l e 7 – Main parameters of emulation scripts for maneuvering movement

Emulated parameter	Value
Duration, hh:mm:ss	02:00:00
Start point of VS.: - CS WGS-84; - GP-90.02.	Midland of Russia Midland of Russia
Vs. model of movement: - speed, m/sec; turn radius, m; - turn acceleration, m/sec ²	Maneuvering movement 10 500 0,2
Propagation medium parameters of NS: - troposphere: - Ionosphere.	Standard model “Autumn”
Geometric factor PDOP	≤ 4

Emulated signals	<ul style="list-style-type: none"> - GNSS GLONASS (L1 frequency range code); - GNSS GPS (L1 frequency range code); - GNSS GLONASS/GPS.
Amount of emulated NSC	<ul style="list-style-type: none"> - at least 8 NSC GNSS GLONASS; - at least 8 NSC GNSS GPS.

Table 8 – Main parameters of movement in shadow areas and areas of intermittent reception of navigation signals

Emulated parameter	Value
Duration ES, hh:mm:ss	01:00:00
VS. start point: - CS WGS-84; - PG-90.02.	Midland of Russia Midland of Russia
Vs. model of movement: - maximum speed, m/sec;	Maneuvering movement 10
NS radiovisibility : - signal visibility intervals, sec; - signal absence intervals, sec.	300 600
Propagation medium parameters of NS: - troposphere: - Ionosphere.	Standard model “Autumn”
Geometric factor PDOP	≤ 4
Emulated signals	- GNSS GLONASS (L1 frequency range code); - GNSS GPS (L1 frequency range code); - GNSS GLONASS/GPS.
Amount of emulated NSC	- at least 8 NSC GNSS GLONASS; - at least 8 NSC GNSS GPS.

3.7.14 To specify average values(6), (7) and (11) according to the In-Vehicle Emergency Call System/Device test results, in dynamic mode, regarding general number of emulation scripts conducted for this mode.

3.7.15 Test results of the In-Vehicle Emergency Call System/Device in dynamic mode are considered to be satisfactory, if obtained during the tests inaccuracies (at confidence coefficient 0,95) of coordinate determination in plan, height and speed do not exceed values, given in 2.2.15.

3.9 Check of minimum time interval of observatory data update.

3.9.1 To 70ignall file with tests results according to par. 3.6. To make sure in the absence of equal coordinate values for related (in time) GGA messages.

3.9.2 The test result is considered to be positive in case of the 70ignalling of the condition 3.9.1.

3.10 Restoration time check of working star pattern of navigation spacecrafts tracking signals after loss of tracking because of shadowing.

3.10.1 To arm the In-Vehicle Emergency Call System/Device according to operational manual. To enable the In-Vehicle Emergency Call System/Device. By means of developer software to make sure that global navigation satellite system module is set for the signal receiving from global navigation satellite systems GLONASS and GPS.

3.10.2 To connect the global navigation satellite system antenna to the In-Vehicle Emergency Call System/Device.

3.10.3 To wait for the receiving of navigation decision by navigation module of the In-Vehicle Emergency Call System/Device.

3.10.4 To disconnect antenna from the In-Vehicle Emergency Call System/Device (navigation module) and connect it again after time interval of 60 sec.

By means of stopwatch to fix time interval between antenna connection/disconnection moments and appearing information on restoration of tracking for navigational spacecrafts out of working star pattern (receiving of the first navigation decision), in interface dialogue window.

3.10.5 Test procedure according to 3.10.4 to repeat at least 30 times.

3.10.6 According to data selection from measurements to calculate average value of restoration time of tracking signals from star pattern of navigation spacecrafts by the In-Vehicle Emergency Call System/Device exit from shadow area, regarding the number of In-Vehicle Emergency Call System/Device samples, provided for the test.

3.10.7 The test result is considered to be positive, if average time value of restoration of tracking signals from star pattern of navigation spacecrafts after loss of tracking because of shadowing for is no longer than 5 sec., after restoration of visibility.

3.10.8 By means of software the In-Vehicle Emergency Call System/Device and operational manual to set up navigation module the In-Vehicle Emergency Call System/Device for receiving of signals only from navigation spacecrafts GLONASS and repeat procedures in 3.10.2 – 3.10.7.

3.10.9 By means of software the In-Vehicle Emergency Call System/Device and operational manual to set up navigation module the In-Vehicle Emergency Call System/Device for receiving of signals only from navigation spacecrafts GPS and repeat procedures in 3.10.2 – 3.10.7.

3.11 Check of making navigation decision time in a “cold” start mode.

3.11.1 To arm the In-Vehicle Emergency Call System/Device according to operational manual. To enable the In-Vehicle Emergency Call System/Device. By means of developer software to make sure that GNSS module is set for receiving signals from global navigation satellite system GLONASS and GPS.

3.11.2 To reset all navigation spacecrafts and almanacs ephemerides from random access memory of navigation receiver.

3.11.3 To connect global navigation satellite system antenna to the In-Vehicle Emergency Call System/Device. By means of a stop watch to mark time interval between the moments of

antenna connection and appearance in the interface dialog window of navigation decision result.

3.11.4 To conduct test procedures according to 3.11.2 и 3.11.3 at least 30 times.

3.11.5 According to data selection from measurements to calculate making navigation decision time in a “cold” start mode (known almanac, ephemerides, time, coordinates) regarding the number of In-Vehicle Emergency Call System/Device samples, provided for the test.

3.11.6 By means of software the In-Vehicle Emergency Call System/Device and operational manual to set up navigation module the In-Vehicle Emergency Call System/Device for receiving of signals only from navigation spacecrafts GLONASS and repeat procedures in 3.11.2 – 3.11.5.

3.11.7 By means of software the In-Vehicle Emergency Call System/Device and operational manual to set up navigation module the In-Vehicle Emergency Call System/Device for receiving of signals only from navigation spacecrafts GPS and repeat procedures in 3.11.2 – 3.11.5.

3.11.8 The test result is considered to be positive, if average value of time interval, calculated according to 3.11.5, do not exceed 60 sec.

3.12 Determination of navigation receiver sensitivity in a search mode (capture) and in a mode of holding (tracking) of global navigation satellite system signals.

3.12.1 To turn on the vector 71gnalli of circuits. To make calibration of the vectorial 71gnalli of circuits according to its operational manual.

3.12.2 To establish the diagram according to Figure 2.

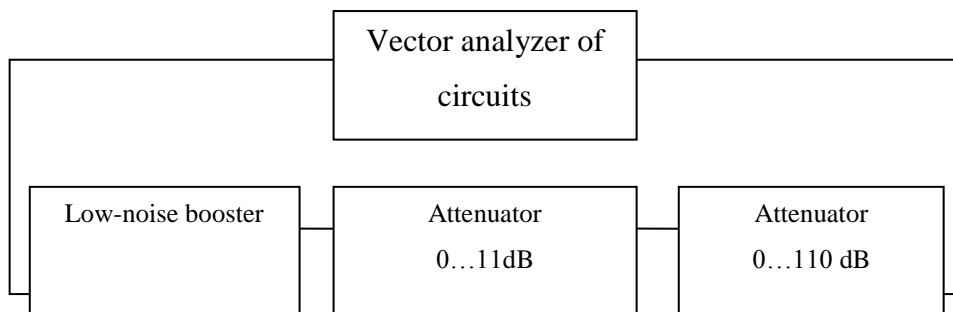

Figure 2 – Diagram of route calibration

3.12.3 To set route depression values in “0” on the attenuators. To make measures of frequency-response characteristic of this route in a frequency range L1 of global navigation satellite systems GLONASS/GPS signals. To fix an average value of route transfer constant in [dB] in this frequency range.

3.12.4 To establish the diagram according to Figure 3.

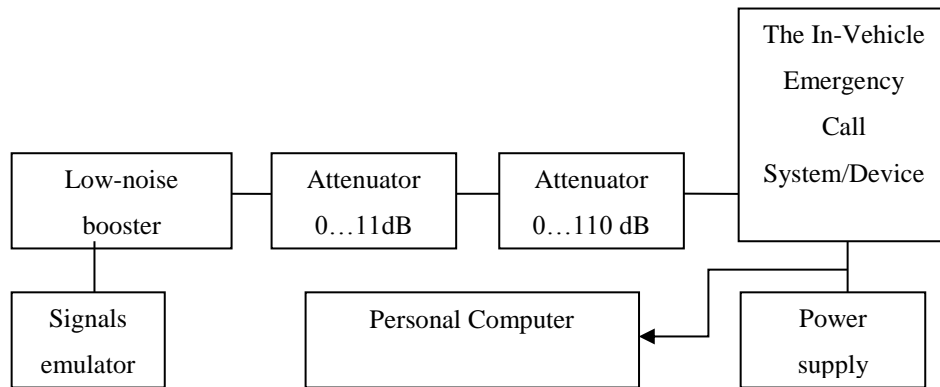

Figure 3 – Diagram of determination of GNSS module sensitivity

3.12.5 To arm the In-Vehicle Emergency Call System/Device according to operational manual. To enable the In-Vehicle Emergency Call System/Device. By means of developer software to make sure that GNSS module is set for receiving signals from global navigation satellite system GLONASS and GPS. To reset all navigation spacecrafts and almanacs ephemerides from random access memory of navigation receiver, that promotes “cold” start mode of the navigation module of the In-Vehicle Emergency Call System/Device.

3.12.6 To set in route depression values equal to 110 dB. To arm emulator according to its operation manual. To start GNSS GLONASS/GPS signals emulation script, with parameters given in Table 6. To set output power level minus 150 Dbw in the emulator.

3.12.7 To control data, time and coordinates reset in a dialog window.

3.12.8 With 1 dB step to decrease route depression on attenuators (to increase the capacity of a navigation signal on an input of the navigation module) till the moment when the In-Vehicle Emergency Call System/Device makes navigation decision. To fix global navigation satellite system signal level on an input of the In-Vehicle Emergency Call System/Device antenna regarding starting value of route transfer constant in search (capture) mode global navigation satellite system signal.

Note – The switching of attenuators shall be done with periodicity at least 120 sec. for presence/absence control of navigation decision issued by navigation receiver of the In-Vehicle Emergency Call System/Device.

3.12.9 To set on attenuatorax route depression value of such kind that the value of In-Vehicle Emergency Call System/Device antenna input signal was minus 160 Dbw. Let the navigation module to get ephemerides and almanac of global navigation satellite system during 15 min.

3.12.10 With 1 dB step to increase route depression on attenuators (to decrease the capacity of a navigation module) till reset of navigation decision. To fix global navigation satellite system signal level on an input of the In-Vehicle Emergency Call System/Device antenna regarding starting value of route transfer constant in holding (tracking) mode global navigation satellite system signal.

3.12.11 Test results are considered to be positive, if for all In-Vehicle Emergency Call System/Device samples, provided for the test, fixed in 3.10.8 global navigation satellite system signal level at the In-Vehicle Emergency Call System/Device antenna input in search mode does not exceed minus 163 Dbw and if fixed in 3.10.10 global navigation satellite system signal level at the In-Vehicle Emergency Call System/Device antenna input in holding (tracking) mode does not exceed minus 188 Dbw.

3.13 Check of possibility of data issue frequency change in required value range with the help of setup parameter GNSS_DATA_RATE

3.13.1 To establish the diagram according to Figure 4.

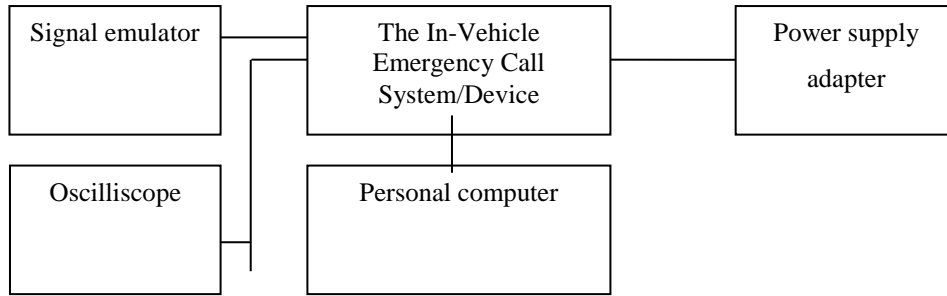

Figure 4 – Diagram of test stand

Notes

1. Tests are recommended to combine with tests given in 3.6.
2. For the In-Vehicle Emergency Call System/Device, the navigation receiver of which does not allow changing of data issue frequency, tests are conducted in accordance with 3.13.2 – 3.13.5.
3. For the In-Vehicle Emergency Call System/Device, the navigation receiver of which allows changing of data issue frequency, tests are conducted in accordance with 3.13.2 – 3.13.8 after completing the tests for navigation parameters assessment by mated group GLONASS/GPS according to 3.8.

3.13.2 To arm the In-Vehicle Emergency Call System/Device in accordance with its operational manual. Turn on the In-Vehicle Emergency Call System/Device. By means of developer software to make sure that navigation module is set up for receiving global navigation satellite systems GLONASS and GPS signals. To set up navigation module for issue of messages according to the NMEA-0183 protocol (GGA, RMC, VTG, GSA and GSV messages) with the frequency of 1 Hz.

Note – The setup of frequency of navigation messages by navigation receiver of the In-Vehicle Emergency Call System/Device is performed by means of set parameter GNSS_DATA_RATE.

3.13.3 To turn on 73ignalling73e and set signals receiving in specified frequency range.

3.13.4 To arm emulator according to its operation manual. To start the script for acceleration to maximum speed movement stated in the tested the In-Vehicle Emergency Call System/Device operation manual, with imitation of global navigation satellite systems GLONASS and GPS signals (Table 5).

3.13.5 By receiving of navigation decision to make sure by means of 73ignalling73e that frequency of data issue by navigation module corresponds to the stated one.

3.13.6 To stop emulation script in set parameters of global navigation satellite system receiver (set parameter GNSS_DATA_RATE) to set another frequency value, for example 2 Hz.

3.13.7 To start emulation script and to make sure by means of 74ignalling74e that frequency of data issue by navigation module corresponds to the stated one.

3.13.8 To repeat par. 5.11.6 and 3.11.7 with successive parameter set value GNSS_DATA_RATE, equal to 5 and 10 Hz.

3.13.9 Test result is considered to be positive if for all In-Vehicle Emergency Call System/Device samples, provided for the test, a setup of different data issue frequency, defined by parameter GNSS_DATA_RATE is possible, in value range 1, 2, 5, 10 Hz.

3.14 Check of minimum depression angle (extinction angle) of navigation spacecrafts.

3.14.1 To establish the diagram according to Figure 1.

3.14.2 To arm the In-Vehicle Emergency Call System/Device according to operational manual. To enable the In-Vehicle Emergency Call System/Device. By means of developer software to make sure that navigation module is set for receiving of global navigation satellite systems GLONASS и GPS signals.

3.14.3 By mans of software to set the parameter GNSS_MIN_ELEVATION (minimum depression angle (extinction angle) of navigation spacecrafts), equal to 5°.

3.14.4 To arm emulator according to operational manual. For imitation of global navigation satellite systems GLONASS and GPS signals script (Table 6) to determine out of descending spacecrafts the navigation satellite (GLONASS or GPS), for which t1 timepoint on arriving at elevation angle, equal 5°, will be the next from the moment of emulation script. To record the specified timepoint and the conditional number of the navigation satellite to which this timepoint corresponds.

3.14.5 To start emulation of GLONASS/GPS systems script with the set parameters, given in Table 6.

3.14.6 To see in PC display the chosen navigation spacecraft and to make sure, that upon passing the timepoint t1 it will be excluded from treatment (GSA message). To stop the script.

3.14.7 By means of software to set the parameter GNSS_MIN_ELEVATION (of minimum depression angle (extinction angle) of navigation spacecrafts), equal to 15°.

To repeat par. 3.14.4 – 3.14.6, counting for the start script moment the timepoint t1.

3.14.8 Test results are considered to be positive if, for all the In-Vehicle Emergency Call System/Device samples, provided for the test, the extinction angle for the chosen для navigation spacecrafts corresponds to the stated ones (5°,15°).

3.15 Check of navigation module power off time (global navigation satellite system receiver) after starting the ignition.

3.15.1 To arm the In-Vehicle Emergency Call System/Device according to operational manual. To enable the In-Vehicle Emergency Call System/Device. By means of software to enter the view and change setup parameters mode of the In-Vehicle Emergency Call System/Device.

3.15.2 To check and to record the setup parameter value GNSS_POWER_OFF_TIME in the In-Vehicle Emergency Call System/Device sample, provided for the test. To enter new setup parameter value GNSS_POWER_OFF_TIME, equal to 10 sec.

Note – reference value shall be 500 ms.

3.15.3 To disable the In-Vehicle Emergency Call System/Device and by means of stopwatch to fix actual turning off time of the In-Vehicle Emergency Call System/Device according to system state indicator.

3.15.4 To make sure that for all the In-Vehicle Emergency Call System/Device samples, provided for the test, the fixed actual turning off time corresponds to the stated in par. 3.13.2.

3.15.5 By the order, given in 3.15.1 – 3.15.2, enter the reference parameter value GNSS_POWER_OFF_TIME.

Note –check according to 3.15 is optional for standard systems.

3.16 Check of performance of functional requirements at influence of harmonious noises

3.16.1 To establish the diagram according to figure 5.

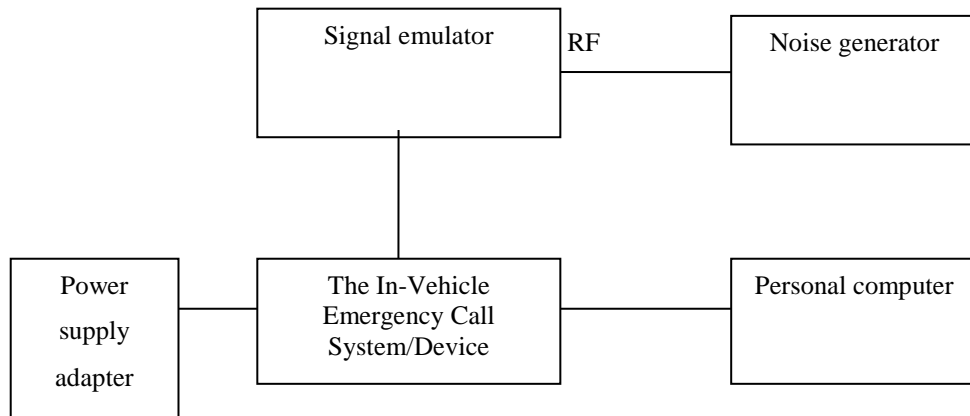

Figure 5 – Test stand diagram

Note: In figure 5 “RF” stands for radio frequency port of signal emulator for sending signals of external noise

3.16.2 To arm the In-Vehicle Emergency Call System/Device according to operational manual. To enable the In-Vehicle Emergency Call System/Device. By means of developer software to make sure that navigation receiver global navigation satellite system is set for receiving GLONASS and GPS signals.

3.16.3 To arm emulator in accordance with operation manual. To set power level of useful signals, equal to minus 161 Dbw.

3.16.4 To arm harmonized noise generator according to operational manual.

3.16.5 To repeat tests given in 3.1, 3.5, 3.7, 3.8, 3.9, 3.10, 3.11, consequently sending harmonized noise in value range, given in Table 1 for the check of GLONASS CT L1 signals work.

3.16.6 Tests are considered to be successful, if for all the In-Vehicle Emergency Call System/Device samples, provided for the test, performance of functional requirements is provided in the mode of work by GLONASS signals for all values of harmonized noise, given in Table 1.

3.16.7 To repeat tests, given in 3.2, 3.5, 3.7, 3.8, 3.9, 3.10, 3.11 consequently sending harmonized noise in value range, given in Table 2 for the check of GPS signals work.

3.16.8 Tests are considered to be successful, if for all the In-Vehicle Emergency Call System/Device samples, provided for the test, performance of functional requirements is provided in the mode of work by GLONASS signals for all values given in Table 2.

3.17 Check of providing global navigation satellite system signals tracking, under impulse noise

3.17.1 To establish the diagram according to figure 5.

3.17.2 To arm the In-Vehicle Emergency Call System/Device according to operational manual. To enable the In-Vehicle Emergency Call System/Device. By means of developer software to make sure that navigation receiver global navigation satellite system is set for receiving GLONASS and GPS signals.

3.17.3 To arm emulator in accordance with operation manual. To set power level of useful signals, equal to minus 161 Dbw.

3.17.4 To wait for 15 minutes and make sure that the global navigation satellite system module switched to the mode of tracking for navigation spacecrafts from global navigation satellite system working star pattern.

3.17.5 To arm impulse noise generator in accordance with its operation manual.

3.17.6 To send impulse noise with set parameters:

- frequency range – from 1565,42 MHz to 1609,36 MHz for GLONASS/GPS;
- threshold value (peak impulse capacity) – minus 10 Dbw;
- impulse duration - ≤ 1 ms ;
- pulse ratio - ≥ 10 .

3.17.7 To watch within 15 minutes in a dialog window of the interface program the information on tracking navigation spacecrafts from working star patterns and transfer of coordinates GLONASS and GPS

3.17.8 Tests are considered to be successful, if for all the In-Vehicle Emergency Call System/Device samples, provided for the test, cases of failures of tracking working star patterns of GLONASS/GPS navigation spacecrafts during influence of an impulse noise.

Annex 9 – Apendix A
Setup parameters of the In-Vehicle Emergency Call System/Device

Parameter name	Unit measure	Parameter type/ parameter interval ²⁾	Initial parameter	Parameter description	Applicability of requirement ¹⁾	Possibility of change of the In-Vehicle Emergency Call System/Device settings ⁴⁾
1	2	3	4	5	6	7
Radio mute						
RADIO_MUTE_DELAY	Milliseconds	INT	0	The delay between setting the “radio mute” signal and beginning of the sound	AD	Yes
RADIO_UNMUTE_DELAY	Milliseconds	INT	0	The delay between disabling the “radio mute” signal and termination of the sound	AD	Yes
General settings						
ECALL_BLACK_LIST	-	Data format ³⁾	Empty list	The list of networks, which do not provide “Emergency call”	AD, SE	Yes
AUTOMATIC_REGISTRATION	-	BOOLEAN	FALSE	The flag allowing automatic registration of SIM in a network after switching on the power	AD, SE	Yes

Table continuation

1	2	3	4	5	6	7
---	---	---	---	---	---	---

1	2	3	4	5	6	7
CALL_ AUTO_ ANSWER_ TIME	Minutes	INT	20	Time interval after the emergency call, when the In-Vehicle Emergency Call System/Device automatically answers to the calls	AD, SE	Yes
SELFTEST_INTERV AL	Hours	INT	0	Interval for self-tests. If the value is set in "0", then regularly self-test is not carried out.	AD, SE	Yes
POST_TEST_ REGISTRATION_ TI ME	Seconds	INT	120	Time interval when the In-Vehicle Emergency Call System/Device stay registered in the network after transmission of self-test results to the system operator.	AD, SE	Yes
TEST_MODE_END_ DISTANCE	Meters	INT	300	Distance at which self-test mode disables automatically.	AD, SE	Yes
GARAGE_MODE_EN D_ DISTANCE	Meters	INT	300	Distance at which "car service" mode disables automatically.	AD	Yes

Table continuation

1	2	3	4	5	6	7
ECALL_TEST_NUM BER	-	STRING	112	Telephone number for eCall test calls	AD, SE	Yes
GARAGE_MODE_PI N	-	ENUM {NONE, PIN_1 – PIN_8}	NONE	The line 78 signalling that system is in a "Car service" mode: - NONE – no mode signalization; - PIN_X – PIN_X – line is active, in case when system is in this mode	AD	Yes
INT_MEM_TRANSMI T_ INTERVAL	Minutes	INT	60	Time interval between attempts of sending message, contained in the entire memory of the In-Vehicle Emergency Call System/Device. The value can be	AD, SE	Yes

1	2	3	4	5	6	7
				“0”		
INT_MEM_TRANSMIT_ATTEMPTS	-	INT	10	The number of repeated attempts of sending message, contained in the entire memory of the In-Vehicle Emergency Call System/Device. The value set in “0” means that repeated attempts are not conducted.	AD, SE	Yes

Table continuation

1	2	3	4	5	6	7
Configuration and configuration service						
Standard service «ERA-GLONASS» (eCall service)						
ECALL_ON	-	BOOLEAN	TRUE	eCall service is on	AD, SE	Yes
CRASH_SIGNAL_INTERNAL	-	BOOLEAN	TRUE	Only vehicles of category M1 – for detection of road accident the built-in accelerometer is used	AD	Yes
CRASH_SIGNAL_EXTERNAL	-	BOOLEAN	FALSE	Only vehicles of category M1 – for detection of road accident the external sensor is used	AD	Yes
ASI15_TRESHOLD	-	REAL	1.8	Only vehicles of category M1 – threshold of automatic road accident identification action	AD	Yes
ECALL_MODE_PIN		ENUM {NONE, PIN_1 .. PIN_8}	NONE	The line signaling, that the system is in eCall mode: - NONE – no mode signalization; - PIN_X – PIN_X – line is active, in case when system is in this mode	AD	Yes

Table continuation

1	2	3	4	5	6	7
SOS_BUTTON_TIME	Milliseconds	INT	200	Time of pushing the “Emergency call” button for mode activation	AD	Yes
CCFT	Minutes	INT	60	Duration of the counter of the automatic call termination (60 m)	AD, SE	Yes
INVITATION_SIGNAL_DURATION	Milliseconds	INT	200	Длительность сигнала INVITATION (2 s)	AD, SE	Yes
SEND_MSG_PERIOD	Milliseconds	INT	200	Message period SEND MSG (2 s)	AD, SE	Yes
AL_ACK_PERIOD	Milliseconds	INT	200	Period AL-ACK (2 s)	AD, SE	Yes
MSD_MAX_TRANSMISSION_TIME	Seconds	INT	20	Maximum time of transmission MSD (20 s)	AD, SE	Yes
NAD_DEREGISTRATION_TIMER	Minutes	INT/more/equal720)	8	Time interval after which the communication module, GSM and UMTS terminate network registration(8 h)	AD, SE	Yes

Table continuation

1	2	3	4	5	6	7
NAD_DEREGISTRATION_TIMER	Minutes	INT/more/e/	8	Time interval after which the communication module, GSM and	AD, SE	Yes

1	2	3	4	5	6	7
		equal720)		UMTS terminate network registration(8h)		
ECALL_DIAL_DURATION	Minutes	INT	5	General time of dialing in emergency mode	AD, SE	Yes
ECALL_AUTO_DIAL_ATTEMPTS	-	INT	10	Only for vehicles of category M1 – the number of dialing attempts during automatically enabled emergency call. Cannot be set in “0”	AD, SE	Yes
ECALL_MANUAL_DIAL_ATTEMPTS	-	INT	10	The number of dialing attempts during manually enabled emergency call. Cannot be set in “0”	AD, SE	Yes
ECALL_MANUAL_CANCEL	-	BOOLEAN	TRUE	TRUE – the emergency call enabled manually can be terminated by the user.	AD, SE	Yes
ECALL_SMS_FALLBACK_NUMBER	-	STRING	112	The number to which the In-Vehicle Emergency Call System/Device sends SMS with MDS at system operators request	AD, SE	Yes

Table continuation

1	2	3	4	5	6	7
Package data transmission						
USE_GPRS_WHITE_LIST	-	BOOLEAN	FALSE	Parameter, that shows the necessity of using GPRS_WHITE_LIST during package data transmission	AD, SE	Yes
GPRS_WHITE_LIST	-	data format ³⁾	Empty list	List of networks in which package data transmission is permitted. If GPRS_WHITE_LIST list is empty, then package data transmission is forbidden	AD, SE	Yes

1	2	3	4	5	6	7
Test mode						
TEST_REGISTRATIO N_ PERIOD	Minutes	INT	5	If the In-Vehicle Emergency Call System/Device was registered in the network by pushing the “Additional functions” button then the following registration of the In-Vehicle Emergency Call System/Device by pushing the “Additional functions” button would be possible in an hour. If the value is set in “0” then there is no registration limit	AD, SE	Yes

Table continuation

1	2	3	4	5	6	7
Acceleration profile recording during road accident						
IGNITION_OFF_FOL LOW_UP_TIME1	Minutes	INT	120	Time interval when acceleration profile is recorded during road accident with ignition switched off.	AD	Yes
IGNITION_OFF_FOL LOW_UP_TIME2	Minutes	INT	240	Time interval for road accident detection with ignition switched off.	AD	Yes
CRASH_RECORD_TI ME	Millisecon ds	INT /0 – 250	250	Time of recording acceleration profile information during road accident	AD	Yes
CRASH_RECORD_ RESOLUTION	Milliseconds	INT /1 – 5	1	Discretization of acceleration profile information record	AD	Yes
CRASH_PRE_RECOR D_ TIME	Milliseconds	INT /0 – 20000	20000	Time of recording acceleration profile information before the road accident	AD	Yes
CRASH_PRE_RECOR D_ RESOLUTION	Milliseconds	INT / 5 – 100	5	Duration of one counting during recording of acceleration profile information before the road accident	AD	Yes

Table continuation

1	2	3	4	5	6	7
Other parameters						
GNSS_POWER_OFF_TIME	Milliseconds	INT	500	Time interval when global navigation satellite system receiver is switched off after the ignition stop.	Yes	Yes
GNSS_DATA_RATE	Hertz	INT / 1, 2, 5, 10	1	Data issue rate of global navigation satellite system receiver	AD, SE	No
GNSS_MIN_ELEVATION	Degrees	INT / 5 – 15	15	The value of minimum depression angle (extinction angle) of navigation spacecrafts	AD, SE	No
Vehicle parameters						
VIN	-	STRING	Is defined during the vehicle configuration	VIN is defined according to [1]	AD, SE	No
VEHICLE_TYPE	-	INT	-	Vehicle category Bit 4-0: 00001 – passenger (category M1) 00010 – bus (category M2) 00011 – bus (category M3) 00100 – light truck (category N1) 00101 – heavy truck category N2)	AD, SE	No
			-	00110 – heavy truck (category N3) 00111 – motorbike (category L1e)		

1	2	3	4	5	6	7
				01000 – motorbike (category L2e) 01001 – motorbike (category L3e) 01010 – motorbike (category L4e) 01011 – motorbike (category L5e) 01100 – motorbike (category L6e) 01101 – motorbike (category L7e)		
VEHICLE_PROPULSION_STORAGE_TYPE	-	INT	-	Power source type If all bits are «0», then the type is not set Bit 7: not used Bit 6: not used Bit 5: 1 – hydrogen Bit 4: 1 – electricity (not more 42 V and 100 A.h.) Bit 3 : 1 – liquid propane (LPG) Bit 2: 1 – liquefied natural gas (CNG) Bit 1: 1 – diesel Bit 0: 1 – gasoline	AD, SE	No

Table continuation

1	2	3	4	5	6	7
The In-Vehicle Emergency Call System/Device parameters						
SERIAL_NUMBER	-	STRING	-	Serial device number	-	No
HW_VERSION	-	STRING	-	Hardware version	-	No
SW_VERSION	-	STRING	-	Software version	-	No
VENDOR_ID	-	INT	-	The device providers identifier	-	No

1	2	3	4	5	6	7
UNIT_ID	-	INT	-	The unique device identifier, set by system operator during first activation	-	No
LANGUAGE_ID	-	INT	-	Preferable language for the voice communication 0x5F – Russian	-	No
<ul style="list-style-type: none"> • 1) Value «AD» means that, the corresponding parameter is obligatory only for in-vehicle emergency call system/device installed in configuration of additional equipment. Value «AD, SE» means that, the corresponding parameter is obligatory for both the in-vehicle emergency call system/device installed in configuration of additional equipment and for the in-vehicle emergency call system/device installed in configuration of standard equipment. • 2) Ranges (intervals) of parameters change according to parameter type: <ul style="list-style-type: none"> • - INT: 0 – 65535; • - BOOLEAN: TRUE, FALSE; • - STRING: 255 symbols. • 3) Data format – according to GOST R 54619. • 4) Value «YES» means that, the set value of the in-vehicle emergency call system/device initial parameter value may change after the initial installation of the in-vehicle emergency call system/device, and value «No» - that set initial parameters values are unchangeable in the process of the in-vehicle emergency call system/device use 						

1

Specifications for the data exchange protocol between an AECD and devices of the emergency response services infrastructure

1. Definitions

1 For the purposes of this Annex:

1.1 “*Minimum data set*” - A data set, sent by the in-vehicle emergency call system/device system in case of a road accident, which contains data concerning vehicle coordinates and movement of the vehicle, VIN-code and other information, required for emergency response.

1.2 “*Service*” - An element of the telematic platform infrastructure of the emergency response system, which provides for execution of this or that service algorithm, performed by the system using a service support protocol.

1.3 “*A Road Accident Emergency Response System*” – The automated navigation and information system functioning with use of signals of global navigation satellite system of standard accuracy, realizing delivery of messages on road accidents and other emergency situations on highways to emergency field services.

1.4 “*A Road Accident Emergency Response System Service*” - The result of functioning of the system, consisting in formation and transmission of emergency messages about road accidents, reception, processing and sending of the specified messages to a unified hotline monitoring service System-XXX and dispatching and ensuring establishment (commutation) of a bilateral voice communication with the persons being in the vehicle.

1.5 “*System-XXX*” – A system of providing an emergency call service according to uniform number “XXX”.

1.6 “*Uniform number XXX*” - It is a unified number for making a call to emergency services, established in the system and numbering plan.

1.7 “*A Road Accident Emergency Response System Operator*” - A legal entity, dealing with the system operation, including data processing from the system database.

1.8 The following symbols and abbreviations are applied:

VS	- In-vehicle emergency call system/device;
NIS	- navigation-information systems;
RAM	- random access memory;
SW	- software;
SSP	- service support protocol;
TP	- transport protocol;
TP	- telematic platform;
MV	- motor vehicle;
Digital signature	- data in e-form, used for data sender identification;
ERA	- emergency response to accidents;
CP-1251	- CodePage CP1251 (a set of symbols and an 8-bit coding, standard for all Russian versions of Microsoft Windows);
CRC-8(16)	- Cyclic Redundancy Code;
eCall	- Emergency Call (the all-European system of emergency response to accidents);
EGTS	- Era Glonass Telematics Standard (a telematic standard for Road Accident Emergency Response System);
FTP	File Transfer Protocol;
IP	- Internet Protocol;
GSM	- Global System for Mobile communications (global digital standard for mobile cellular communication);
HTTP	- Hypertext Transfer Protocol;

IMAP	- Internet Message Access Protocol;
ISDN	- Integrated Services Digital Network;
Little-endian	- least significant byte first (byte ordering);
NGTP	- Next Generation Telematics Protocol (Architecture and design concept);
OSI	- Open Systems Interconnection Basic Reference Model (abstract network model for communication and net protocols development);
PDU	- Protocol Description Unit;
POP3	- Post Office Protocol Version 3 ;
SC	- Service Centre (a service centre, responsible for SMS messages processing, storage and transfer to receivers);
SIM	- Subscriber Identification Module;
SME	- Short Message Entity (objects, that can receive and send SMS messages);
SMS	- Short Message Service;
SMSC	- Short Message Service Centre;

2. General principles

2.1 Open Systems Interconnection Network model in compliance with ISO/IEC 7498-1 specifies the following data exchange levels:

- physical;
- channel;
- network;
- transport;
- session;
- representation of data and applications.

2.2 In terms of OSI network model in a Road Accident Emergency Response System the following data transfer protocols are used between the in-vehicle emergency call system and a system operator:

- transport level - TCP protocol;
- network level - IP protocol.

Compliance of OSI network model, TCP/IP protocol stack and the Road Accident Emergency Response System data transfer protocols is given in Table 1.

Table 1 - Compliance of OSI model levels, TCP/IP protocol stack and the Road Accident Emergency Response System protocols

OSI model		TCP/IP protocol stack		TCP/IP protocols	Road Accident Emergency Response System protocols
Level number	Level	Level number	Level		
7	Applications	4	Applications	FTP, HTTP, POP3, IMAP, telnet, SMTP, DNS, TFTP	Service support level
6	Data representation				
5	Session				Transport level
4	Transport	3	Transport	TCP, UDP	TCP
3	Network	2	Internet	IP	IP
2	Channel	1	Network access		-
1	Physical				-

2.3 This Annex states requirements to the following protocols of data exchange between "Road Accident Emergency Response System system units:

- transport protocol;
- service support protocol, including a basic service, provided by the Road Accident Emergency Response System.

2.4 This Annex also specifies the requirements to AL-ACK message format, which is sent via an in-band modem [1].

3. Transport protocol

3.1 Transport protocol assignment

3.1.1 Transport protocol is meant for service support protocol data routing between items of the Road Accident Emergency Response System infrastructure and VS, using this protocol, integrity check-up and right data ordering, as well as for assurance of delivery reliability.

3.1.2 System structure principle description based on a transport level is given in Addendum A

3.1.3 Transport protocol analysis on NGTP concept basis is given in Addendum B

3.2 Routing provision

A transport protocol is based on a flexible data packet routing between interconnected units of the telematic platform distributed network, where this protocol is used. Telematic platform identifiers are used as routing addresses, therefore they should be unique within one interconnected network.

3.3 Data integrity checking mechanism

Transferred data integrity is controlled using check sums of the transport level header and service support level data. A recipient counts check sums and compares them with the corresponding values, put down into certain packet fields by the sender. If check sums differ, then integrity is broken, which is proved by the acknowledgement message with the processing result failure code.

In order to reduce at most the use of system resources while transport protocol packets and service support level data processing, various fields and algorithms of integrity control assurance are used. In this case a mechanism based on the transferred byte order check sum computation (CRC) is used.

CRC-8 cyclic redundancy code computation algorithm is used for a transport level packet.

CRC-16 cyclic redundancy code computation algorithm is used for a service support level packet.

3.4 Data batch delivery control

3.4.1 A reliable delivery control mechanism is based on the use of confirmations of previously sent batches. After the batch is sent, the sender waits for a confirmation in a certain kind of batch, which contains the identifier of previously sent batch and its processing result code on the receiving side. Waiting time is regulated by the transport protocol and depends on the type of the used low level transport protocol (TL_RESPONSE_TO parameter in Table 13). When confirmation is received, the sender performs the result code analysis.

Processing results codes are also regulated by the transport level protocol and given in Addendum B.

3.4.2 Depending on the analysis result, the batch is considered to be delivered or undelivered. A batch is regarded as undelivered, if confirmation is not received within TL_RESPONSE_TO time period (see Table 13). Undelivered batches are sent again (a number of trials is specified in the protocol and defined by TL_RESEND_ATTEMPTS parameter, given in Table 13). When the maximum sending trials number is reached, the data transfer channel is regarded as unreliable, and the session is deleted (if TCP/IP is used as a transport protocol, session is disconnected) and a new session (connection) can be established after the time period, defined by TL_RESPONSE_TO, is over (see Table 13).

3.5 Description of transport protocol data types

3.5.1 Transport protocol specifies and uses several different types of field data and variables. Structure and characteristic of data types, used in the transport protocol, are given in Table 2.

3.5.2 Multibyte data types - USHORT, UINT, ULONG, FLOAT and DOUBLE use little-endian (least significant byte first) byte ordering. Bytes, which compose ordering in STRING and BINARY types, should be interpreted as they are, i.e. they should be processed according to their order.

3.5.3 The following types of fields and parameters are specified in the transport protocol:

- M (mandatory) - an obligatory parameter. Parameter should be transferred every time;
- O (optional) - non-obligatory. The parameter transfer is optional and depends on other parameters, included into the batch.

Table 2 - Composition and description of data types, used in the transport protocol

Data type	Size, bytes	Value range	Description
BOOLEAN	1	TRUE-1, FALSE-0	A logical type, which receives only two values - TRUE or FALSE
BYTE	1	0 ... 255	Unsigned integer
USHORT	2	0 ... 65535	Unsigned integer
UINT	4	0 ... 4294967295	Unsigned integer
ULONG	8	0...18446744073709551615	Unsigned integer
SHORT	2	minus 32768 ... plus 32767	Signed integer
INT	4	minus 2147483648 ... plus 2147483647	Signed integer
FLOAT	4	$\pm 1.2 \text{ E} - 38 \dots 3.4 \text{ E} + 38$	Signed fraction
DOUBLE	8	$\pm 2.2 \text{ E} - 308 \dots 1.7 \text{ E} + 308$	Signed fraction
STRING	Variable. Size is defined by external parameters or application of a special terminator-symbol (0x00 code)	-	It contains a sequence of printed characters in CP-1251 coding by default, if other coding is not specified (using an optional parameter)
BINARY	Variable. Size is defined by external parameters	-	Contains BYTE data sequence
ARRAYOF TYPE	Variable. Size is defined by external parameters	-	It can include a sequence of one of the abovementioned types (TYPE), except BINARY. Byte ordering and a size of each unit of the used type depends on the type itself. Type examples are arranged in sequence. For instance: ARRAY OF STRING comprises 10 STRING specimens, and a size of each specimen is determined by a terminator (0x00 code), which can take place between specimens.

3.6 Description of transport protocol data structures

3.6.1 A transport protocol packet general structure is defined by the packet structure and its format.

3.6.1.1. The transport protocol packet consists of a header, a "service support data" field, and a "service support data" check sum field.

A transport protocol packet structure is given on diagram 1.



Diagram 1 - Transport protocol packet structure

3.6.1.2 Total length of transport protocol packet does not exceed 65535 byte, which corresponds to the Window Size parameter maximum value (a maximum size of a whole packet, which can be received by the receiver) of TCP protocol header. Such packet maximum size value allows to use data transfer channels more effectively, proceeding from a standard data flow control method, programmed in TCP/IP protocol [1].

A transport level packet format is given in Table 3.

Table 3 - A transport protocol packet composition

Bit 7	Bit 6	Bit 5	Bit 4	Bit 3	Bit 2	Bit 1	Bit 0	Type	Data type _x	Size, bytes
PRV (Protocol Version)								M	BYTE	1
SKID (Security Key ID)								M	BYTE	1
PRF (Prefix)	RTE	ENA		CMP	PR			M	BYTE	1
HL (Header Length)								M	BYTE	1
HE (Header Encoding)								M	BYTE	1
FDL (Frame Data Length)								M	USHORT	2
PID (Packet Identifier)								M	USHORT	2
PT (Packet Type)								M	BYTE	1
PRA (Peer Address)								O	USHORT	2
RCA (Recipient Address)								O	USHORT	2
TTL (Time To Live)								O	BYTE	1
HCS (Header Check Sum)								M	BYTE	1
SFRD (Services Frame Data)								O	BINARY	0 ... 65517
SFRD (Services Frame Data)								O	USHORT	0, 2

3.6.1.3 Transport protocol header consists of the following parameters (fields): PRV, PRF, PR, CMP, ENA, RTE, HL, HE, FDL, PID, PT, PRA, RCA, TTL, HCS. A service support protocol is presented with SRD field, a service support field check sum is in SFRCS field.

Description of the abovementioned parameters (fields) is provided in Table 4.

Table 4 - A transport protocol packet parameters (fields) description

Parameter (field) identifier	Parameter (field) assignment
PRV	A version of the used header structure is determined by the parameter which should hold a value of 0x01. This parameter value is incremented every time, when the header structure is changed.
SKID	Parameter defines a key identifier, used for coding.
PRF	A transport level header prefix is determined by the parameter, which should hold a value of 00.
RTE (Route)	A bit field that designates the necessity of further routing of a given packet to a remote telematic platform, as well as presence of optional parameters PRA, RCA, TTL required for packet routing. If this field has a value of 1, then routing is required, and the packet contains PRA, RCA and TTL fields. This field's value is set up by a dispatch operator of the telematic platform, on which the packet was generated, or the VS that generated the packet for transmission to a telematic platform, if this VS has the "HOME_DISPATCHER_ID" parameter set up to define its registration address. If HOME_DISPATCHER_ID of the terminal is not defined, the packet is routed in accordance with the internal rules of the Dispatch Operator responsible for processing of this packet.
ENA (Encryption Algorithm)	A bit field determines the algorithm code, used for SFRD field data coding. If the field value is 0 0, then SFRD field data are not coded. Structure and codes of algorithms are not determined in this protocol version.
CMP (Compressed)	A bit field determines, whether SFRD field data are compressed. If the field value is 1, then SFRD field data are compressed. Compression algorithm is not defined in this protocol version.
PR (Priority)	A bit field defines the packet routing priority and can take the following values: 00 - higher; 01 - high; 10 - medium; 11 - low. A higher priority setup allows sending of Expedited data packets, such as a minimum data set of the "ERA-GLONASS" basic service or the in-vehicle alarm activation data. When the packet is received by the dispatch operator, speed of packet analysis and routing depends on its priority: the higher priority packet processing is performed quicker, when particularly important events take place.
HL	A transport protocol header length in bytes considering the check sum byte (HCS field).
HE	Defines the encoding method used to encode the part of a transport protocol header that follows this parameter (reserved.)
FDL	Determines a size of SFRD data field in bytes, which comprises the service support protocol data.

Table 4 continued

Parameter (field) identifier	Parameter (field) assignment
PID	Contains a transport protocol packet number, which increases by one every time a new packet is sent on the sender's side. Values in this field change in compliance with the circular counter rules in a range of 0 to 65535, thus, when 65535 is reached, the next value should be 0.
PT	A type of the transport protocol packet. PT field can take the following values: 0 - EGTS PT RESPONSE (confirmation of the transport protocol); 1 - EGTS PT APPDATA (packet, that contains the service support protocol data); 2 - EGTS_PT_SIGNED_APPDATA (a packet, that contains data of the service support protocol with a digital signature).
PRA	Address of the telematic platform, where the packet is generated. This address is unique in terms of the connected net and used for confirmation packet building on receiving side.
RCA	Address of the telematic platform, the packet is intended for. This address is used for packet appurtenance identification to a certain telematic platform and its routing, using transient telematic platforms.
TTL	Packet life duration while routing between telematic platforms. Use of this parameter prevents packet circling during retransmission in systems with a complex topology of address points. Primarily, TTL is set up by the telematic platform, which generated this packet. TTL value is set to a telematic platform maximum allowable value between sending and receiving platforms. TTL value decreases by one during transmission of the packet via each telematic platform, and a transport protocol header check sum is calculated. When the parameter reaches 0, and further packet routing is needed, the packet is eliminated, and the confirmation of this event with the corresponding code (PC TTLEXPRIED, see Appendix C) is delivered.
HCS	The transport protocol header check sum (starting from PRV field to HCS field, excluding the latter one). In order to calculate HCS field value a CRC-8 algorithm is applied to all bytes of the specified sequence. An example of the calculation program code CRC-8 is given in Appendix D.
SFRD	Data structure, which depends on the type of packet and contains a service support protocol data.
SFRCS	Check sum. In order to calculate a check sum, using SFRD field data a CRC16 -CCITT algorithm is used. This field is present only if there is SFRD field. An example of CRC-16 program calculation code is given in Appendix D.

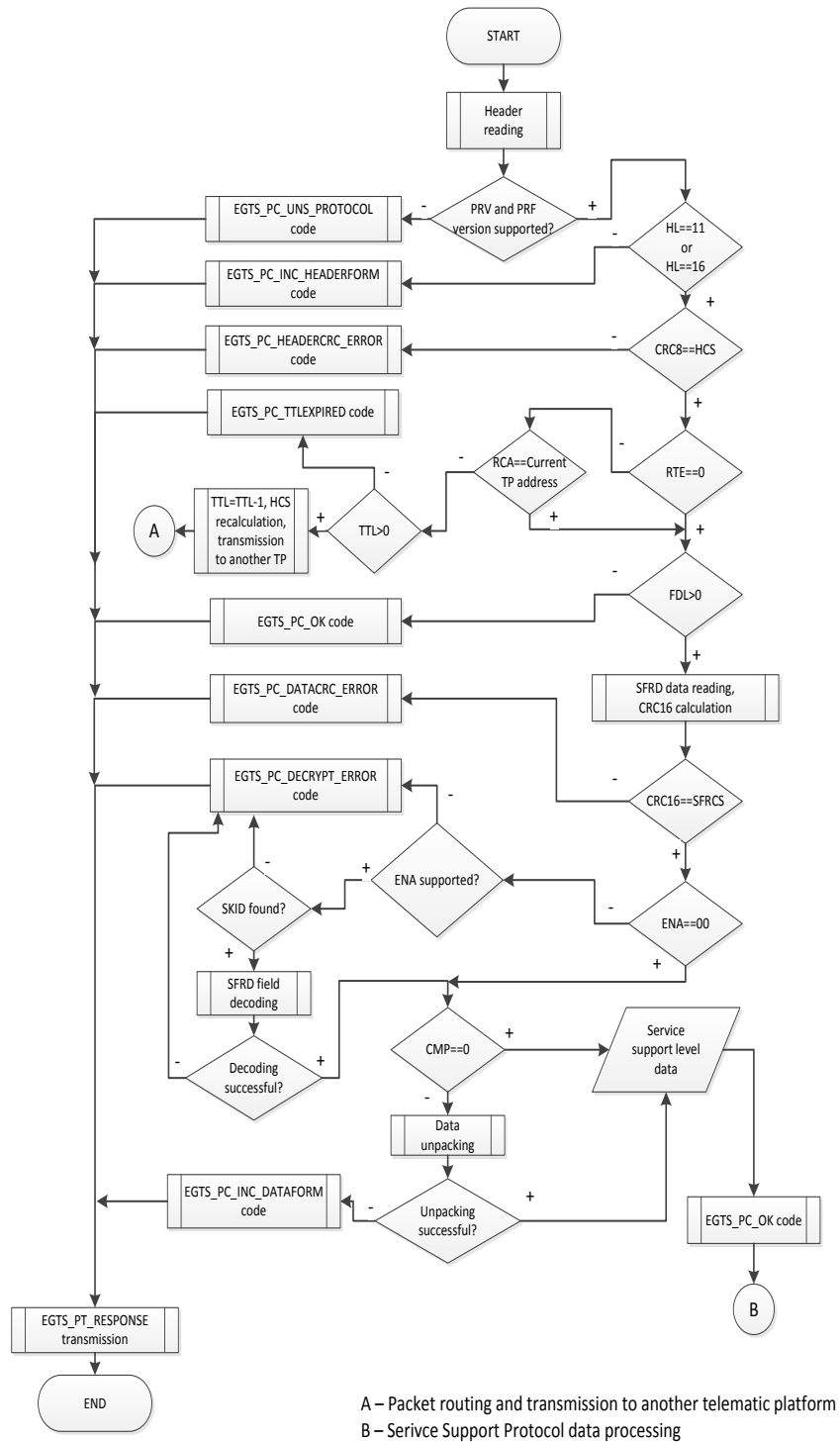

Figure 1 - Assembly algorithm for Rx transport protocol packets

3.6.2 Data structures in relation to the packet type

Depending on the transport protocol packet type, SFRD field structure has a different format.

3.6.2.1 EGTS_PT_APPDATA packet data structure

This type of packet is designed for transmission of one or several structures, which contain the service support protocol data. The SFRD field data structure of EGTS_PT_APPDATA packet is given in Table 5.

Table 5 - SFRD field format for the packet of EGTSPTAPPDATA type

Bit 7	Bit 6	Bit 5	Bit 4	Bit 3	Bit 2	Bit 1	Bit 0	Type	Data type	Size, bytes
SDR 1(Service Data Record)								O	BINARY	9 ... 65517
SDR 2								O	BINARY	9 ... 65517
SDRn								O	BINARY	9 ... 65517
Note - SDR 1, SDR 2, and SDRn structures contain the service support protocol data. SFRD field can contain one or several sequential structures of this kind. Description of the structures' internal composition is given in Section 6.										

3.6.2.2 EGTS_PT_RESPONSE packet data structure. This type of packet is used for confirmation of the transport protocol packet. This type of packet contains data on the transport protocol data processing result, received before. The SFRD field data structure of EGTS_PT_RESPONSE packet is given in Table 6.

Table 6 - SFRD field format for the packet of EGTS_PT_RESPONSE type

Bit 7	Bit 6	Bit 5	Bit 4	Bit 3	Bit 2	Bit 1	Bit 0	Type	Data type	Size, bytes
RPID (Response Packet ID)								M	USHORT	2
PR (Processing Result)								M	BYTE	1
SDR 1(Service Data Record)								O	BINARY	9... 65517
SDR 2								O	BINARY	9... 65517
SDRn								O	BINARY	9... 65517
Notes: 1 RPID parameter is used as a transport level packet identifier, being confirmed. 2 PR parameter is a code of the packet transport level part processing result (calculation of the transport level header check sums and a service support level data, packet size check-up, need in further packet routing is determined, etc.). A list of possible processing result codes is given in Appendix C. 3 SDR 1, SDR 2, and SDRn are the structures, which contain the service support level data. There can be one or several sequential structures of the kind.										

3.6.2.3 EGTS_PT_SIGNED_APPDATA packet data structure

This packet type is used for transmission of both the service support data structures and a digital signature data, which identifies the sender.

SFRD field data structure of EGTS_PT_SIGNED_APPDATA packet

is given in Table 7.

Table 7 - SFRD field format for EGTS_PT_SIGNED_APPDATA packet

Bit 7	Bit 6	Bit 5	Bit 4	Bit 3	Bit 2	Bit 1	Bit 0	Type	Data type	Size, bytes
SIGL(Signature Length)								M	SHORT	2
SIGD(Signature Data)								O	BINARY	0 ... 512
SDR 1(Service Data Record)								O	BINARY	9... 65515
SDR 2								O	BINARY	9... 65515
...							
SDRn								O	BINARY	9... 65515

Notes:

1 SIGL parameter determines a "digital signature" data length in SIGD field

2 SIGD parameter contains the digital signature" data itself.

3 SDR 1, SDR 2, and SDRn are the structures, which contain the service support level data. There can be one or several sequential structures of the kind.

3.6.2.4 A packet of EGTS_PT_RESPONSE type, which contains EGTSPTAPPDATA or EGTS_PT_SIGNED_APPDATA packet number in the PID field, should be sent per each delivered packet of EGTSPTAPPDATA or EGTS_PT_SIGNED_APPDATA type, sent by VS to the telematic platform, or from the telematic platform to VS.

Packets exchange sequence is given on Figure 2, considering a cooperation of VS and a telematic platform.

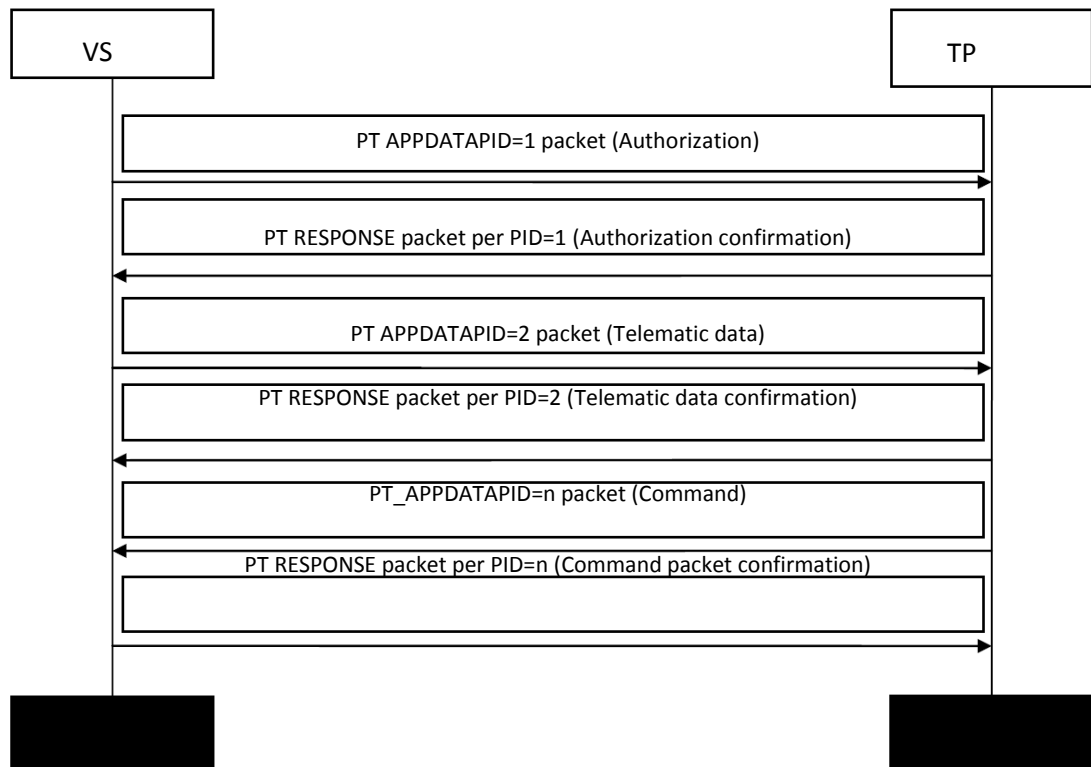

Figure 2 - VS and a telematic platform cooperation in terms of the transport level packets

3.7 Data structure description when SMS is used as a standby data sending channel

3.7.1 SMS structure

When sending transport protocol data packets via SMS, a PDU [2],[3] mode is used. A PDU mode allows to send both text and binary data via SMS service of GSM network operator. The described transport protocol uses binary data, therefore a PDU mode suits best when using SMS as a standby channel for transport level data sending.

3.7.1.1 For SMS message transmission an 8 bit coding is used. SMS format for sending in a PDU mode is presented in Table 8, it uses a structure, described in [3 (section 9)].

Table 8 - SMS format using a PDU mode

Bit 7	Bit 6	Bit 5	Bit 4	Bit 3	Bit 2	Bit 1	Bit 0	Type	Size, bytes
SMSCAL (SMSC Address Length)								M	1
SMSCAT (SMSC Address Type)								O	0,1
SMSC_A(SMSC Address)								O	0,6
TP_RP	TPUDHI	TP_SRR	TP_VPF	TP_RD	TP_MTI			M	1
TP_MR (Message Reference)								M	1
TP_DA_L (Destination Address Length)								M	1
TP_DA_T (Destination Address Type)								M	1
TP_DA(Destination Address)								M	6
TPPID (ProtocolIdentifier)								M	1
TPDCS (Data Coding Schema)								M	1
TP_VP (ValidityPeriod)								O	0, 1, 7
TPUDL (User Data Length)								M	1
TPUD (UserData)								O	0...140

3.7.1.2 Description of SMS message parameters in the PDU mode is provided below:

- SMSCAL is a SMSC address useful data length in octet bytes;
- SMSCAT is a type of SMSC address format.

Possible values of SMSCAT parameters are given in Table 10. The field is optional, its presence depends on SMSC_AL parameter value (if the SMSCAL value is larger than 0, this field is present);

- SMSCA is a SMSC address. Each decimal digit of the code is shown as four bits (4 low bits is a higher class digit, 4 high bits is a lower class digit), and if a digit number in a code is uneven, then bits from 4 to 7 of the code last byte are set to 0xF (1111b). This parameter is optional and their presence depends on SMSC_AL parameter value. If there is no SMSC_A parameter, then SMSC from the SIM-card is used;

- TP_MTI - (Message Type Indicator) message type (should contain a binary value of 01);

- TP_RD - (Reject Duplicates) a field, which determines the need in the message processing by SMSC, in case there is the previous non-processed message, sent from this number, which has the same value in a TP_MR field and the same receiver's number in TP_DA field;

- TP_VPF - (Validity Period Format) TP_VP parameter format. Possible values of TP_VPF field are given in Table 9;

- TP_SRR - (Status Report Request) Need in confirmation sending from SMSC side in response to this message is determined by this field (if the bit is set to 1, confirmation is required);

- TPUDHI - (User Data Header Indicator) the field defines, whether the TP_UD_HEADER user data header is transmitted (if the field is set to 1, then the header is present);

- TP_RP - (Reply Path) the field determines, whether an RP field is present in a message;

- TP_MR is a message identifier (should increase by 1 every time a new message is sent);

- TP_DA_L is a receiver's address useful data length in octet bytes;

- TP_DA_T is a type of receiver's address format. Probable values of TP_DA_T and SMSCAT parameters are given in Table 10;

- TP_DA is a receiver's address. A number coding is performed according to the same rules that for SMSC_A parameter;

- TP_PID is a protocol identifier (must comprise 00);

- TPDCS is a type of data coding (should contain 0x04, it determines an 8-bit message coding, no compression);

- TP_VP is a time of actuality of this message. This field format is determined by a value from Table 9. The parameter is optional. Its presence and size depend on a value in a TP_VPF field;

- TP_UDL is a length of message data in a TP_DL field in bytes for the 8-bit coding used;

- TP_UD are transmitted user data. A format of this field depending on the value in a TP_UDHI field is given in Table 11.

Table 9 - A TPVP field format in relation to the value in a TPVPF field

Bit value		Description
0	0	TP VP field is not transmitted
1	0	TP VP field has a "relative time" format, its size is 1 byte
0	1	TP VP field has an "expanded time" format, its size is 7 byte
1	1	TP VP field has an "absolute time" format, its size is 7 byte

Table 10 TP_DA_T and SMSCAT format (address type)

Bit 7	Bit 6	Bit 5	Bit 4	Bit 3	Bit 2	Bit 1	Bit 0	Size, bytes
1	TON			NPI				1

Parameters of TP_DA_T and SMSC_AT fields, given in Table 10, have the following assignment:

- TON (Type Of Number) - type of number. TON parameter can take the following values:

- a) 000 - unknown;
 - b) 001 - international format;
 - c) 010 - national format;
 - d) 011 - a special net-defined number;
 - e) 100 - subscriber's number;
 - f) 101 - an alphanumeric code (codes according to [2] with a 7-bit coding by default);
 - g) 110 - shortened; h) 111 - reserved.
- NPI (NumericPlanIdentification) - a numeration plan type (applicable for TON - 000,001,010 field values). NPI can take the following values:

- a) 0000 - unknown;
- b) 0001 - ISDN telephony numeration plan;
- c) 0011 - a numeration plan while data transmission;
- d) 0100 - telegraph;
- e) 1000 - national;
- f) 1 001 - private;
- g) 1111 - reserved.

Table 11 - TPUD field format

Bit 7	Bit 6	Bit 5	Bit 4	Bit 3	Bit 2	Bit 1	Bit 0	Type	Size, bytes
LUDH (Length of User Data Header)								O	1
IEI "A" (Information-Element-Identifier «A»)								O	1
LIE "A" (Length of Information-Element «A»)								O	1
IED "A" (Information-Element-Data of «A»)								O	1 ... n
IEI "B" (Information-Element-Identifier «B»)								O	1
LIE "B" (Length of Information-Element «B»)								O	1
IED "B" (Information-Element-Data of «B»)								O	1 ... n
IEI "N" (Information-Element-Identifier «N»)								O	1
LIE "N" (Length of Information-Element «N»)								O	1
IED "N" (Information-Element-Data of «N»)								O	1 ... n
UD (User Data)								M	1...140

Parameters of TP_UD, given in Table 11, have the following assignment:

-LUDH is a length of user data header in bytes excluding the field size;

-IEI "A", IEI «B» , IEI «N» is an identifier of "A", "B" and "N" data element, respectively, which defines a type of data element and can take the following values (in a hexadecimal system):

- a) 00 is a part of concatenated SMS message;
- b) 01 is a special SMS message indicator;
- c) 02 is reserved;
- d) 03 is not used;
- e) 04 - 7F is reserved;
- f) 80 - 9F- for special SME use;
- g) A0 - BF is reserved;
- h) C0 - DF is for special SC use;
- i) E0 - FF is reserved.

-LIE "A", LIE "B" , LIE "N" are parameters which determine a size of "A", "B" and "N" information elements data, respectively, in bytes, excluding the field size;

-IED "A", IED "B" , IED "N" are data of "A", "B" and "N" information elements, respectively;

-UD - user data. The field size is determined by presence of TP_UD_HEADER user data header, which consists of LUDH, IEI, LIE, IED fields. If the header is not transmitted, then a size is equal to a TPUDL field value, specified in Table 8. If the header is transmitted, then a field size is calculated as a difference (TP_UDL - LUDH -1).

If an IEI data element identifier of the TP_UD_HEADER user data header is 0, then an IED field structure will take the form as it is given in Table 12.

Table 12 - A data field format of information element, which characterizes a part of concatenated SMS message

Bit 7	Bit 6	Bit 5	Bit 4	Bit 3	Bit 2	Bit 1	Bit 0	Type	Size, bytes
CSMRN (Concatenated Short Message Reference Number)								M	1
MNSM (Maximum Number of Short Messages)								M	1
SNCSM (Sequence Number of Current Short Message)								M	1
Notes:									
1. CSMRN is a number of concatenated SMS message, which should have equal values for all parts of a long SMS message.									
2. MNSM is a total number of messages, a long SMS consists of. Value range should be from 1 to 255.									
3. SNCSM is a number of the transmitted part of long SMS. It is incremented every time a new part of a long message is sent. It should contain a value in a range from 1 to 255. If a value in this field exceeds a MNSM field value or is zero, then a receiving side should ignore the whole data element.									

3.7.2 Description of the transmitted data format

3.7.2.1 When using SMS for data exchange between a VS and a telematic platform, packets assembled in accordance with the rules of the transport protocol and the service support protocol are written into a TP_UD field (see Table 8). The total packet size should not exceed 140 bytes. In this case, no authorization mechanism is used, and no transport protocol confirmations in form of EGTS_PT_RESPONSE type packets or service support protocol confirmations in form of EGTS_SR_RECORD_RESPONSE subrecords are required. An SMS delivery report is considered a confirmation of successful packet transmission.

3.7.2.2 In order to send SMS with a "digital signature", a transport level packet of EGTS_PT_SIGNED_APPDATA type is used.

3.7.2.3 If a protocol data packet size is over 140 byte, a concatenation mechanism of SMS messages is used, it is specified in standard [3], (9.2.3.24.1)]. This mechanism is based on splitting transmitted user data into parts and delivery in separate SMS messages. Upon that every message of this type has a special structure, which determines a total number of parts of transmitted data and their assembly ordering on a receiving side. A TP_UD_HEADER, which contains an information element, characterizing a part of concatenated SMS message, is used as such structure. Thus, proceeding from a size of user data header size and a maximum number of a long message parts, which is 255, a maximum allowable packet size can comprise $255 \cdot (140 - 6) = 34170$ byte, if 8-bit coding is used.

3.8 Time and quantitative variables of the transport protocol when using a data batch sending method

Designation and description of time and quantitative variables of the transport protocol are specified in Table 13.

Table 13 - Time and quantitative parameters of a transport protocol

Name	Data type	Value range	Default value	Description
TL RESPONSE TO	BYTE	0 ... 255	5	Waiting period of packet confirmation at a transport level, in seconds
TL RESEND ATTEMPTS	BYTE	0 ... 255	3	A number of retries of a non-confirmed packet delivery
TL RECONNECT T O	BYTE	0 ... 255	30	A period from link breaking till another try of communication channel reestablishment.

4 Service support protocol (general part)

4.1 Service support protocol assignment

4.1.1 A service support protocol is intended for data exchange between ERA system elements, providing for system operation and rendering information services to consumers. Each service coincides with an individual key element of the system, build up on a service support protocol base.

4.1.2 A service support protocol performs the following key functions:

- exchange of informative messages, containing data to be processed by different services, and information release requests;
- assurance of service support data delivery and processing confirmation;
- identification of data belonging to a certain type of service;
- data characteristics determination (a number, a type, a composition, a size, coding, etc.)

4.2 Informative messages exchange

A service support protocol key structure, which contains all necessary data for information processing or any service request, is recording. Each record can consists of several subrecords, which comprise the necessary data and determine actions, performed by the subrecord processing service.

4.3 Assurance of a confirmation on service support data delivery and processing results

In terms of the service support level a sender's notification on data delivery and processing results is ensured by the informative record confirmation mechanism, which uses special subrecords where a received/processed record identifier is stored.

4.4 Identification of service support protocol data belonging

For identification of the record belonging to this or that service, an identifier of the service, which determines functional peculiarities and characteristics of the processed data, is used. Type of service is its identifier while routing inside the platform, which is unique in terms of the service support protocol.

4.5 Data characterization in the service support protocol

Data in a service support protocol are recorded as a subrecord, which has its own unique identifier in terms of a certain service type, and a strictly specified data organization design, which depends on the subrecord. Use of such data organization in a service support protocol allows to determine a precise data type, their physical meaning, a size and packing method.

4.6 Data structures, used in the service support protocol

4.6.1 A common structure

A transport protocol packet comprises a common service support protocol structure, consisting of one or several sequential records, that have different data structures, intended for different services. A common data structure is provided on chart 2.

Service support level data			
Record RID=1	Record RID=2		Record RID=N

Chart 2 - A common structure of the service support level data

4.6.2 An individual record structure

4.6.2.1 Record content an individual record of the service support protocol consists of a record header and record data. An individual record structure is given on Chart 3

Record header	Record data		
	Subrecord 1		Subrecord N

Chart 3 - An individual service support level record content

A record header comprises parameters, which determine types of sender's and receiver's services, a record identifier, an object identifier (e.g. VS), transmitted data length, and different flags, defining optional parameters use and a processing method.

Record data can contain one or several subrecords, which determine types and contain the transmitted data.

4.6.2.2 Record structure

An individual service support record structure is provided in Table 14.

Table 14 - A format of an individual service support protocol record

Bit 7	Bit 6	Bit 5	Bit 4	Bit 3	Bit 2	Bit 1	Bit 0	Type	Data type	Size, bytes
RL (Record Length)								M	USHORT	2
RN (Record Number)								M	USHORT	2
RFL (Record Flags)								M	BYTE	1
SSOD	RSOD	GRP	RPP	TMFE	EVFE	OBFE				
OID (Object Identifier)								O	UINT	4
EVID (Event Identifier)								O	UINT	4
TM (Time)								O	UINT	4
SST (Source Service Type)								M	BYTE	1
RST (Recipient Service Type)								M	BYTE	1
RD (Record Data)								M	BINARY	3...65498

Parameters of an individual service support protocol record, given in Table 14, have the following assignment:

- RL - the parameter determines RD field data size;
 - RN is a record number. Values in this field change in compliance with the circular counter rules in a range of 0 to 65535, thus, when 65535 is reached, the next value should be 0. A value in this field is used for record confirmation;
 - RFL comprises bit flags, which determine the use of OID, EVID and TM fields for record data characterization
- SSOD - (Source Service On Device), a bit flag, defining a sending service location:
- a) 1 - sending service is located on VS side;
 - b) 0 - sending service is located on a telematic platform;
- RSOD - (Recipient Service On Device), a bit flag, defining a receiving service location:
- a) 1 - receiving service is located on VS side;
 - b) 0 - receiving service is located on a telematic platform.
- GRP - (Group), a bit flag, which determines belonging of transmitted data to a certain group, whereas the group identifier is specified in OID field:
- a) 1 - data are intended for the group;
 - b) 0 - belonging to no group.
- RPP - (Record Processing Priority), a bit field, which determines the priority of the record processing by the service:
- a) 00 - the highest;
 - b) 01 - high;
 - c) 10 - medium;
 - d) 11 - low.
- TMFE - (Time Field Exists), a bit field, which determines a TM field presence in this field:
- a) 1 - TM field is present;
 - b) 0 - no TM field.

- EVFE - (Event ID Field Exists), a bit field, which determines an EVID field presence in this packet:

- a) 1 - EVID field is present;
- b) 0 - no EVID field.

- OBFE - (Object ID Field Exists), a bit field, which determines an OID field presence in this packet:

- a) 1 - OID field is present;
- b) 0 - no OID field.

- OID identifies an object, that generated this record, or this record is intended for (a unique VS identifier), or is used as a group identifier (at GRP=1). When VS transmits several records from one object for different services in one transport level packet, the OID field can be present in one record only, but be omitted in the following records;

- EVID is a unique event identifier. EVID field sets up a global event identifier, it is applied when a set of several informative essences should be logically linked with the only event, and these essences can be distributed into various data packets, and transmitted in different time periods. Whereas an application

software can unite all these essences into one at that moment a user receives information about the event. For example, if a picture series is associated with the alarm button pushing, EVID field should be specified in each service record, relative to this event during transmission of all essences, concerned with this event, no matter how much time takes transmission of the whole information pool;

- TM is time of record formation on sender's side (seconds since 00:00:00 01.01.2010 UTC). If several records associated with one object and one time period are transmitted in one transport level packet, then a TM, time mark field, can be sent in the first record only;

- SST is an identifier, a type of sending service, that generated this record. For example, a service, processing navigation data on VS side, a command service on the telematic platform's side, etc.;

- RST is an identifier, a type of service, that receives this record. For example, a service, processing navigation data on the telematic platform side, a command processing service on VS side, etc.;

- RD is a field, containing specific data for special types of service (one or several subrecords of the service type, specified in SST or RST field, depending on the kind of transmitted data).

4.6.3 General subrecord structure

A format of an individual subrecord in a service support protocol is given in Table 15.

Table 15 - A format of an individual service support protocol subrecord

Bit 7	Bit 6	Bit 5	Bit 4	Bit 3	Bit 2	Bit 1	Bit 0	Type	Data type	Size, bytes
SRT (Subrecord Type)								M	BYTE	1
SRL (Subrecord Length)								M	USHORT	2
SRD (Subrecord Data)								O	BINARY	0... 65495
<p>Notes:</p> <p>1 SRT is a subrecord type (a subtype of transmitted data in terms of the general set of types for one service). Type 0 is peculiar, it is reserved for data confirmation subrecord for each service. Precise numbers of subrecord types are defined by the service logic. The protocol specifies only the necessity of this number, and a zero identifier is reserved.</p> <p>2 SRL is a subrecord data length in bytes in SRD field.</p> <p>3 SRD is subrecord data. This field is filled up according to a combination of a service identifier and a subrecord type.</p>										

4.6.4 A confirmation with a subrecord data on the confirmed record identifier and result of its processing should be sent per each data record of the service support level. A diagram, which explains a confirmation mechanism operation during message exchange at a service support level, is given on Figure 3.

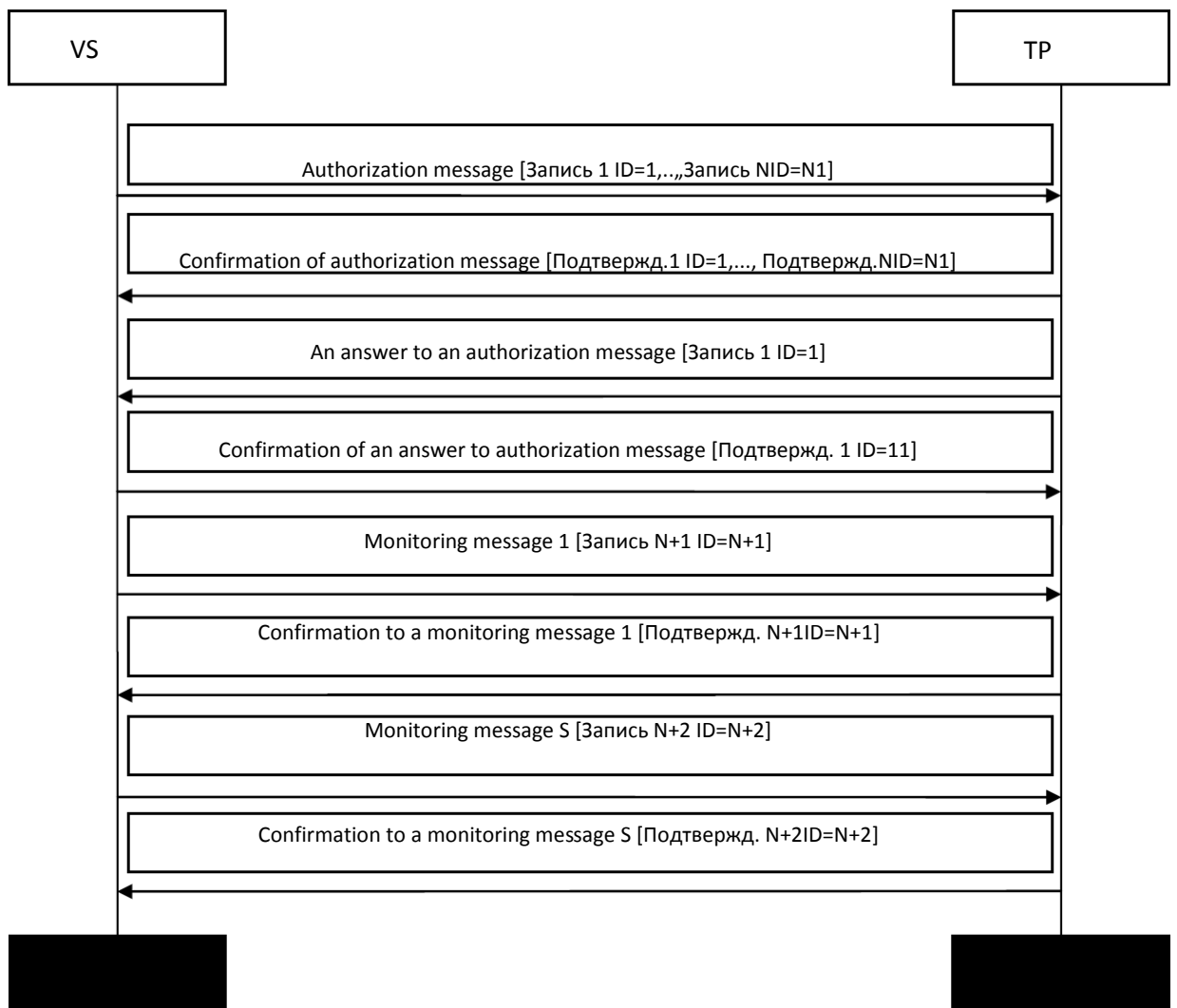

Figure 3 - Message exchange chart

Each service support protocol; message has a header and a transport level check sum, and also several service support level records. One message can contain both, information records and confirmations to the records received before.

4.7 Service delivery characteristic

4.7.1 A list of services, supported by the service support protocol, their decimal identifiers and description are provided in Table 16.

Table 16 - A list of services, supported by the protocol

Code	Name	Description	ДО ¹	ШСЭ ²⁾	ШСД ³⁾
1	EGTS_AUTH_SERVICE	This type of service is applied for VS authentication on a telematic platform. If TCP/IP protocol is used, then VS should pass this procedure, and a further interaction is possible only after successful completion of the procedure.	+	-	+
2	EGTS_TELEDATA_SERVICE	The service is intended for processing the telematic information (coordinate data, data on sensors actuation, etc.), delivered from VS.	+	-	+
4	EGTS_COMMANDS_SERVICE	This type of service is aimed at processing the control and configuration commands, data messages and statuses, transmitted between VS, a telematic platform and operators.	+	+	+
9	EGTS_FIRMWARE_SERVICE	The service is intended for transmission of configuration and software of VS hardware, and various peripheral equipment, connected to VS and supporting a remote software update	+	+	+
10	EGTS_ECALL_SERVICE	Service, that ensures ERA function fulfilment. The service description is given in section 7.	+	+	+

Note - VS configuration variants:
 1 VS, made in a supplementary equipment configuration;
 2 VS, made as standard equipment and intended for basic service performance by ERA system;
 3 VS, made as standard equipment and intended for optional services performance by ERA system, excluding a basic service;

4.7.2 EGTS_AUTH_SERVICE service

EGTS_AUTH_SERVICE service is applied for VS authentication on a telematic platform side and for receiving VS registration data and VS infrastructure data (content and versions of modules, units, peripheral equipment software and data about the vehicle). The service should be used by VS only when TCP/IP protocol is used, and every time a new linkage with the telematic platform is established.

Requirements of this standard item are only spread on VS in a supplementary equipment configuration, and cannot be applied to standard VS, which support only a basic accident response service.

A list of subrecords, used by EGTS_AUTH_SERVICE service, is given in Table 17.

Table 17 - A list of subrecords of EGTS_AUTH_SERVICE service

Code	Name	Description
0	EGTS_SR_RECORD_RESPONSE	A subrecord is applied only to confirm a service support protocol record processing. This type of subrecord should be supported by all services.
1	EGTS_SR_TERM_IDENTITY	A subrecord is used by VS in case of request for the telematic platform authorization and contains VS registration data.
2	EGTS_SR_MODULE_DATA	A subrecord is intended for transmission of VS infrastructure data, VS modules and units structure, state and parameters to the telematic platform. This subrecord is optional, and a decision on fields filling and subrecord sending necessity can be made by VS designer. One subrecord contains a description of one module. One record can sequentially transmit several subrecords of the kind, which ensures data transmission on individual components of all VS and peripheral equipment hardware.
3	EGTS_SR_VEHICLE_DATA	VS applies a subrecord for vehicle data transmission to the telematic platform.
64	EGTS_SR_AUTH_PARAMS	A subrecord used by a telematic platform to transmit encoding method/parameter data required for further communication.
7	EGTS_SR_AUTH_INFO	The subrecord is intended for transmission of VS authentication data to the telematic platform, using previously transmitted parameters for data coding.
8	EGTS_SR_SERVICE_INFO	This type of subrecord is used for informing a receiving side, VS or the telematic platform, depending on delivery direction, about supported services, and for request of a certain set of required services (from VS to TP).
9	EGTS_SR_RESULT_CODE	A subrecord is applied by the telematic platform for VS informing about VS authentication procedure results.

4.7.2.1 EGTS_SR_RECORD_RESPONSE subrecord. A subrecord structure is given in Table 18.

Table 18 - EGTS_SR_RECORD_RESPONSE subrecord format

Bit 7	Bit 6	Bit 5	Bit 4	Bit 3	Bit 2	Bit 1	Bit 0	Type	Data type	Size, bytes
CRN (ConfirmedRecordNumber)								M	USHORT	2
RST (Record Status)								M	BYTE	1

EGTS_SR_RECORD_RESPONSE subrecord fields have the following assignment:

- CRN is a confirmed record number (meaning of RN field from the processed record);
- RST is a record processing status.

After receiving confirmation the sender analyses RST field of EGTS_SR_RECORD_RESPONSE subrecord. If the successful processing status is received, the sender eliminates a record from the internal storage, in case of a fault and according to its reason the appropriate measures are performed.

4.7.2.2 EGT S_SR_TERM_IDENTITY subrecord.

A subrecord structure is given in Table 19.

Table 19 - A format of EGTS_AUTH_SERVICE service EGTS_SR_TERM_IDENTITY subrecord

Bit 7	Bit 6	Bit 5	Bit 4	Bit 3	Bit 2	Bit 1	Bit 0	Type	Data type	Size, bytes
TID (TerminalIdentifier)								M	UINT	4
Flags								M	BYTE	1
MNE	BSE	NIDE	SSRA	LNGCE	IMSIE	IMEIE	HDIDE			
HDID (Home Dispatcher Identifier)								O	USHORT	2
IMEI (International Mobile Equipment Identity)								O	STRING	15
IMSI (International Mobile Subscriber Identity)								O	STRING	16
LNGC (Language Code)								O	STRING	3
NID (Network Identifier)								O	BINARY	3
BS (Buffer Size)								O	USHORT	2
MSISDN (Mobile Station Integrated Services Digital Network Number)								O	STRING	15

EGTS_SR_TERM_IDENTITY subrecord fields have the following assignment:

- TID – is a unique identifier assigned during VS programming. If this field has a value of 0, it means that a VS is not configured, or its configuration is not complete. This identifier is assigned by an ERA-GLONASS system operator and expressly defines a VS's registration dataset. If a VS is installed as supplementary equipment, it is assigned a unique TID value after its registration data (IMSI, IMEI, serial_id) is sent to an operator. If a VS is used as part of a standard equipment configuration, its unique TID value is sent to an operator by the vehicle manufacturer along with its registration data (VIN, IMSI, IMEI);
- HDIDE is a bit flag, defining HDID field presence in a subrecord (if a bit value is 1, then a field is transmitted, if 0, it is not transmitted);
- IMEIE is a bit flag, defining IMEI field presence in a subrecord (if a bit value is 1, then a field is transmitted, if 0, it is not transmitted);
- IMSIE is a bit flag, defining IMSI field presence in a subrecord (if a bit value is 1, then a field is transmitted, if 0, it is not transmitted);
- LNGCE is a bit flag, defining LNGC field presence in a subrecord (if a bit value is 1, then a field is transmitted, if 0, it is not transmitted);

- SSRA -is a bit flag, used to define a service use algorithm (if a bit value is 1, then a "simple" algorithm is used, if 0, then a "request" algorithm for service use is applied);
- NIDE is a bit flag, defining NID field presence in a subrecord (if a bit value is 1, then a field is transmitted, if 0, it is not transmitted);
- BSE is a bit flag, defining BS field presence in a subrecord (if a bit value is 1, then a field is transmitted, if 0, it is not transmitted);
- MNE is a bit flag, defining MSISDN field presence in a subrecord (if a bit value is 1, then a field is transmitted, if 0, it is not transmitted);
- HDID is an identifier of a "home" telematic platform (a detailed VS registration data is stored on this platform);
- IMEI is a mobile device (modem) identifier. If this parameter cannot be defined, VS should put 0 in 15 symbols of this field;
- IMSI is a mobile subscriber identifier. If this parameter cannot be defined, VS should put 0 in 16 symbols of this field;
- LNGC is a language code, preferable on VS side in compliance with standard [4], for example, "rus" - Russian;
- NID is an identifier of the operator net, VS is registered in. 20 low bits are used. It presents several MCC-MNC codes. NID field structure is given in Table 20;
- BS is a maximum size of VS receive buffer in bytes. A size of each data packet transmitted to VS should not exceed this value. BS field value can vary (1024, 2048,4096), it depends on a software and hardware implementation of a certain VS;
- MSISDN is a mobile subscriber phone number. If this parameter cannot be defined, a device should put 0 in 15 symbols of this field (a format description is given in a reference document [4]).

HDID field transmission is defined by VS settings and is regarded as reasonable, if VS can be connected to a different telematic platform (not a "home" one), for example, when a geographically-distributed platform network is used. If only a "home" platform is used, HDID transmission is not necessary.

A "simple" service use algorithm provides that VS has access to all services; in this mode VS is allowed to send data for a required service immediately. Depending on permissions, valid on the telematic platform for the specified VS, a confirmation record with the corresponding error flag can be sent back after a data packet is received. For systems with a simple service usage right distribution a simple algorithm is recommended. It reduces a volume of the sent traffic and VS authorization time.

"Request" algorithm on services usage implies that VS should receive data about accessible services from the telematic platform before use of this or that type of service (data sending). Request for service usage can be performed either on authorization stage, or later. At an authorization stage a request for this or that service usage is performed through adding SRSERVICEINFO subrecords and setting bit 7 of SRVP field to 1. After authorization the service usage request can be executed by means of SR_ SERVICEINFO subrecords.

Table 20 - EGTS_AUTH_SERVICE service EGTS_SR_TERM_IDENTITY subrecord NID field format

Bits 20.. .23	Bits 10...19	Bits 0...9	Type	Data type	Size, bytes
-	MCC (Mobile Country Code)	MNC (Mobile Network Code)	M	BINARY	3

MCC and MNC combination defines a unique identifier of GSM, CDMA, TETRA, UMTS mobile operator and of several satellite communication operators.

NID field parameters of EGTS_SR_TERM_IDENTITY subrecord have the following assignment:

- MCC is a country code;
- MNC is a mobile network code within the country.

4.7.2.3 EGTS_SR_MODULE_DATA subrecord. A subrecord structure is given in Table 21.

Table 21 - A format of EGTS_SR_MODULE_DATA subrecord of EGTS_AUTH_SERVICE service

Bit 7	Bit 6	Bit 5	Bit 4	Bit 3	Bit 2	Bit 1	Bit 0	Type	Data type	Size, bytes
MT (Module Type)								M	BYTE	1
VID (Vendor Identifier)								M	UINT	4
FWV (Firmware Version)								M	USHORT	2
SWV (Software Version)								M	USHORT	2
MD (Modification)								M	BYTE	1
ST (State)								M	BYTE	1
SRN (Serial Number)								O	STRING	0 ... 32
D (Delimiter)								M	BYTE	1
DSCR (Description)								O	STRING	0 ... 32
D (Delimiter)								M	BYTE	1

SR_MODULE_DATA subrecord fields have the following meaning: - MT is a type of module according to its function (1 is a main module; 2 is an input/output module; 3 is a navigation receiver module; 4 is a wireless module). Here the recommended rules of module types numeration are specified. A specific authorization service implementation can put in and expand its own numeration of types, including all external peripheral controllers;

- VID is a manufacturer's code;
- FWV is a module hardware version (a high byte - a number before a point - major version, a low byte - after the point - minor version, e.g. 2.34 version will be presented with a number 0x0222);
- SWV is a module software version (a high byte - a number before the point, a low byte - after the point);
- MD is a module software modification code;
- ST is a status (1 - on, 0- off, above 127 - failure, (see Appendix C));
- SRN is a module serial number;
- D is a separation character of line parameters (its value is always 0);
- DSCR is a brief module description.

4.7.2.4 Table 22 - A format of EGTS_SR_VEHICLE_DATA subrecord of EGTS_AUTH_SERVICE service

Bit 7	Bit 6	Bit 5	Bit 4	Bit 3	Bit 2	Bit 1	Bit 0	Type	Data type	Size, bytes
VIN (Vehicle Identification Number)								M	STRING	17
VHT (Vehicle Type)								M	UINT	4
VPST (Vehicle Propulsion Storage Type)								M	UINT	4

EGTS_SR_VEHICLE_DATA subrecord fields have the following meaning:

- VIN is a vehicle identification code;
- VHT is a vehicle type;
 - a) Bit 31 - 5: not used;
 - b) Bit 4-0;
 - c) 0001 - passenger (Class M1);
 - d) 0010 - bus (Class M2);
 - e) 0011 - bus (Class M3);
 - f) 0100 - a light truck (Class N1);
 - g) 0101 - a heavy truck (Class N2);
 - h) 0110 - a heavy truck (Class N3);
 - i) 0111 - a bike (Class L1e);
 - j) 1000 - a bike (Class L2e);
 - k) 1001 - a bike (Class L3e);
 - l) 1010 - a bike (Class L4e);
 - m) 1011 - a bike (Class L5e);
 - n) 1100 - a bike (Class L6e);
 - o) 1101 - a bike (Class L7e).
- VPST is a vehicle energy material. If all bits are 0, the type is not set:
 - a) Bit 31 - 6: not used;
 - b) Bit 5: 1 - nitrogen;
 - c) Bit 4: 1 - electricity (over 42V and 100 A/h);
 - d) Bit 3: 1 - liquid propane (LPG);
 - e) Bit 2: 1 - compressed natural gas (CNG);
 - f) Bit 1: 1 - diesel;
 - g) Bit 0: 1 - gasoline.

4.7.2.5 EGTS_SR_AUTH_PARAMS subrecord.

A subrecord structure is given in Table 23.

Table 23 - A format of EGTS_SR_AUTH_PARAMS subrecord of EGTS_AUTH_SERVICE service

Bit 7	Bit 6	Bit 5	Bit 4	Bit 3	Bit 2	Bit 1	Bit 0	Type	Data type	Size, bytes
FLG (Flags)								M	BYTE	1
-	EXE	SSE	MSE	ISLE	PKE	ENA				
PKL (Public Key Length)								O	USHORT	2
PKL (Public Key Length)								O	BINARY	0...512
ISL (Identity String Length)								O	USHORT	2
MSZ (Mod Size)								O	USHORT	2
SS (Server Sequence)								O	STRING	0...255
D (Delimiter)								O	BYTE	1
EXP (Exp)								O	STRING	0...255
D (Delimiter)								O	BYTE	1

EGTS_SR_AUTH_PARAMS subrecord fields have the following meaning:

- EXE is a bit flag, defining a presence of EXP field and a D-separator, next to it (if a value is 1, fields are present);
- SSE is a bit flag, defining a presence of SS field and a D-separator, next to it (if a value is 1, fields are present);
- MSE is a bit flag, defining MSZ field presence (if its value is 1, the field is present);
- ISLE is a bit flag, defining ISL field presence (if its value is 1, the field is present);
- PKE is a bit flag, defining PKL and PBK field presence (if its value is 1, the fields are present);
- ENA is a bit field, defining a required packet coding algorithm. If a value in this field is 0, then coding is not applied, and EGTS_SR_AUTH_PARAMS subrecord comprises one byte only, otherwise, optional parameters application is determined by FLG field bits, depending on the algorithm type;
- PKL is a public key length in bytes;
- PBK are public key data;
- ISL is a resulting length of identification data;
- MSZ is a coding parameter;
- SS is a special server byte ordering, applied for coding;
- D is a separation character of line parameters (its value is always 0);
- EXP is a special sequence, used for coding.

If coding is required and a requested coding algorithm is supported, an authorized side should form and send EGTS_SR_AUTH_INFO record, coded according to the specified algorithm. Upon that bits 11 and 12 in a transport level header field KEYS are set to corresponding values, and further on, the coded data are transmitted.

If the required coding algorithm is not supported, the initiating party sends EGTS_SR_RECORD_RESPONSE subrecord with the corresponding error flag.

The record can also comprise EGTS_SR_SERVICE_INFO subrecords, defining a number and parameters of services, supported and required by the initiating party, depending on the used service request algorithm.

4.7.2.6 EGTS_SR_AUTH_INFO subrecord

A subrecord structure is given in Table 24.

Table 24 - EGTS_SR_AUTHINFO subrecord structure of EGTS_AUTH_SERVICE service

Bit 7	Bit 6	Bit 5	Bit 4	Bit 3	Bit 2	Bit 1	Bit 0	Type	Data type x	Size, bytes
UNM (User Name)								M	STRING	0...32
D (Delimiter)								M	BYTE	1
UPSW (User Password)								M	STRING	0...32
D (Delimiter)								M	BYTE	1
SS (Server Sequence)								O	STRING	0...255
D (Delimiter)								O	BYTE	1

EGTS_SR_AUTH_INFO subrecord fields have the following meaning:

- UNM is a user name;
- D is a separation character of line parameters (its value is always 0);
- UPSW is a user password;
- SS is a special server byte sequence, transmitted in EGTS_SR_AUTH_PARAMS subrecord (this field is optional, its use depends on the used coding algorithm).

4.7.2.7 EGTS_SR_SERVICE_INFO subrecord.

A subrecord structure is given in Table 25.

Table 25 - EGTS_SR_SERVICE_INFO subrecord structure of EGTS_AUTH_SERVICE service

Bit 7	Bit 6	Bit 5	Bit 4	Bit 3	Bit 2	Bit 1	Bit 0	Type	Data type x	Size, bytes
ST (Service Type)								M	BYTE	1
SST (Service Statement)								M	BYTE	1
SRVP (Service Parameters)								M	BYTE	1
SRVA	-					SRVRP				

EGTS_SR_SERVICE_INFO subrecord fields have the following meaning:

- ST is a type of service according to its function (for example, EGTSTELEDATASERVICE, EGTS_ECALL_SERVICE, etc.);
- SST defines a current service state (see Table 26);
- SRVP defines service parameters;
- SRVA is a bit flag, Service Attribute:

a) 0 - supported service;

b) 1 - requested service.

- SRVRP - (Service Routing Priority) is a bit field, first to receive data translation (in case of system scaling and application of several copies of one service type), defined by bits 0 and 1:

a) 00 - the highest;

b) 01 - high;

c) 10 - medium;

d) 11 - low.

Table 26 - A list of possible service states

Code	Name	Description
0	EGTS_SST_IN_SERVICE	Service is in working condition and allowed to use
128	EGT S_SST_OUT_OF_SERVICE	Service is out-of-service (switched off)
129	EGTS_SST_DENIED	Service usage is forbidden
130	EGTS_SST_NO_CONF	Service is not configured
131	EGT S_SST_TEMPUNAVAIL	Service is temporarily unavailable

4.7.2.8 EGTS_SR_RESULT_CODE subrecord.

A subrecord structure is given in Table 27.

Table 27 - EGTS_AUTH_SERVICE service EGTS_SR_RESULTCODE subrecord structure

Bit 7	Bit 6	Bit 5	Bit 4	Bit 3	Bit 2	Bit 1	Bit 0	Type	Data type	Size, bytes
RCD (ResultCode)								M	BYTE	1

EGTS_SR_SERVICE_INFO subrecord fields have the following meaning:

- RCD is a code defining an authorization performance result.

4.7.2.9 Authorization procedure description

For operation in VS ERA operator's infrastructure a unique identifier UNITID is required, which corresponds to certain IMEI, IMSI values and other VS registration data, needed to interact in the operator's system.

VS can be configured using one of the following methods.

1) In VS passive operation mode after "Additional functions" button activation and VS registration in GSM or UMTS network, a cellular provider infrastructure traces a new

device and sends a coded SMS with registration data to it. Coding is performed using a key and an algorithm, known to this VS pattern and stored before configuration in operator's storage base. In order to define the encoding keys and algorithms on VS side the corresponding fields of the transport protocol header are use, as well as key data in VS memory. Registration data are transferred as a configuration file with a subrecord

EGTS_SR_SERVICE_FULL_DATA or EGTS_SR_SERVICE_PART_DATA of EGTS_FIRMWARE_SERVICE service.

A configuration file should comprise: the parameter EGTS_GPRS_APN (access point parameters for GPRS session establishment), the parameter EGTS_SERVER_ADDRESS, defining a server address and port for TCP/IP connection establishment, and a unique identifier AC UNIT_ID. A configuration file can comprise other parameters, required for VS operation.

Further on, VS deciphers SMS message, checks up data structures correctness, calculates and compares check sums with values, received in the message. If deciphering and check-up were successful, VS sets up a GPRS session and connects to the specified server via TCP/IP.

After authentication a successful configuration confirmation message is sent in response to a received EGT S_SR_SERVICE_FULL_DAT A or EGTS_SR_SERVICE_PART_DATA record of EGTS_FIRMWARE_SERVICE service; the configuration message comprises EGTS_PC_OK code.

Algorithm of such VS configuring method is given on Figure 4.

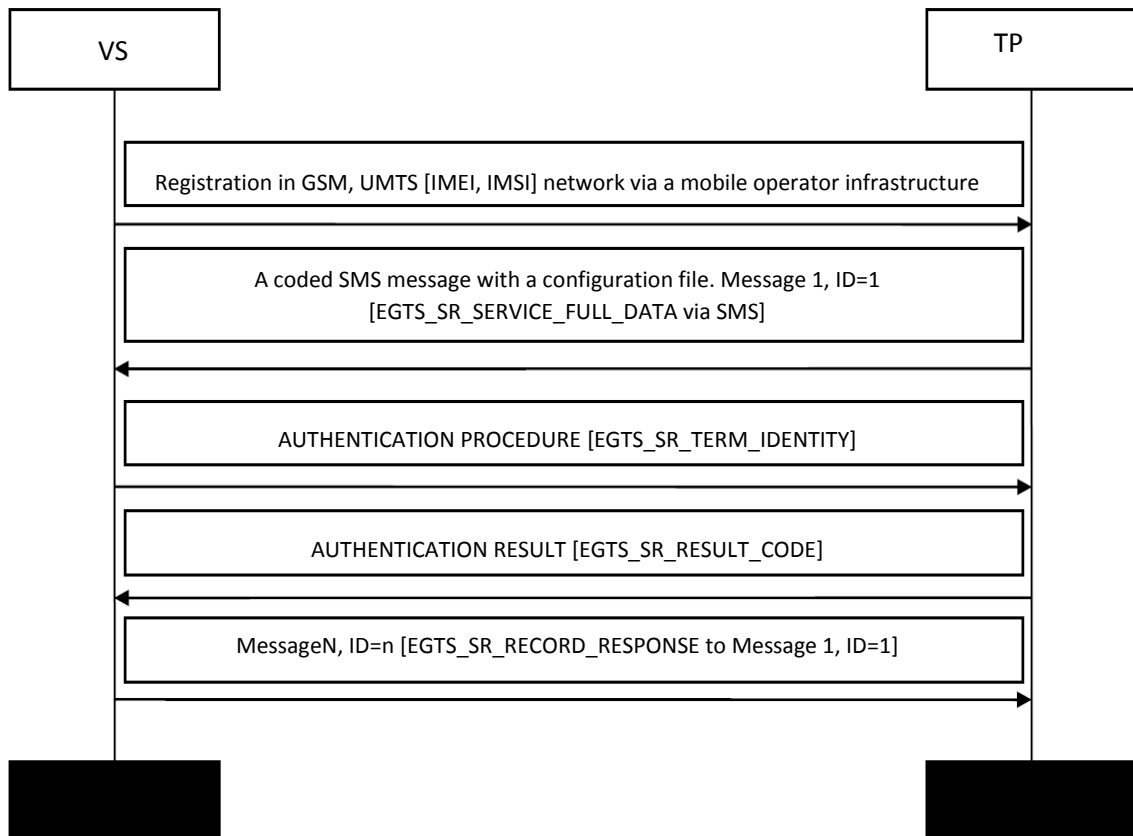

Figure 4 - Algorithm of VS configuration using SM

2) After VS registration in GSM or UMTS network a GPRS session and TCP/IP connection to server are established; address data are already stored in VS memory. During authentication an operator's infrastructure analyses TID parameter from EGTS_SR_TERM_IDENTITY subrecord (Table 18). If TID value is 0, configuration is performed using EGTS_FIRMWARE_SERVICE service, according to the previous method description: the configuration file is sent with a subrecord

EGTS_SR_SERVICE_FULL_DATA or EGTS_SR_SERVICE_PART_DATA. When VS confirms configuration file reception, an authorization result with a EGTS_PC_ID_NFOUND code is sent to VS, denoting that TID=0 is not found in the system. After that, the server

is waiting for repeated VS authorization with the correct TID parameter, whereas the connection with VS is preserved. Algorithm of such VS configuring method is given on Figure 5.

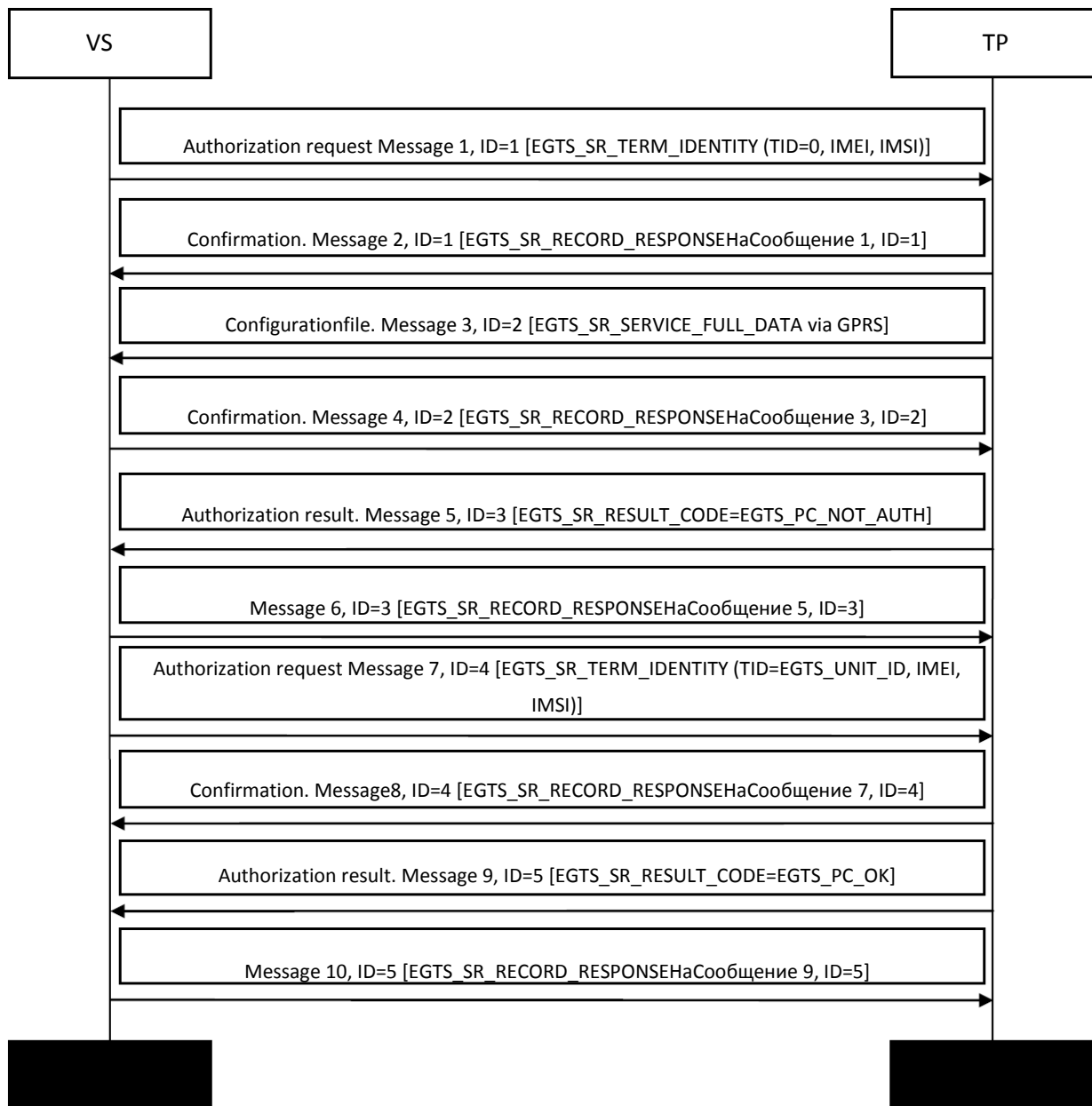

Figure 5 - VS configuration algorithm using GPRS

If authorization is performed successfully, a telematic platform can add EGTS_SR_SERVICE_INFO type subrecords before the EGTS_SR_RESULT_CODE subrecord, to define service structures, allowed for VS and supported by the platform depending on the service usage request algorithm.

It means that just after authorization VS can use the enlisted services only, even though a "simple" service usage right support algorithm is supposed to be used.

If a service usage "request" algorithm is used, then VS can use the services, permitted by the telematic platform only. Besides, permit to use some of the requested services can be received later. For example, when services are on remote telematic platforms, which answer the requests in the asynchronous mode. In this case a telematic platform, using current routing data, sends an asynchronous request for the remote platform services usage, if HDID identifier is denoted in EGTS_SR_TERM_IDENTITY subrecord in the process of VS authorization.

Message exchange algorithm at VS authorization stage on the telematic platform side is shown as a chart on Figure 6.

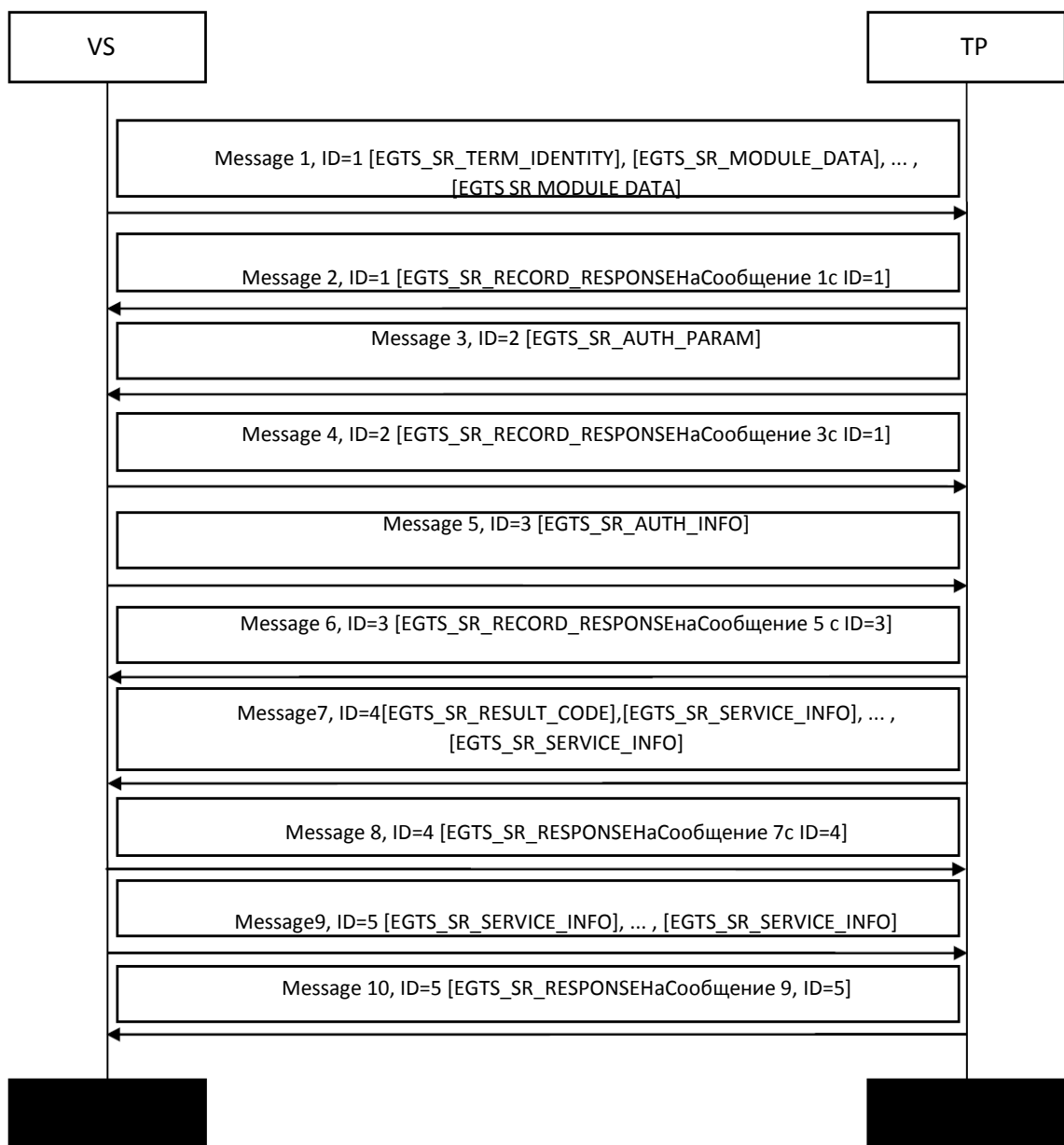

Figure 6 - Message exchange at VS authorization stage on the telematic platform

After successful VS connection to the telematic platform via TCP/IP protocol VS should be authorized. In order to transmit authentication data VS should send a message with EGTS_SR_TERM_IDENTITY subrecord (message 1) within a time period EGTS_SL_NOT_AUTH_TO.

Telematic platform received a message with EGTS_SR_TERM_IDENTITY subrecord and answers back with message 2 to confirm reception and record of EGTS_SR_RECORD_RESPONSE and ID identifier, set to 1. Further on, according to the settings (coding or an additional authorization algorithm is used) the telematic platform sends a packet (message 3) with a EGTS_SR_AUTH_PARAM subrecord parameters, required for coding and/or an expanded authorization algorithm. If coding and an expanded authorization algorithm is not used, then instead of EGTS_SR_AUTH_PARAM subrecord a telematic platform can send the EGTS_SR_RESULT_CODE subrecord with a VS authorization procedure results.

Further on, VS sends message for 4 s and a EGTS_SR_RECORD_RESPONSE confirmation of message 3 and ID, which is set to 2. Using an expanded authorization and/or coding algorithm, VS sends message 5, encoded according to the coding rules, specified in message 3 from the telematic platform and comprising EGTS_SR_AUTH_INFO subrecord with expanded authorization data.

After EGTS_SR_AUTH_INFO receiving the telematic platform sends message 6, which contains the confirmation to message 5 and ID, equal to 3, and performs an authorization. The platform builds up message 7 with an authorization result in the form of EGTS_SR_RESULT_CODE subrecord, and in case of successful authorization it can add data on service usage permits for this VS, sent as EGTS_SR_SERVICE_INFO subrecords.

Then VS builds up message 8 with the confirmation to message 7 and ID, set to 4. VS can form message 9 and add EGTS_SR_SERVICE_INFO subrecords, that contain data on required services (if a service usage procedure "on request") and/or supported services on VS side.

Further on the telematic platform builds up message 10 with the confirmation to message 9 and ID, set to 5.

At this point an authorization stage is over, and VS turns to the stage of data message exchange with the platform according to the operational mode, set in VS.

In case the authorization procedure passes unsuccessfully (invalid authentication VS data, VS access to the telematic platform is denied, etc.), then after sending a message with EGTS_SR_RESULT_CODE subrecord and a corresponding code, the telematic platform should interrupt TCP/IP connection established by the vehicle system.

4.7.3 EGTS_COMMANDS_SERVICE service

This type of service is intended for processing the commands, messages and confirmations, transmitted between VS, the telematic platform and client applications.

In order to perform interaction in terms of this service a EGTS_SR_COMMAND_DATA subrecord is used, its description and code are given in Table 28.

Table 28 - EGTS_COMMAND_SERVICE service subrecords description

Code	Name	Description
0	EGTS_SR_RECORD_RESPONSE	A subrecord is applied only to confirm a service support protocol record processing. This type of subrecord should be supported by all services.
51	EGTS_SR_COMMAND_DATA	VS and the telematic platform use this subrecord for commands, data messages transmission, and confirmation of delivery, commands fulfilment and message reading.

4.7.3.1 EGT S_SR_COMMAND_DATA subrecord.

A subrecord structure is given in Table 29.

Table 29 - EGTS_SR_COMMAND_DATA service subrecord structure EGTS_COMMANDS_SERVICE

Bit 7	Bit 6	Bit 5	Bit 4	Bit 3	Bit 2	Bit 1	Bit 0	Type	Data type	Size, bytes
CT (Command Type)				CCT (Command Confirmation Type)				M	BYTE	1
CID (Command Identifier)								M	UINT	4
SID (Source Identifier)								M	UINT	4
-						ACFE	CHSFE	M	BYTE	1
CHS (Charset)								O	BYTE	1
ACL (Authorization Code Length)								O	BYTE	1
AC (Authorization Code)								O	BINARY	0 ... 255
CD (Command Data)								O	BINARY	0..65205

Parameters of EGTS_SR_COMMAND_DATA subrecord (field), provided in Table 29, have the following assignment:

- CT is a command type:

- a) 0001 - CTCOMCONF is a confirmation of command reception, processing or fulfilment result;
- b) 0010 - CTMSGCONF is a confirmation of data message reception, displaying and/or processing;
- c) 0011 - CTMSGFROM is a data message from VS;
- d) 0100 - CT_MSGTO – a data message for output to a vehicle display;
- e) 0101 - CT_COM – a command to be executed by a vehicle
- f) 0110 - CT_DELCOM is a removal of previously transmitted command from the queue;
- g) 0111 - CT_SUBREQ is an additional subrequest for

fulfilment (to the previously sent command);

h) 1000 - CT_DELIV is a confirmation of command or data message delivery.

- CCT is a type of confirmation (valid for commands of CTCOMCONF, CTMSGCONF, CTDELIV types):

a) 0000 - CC_OK is a successful performance, a positive answer;

b) 0001 - CC_ERROR - processing failure;

c) 0010 - CC_ILL a command cannot be

executed, since there aren't permitted (according to the protocol) commands in the list or permit to execute this command;

d) 0011 - CC_DEL - a command has been successfully removed;

e) 0100 - CCNFOUND - a removal command is not found;

f) 0000 - CC_OK - a successful performance, a negative answer;

g) 0110 - CC_INPROG - a command is sent for processing, but it takes much time to execute it (fulfilment result is not known yet).

SID is the command or confirmation sender's identifier; When sending a command confirmation or a command execution result (CT_COMCONF, CT_MSGCONF, CT_DELIV command types) to a TP, the SID value should be copied from the SID field of the command previously received by the VS. When EGTS_SR_COMMAND_DATA subrecord transmission is initiated on the terminal side, this field has a value of 0;

- ACFE - (Authorization Code Field Exists) a bit flag, defining ACL and AC fields presence in a subrecord:

a) 1 - ACL and AC fields are present in a subrecord;

b) 0 - no ACL and AC fields in a subrecord.

- CHSFE - (Charset Field Exists) a bit flag, defining CHS field presence in a subrecord:

a) 1 - CHS field is present in a subrecord;

b) 0 - no CHS field is in a subrecord;

-CHS is a symbol coding, used in CD field, which contains a command body. If there is no such field, CP-1251 coding should be used by default. The following values of CHS field (in a decimal form) are defined:

a) 0 - CP-1251;

b) 1 - IA5 (CCITT T.50)/ASCII (ANSI X3.4);

c) 2 - binary data;

d) 3 - Latin 1 (Table F.1 (Appendix F));

e) 4 - binary data;

f) 5 - JIS (X 0208-1990);

g) 6 - Cyrillic (Table F.1 (Appendix F));

h) 7 - Latin/Hebrew (Table F.3 (Appendix F));

i) 8 - UCS2.

- ACL is AC field length in byte, where an authorization code on receiver's side is comprised;

- AC is an authorization code, used on receiving side (a vehicle system), which restricts access to some commands execution. If a code, specified in this field, does not coincide with the design value, then a vehicle system should answer back the confirmation with the type

CC_ILL;

- CD is a command body, parameters, data, returned on the request command, using a coding in CHS field or a default value.

A size of this field is defined, proceeding from a total length of the service support protocol record and a length of the previous fields in this subrecord. A command format is given in Table 30. This field can have a zero length in case, no data are received in answer to the command or a message for VS.

Table 30 - A vehicle system command format

Bit 7	Bit 6	Bit 5	Bit 4	Bit 3	Bit 2	Bit 1	Bit 0	Type	Data type	Size, bytes
ADR (Address)								M	USHORT	2
SZ (Size)				ACT (Action)				M	BYTE	1
CCD (Command Code)								M	USHORT	2
DT (Data)								O	BINARY	0 ... 65200

Parameters, given in Table 30, have the following assignment:

-ADR is an address of the module, the command is intended for. The address is defined according to the initial VS configuration or from the module list, that can be received at VS registration via EGT S_AUTH_SERVICE service and EGT S_SR_MODULE_DATA subrecords transmission.

- SZ is a memory size for the parameter (used along with ACT-2 operation). When a new parameter is added to VS, this field defines, that a new parameter requires 2 byte in VS memory;

- ACT is an operation description, used in case of the command type, field CT-CTCOM of EGTS_SR_COMMAND DATA subrecord. Field value can be one of the following variants:

a) 0 - command parameters. Used for parameters transmission for a command, defined by the code in CCD field;

b) 1 - value request. Used to request for data, stored in VS. The requested parameter is determined by the code in CCD field;

c) 2 - value setting. Used to set a specified VS parameter to a new value. The parameter to be set up is defined by the code in CCD field, and its value is determined by DT field;

d) 3 - adding a new VS parameter. A new parameter code is specified in CCD field, its type is comprised in SZ field, and its value can be found in DT field;

e) 4 - removal of the current VS parameter. A removed parameter code is specified in CCD field.

- CCD is a command code at ACT-0 or a parameter code at ACT-1..4;

- DT - requested data or parameters, required for command execution. Data are recorded in this field in a format corresponding to the command type.

If the associated data are sent with VS, a confirmation to the previously transmitted command at CT-CT_COMCONF has a format, specified in Table 31. The described structure is in CD field (Table 29).

Table 31 - A format of confirmation to VS command

Bit 7	Bit 6	Bit 5	Bit 4	Bit 3	Bit 2	Bit 1	Bit 0	Type	Data type	Size, bytes
ADR (Address)								M	USHORT	2
CCD (Command Code)								M	USHORT	2
DT (Data)								O	BINARY	0..65200

Parameters, given in Table 31, have the following assignment:

- ADR is an address of the module that sends a confirmation. The address is defined according to the initial VS configuration or from the module list that can be received at VS registration via EGT S_AUTH_SERVICE service and EGT S_SR_MODULE_DATA subrecords transmission;
- CCD is a code of a command, a message from Table 32 or a parameter from Table 34, which determines associated data, transmitted in DT field;
- DT are the associated data, their type and content are defined by CCD field value. A list and content of associated data, transmitted in a confirmation to some of commands, are provided in Table 33.

4.7.3.2 Commands, parameters and confirmations characteristic

A list and description of VS commands are given in Table 32.

Values of the following VS parameters can be requested, but cannot be changed or removed, using a command service:

EGTS_UNIT_SERIAL_NUMBER, EGTS_UNIT_HW_VERSION,
EGTS_UNIT_SW_VERSION, EGTSUNITVENDORID,
EGTS_UNIT_IMEI.

Values of the specified parameters are set by manufacturers of the corresponding VS modules and units, and by designers of the software to this equipment.

The vehicle systems, installed as standard equipment, should support the following parameters:

- EGTS_GPRS_APN;
- EGTS_SERVER_ADDRESS;
- EGTS_SIM_PIN;
- EGTS_AUTOMATIC_REGISTRATION;
- EGTS_SELFTEST_INTERVAL;
- EGTS_POST_TEST_REGISTRATION_TIME;
- EGTS_TEST_MODE_END_DISTANCE;
- EGTS_GARAGE_MODE_END_DISTANCE;
- EGTS_TEST_MODE_WATCHDOG;
- EGTS_USE_GPRS_WHITE_LIST;
- EGTS_GPRS_WHITE_LIST;
- EGTS_TEST_REGISTRATION_PERIOD;

- EGTS_GNSS_POWER_OFF_TIME;
- EGTS_GNSS_DATA_RATE;
- EGTS_GNSS_MIN_ELEVATION;
- EGTS_UNIT_SERIAL_NUMBER;
- EGTS_UNIT_HW_VERSION;
- EGTS_UNIT_SW_VERSION;
- EGTS_UNIT_VENDOR_ID;
- EGTS_UNIT_ID;
- EGTS_UNIT_LANGUAGE_ID;
- EGTS_UNIT_IMEI;
- EGTS_UNIT_HOME_DISPATCHER_ID.

Table 32 - A VS command list

Command name	Code	Type, number and threshold parameter values	Description
EGTS_RAW_DATA	0x0000	BINARY (up to 65200 byte)	A random data transmission command. It is applied for transmission of commands, messages and data to, for example, peripheral devices, modules, connected to the main VS unit, in a format, defined by this module. Upon that VS should not analyse DT field data and transmit it as they are at the address, specified in ADR field.
EGTS_TEST_MODE	0x0001	BYTE	VS testing start/end command. 1 - test start, 0 -test end.
EGTS_CONFIG_RESET	0x0006		Return to default settings. All parameters, set by the user, are deleted, and default settings are restored. An operator should set up correct ACL and AC field values, specified in Table 29, in order to process this command.
EGTS_SET_AUTH_C ODE	0x0007	BINARY	Authorization code setup on VS side. An operator should set up correct ACL and AC field values, specified in Table 29, in order to process this command. After the command is confirmed, VS shall compare new data with an AC field value in some of the commands, transmitted to VS.
EGTSRESTART	0x0008		The command restarts main VS software. An operator should set up correct ACL and AC field values, specified in Table 29, in order to process this command.

Table 33 - A list of VS confirmations to commands and messages

Command name	Code	Parameters type and number	Description
EGTS_RAW_DATA	0x0000	BINARY (up to 65200 byte)	Data, supplied by peripheral devices, modules, connected to the main VS unit, in a format, defined by this module.
EGTS_SELF_TEST_RESULT	0x0002	STRING	Self-testing result message. VS generated it automatically without an operator's request.

Table 34 - A VS parameters list

Parameter	Code	Parameter type	Default value	Description
Radio mute (only in a supplementary equipment configuration)				
EGTS_RADIO_MUTE_DELAY	0x0201	INT	0	A delay between a radio mute signal setup and a sound play start, (ms).
EGTS_RADIO_UNMUTEDELAY	0x0202	INT	0	A delay between a radio mute signal annulment and a sound play ending, (ms).
General purpose settings				
EGTS_GPRS_APN	0x0203	STRING	""	A parameter, defining GPRS access point.
EGTS_SERVER_ADDRESS	0x0204	STRING	""	A server connection address and port via TCP/IP protocol.
EGTSSIMPIN	0x0205	INT	0	PIN code of a SIM card
EGTS_AUTOMATIC_REGISTRATION	0x0207	BOOLEAN	1	This flag allows an automatic registration of SIM in the network when power is on.
EGTS_SELFTEST_INTERVAL	0x0208	INT	0	Regular self-test performance interval, hours. If the setting is set to 0, self-test is not performed.
EGTS_POST_TEST_REGISTRATIONTIME	0x0209	INT	120	VS stays registered in the network during this period after self-test results transmission to the system operator, (s).
EGTS_TEST_MODE_ENDDISTANCE	0x020A	INT	300	A distance, required for the test mode to turn off automatically, (metres).
EGTS_GARAGE_MODE_ENDDISTANCE	0x020B	INT	300	A distance, required for the "autoservice" mode to turn off automatically, (metres).
EGTS_GARAGE_MODE_PIN	0x020C	ENUM {NONE-0, PIN_1-1, .. PIN_8-8}	0	A line, sending a signal that the system is in "autoservice" mode: NONE - no mode alarm system, PIN X - PIN X - the line is active, when a system is in this mode.
EGTS_TEST_MODE_WATCHDOG	0x020E	INT	10	Alarm counter interval in a test mode, (min).
Configuration and service configuration data				
Data packet transmission				
EGTS_USE_GPRS_WHITELIST	0x0230	BOOLEAN	FALSE	A parameter denoting the need to use GPRS WHITE LIST for data packet transmission.
EGTS_GPRS_WHITE_LIST	0x0231	ARRAY OF STRING	"" "" "" "" , , , , "" "" "" "" , , , , "" "" "" "" , , , ,	A list of networks, where the data packet transmission is allowed. If GPRS_WHITE_LIST list is empty, then data

			<pre> ''' ''' '' '' , , , , '' '' '' '' '' , , , , </pre>	packet transmission is forbidden, MCC (Mobile Country Code) 3 symbols +MNC(Mobile Network Code), (3 symbols).
Test mode				
EGTS_TEST_REGISTRATION_PERIOD	0x0242	INT	5	If VS was registered in the network earlier by pushing the "optional services on" button, then the next VS registration in the network using this button is possible only after this time period. If the value is set to 0, then there are no restrictions on the following VS registration in network, (min).
Other parameters				
EGTS_GNSS_POWER_OFF_TIME	0x0301	INT	500	A time period till the GNS receiver power-off after the ignition is shut off, (ms).
EGTS_GNSS_DATA_RATE	0x0302	INT/ 1, 2,5,10	Defined by VS manufacturer	Speed of data output by GNSS receiver, (Hz).
EGTS_GNSS_MIN_ELEVATION	0x0303	INT/ 5...15	15	Navigation space vehicles minimum elevation (cutoff) angle value, (degrees).
Device parameters				
EGTS_UNIT_SERIAL_NUMBER	0x0400	STRING	""	A device serial number.
EGTS_UNIT_HW_VERSION	0x0401	STRING	""	A hardware platform version.
EGTS_UNIT_SW_VERSION	0x0402	STRING	""	A software version.
EGTSUNITVENDOR_ID	0x0403	INT	0	Device supplier identifier.
EGTSUNITID	0x0404	INT	0	A unique device identifier, assigned by a system operator at the first device activation.
EGTS_UNIT_IMEI	0x0405	STRING	""	IMEI number
EGTS_UNIT_RS485_BAUDRATE	0x0406	INT	19200	RS485 port speed
EGTS_UNIT_RS485_STOPBITS	0x0407	INT	1	Stop bits number during data transmission via RS485 port.
EGTS_UNIT_RS485_PARITY	0x0408	INT/0,1,2	0	Parity check method while data transmitting via RS485 port 0 - no check 1 - ODD type check 2 - EVEN type check.
EGTS_UNIT_LANGUAGEID	0x0410	INT	0	A preferable language for voice communication according to the reference document [4] 0x5F - Russian.
EGTS_UNIT_HOME_D I SPATCHERID	0x0411	INT	0	An identifier of the telematic platform, which contains device registration data, a list of delivered services and their status.
EGTS_SERVICE_AUTH_METHOD	0x0412	INT	1	Service use method. 1 - a simple method (implies that VS has access to all services by default), 0 - with a confirmation (it is allowed to use services only if there is a permit, sent from the telematic platform).

EGTS_SERVER_CHEC KINPERIOD	0x0413	INT	30	A time period between trials to establish TCP/IP connection with a server, (seconds).
EGTS_SERVER_CHEC K_IN_ATTEMPTS	0x0414	INT	5	A number of TCP/IP connection setup attempts with a server, before a high level session setup (GPRS) is repeated
EGTS_SERVER_ PACKETTOUT	0x0415	INT	5	Time, VS is waiting for a server confirmation to the sent packet, (seconds).
EGTS_SERVER_PACK ET_RETRANSMIT_ ATTEMPTS	0x0416	INT	3	A number of attempts to send an unconfirmed packet before VS performs another session initialization on TCP/IP level.
EGTS_UNIT_MIC_ LEVEL	0x0417	INT/ 0..0.10	8	Microphone sensitivity level.
EGTS_UNIT_SPK_ LEVEL	0x0418	INT/ 0..0.10	6	Speaker loudness level.

4.7.4 EGTS_FIRMWARE_SERVICE service

EGTS_FIRMWARE_SERVICE service is intended for configuration transmission to VS and a software update on VS modules and units, and on peripheral equipment, connected to VS.

In order to perform interaction in terms of this service several subrecords are used, their description and code are given in Table 35.

Table 35 - A list of subrecords of EGTS_FIRMWARE_SERVICE service

Code	Name	Description
0	EGTS_SR_RECORD_ RESPONSE	A subrecord is applied for confirmation of the service support protocol record from the EGTS_PT_APPDATA. packet
33	EGTS_SR_SERVICE_ PART_DATA	A subrecord is intended for sequential transmission of parted data to VS. This subrecord is used for transmission of large objects, since they are too long to be transmitted to VS in one packet.
34	EGTS_SR_SERVICE_ FULLDATA	A subrecord is intended for transmission of single data, which transmitted to VS in one packet.

4.7.4.1 EGT S_SR_SERVICE_PART_DATA subrecord

EGTS_SR_SERVICE_PART_DATA subrecord can be used by service to transmit essences to VS. A subrecord structure is given in Table 36.

Table 36 - EGTS_SR_SERVICE_PART_DATA service subrecord structure
EGTS_FIRMWARE_SERVICE

Bit 7	Bit 6	Bit 5	Bit 4	Bit 3	Bit 2	Bit 1	Bit 0	Type	Data type	Size, bytes
ID (Identity)								M	USHORT	2
PN (Part Number)								M	USHORT	2
EPQ (Expected Parts Quantity)								M	USHORT	2
ODH (Object Data Header)								O	BINARY	0..71
OD (Object Data)								M	BINARY	1..65400

Notes:

1. ID is a unique identifier of the transmitted essence. It is incremented when a new essence transmission starts. This parameter allows identifying precisely the essence, this part belongs to.
2. PN is a sequential number of the transmitted essence current part.
3. EPQ is an expected number of transmitted essence parts
4. ODH is a header with parameters, characterizing a transmitted essence. This header is transmitted only for the first part of essence. During transmission of the second and the rest of parts, this field is not transmitted. ODH header structure is given in Table 36.
5. OD is the transmitted essence data.

EPQ parameter comprises a number of parts to be transmitted, and PN parameter shows the current part number. ID field precisely defines the essence, the transmitted part belongs to. EPQ and PN parameters for this subrecord should contain value range of 1 to 65535, except that a PN field value should be less than EPQ field value or be equal to it. If this condition is broken, then data of such subrecord are ignored.

An identifier of ID object, PN and EPQ fields, as well as OID record source identifier from the service routing header allows to define, which part of what object is received to be processed. It allows to transmit essences for software update in different VS equipment units and in peripheral equipment at the same time and at a sufficient channel capacity.

Table 37 - A transmitted essence header format of EGTSFIRMWARESERVICE service
EGTS_SR_SERVICE_PART_DATA subrecord

Bit 7	Bit 6	Bit 5	Bit 4	Bit 3	Bit 2	Bit 1	Bit 0	Type	Data type	Size, bytes
OA (Object Attribute)								M	BYTE	1
-			OT (Object Type)		MT (Module Type)					
CMI (Component or Module Identifier)								M	BYTE	1
VER (Version)								M	USHORT	2
WOS (Whole Object Signature)								M	USHORT	2
FN (File Name)								O	STRING	0..64
D (Delimiter)								M	BYTE	1

(Field) parameters in Table 37 have the following assignment:

- OA characterizes appartenance of the transmitted essence;
- OT is an essence type, depending on its content. The following values are defined for this field:
 - a) 00 - internal software data ;
 - b) 01 - configuration parameters unit.
- MT is a type of module, the transmitted essence is intended for. The following values are defined for this field:
 - a) 00 - peripheral equipment;
 - b) 01 - VS.
- CMI is a component number, in case the essence belongs to VS, or an identifier of a peripheral module/port, connected to VS, depending upon MT parameter value;
- VER is a transmitted essence version (a high byte - a number before a point - major version, a low byte, after the point - minor version, e.g. 2.34 version will be presented with a number 0x0222);
- WOS - signature (a check sum) of the whole transmitted essence. CRC16-CCITT algorithm is used;
- FN is a transmitted essence file name (this field is optional and can have a zero length);
- D is a separation character of line parameters (its value is always 0).

4.7.4.2 EGT S_SR_SERVICE_FULL_DATA subrecord

A subrecord structure is given in Table 38.

Table 38 - EGT S_SR_SERVICE_FULL_DATA service subrecord structure
EGTS_FIRMWARE_SERVICE

Bit 7	Bit 6	Bit 5	Bit 4	Bit 3	Bit 2	Bit 1	Bit 0	Type	Data type	Size, bytes
ODH (Object Data Header)								M	BINARY	7...71
OD (Object Data)								M	BINARY	1...65400

(Field) parameters in Table 38 have the following assignment:

- ODH is a header with the parameters, characterizing a transmitted essence. ODH parameter is obligatory for EGT S_SR_SERVICE_FULL_DATA subrecord, each subrecord of this type includes this parameter;
- OD is the transmitted essence data.

4.7.4.3 EGT S_SR_RECORD_RESPONSE subrecord

This subrecord has the analogous structure, as described in cl. 4.7.2.1 and applied for confirmation of EGT S_SR_SERVICE_PART_DATA and EGT S_SR_SERVICE_FULL_DATA subrecords reception and processing. At that, a result code, equal to EGT S_PC_IN_PROGRESS, should be transmitted with EGT S_SR_RECORD_RESPONSE to all subrecords of EGT S_SR_SERVICE_PART_DATA type, but for the last one, if they are processed successfully. A subrecord

EGTS_SR_RECORD_RESPONSE with the code EGTS_PC_OK should be transmitted to the last EGTS_SR_SERVICE_PART_DATA and each EGTS_SR_SERVICE_FULL_DATA subrecords, in case of successful reception and processing by VS, then the service will accept it as a successful delivery attempt of the whole essence.

4.8 Time and quantitative variables of the service support protocol when using a data batch sending method

Time and quantitative parameters of the service support protocol are described in Table 39.

Table 39 - Time and quantitative parameters of the service support protocol

Name	Data type	Value range	Default value	Description
EGTS SL NOT_AUTHTO	BYTE	0 ... 255	6	Time of waiting for message reception from VS with data, required for authorization on the telematic platform side, after VS established a new TCP/IP protocol connection, (seconds). If the message is not received during this time, the platform should interrupt TCP/IP connection with VS.

5 Accident emergency response service of the service support protocol

5.1 Assignment of the accident emergency response service

An emergency response service is intended to ensure a basic service delivery by the ERA system. This service is defined as EGTS_ECALL_SERVICE with code 10 in the service support protocol.

5.2 A minimum set of VS functions, required for the use of EGTS_ECALL_SERVICE service

The in-vehicle emergency service call system can use the EGTS_ECALL_SERVICE service in VS, only if the following set of functions is implemented:

5.2.1 Support of EGTS_COMMANDS_SERVICE command processing service, specified in cl. 4.7.4.

5.2.2 Support of EGTSECALLREQ, EGTS_ECALL_MSD_REQ commands, sent by the ERA system operator via SMS and transmission of the corresponding answers and confirmations to them.

5.2.3 Processing of EGTS_TEST_MODE commands, sent by the system operator via GPRS and transmission of the corresponding answers and confirmations to them.

5.2.4 Acceleration profile data transmission via GPRS (EGTS_SR_ACCEL_DATA subrecord).

5.2.5 Transmission of vehicle trajectory data at the moment of road accident detection via GPRS (EGTS_SR_TRACK_DATA subrecord)

5.2.6 Processing of VS parameters setup commands, sent by the "ERA-GLONASS" system operator via GPRS and SMS, and transmission of the corresponding confirmations to them.

5.3 EGTS_ECALL_SERVICE service structure and subrecords description

In order to perform interaction in terms of EGTS_ECALL_SERVICE service several subrecords are used, their description and code are given in Table 40.

Table 40 - A list of subrecords of EGTS_ECALL_SERVICE service

Code	Name	Description
0	EGTS_SR_RECORD_RESPONSE	A subrecord is applied for confirmation of the service support protocol record from the EGTS_PT_APPDATA packet
20	EGTS_SR_ACCEL_DATA	The subrecord is intended for VS acceleration profile data transmission to the telematic platform.
50	EGTS_SR_MSD_DATA	VS uses the subrecord for MDS transmission to the telematic platform.

5.3.1 EGTS_SR_RECORD_RESPONSE subrecord

This subrecord has the analogous structure, as described in cl. 4.7.2.1.

5.3.2 EGTS_SR_ACCEL_DATA subrecord. A subrecord structure is given in Table 41

Table 41 - EGTS_SR_ACCELDATA service subrecord structure EGTS_ECALL_SERVICE

Bit 7	Bit 6	Bit 5	Bit 4	Bit 3	Bit 2	Bit 1	Bit 0	Type	Data type	Size, bytes
SA (StructuresAmount)								M	BYTE	1
ATM (AbsoluteTime)								M	UINT	4
ADS1 (Accelerometer Data Structure 1)								M	BINARY	8
ADS2 (Accelerometer Data Structure 2)								O	BINARY	8
...										
ADS255 (Accelerometer Data Structure 255)								O	BINARY	8

(Field) parameters in Table 41 have the following assignment:

- SA is a number of transmitted data structures of accelerometer readings;
- ATM is a period of measuring the first transmitted structure of accelerometer readings (seconds since 00:00:00 01.01.2010 UTC);
- ADS1 ... ADS255 - accelerometer readings data structures. A structure format is given in Table 42.

EGTS_SR_ACCELDATA subrecord should be transmitted including at least one ADS structure.

Table 42 - Format of accelerometer readings data structure of EGTS_ECALL_SERVICE service EGTS_SR_ACCELDATA subrecord

Bit 7	Bit 6	Bit 5	Bit 4	Bit 3	Bit 2	Bit 1	Bit 0	Type	Data type	Size, bytes
RTM (RelativeTime)								M	USHORT	2
XAAV (X Axis Acceleration Value)								M	SHORT	2
YAAV (Y Axis Acceleration Value)								M	SHORT	2
ZAAV (Z Axis Acceleration Value)								M	SHORT	2

(Field) parameters in Table 42 have the following assignment:

- RTM - increment of the previous record of measurement interval (increment to ATM field for the first record), in ms;
- XAAV - linear acceleration value along X axis (the high bit defines the symbol, 1 denotes to the negative value), 0.1 m/s ;
- YAAV - linear acceleration value along Y axis (the high bit defines the symbol, 1 denotes to the negative value), 0.1 m/s ;
- ZAAV - linear acceleration value along Z axis (the high bit defines the symbol, 1 denotes to the negative value), 0.1 m/s. Acceleration fields resolution should not exceed 0.01G.

5.3.4 EGTS_SR_MSD_DATA subrecord

EGTS_SR_MSD_DATA subrecord structure is given in Table 44 and meets requirements to MDS, specified.

Table 43 - EGTS_SR_MSD_DATA service subrecord structure EGTS_ECALL_SERVICE

Bit 7	Bit 6	Bit 5	Bit 4	Bit 3	Bit 2	Bit 1	Bit 0	Type	Data type	Size, bytes
FV (FormatVersion)								M	BYTE	1
MI (MessageIdentifier)								M	BYTE	1
CN (Control)								M	BYTE	1
-	VT(Vehicle Type)			POCN	CLT	ACT		-	-	-
VIN (Vehicle Identification Number)								M	STRING	17
VPST (Vehicle Propulsion Storage Type)								M	BYTE	1
TS (Time Stamp)								M	BINARY	4
PLAT (Position Latitude)								M	BINARY	4
PLON (Position Longitude)								M	BINARY	4
VD (Vehicle Direction)								M	BYTE	1
RVP n-1 LATD(Recent Vehicle Position n-1 Latitude Delta)								O	BINARY	2
RVP n-1 LOND(Recent Vehicle Position n-1 Longitude Delta)								O	BINARY	2
RVP n-2 LATD(Recent Vehicle Position n-2 Latitude Delta)								O	BINARY	2
RVP n-2 LOND(Recent Vehicle Position n-2 Longitude Delta)								O	BINARY	2
NOP (Number Of Passengers)								O	BYTE	1
AD (Additional Data)								O	STRING	0...56

(Field) parameters in Table 43 have the following assignment:

- FV is data format version (the field should contain 1);
- MI - message identifier (a field should contain value, starting with 1, and increment by 1, each time a message is sent after event occurrence);
- CN - a bit control field;
- VT - bit flags, characterizing a vehicle type [5]:

-
- a) 0001 - passenger (Category M1);
 - b) 0010 - bus (category M2);
 - c) 0011 - bus (category M3);
 - d) 0100 - a light truck (category N1);
 - e) 0101 - a heavy truck (category N2);
 - f) 0110 - a heavy truck (category N3);
 - g) 0111 - a bike (category L1e);
 - h) 1000 - a bike (category L2e);
 - i) 1001 - a bike (category L3e);
 - j) 1010 - a bike (category L4e);
 - k) 1011 - a bike (category L5e);
 - l) 1100 - a bike (category L6e);
 - m) 1101 - a bike (category L7e).
- POCN - (Position Confidence) a bit flag, defining location data validity:
- a) 1 - location data are not valid (if location cannot be defined with the accuracy of ± 150 m with 95% validity).
 - b) 0 - location data are valid.
- CLT - (Call Type) a bit flag, defining a call type:
- a) 1 - test call;
 - b) 0 - emergency call.
- ACT - (Activation Type) a bit flag, defining an event activation type:
- a) 1 - automatic;
 - b) 0 - manual.
- VIN is a vehicle identifier;
- VPST is a vehicle energy material type:
- a) if all bits are set to 0, the type is not assigned;
 - b) Bit 7: 6 - not used;
 - c) Bit 5: 1 - nitrogen;
 - d) Bit 4: 1 - electricity (over 42V and 100 A/h);
 - e) Bit 3: 1 - liquid propane (LPG);
 - f) Bit 2: 1 - compressed natural gas (CNG);
 - g) Bit 1: 1 - diesel; h) Bit 0: 1 - gasoline.
- TS is an event time. Time in seconds since 00:00:00 01.01.1970 according to the universal coordinated time (UTC). If the event time cannot be defined it is set to 0. This field should be interpreted on receiving side, as UINT type with the byte ordering big-endian;
- PLAT is vehicle location latitude at the event moment in angle ms. If there is no latitude value or it cannot be defined, all field bits should be set to 1. This field should be interpreted on receiving side, as INT type with the byte ordering big-endian;

- PLON is a vehicle location longitude at the event moment in angle ms. If there is no latitude value or it cannot be defined, all field bits should be set to 1. This field should be interpreted on receiving side, as INT type with the byte ordering big-endian;

- VD is a vehicle movement direction clockwise from the north magnetic pole direction at a 2° pitch. A possible value range is 0 ... 129. When a value cannot be defined, the field should contain 255;

- RVP n-1 LATD is a difference of vehicle location latitude against PLAT field value at a 100 ms pitch. Positive values are located northward, negative - southward. A possible value range is from minus 512 to plus 511. If there is no value or it cannot be defined, all field bits should be set to 1. This field should be interpreted on receiving side, as SHORT type with the byte ordering big-endian;

- RVP n-1 LOND is a difference of the vehicle location longitude against PLON field value at a pitch, specified in GOST R 54620 (Appendix C). Positive values are located eastwardly, negative - westward. A possible value range is from minus 512 to plus 511. If there is no value or it cannot be defined, all field bits should be set to 1. This field should be interpreted on receiving side, as SHORT type with the byte ordering big-endian;

- RVP n-2 LATD is a difference of the vehicle location latitude against RVP n-1 LATD field value at a pitch, specified in GOST R 54620 (Appendix C). Positive values are located northward, negative - southward. A possible value range is from minus 512 to plus 511. If there is no value or it cannot be defined, all field bits should be set to 1. This field should be interpreted on receiving side, as SHORT type with the byte ordering big-endian;

- RVP n-2 LOND is a difference of the vehicle location longitude against RVP n-1 LOND field value at a pitch, specified in GOST R 54620 (Appendix C). Positive values are located eastwardly, negative - westward. A possible value range is from minus 512 to plus 511. If there is no value or it cannot be defined, all field bits should be set to 1. This field should be interpreted on receiving side, as SHORT type with the byte ordering big-endian;

- NOP is a number of buckled safety belts. If there is no data, the field should contain 255;

- AD - additional data.

Optional parameters required in EGTS_SR_MSD_DATA subrecord should be defined proceeding from the total subrecord size. Upon that, if it is required to transmit an optional parameter, for example NOP field, then all previous optional fields - RVP n-1 LATD, RVP n-1 LOND, RVP n-2 LATD, and RVP n-2 LOND should also be transmitted with the corresponding filling data.

5.4 EGTS_COMMANDS_SERVICE

Table 44 - A VS command list

Name of command	Code	Type, number and parameters threshold values	Description
EGTS_ECALL_REQ	0x0112	BYTE/0.1	Emergency call execution command. Over SMS only. This command has a single parameter that specifies an event type: 0 - manual call, or 1 - automatic call.
EGTS_TEST_MODE_START_TEST	0x0003	BYTE/ 0...8	This command starts tests in the "test mode". It can take the following values: 0 - starting all tests one by one; 1 - call centre testing; 2 - external (commercial) call centre testing; 3 - microphone testing;

Table 45 - A list of VS confirmations to commands and messages

Command name	Code	Parameters type and number	Description
EGTS_TEST_MODE_START_TEST	0x0003	BINARY (8 bytes)	Test results. Each byte contains a code, which determines a test result (see description of TEST_MODE_START_TEST in Table 35). 1st byte - test 1, 2nd byte - test 2, etc.

Table 46 – VS parameter list

General purpose settings						
EGTS_ECALL_BLOCK_LIST	0x0206	ARRAY OF STRING	<pre> " </pre>	List of networks that not allow emergency call initiation	SEC, SBS, SOS	Yes
EGTS_ECALL_TEST_NUMBER	0x020D	STRING	" "	Phone number for ERA-GLONASS test calls	SEC, SBS, SOS	Yes
Configuration and service configuration data						
Basic ERA-GLONASS service						
EGTS_ECALL_ON	0x0210	BOOLEAN	TRUE	Possibility of emergency call initiation	SEC, SBS, SOS	Yes
EGTS_ECALL_CRASH_SIGNAL_INTERNAL	0x0211	BOOLEAN	TRUE	M1 category vehicles only: crash events are detected using a built-in accelerometer	SEC	Yes
EGTS_ECALL_CRASH_SIGNAL_EXTERNAL	0x0212	BOOLEAN	TRUE	M1 category vehicles only: crash events are detected using an external sensor	SEC	Yes
EGTS_ECALL_SOS_BUTTON_TIME	0x0213	INT	200	Emergency button press-and-hold duration required to initialize an emergency call regardless of the condition of the ignition line (ms)	SEC	Yes
EGTS_ECALL_MODE_PIN	0x0216	INT/0...8	0	Line used for sending a signal indicating that the system is in the ERA mode:	SEC	Yes

				NONE – no mode signaling; X – PIN_X line that is active, when the system is in this mode.		
EGTS_ECALL_CCFT	0x0217	INT	60	Automatic call termination time-out (min)	SEC, SBS, SOS	Yes
EGTS_ECALL_INVITATION_SIGNAL_DURATION	0x0218	INT	200	INVITATION signal duration (ms)	SEC, SBS, SOS	Yes
EGTS_ECALL_SEND_MSG_PERIOD	0x0219	INT	200	SEND MSG message interval (ms)	SEC, SBS, SOS	Yes
EGTS_ECALL_AL_ACK_PERIOD	0x021A	INT	200	AL-ACK interval (ms)	SEC, SBS, SOS	Yes
EGTS_ECALL_MS_D_MAX_TRANSMISSION_TIME	0x021B	INT	20	Maximum MSD transmission time (s)	SEC, SBS, SOS	Yes
EGTS_ECALL_NAD_DEREGISTRATION_TIMER	0x021D	INT	8	Delay before a GSM or UMTS module de-registers from a network (h)	SEC, SBS, SOS	Yes
EGTS_ECALL_DIAL_DURATION	0x021E	INT	5	Automatic redial duration when making emergency calls (min)	SEC, SBS, SOS	Yes
EGTS_ECALL_AUTO_DIAL_ATTEMPTS	0x021F	INT	10	M1 category vehicles only: Maximum number of dial attempts in case of automatic emergency call initialization. This value cannot be set to 0.	SEC, SBS, SOS	Yes
EGTS_ECALL_MANUAL_DIAL_ATTEMPTS	0x0220	INT	10	Maximum number of dial attempts in case of manual emergency call initialization. This value cannot be set to 0.	SEC, SBS, SOS	Yes
EGTS_ECALL_MANUAL_CANCEL	0x0222	BOOLEAN	TRUE	TRUE – a manually initialized emergency call can be terminated by user	SEC, SBS, SOS	Yes
EGTS_ECALL_SMS_FALLBACK_NUMBER	0x0223	STRING	“112”	Phone number for sending SMS messages containing minimum datasets on a system operator’s request	SEC, SBS, SOS	Yes
Acceleration profile recording in case of road accidents						
IGNITION_OFF_FOLLOW_UP_TIME_1	0x0224	INT	120	Duration of acceleration profile recording upon a crash event with ignition switched off (min)	SEC	Yes
IGNITION_OFF_FOLLOW_UP_TIME_2	0x0224	INT	240	Duration of crash event detection upon a crash event with ignition switched off (min)	SEC	Yes
EGTS_CRASH_RECORD_TIME	0x251	INT/0..250	250	Duration of post-crash acceleration profile recording (ms)	SEC	Yes
EGTS_CRASH_RECORD_RESOLUTION	0x0252	INT/1...5	1	Resolution of post-crash acceleration profile recording (ms)	SEC	Yes
EGTS_CRASH_PRE_RECORD_TIME	0x0253	INT/0...20000	20000	Duration of pre-crash acceleration profile recording (ms)	SEC	Yes
EGTS_CRASH_PRE_RECORD_RESOLUTION	0x0254	INT/5...100	5	Resolution of pre-crash acceleration profile recording (ms)	SEC	Yes

LUTION						
Motion trajectory recording in case of road accidents						
EGTS_TRACK_RECORD_TIME	0x025A	INT/0..180	10	Duration of post-crash motion trajectory recording (s). If this parameter has a value of 0, post-crash motion trajectory recording is not performed.	SEC	Yes
EGTS_TRACK_PRE_RECORD_TIME	0x025B	INT/0...600	20	Duration of pre-crash motion trajectory recording (s). If this parameter has a value of 0, pre-crash motion trajectory recording is not performed.	SEC	Yes
EGTS_TRACK_RECORD_RESOLUTION	0x025C	INT/1...30	10	Resolution of motion trajectory recording (100 ms)	SEC	Yes
Vehicle parameters						
EGTS_VEHICLE_VIN	0x0311	STRING	""	VIN as per cl. [5]	SEC, SBS, SOS	Yes
EGTS_VEHICLE_TYPE	0x0312	INT	0	Vehicle type: 1 - passenger car, class M1 2 - bus, class M2 3 - bus, class M3 4 - light truck, class N1 5 - heavy truck, class N2 6 - heavy truck, class N3 7 - motorbike, class L1e 8 - motorbike, class L2e 9 - motorbike, class L3e 10 - motorbike, class L4e 11 - motorbike, class L5e 12 - motorbike, class L6e 13 - motorbike, class L7e	SEC, SBS, SOS	Yes
EGTS_VEHICLE_PROPULSION_STORAGE_TYPE	0x0313	INT	0	Energy source type. If all bits have a value of 0, energy source type is not defined Bit 7: unused Bit 6: unused Bit 5: 1 - hydrogen Bit 4: 1 - electricity (over 42 V and 100 Ah) Bit 3: 1 - liquid propane (LPG) Bit 2: 1 - liquified natural gas (CNG) Bit 1: 1 - diesel Bit 0: 1 - gasoline	SEC, SBS, SOS	

Annex 10 - Appendix A

Description of a navigation and information system designconcept on a transport protocol basis

Telematic platform is a minimum sufficient unit, of the system, using the transport protocol. A "dispatch operator" notion is used as a main component of the telematic platform, coordinating routing and interaction inside the platform.

The protocol distinguishes a logic level of routing between platforms, which provides for data (data packets) transmission between different telematic platforms, and the internal platform routing, where data are transmitted between various services of one platform. "Service" is regarded as a telematic platform component, providing for functioning of one or the other service algorithm with the use of the described transport protocol. In all mentioned types of routing interaction involves a dispatcher.

In the system, based on transport protocol, services that build up data packets on sending side and process received packets on receiving side are data generators and consumers. Each service implements different business logic depending on functionality of one or another service. A type of service is its main functional characteristic, used by a dispatcher for data routing inside the platform. As a rule, a complementary couple of services participate in interaction: one of them is located on the subscriber's terminal side (in the current standard it is VS or "ERA-GLONASS" terminal) and builds up packets with coordinates and sensor readings, and the other one is on the telematic platform side, it processes such data. All services within a telematic platform are linked with a dispatcher and do not get in touch with each other.

A telematic platform can maintain connections with other platforms and exchange data messages based on routing data. To perform routing, a dispatcher turns to the local storage, where data about nearby telematic platforms, their available services, and data about services available inside the home platform are contained. If dispatchers of different telematic platforms are linked, they can share data about types of services, available to each side, and their status. A route search is limited to a direction (connection) search on the type of requested service. If the requested service is on one telematic platform with the dispatcher, interaction involves only intraplatform routing. Thus, if there are corresponding permits, a service search is performed according to the routing data of nearby telematic platforms, when such route location is found and available, a request is sent to the found platform, using a remote platform dispatcher's identifier as an address.

VS also cooperated with the telematic platform services via dispatcher. In this case VS is identified according to specific packets with a unique VS number, assigned to it during a system registration, and other registration data and information about internal equipment and VS modules and units condition.

A structural diagram, showing system components cooperation, based on transport protocol described, is provided on Figure A.1. Each service has a certain type, determined by SID parameter on Figure A 1.

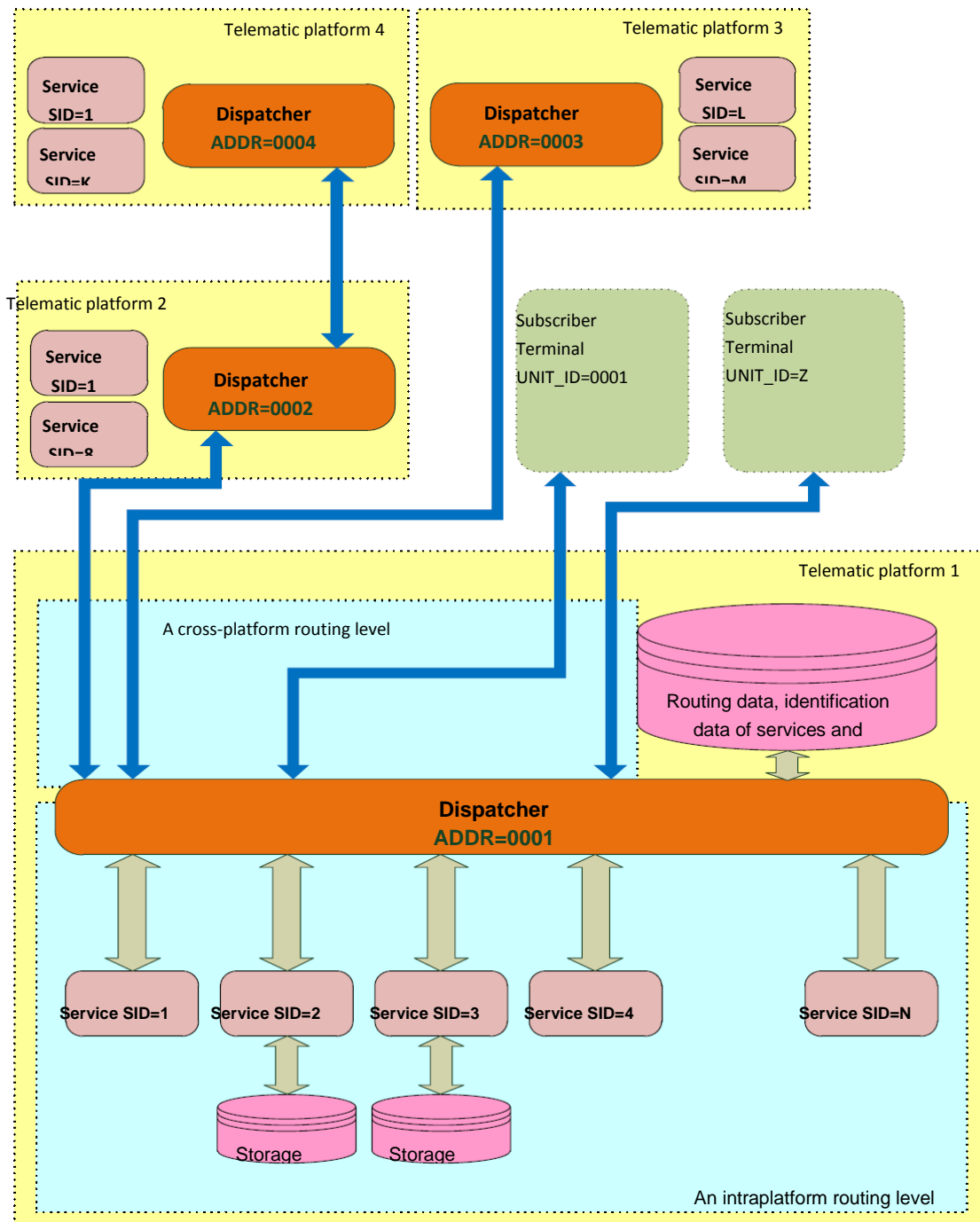

Figure A.1 - A structural diagram of system components cooperation, based on the transport protocol

Annex 10 - Appendix B

Transport protocol analysis based on NGTP concept

According to the design concept of telematic platforms based on NGTP, three basic cooperation components are distinguished: a telematic device, a telematic service provider and a dispatcher. They cooperate via standardized interfaces and are the protocol elements, excluding the telematic service provider, which is united with a dispatcher in the protocol.

A telematic device (in respect to the current standard it is the in-vehicle emergency service call system "ERA-GLONASS") is integrated into the vehicle, but can also be used as a personal navigation device or a mobile phone.

A telematic service provider is intended for data exchange between services and telematic devices.

According to NGTP a dispatcher is an agent between a TSP and AP, and provides for a standard communication interface of TD with the other system components, ensuring service functions performance. A dispatcher uses only its level data and does not analyse service level data structure.

NGTP header fully coincides with the first bytes of the transport protocol header: Protocol Version (1 byte), Security Context (2 bytes), NGTP HeaderLength (1 byte), NGTP Header Encoding (1 byte)

VS identifier in NGTP is VIN /DriveID, in the described protocol it is UNITID.

For identification of VS in a standard equipment configuration VIN is used.

Like NGTP, the protocol is focused on a flexible service data routing between VS and a telematic platform. Upon that, a new service implementation does not require protocol refinement, since protocol performs data routing only, and processing is done in the service itself. It is necessary to set a correct dispatcher routing to a new service type, which is performed by system administration tools, based on the transport protocol.

NGTP uses the "event" notion, defining a certain general data characteristic and intended for different data types integration into a summary data array. Each event identifier has an attribute, identifying the event generation time. Such integration mechanism usage is put into a transport protocol, where each service support protocol record can contain an event identifier, generated by the source of such records in a certain time period, for example, when a road accident happens.

Unlike NGTP, which uses different interfaces between TD and a dispatcher, a dispatcher and TSP, and between TSP and services, a VS transport protocol uses one interface for components connection.

NGTP uses a "trigger" notion, which implies a system components notification about data, received for them. When such "trigger" is accepted, the data receiver should make a request for these data and process them. "Triggers" are not used in the transport protocol, and data are immediately sent to a receiver.

Annex 10 - Appendix C

Processing result codes

Processing result codes are provided in Table C.1.

Table C.1 - Processing result codes

Value	Symbols	Description
0	EGTS_PC_OK	Successfully processed
1	EGTS_PC_IN_PROGRESS	Being processed (processing result is unknown)
128	EGTSPCUNSPROTOCOL	Unsupported protocol
129	EGTS_PC_DECRYPT_ERROR	Decoding error
130	EGTS_PC_PROC_DENIED	Processing is restricted
131	EGTSPCINCHEADERFORM	Header format error
132	EGTSPCINCDATAFORM	Data format error
133	EGTS_PC_UNNS_TYPE	Unsupported type
134	EGTS_PC_NOTEN_PARAMS	Parameters amount error
135	EGTS_PC_DBL_PROC	Reprocessing attempt
136	EGTS_PC_PROC_SRC_DENIED	Source data processing is prohibited
137	EGTS_PC_HEADERCRC_ERROR	A header check sum error
138	EGTS_PC_DATACRC_ERROR	A data check sum error
139	EGTSPCINVDATALEN	Invalid data length
140	EGTS_PC_ROUTE_NFOUND	Route is not found
141	EGTS_PC_ROUTE_CLOSED	Route is closed
142	EGTS_PC_ROUTE_DENIED	Routing is forbidden
143	EGTSPCINVADDR	Address error
144	EGTS_PC_TTLEXPRIED	Retransmitted data exceeding
145	EGTS_PC_NO_ACK	Not confirmed
146	EGTS_PC_OBJ_NFOUND	Object is not found
147	EGTS_PC_EVNT_NFOUND	Event is not found
148	EGTS_PC_SRVC_NFOUND	Service is not found
149	EGTS_PC_SRVC_DENIED	Service is prohibited
150	EGTS_PC_SRVC_UNKN	Unknown type of service
151	EGTS_PC_AUTH_DENIED	Authorization is prohibited
152	EGTS_PC_ALREADY_EXISTS	Object already exists
153	EGTS_PC_ID_NFOUND	Identifier is not found
154	EGTSPCINCDATETIME	Data and time error
155	EGTS_PC_IO_ERROR	Input/output error
156	EGTS_PC_NO_RES_AVAIL	Insufficient resources
157	EGTS_PC_MODULE_FAULT	Internal module failure
158	EGTS_PC_MODULE_PWR_FLT	Module power circuit failure
159	EGTS_PC_MODULE_PROC_FLT	Module microcontroller failure
160	EGTS_PC_MODULE_SW_FLT	Module program failure
161	EGTS_PC_MODULE_FW_FLT	Module software error
162	EGTS_PC_MODULE_IO_FLT	Module I/O unit fault
163	EGTS_PC_MODULE_MEM_FLT	Module internal memory fault
164	EGTS_PC_TEST_FAILED	Test failed

Annex 10 - Appendix D

An example of C CRC16 check sum computation algorithm implementation

Name : CRC-16 CCITT

Poly : $0x1021 x^{16} + x^{12} + x^5 + 1$

Init : 0xFFFF

Revert: false

XorOut: 0x0000

Check : 0x29B1 ("123456789")*/

```
const unsigned short Crc16Table[256] - {
0x0000, 0x1021, 0x2042, 0x3063, 0x4084, 0x50A5, 0x60C6, 0x70E7,
0x8108, 0x9129, 0xA14A, 0xB16B, 0xC18C, 0xD1AD, 0xE1CE, 0xF1EF,
0x1231, 0x0210, 0x3273, 0x2252, 0x52B5, 0x4294, 0x72F7, 0x62D6,
0x9339, 0x8318, 0xB37B, 0xA35A, 0xD3BD, 0xC39C, 0xF3FF, 0xE3DE,
0x2462, 0x3443, 0x0420, 0x1401, 0x64E6, 0x74C7, 0x44A4, 0x5485,
0xA56A, 0xB54B, 0x8528, 0x9509, 0xE5EE, 0xF5CF, 0xC5AC, 0xD58D,
0x3653, 0x2672, 0x1611, 0x0630, 0x76D7, 0x66F6, 0x5695, 0x46B4,
0xB75B, 0xA77A, 0x9719, 0x8738, 0xF7DF, 0xE7FE, 0xD79D, 0xC7BC,
0x48C4, 0x58E5, 0x6886, 0x78A7, 0x0840, 0x1861, 0x2802, 0x3823,
0xC9CC, 0xD9ED, 0xE98E, 0xF9AF, 0x8948, 0x9969, 0xA90A, 0xB92B,
0x5AF5, 0x4AD4, 0x7AB7, 0x6A96, 0x1A71, 0x0A50, 0x3A33, 0x2A12,
0xDBFD, 0xCBDC, 0xFBBF, 0xEB9E, 0x9B79, 0x8B58, 0xBB3B, 0xAB1A,
0x6CA6, 0x7C87, 0x4CE4, 0x5CC5, 0x2C22, 0x3C03, 0x0C60, 0x1C41,
0xEDAE, 0xFD8F, 0xCDEC, 0xDDCD, 0xAD2A, 0xBD0B, 0x8D68, 0x9D49,
0x7E97, 0x6EB6, 0x5ED5, 0x4EF4, 0x3E13, 0x2E32, 0x1E51, 0x0E70,
0xFF9F, 0xEFBE, 0xDFDD, 0xCFFC, 0xBF1B, 0xAF3A, 0x9F59, 0x8F78,
0x9188, 0x81A9, 0xB1CA, 0xA1EB, 0xD10C, 0xC12D, 0xF14E, 0xE16F,
0x1080, 0x00A1, 0x30C2, 0x20E3, 0x5004, 0x4025, 0x7046, 0x6067,
0x83B9, 0x9398, 0xA3FB, 0xB3DA, 0xC33D, 0xD31C, 0xE37F, 0xF35E,
0x02B1, 0x1290, 0x22F3, 0x32D2, 0x4235, 0x5214, 0x6277, 0x7256,
0xB5EA, 0xA5CB, 0x95A8, 0x8589, 0xF56E, 0xE54F, 0xD52C, 0xC50D,
0x34E2, 0x24C3, 0x14A0, 0x0481, 0x7466, 0x6447, 0x5424, 0x4405,
0xA7DB, 0xB7FA, 0x8799, 0x97B8, 0xE75F, 0xF77E, 0xC71D, 0xD73C,
0x26D3, 0x36F2, 0x0691, 0x16B0, 0x6657, 0x7676, 0x4615, 0x5634,
0xD94C, 0xC96D, 0xF90E, 0xE92F, 0x99C8, 0x89E9, 0xB98A, 0xA9AB,
0x5844, 0x4865, 0x7806, 0x6827, 0x18C0, 0x08E1, 0x3882, 0x28A3,
0xCB7D, 0xDB5C, 0xEB3F, 0xFB1E, 0x8BF9, 0x9BD8, 0xABBB, 0xBB9A,
0x4A75, 0x5A54, 0x6A37, 0x7A16, 0x0AF1, 0x1AD0, 0x2AB3, 0x3A92,
0xFD2E, 0xED0F, 0xDD6C, 0xCD4D, 0xBDAA, 0xAD8B, 0x9DE8, 0x8DC9,
0x7C26, 0x6C07, 0x5C64, 0x4C45, 0x3CA2, 0x2C83, 0x1CE0, 0x0CC1,
```

```
0xEF1F, 0xFF3E, 0xCF5D, 0xDF7C, 0xAF9B, 0xBFBA, 0x8FD9, 0x9FF8,  
0x6E17, 0x7E36, 0x4E55, 0x5E74, 0x2E93, 0x3EB2, 0x0ED1, 0x1EF0};  
unsigned short Crc16(unsigned char * pcBlock, unsigned short len)  
{ unsigned short crc = 0xFFFF;  
while (len--)  
  crc = (crc << 8) л Crc16Table[(crc >> 8) ^ *pcBlock++];  
return crc;}
```

Literature list

- [1] RFC1323: "TCP Extensions for High Performance"
- [2] GSM 03.38 (ETS 300 628): "Digital cellular telecommunication system (Phase 2); Alphabets and language-specific information".
- [3] GSM 03.40 (ETS 300 536): "Digital cellular telecommunication system (Phase 2); Technical realization of the Short Message Service (SMS) Point to Point (PP)".
- [4] ISO 639-2 Codes for the Representation of Names of Languages Part 2: Alpha-3 Code
- [5] ITU-T E.164 The international public telecommunication numbering plan.
- [6] EN 15722 Transport and traffic telematics – Emergency safety _The minimum data set.

]

Functional diagnostics tests

1. Definitions

1.1 “*Minimum data set*” – A data set, sent by the in-vehicle emergency call system/device system in case of a road accident, which contains data concerning vehicle coordinates and movement of the vehicle, VIN-code and other information, required for emergency response.

2. General principles

Function tests of the In-Vehicle Emergency Call System/Device include the following:

- the In-Vehicle Emergency Call System/Device compliance assessment for function requirements (sec.4.1 – 4.12);
- the In-Vehicle Emergency Call System/Device compliance assessment for Data sending protocol requirements (sec.4.13 – 4.20).

2.1. To conduct the function tests at least 3 In-Vehicle Emergency Call System/Device samples shall be presented.

2.2. In-Vehicle Emergency Call System/Devices are provided for the tests with a set SIM-card.

3. Test conditions

3.1. Function tests of the In-Vehicle Emergency Call System/Device are conducted in normal climate conditions:

- ambient air temperature – $(25 \pm 10)^\circ\text{C}$;
- relative humidity - from 45% to 80 %;
- bar pressure - from 84,0 to 106,7 kPa (630 - 800 mHg.).

3.2. Function tests of the In-Vehicle Emergency Call System/Device are conducted on the stand, organised according to the diagram, given in Figure 1.

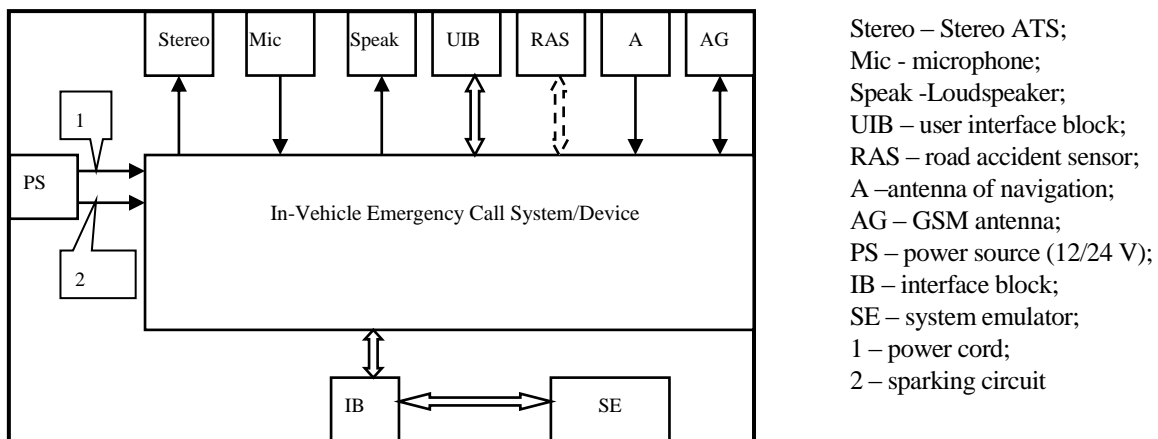

Figure 1. General diagram of VS connection

3.3. The stand consists of:

- A system emulator, which allow configuration and testing of the In-Vehicle Emergency Call System/Device, with capacity to receive-transmit necessary data (via the in-band modem, SMS and batch communication), test results interpretation;
- peripheral devices, antennas and other devices intended for simulation of conditions of the In-Vehicle Emergency Call System/Device use.

3.4. The list of test and ancillary equipment for function tests is given in Table 1

Table 1. Test and ancillary equipment

Equipment name	Required technical characteristics of devices and equipment
Test stand	Figure 1
Oscilloscope	Band to 100 MHz. Precision 3 %
Electrical tester	Voltage range to 500 V, resistance 2M Ω
Power source	Out voltage from 0 to 30 V, Pick load current 10 A
PC	External interface – USB 2.0
Metallic shield	Plain, steel, size 500x500x2 mm

3.5. “Emergency call” can be conducted both manually and automatically during the test by means of:

- pushing the “ Emergency call ” button manually;
- automatically, by means of imitation operational conditions devices.

3.6. For the In-Vehicle Emergency Call System/Device, performed as additional equipment the In-Vehicle Emergency Call System/Device test starts by pushing the “Additional functions” button.

3.7. For the In-Vehicle Emergency Call System/Device, performed as base equipment the In-Vehicle Emergency Call System/Device test starts in accordance with user’ manual.

3.8. Settings, configuration and obtaining values of the current configuration settings of the In-Vehicle Emergency Call System/Device are performed in accordance with operation manual.

3.9. Check of telephone numbers, set for the In-Vehicle Emergency Call System/Device, for implementation of the emergency call in the test mode, is carried out by means of the diagnostic software in a mode of check parameters set.

3.10. Minimum data set is successfully decoded, if it contains correct data: vehicle VIN-code, type of the vehicle, power source type, information on geographical location of the vehicle and time of road accident, the correct marker of the emergency call activation – automatic or manual activation.

3.11. Prior the test it is necessary to make certain, that:

- the In-Vehicle Emergency Call System/Device is connected to the stand in accordance with the diagram, given in Figure 1;
- the correct telephone number is set in the In-Vehicle Emergency Call System/Device for the implementation of an emergency call (for the test mode the number shall be set the system operator);
- the antennas providing receiving of satellite signals during the tests are located so that no constructions cause screening influence on them.

4. Test procedure

4.1. Minimum data set transmission test

4.1.1. For the Minimum data set transmission test via the in-band modem to imitate an emergency call automatically and manually.

4.1.2. For the Minimum data set transmission test via SMS, with the help of emulator to disable the opportunity of receiving data via the in-band modem and to imitate an emergency call automatically and manually. To make sure that voice connection is set but there is no correct receiving data via the in-band modem.

4.1.3. The In-Vehicle Emergency Call System/Device is considered to have passed the test and is able to transmit the Minimum data set, if following actions are successfully completed:

- data via the in-band modem and SMS were received in automatic and manual mode in 20 sec.
- the minimum data set is successfully decoded in all modes.

4.2. The check for transmission of vehicle location information at a road accident moment.

4.2.1. To set emulator interface for the view of data receiving results about the road accident.

4.2.2. By means of the diagnostic software to make sure that the correct number for the emergency call in test mode is set.

4.2.3. To imitate an emergency call automatically for each condition as for the road accident moment:

- vehicle location is unknown;
- only last vehicle location is known;
- expected vehicle location is known;
- movement direction of vehicle is known.

4.2.4. The In-Vehicle Emergency Call System/Device is considered to have passed the test and is able to transmit the information on vehicle location for the road accident moment if following actions are completed successfully:

- data received via the in-band modem in 20 sec from the beginning of transmission;
- minimum data set is successfully decoded, vehicle VIN-code, type of the vehicle, power source type, time of road accident, information on geographical location of the vehicle: coordinates, information on the last known location, on the expected vehicle location and movement direction, depending on set signal parameters.

4.2.5. In case if for the moment of data generation there is no reliable information on the last known vehicle location, the mark “no reliable information on vehicles location” shall be included in data set.

4.3. Check of providing a public address in case of an emergency call

4.3.1. To give the external power supply on the In-Vehicle Emergency Call System/Device and a signal “Ignition” on the line enter of vehicles ignition.

4.3.2. To record the absence of “forbid a sound” signal at the disconnection exit of car stereo by means of Oscilloscope.

4.3.3. With the help of diagnostic software to make sure that that the correct number for the emergency call in test mode is set.

4.3.4. By pushing the “Emergency call” button to establish a two-way voice connection.

4.3.5. To record the “forbid a sound” signal at the disconnection exit of car.

4.3.6. To disconnect the emergency call.

4.3.7. To record the absence of “forbid a sound” signal at the disconnection exit of car.

4.3.8. The In-Vehicle Emergency Call System/Device is considered to have passed the test and is able to provide public address during the emergency call, if by initialization of the “Emergency call” a two-way voice connection is established and all sound reproducer are disabled

4.3.9. For the In-Vehicle Emergency Call System/Device provided as base equipment the establishment of two-way voice connection, presupposing the disabling of all sound producers is defined by the vehicle manufacturer

4.4. The check of the In-Vehicle Emergency Call System/Device test mode.

4.4.1. To make sure that the interface for viewing results of data receiving of the In-Vehicle Emergency Call System/Device test.

4.4.2. To enable the In-Vehicle Emergency Call System/Device

4.4.3. By means of diagnostic software to assure that the correct phone number ECALL_TEST_NUMBER is set in the In-Vehicle Emergency Call System/Device and to set the Network registration period after completing the test TEST_REGISTRATION_PERIOD – 5 min.

4.4.4. On the party of the In-Vehicle Emergency Call System/Device initiate a request signal for the test mode.

4.4.5. To check:

- microphone connection
- loudspeaker (loudspeakers) connection
- shutdown/starting ignition
- detailed users interface block test
- sufficient state of standby battery (if there is a technical possibility)
- workability of sensor of automatic identification of road accident
- consistency of software image
- receiver workability

4.4.6. By means of emulator users interface to make sure that minimum data set with the test results is successfully transmitted to the number ECALL_TEST_NUMBER and contains the correct information.

4.4.7. Making sure that the test is successfully completed by means of voice prompt or by state indicator, to disable external power source of In-Vehicle Emergency Call System/Device and disconnect the loudspeaker.

4.4.10. To enable external power source of the In-Vehicle Emergency Call System/Device

4.4.11. To initiate a request signal for the test mode on the party of the In-Vehicle Emergency Call System/Device.

4.4.12. To make sure by means of emulator users interface, that minimum data set with the test results is successfully transmitted to the number ECALL_TEST_NUMBER and contains information on malfunction and there is indication “Malfunction” on users interface block.

4.5. The In-Vehicle Emergency Call System/Device state indicators test in additional equipment configuration

4.5.1. To give the external power supply on the In-Vehicle Emergency Call System/Device or to give the signal “Ignition” to line enter of ignition, and to make sure that the state indicator of the In-Vehicle Emergency Call System/Device indicates operational condition for a short moment (from 3 to 10 sec.).

4.5.2. To make sure by means of diagnostic software that the correct phone number is set for the emergency call in test mode.

-
- 4.5.3. To establish a two-way voice connection by pushing the “Emergency call” button to establish.
- 4.5.4. To make sure that the two-way voice connection is set and the state indicator of the In-Vehicle Emergency Call System/Device indicates states: “Emergency call”, “Dialing in a emergency call mode”, “Minimum data set transmission in emergency call mode”.
- 4.5.5. To make sure by means of emulator users interface that following actions are successfully completed:
- data via in-band modem were received within 20 sec.
 - minimum data set is decoded.
- 4.5.6. To terminate the emergency call and to make sure that the state indicator does not indicates “Emergency call”.
- 4.5.7. To set the parameter ECALL_ON to FALSE by means of diagnostic software of the In-Vehicle Emergency Call System/Device.
- 4.5.7. To imitate the emergency call in automatic mode.
- 4.5.8. To make sure that in the emulator users interface for the viewing of data receiving, in the in-band modem and in data decoding no changes happened, and the state indicator of the In-Vehicle Emergency Call System/Device indicates “Emergency call is impossible”.
- 4.5.9. To disable the In-Vehicle Emergency Call System/Device power source and to disconnect external GSM/UMTS antenna or navigation satellite system antenna (if the external antenna is included), or disconnect the microphone (if there is such possibility).
- 4.5.10. To give the external power supply on the In-Vehicle Emergency Call System/Device or to give the signal “Ignition” to line enter of ignition, and to make sure that the state indicator of the In-Vehicle Emergency Call System/Device indicates “Malfunction”
- 4.5.11. Take the signal “Ignition” off the line enter of ignition or disable the In-Vehicle Emergency Call System/Device power source.
- 4.5.12. To connect the GSM/UMTS antenna or navigation satellite antenna (if it was disconnected before) or to connect the microphone (if it was disconnected before).
- 4.5.13. To give the external power supply on the In-Vehicle Emergency Call System/Device or to give the signal “Ignition” to line enter of ignition, and to make sure that the state indicator of the In-Vehicle Emergency Call System/Device does not indicates “Malfunction”.
- 4.5.14. To give the signal “Ignition” off the line enter of ignition or to enable the In-Vehicle Emergency Call System/Device power source.
- 4.5.15. To make sure that the correct number for test calls ECALL_TEST_NUMBER is set in the In-Vehicle Emergency Call System/Device.
- 4.5.16. To run the test mode.
- 4.5.17. To make sure that the state indicator of the In-Vehicle Emergency Call System/Device indicates «Test mode».
- 4.5.18. To disable external power source of the In-Vehicle Emergency Call System/Device or to take off the “Ignition” signal from the line enter of ignition.
- 4.5.19. To give the external power source on the In-Vehicle Emergency Call System/Device.
- 4.5.20. To imitate the emergency call in test mode.
- 4.5.21. To make sure, that emulator users interface displays information on receiving the maximum set of event messages, and the state indicator displays «Overfilling of entire events memory » or «Malfunction».
- 4.5.22. To clean the operating storage by means of diagnostic software of the In-Vehicle Emergency Call System/Device.
- 4.5.23. To imitate the emergency call in automatic mode.

4.5.24. To make sure by means of emulator users interface that following actions are completed successfully:

- data was received within 20 sec. via the in-band modem
- minimum data set decoded.

4.5.25. To terminate the emergency call and to make sure, that the state indicator of the In-Vehicle Emergency Call System/Device indicates «Car service».

4.5.26. To disable external power source of the In-Vehicle Emergency Call System/Device and to discharge a standby battery or to change to the discharged one (in case of existence of the standby battery).

4.5.27. To make sure, that the state indicator of the In-Vehicle Emergency Call System/Device indicates «The charge of standby battery is below the stated limit» or «Malfunction».

4.5.28. The In-Vehicle Emergency Call System/Device is considered to have passed state indicators test if in all tests conducted in sec.4.5.1 – 4.5.27 state indicators were displayed correctly.

4.6. The check of the In-Vehicle Emergency Call System/Device operability in additional equipment configuration in “Car service” mode

4.6.1. To enable the «Car service» mode, in accordance with an Instruction of the In-Vehicle Emergency Call System/Device use.

4.6.2. To measure level of tension of the physical line GARAGE_MODE_PIN and to compare to an indicator declared in the Instruction of the In-Vehicle Emergency Call System/Device use.

4.6.3. To imitate the “Emergency call” manually.

4.6.4. To make sure that in the emulator users interface for the viewing of data receiving, in the in-band modem and in data decoding no changes happened.

4.6.4. To quit the «Car service» mode, in accordance with a user’ guide.

4.6.5. To measure level of tension of the physical line GARAGE_MODE_PIN, to make sure in its absence in the line.

4.6.6. To imitate the “Emergency call” manually.

4.6.7. To make sure by means of emulator users interface that the minimum data set is successfully received and decoded.

4.7. The check of the In-Vehicle Emergency Call System/Device operability in additional equipment configuration in “Software download” mode

4.7.1. To set the AUTOMATIC_REGISTRATION parameter in TRUE by means of diagnostic software of the In-Vehicle Emergency Call System/Device.

4.7.2. To give a signal “Ignition” on the line enter of vehicles ignition, to make sure that the registration in mobile Network is successfully completed.

4.7.3. Under emulator users interface to send a telematic message to the In-Vehicle Emergency Call System/Device for the enabling software download mode and to make sure by device or emulator users interface indication on downloading.

4.7.4. To imitate the “Emergency call” manually.

4.7.5. To make sure by means of emulator users interface that the minimum data set is successfully received and decoded, and there is an indication of the terminated download of software.

4.7.6. Under emulator users interface to send a telematic message to the In-Vehicle Emergency Call System/Device for the enabling software download mode and to make sure by device or emulator users interface indication on downloading.

4.7.7. To make sure by means of diagnostic software of the In-Vehicle Emergency Call System/Device that the software image was downloaded in operating memory.

4.7.8. To set the parameter SELFTEST_INTERVAL for 2 min. by means of diagnostic software of the In-Vehicle Emergency Call System/Device.

4.7.9. To make sure by means of diagnostic software of the In-Vehicle Emergency Call System/Device, that the period of registration on completing self test POST_TEST_REGISTRATION_TIME is 2 min.

4.7.10. Having wait for at least 2 min. to make sure, that on the party of the operator of system in the interface for viewing of results of reception of data of self-diagnostics there were following changes:

- the self-diagnostics data is successfully accepted;
- the self-diagnostics data is successfully decoded and the result doesn't contain messages on malfunctions of the In-Vehicle Emergency Call System/Device.

4.8. Check of users interface block of the In-Vehicle Emergency Call System/Device in configuration of additional equipment

4.8.1. To enable the external power source of the In-Vehicle Emergency Call System/Device.

4.8.2. To imitate the “Emergency call” manually.

4.8.3. To make sure of dialing and immediate push the “Additional functions” button (before reception of an entering call on the party of the calls processing of centre).

4.8.4. To make sure of the dialing stopped.

4.9. The check of entire memory of In-Vehicle Emergency Call System/Device

4.9.1. To enable the external power source of the In-Vehicle Emergency Call System/Device

4.9.2. By means of the diagnostic software to make sure that the correct number for the SMS transmission ECALL_SMS_FALLBACK_NUMBER is set and the use of GPRS for data transmission is prohibited.

4.9.3. To provide conditions under which implementation by the In-Vehicle Emergency Call System/Device and data transmission by means of use of networks of a mobile radio communication (for example is impossible, to cover antennas of a mobile radio communication with the metal screen).

4.9.4. To push the “Emergency call” button 3 times and to make sure, that there were no changes for viewing of results of reception and decoding of users interface.

4.9.5. To provide the possibility of making calls and data transmission by means of mobile radio communication.

4.9.6. To make sure, that in users interface for viewing of results of reception and decoding data following actions are successfully completed:

- data via SMS are successfully received 3 times;
- minimum data set is successfully decoded 3 times.

4.9.7. By means of diagnostic software to disable data transmission via the in-band modem and SMS and to make sure that in the In-Vehicle Emergency Call System/Device the use of GPRS is prohibited.

4.9.8. By means of diagnostic software set the parameter INT_MEM_TRANSMIT_INTERVAL in 1 min.

4.9.9. Imitate emergency call in automatic mode.

4.9.10. To make sure, that in users interface for viewing of results of reception and decoding data there were no changes.

4.9.11. By means of diagnostic software to enable GPRS for data transmission and wait for 1 min.

4.9.12. By means of emulator users interface to make sure, that following actions are completed successfully:

- data are successfully received via the in-band modem;
- minimum data set decoded.

4.9.13. By means of diagnostic software to disable the possibility of data transmission via SMS and in-band modem and to make sure, that in the In-Vehicle Emergency Call System/Device the use of GPRS is prohibited.

4.9.14. By means of diagnostic software set the parameter INT_MEM_TRANSMIT_ATTEMPTS in 10.

4.9.15. To imitate the emergency call in automatic mode and to make sure, that in users interface for viewing of results of reception and decoding data there were no changes.

4.9.16. By means of diagnostic software to make sure, after 10 failure attempts of sending the minimum data set information on impossibility of data transmission is displayed in the users interface block.

4.10. The check of standby battery work and the power source of the In-Vehicle Emergency Call System/Device.

4.10.1. To enable the external power source of the In-Vehicle Emergency Call System/Device or send the "Ignition" signal to the line enter ignition.

4.10.2. By means of diagnostic software to make sure, that the correct phone number for the transmission SMS ECALL_SMS_FALLBACK_NUMBER is set in the In-Vehicle Emergency Call System/Device and following parameters are set: CALL_AUTO_ANSWER_TIME – 5 min, NAD_DEREGISTRATION_TIME – 5 min.

4.10.3. Making sure that the standby battery is full charged, to disable ignition.

4.10.4. To imitate "Emergency call" manually.

4.10.5. To make sure in establishment of bilateral voice connection with the operator and to establish a maximum level of a sound in the loudspeakers attached to the In-Vehicle Emergency Call System/Device.

4.10.6. Within 5 minutes to say any text.

4.10.7. Terminate the emergency call in emulator users interface.

4.10.8. To leave the In-Vehicle Emergency Call System/Device in a working condition from the reserve battery on 8 h.

4.10.9. In users interface to establish bilateral voice connection to the In-Vehicle Emergency Call System/Device.

4.10.10. Within 5 minutes to say any text.

4.10.11. To give a signal "Ignition" on an entrance of the line of automobile ignition.

4.10.12. If minimum possible level of a battery charge of the battery is reached, the In-Vehicle Emergency Call System/Device has to send the telematic message with information on insufficiency of a charge of the battery and on the block of the user interface the condition "The charge of the standby battery is below the set limit" or a condition "Malfunction";.

4.10.13. If the standby battery is of recharged type, check on compliance to the above requirements has to be carried out after charging of the battery during 24 h. at constant ambient temperature 20°C.

4.11. The check of the In-Vehicle Emergency Call Device Neworl registration

4.11.1. By means of diagnostic software of the In-Vehicle Emergency Call Device to set the parameter AUTOMATIC_REGISTRATION in FALSE and the parameter ECALL_ON in TRUE.

4.11.2. To give a signal "Ignition" on an entrance of the line of automobile ignition and to imitate an emergency call in an automatic mode

4.11.3. By means of emulator users interface to make sure, that following actions are completed successfully:

- data is successfully received via the in-band modem;
- minimum data set is successfully decoded.

-
- 4.11.4. To turn off a signal “Ignition” on an entrance of the line of automobile ignition.
- 4.11.5. By means of diagnostic software of the In-Vehicle Emergency Call Device to set the parameter AUTOMATIC_REGISTRATION in TRUE.
- 4.11.6. To give a signal «Ignition» on an entrance of the line of automobile ignition.
- 4.11.7. To imitate “Emergency call” manually.
- 4.11.8. To terminate the emergency call in emulator users interface and to turn off a signal “Ignition” on an entrance of the line of automobile ignition.
- 4.11.9. By means of diagnostic software to make sure, that the In-Vehicle Emergency Call Device stopped the Network registration by the after the expiration of the period defining a waiting time of a reciprocal call from the operator.
- 4.12. Verification of requirements for current supply and power consumption of the In-Vehicle Emergency Call Device in a configuration of the additional equipment
- 4.12.1. To give the external power source on the In-Vehicle Emergency Call Device or to give a signal «Ignition» on an entrance of the line of automobile ignition.
- 4.12.2. By means of diagnostic software to make sure, that the correct number for data transmission SMS ECALL_SMS_FALLBACK_NUMBER is set in the In-Vehicle Emergency Call Device and following parametres are set: CALL_AUTO_ANSWER_TIME - 5 min, NAD_DEREGISTRATION_TIME - 5 min.
- 4.12.3. Having imitated the “Emergency Call” to make sure that a bilateral vice connection is established and to set maximum sound level in loudspeakers, connected to the In-Vehicle Emergency Call Device.
- 4.12.4. Within 3 miutes to say any text..
- 4.12.5. To make sure, that the power consumption of the In-Vehicle Emergency Call Device is less than 1500 mA at 12 V (1200 mA at 24 V) within 3 min.
- 4.12.6. To terminate “Emergency call” in the emulator users interface and to make sure that the bilateral vice connection is sropped.
- 4.12.7. To turn off a signal “Ignition” on an entrance of the line of automobile ignition of the In-Vehicle Emergency Call Device, to make sure, theat the power consumption is less than 10 mA at 12 V (24 V) within 1 min.
- 4.13. Transmission check on SMS commands at number installation for sending information according via SMS as the reserve channel
- 4.13.1. With the use of the interaction between software of the In-Vehicle Emergency Call Device with the system emulator to initiate transmission of an istallation number command for sending information via SMS, to set 00000001 as the In-Vehicle Emergency Call Device identifier and to set the number for sending the SMS.
- 4.13.2. To make sure of configuration SMS delivery to the In-Vehicle Emergency Call Device.
- 4.13.3. With the use of the system emulator to make sure, that the configuration command is executed by the expiration time of 5 min.
- 4.13.4. To reboot the In-Vehicle Emergency Call Device by a stadard method.
- 4.13.5. Having connected to vehicle system by means of diagnostic software, to make sure, that the corresponding number for SMS transmission is saved in the In-Vehicle Emergency Call Device memory.
- 4.14. The check of the SMS transmission of command for emergency call test number setting.
- 4.14.1. With the use of the interaction between software of the In-Vehicle Emergency Call Device with the system emulator to initiate transmission of test number setting command, to set 00000001 as the In-Vehicle Emergency Call Device identifier.
- 4.14.2. To repeat actions from sec.3.13.2 – 3.13.4.

4.14.3. Having connected to the vehicle system by means of diagnostic software, to make sure, that the corresponding test call number is saved in the In-Vehicle Emergency Call Device memory.

4.15. Transmission check on SMS commands on initialization of a test emergency call.

4.15.1. With the use of system emulator to initiate a command transmission of the test call having specified the MSISDN of SIM-card of the In-Vehicle Emergency Call Device, 00000001 as identifier number of the In-Vehicle Emergency Call Device, in-band modem as means of minimum data set transmission, manual as a type of emergency call.

4.15.2. To make sure of controlling command SMS delivery to the In-Vehicle Emergency Call Device.

4.15.3. With the use of the system emulator to make sure, that the controlling command is executed.

4.15.4. Upon the expiration time of 30 seconds, with the use of system emulator to make sure, minimum data generated in response to request set is successfully delivered and decoded.

4.16. Transmission check according of the minimum data set via SMS with a sign of a test call.

4.16.1. To conduct actions according to sec.3.15.1-3.15.4., having specified as transport of delivery of the emergency call the SMS channel.

4.17. Check of transmission of the minimum data set by means of the in-band modem with a sign of a test call.

4.17.1. By means of diagnostic software to make sure, that the correct test call number is set in parameters.

4.17.2. By means of system emulator to initiate test mode.

4.17.4. Upon the expiration time of 20 sec. to make sure, by means of emulator users guide, that a controlling command is completed, the minimum generated for request data set is received and correctly decoded.

4.18. Transmission check of SMS commands on repeated transmission of the minimum data set of the event of a road accident recorded in the past.

4.18.1. By means of system emulator to initiate repeated transmission of the minimum data set with the specified MSISDN of SIM-card of the In-Vehicle Emergency Call System/Device, 00000001 as identification number of the In-Vehicle Emergency Call Device, SMS as a transport delivery, and identification sequence number of emergency call message, the last is requested for minimum data set

4.18.2. To make sure that controlling command SMS is delivered to the In-Vehicle Emergency Call Device.

4.18.3. To make sure by means of system emulator that the command is completed.

4.18.4. Upon the expiration time of 30 seconds by means of emulator interface, to make sure that the minimum data set generated upon request is delivered and correctly decoded.

4.19. Transmission check in a mode of packet transmission of specified in-vehicle software data of the In-Vehicle Emergency Call Device in a configuration of the additional equipment.

4.19.1. With use of system emulator to initiate a packet transmission of command data to the In-Vehicle Emergency Call Device of the specific software image file, to set 00000001 as the In-Vehicle Emergency Call Device identifier and to set a full path to the specific image file of software.

4.19.2. To make sure by means of users interface, that the software image file is downloaded to the In-Vehicle Emergency Call Device.

4.19.3. To reboot the In-Vehicle Emergency Call Device by a standard method.

4.19.4. To make sure, by means of diagnostic software, that the In-Vehicle Emergency Call Device operational software version number coincides with the number of software provided by the manufacturer.

4.20. The check of the “Emergency call” button protection from accidental pressing and its illumination

4.20.1. To conduct external inspection of the In-Vehicle Emergency Call Device interface block and to make sure that the “Emergency call” button has mechanical protection from accidental pressing.

4.20.2. The technical realisation of methods of the “Emergency call” button mechanical protection from accidental pressing is determined by the manufacturer.

4.20.3. To make sure, that the In-Vehicle Emergency Call Device users guide contains the “Emergency call” button activation instructions.

4.20.4. To give a signal “Ignition” on an entrance of the line of automobile ignition

4.20.5. To conduct external inspection of the In-Vehicle Emergency Call Device interface block and to make sure that the “Emergency call” button illuminated.]

Test methods for EMC requirements for e-call devices

1. Definitions

1.1 “*conductive man-made noise*” - electromagnetic interference, the energy which is transmitted through one or more conductors

1.2 “*Road Accident Emergency Response System*” - automated navigation and information system, which operates using the signals of the global navigation satellite system, which implements the delivery of messages about the road accidents and other emergencies on the motor roads to the emergency services.

1.3. “*tests rigidity degree (for noise immunity)*” conventional number set by the normative documents for testing the equipment for noise immunity reflecting the intensity of the test object exposure to noise with the parameters regulated for each rigidity degree.

1.4 The following symbols and abbreviations are used:

PC - personal computer;;

CAN- Controller Area Network (industrial network standard focused on the networking of the various execution units and sensors, including the automobile automatics;

USB - Universal Serial Bus (universal serial wire bus)

2. General principles

2.1 The test object is the In-Vehicle Emergency Call System.

The number of the in-vehicle emergency call system/device test samples shall be at least 3 pcs. Each of the in-vehicle emergency call system/device samples submitted for testing is subject to tests (inspections).

2 Test conditions

2.2 the in-vehicle emergency call system/device tests for electromagnetic compatibility are carried out in normal climatic conditions:

- ambient air temperature – $(25 \pm 10)^{\circ}\text{C}$;
- relative air humidity – from 45% to 80 %;
- bar pressure – from 84.0 to 106.7 kPa (from 630 to 800 mm Hg).

The the in-vehicle emergency call system/device maintenance is not carried out during testing.

2.3 Safety requirements for testing

When measuring the in-vehicle emergency call system/device parameters during testing, the safety requirements set out the operational documents for the measuring instruments and testing equipment used in testing shall be met.

Turning on the measuring instruments and test equipment shall only be carried out with an external ground connected to them. Connecting the protective grounding terminals to the ground loop shall be conducted before other connections, and their disconnecting – after all other disconnections.

Connecting and disconnecting of cables, devices and measuring instruments to the test the in-vehicle emergency call system/device may only be carried out with the turned off supply voltage of all the devices that are part of the test set, and with the test system disconnected from the power supply circuits.

2.4 The test equipment used for testing must be metrological certified.

The measuring instruments used in the test must have an approved type and be verified at the moment of testing.

2.5 The in-vehicle emergency call system/device operability check during the tests should be carried out using a special diagnostic programme (hereinafter – the in-vehicle emergency call system/device test programme).

2.5.1 The testing programme is developed by the in-vehicle emergency call system/device manufacturer and is supplied upon a separate request.

2.5.2 The in-vehicle emergency call system/device testing programme should have the following functionalities:

- possibility to choose the diagnostic tests by the user;
- possibility to conduct the tests (test sequences, tests starting and stopping, setting the in-vehicle emergency call system/device diagnosing parameters, etc.) in manual and automatic modes;
- possibility to determine the number of automatic testing cycles from 1 to 10,000;
- to display the test results in a short form (all tests are successful, an error is detected when testing) on a computer screen and to a text file (the text file format is specified by the in-vehicle emergency call system/device manufacturer)
- to display the test results in a detailed form (the test result and additional information determined by the in-vehicle emergency call system/device manufacturer for each completed test) on a computer screen and to a text file (the text file format is specified by the in-vehicle emergency call system/device manufacturer)

to transmit the test results through the use of mobile communication networks

- to ensure the availability of information about the hardware platform versions and the software for all the in-vehicle emergency call system/device components, including the versions of hardware platforms and the software for the GNSS receiver, GSM/UMTS modem, tone modem, control processor;
- to provide the possibility to read and clear the contents of the in-vehicle emergency call system/device internal memory;
- to provide the possibility to read and set the in-vehicle emergency call system/device setting parameters;
- to ensure the possibility to update the software of all the in-vehicle emergency call system/device components.

2.5.3 If to ensure the testing program work with the test the in-vehicle emergency call system/device any electrical signal converters (for example, USB-CAN signal converter) are required, these converters must be supplied by the in-vehicle emergency call system/device manufacturer complete with the testing programme.

2.6 Completeness of the in-vehicle emergency call system/device submitted for testing installed in the standard equipment configuration (on the line of the vehicle manufacturer) is determined by the vehicle manufacturer.

Completeness of the in-vehicle emergency call system/device installed in the additional equipment configuration (in the service/installation centers or on the vehicle manufacturer dealer's site after the release/production of the vehicle) is determined by the system manufacturer.

2.7 Reporting on the tests results

The in-vehicle emergency call system/device test (verification) results are reflected in the protocol of tests and measurements indicating:

- name of test laboratory (center), location, phone, fax and e-mail;
- identification parameters of the test sample;
- test conditions;
- information on the test and measurements methodology according to this standard;
- the used test (measurement) equipment and measuring instruments;

- list of sections (clauses and sub clauses) of regulations which contain the requirements compliance with which is established and the results of conformity assessment for each individual requirement;
- certificate of the test sample compliance with the established requirements;
- position, name and signature of the person conducted the tests and measurements;
- position, name and signature of the testing laboratory (center) head, sealed by the test laboratory (center);
- date of tests and measurements, date of registration and registration number of the protocol.

3. Test Methods

3.1 Test Volume

3.1.1 The list and sequence of the in-vehicle emergency call system/device compliance tests (checks) for electromagnetic compatibility requirements are specified in Table 1.

Table 1. The list and sequence of the in-vehicle emergency call system/device compliance tests (checks) for electromagnetic compatibility requirements

Test (check) name	Number of paragraph from subsection 3.2 of this standard (Figure, diagrams)
Operational documentation completeness check	3.2.1
In-vehicle Emergency Call System/Device completeness check	3.2.2
The in-vehicle emergency call system/device operability check at the nominal supply voltage	3.2.3 (Figure A.2)
The in-vehicle emergency call system/device operability check at minimum and maximum supply voltage	3.2.4 (Figure A.2)
The in-vehicle emergency call system/device operability check when exposed to the reverse polarity supply voltage	3.2.5 (Figure A.2)
Check of the in-vehicle emergency call system/device external electric circuits ensured protection from a short circuit on the supply voltage source poles	3.2.6, (Figure A.2)
Check of the in-vehicle emergency call system/device resistance under the impact of conductive noise on supply circuits	3.2.7, (Figure A.3)
Check of the emission degree into the onboard network of the vehicle's own noise generated by the in-vehicle emergency call system/device	3.2.8, (Figure A.4)
Check of the in-vehicle emergency call system/device noise immunity in the control and signal circuits	3.2.9, (Figure A.3)
Check of the in-vehicle emergency call system/device immunity to noise from electrostatic discharge	3.2.10, (Figure A.2)
Requirements compliance check for the radio noise voltage on the in-vehicle emergency call system/device power supply connectors	3.2.11, (Figure A.5)
Requirements compliance check for the intensity of the electromagnetic field generated by the in-vehicle emergency call system/device	3.2.12, (Figure A.5)
Check of the in-vehicle emergency call system/device resistance to electromagnetic emission	3.2.13, (Figure A.6)

3.1.2 Testing and auxiliary equipment, and measuring instruments listed in table 2 are used for the tests.

Table 2. Testing and auxiliary equipment

Equipment name	The required technical characteristics of the devices and equipment
Impulse noise test generator in the vehicle onboard network	Conductive noise impulse generation according to ISO 7637
Onboard network equivalent	According to ISO 7637
Connecting clamp (capacitive clamp)	Connection capacity – (150 ±50) pF; Beam diameter – (4-40) mm; Voltage magnitude for insulation strength – at least 200 V; Impedance of coax connection – (50 ± 10%) Om
Oscillograph	Band up to 100 MHz Inaccuracy 3 %
Power source	Output voltage from 0 to 30 V, Maximum load current 10 A
PC	External interface – USB 2.0; OS – Windows 2000/XP
Interface block	Test work place connection
System for checking the technical equipment for the immunity to noise from electrostatic discharge	Electrostatic discharge voltage range (0–15) kV
System for checking the technical equipment for the resistance to electromagnetic emission	Frequency range (20–2000) MHz
System for measuring the electromagnetic field of the man-made radio noise emission	Frequency range (0.009–1000) MHz

3.2 Test procedure.

3.2.1 Operational documentation completeness check

To check the OD completeness supplied with the in-vehicle emergency call system/device it is necessary to make sure that the submitted test documentation meets the requirements

3.2.1.1 the in-vehicle emergency call system/device operational documentation in configuration of additional equipment shall include:

- Installation Guide;
- Setup and test guide;
- the in-vehicle emergency call system/device user guide;
- Short brochure on the in-vehicle emergency call system/device use;
- the in-vehicle emergency call system/device passport.

3.2.1.2 The the in-vehicle emergency call system/device user guide and the short brochure for the in-vehicle emergency call system/device in additional configuration, shall include a pictogram of green or black colour. The figure of pictogram is given below.



The the in-vehicle emergency call system/device installed in the standard equipment configuration is considered as having passed the test if the composition of the set of documents submitted to the test conforms to the one set by the vehicle manufacturer.

3.2.2 the in-vehicle emergency call system/device completeness check

the in-vehicle emergency call system/device completeness check is carried out by means of comparison with the complete set established in this subsection.

3.2.2.1 The the in-vehicle emergency call system/device installed in the additional equipment configuration shall include following components:

- The the in-vehicle emergency call system/device and fastening mechanism (mechanisms) of the in-vehicle emergency call system/device;
- User interface block of the in-vehicle emergency call system/device and fastening mechanism (mechanisms) of the User interface block;
- The the in-vehicle emergency call system/device and User interface block connection cable;
- The acceleration sensor with the connection cable and fastening mechanism (mechanisms) of the acceleration sensor (in case of external acceleration sensor) – only for vehicles of category M1

N o t e – In case if an airbags control block is not used for the road accident detection.

- Microphone (microphone set) with a connection cable and fastening mechanism (mechanisms) for the microphone (microphone set);
- Connection cable (cables) for the in-vehicle emergency call system/device and vehicle electronic system (adapter for the specified vehicle);
- Standby battery;
- Optional – a speaker phone, fastening mechanism (mechanisms) for the speaker phone and the connection cable.

Any comlectation of the in-vehicle emergency call system/device components in one block (for example, the main block and an additional loudspeaker composed in one box) is allowed.

3.2.2.2 The “Emergency call” button shall contain a red pictogram. The figure of pictogram is given below.

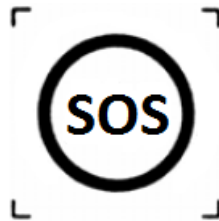

The “Additional function” button shall contain a blue pictogram. The figure of pictogram is given below.



The In-Vehicle System installed in the standard equipment configuration is considered as having passed the test if the in-vehicle emergency call system/device delivery complete set meets the requirements set by the vehicle manufacturer.

3.2.3 the in-vehicle emergency call system/device operability check at nominal supply voltage

3.2.3.1 To check the in-vehicle emergency call system/device operability it is necessary to prepare the check workplace using the connection diagram indicated in Figure A.1 (Appendix A):

- to install on the PC a testing program (see 2.5) to check the in-vehicle emergency call system/device operability (if it has not been done before);

- to set for the power source the output voltage G1 (12.0 + 0.1) V or (24.0 + 0.1) C - depending on the on the vehicle power supply system;

to connect to the in-vehicle emergency call system/device the necessary devices according to the connection diagrams shown in figures A.2 – A.6 depending on the conducted tests. All connected devices shall be turned off;

- to turn on the PC and wait until the operational system downloads;

- to run the test program on the PC;

- to turn on the power source G1 and the power of the connected devices, and the status indicators in the main dialog box of the test program should inform about the interaction of the coupling unit and the connected the in-vehicle emergency call system/device sample with the PC. In the case of an error indication it is necessary to turn off the power sources, to check the correctness of the devices connection.

3.2.3.2 the in-vehicle emergency call system/device operability check consists in the automated sequential execution of the tests that are selected in the main dialog box of the testing program.

To perform the check it is necessary to:

- on the tab "Tests" of the testing program to choose the execution of all the tests (for example, to click on "Select All");

- to make sure that the "To execute cyclically" mode is turned off;

- to press the start button of the selected tests "Start";

- to control the automated tests implementation.

3.2.3.3 The tested the in-vehicle emergency call system/device is considered as having passed the test if during the check performance the test program does not give the testing errors messages.

3.2.4 the in-vehicle emergency call system/device operability check when changing the supply voltage (minimum and maximum supply voltage)

3.2.4.1 To prepare test working place according to the requirements of 3.2.3.1, using the connection diagram shown in Figure A.2 Annex 2.

3.2.4.2 For the power source G1 to set the nominal voltage. To perform testing in accordance with 3.2.3.2.

3.2.4.3 To set the minimum output voltage of the power source. To perform testing in accordance with 3.2.3.2.

3.2.4.4 To set the maximum output voltage of the power source. To perform testing in accordance with 3.2.3.2.

3.2.4.5 The tested the in-vehicle emergency call system/device is considered as having passed the test if when performing the checks in accordance with 3.2.3.2 and 3.2.3.3 the operability checks are completed successfully.

3.2.5 the in-vehicle emergency call system/device operability check after the exposure to the reverse polarity supply voltage

3.2.5.1 To check the in-vehicle emergency call system/device operability after the exposure to the reverse polarity supply voltage, it is necessary to prepare test working place according to 3.2.3.1, using the connection diagrams shown in figure A.2.

3.2.5.2 To turn off the power source G1.

3.2.5.3 To disconnect the cables 2 and 3 from the power source.

3.2.5.4 To connect the terminal marked "+" of cable 1 to the negative terminal of the power source G1, the terminal "-" of cable 1 – to the positive terminal of the power source G1. 3.2.5.5 To turn on the power source G1 for at least 5 minutes.

3.2.5.6 To turn off the power source G1.

3.2.5.7 To conduct the in-vehicle emergency call system/device check according to 3.2.1 using the diagram of Figure 1.

3.2.5.8 The tested the in-vehicle emergency call system/device is considered as having passed the test if after the exposure to the reverse polarity supply voltage the operability checks are carried out successfully.

3.2.6 Check of the in-vehicle emergency call system/device external electric circuits ensured protection from a short circuit on the supply voltage source poles

3.2.6.1 To prepare the stand according to 3.2.3.1.

3.2.6.2 To disconnect the X1 connector of cable 1 from the module A.2 (see Figure A.2). (Annex A).

3.2.6.3 With a jumper or using any other appropriate way to provide an alternate short-term (up to 3 s) closure of each X1 connector contact of cable 1 to contacts "+" and "-" of the DC source A3.

3.2.6.4 With a jumper or using any other appropriate way to provide an alternate short-term (up to 3 s) closure of the contacts 1-7 X1 of the «ДІАТ» connector to the poles "+" and "-" of the DC source A3.

3.2.6.5 To connect the X1 connector of cable 1 to the module A.2 and to perform the in-vehicle emergency call system/device operability check.

3.2.6.6 The tested the in-vehicle emergency call system/device is considered as having passed the test if, after the alternate closure of each contact of the in-vehicle emergency call system/device connectors on the power source poles, the in-vehicle emergency call system/device operability check was conducted successfully.

3.2.7 Check of the in-vehicle emergency call system/device resistance under the impact of conductive noise on supply circuits

3.2.7.1 Check of the in-vehicle emergency call system/device immunity to conductive noise in the onboard network is conducted under the method set out in ISO 7637.

3.2.7.2 Compliance is checked using the impulse noise test generator in the onboard network

Note – To check the in-vehicle emergency call system/device immunity to conductive noise in the onboard network other type of equipment, ensuring the generation of test impulses 1, 2, 2a, 3a, 3b, 4, 5, 6, 7 can be used in accordance with ISO 7637

3.2.7.3 To prepare test working place according to clause 3.2.3.1, using the diagram in Figure A.3.

3.2.7.4 To expose the in-vehicle emergency call system/device to the test impulses impact.

3.2.7.5 The number of impulses and the tests duration shall be the following:

- for each test impulse 1 and 2 – not less than 5000 impulses., the interval between the impulses – 0.5 s;
- for each test impulse 3a and 3b – not less than 1 hour; the interval between the impulses – 0.1 s;
- for each test impulse 4, 5, 6, 7 – not less than one impulse; the interval between the impulses – 1 min.

3.2.7.6 The test impulses parameters must meet the rigidity degree according to ISO 7637 for onboard networks 12 (24) V.

3.2.7.7 During the test impulses impact it is necessary to check the in-vehicle emergency call system/device operability periodically as specified in clause 3.2.3.2.

3.2.7.8 During and after the test impulses impact the "Report" box of the testing program shall not display the error messages, which corresponds to a functional class A according to ISO 7637.

3.2.7.9 The the in-vehicle emergency call system/device test sample is considered as having passed the test if it meets the requirements of ISO 7637 on the in-vehicle emergency call system/device rigidity degree of a functional class A under the impact of the test impulses 1, 2, 2a, 3a, 3b, 4, 5, 6, 7.

3.2.8 Check of the emission degree into the onboard network of the in-vehicle emergency call system/device own noise

3.2.8.1 Check of the in-vehicle emergency call system/device own noise emission into the vehicle onboard network is conducted according to the method set out in ISO 7637.

3.2.8.2 To prepare test working place according to 3.2.3.1, using the diagram of Figure A4.

3.2.8.3 During the in-vehicle emergency call system/device check according to 3.2.3.2 to control with the oscilloscope the voltage of noise generated by the in-vehicle emergency call system/device in the onboard network. The noise voltage levels of all kinds according to ISO 7637, generated by the in-vehicle emergency call system/device for on-board networks with a voltage of 12 (24) V shall not exceed the following values:

- peak noise voltage value of the type 1 – minus 15 (35) V;
- peak noise voltage value of the type 2 – 15(15) V;
- peak noise voltage value of the type 3 – from minus 15(25) to 15(25) V.

The specified noise voltage values corresponds to the I emission degree according to ISO 7637.

3.2.8.4 The tested the in-vehicle emergency call system/device sample is considered as having passed the test if the noise voltage levels of all kinds generated by the in-vehicle emergency call system/device do not exceed the values specified in 3.2.8.3.

3.2.9 Check of the in-vehicle emergency call system/device noise immunity in the control and signal circuits

Compliance is checked using the impulse noise test generator in the onboard network.

Note – To check the in-vehicle emergency call system/device immunity to noise in the control and signal circuits other type of equipment, ensuring the generation of test impulses can be used in accordance with ISO 7637.

To prepare test working place according to 3.2.3.1 using the diagram of Figure A3.

(Annex A).

To connect the impulse noise generator to the connecting clamp (capacitive clamp).

To place the harnesses connecting the in-vehicle emergency call system/device with the debugging and control stand and the discrete inputs into connecting clamp (capacitive clamp). At the end of the harness with discrete inputs to connect the load or its equivalent.

To expose the in-vehicle emergency call system/device to the impact of the test impulses 1, 2, 3a, 3b.

The test impulses parameters must meet the in-vehicle emergency call system/device rigidity degree according to ISO 7637 for onboard networks 12 (24) V.

During the test impulses impact it is necessary to check the in-vehicle emergency call system/device operability periodically as specified in 3.2.3.2.

During the impact of all test impulses the "Report" box of the testing program shall not display the error messages, which corresponds to a functional class A and the rigidity degree requirements according to ISO 7637.

The tested the in-vehicle emergency call system/device sample is considered as having passed the test if it meets the requirements of 3.2.3.2.

3.2.10 Check of the in-vehicle emergency call system/device immunity to noise from electrostatic discharge

3.2.10.1 Check of the immunity to noise from electrostatic discharge is conducted under the method set out in ISO 10605:2008.

3.2.10.2 Compliance is checked using the electrostatic discharge test generator with the parameters according to ISO 10605:2008.

3.2.10.3 The tested the in-vehicle emergency call system/device sample shall be resistant to the test impulses from electrostatic discharge of the in-vehicle emergency call system/device rigidity degree with the following values of the test voltage:

- contact discharge - ± 4 ; ± 6 ; ± 7 kV;

air discharge - ± 4 ; ± 8 ; ± 14 ; ± 15 kV.

3.2.10.4 The minimum number of discharges for each voltage – 3, the minimum time interval between discharges – 5 s.

3.2.10.5 To test the in-vehicle emergency call system/device it is necessary to put the in-vehicle emergency call system/device into the center of the ground plane. Check shall be carried out with the use of an insulating base, on which the tested the in-vehicle emergency call system/device sample is placed.

3.2.10.6 To prepare test working place according to 3.2.3.1 using the connection diagram in Figure A.2.

3.2.10.7 To set the attribute "To execute cyclically" in the testing programme.

3.2.10.8 To press the start button of the selected tests "Start" (and the button name is changed into "Stop").

3.2.10.9 To check the in-vehicle emergency call system/device immunity to contact discharge in the following way:

- to introduce the test generator discharge tip into a direct contact with the in-vehicle emergency call system/device body;

- each discharge point (three arbitrary points in different parts of the in-vehicle emergency call system/device body are selected) should be tested at all voltage levels specified in 3.2.10.3 for contact discharge.

3.2.10.10 To check the in-vehicle emergency call system/device immunity to air discharge in the following way:

- to place the discharge tip perpendicular (tolerance $\pm 15^\circ$) to the discharge segment;

- to move the discharge tip slowly (at a speed of 5 mm/s) in the direction of the in-vehicle emergency call system/device discharge point until the first discharge appears;

each discharge point shall be tested at all voltage levels specified in 3.2.9.3 for air discharge.

Note - If there is no discharge, it is necessary to continue moving the discharge to the contact with the discharge point. If there is no discharge in this case too, it is necessary to stop checking at these levels for a given location of the tip.

3.2.10.11 The tested the in-vehicle emergency call system/device sample is considered as having passed the test if after the exposure to the test discharges the operability checks according to 3.2.3.2 are carried out successfully.

3.2.11 Requirements compliance check for the radio noise voltage generated by the in-vehicle emergency call system/device

3.2.11.1 To prepare test working place according to 3.2.3.1 using the connection diagram in Figure A.5 Annex A.

3.2.11.2 The following measurement equipment is for the test:

Radio-noise meter:

- The nominal width of radio-noise meter band (at minus 6 Db) shall be:
- 0,2 kHz in frequency range from 0,009 to 0,15 MHz;
- 9 kHz in frequency range from 0,15 to 30 MHz;
- 120 kHz in frequency range from 30 to 1000 MHz;

It is necessary to use the A3 network equivalent of type 5

3.2.11.3 Test working place should be located in a shielded room

It is necessary to use the A3 network equivalent of type 5 for providing specified modes.

It is necessary to measure noise field density during the assessment of noise level by means of network equivalent.

During radio-noise measurement the network equivalent shall be located at the distance of 0,8 km from the tested device.

Radio noise voltage is measured in the frequency range (0.009–100) MHz only at clap circuits of the in-vehicle emergency call system/device

The change from one control measure frequency to another is provided by means of gradual tuning of radio-noise meter. Radio-noise and frequency is registered in case of maximum level increase in regard to the previous control frequency.

During the radio devices test the frequency of measure shall not coincide with base, out-of-band and extraneous emissions of radio device.

If data of radio-noise meter changes during the measurement procedure then the most frequently seen value for at least 15 sec. shall be used.

In a frequency range from 0,009 to 0,15 MHz the horizontal product of magnetic field shall be measured.

3.2.11.4 In case if less than for samples are provided for the test the requirements for radio-noise density are considered to be conformed, if the value of each device is for 3 Db less than the norm.

Quasi-peak values of unsymmetrical radio-noise density U in decibels in relation to 1mkV shall not exceed values given in Figure 1 or calculated by formulas:

For graph 1:

$$U = 80 - 28,9 \lg f / 0,01$$

For graph 2:

$$U = 90 - 28,9 \lg f / 0,01$$

Quasi-peak values of radio-noise density E in decibels in relation to 1mkV shall not exceed values given in graph 1 in Figure 2 or calculated by formulas:

$$E = 60 - 20,4 \lg f / 0,01$$

f – frequency, MHz

The tested sample is considered to have passed the test if radio-noise density of the in-vehicle emergency call system/device does not exceed the norms specified in par. 3.2.11.4

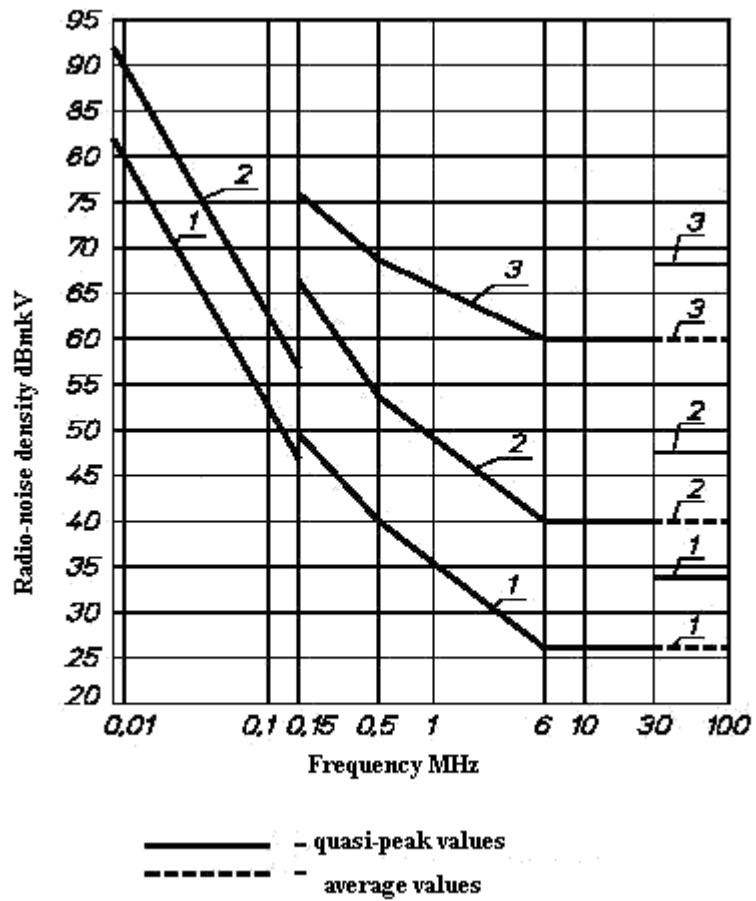

Figure 1. Radio-noise density norms

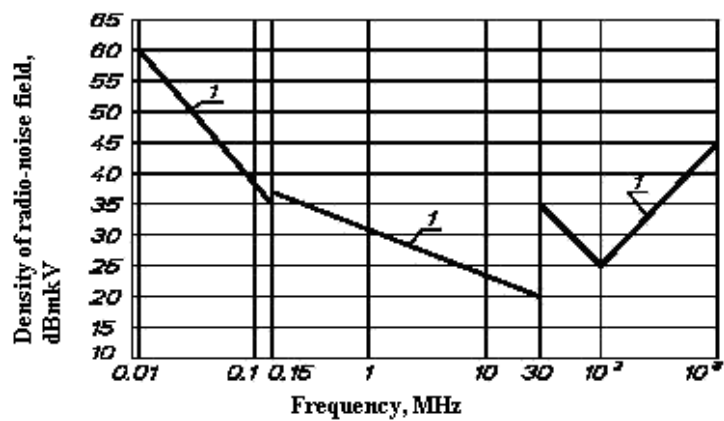

Figure 2. Norms for radio-noise density field

3.2.12 Requirements compliance check for the intensity of the electromagnetic field generated by the in-vehicle emergency call system/device

Intensity of the electromagnetic field generated by the in-vehicle emergency call system/device is measured in the frequency range (30-1000) MHz according to UN ECE Regulations №10 (subsections 6.5, 6.7).

To prepare test working place according to 5.2.3.1 using the connection diagram in Figure A.5 Annex A. In this case test working place should be located in an anechoic shielded room or on an open certified site, and the location of the devices and equipment shall be as recommended in UN ECE Regulations №10

In the measurements it is necessary to use the A3 network equivalent of type 5

The tested the in-vehicle emergency call system/device sample is considered as having passed the test if the intensity level of the electromagnetic field generated by the in-vehicle emergency call system/device does not exceed the standards set in UN ECE Regulations №10 for broadband and narrowband noise from electrical / electronic sub-assemblies.

3.2.13 Check of the in-vehicle emergency call system/device resistance to electromagnetic emission

3.2.13.1 The test is performed in accordance with one of the selected test methods in accordance with UN ECE Regulations №10 (6.7 and Appendix 9)].

3.2.13.2 To prepare test working place according to 3.2.3.1 using the connection diagrams in Figure A.5 Annex A and to check the in-vehicle emergency call system/device operability according to 3.2.3.2. and the selected test method according to UN ECE Regulations №10.

3.2.13.3 To turn on the mode "To execute cyclically" on the tab "Tests" of the testing programme.

3.2.13.4 To press the start button of the selected tests "Start".

3.2.13.5 To expose the in-vehicle emergency call system/device to electromagnetic emission when it is turned on changing the emission frequency in the direction from the lower frequency of 20 MHz to the upper of 2000 MHz.

To account for the time of the in-vehicle emergency call system/device response on the influencing factor, duration of test at each discrete frequency should be at least 2 seconds.

3.2.13.6 The tested the in-vehicle emergency call system/device sample is considered as having passed the test if during the tests according to 3.2.13.5 all tests were performed without errors.]

[Annex 13

**Test methods for e-call devices for determination of the
accident moment]**

Annex 14

Minimum Set of Data

The MSD shall be represented in Abstract Syntax Notation (ASN.1) using the Unaligned Packed Encoding Rules (UPER) as defined in ISO/IEC 8825-2 using the ASN1 definitions defined below.

Table 14.1. Contents/format of the MSD data concept

ASN.1 PER representation of MSD

Table 14.2. Contents/format of the optional additional data block for Russia

ASN.1 PER representation of the optional additional data block for Russia (oid = "1.4.1")

~~Annex XXX1~~

~~Mobile telephone communication networks~~

~~This annex contains the list of mobile telephone communication networks to be used for approval test in accordance with paragraph 6.6.1., 15.1.3., 15.2.3.2. and 24.2.2.~~

~~GSM 900,~~

~~GSM 1800,~~

~~UMTS 900 and~~

~~UMTS 2000~~

~~XXXXX~~

The AECD shall be capable of communication on mobile telephone communication networks using the standards described in clause 6.6.

[Annex XXX2

Public-safety answering points

This annex contains the list of public-safety answering points to be used for approval test in accordance with paragraph 6.6.3. and 24.2.2.

XXX

XXX]

Justifications and comments:

Title of the regulation: the kick-off meeting agreed to structure the draft regulation in three parts, taking the UN Regulation No.58 (rear underrun protection) as an example. In this regard, it is deemed logical that the E-call devices are called AECD (Accident Emergency Call Devices) and the integrated systems AECS (Accident emergency Call System).

Paragraph 1 (Scope): the kick-off meeting agreed limiting the scope to the vehicles of categories M1 and N1 as a 1st step. It is also reasonable to align the scope on the that of UN R94 and UN R95 as an AECS regulation is a “post-crash” regulation. In addition, the regulation should also be open to Contracting Parties not signatories to UN R94 and 95 and therefore there should not be any reference to these regulations.

Part III should cover the vehicles equipped with an AECD not approved to the regulation and the vehicles which have a fully intergrated AECS.

The proposed wording in addition opens the possibility for the manufacturers to request approval for vehicles not covered by the proposed scope, intended for countries which would mandate AECD/AECS for vehicles outside the scope of this regulation.

Paragraph 1.(c): OICA suggests indicating in the scope of the regulation to which vehicle categories the regulation applies. This clarifies and simplifies the text of the regulation as it permits to avoid referring to paragraphs 15.2. to 15.2.2. proposed by the Russian Federation. The text proposed by OICA is inspired from UN R94 and R95.

Paragraph 2.1.: definition of E-call device. The AECS informal group Secretary wonders whether limiting the definition to a general wording such as “... means an electronic safety system whereby national emergency services are automatically notified when a vehicle is involved in a severe road accident.”

OICA believes that the definition of the device must be restricted to in-board system, which is unable to influence the network environment, because at the time of Type Approval, only the generation of a signal can be demonstrated and assessed. In addition, OICA believes that there is no necessity that the AECS utilizes two GPS networks because existing AECS are operational with one GPS network only. It may indeed happen also that only one GPS network is available at the time of the accident.

Paragraph 2.2.: OICA finds the definitions of the components too design restrictive because a list would limit the development of new technologies. In addition, such list would force the vehicle manufacturer to apply for an extension of approval each time a small change to the device appears (e.g. change of storage from 256mb to 512mb).

Paragraph 2.3.: OICA wonders whether such definition is appropriate for this regulation. For the purpose of e-call, an accident is the event which simply provokes the emission of the e-call triggering signal. OICA suggests simply deleting this definition or creating a more technical definition.

Paragraph 2.4.: OICA suggests deleting the data which are not included in the MSD (minimum set of data) of the existing regulations because the UN regulation should be compatible with ERA-GLONASS (GOST 54620 does not include vehicle speed in its MSD table) and the AECS in current production should remain accepted. OICA suggests referring to the existing definition in the EN Standard: EN 15722:2011 (Intelligent transport systems – eSafety – eCall minimum set of data).

Paragraph 2.5.: the state of art communication modules are designed for both voice communication and data transmission, and use terrestrial mobile telephone networks.

Paragraph 2.6.: This entry is not used in the draft text. In addition, the wording proposed by OICA for paragraph 2.5. covers the voice modem definition

Paragraph 2.7.: the user interface could be a simple function. In addition, this item could well be already covered by paragraph 2.8.

Paragraph 2.9.: the manner of attachment should not be part of a component approval, rather part of the installation approval.

Paragraph 2.10: Such new definition for vehicle type is necessary for the approvals according to Parts II and III of the regulation.

Paragraph 2.11.: editorial changes

Paragraph 2.12.: proposal for a definition of “PSAP”

Paragraphs 4.1. and 4.2.: OICA believes that the markings should not be always visible to the final user. In addition, the front face of the AECD interface unit could be shared with other equipment, making it difficult to make the brand marking visible. The visibility of such marking provides no safety benefit.

Paragraph 6: the common wording in UN regulations is “requirements”.

Paragraph 6.1.: OICA proposes a wording inspired from UN R116 (anti-theft devices). The informal group may decide to transfer paragraph 6.1.2. into Parts II and III of the regulation.

Paragraphs 6.2. and 6.3.: editorial improvements

Paragraph 6.4.: OICA recommends not adding unnecessary cross-references in the regulation as not all Contracting Parties may be signatories to both regulations (the AECS regulation and the referred regulation).

Paragraph 6.5.: editorial improvements. OICA in addition points out that the draft text of annex 9 currently only refers to the GLONASS system; OICA is keen that the UN regulation is technology neutral and may be applicable to countries where the GLONASS system is not present. Finally, OICA is keen that the regulation is limited to the AECD/AECS, and does not extend to the testing of the GPS itself.

Paragraph 6.6.: OICA is of the opinion that the mobile communication networks should not be specified in the core of the UN regulation because it depends on the infrastructure of the Contracting Party applying the regulation, while the UN regulation should focus on the in-board equipment. In order to ensure that AECD and AECS fulfil the requirements relevant to the GSM networks, OICA proposes to add an annex in which each Contracting Party newly signatory to the regulation could add the specifications of the GSM networks established in its territory. For obtaining an approval to this regulation, the applicant should then have to demonstrate compatibility of its product to the GSM network specifications referred to in this additional annex.

Paragraph 6.6.1.: OICA finds the reference to a SIM card too much linked to the current technology.

Paragraph 6.6.2.: OICA questions the relevancy of such provision in an approval regulation as the data exchange profiles may change according to the Contracting Parties. The final wording must be re-assessed when the Annex 10 is finalized. OICA in addition questions the wording “establish mandatory priority flagging for emergency calls”.

Paragraph 6.6.3.: OICA finds unnecessary mandating full duplex voice connection, as it may prevent systems of a different level of complexity, yet providing proper performance. OICA suggests providing “if fitted” requirements for duplex voice connection. In addition, OICA challenges the reference to existing GSM standards as they may evolve. The provisions of Annex XXX2 should be discussed within the informal group.

Paragraph 6.6.4.: OICA proposes an editorial improvement. In addition, OICA questions the proposal for a second attempt of voice and text communication: the network will not improve after the voice communication failed, and the current EU E-call program does not include SMS communication.. OICA also questions the necessity of an “energy-independent memory”.

Paragraph 6.6.5.1: OICA finds this paragraph not harmonized with the EU e-call system (SMS communication), and not necessary for an AECD (component approval).

Paragraph 6.7.: OICA recommends editorial improvement inspired from UN R131 (AEBS). In addition, OICA finds it unnecessary to mandate capability of selfcheck results by GSM.

Paragraph 6.8.: Annex 11 needs in-depth consideration.

Paragraph 6.9.: OICA is of the opinion that a 20 minutes call-back mode communication is sufficient (consistency with paragraph 6.6.5.2. and performance requirement of 10 minutes voice communication on back-up battery energy needs to be re-visited because it generates strong technical difficulties and may be design-restrictive in certain cases. Battery lifetime requirement is design-restrictive: the source of power should remain at the choice of the manufacturer; the regulation should only provide performance requirements.

Paragraph 6.10.: OICA believes this requirement unnecessary and thinks that it could prevent some systems which can provide safety improvement without this feature. Yet the device may also need to be able to communicate with other systems for testing and homologation issues. OICA suggests deleting paragraph 6.10.

Paragraph 7: OICA suggests using the wording recommended per the document GRSG/2013/8 (adopted at the 104th session of GRSG).

Paragraph 12.1.: OICA finds the definition of AECS not necessary in the Part II of the regulation, and proposes to put a definition in Part III of the regulation.

Paragraph 12.2.: it may be opportune to simply define the reception of the triggering signal as the time of the accident. This triggering signal is emitted by a CPU or directly by the acceleration sensors, according to the design of the vehicle.

Paragraph 12.3.: the “accident report” identifies in fact the “minimum set of data” to be transmitted to the PSAP.

Paragraph 12.4.: OICA recommends using the definition proposed for paragraph 2.12. Only one definition is sufficient for the regulation.

Paragraphs 13 and 15.1.1.: It may be of interest to open the possibility of AECS approved to other (national) regulations

Paragraph 15.1.2.: this paragraph needs clarification

Paragraph 15.1.3.: OICA proposes some wording improvement and reference to an annex providing the details of the mobile telephone communication networks of the Contracting Parties signatories to the regulation. In addition, “best possible” reception/communication could be a position at the front of the hood – but this is no crash proof position!

Paragraphs 15.1.4.6. to 15.1.4.10: OICA believes that the paragraphs 15.1.4.6. to 15.1.4.14, including the tables 1-3 should not be part of the regulation or be in a separate annex.

Paragraph 15.1.5.1.: OICA believes it unnecessary to double the provisions of UN R121.

Paragraph 15.1.5.2.: OICA proposes deleting this requirement as it may be detrimental to safety in case the driver faces some disability, linked or not to the accident

Paragraph 15.1.5.3.: This provision is redundant to that of UN R121.

Paragraph 15.1.5.4.: Covered by the amended paragraph 15.1.5.1.

Paragraphs 15.1.6.3. and 15.1.6.4.: OICA believes that UN R121 should regulate HOW the warning signals must be provided (i.e. symbols, illumination and location of the controls and tell-tales), and the AECS regulation should regulate WHEN the warning signals must be provided (i.e. constant when bulb check at engine start, constant during failure, and flashing when operating).

Paragraph 15.1.6.5.: this paragraph can be deleted because its absence would provide the same flexibility.

Paragraph 15.1.7.: covered by the proposed paragraph 15.1.6.3.1.

Paragraph 15.2.3.: the paragraph should address the vehicle rather than its AECS. OICA proposes in the following paragraphs that the AECD, at the occasion of an accident,

- sends batch transmission of data,
- emits a demand for communication, and
- gets reception of external network signals when mobile phone network is simulated.

Paragraph 16: OICA recommends consistency with the paragraphs set out in section 7 (modification of approval of the type of e-call device).

Paragraph 21.1.: the definition is inspired from the Commission delegated Regulation No. 305/2013 supplementing Directive 2010/40/EU.

Paragraph 24.1.: wording inspired from UN R131.

Paragraph 24.1.1.: as proposed per document AECS-01-05

Paragraph 24.1.2. to 24.1.5.2.3.: adaptation of the requirements per paragraphs 15.1. and 15.2.

Paragraph 24.2.1.: contains the main requirements for AECS, i.e. data batch transmission, mobile phone network communication and MSD communication

Paragraph 24.2.2.: requirements for the generation of the triggering signal.

Paragraph 24.3.: OICA believes that the proposed paragraphs secure a proper assessment of the AECS good functioning:

- description of the equipment
- MSD transmission
- Triggering signal generation per performance of frontal/lateral impact or manual control activation, or simulation of these cases.

Addition of annexes related to the approval of the vehicle with regard to its AECS

Annex XXX: proposal for a certificate form to be provided by the applicant in order to produce evidence that the generation of the triggering signal was elaborated in compliance with the requirements of this regulation.

Annex 6 (climate resistance), **Annex 7** (mechanical resistance), **Annex 8** (dynamic test), : these annexes should only apply to the approval of AECD (not to AECS). OICA is keen that presence of these annexes is discussed in detail.

Annex 9 (navigation module): this annex should be technology neutral. Appendix A: there is confusion between “mute” and “unmute”. OICA is keen that presence of this annexe is discussed in detail.

Annex 10 (data exchange protocol): would a simple reference to the relevant standards be sufficient? OICA is keen that presence of this annexe is discussed in detail.

Annex 11 (functional diagnostic tests): this annex is key to the approval of vehicles equipped with AECS. OICA is keen to review this annex in depth, and to consider whether transferring some provisions into the core of the text. OICA is also keen that presence of this annexe is discussed in detail.

Annex 12 (EMC): OICA believes that a reference to the existing UN R10 would be sufficient.

Annex 13 (accident time): this annex should define how simulating the accident which generates the logic signal triggering the e-call process. OICA believes that test reports produced during UN R94 and R95 crash tests should be accepted. In addition, for Contracting Parties where these regulations do not apply, and for vehicles not approved to these regulations, the logic signal should be computer generated according to the specifications provided by the manufacturer.

Annex XXX1: addition of an annex listing the existing mobile telephone communication networks of the Contracting Parties signatory to the regulation.

Annex XXX2: addition of an annex providing information about the PSAP simulated for approving the vehicle.