

Proposal for amendments to UN Regulation No. 46

The text reproduced below has been prepared by the expert from Germany for the first meeting of the second phase of the informal group on camera-monitor-systems (IG CMS-II) to introduce provisions for camera-monitor-systems to be used as devices for indirect vision.

The document is a consolidated version of **UN-R 46/04** including proposed amendments from document **ECE/TRANS/WP.29/GRSG/2011/23/Rev.1**. Additional provisions for camera-monitor-systems were added in a new annex.

The modifications to the current text of the Regulation are marked in bold for new or strikethrough for deleted characters.

I. Proposal

Regulation No. 46

UNIFORM PROVISIONS CONCERNING THE APPROVAL OF DEVICES FOR INDIRECT VISION AND OF MOTOR VEHICLES WITH REGARD TO THE INSTALLATION OF THESE DEVICES

Contents

Regulation

1.	Scope	
I.	Devices for indirect vision.....	4
2.	Definitions	4
3.	Application for approval	7
4.	Markings.....	7
5.	Approval.....	7
6.	Requirements	8
7.	Modification of the type of device for indirect vision and extension of approval	19
8.	Conformity of production	19
9.	Penalties for non-conformity of production	20
10.	Production definitively discontinued	20
11.	Names and addresses of Technical Services responsible for conducting approval tests, and of Type Approval Authorities	20
II.	Installation of devices for indirect vision	20
12.	Definitions	20
13.	Application for approval	21
14.	Approval	22
15.	Requirements	22
16.	Modifications of the vehicle type and extension of approval	37
17.	Conformity of production	38
18.	Penalties for non-conformity of production	38
19.	Production definitively discontinued	38

20.	Names and addresses of Technical Services responsible for conducting approval tests, and of Type Approval Authorities	38
21.	Transitional provisions	38

Annexes

Annex 1	Information document for type approval of a device for indirect vision	41
Annex 2	Information document for type-approval of a vehicle with respect to the installation of devices for indirect vision	42
Annex 3	Communication concerning the approval or refusal or extension or withdrawal of approval or production definitely discontinued of a type of device for indirect vision, pursuant to Regulation No. 46	44
Annex 4	Communication concerning the approval or refusal or extension or withdrawal of approval or production definitely discontinued of a vehicle type with regard to the installation of devices for indirect vision, pursuant to Regulation No. 46	46
Annex 5	Arrangement of approval mark of a device for indirect vision	48
Annex 6	Test method for determining reflectivity	49
Annex 7	Procedure for determining the radius of curvature „r“ of the reflecting surface of a mirror	55
Annex 8	Procedure for determining the "H" point and the actual torso angle for seating positions in motor vehicles	57
	Annex 8 - Appendix 1 Description of the three dimensional "H" point machine (3-D H machine)	57
	Annex 8 - Appendix 2 Three-dimensional reference system	57
	Annex 8 - Appendix 3 Reference data concerning seating positions	57
Annex 9	(Reserved)	58
Annex 10	Calculation of the detection distance	59
Annex 11	Determination of the displayed object size	63
Annex xx	Provisions for the type approval of camera-monitor devices (CMS) of class I to IV [and VII] field of vision	XX

Regulation No. 46

UNIFORM PROVISIONS CONCERNING THE APPROVAL OF DEVICES FOR INDIRECT VISION AND OF MOTOR VEHICLES WITH REGARD TO THE INSTALLATION OF THESE DEVICES

1. Scope

This Regulation applies:

- (a) To compulsory and optional devices for indirect vision, set out in the table under paragraph 15.2.1.1.1. for vehicles of category M and N ¹⁾ and to compulsory and optional devices for indirect vision mentioned in paragraphs 15.2.1.1.3 and 15.2.1.1.4 for vehicles of category L ¹⁾ with bodywork at least partly enclosing the driver;
- (b) To the installation of devices for indirect visions on vehicles of categories M and N and on vehicles of category L ¹⁾ with bodywork at least partly enclosing the driver.

I. DEVICES FOR INDIRECT VISION

2. Definitions

For the purposes of this Regulation:

- 2.1. ~~“Devices for indirect vision” means devices to observe the traffic area adjacent to the vehicle which cannot be observed by direct vision~~ **intended to give a clear view to the rear, side or front of the vehicle within the fields of vision defined in paragraph 15.2.4.** These can be conventional mirrors, camera-monitors or other devices able to present information about the indirect field of vision to the driver.
- 2.1.1. **“Mirror”** means any device, excluding devices such as periscopes, intended to give a clear view to the rear, side or front of the vehicle within the fields of vision defined in paragraph 15.2.4. **by means of a reflective surface.**
- 2.1.1.1. **“Interior mirror”** means a device as defined in paragraph ~~2.1.~~, **2.1.1.**, which can be fitted in the passenger compartment of a vehicle.
- 2.1.1.2. **“Exterior mirror”** means a device as defined in paragraph ~~2.1.~~, **2.1.1.**, which can be mounted on the external surface of a vehicle.
- 2.1.1.3. **“Surveillance mirror”** means a mirror other than the ones defined in paragraph 2.1.1. which can be fitted to the inside or outside of the vehicle in order to provide fields of vision other than those specified in paragraph 15.2.4.
- 2.1.1.4. **“r”** means the average of the radii of curvature measured over the reflecting surface, in accordance with the method described in Annex 7.

¹⁾ As defined in the Consolidated Resolution on the Construction of Vehicles (R.E.3.), document ECE/TRANS/WP.29/78/Rev.2, para. 2.

2)

2.1.1.5. "The principal radii of curvature at one point on the reflecting surface (r_i)" means the values obtained with the apparatus defined in Annex 7, measured on the arc of the reflecting surface passing through the centre of this surface parallel to the segment b, as defined in paragraph 6.1.2.1.2.1. and on the arc perpendicular to this segment.

2.1.1.6. "The radius of curvature at one point on the reflecting surface (r_p)" means the arithmetical average of the principal radii of curvature r_i and r_i' i.e.:

$$r_p = \frac{r_i + r_i'}{2}$$

2.1.1.7. "Spherical surface" means a surface, which has a constant and equal radius in all directions.

2.1.1.8. "Aspherical surface" means a surface, which has only in one plane a constant radius.

2.1.1.9. "Aspherical mirror" means a mirror composed of a spherical and an aspherical part, in which the transition of the reflecting surface from the spherical to the aspherical part has to be marked. The curvature of the main axis of the mirror is defined in the x/y coordinate system defined by the radius of the spherical primary calotte with:

$$y = R \sqrt{R^2 - x^2} + k(x - a)^3$$

-
- R: nominal radius in the spherical part
- k: constant for the change of curvature
- a: constant for the spherical size of the spherical primary calotte
- 2.1.1.10. "*Centre of the reflecting surface*" means the centre of the visible area of the reflecting surface.
- 2.1.1.11. "*The radius of curvature of the constituent parts of the mirror*" means the radius "c" of the arc of the circle which most closely approximates to the curved form of the part in question.
- ~~2.1.1.13. "*Class of mirror*" means all devices having one or more common characteristics or functions. They are classified as follows:~~
- ~~(a) Class I: "*Interior rear view mirror*", giving the field of vision defined in paragraph 15.2.4.1;~~
 - ~~(b) Class II and III: "*Main exterior rear view mirror*", giving the fields of vision defined in paragraphs 15.2.4.2. and 15.2.4.3;~~
 - ~~(c) Class IV: "*Wide angle exterior mirror*", giving the field of vision defined in paragraph 15.2.4.4;~~
 - ~~(d) Class V: "*Close proximity exterior mirror*", giving the field of vision defined in paragraph 15.2.4.5;~~
 - ~~(e) Class VI: "*Front mirror*", giving the field of vision defined in paragraph 15.2.4.6;~~
 - ~~(f) Class VII: "*Mirrors intended for L category vehicles with bodywork*", giving the field of vision defined in paragraph 15.2.4.7.~~
- 2.1.2. "*Camera-monitor device for indirect vision*" means a device as defined in paragraph 2.1., where the field of vision is obtained by means of a camera-monitor combination as defined in paragraphs 2.1.2.1. and 2.1.2.2.
- 2.1.2.1. "*Camera*" means a device that renders an image of the outside world and then converts this image into a signal (e.g. video signal).
- 2.1.2.2. "*Monitor*" means a device that converts a signal into images that are rendered into the visual spectrum.
- ~~2.1.2.3. "*Detection*" means the ability to distinguish an object from its background/surroundings at certain distance.~~
- 2.1.3. "*Other devices for indirect vision*" means devices as defined in paragraph 2.1, where the field of vision is not obtained by means of a mirror or a camera-monitor ~~type device for indirect vision.~~
- 2.1.4. "Vision support system" means a system to enable the driver to detect and/or see objects in the area adjacent to the vehicle.
- 2.1.5. "*Luminance contrast*" means the brightness ratio between an object and its immediate background/surrounding that allows the object to be distinguished from its background/surroundings.

2.1.6. "Resolution" means the smallest detail that can be discerned with a perceptual system, i.e. perceived as separate from the larger whole. The resolution of the human eye is indicated as "visual acuity".

2.1.7. **"Critical object" means a cylindrical object. For devices for Class V and VI it shall be 0.5 m high and with a diameter $D_0 = 0.3$ m. For Classes I to IV and VII the dimensions shall be [.....] ¹**

~~2.1.7.1.~~

2.1.8. "Critical perception" means the level of perception that can just be obtained under critical conditions via the viewing system used. This corresponds to the situation in which the representative scale of the critical object is multiple times larger than the smallest detail that can be perceived via the viewing system

~~2.1.8.1.~~ 2.1.9 "Field of vision" means the section of the tri-dimensional space which is monitored with the help of a device for indirect vision. Unless otherwise stated, this is based on the view on ground level offered by a device and/or devices other than mirrors. This may be limited by the relevant detection distance corresponding to the critical object.

~~2.1.8.2. "Critical object" means a cylindrical object with a height of 0.50 m and a diameter of 0.30 m.~~

2.1.10

~~2.1.8.3.~~ "Detection distance" means the distance measured from the centre of the lens of the camera to the point at which a critical object can just be perceived (as defined by the critical perception).

~~2.1.8.4.~~ (Reserved)

~~2.1.8.5.~~ (Reserved)

¹ The critical object needs to be yet defined, preferably by ISO.

2.1.11.

~~2.1.8.6.~~—"Visual spectrum" means light with a wavelength within the range of the perceptual limits of the human eyes: 380-780 nm.

2.1.12. "Smear" is a vertical bright bar displayed on the monitor while sun light or light from other bright light sources is directly hitting into the lens of the camera. Smear is an optical artefact.

2.2. "Type of device for indirect vision" means devices that do not differ on the following essential characteristics:

- (a) design of the device inclusive, if pertinent, the attachment to the bodywork;
- (b) in case of mirrors the class, the shape, the dimensions and radius of curvature of the mirror's reflecting surface;
- (c) in case of camera-monitor devices, the class. ~~the detection distance and the range of vision~~

2.3

~~2.1.8.7.~~—"Surveillance camera-monitor-recording device" means a camera and either a monitor or recording equipment other than the camera-monitor device defined in paragraph 2.1.2. which can be fitted to the inside or outside of the vehicle in order to provide fields of vision other than those specified in paragraph 15.2.4. or to provide a security system within or around the vehicle.

~~2.1.8.8.~~—"Smear" is a vertical bright bar displayed on the monitor while sun light or light from other bright light sources is directly hitting into the lens of the camera. Smear is an optical artefact.

2.1.9. "~~Other devices for indirect vision~~" means ~~devices as defined in paragraph 2.1., where the field of vision is not obtained by means of a mirror or a camera-monitor-type device for indirect vision.~~

2.1.10. "~~Type of device for indirect vision~~" means ~~devices that do not differ on the following essential characteristics:~~

- ~~a) Design of the device inclusive, if pertinent, the attachment to the bodywork;~~
- ~~b) In case of mirrors the class, the shape, the dimensions and radius of curvature of the mirror's reflecting surface;~~
- ~~c) In case of camera-monitor devices the detection distance and the range of vision.~~

2.4. "Class of ~~mirror~~ device for indirect vision" means all devices having one or more common characteristics or functions. They are classified as follows:

2.4.1. Class I: "**Interior Central rear-view mirror device**", giving the field of vision defined in paragraph 15.2.4.1.

2.4.2. Class II and III: "**Main exterior rear-view device mirror**", giving the fields of vision defined in paragraphs 15.2.4.2. and 15.2.4.3.

2.4.3. Class IV: "**Wide-angle view device exterior mirror**", giving the field of vision defined in paragraph 15.2.4.4.

2.4.5. Class V: "**Close-proximity view device exterior mirror**", giving the field of vision defined in paragraph 15.2.4.5.

2.4.6. Class VI: "**Front-view device mirror**", giving the field of vision defined in paragraph 15.2.4.6.

2.4.7. Class VII: ~~Mirrors~~ Main rear-view devices intended for L category vehicles with bodywork **giving the field of vision defined in paragraph 15.2.4.7**

3. Application for approval

- 3.1. The application for approval of a type of device for indirect vision shall be submitted by the holder of the trade name or mark or by his duly accredited representative.
- 3.2. A model of information document is shown in Annex 1.
- 3.3. For each type of device for indirect vision the application shall be accompanied by: **three samples of the parts."**
- ~~3.3.1. In case of mirrors, four samples: three for use in the tests and one to be retained by the laboratory for any further examination that might subsequently prove necessary. Additional specimens may be called for at the request of the laboratory;~~
- ~~3.3.2. In case of other devices for indirect vision: one sample of all the parts.~~

4. Markings

- 4.1. The samples of devices for indirect vision submitted for approval shall bear the trade name or mark of the manufacturer; this marking shall be clearly legible and be indelible.
- 4.2. Every device **for indirect vision, with the exception of original Cameramonitor devices**, shall possess **on at least one of the main components** a space large enough to accommodate the approval mark, which ~~must~~ **shall** be legible when the device has been mounted on the vehicle; this space shall be shown on the drawings referred to in Annex 1. **Other components of the device shall bear the name of the manufacturer and a means of identification. In case of limited space for the approval mark(s), other means of identification that link it to the approval number mark shall be provided.**

[Or alternative text from GRSG-102-04:

- 4.2. *Every device for indirect vision, shall possess on at least one of the main components of its protective housing a space large enough to accommodate the approval mark, which must shall be legible when the device has been mounted on the vehicle; this space shall be shown on the drawings referred to in Annex 1. Other components of the device shall bear the name of the manufacturer and a means of identification. In case of limited or no space for the approval mark(s) or when the approval mark(s) cannot be legible when the device has been mounted on the vehicle, the provisions of paragraph 5.7. may be applied as an alternative.]*

5. Approval

- 5.1. If the samples submitted for approval meet the requirements of paragraph 6. of this Regulation, approval of the pertinent type of device for indirect vision shall be granted.
- 5.2. An approval number shall be assigned to each type approved. Its first two digits

(at present 04) shall indicate the series of amendments incorporating the most recent major technical amendments made to the Regulation at the time of issue of the approval. The same Contracting Party shall not assign the same number to another type of device for indirect vision.

- 5.3. Notice of approval or of refusal or of extension or withdrawal of approval or of production definitively discontinued of a type of device for indirect vision pursuant to this Regulation shall be communicated to the Parties to the Agreement which apply this Regulation by means of a form conforming to the model in Annex 3 to this Regulation.
- 5.4. There shall be affixed **on at least one of the main components**, conspicuously and in the space referred to in paragraph 4.2. above, to every device for indirect vision, **with the exception of original Camera-monitor devices for indirect vision**, conforming to a type approved under this Regulation, in addition to the mark prescribed in paragraph 4.1., an international approval mark consisting of:

[Or alternative text from GRSG-101-03:

- 5.4. *There shall be affixed on at least one of the main components, conspicuously and in the space referred to in paragraph 4.2. above, to every device for indirect vision, conforming to a type approved under this Regulation, in addition to the mark prescribed in paragraph 4.1., an international approval mark consisting of:]*
- 5.4.1. A circle surrounding the letter "E" followed by the distinguishing number of the country which has granted approval ²⁾;
- 5.4.2. An approval number;
- 5.4.3. ~~An~~ **Additional** symbol(s) I or II or/and III or/and IV or/and V or/and VI or/and VII, specifying the class to which the type of the ~~mirror~~ devices for indirect vision belongs ~~or the symbol S in case of any device for indirect vision other than a mirror~~. The additional symbol shall be placed in any convenient position in the vicinity of the circle containing the letter "E".
- 5.5. The approval mark and the additional symbol(s) shall be clearly legible and be indelible.
- 5.6. Annex 5 to this Regulation gives an example of the arrangement of the aforesaid approval mark and additional symbol.

[As an alternative text from GRSG-101-03: Insert new paragraph 5.7., to read:

"5.7. As an alternative to the approval mark described in paragraph 5.4. above, a certificate of conformity shall be issued for device for indirect vision offered for sale.

Where a device for indirect vision manufacturer supplies an approved unmarked system to a vehicle manufacturer, for fitment by that manufacturer as original equipment for a vehicle model or range of vehicle models, the device for indirect vision manufacturer shall supply a number of copies of the certificate of conformity to the vehicle manufacturer, sufficient for that manufacturer to obtain the vehicle approval to Part II of this Regulation.

If the device for indirect vision is made up of separate components, its main component(s) shall bear a reference mark and the certificate of conformity shall provide a list of such reference marks.

A model of the certificate of conformity is given in Annex 11 to this Regulation."]

6. Requirements

- 6.1. Mirrors

6.1.1. General specifications

6.1.1.1. All mirrors shall be adjustable.

6.1.1.2. The edge of the reflecting surface must be enclosed in a protective housing (holder, etc.) which, on its perimeter, must have a value "c" greater than or equal to 2.5 mm at all points and in all directions. If the reflecting surface projects beyond the protective housing, the radius of curvature "c" on the edge of the projecting part must be not less than 2.5 mm and the reflecting surface must return into the protective housing under a force of 50 N applied to the point of greatest projection, relative to the protective housing, in a horizontal direction, approximately parallel to the longitudinal median plane of the vehicle.

6.1.1.3. When the mirror is mounted on a plane surface, all parts, irrespective of the adjustment position of the device, including those parts remaining attached to the support after the test provided for in paragraph 6.3.2., which are in potential, static contact with a sphere either 165 mm in diameter in the case of an interior mirror or 100 mm in diameter in the case of an exterior mirror, must have a radius of curvature 'c' of not less than 2.5 mm.

6.1.1.4. The requirements in paragraphs 6.1.1.2. and 6.1.1.3. shall not apply to parts of the external surface which protrude less than 5 mm, but the outward facing angles of such parts shall be blunted, save where such parts protrude less than 1.5 mm. For determining the dimension of the projection, the following method shall apply:

³⁾ The distinguish numbers of the Contracting Parties to the 1958 Agreement are reproduced in Annex 3 to Consolidated Resolution on the Construction of Vehicles (R.E.3), document ECE/TRANS/WP.29/78/Rev.2/Amend.1.

6.1.1.4.1. The dimension of the projection of a component which is mounted on a convex surface may be determined either directly or by reference to a drawing of an appropriate section of this component in its installed condition.

6.1.1.4.2. If the dimension of the projection of a component which is mounted on a surface other than convex cannot be determined by simple measurement, it shall be determined by the maximum variation of the distance of the centre of a 100 mm diameter sphere from the nominal line of the panel when the sphere is moved over and is in constant contact with that component. Figure 1 shows an example of the use of this procedure.

Figure 1

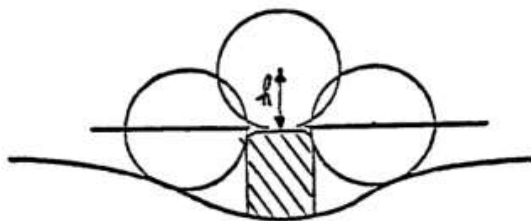

6.1.1.5. Edges of fixing holes or recesses of which the diameter or longest diagonal is less than 12 mm are exempt from the radius requirements of paragraph 6.1.1.3. provided that they are blunted.

6.1.1.6. The device for the attachment of mirrors to the vehicle must be so designed that a cylinder with a 70 mm radius (50 mm in the case of an L-category vehicle), having as its axis the axis, or one of the axes, of pivot or rotation which ensures deflection of the mirror in the direction of impact concerned, passes through at least part of the surface to which the device is attached.

6.1.1.7. The parts of exterior mirrors referred to in paragraphs 6.1.1.2. and 6.1.1.3. which are made of a material with a Shore A hardness not exceeding 60 are exempt from the relevant provisions.

6.1.1.8. In the case of those parts of interior mirrors which are made of a material with a Shore A hardness of less than 50 and which are mounted on a rigid support, the requirements of paragraphs 6.1.1.2. and 6.1.1.3. shall only apply to the support.

6.1.2. Special specifications

6.1.2.1. Dimensions

6.1.2.1.1. ~~Interior~~ **Central** rear-view **interior** mirrors (Class I)

The dimensions of the reflecting surface must be such that it is possible to inscribe thereon a rectangle one side of which is 40 mm and the other 'a' mm in length, where

$$a = 150 \times \frac{1}{1 + \frac{1000}{r}} \text{ mm}$$

and "r" is the radius of curvature.

6.1.2.1.2. Main ~~exterior~~ rear-view **exterior** mirrors (Classes II and III)

6.1.2.1.2.1. The dimensions of the reflecting surface must be such that it is possible to inscribe therein:

- (a) A rectangle 40 mm high the base length of which, measured in millimetres, has the value "a";
- (b) A segment which is parallel to the height of the rectangle and the length of which, expressed in millimetres, has the value "b".

6.1.2.1.2.2. The minimum values of 'a' and 'b' are given in the table below:

Class of rear-view mirror	a (mm)	b (mm)
II	$\frac{170}{1 + \frac{1000}{r}}$	200
III	$\frac{130}{1 + \frac{1000}{r}}$	70

6.1.2.1.3. "Wide-angle" **view** exterior mirrors (Class IV)

The contours of the reflecting surface must be of simple geometric form and its dimensions such that it provides, if necessary in conjunction with a Class II exterior mirror, the field of vision specified in paragraph 15.2.4.4.

6.1.2.1.4. "Close-proximity" **view** exterior mirrors (Class V)

The contours of the reflecting surface must be of simple geometric form and its dimensions such that the mirror provides the field of vision specified in paragraph 15.2.4.5.

6.1.2.1.5. Front **view** mirrors (Class VI)

The contours of the reflecting surface must be of simple geometric form and its dimensions such that the mirror provides the field of vision specified in paragraph 15.2.4.6.

6.1.2.1.6. Mirrors for Category L vehicles with bodywork (Class VII)

6.1.2.1.6.1. "Main" **rear view** exterior mirrors (Class VII)

The minimum dimensions of the reflecting surface shall be such that:

- (a) Its area shall not be less than 6 900 mm²;
- (b) The diameter of circular mirrors shall not be less than 94 mm;
- (c) Where rear view mirrors are not circular, their dimensions shall enable a 78 mm-diameter circle to be prescribed on their reflecting surface.

The maximum dimensions of the reflecting surface shall be such that:

- (a) The diameter of any circular rear view mirror shall not be greater than 150 mm;
- (b) The reflecting surface of any non-circular rear view mirror shall lie within a rectangle measuring 120 mm x 200 mm.

6.1.2.2. Reflecting surface and coefficients of reflection

6.1.2.2.1. The reflecting surface of a mirror must be either flat or spherically convex. Exterior mirrors may be equipped with an additional aspherical part provided that the main mirror fulfils the requirements of the indirect field of vision.

6.1.2.2.2. Differences between the radii of curvature of mirrors

6.1.2.2.2.1. The difference between r_i or r'_i , and r_p at each reference point must not exceed 0.15 r .

6.1.2.2.2.2. The difference between any of the radii of curvature (r_{p1} , r_{p2} , and r_{p3}) and r must not exceed 0.15 r .

6.1.2.2.2.3. When r is not less than 3,000 mm, the value of 0.15 r quoted in paragraphs 6.1.2.2.2.1. and 6.1.2.2.2.2. is replaced by 0.25 r .

6.1.2.2.3. Requirements for aspherical parts of mirrors

6.1.2.2.3.1. Aspherical mirrors shall be of sufficient size and shape to provide useful information to the driver. This normally means a minimum width of 30 mm at some point.

6.1.2.2.3.2. The radius of curvature r_i of the aspherical part shall not be less than 150 mm.

6.1.2.2.4. Value of 'r' for spherical mirrors must not be less than:

6.1.2.2.4.1. 1,200 mm for interior rear-view mirrors (Class I);

6.1.2.2.4.2. 1,200 mm for Class II and III main exterior rear-view mirrors;

6.1.2.2.4.3. 300 mm for "wide-angle" exterior mirrors (Class IV) and "close-proximity" exterior mirrors (Class V);

6.1.2.2.4.4. 200 mm for front mirrors (Class VI).

6.1.2.2.4.5. 1,000 mm or more than 1,500 mm in the case of Class VII mirrors

6.1.2.2.5. The value of the normal coefficient of reflection, as determined according to the method described in Annex 6, must be not less than 40 per cent.

In the case of reflecting surfaces with a changeable degree of reflection, the "day" position must allow the colours of the signals used for road traffic to be recognized. The value of the normal coefficient of reflection in the "night" position must be not less than 4 per cent.

6.1.2.2.6. The reflecting surface must retain the characteristics laid down in paragraph 6.1.2.2.5. in spite of prolonged exposure to adverse weather conditions in normal use.

6.2. Devices for indirect vision other than mirrors

6.2.1. General requirements

6.2.1.1. If adjustment by the user is needed, the device for indirect vision shall be adjustable without the use of tools.

6.2.1.2. If a device for indirect vision can only render the total prescribed field of vision by scanning the field of vision, the total process of scanning, rendering and reset to its initial position together shall not take more than 2 seconds.

6.2.2. Camera-monitor devices ~~for indirect vision~~

6.2.2.1. General requirements

6.2.2.1.1. When the camera-monitor device ~~for indirect vision~~ is mounted ~~on a plane surface in the intended installation position~~, all parts, irrespective of the adjustment position of the device which are in potential, static contact with a sphere either 165 mm in diameter in the case of parts fitted in the interior or 100 mm in diameter in the case of parts fitted to the exterior, must have a radius of curvature "c" of not less than 2.5 mm. **This does not apply to exterior parts of such devices which are installed 2.00 m or more above the ground.**

Parts complying with Regulation No. 21 or Regulation No. 26 are deemed to satisfy the relevant requirements above.

6.2.2.1.2. Edges of fixing holes or recesses of which the diameter or longest diagonal is less than 12 mm are exempt from the radius requirements of paragraph 6.2.2.1.1. provided that they are blunted.

6.2.2.1.3. For parts of the camera and the monitor which are made of a material with a

Shore A hardness of less than 60 and which are mounted on a rigid support, the requirements of paragraph 6.2.2.1.1. shall only apply to the support.

6.2.2.2. Functional requirements **for camera monitor devices of class V and VI**

6.2.2.2.1. The camera shall function well in conditions in which sunlight falls on the camera. The saturated area, defined as the area in which the luminance contrast ratio ($C = L_w/L_b$) of a high contrast pattern falls below 2.0, shall not cover more than 15 per cent of the displayed image under the conditions of paragraph 6.2.2.2.1.1. to 6.2.2.2.1.4.

In case the camera system shows dynamical changes in the blooming area during the test the maximum blooming area should fulfill the requirement.

6.2.2.2.1.1. A black and white test pattern, having a minimum contrast ratio of 20 shall be positioned in front of the camera.

The test pattern shall be evenly illuminated at an illumination of 3000 ± 300 Lx.

The test pattern shall be medium gray on average and cover the complete area viewed by the camera; the camera shall view no other objects than the test pattern.

6.2.2.2.1.2. The camera shall be hit by a (simulated sun) light of 40 kLx, spanning an angle between 0.6 and 0.9 degrees with an elevation angle of 10 degrees (directly or indirectly via a mirror) removed from the optical axis of the sensor.

The light source shall:

- (a) Have a spectrum D65 with a tolerance of ± 1500 K,
- (b) Be homogeneous in space and time within a tolerance of 2 kLx.

The emission of the light source in infrared shall be negligible.

6.2.2.2.1.3. There shall be no ambient illumination of the monitor during the test.

6.2.2.2.1.4. An example of the set-up is given in the figure A below.

Figure A

Diagram of the blooming measurement set-up

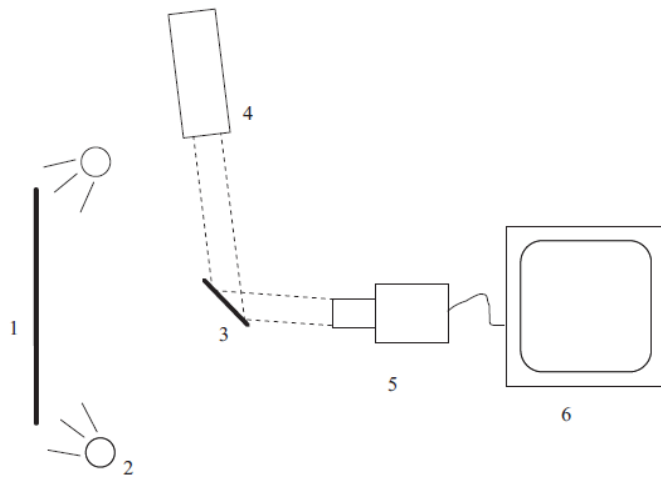

- 1: Black & white test pattern.
- 2: Lamps to make the test pattern evenly illuminated.
- 3: Mirror.
- 4: High intensity light.
- 5: Camera. 6: Monitor.

- 6.2.2.2.2. The monitor shall render a minimum contrast under various light conditions as specified by ISO 15008:2003.
- 6.2.2.2.3. It shall be possible to adjust the average luminance of the monitor either manually or automatically to the ambient conditions.
- 6.2.2.2.4. The measurements for the luminance contrast of the monitor shall be carried out according to ISO 15008:2009.

~~6.2.2.2.5~~-6.2.2.3. The camera-monitor devices of Class I to IV [and VII] shall meet the provisions of annex XX .

6.2.3. Other devices for indirect vision

It has to be proved that the device meets the following requirements:

- 6.2.3.1. The device shall perceive the visual spectrum and shall always render this image without the need for interpretation into the visual spectrum.
- 6.2.3.2. The functionality shall be guaranteed under the circumstances of use in which the system shall be put into service. Depending on the technology used in obtaining images and presenting them paragraph 6.2.2.2. shall be entirely or partly applicable. In other cases this can be achieved by establishing and demonstrating by means of system sensitivity analogous to paragraph 6.2.2.2. that a function is ensured that is comparable to or better than what is required for and by demonstrating that a functionality is guaranteed that is equivalent or better than that required for mirror- or camera-monitor type devices for indirect vision.

6.3. Test

6.3.1. Mirrors Devices for indirect vision in Classes I to VI and Class VII (having fittings identical to Class III) shall be subjected to the tests described in paragraphs **6.3.2.1. and 6.3.2.2.** Class VII mirrors with a stem, shall be subjected to the tests described in paragraph **6.3.2.3.**

6.3.1.1. The test provided for in paragraph 6.3.2 shall not be required in the case of any exterior ~~mirror~~ **device for indirect vision** of which no part is less than 2 m from the ground, regardless of the adjustment position, when the vehicle is under a load corresponding to its maximum technically permissible mass.

This derogation also applies to the attachments of ~~mirrors~~ **devices for indirect vision** (attachment plates, arms, swivel joints, etc.) which are situated less than 2 m from the ground and which do not project beyond the overall width of the vehicle, measured in the transverse plane passing through the lowest mirror attachments or any other point forward of this plane if this configuration produces a greater overall width.

In such cases, a description specifying that the ~~mirror~~ **device for indirect vision** must be mounted so as to conform to the above-mentioned conditions for the positioning of its attachments on the vehicle must be provided.

Where advantage is taken of this derogation, the arm shall be indelibly marked with the symbol

$\frac{\Delta}{2m}$

and the type-approval certificate shall be endorsed to this effect."

6.3.2. Impact test

The test according to this paragraph is not to be carried out for devices integrated in the bodywork of the vehicle and providing a frontal deflecting area of an angle not more than 45° measured in relation to the longitudinal median plane of the vehicle, or devices not protruding more than 100 mm measured beyond the circumscribing bodywork of the vehicle according to Regulation No. 26.

6.3.2.1. Description of the test rig

6.3.2.1.1. The test rig consists of a pendulum capable of swinging about two horizontal axes at right angles to each other, one of which is perpendicular to the plane containing the "release" trajectory of the pendulum.

The end of the pendulum comprises a hammer formed by a rigid sphere with a diameter of 165 ± 1 mm having a 5 mm thick rubber covering of Shore A hardness 50.

A device is provided which permits determination of the maximum angle assumed by the arm in the plane of release.

A support firmly fixed to the structure of the pendulum serves to hold the specimens in compliance with the impact requirements specified in paragraph 6.3.2.2.6.

Figure 1 below gives the dimensions (in mm) of the test rig and the special design specifications:

Figure 1

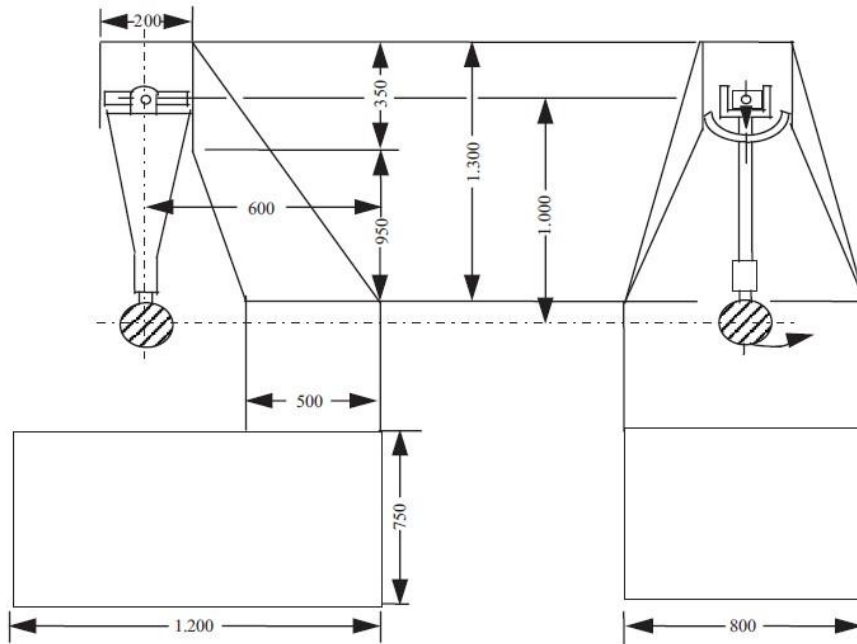

- 6.3.2.1.2. The centre of percussion of the pendulum coincides with the centre of the sphere, which forms the hammer. It is at a distance l from the axis of oscillation in the re-lease plane, which is equal to $1\text{ m} \pm 5\text{ mm}$. The reduced mass of the pendulum is $m_o = 6.8 \pm 0.05$ kilograms. The relationship of m_o to the total mass m of the pen- dulum and to the distance d between the centre of gravity of the pendulum and its axis of rotation is expressed in the equation:

$$m_o = m \times \frac{d}{l}$$

6.3.2.2. Description of the test

6.3.2.2.1. The procedure used to clamp the **mirror device for indirect vision** to the support shall be that recommended by the manufacturer of the device or, where appropriate, by the vehicle manufacturer.

6.3.2.2.2. Positioning of the **mirror device for indirect vision** for the test:

6.3.2.2.2.1. **Mirrors Devices for indirect vision** shall be positioned on the pendulum impact rig in such a way that the axes which are horizontal and vertical when the **mirror device for indirect vision** is installed on a vehicle in accordance with the applicant's mounting instructions are in a similar position;

6.3.2.2.2.2. When a **mirror device for indirect vision** is adjustable ...by the applicant;

6.3.2.2.2.3. When the **mirror device for indirect vision** has a device... is shortest;

6.3.2.2.2.4. **In case of mirrors**, when the reflecting surface...to the housing.

6.3.2.2.3. **In case of mirrors**, except in the case of test 2 for interior mirrors (see paragraph 6.3.2.2.7.1.), when the pendulum ... as defined in paragraph 2.4.4.44 2.1.1.10. The longitudinal ...vehicle."

6.3.2.2.4. **In case of camera-monitor-systems**, when the pendulum is in a vertical position the horizontal and longitudinal vertical planes passing through the centre of the hammer shall pass through the centre of the lens or of the transparent protection part in front of the lens. The longitudinal direction of oscillation of the pendulum shall be parallel to the longitudinal median plane of the vehicle. If the test is performed with a shutter camera system, the shutter has to be open during the pendulum impact.

6.3.2.2.5. When, under the conditions governing adjustment laid down in paragraphs 6.3.2.2.1. and 6.3.2.2.2. parts of the ~~mirror~~ **device for indirect vision** limit the return of the hammer, the point of impact must be displaced in a direction perpendicular to the axis of rotation or pivoting in question.

The displacement must be no greater than is strictly necessary for the execution of the test; it must be limited in such a way that:

- (a) either the sphere delimiting the hammer remains at least tangential to the cylinder as defined in paragraph 6.1.1.5.;
- (b) or, **in case of mirrors**, the point of contact with the hammer is located at least 10 mm from the periphery of the reflecting surface.

6.3.2.2.6. The test consists in allowing the hammer to fall from a height corresponding to a pendulum angle of 60° from the vertical so that the hammer strikes the ~~mirror~~ **device for indirect vision** at the moment when the pendulum reaches the vertical position.

6.3.2.2.7. The ~~mirrors~~ **devices for indirect vision** are subjected to impact under the following different conditions:

6.3.2.2.7.1. Interior mirrors

- (a) Test 1: The points of impact shall be as defined in paragraph 6.3.2.2.3. The impact must be such that the hammer strikes the mirror on the reflecting surface side.
- (b) Test 2: Point of impact on the edge of the protective housing, such that the impact produced makes an angle of 45° with the plane of the reflecting surface and is situated in the horizontal plane passing through the centre of that surface. The impact must occur on the reflecting surface side.

6.3.2.2.7.2. Exterior mirrors

- (a) Test 1: The point of impact shall be as defined in paragraph 6.3.2.2.3. **or 6.3.2.2.5.** The impact must be such that the hammer strikes the mirror on the reflecting surface side.
- (b) Test 2: The point of impact shall be as defined in paragraph 6.3.2.2.3. **or 6.3.2.2.5.** The impact must be such that the hammer strikes the mirror on the side opposite to the reflecting surface.

Where Class II or III rear-view mirrors are fixed to the same mounting as Class IV rear-view mirrors, the above-mentioned tests shall be executed on the lower mirror. Nevertheless, the Technical Service responsible for testing may

repeat one or both of these tests on the upper mirror if this is less than 2 m from the ground."

6.3.2.2.7.3. Camera-Monitor-Systems

- (a) **Test 1: The point of impact shall be as defined in paragraph 6.3.2.2.4. or 6.3.2.2.5. The impact must be such that the hammer strikes the camera on the lens side.**
- (b) **Test 2: The point of impact shall be as defined in paragraph 6.3.2.2.4. or 6.3.2.2.5. The impact must be such that the hammer strikes the camera on the side opposite to the lens.**

Where more than one camera is fixed to the same mounting, the above-mentioned tests shall be executed on the lower camera. Nevertheless, the Technical Service responsible for testing may repeat one or both of these tests on the upper camera if this is less than 2 m from the ground.

6.3.2.3. Bending test on the protective housing attached to the stem (Class VII)

6.3.2.3.1. Description of test

The protective housing is placed horizontally in a device in such a way that it is possible to lock the attachment support adjusters firmly. In the direction of the largest dimension of the housing, the end closest to the point of attachment on the adjuster for the support shall be immobilized by a 15 mm-wide rigid stop covering the entire width of the housing.

At the other end, a stop identical to the one described above is placed on the housing so that the specified test load can be applied to it (Figure 2).

The end of the housing opposite to that where the force is exerted may be locked rather than held in position as shown in Figure 2.

Figure 2

Example of rear view mirror bending-test rig

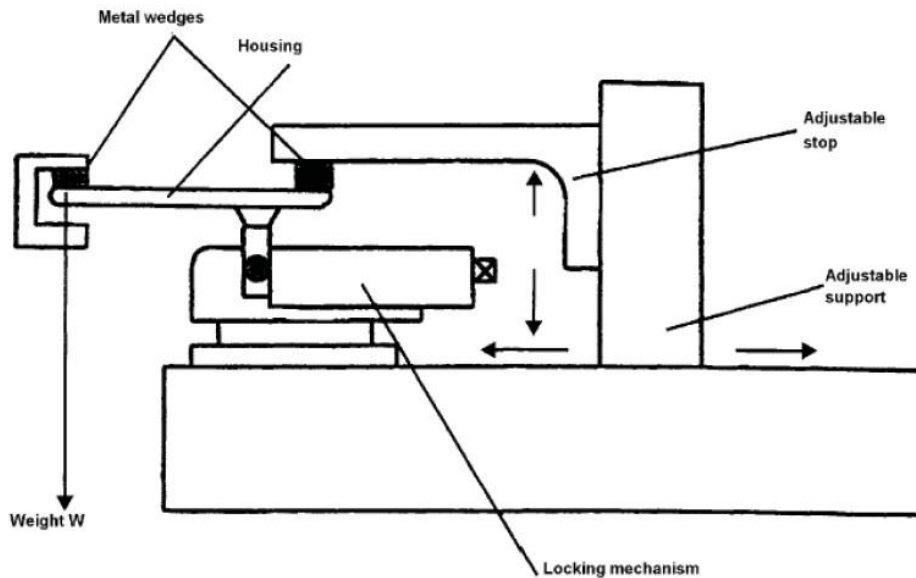

6.3.2.3.2. The test loading shall be 25 kilograms and shall be maintained for one minute.

6.3.3. *Results of the tests*

In the tests described in paragraph 6.3.2., the pendulum must continue to swing after impact in such a way that the projection of the position assumed by the arm on the plane of release makes an angle of at least 20° with the vertical. The accuracy of measurement of the angle shall be within ± 1 .

6.3.3.1.1. **In case of mirrors**, this requirement is not applicable to mirrors stuck to the windscreen, in respect of which the requirement stipulated in paragraph 6.3.3.2. shall apply after the test.

6.3.3.1.2. The required angle to the vertical is reduced from 20° to 10° for all Class II and Class IV ~~rear-view mirrors~~ **devices for indirect vision** and for Class III ~~rear-view mirrors~~ **devices for indirect vision** which are attached to the same mounting as Class IV ~~mirrors~~ **devices for indirect vision**.

6.3.3.2. **In case of mirrors**, should the mounting of the mirror break during the tests described in paragraph 6.3.2. for mirrors stuck to the windscreen, the part remaining must not project beyond the base by more than 10 mm and the configuration remaining after the test must satisfy the conditions laid down in paragraph 6.1.1.3.

6.3.3.3. In case of mirrors, the reflecting surface must not break during the tests described in paragraph 6.3.2. However, breakage of the reflecting surface will be allowed if one of the following conditions is fulfilled:

6.3.3.3.1. The fragments of glass still adhere to the back of the housing or to a surface firmly attached to the housing; partial separation of the glass from its backing is admissible provided that this does not exceed 2.5 mm on either side of the cracks. It is permissible for small splinters to become detached from the surface of the glass at the point of impact;

6.3.3.3.2. The reflecting surface is made of safety glass.

6.3.3.4. In case of camera-monitor-systems, the lens shall not break during the test described in paragraph 6.3.2.

7. Modification of the type of device for indirect vision and extension of approval

7.1. Every modification to an existing type of device for indirect vision including its connection to the bodywork shall be notified to the Type Approval Authority which approved the type of device for indirect vision. The Type Approval Authority shall then either:

- (a) Decide, in consultation with the manufacturer, that a new type-approval is to be granted, or
- (b) Apply the procedure contained in paragraph 7.1.1. (Revision) and, if applicable, the procedure contained in paragraph 7.1.2. (Extension).

7.1.1. Revision

When particulars recorded in the information folder have changed and the Type Approval Authority considers that the modifications made are unlikely to have an appreciable adverse effect and that in any case the device for indirect vision still complies with the requirements, the modification shall be designated a "revision".

In such a case, the Type Approval Authority shall issue the revised pages of the information folder as necessary, marking each revised page to show clearly the nature of the modification and the date of re-issue. A consolidated, updated version of the information folder, accompanied by a detailed description of the modification, shall be deemed to meet this requirement.

7.1.2. Extension

The modification shall be designated an "extension" if, in addition to the change of the particulars recorded in the information folder,

- (a) Further inspections or tests are required, or
- (b) Any information on the communication document (with the exception of its attachments) has changed, or
- (c) Approval to a later series of amendments is requested after its entry into force.

7.2. Confirmation or refusal of approval, specifying the alterations shall be communicated by the procedure specified in paragraph 5.3. above to the Parties to the Agreement which apply this Regulation. In addition, the index to the information package, attached to the communication document, shall be amended accordingly to show the date of the most recent revision or extension.

7.3. (Reserved)

7.4. The Type Approval Authority issuing the extension of approval shall assign a series number to each communication form drawn up for such an extension.

8. Conformity of production

-
- 8.1. The conformity of production procedure shall comply with those set out in the Agreement, Appendix 2 (E/ECE/324-E/ECE/TRANS/505/Rev.2).
- 8.2. Every device for indirect vision approved under this Regulation shall be so manufactured as to conform to the type approved by meeting the requirements set out in paragraph 6. above.

9. Penalties for non-conformity of production

- 9.1. The approval granted in respect of a type of device for indirect vision pursuant to this Regulation may be withdrawn if the requirement laid down in paragraph 8.1. above is not complied with or if the type of device for indirect vision did not satisfy the requirements prescribed in paragraph 8.2. above.
- 9.2. If a Party to the Agreement which applies this Regulation withdraws an approval it has previously granted, it shall forthwith so notify the other Contracting Parties applying this Regulation by means of a copy of the communication form bearing at the end, in large letters, the signed and dated annotation "APPROVAL WITHDRAWN".

10. Production definitively discontinued

If the holder of the approval completely ceases to manufacture a type of device for indirect vision approved in accordance with this Regulation, he shall so inform the authority which granted the approval. Upon receiving the relevant communication that authority shall inform thereof the other Parties to the Agreement applying this Regulation by means of a copy of the approval form bearing at the end, in large letters, the signed and dated annotation "PRODUCTION DISCONTINUED".

11. Names and addresses of Technical Services responsible for conducting approval tests, and of Type Approval Authorities

The Parties to the Agreement applying this Regulation shall communicate to the United Nations Secretariat the names and addresses of the Technical Services responsible for conducting approval tests and of the Type Approval Authorities which grant approval and to which forms certifying approval or refusal or extension or withdrawal of approval, issued in other countries, are to be sent.

I. INSTALLATION OF DEVICES FOR INDIRECT VISION

12. Definitions

For the purpose of this Regulation:

- 12.1. "*The driver's ocular points*" means two points 65 mm apart and 635 mm vertically above point R of the driver's seat as defined in Annex 8. The straight line joining these points runs perpendicular to the vertical longitudinal median plane of the vehicle. The centre of the segment joining the two ocular points is in a vertical longitudinal plane which must pass through the centre of the driver's designated seating position, as specified by the vehicle manufacturer.
- 12.2. "*Ambinocular vision*" means the total field of vision obtained by the superimposition of the monocular fields of the right eye and the left eye (see Figure 3 below).

Figure 3

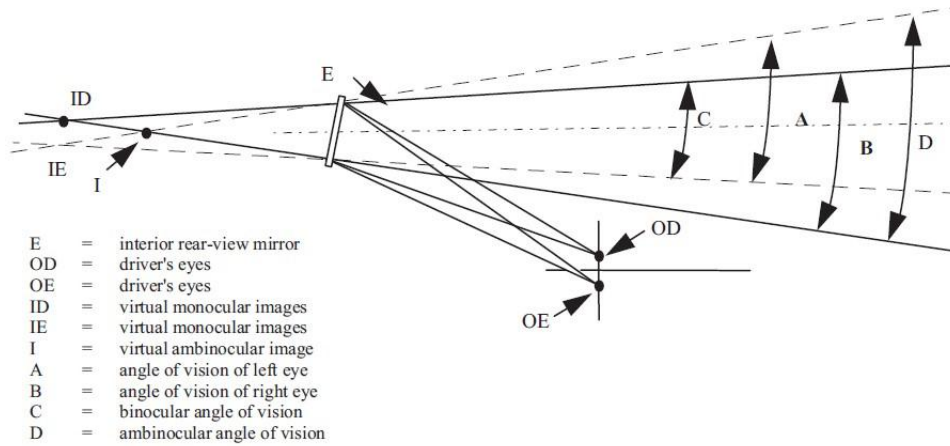

12.3. "Type of vehicle as regards indirect vision" means motor vehicles which are identical in respect of the following basic features:

- 12.3.1. Type of device for indirect vision;
 - 12.3.2. The bodywork features which reduce the field of vision;
 - 12.3.3. The coordinates of point R (where applicable);
 - 12.3.4. The prescribed positions, and type-approval markings of compulsory and (if fitted) optional devices for indirect vision.
- 12.4. "Vehicles of categories L₂, L₅, M₁, M₂, M₃, N₁, N₂ and N₃" mean those defined in the Consolidated Resolution on the Construction of Vehicles (R.E.3), (document TRANS/WP.29/78/Rev.2, para.2).
- 12.5. "Forward control" means a configuration in which more than half of the engine length is rearward of the foremost point of the windshield base and the steering wheel hub in the forward quarter of the vehicle length.

13. Application for approval

- 13.1. The application for approval of a vehicle type with regard to the installation of devices for indirect vision shall be submitted by the vehicle manufacturer or by his duly accredited representative.
- 13.2. A model of information document is shown in Annex 2.
- 13.3. A vehicle representative of the vehicle type to be approved shall be submitted to the Technical Service responsible for conducting the approval tests.
- 13.4. The Competent Authority shall verify the existence of satisfactory arrangements for ensuring effective checks on conformity of production before type-approval is granted.

14. Approval

- 14.1. If the vehicle type submitted for approval in accordance with paragraph 13. above meets the requirements of paragraph 15. of this Regulation, approval shall be granted.
- 14.2. An approval number shall be assigned to each type approved. Its first two digits (at present 02) shall indicate the series of amendments incorporating the most recent or technical amendments made to the Regulation at the time of issue of the approval. The same Contracting Party shall not assign the same number to another vehicle type.
- 14.3. Notice of approval or of refusal or of extension or withdrawal of approval of a vehicle type pursuant to this Regulation shall be communicated to the Parties to the Agreement which apply this Regulation by means of a form conforming to the model in Annex 4 to this Regulation.

15. Requirements

- 15.1. General
- 15.1.1. The compulsory and optional devices for indirect vision, set out in the table under paragraph 15.2.1.1.1., installed on the vehicle shall be of a type approved under this Regulation.
- 15.1.2. ~~Mirrors and other~~ Devices for indirect vision must be fitted in such a way ~~that the mirror or other device does not~~ **the devices do not** move so as significantly to change the field of vision as measured or vibrate to an extent which would cause the driver to misinterpret the nature of the image perceived.
- 15.1.3. The conditions laid down in paragraph 15.1.2. must be maintained when the vehicle is moving at speeds of up to 80 per cent of its maximum design speed, but not exceeding 150 km/h.
- 15.1.4. The fields of vision defined below shall be established using ambinocular vision, the eyes being at the "driver's ocular points" as defined in paragraph 12.1. The fields of vision shall be determined when the vehicle is in running order as defined in the consolidated Resolution on the Construction of vehicles (RE.3) (ECE/TRANS/WP.29/78/Rev.2, para. 2.2.5.4.), plus for M₁ and N₁ vehicles one front seat passenger (75 kg). When established through windows, the glazing shall have a total light transmission factor in accordance with Regulation No. 43, Annex 21.
- 15.2. ~~Mirrors~~ **Devices for indirect vision"**
- 15.2.1. Number
- 15.2.1.1. Minimum number of compulsory mirrors **devices for indirect vision."**

15.2.1.1.1. The fields of vision prescribed in paragraph 15.2.4. shall be obtained from the minimum number ~~or~~ **of mandatory mirrors or camera monitor devices** set out in the following table. ~~Where the presence of a mirror is not requested on a mandatory base, this means that no other system for indirect vision can be requested on a mandatory base.~~

In case of camera-monitor systems, there is no minimum number but they shall provide the same field of vision as given in this table and the provision on the minimum mounting height does not apply.

In case of camera-monitor devices the maximum number of monitors shall not exceed the corresponding number of mirrors."

Vehicle category	Interior mirror	Exterior mirrors				
	Interior mirror Central rear view Class I	Main mirror (large) rear view Class II	Main mirror (small) rear view Class III	Wide-angle mirror view Class IV	Close-proximity mirror view Class V	Front mirror view Class VI
M ₁	Compulsory Unless the vehicle is fitted with anything other than safety glazing material in the field of vision prescribed in paragraph 15.2.4.1.	Optional	Compulsory 1 on the driver's side and 1 on the passenger's side Class II mirrors may be fitted as an alternative.	Optional 1 on the driver's side and / or 1 on the passenger's side	Optional 1 on the driver's side and 1 on the passenger's side (both must be fitted at least 2 m above the ground)	Optional (shall be fitted at least 2 m above the ground)
M ₂	Optional (no requirements for the field of view)	Compulsory 1 on the driver's side and 1 on the passenger's side	Not permitted	Optional 1 on the driver's side and / or 1 on the passenger's side	Optional 1 on the driver's side and 1 on the passenger's side (both must be fitted at least 2 m above the ground)	Optional (shall be fitted at least 2 m above the ground)
M ₃	Optional (no requirements for the field of view)	Compulsory 1 on the driver's side and 1 on the passenger's side	Not permitted	Optional 1 on the driver's side and / or 1 on the passenger's side	Optional 1 on the driver's side and 1 on the passenger's side (both must be fitted at least 2 m above the ground)	Optional (shall be fitted at least 2 m above the ground)
N ₁	Compulsory Unless the vehicle is fitted with anything other than safety glazing material in the field of vision prescribed in paragraph 15.2.4.1.)	Optional	Compulsory 1 on the driver's side and 1 on the passenger's side Class II mirrors may be fitted as an alternative.	Optional 1 on the driver's side and / or 1 on the passenger's side	Optional 1 on the driver's side and 1 on the passenger's side (both must be fitted at least 2 m above the ground)	Optional (shall be fitted at least 2 m above the ground)

Vehicle category	Interior mirror	Exterior mirrors				
	Interior mirror Central rear view Class I	Main mirror (large) rear view Class II	Main mirror (small) rear view Class III	Wide-angle mirror view Class IV	Close-proximity mirror view Class V	Front mirror view Class VI
N ₂ □□7,5 t	Optional (no requirements for the field of view)	Compulsory 1 on the driver's side and 1 on the passenger's side	Not permitted	Compulsory For both sides if a Class V mirror device can be fitted Optional For both sides together if not	In addition according to paragraphs 15.2.4.5.6 to 15.2.4.5.11 for vehicles with a mounting height of the Class V mirror of not less than 2.4 m (see paragraph 15.2.4.5.12): the required field of vision (paragraphs 15.2.4.5.6 to 15.2.4.5.9) may be viewed using a combination of direct view and indirect vision devices (of Class IV, V, VI).	Optional 1 front mirror (shall be fitted at least 2 m above the ground)
N ₂ > 7,5 t	Optional (no requirements for the field of view)	Compulsory 1 on the driver's side and 1 on the passenger's side	Not permitted	Compulsory 1 on the driver's side and 1 on the passenger's side	In addition according to paragraphs 15.2.4.5.6 to 15.2.4.5.11 for vehicles with a mounting height of the Class V mirror of not less than 2.4 m (see paragraph 15.2.4.5.12): the required field of vision (paragraphs 15.2.4.5.6 to 15.2.4.5.9) may be viewed using a combination of direct view and indirect vision devices (of Class IV, V, VI).	Compulsory , (see paragraph 15.2.1.1.2 1. front mirror (shall be fitted at least 2 m above the ground)
N ₃	Optional (no requirements for the field of view)	Compulsory 1 on the driver's side and 1 on the passenger's side	Not permitted	Compulsory 1 on the driver's side and 1 on the passenger's side	In addition according to paragraphs 15.2.4.5.6 to 15.2.4.5.11 for vehicles with a mounting height of the Class V mirror of not less than 2.4 m (see paragraph 15.2.4.5.12): the required field of vision (paragraphs 15.2.4.5.6 to 15.2.4.5.9) may be viewed using a combination of direct view and indirect vision devices (of Class IV, V, VI).	Compulsory , (see paragraph 15.2.1.1.2 1. front mirror (shall be fitted at least 2 m above the ground)

~~15.2.1.1.2. In case the described field of vision of a front mirror prescribed in paragraph 15.2.4.6. and/or a close proximity mirror described in paragraph 15.2.4.5. can be obtained by another device for indirect vision that is approved according to paragraph 6.2. and that is installed according to paragraph 15., this device can be used instead of the relevant mirror or mirrors.~~

In case a camera/monitor device is used, the monitor must exclusively show:

- ~~(a) The field of vision prescribed in paragraph 15.2.4.5. when the close proximity mirror has been substituted;~~
- ~~(b) The field of vision prescribed in paragraph 15.2.4.6. when the front mirror has been substituted while the vehicle is moving forward with a speed of up to 10 km/h; or~~
- ~~(c) Simultaneously the fields of vision prescribed in paragraphs 15.2.4.5. and 15.2.4.6. when the close proximity mirror and the front mirror have been substituted. In the case where the vehicle is moving forward at a higher speed than 10 km/h or moving backwards, the monitor may be used for other information, provided that the field of vision prescribed in paragraph 15.2.4.5. is permanently displayed.~~

15.2.1.1.2 **In case a camera-monitor device is used for rendering the field(s) of vision, the relevant field(s) of vision shall be permanently visible to the driver when the ignition is on. However, when the vehicle is moving forward at a speed higher than 10 km/h or rearwards, the monitor or the part of the monitor intended for rendering the Class VI field of vision may be used for other information. Multiple images may be used or displayed provided that the monitor has been approved in this mode.**

Additional vehicle information may be displayed provided that this does not compromise the required field(s) of vision."

15.2.1.1.3. ~~Rear view mirrors~~ **Mirrors and camera monitor devices** required for L-category vehicles with body work

<i>Category of vehicle</i>	Interior mirror Central rear-view (Class I)	Main rear-view exterior mirror(s) (Classes III and VII)
L category motor vehicles fitted with bodywork which partly or wholly encloses the driver	1 ¹	1, if there is an interior mirror; a central rear-view device for indirect vision; 2, if there is not an interior mirror a central rear-view device for indirect vision
¹ No interior rear-view mirror central rear-view device for indirect vision is required if the visibility conditions referred to in paragraph 15.2.5.4.1. below cannot be met. In this case two exterior rear-view mirrors or camera monitor devices are required, one giving the view on the left and one giving the view on the right hand side of the vehicle.		

Where a single exterior rear view mirror **or camera** is fitted this shall be located on the left hand side of the vehicle in those countries where the traffic

drives on the right and on the right hand side of the vehicle in those countries where the traffic drives on the left.

Multiple images may be used or displayed provided that the monitor has been approved in this mode.

15.2.1.1.4. Optional ~~rear-view mirrors~~ for L-category vehicles

The fitting of an exterior rear-view mirror **or camera monitor device giving the view** on the side of the vehicle opposite to that of the mandatory rear-view **device for indirect vision** ~~mirror~~ referred to in paragraph 15.2.1.1.3, is permissible. The rear-view mirror shall meet the requirements of this Regulation. **The rear-view mirror shall meet the requirements of this Regulation.**

15.2.1.2. The provisions of this Regulation do not apply to the surveillance mirrors defined in paragraph 2.1.1.3. **or surveillance camera-monitor recording device defined in paragraph 2.3.** Nevertheless, the exterior surveillance mirrors must be mounted at least 2 m above the ground when the vehicle is under a load corresponding to its maximum technical permissible mass.

15.2.2. Position

15.2.2.1. ~~Mirrors~~ **Devices for indirect vision must shall** be so placed that the driver, when sitting on the driving seat in a normal driving position, has a clear view of the road to the rear, side(s) or front of the vehicle.

15.2.2.2. Exterior mirrors shall be visible through the side windows or through the portion of the windscreen that is swept by the windscreen wiper. Nevertheless, for design reasons, this last provision (i.e. the provisions relating the cleaned part of the windscreen) shall not apply to:

- (a) Exterior mirrors on the passenger side and optional exterior mirrors on the driver side of vehicles of categories M₂ and M₃;
- (b) Class VI mirrors.

15.2.2.3. In the case of any vehicle, which is in chassis/cab form when the field of vision is measured, the minimum and maximum body widths shall be stated by the manufacturer and, if necessary, simulated by dummy headboards. All vehicles and ~~mir-~~ **devices for indirect vision** configurations taken into consideration during the tests shall be shown on the type-approval certificate for a vehicle with regard to the installation of ~~mirrors~~ **devices for indirect vision** (see Annex 4).

15.2.2.4. The prescribed exterior mirror on the driver's side of the vehicle must be so located that an angle of not more than 55° is formed between the vertical longitudinal median plane of the vehicle and the vertical plane passing through the centre of the mirror and through the centre of the straight line 65 mm long which joins the driver's two ocular points.

15.2.2.5. ~~Mirrors must~~ **Devices for indirect vision shall** not project beyond the external bodywork of the vehicle substantially more than is necessary to comply with the requirements concerning fields of vision laid down in paragraph 15.2.4.

15.2.2.6. Where the lower edge of an exterior mirror is less than 2 m above the ground when the vehicle is loaded to its technically permissible maximum laden mass, this mirror must not project more than 250 mm beyond the overall width of the vehicle measured without mirrors.

15.2.2.7. Class V and Class VI mirrors shall be mounted on vehicles in such a way that, regardless of their position after adjustment, no part of these mirrors or their holders is less than 2 m from the ground when the vehicle is under a load corresponding to its technically permissible maximum laden mass.

These mirrors shall not, however, be mounted on vehicles the cab height of which is such as to prevent compliance with this requirement. In this case ~~another device for indirect vision is not requested.~~ **another device for indirect vision is not mandatory.**

15.2.2.8. Subject to the requirements of paragraphs 15.2.2.5., 15.2.2.6. and 15.2.2.7., ~~mirrors~~ **device for indirect vision** may project beyond the permissible maximum widths of vehicles.

15.2.2.9. All Class VII mirrors shall be attached in such a way that they remain in a stable position under normal vehicle driving conditions.

15.2.3. Adjustment

15.2.3.1. ~~The interior mirror must~~ **If a Class I mirror is fitted it** shall be capable of being adjusted by the driver from his driving position.

15.2.3.2. ~~The exterior mirror situated on the driver's side~~ **If a Class II or Class III mirror is fitted on the driver side, it shall** must be capable of being adjusted from inside the vehicle while the door is closed, although the window may be open. The mirror may, however, be locked in position from the outside.

15.2.3.3. The requirements of paragraph 15.2.3.2. do not apply to exterior mirrors which, after having been knocked out of alignment, can be returned to their former position without the need for adjustment.

15.2.4. Fields of vision

15.2.4.1. ~~Interior rear-view mirror~~ **Central rear-view field of vision (Class I)**

The field of vision must be such that the driver can see at least a 20 m wide, flat, horizontal portion of the road centred on the vertical longitudinal median plane of the vehicle and extending from 60 m behind the driver's ocular points (Figure 4) to the horizon.

Figure 4

Field of vision of Class I mirror Class I field of vision

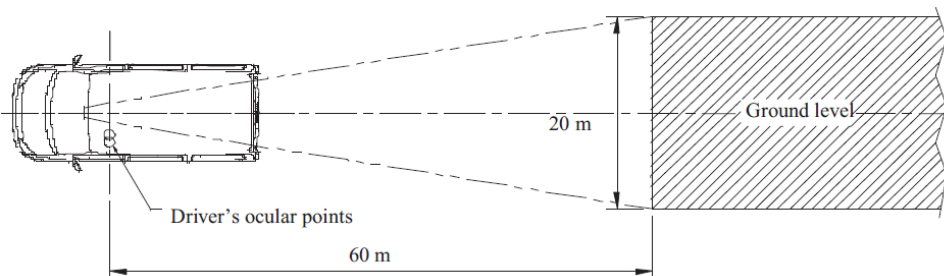

15.2.4.2. ~~Main exterior rear-view mirrors~~ **Class II field of vision**

15.2.4.2.1. ~~Exterior Main rear-view mirror~~ **field of vision** on the driver's side

The field of vision must be such that the driver can see at least a 5 m wide, flat, horizontal portion of the road, which is bounded by a plane which is parallel to the median longitudinal vertical plane and passing through the outermost point of the vehicle on the driver's side of the vehicle and extends from 30 m behind the driver's ocular points to the horizon.

In addition, the road must be visible to the driver over a width of 1 m, which is bounded by a plane parallel to the median longitudinal vertical plane and passing through the outermost point of the vehicle starting from a point 4 m behind the vertical plane passing through the driver's ocular points (see Figure 5).

15.2.4.2.2. ~~Exterior Main rear-view mirror~~ **field of vision** on the passenger's side

The field of vision must be such that the driver can see at least a 5 m wide, flat, horizontal portion of the road, which is bounded on the passenger's side by a plane parallel to the median longitudinal vertical plane of the vehicle and passing through the outermost point of the vehicle on the passenger's side and which extends from 30 m behind the driver's ocular points to the horizon.

In addition, the road must be visible to the driver over a width of 1 m, which is bounded by a plane parallel to the median longitudinal vertical plane and passing through the outermost point of the vehicle starting from a point 4 m behind the vertical plane passing through the driver's ocular points (see Figure 5).

Figure 5

Field of vision of Class II mirrors
Class II field of vision

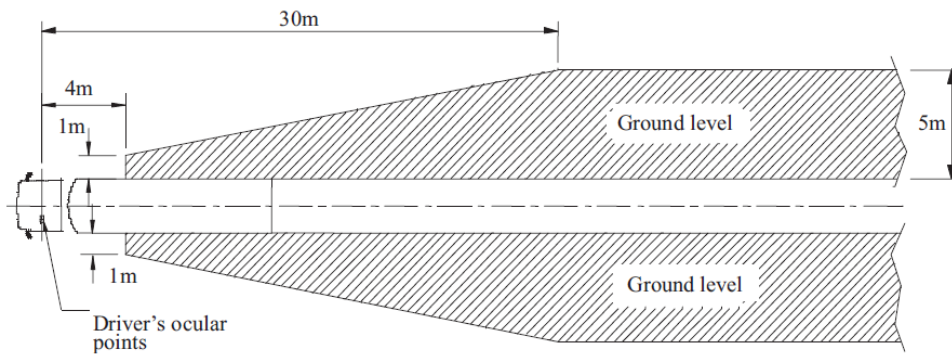

15.2.4.3. ~~Main exterior rear-view mirrors~~ **Class III Class III field of vision**

15.2.4.3.1. ~~Exterior Main rear-view mirror~~ **field of vision** on the driver's side

The field of vision must be such that the driver can see at least a 4 m wide, flat, horizontal portion of the road, which is bounded by a plane parallel to the median longitudinal vertical plane and passing through the outermost point of the vehicle on the driver's side of the vehicle and extends from 20 m behind the driver's ocular points to the horizon.

lar points to the horizon (see Figure 6).

In addition, the road must be visible to the driver over a width of 1 m, which is bounded by a plane parallel to the median longitudinal vertical plane and passing through the outermost point of the vehicle starting from a point 4 m behind the vertical plane passing through the driver's ocular points.

15.2.4.3.2. ~~Exterior~~ Main rear-view mirror field of vision on the passenger's side

The field of vision must be such that the driver can see at least a 4 m wide flat, horizontal portion of the road which is bounded by a plane parallel to the median longitudinal vertical plane passing through the outermost point of the vehicle on the passenger's side and which extends from 20 m behind the driver's ocular points to the horizon (see Figure 6).

In addition, the road must be visible to the driver over a width of 1 m, which is bounded by a plane parallel to the median longitudinal vertical plane and passing through the outermost point of the vehicle starting from a point 4 m behind the vertical plane passing through the driver's ocular points.

Figure 6

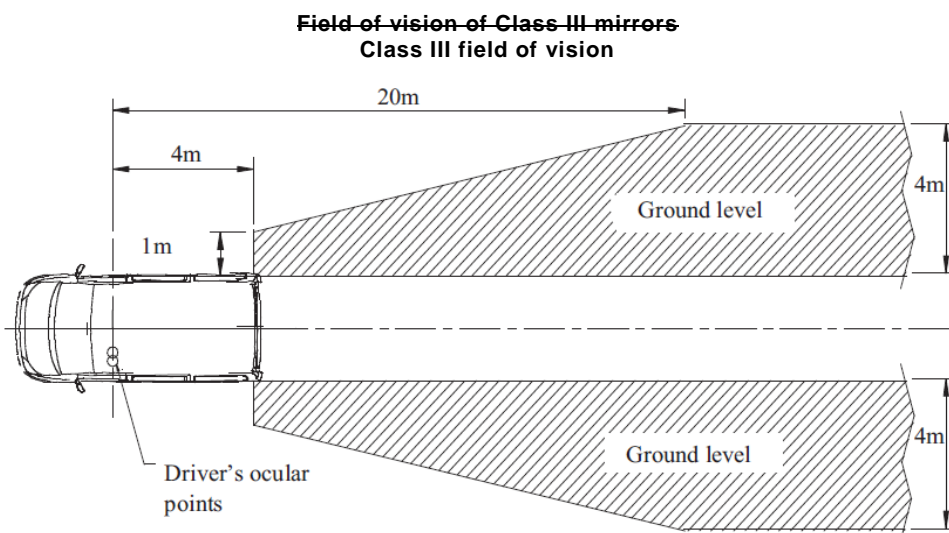

15.2.4.4. ~~“Wide-angle” exterior mirror (Class IV)~~ Class IV field of vision

15.2.4.4.1. ~~“Wide-angle” exterior mirror~~ Field of vision on the driver's side

The field of vision must be such that the driver can see at least a 15 m wide, flat, horizontal portion of the road, which is bounded by a plane parallel to the median longitudinal vertical plane of the vehicle and passing through the outermost point of the vehicle on the driver's side and which extends from at least 10 m to 25 m behind the driver's ocular points.

In addition, the road must be visible to the driver over a width of 4.5 m, which is bounded by a plane parallel to the median longitudinal vertical plane and passing through the outermost point of the vehicle starting from a point 1.5 m behind the

vertical plane passing through the driver's ocular points (see Figure 7).

15.2.4.4.2. ~~“Wide-angle” exterior mirror~~ **Field of vision** on the passenger's side

The field of vision must be such that the driver can see at least a 15 m wide, flat, horizontal portion of the road, which is bounded by a plane parallel to the median longitudinal vertical plane of the vehicle and passing through the outermost point of the vehicle on the passenger's side and which extends from at least 10 m to 25 m behind the driver's ocular points.

In addition, the road must be visible to the driver over a width of 4.5 m, which is bounded by a plane parallel to the median longitudinal vertical plane and passing through the outermost point of the vehicle starting from a point 1.5 m behind the vertical plane passing through the driver's ocular points (see Figure 7).

Figure 7

~~Field of vision of Class IV wide-angle mirrors~~
Class IV field of vision

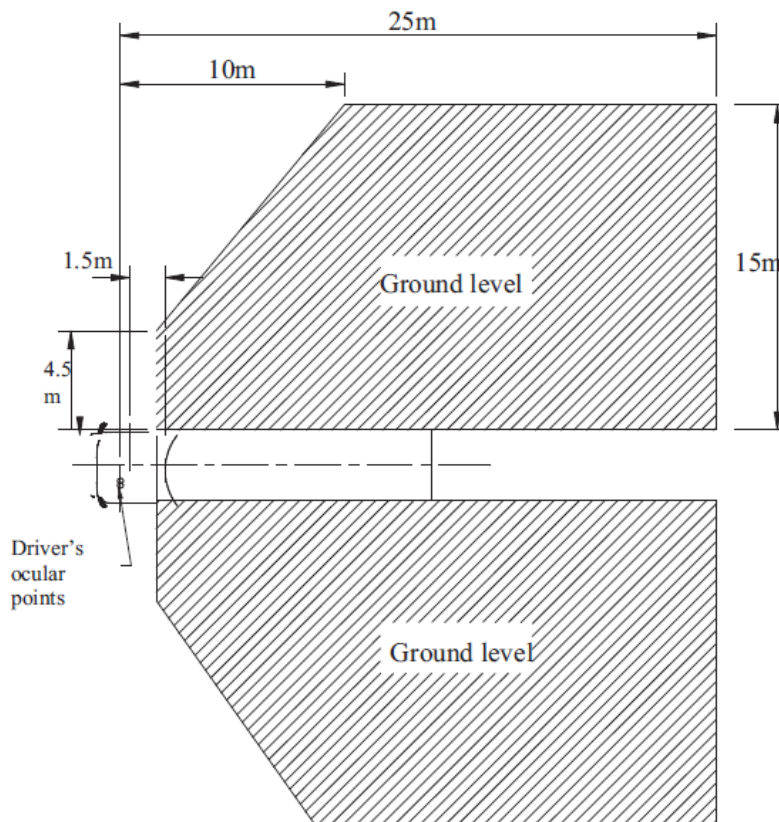

15.2.4.4.5. ~~“Close-proximity” exterior mirror (Class V)~~ **Class V field of vision**

The field of vision must be such that the driver can see a flat horizontal portion of

the road along the side of the vehicle, bounded by the following vertical planes (see Figures 8a and 8b):

- 15.2.4.5.1. The plane parallel to the median longitudinal vertical plane of the vehicle which passes through the outermost point of the vehicle cab on the passenger's side;
- 15.2.4.5.2. In the transverse direction, the parallel plane passing at a distance of 2 m in front of the plane mentioned in paragraph 15.2.4.5.1.
- 15.2.4.5.3. To the rear, the plane parallel to the vertical plane passing through the driver's ocular points and situated at a distance of 1.75 m behind that plane;
- 15.2.4.5.4. To the front, the plane parallel to the vertical plane passing through the driver's ocular points and situated at a distance of 1 m in front of that plane. If the vertical transverse plane passing through the leading edge of the vehicle bumper is less

than 1 m in front of the vertical plane passing through the driver's ocular points, the field of vision shall be limited to that plane.

- 15.2.4.5.5. In case the field of vision described in Figures 8a and 8b can be perceived through the combination of the field of vision from a Class IV **device for indirect vision wide-angle mirror** and that of a Class VI **device for indirect vision front mirror**, the installation of a Class V ~~close proximity mirror~~ **device for indirect vision** is not compulsory.

Figures 8a and 8b

Field of vision of Class V close-proximity mirror
Class V field of vision

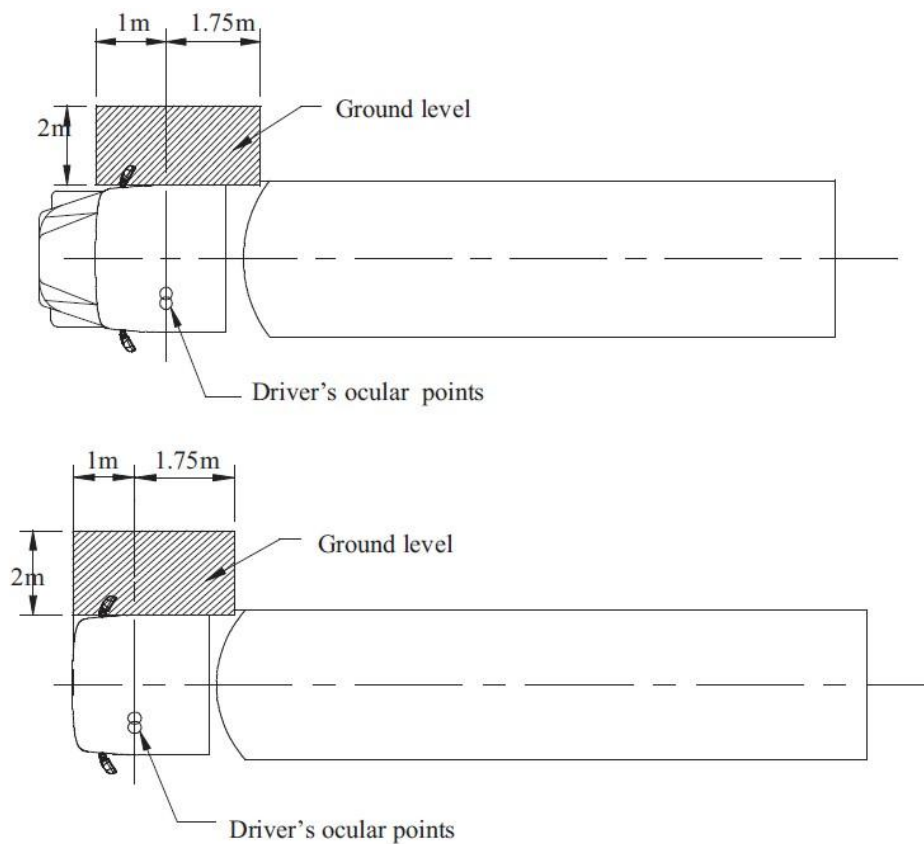

- 15.2.4.5.6. On the passenger side only, the field of vision shall also be such that the driver can see a flat horizontal portion of the road along the side of the vehicle which is outside the field defined in paragraphs 15.2.4.5.1. to 15.2.4.5.4. but within the field bounded by the following vertical planes; the front of this field of vision may be rounded off with a radius of 2,000 mm (see Figures 8c and 8d):

- 15.2.4.5.7. In the transverse direction, the parallel plane passing at a distance of 4.5 m in front of the plane mentioned in paragraph 15.2.4.5.1.

-
- 15.2.4.5.8. To the rear, the plane parallel to the vertical plane passing through the driver's ocular points and situated at a distance of 1.75 m behind that plane.
- 15.2.4.5.9. to the front, the plane parallel to the vertical plane passing through the driver's ocular points and situated at a distance of 3 m in front of that plane. This field of vision may be partially provided by a front-**view device** mirror (Class VI).
- 15.2.4.5.10. The field of vision prescribed in paragraphs 15.2.4.5.6. to 15.2.4.5.9. may be partially provided by a 'wide-angle' exterior mirror **wide-angle view device** (Class IV) or a combination of a close-proximity **view device** exterior mirror (Class V) and a front-**view device** mirror (Class VI).
- 15.2.4.5.11. The area prescribed in paragraphs 15.2.4.5.6. to 15.2.4.5.9. may be viewed using a combination of direct view and indirect vision devices.
- 15.2.4.5.12. Paragraphs 15.2.4.5.6. to 15.2.4.5.9 shall not apply to a vehicle where no part of the **device for indirect vision mirror**, or its holder, is less than 2.4 m above the ground, regardless of its position after adjustment.
- 15.2.4.5.13. Paragraphs 15.2.4.5.6. to 15.2.4.5.9. shall not apply to a vehicle of category M₂ or M₃.

Figures 8c and 8d

Larger field of vision on the passenger side

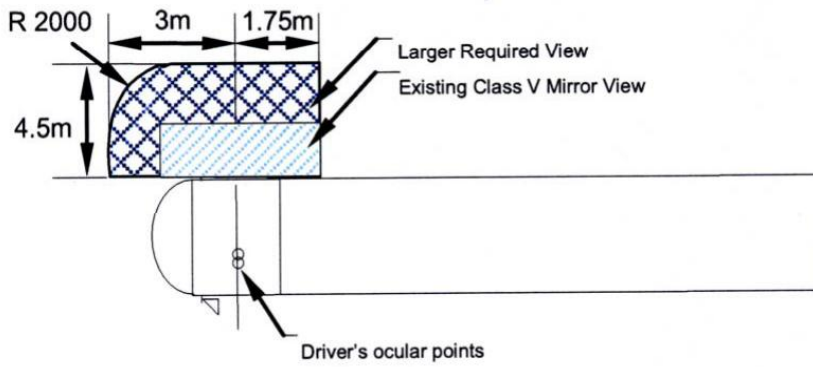
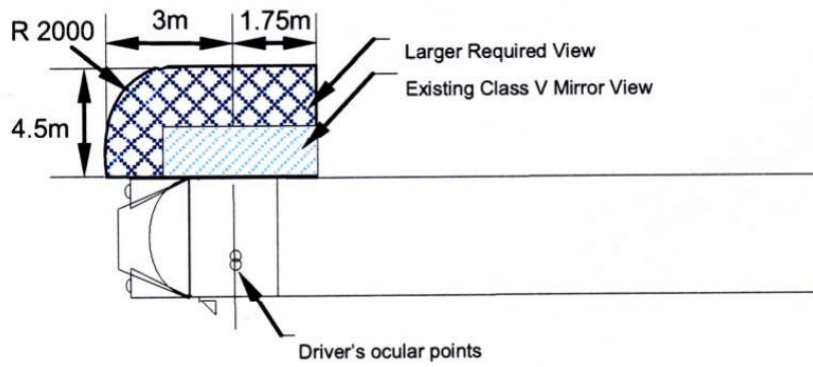

15.2.4.6. ~~Front mirror (Class VI)~~ **Device for indirect vision of Class VI**

15.2.4.6.1. The field of vision shall be such that the driver can see at least a flat horizontal portion of the road, which is bounded by:

- (a) A transverse vertical plane through the outermost point of the front of the vehicle;
- (b) A transverse vertical plane 2,000 mm in front of the plane defined in (a),
- (c) A longitudinal vertical plane parallel to the longitudinal vertical median plane going through the outermost side of the vehicle at the driver's side and;
- (d) A longitudinal vertical plane parallel to the longitudinal vertical median plane 2 000 mm outside the outermost side of the vehicle opposite to the driver's side.

The front of this field of vision opposite to the driver's side may be rounded off with a radius of 2 000 mm (see Figure 9).

For the defined field of vision, see also paragraph 15.2.4.9.2.

The provisions for ~~front mirrors~~ **Class VI devices for indirect vision** are compulsory for forward controlled (as defined in paragraph 12.5.) vehicles of categories $N_2 > 7.5$ t and N_3 .

If vehicles of these categories cannot fulfil the requirements by using a front ~~mirror or a camera/monitor device~~ **a device for indirect vision**, a vision support system shall be used. In the case of a vision support system this device must be able to detect an object of 50 height and with a diameter of 30 cm within the field defined in Figure 9.

Figure 9

~~Field of vision of Class VI front mirror~~
Class VI field of vision

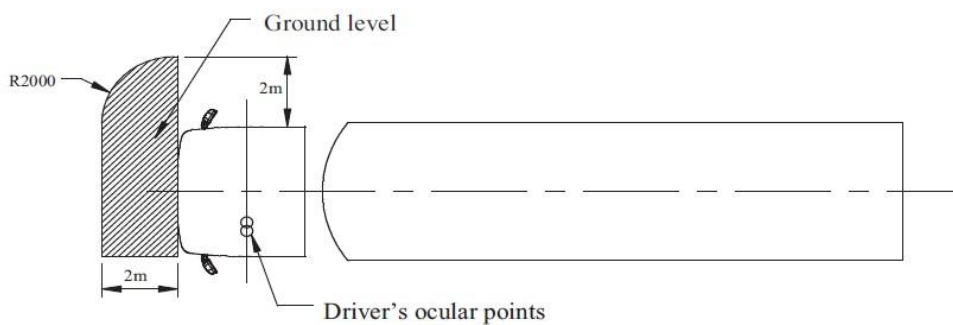

15.2.4.6.2. However, if the driver can see, taking into account the obstructions by the A-pillars, a straight line 300 mm in front of the vehicle at a height of 1,200 mm above the road surface and which is situated between a longitudinal vertical plane parallel to the longitudinal vertical median plane going through the outermost side of the vehicle at the driver's side and a longitudinal vertical plane parallel to the longitudinal vertical median plane 900 mm outside the outermost side of the vehicle opposite to the driver's side, a ~~front mirror of Class VI~~ **Class VI device for indirect vision** is not mandatory.

15.2.4.6.3. For the purpose of paragraphs 15.2.4.6.1. and 15.2.4.6.2. parts permanently attached to the vehicle that are situated both above the driver's eye points and in front of the transverse vertical plane passing through the foremost surface of the vehicle's front bumper shall not be taken into account when defining the front of the vehicle.

15.2.4.7. ~~L-category mirror (Class VII)~~ **Class VII field of vision**

15.2.4.7.1. ~~Exterior Field of vision rear-view mirror~~ on the driver's side

The field of vision must be such that the driver can see at least a 2.50 m wide, flat, horizontal portion of the road, which is bounded by a plane parallel to the median longitudinal vertical plane and passing through the outermost point of the vehicle on the driver's side of the vehicle and extends from 10 m behind the driver's ocular points to the horizon (see Figure 10).

15.2.4.7.2. ~~Exterior rear-view mirror~~ **Field of vision** on the passenger's side

The field of vision must be such that the driver can see at least a 4 m wide flat, horizontal portion of the road which is bounded by a plane parallel to the median longitudinal vertical plane passing through the outermost point of the vehicle on the passenger's side and which extends from 20 m behind the driver's ocular points to the horizon (see Figure 10).

Figure 10

Field of vision of Class VII mirrors
Class VII field of vision mirrors

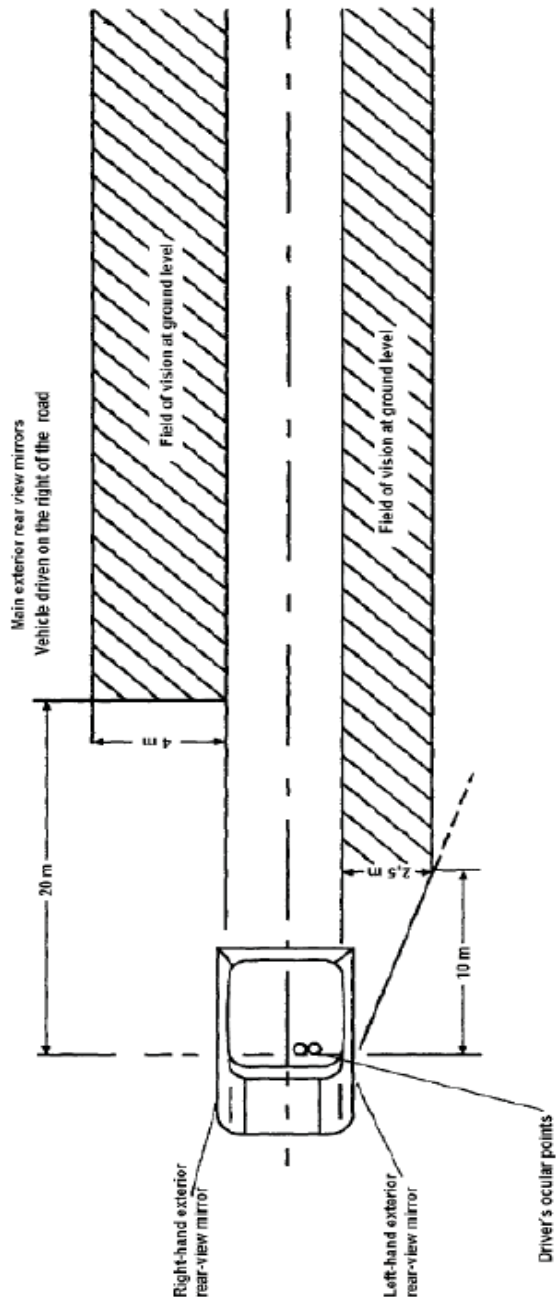

15.2.4.8. In the case of mirrors consisting of several reflecting surfaces which are either of different curvature or make an angle with each other, at least one of the reflecting surfaces must provide the field of vision and have the dimensions (paragraph 6.1.2.1.2.2.) specified for the class to which they belong.

15.2.4.9. Obstructions

15.2.4.9.1. Interior-mounted Class I rear-view devices ~~mirror (Class I)~~

The field of vision may be reduced by the presence of devices such as sun visors, windscreen wipers, heating elements and stop lamp of category S3, provided that all these devices together do not obscure more than 15 per cent of the prescribed field of vision. Headrests or framework or bodywork such as window columns of rear split doors, rear window frame shall be excluded from the calculation. This requirement shall be tested by projection on to a vertical plane at right angles to the longitudinal centreplane of the vehicle. The degree of obstruction shall be measured with the sun visors folded back.

15.2.4.9.2. Exterior mounted devices for indirect vision ~~mirrors~~ (Classes II, III, IV, V, and VI and VII)

In the fields of vision specified above, obstruction due to the bodywork and its components, such as other cab ~~mirrors,~~ devices for indirect vision door handles, outline marker lights, direction indicators and front and rear bumpers, as well as reflective-surface cleaning components, shall not be taken into account if they are responsible for a total obstruction of less than 10 per cent of the specified field of vision. In the case of a vehicle designed and constructed for special purposes where, due to its special features, it is not possible to meet this requirement, the obstruction of the required field of vision of a Class VI mirror caused by the special features may be more than 10 per cent but not more than necessary for its special function.

15.2.4.10. Test procedure

The field of vision shall be determined by placing powerful light sources at the ocular points and examining the light reflected on the vertical monitoring screen. Other equivalent methods may be used.

15.3. Devices for indirect vision other than mirrors

15.3.1. A device for indirect vision shall give such performances that a critical object can be observed by the driver over the entire required field of vision, taking into account the critical perception according the procedure of Annex 10.

Alternatively, the determination of the displayed object size shall be performed according to Annex 11.

For camera monitor devices of classes I to IV [and VII] the requirements of Annex xx shall be fulfilled.

15.3.2. Obstruction of the driver's direct view caused by the installation of a device for indirect vision shall be restricted to a minimum.

15.3.3. (Reserved)

15.3.4. Installation requirements for the monitor

~~The viewing direction of the monitor shall roughly be the same direction as the one for the main mirror.~~ **Monitor(s) shall be located in an ergonomically favourable**

position."

- 15.3.5. Vehicles may be equipped with additional devices for indirect vision.
- 15.3.6. The provisions of this Regulation do not apply to the surveillance camera-monitor-recording devices defined in paragraph 2.1.2.13. Exterior surveillance cameras either shall be mounted at least 2 m above the ground when the vehicle is under a load corresponding to its maximum technical permissible mass, or, if their lower edge is less than 2 m from the ground, shall not project more than 50 mm beyond the overall width of the vehicle measured without this device and have a radii of curvature of not less than 2.5 mm.
- 16. Modifications of the vehicle type and extension of approval**
- 16.1. Every modification of the vehicle type shall be notified to the Type Approval Authority which approved the vehicle type. Type Approval Authority shall then either:
- (a) Decide, in consultation with the manufacturer, that a new type approval is to be granted, or
 - (b) Apply the procedure contained in paragraph 16.1.1. (Revision) and, if applicable, the procedure contained in paragraph 16.1.2. (Extension).
- 16.1.1. Revision
- When particulars recorded in the information folder have changed and the Type Approval Authority considers that the modifications made are unlikely to have an appreciable adverse effect, and that in any case the vehicle still complies with the requirements, the modification shall be designated a "revision".
- In such a case, the Type Approval Authority shall issue the revised pages of the information folder as necessary, marking each revised page to show clearly the nature of the modification and the date of re-issue. A consolidated, updated version of the information folder, accompanied by a detailed description of the modification, shall be deemed to meet this requirement.
- 16.1.2. Extension
- The modification shall be designated an "extension" if, in addition to the change of the particulars recorded in the information folder,
- (a) Further inspections or tests are required, or
 - (b) Any information on the communication document (with the exception of its attachments) has changed, or
 - (c) Approval to a later series of amendments is requested after its entry into force.
- 16.2. Confirmation or refusal of approval, specifying the alterations, shall be communicated to the Parties to the Agreement which apply this Regulation by means of a form conforming to the model in Annex 4 to this Regulation. In addition, the index to the information package, attached to the communication document, shall be amended accordingly to show the date of the most recent revision or extension.
- 16.3. The Type Approval Authority issuing the extension of approval shall assign a series number to each communication form drawn up for such an extension.

17. Conformity of production

- 17.1. The conformity of production procedure shall comply with those set out in the Agreement, Appendix 2, (E/ECE/324-E/ECE/TRANS/505/Rev.2).
- 17.2. Every vehicle approved under this Regulation shall be so manufactured as to conform to the type approved by meeting the requirements set out in paragraph 15. above.

18. Penalties for non-conformity of production

- 18.1. The approval granted in respect of a vehicle type pursuant to this Regulation may be withdrawn if the requirement laid down in paragraph 17.1. above is not complied with or if the vehicle fails to pass the checks prescribed in paragraph 17.2. above.
- 18.2. If a Party to the Agreement which applies this Regulation withdraws an approval it has previously granted, it shall forthwith so notify the other Contracting Parties applying this Regulation by means of a copy of the approval form bearing at the end, in large letters, the signed and dated annotation "APPROVAL WITHDRAWN".

19. Production definitively discontinued

If the holder of the approval completely ceases to manufacture a type of vehicle approved in accordance with this Regulation, he shall so inform the authority which granted the approval. Upon receiving the relevant communication, that authority shall inform thereof the other Parties to the Agreement applying this Regulation by means of a copy of the approval form bearing at the end, in large letters, the signed and dated annotation "PRODUCTION DISCONTINUED".

20. Names and addresses of Technical Services responsible for conducting approval tests, and of Type Approval Authorities

The Parties to the Agreement applying this Regulation shall communicate to the United Nations Secretariat the names and addresses of the Type Approval Authorities responsible for conducting approval tests and of the Administrative Departments which grant approval and to which forms certifying approval or refusal or extension or withdrawal of approval, issued in other countries, are to be sent.

21. Transitional provisions

- 21.1. As from the official date of entry into force of the ~~03~~ **04** series of amendments to this Regulation, no Contracting Party applying this Regulation shall refuse an application for approval under this Regulation as amended by the ~~03~~ **04** series of amendments.
- 21.2. As from ~~12 months after entry into force of the 03 series of amendments to this Regulation~~, **[12 months after entry into force of the 04 series of amendments to this Regulation]** Contracting Parties applying this Regulation shall grant approvals to a type of device for indirect vision only if the type meets the requirements of this Regulation as amended by the ~~03~~ **04** series of amendments.
- 21.3. As from ~~18 months after entry into force of the 03 series of amendments to this Regulation~~, **[18 months after entry into force of the 04 series of amendments to this Regulation]**, Contracting Parties applying this Regulation shall grant approvals to a type of vehicle with regard to the installation of devices for indirect vision only if the type of vehicle meets the requirements of this Regulation as amended by the ~~03~~ **04** series of amendments.
- ~~21.4. As from 24 months after entry into force of the 03 series of amendments to this Regulation, Contracting Parties applying this Regulation may refuse to recognize approvals of a type of vehicle with regard to the installation of a camera monitor device for indirect vision or type of camera monitor device for indirect vision which have not been granted in accordance with the 03 series of amendments to this Regulation.~~
- 21.5. As from 26 January 2010 for vehicles of category M₁ and N₁ and from 26 January 2007 for vehicles of other categories, Contracting Parties applying this Regulation may refuse to recognize approvals of a device for indirect vision which have not been granted in accordance with the 02 series of amendments to this Regulation.
- 21.6. Approvals which were granted to devices for indirect vision of Classes I or III pursuant to this Regulation in its original form (00 series) or modified by the 01 or 02 **or 03** series of amendments before the date of entry into force of this series of amendments shall remain valid.
- 21.7. Notwithstanding the provisions of paragraph 21.2, approvals which were granted to mirrors of Classes II, IV, V, VI or VII pursuant to this Regulation as modified by the 02 **or 03** series of amendments before the date of entry into force of this series of amendments shall remain valid.
- 21.8. The provisions of this Regulation shall not prohibit the approval of a type of vehicle with regard to the mounting of devices for indirect vision pursuant to this Regulation as modified by the ~~03~~ **04** series of amendments, if all or part of the devices for indirect vision of Classes I or III, with which it is fitted, bear the approval mark prescribed by this Regulation in its original form (00 series) or modified by the 01 or 02 **or 03** series of amendments.

-
- 21.9. The provisions of this Regulation shall not prohibit the approval of a type of vehicle with regard to the mounting of devices for indirect vision pursuant to this Regulation as modified by the ~~03~~ **04** series of amendments, if all or part of the rear-view mirrors of Classes II, IV, V, VI or VII, with which it is fitted, bear the approval mark prescribed by the 02 ~~or~~ **03** series of amendments of this Regulation.
- [21.9. Notwithstanding the provisions of paragraphs 21.2. and 21.5. above, for the purpose of replacement parts, Contracting Parties applying this Regulation shall continue to grant approvals according to the 01 series of amendments to this Regulation, to devices for indirect vision of Classes I to V and VII for use on vehicle types which have been approved before 26 January 2006 pursuant to the 01 series of amendments of Regulation No. 46 and to devices for indirect vision of Class VI for use on vehicles which have been approved before 26 January 2007 pursuant to the 01 series of amendments of Regulation No. 46, and, where applicable, subsequent extensions to these approvals.]**
- 21.10. Notwithstanding the provisions of paragraphs 21.2., ~~and 21.4. and 21.5.~~ above, for the purpose of replacement parts Contracting Parties applying this Regulation shall continue to grant approvals according to 02 ~~and~~ **03** series of amendments to this Regulation, to devices for indirect vision for use on vehicle types which have been approved before the date mentioned in paragraph 21.2 pursuant to the 02 ~~or~~ **03** series of amendments of Regulation No. 46, and, where applicable, subsequent extensions to these approvals.
- 21.11. [Notwithstanding the transitional provisions above, this [04] series of amendments to Regulation No. 46 shall become applicable to camera-monitor devices for indirect vision of Classes I to IV and VII as soon as the ISO-standard mentioned in paragraph 6.2.2.2.5. has been approved by ISO and adopted by the World Forum WP.29]**
- 21.12. As from the official date of entry into force of the 04 series of amendments to this Regulation, no Contracting Party applying this Regulation shall refuse an application for approval under this Regulation as amended by the 04 series of amendments.
- 21.13. As from 30 June 2014, Contracting Parties applying this Regulation shall grant approvals to a type of device for indirect vision only if the type of device meets the requirements of this Regulation as amended by the 04 series of amendments.
- 21.14. As from 30 June 2014, Contracting Parties applying this Regulation shall grant approvals to a type of vehicle with regard to the installation of devices for indirect vision only if the type of vehicle meets the requirements of this Regulation as amended by the 04 series of amendments.
- 21.15. As from 30 June 2015, Contracting Parties applying this Regulation shall not be obliged to accept approvals of a type of vehicle or type of device for indirect vision which have not been granted in accordance with the 04 series of amendments to this Regulation.
- 21.16. Notwithstanding paragraph 21.15., type approvals granted to the preceding series of amendments to the Regulation, which are not affected by the 04 series of amendments, shall remain valid and Contracting Parties applying this Regulation

shall continue to accept them.

21.17. Contracting Parties applying this Regulation shall not refuse to grant extensions of type approvals for existing types of vehicles or devices, which are not affected by the 04 series of amendments, granted according to the 03 series of amendments to this Regulation

Kommentar [RD1]: To be updated after decision

ANNEX 1

**INFORMATION DOCUMENT FOR TYPE APPROVAL OF A
DEVICE FOR INDIRECT VISION**

The following information, if applicable, shall be supplied in triplicate and must include a list of contents.

Any drawings shall be supplied in appropriate scale and in sufficient detail on size A4 paper or on a folder of A4 format.

Photographs, if any, shall show sufficient detail.

1. Make (trade name of manufacturer):
2. Type and general commercial description(s):
3. Means of identification of the type, if indicated on the device:
4. Category of vehicle for which the device is intended:
5. Name and address of manufacturer:
6. Location and method of affixing of the approval mark:
7. Address(es) of assembly plant(s):
8. Mirrors (state for each mirror):
- 8.1. Variant:
- 8.2. Drawing(s) for the identification of the mirror:
- 8.3. Details of the method of attachment:
9. Devices for indirect vision other than mirrors:
- 9.1. Type and characteristics (such as a complete description of the device):
- 9.1.1. In the case of camera-monitor device, the detection distance (mm), contrast, luminance range, glare correction, display performance (black and white/colour) image repetition frequency, luminance reach of the monitor:
- 9.2. Sufficiently detailed drawings to identify the complete device including installation instructions; the position for the type-approval mark has to be indicated on the drawings:

Kommentar [RD2]: To be updated after final agreement of requirements

ANNEX 2

**INFORMATION DOCUMENT FOR TYPE-APPROVAL OF A VEHICLE WITH
RESPECT TO THE INSTALLATION OF DEVICES FOR INDIRECT VISION**

The following information, if applicable, shall be supplied in triplicate and include a list of contents.

Any drawings shall be supplied in appropriate scale and in sufficient detail on size A4 paper or on a folder of A4 format.

Photographs, if any, shall show sufficient detail.

General

1. Make (trade name of manufacturer):
2. Type and general commercial description(s):
3. Means of identification of type, if marked on the vehicle (b):
4. Location of that marking:
5. Category of vehicle (c):
6. Name and address of manufacturer:
.....
7. Address(es) of assembly plant(s):

General construction characteristics of the vehicle

8. Photograph(s) and/or drawing(s) of a representative vehicle:
9. Driving cab (forward control or bonneted) ¹⁾
10. Driving position: left/right ¹⁾
- 10.1. The vehicle is equipped to be driven in right-hand/left hand traffic ¹⁾
11. Range of vehicle dimensions (overall):
- 11.1. For chassis without bodywork:

¹⁾ Delete where not applicable.

- 11.1.1. Width ²⁾:
- 11.1.1.1. Maximum permissible width:
- 11.1.1.2. Minimum permissible width:
- 11.2. For chassis with bodywork:
- 11.2.1. Width ²⁾:
- 12. Bodywork
- 12.1. Devices for indirect vision
- 12.1.1. Mirrors:
- 12.1.1.1. Drawing(s) showing the position of the mirror relative to the vehicle structure:
.....
- 12.1.1.2. Details of the method of attachment including that part of the vehicle structure to which it is attached:
- 12.1.1.3. Optional equipment which may affect the rearward field of vision:
- 12.1.1.4. A brief description of the electronic components (if any) of the adjustment device:
- 12.1.2. Devices for indirect vision other than mirrors:
- 12.1.2.1. Sufficiently detailed drawings with the installation instructions:

²⁾ "Overall width" of a vehicle means a dimension which is measured according to ISO standard 612-1978, term No. 6.2. In case of vehicles of category other than M₁, in addition to the provisions of that standard, when measuring the vehicle width the following devices must not be taken into account:

- (a) customs sealing devices and their protection,
- (b) devices for securing the tarpaulin and their protection,
- (c) tyre failure tell-tale devices,
- (d) protruding flexible parts of a spray-suppression system,
- (e) lighting equipment,
- (f) for buses, access ramps in running order, lifting platforms and similar equipment in running order provided that they do not exceed 10 mm from the side of the vehicle and the corners of the ramps facing forwards or rearwards are rounded to a radius of not less than 5 mm; the edges must be rounded to a radius of not less than 2.5 mm,
- (g) devices for indirect vision,
- (h) tyre-pressure indicators,

-
- (i) retractable steps,
 - (j) the deflected part of the tyre walls immediately above the point of contact with the ground.

ANNEX 3

COMMUNICATION

(Maximum format: A4 (210 x 297 mm))

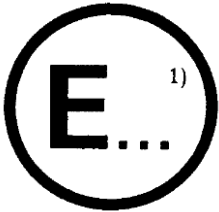

issued by: Name of administration:

- concerning ²⁾: Approval granted
 Approval extended
 Approval refused
 Approval withdrawn
 Production definitively discontinued

of a type of device for indirect vision pursuant to Regulation No. 46

Approval No.:

Extension No.:

- 1. Trade name or mark of device:
- 2. Manufacturer's name for the type of device:
- 3. Manufacturer's name and address:
- 4. If applicable, name and address of Manufacturer's representative:
- 5. Submitted for approval on:
- 6. Technical Service responsible for conducting approval tests:
- 7. Date of report issued by that service:

¹⁾ Distinguishing number of the country which has granted/extended/refused/withdrawn approval (see approval provisions in the Regulations).

²⁾ Strike out what does not apply.

-
8. Number of report issued by that service:
 9. Brief description:
Identification of the device: mirror, camera/monitor, other device ²⁾
Device for indirect vision of Class I, II, III, IV, V, VI, S ²⁾
Symbol Δ
2m as defined in paragraph 6.3.1.1. of this Regulation: yes/no ²⁾
 10. Position of the approval mark:
 11. Reason(s) for extension (if applicable):
 12. Approval granted/refused/extended/withdrawn ²⁾
 13. Place:
 14. Date:
 15. Signature:
 16. The list of documents deposited with the Type Approval Authority which has granted approval is annexed to this communication and may be obtained on request.

ANNEX 4
COMMUNICATION

(Maximum format: A4 (210 x 297 mm))

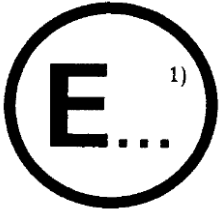

1)

issued by: Name of administration:

- concerning ²⁾: Approval granted
 Approval extended
 Approval refused
 Approval withdrawn
 Production definitively discontinued

of a type of vehicle with regard to the mounting of devices for indirect vision pursuant to Regulation No. 46

Approval number:

Extension No.:

1. Make (trade name of manufacturer):
2. Type and general commercial description(s):
3. Means of identification of type, if marked on the vehicle:
- 3.1. Location of that marking:
4. Category of vehicle: (M₁, M₂, M₃, N₁, N₂ □□7.5 t, N₂ > 7.5 t, N₃) ²⁾
5. Name and address of manufacturer:
6. Address(es) of the production plant(s):

¹⁾ Distinguishing number of the country which has granted/extended/refused/withdrawn approval (see approval provisions in the Regulations).

²⁾ Strike out what does not apply.

7. Additional information: (where applicable): See appendix
8. Technical Service responsible for carrying out the tests:
9. Date of test report:
10. Number of test report:
11. Remarks: (if any): See appendix
12. Place:
13. Date:
14. Signature:
15. The index to the information package lodged with the Type Approval Authority, which may be obtained on request is attached.

Appendix to type approval communication form No. concerning the
type approval of a vehicle with regard to the mounting of devices for
indirect vision under Regulation No.46

1. Trade name or mark of mirrors and supplementary devices for indirect vision and component type-approval number:
2. Class(es) of mirrors and devices for indirect vision (I, II, III, IV, V, VI, VII, S) ²⁾
3. Extension of type approval of the vehicle to cover the following device for indirect vision:
4. Data for identification of the R point of the driver's seating position:
5. Maximum and minimum bodywork width in respect of which the mirror and the devices for indirect vision has been granted type-approval (in the case of chassis/cab referred to in paragraph 15.2.2.3.):
6. The following documents, bearing the type approval number shown above, are annexed to this certificate:
- (a) Drawings showing the mounting of the devices for indirect vision:
- (b) Drawings and plans showing the mounting position and characteristics of the part of the structure where the devices for indirect vision are mounted:
7. Remarks: (e.g. valid for right hand/left hand traffic ²⁾):

ANNEX 5

ARRANGEMENT OF APPROVAL MARK OF A DEVICE FOR INDIRECT VISION

(See paragraph 5.4. of the Regulation)

a=12 mm min.

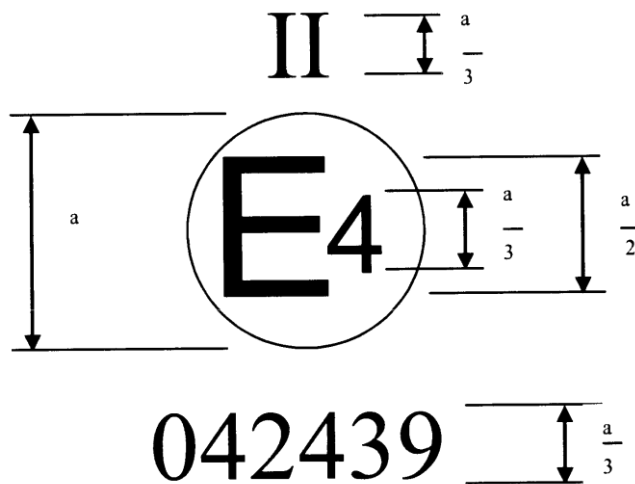

The above approval mark affixed to a device for indirect vision indicates that the mirror is a rear view mirror, of Class II, which has been approved in the Netherlands (E 4) pursuant to Regulation No. 46 and under approval number 042439. The first two digits of the approval number indicate that Regulation No. 46 already included the 04 series of amendments when the approval was granted.

Note: The approval number and the additional symbol must be placed close to the circle and either above or below the "E" or to the left or right of that letter. The digits of the approval number must be on the same side of the "E" and point in the same direction. The additional symbol must be directly opposite the approval number. The use of Roman numerals as approval numbers should be avoided so as to prevent any confusion with other symbols.

ANNEX 6

TEST METHOD FOR DETERMINING REFLECTIVITY

1. Definitions

- 1.1. CIE standard illuminate A ¹⁾: Colorimetric illuminate, respecting the full radiator at $T_{68} = 2\,855.6$ K.
- 1.1.2. CIE standard source A ¹⁾: Gas-filled tungsten filament lamp operating at a correlated colour temperature of $T_{68} = 2,855.6$ K.
- 1.1.3. CIE 1931 standard colorimetric observer ¹⁾: Receptor of radiation whose colorimetric characteristics correspond to the spectral tristimulus values $\bar{x}(\lambda)$, $\bar{y}(\lambda)$, $\bar{z}(\lambda)$ (see table).
- 1.1.4. CIE spectral tristimulus values ¹⁾: Tristimulus values of the spectral components of an equi energy spectrum in the CIE (XYZ) system.
- 1.1.5. Photopic vision ¹⁾: Vision by the normal eye when it is adapted to levels of luminance of at least several cd/m^2 .

2. Apparatus

2.1. General

The apparatus shall consist of a light source, a holder for the test sample, a receiver unit with a photodetector and an indicating meter (see Figure 1), and means of eliminating the effects of extraneous light.

The receiver may incorporate a light-integrating sphere to facilitate measuring the reflectance of non-flat (convex) mirrors (see Figure 2).

2.2. Spectral characteristics of light source and receiver

The light source shall consist of a CIE standard source A and associated optics to provide a near-collimated light beam. A voltage stabiliser is recommended in order to maintain a fixed lamp voltage during instrument operation.

The receiver shall have a photodetector with a spectral response proportional to the photopic luminosity function of the CIE (1931) standard colorimetric observer (see table). Any other combination of illuminate-filter-receptor giving the overall equivalent of CIE standard illuminate A and photopic vision may be used. When an integrating sphere is used in the receiver, the interior surface of the sphere shall be coated with a matt (diffusive) spectrally non-selective white coating.

2.3. Geometrical conditions

The angle of the incident beam (θ) should preferably be 0.44 ± 0.09 rad ($25 \pm 5^\circ$) from the perpendicular to the test surface and shall not exceed the upper limit of the tolerance (i.e. 0.53 rad or 30°). The axis of the receptor shall make an angle (ϕ) with this perpendicular equal to that of the incident beam (see Figure 1). The incident beam upon arrival at the test surface shall have a diameter of not less

⁷⁾ Definitions taken from CIE publication 50 (45), International Electrotechnical Vocabulary, Group 45, Lighting

than 13 mm (0.5 in.). The reflected beam shall not be wider than the sensitive area of the photodetector, shall not cover less than 50 per cent of such area, and as nearly as possible shall cover the same area segment as used during instrument calibration.

When an integrating sphere is used in the receiver section, the sphere shall have a minimum diameter of 127 mm (5 in.). The sample and incident beam apertures in the sphere wall shall be of such a size as to admit the entire incident and reflected light beams. The photodetector shall be so located as not to receive direct light from either the incident or the reflected beam.

2.4. Electrical characteristics of the photodetector-indicator unit

The photodetector output as read on the indicating meter shall be a linear function of the light intensity of the photosensitive area. Means (electrical and/or optical) shall be provided to facilitate zeroing and calibration adjustments. Such means shall not affect the linearity or the spectral characteristics of the instrument. The accuracy of the receptor indicator unit shall be within ± 2 per cent of full scale, or ± 10 per cent of the magnitude of the reading, whichever is the smaller.

2.5. Sample holder

The mechanism shall be capable of locating the test sample so that the axes of the source arm and receptor intersect at the reflecting surface. The reflecting surface may lie within or at either face of the mirror sample, depending on whether it is a first surface, second surface or prismatic "flip" type mirror.

3. Procedure

3.1. Direct calibration method

In the direct calibration method, air is used as the reference standard. This method is applicable for those instruments, which are so constructed as to permit calibration at the 100 per cent point by swinging the receiver to a position directly on the axis of the light source (see Figure 1).

It may be desired in some cases (such as when measuring low-reflectivity surfaces) to use an intermediate calibration point (between 0 and 100 per cent on the scale) with this method. In these cases, a neutral density filter of known transmittance shall be inserted in the optical path, and the calibration control shall then be adjusted until the meter reads the percentage transmission of the neutral density filter. This filter shall be removed before reflectivity measurements are performed.

3.2. Indirect calibration method

The indirect calibration method is applicable in the case of instruments with fixed source and receiver geometry. A properly calibrated and maintained reflectance standard is required. This reference standard should preferably be a flat mirror with a reflectance value as near as possible to that of the test samples.

3.3. Flat mirror measurement

The reflectance of flat mirror samples can be measured on instruments employing either the direct or the indirect calibration method. The reflectance value is read directly from the indicating meter.

3.4. Non-flat (convex) mirror measurement

Measurement of the reflectance of non-flat (convex) mirrors requires the use of instruments which incorporate an integrating sphere in the receiver unit (see Figure 2). If the instrument-indicating meter indicates n_e divisions with a standard mirror of E per cent reflectance, then, with a mirror of unknown reflectance, n_x divisions will correspond to a reflectance of X per cent, in accordance with the formula:

$$X = E \frac{n_x}{n_e}$$

Figure 1

Generalised reflectometer showing experimental set-ups for the two calibration methods

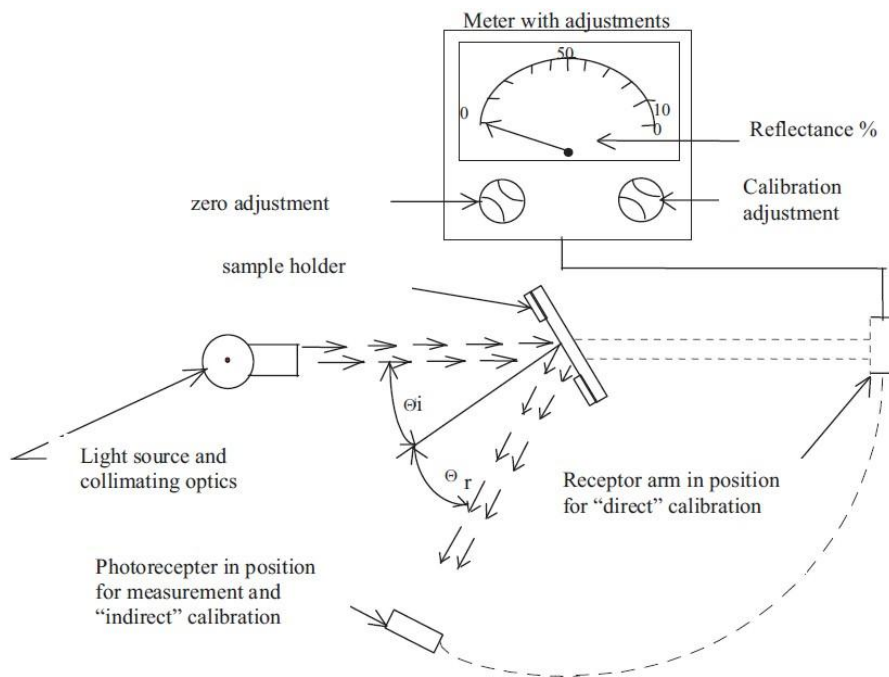
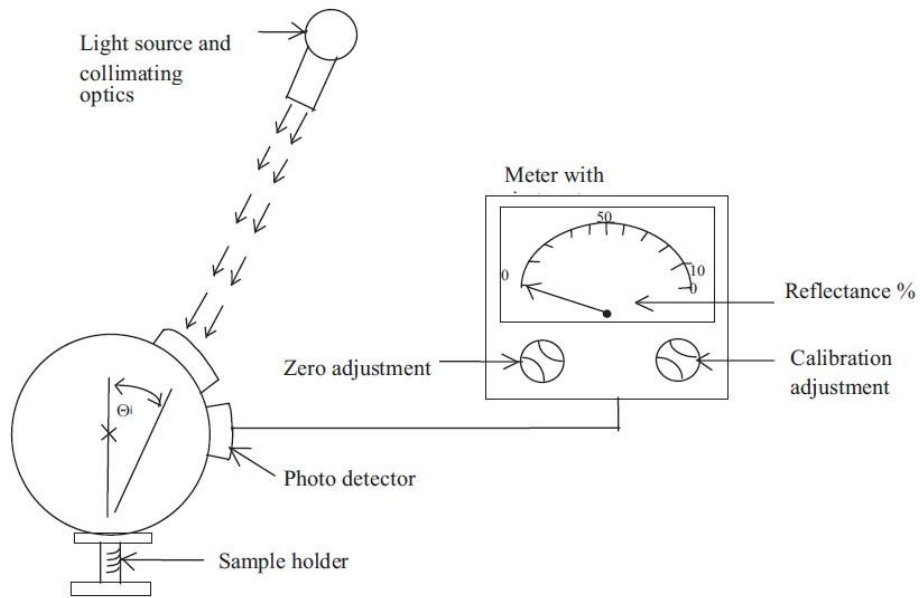

Figure 2

Generalised reflectometer, incorporating an integrating sphere in the receiver



4. Spectral tristimulus values for the cie 1931 standard colormetric observer ²⁾

This table is taken from CIE publication 50 (45) (1970)

λ nm	$\bar{x}(\lambda)$	$\bar{y}(\lambda)$	$\bar{z}(\lambda)$
380	0.001 4	0.000 0	0.006 5
390	0.004 2	0.000 1	0.020 1
400	0.014 3	1.1 4	0.067 9
410	0.043 5	1.2 2	0.207 4
420	0.134 4	0.004 0	0.645 6
430	0.283 9	0.011 6	1.385 6
440	0.348 3	0.023 0	1.747 1
450	0.336 2	0.038 0	1.772 1
460	0.290 8	0.060 0	1.669 2
470	0.195 4	0.091 0	1.287 6
480	0.095 6	0.139 0	0.813 0
490	0.032 0	0.208 0	0.465 2
500	0.004 9	0.323 0	0.272 0
510	0.009 3	0.503 0	0.158 2
520	0.063 3	0.710 0	0.078 2
530	0.165 5	0.862 0	0.042 2
540	0.290 4	0.954 0	0.020 3
550	0.433 4	0.995 0	0.008 7
560	0.594 5	0.995 0	0.003 9
570	0.762 1	0.952 0	0.002 1
580	0.916 3	0.870 0	0.001 7
590	1.026 3	0.757 0	0.001 1
600	1.062 2	0.631 0	0.000 8
610	1.002 6	0.503 0	0.000 3
620	0.854 4	0.381 0	0.000 2
630	0.642 4	0.265 0	0.000 0
640	0.447 9	0.175 0	0.000 0
650	0.283 5	0.107 0	0.000 0
660	0.164 9	0.061 0	0.000 0
670	0.087 4	0.032 0	0.000 0
680	0.046 8	0.017 0	0.000 0
690	0.022 7	0.008 2	0.000 0
700	0.011 4	0.004 1	0.000 0
710	0.005 8	0.002 1	0.000 0
720	0.002 9	0.001 0	0.000 0
730	0.001 4	0.000 5	0.000 0
740	0.000 7	0.000 2 (*)	0.000 0
750	0.000 3	0.000 1	0.000 0
760	0.000 2	0.000 1	0.000 0
770	0.000 1	0.000 0	0.000 0
780	0.000 0	0.000 0	0.000 0

(*) Changed in 1966 (from 3 to 2)

²⁾ Abridged table. The values of $\bar{y}(\lambda) = V(\lambda)$ are rounded off to four decimal places

Explanatory figure

Example of device for measuring the reflection factor of spherical mirrors

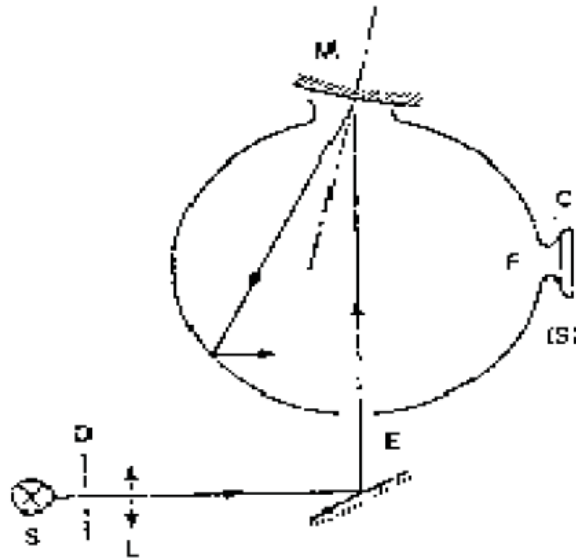

- C = Receiver
- D = Diaphragm
- E = Window of entry
- F = Window of measurement
- L = Lens
- M = Object window
- S = Light source
- (S) = Integrating sphere

ANNEX 7

PROCEDURE FOR DETERMINING THE RADIUS OF CURVATURE „r“ OF THE REFLECTING SURFACE OF A MIRROR

1. Measurement

1.1. Equipment

A “spherometer” similar to the one described in Figure 1 of this annex having the indicated distances between the tracing pin of the dial gauge and the fixed legs of the bar is used.

1.2. Measuring points

1.2.1. The principal radii of curvature shall be measured at three points situated as close as possible to positions at one-third, one-half and two-thirds of the distance along the arc of the reflecting surface passing through the centre of this surface and parallel to segment b, or of the arc passing through the centre of the reflecting surface which is perpendicular to it if this arc is the longer.

1.2.2. Where, owing to the size of the reflecting surface, it is impossible to obtain measurements in the directions defined in paragraph 2.1.1.6. of this Regulation, the Technical Services responsible for the tests may take measurements at the said point in two perpendicular directions as close as possible to those prescribed above.

2. Calculation of the radius of curvature “r”

“r” expressed in mm is calculated from the formula:

$$r = \frac{r_p 1 + r_p 2 + r_p 3}{3}$$

where:

- r_{p1} = the radius of curvature at the first measuring point,
 r_{p2} = the radius of curvature at the second measuring point,
 r_{p3} = the radius of curvature at the third measuring point.

Figure 1
Spherometer

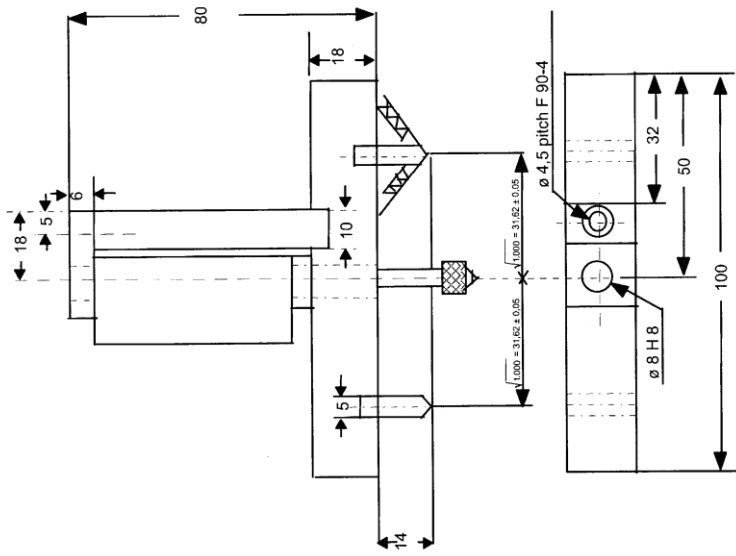
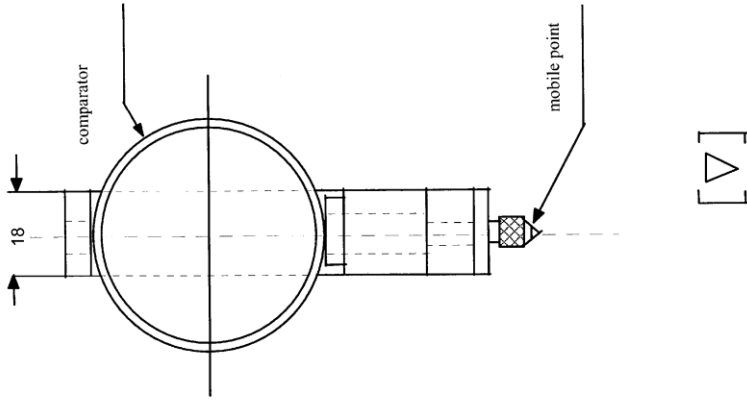

ANNEX 8

PROCEDURE FOR DETERMINING THE "H" POINT AND THE ACTUAL TORSO ANGLE FOR SEATING POSITIONS IN MOTOR VEHICLES ¹⁾

Appendix 1 - Description of the three dimensional "H" point machine (3-D H machine) ¹⁾

Appendix 2 - Three-dimensional reference system ¹⁾

Appendix 3 - Reference data concerning seating positions ¹⁾

¹⁾ The procedure is described in Annex 1 to the Consolidated Resolution on the Construction of Vehicles (RE.3) (document ECE/TRANS/WP.29/78/Rev.2).

ANNEX 9

(Reserved)

ANNEX 10

CALCULATION OF THE DETECTION DISTANCE

1. Camera monitor devices of class V and VI for indirect vision

1.1. Determination of the smallest discernable detail

The smallest discernable detail of the naked eye shall be defined according to standard ophthalmologic tests like the Landolt C test or the Triangle Orientation Discrimination (TOD) test. The smallest discernable detail at the centre of the viewing system can be determined using the Landolt C test or the TOD test. In the rest of the viewing area the smallest discernable detail may be estimated from the centrally determined smallest discernable detail and the local image deformation. For instance, in the case of a digital camera the smallest discernable detail at a given pixel location (in the monitor) scales inversely with the solid angle of the pixel.

1.1.1. Landolt-C test

In the Landolt-C test, test symbols are judged by the subject under test. In accordance with this test the smallest discernable detail is defined as the visual angle of the gap size of the Landolt C symbol at threshold size and is expressed in arcmin. The threshold size corresponds to the size at which the subject judges the orientation correctly in 75 per cent of the trials. The smallest discernable detail is determined in a test involving a human observer. A test chart containing test symbols is placed in front of the camera and the observer judges the orientation of test symbols from the monitor. From the threshold gap size of the Landolt C test symbol d (m) and the distance between the test pattern and the camera D (m) the smallest discernable detail ω_c (arcmin) is calculated as follows:

$$\omega_c = \frac{d}{D} \cdot \frac{180 \cdot 60}{\pi}$$

1.1.2. TOD test

The Landolt C test can be used to determine the smallest discernable detail of the camera-monitor system. However, for sensor systems it is more suitable to use the TOD (Triangle Orientation Discrimination) method which is similar to the Landolt C method, but involves equilateral triangular test patterns. The Triangle Orientation Discrimination method is described in detail by Bijl & Valeton (1999), who provide practical guidelines on how to perform a TOD measurement. In the method, triangular test patterns (see Figure 1) are viewed through the viewing system under test. Each triangle can have one out of four possible orientations (apex up, left, right or down) and the observer indicates/guesses for each triangle its orientation. When this procedure is repeated for many (randomly oriented) triangles of different sizes the fraction of correct responses can be plotted (see Figure 2), and increases with test pattern size. The threshold is defined as the point at which the fraction correct crosses the 0.75 level and can be obtained by fitting a smooth function through the data (see Bijl & Valeton, 1999). Critical perception is reached when the critical object diameter equals two times the width of the triangle at threshold size. The smallest discernable detail (ω_c) is equal to 0.25 times the width of the triangle at threshold size. This means that, from the threshold triangle width w (in m) and the distance between test pattern and the camera D (in m) the smallest discernable detail ω_c (in arcmin) is calculated as follows:

$$\omega_c = \frac{w}{4 \cdot D} \cdot \frac{180 \cdot 60}{\pi}$$

Figure 1

Triangular test patterns used in the Triangle Orientation Discrimination (TOD) method



Figure 2

Typical relationship between the size of the triangle and the fraction of correct responses.

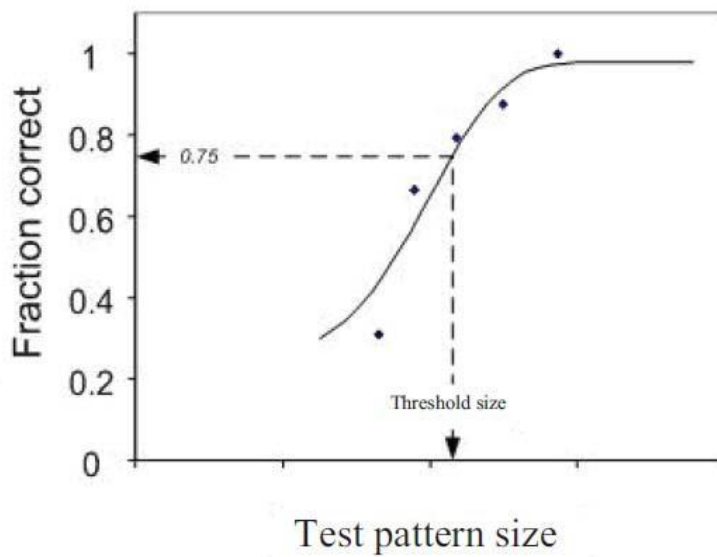

1.2. Determination of the critical viewing distance of the monitor

For a monitor having certain dimensions and properties, the distance to the monitor can be calculated within which the detection distance is dependent only on the performances of the camera. The critical viewing distance r_{crit} is defined as the distance at which the smallest discernable detail displayed on the monitor spans 1 arc min measured from the eye (the acuity threshold of a standard observer).

$$r_{\text{mcrit}} = \frac{\delta \cdot 60 \cdot 180}{\pi}$$

where:

r_{mcrit} : critical viewing distance of the monitor (m)

δ : size of the smallest discernable detail on the monitor (m)

1.3. Determination of the detection distance

1.3.1. Maximum detection distance within the critical viewing distance where, due to the installation, the distance eye-monitor is less than the critical viewing distance, the maximum attainable detection distance is defined as:

$$r_{\text{dclose}} = \frac{D_0 \cdot 60 \cdot 180}{\omega_c \cdot \pi \cdot f}$$

where:

r_{dclose} : detection distance (m)

D_0 : diameter of the critical object (m) according to paragraph 2.1.2.6.; for the calculation of r_{dclose} for class V and VI devices, a representative value of 0,30 m shall be used

f : threshold increasing factor, which is equal to 8

ω_c : smallest discernable detail (arcmin)

1.3.2. Detection distance greater than the critical viewing distance. Where, due to the installation, the distance eye-monitor is more than the critical viewing distance, the maximum obtainable detection distance is defined as:

$$r_{\text{dfar}} = \frac{r_{\text{mcrit}}}{r_m} r_{\text{dclose}} \quad (\text{m})$$

where:

r_{dfar} : detection distance for distances larger than the critical viewing distance (m)

r_{dclose} : detection distance for distances smaller than the critical viewing distance (m)

r_m : viewing distance, i.e. distance between eye and monitor (m)

r_{mcrit} : critical viewing distance (m)

2. Secondary functional requirements **for camera monitor devices of class V and VI**

Based on the installation conditions, a determination shall be made to discover whether the entire device can still satisfy the functional requirements listed in paragraph 6.2.2. of this Regulation, especially the glare correction, the maximum

and the minimum luminance of the monitor. It shall also be determined the degree to which the glare correction will be addressed and the angle at which sunlight can strike a monitor and these shall be compared to the corresponding measuring results from the system measurements. This can be either based on a CAD-generated model, a determination of the angles of light for the device when mounted on the relevant vehicle, or by carrying out relevant measurements on the relevant vehicle as described in paragraph 6.2.2.2. of this Regulation.

ANNEX 11

DETERMINATION OF THE DISPLAYED OBJECT SIZE

1. Camera monitor devices **of class V and VI** for indirect vision

1.1. General

Determination of the displayed object size considers the possible appearance of smear. The impact on the monitors image and consequence is the occultation of the field of view and therefore of the object. The following differentiation is made:

1.2. Case A: Smear appears

1.2.1. Step 1: Under the condition described in paragraph 6.2.2.2.1.2., measure the width (s) of the vertical bar displayed on the monitor e.g. with a measurement microscope.

1.2.2. Step 2: Place the object at a defined distance from the camera. Measure the width of the object displayed on the monitor (b) in a situation without real sun light condition e.g. with a measurement microscope.

1.2.3. Step 3: Calculate the residual object width (α) according to the following equation:

$$\alpha ['] = 60 \times 2 \times \arctan \frac{b-s}{2 \times r}$$

where:

α : residual width of the object displayed on the monitor (with smear) (minutes of arc)

b: width of the object displayed on the monitor (without smear) (mm)

s: width of the smear (mm)

r: viewing distance (mm)

1.3. Case B: Smear does not appear

1.3.1. Step 1: Place the object at a defined distance from the camera. Measure the width of the object displayed on the monitor (b) in a situation without real sun light condition e.g. with a measurement microscope.

1.3.2. Step 2: Calculate the object width (α) according to the following equation:

$$\alpha ['] = 60 \times 2 \times \arctan \frac{b}{2 \times r}$$

where:

α : width of the object displayed on the monitor (without smear) (minutes of arc)

b: width of the object displayed on the monitor (without smear)

(mm) r: viewing distance (mm)

1.4. Data supplied by the instructions for use

In case of Class V and VI camera monitor devices the instructions for use shall include a table that shows the minimum and maximum mounting height of the camera above ground under consideration of different viewing distances. The camera must be mounted within the applicable height range. The viewing distances shall be selected from the intended context of use. The following table shows an example.

Viewing distance	0.5 m	1.0 m	1.5 m	2.0 m	2.5 m
Minimum mounting height	Para. 1.4.1.	Para. 1.4.1.	Para. 1.4.1.	Para. 1.4.1.	Para. 1.4.1.
Maximum mounting height	Para. 1.4.2.	Para. 1.4.2.	Para. 1.4.2.	Para. 1.4.2.	Para. 1.2.2.

1.4.1. The value of the minimum mounting height is the same for all viewing distances as it is independent of the viewing distance. It is determined by the dimensions of the field of vision and the field of view of the camera. Use the following working steps for determination of the minimum mounting height.

1.4.1.1. Step 1: Draw the intended field of vision on ground.

1.4.1.2. Step 2: Place the camera above the field of vision in such a way that the camera is viewing the field of vision. The lateral position shall be in accordance with the intended mounting position at the vehicle.

1.4.1.3. Step 3: Change the height of the camera above ground in such a way, that the field of vision displayed on the monitor covers an area at least as large as the field of vision. Furthermore, the field of vision display should encompass the entire monitor screen.

1.4.1.4. Step 4: Measure the height between camera and ground which is the minimum mounting height. Report the result value.

1.4.2. The value of the maximum mounting height is different for different viewing distances as the displayed object size varies with the mounting height. Use the following working steps for determination of the maximum mounting height:

1.4.2.1. Step 1: Determine the minimum width b_{\min} of the critical object displayed on the monitor for each viewing distance.

$$b_{\min} = 2 \times r \times \tan \frac{8'}{2 \times 60}$$

where:

r: viewing distance in mm

b_{\min} : minimum width of the critical object displayed on the monitor in mm

1.4.2.2. Step 2: Place the critical object inside the drawn intended field of vision in a position at which the distance between the critical object and the camera is largest. The illumination conditions shall be in such a way that the critical object is clearly

visible on the monitor.

1.4.2.3. Step 3: Select the first value of the possible viewing distances.

1.4.2.4. Step 4: Change the height of the camera above ground in such a way, that the residual width B of the object displayed on the monitor is equal to the minimum width allocated to that viewing distance.

$$B = b_{\min}$$

where:

B: residual width of the object displayed on the monitor (which is "b" in cases without smear and "b – s" in cases with smear) in mm (see paragraph 1.1. General)

1.4.2.5. Step 5: Measure the height between camera and ground which is the maximum mounting height allocated to that viewing distance. Report the result value.

1.4.2.6. Step 6: Repeat the aforementioned steps 4 and 5 for the other viewing distances.

[As an alternative from GRSG-101-03, add new Annex 11, to read:

"Annex 11

MODEL OF CERTIFICATE OF CONFORMITY

I the undersigned.....
(surname and name)

Testify that the device for indirect vision described below:

Make:.....

Type:.....

is in total conformity with the type approved

at on
(place of approval) (date)

as described in the communication form bearing approval No.

Identification of the main component(s):

Component:Marking:

Done at: on:

Manufacturer's full address and stamp:

Signature : (please specify position)"]

**PROVISIONS FOR THE TYPE APPROVAL OF CAMERA-MONITOR DEVICES (CMS) OF Class I
TO IV [AND VII] FIELD OF VISION**

1. Requirements

The camera-monitor device (CMS) of class I to IV [and VII] of field of vision shall meet the provisions of standard ISO-16505:[201x].

2. Notwithstanding paragraph 1 of annex XX the CMS shall fulfil the following requirements

2.1. System documentation

For testing and evaluation of the CMS according to ISO 16505:[201x], the following documents shall be provided by the applicant:

- Technical specification
- Operator's manual.

2.2. Adjusted default view

The field of view of the CMS may be changed in the horizontal and vertical direction. However the size of the displayed field of view shall not be smaller than the default view as defined in paragraph 6.2.1 of ISO 16505:[201x], with at least the minimum magnification, the average magnification and the resolution as defined in paragraph 6.5 of ISO 16505:[201x].

2.3. Modified view

A temporary modification (manual or automatic) of the default view or the adjusted default view regarding the field of view and/or magnification may be allowed during merging, parking, and turning. The temporary modification shall be indicated to the driver and shall be deactivated automatically. The operator's manual shall inform the driver accordingly.

NOTE For recommendations regarding the modified view in commercial vehicles refer to Annex A.2.1.1 of ISO-16505:[201x].

2.3.1. Changed field of view

Paragraph 6.2.3.1 of ISO 16505:[201x] is not applicable.

2.3.2. Changed magnification factor

Paragraph 6.2.3.2 of ISO 16505:[201x] is not applicable.

2.4. Overlays

Overlays, according to paragraph 4.5.15 of ISO 16505:[201x], are generally allowed. Within the required field of vision only temporary transparent overlays with a transparency of at least 60 % are allowed. Overlays with a transparency of less than 60 % shall be displayed with a maximum size of 1 % of the minimum required FOV, provided that the requirements, described in paragraph 15.2.4.9. are still fulfilled. The test method of Appendix 1 shall be applied.

2.5. Operating readiness (System availability)

The CMS shall be operational as soon as the driver is ready to drive. It shall be recognizable to the driver, if the system is not operational (e.g. CMS failure by i.e. warning indication, display information, absence of status indicator). The operator's manual shall explain the information indicated to the driver.

In order to enable the availability in a reasonable timeframe the switch-on-time for a cold start of the CMS t_{ON} is specified to be $t_{ON} \leq 7$ s.

[NOTE The switch-on-time for a cold start of the CMS t_{ON} corresponds to the time-behavior of folding mirrors.]

2.6. Monitor integration inside the vehicle

The following requirements shall refer to the portion of the monitor which shows the intended field of view.

2.6.1. The obstruction of the view onto the mandatory field of vision on the monitor shall be restricted to a minimum for the view on the appropriate mirror class.

2.6.2. It shall be possible to view the center line of the monitor with a gaze angle not more than $30^\circ + 10^\circ$ ¹ down from the eye point according to number 3. Regarding the maximum angle where the monitor is allowed to be located, the monitor position shall fulfil any individual mirror regulations of the national body. The monitor shall be protected from ambient light or mounted accordingly. The monitor shall be oriented in a way that ambient light does not illuminate the monitor from a central critical specular light direction (see also ISO 15008:2009. The monitor shall be optimized for the design viewing direction.

2.6.3. [The installation of the monitor shall not lead to direct reflections on the surfaces of the windscreen on the area described in paragraph 5.1.3 of UN Regulation No. 125]

2.6.4. The arrangement of the monitor(s) inside the vehicle shall be in such a way as expected by a driver.

This means, that the image of the right side field of view shall be presented to the right of the longitudinal vertical plane through the ocular reference point, defined in paragraph 12.1. The image of the left side field of view shall be presented to the left of the longitudinal vertical plane through the ocular reference point.

[NOTE: A deviation from this arrangement may be discussed allowed for specific vehicles used in typical driving conditions. This is however only allowed in if in scientific case studies significant advantages are shown for alternative arrangements.]

If the CMS shows more than one FOV on one display, non-continuous images shall be clearly separated from each other.

2.6.5. Obstruction of the driver's direct view caused by the installation of the CMS (especially of the monitor) shall be in accordance with the requirements laid down in UN-Regulation No. 125 for vehicles of category M1. For all other categories of vehicles the obstruction of the driver's direct view shall be restricted to a minimum.

¹ This gaze angle is not applicable for vehicles of categories N, M2 and M3 and vehicles with a height of the R-point of more than 700 mm [Note: Reference from UN-R95].

2.7. Luminance and contrast rendering

For luminance and contrast rendering the following requirements applies:

- The minimum luminance contrast at the monitor (including any screen protector) reproducing a high contrast pattern shall be:
 - for direct sunlight condition: 2:1
 - for day condition with diffuse ambient light: 3:1
 - for sunset condition: 2:1
 - for night condition: 10:1²
- **NOTE** The definition of the “luminance contrast” is given in ISO 9241-302:2008. The luminance contrast is measured by “contrast ratio”. According to ISO 9241-302:2008 as well as ISO 15008:2009 the “contrast ratio” is defined as the ratio between the higher luminance L_H (L_{High}) and the lower luminance L_L (L_{Low}). All remaining definitions follow ISO 15008:2009.
- Day condition... **[(definition, to be added (ISO.....))],**
- Night condition for the cameras field of view is replicated in a dark environment such that the maximum illuminance on the objects to be measured shall not exceed 2.0 lx,
- The background luminance of the monitor shall be limited under night condition. Depending on the installation of the monitor inside the vehicle this will reduce annoying reflections on the windscreen or other window panes as well. The maximum background luminance under night condition shall be less than 2.0 cd/m²,
- The instructions for use shall contain a note that sunlight or light from other intense light sources upon the monitor reduces the luminance contrast which may require the driver to be especially alert and attentive.

Kommentar [RD3]: To be added

2.8. Grey scale rendering

A CMS shall have a sufficient grey scale rendering. In order to reproduce a grey scale with distinguishable grey steps according to ISO 15739 (Test method to be applied)

[Note: A test method and limit values will be provided for the 2nd meeting of the IG CMS]

2.9. Smear

Smear causes partial occlusion of the field of view and of the objects. Smear shall be transparent and not be more than 10 % of the maximum luminance value of the image. (

2.10. Point light sources

For safety reasons point light sources (e.g. low beam headlights) shall be rendered as point light sources and be distinguishable.

[Note: A test method and limit values will be provided for the 2nd meeting of the IG CMS]

² ISO 9241-303:2011

2.11. Color noise

Annoying color noise shall be avoided under night condition.

[Note: Test method and limit values are under discussion. Presentation is planned for the 2nd meeting of the IG CMS]

2.12. Geometric distortion

For CMS of Class I, II and III the maximum distortion within the minimum required field of view shall not exceed 20 % relative to recto-linear or pinhole projection.

2.13. Pixel faults

The monitor shall have no visible pixel faults.

2.14. Flicker

The entire image area of the monitor shall be free of flicker for at least 90 % of the user population

For the flicker determination according to [ISO 13406-2: 2001annex B.] the test method of Appendix 2 shall be applied.

2.15. Visual artefacts

Paragraph 6.8.7.3 of ISO 16505:[201x] is not applicable.

2.16. It is recommended to avoid glare and distraction due to reflection of sunlight in the monitor housing. A gloss value of the monitor housing of less than 11 gloss units is recommended, when measured in a 60 ° measurement geometry according to ISO 2813:1994.

2.17. Image formation time

For the image formation time the test method of ISO 9241-305: 2008 shall be fulfilled.

The image formation time of the monitor shall be less than 55 ms at a temperature of 22 °C ±5 °C.

2.18. Failure behavior

Paragraph 6.10 of ISO 16505:[201x] is not applicable.

2.19. Notwithstanding paragraph 7.8.2 of ISO 16505:[201x] for the image quality the test parameters for the camera and the monitor with diffuse sky-light exposure given in Table 1 apply.

Table 1 – Test parameters for the camera and the monitor with diffuse sky-light exposure

Test	Orientation	Property	Unit	Value	Comment
Test parameters “day condition with diffuse	Camera side	Luminance white	cd/m ²	400-800	Luminance white at
		Contrast ratio chart		≥ 20	Luminance white / luminance black

sky- light exposure”	Monitor side	luminance diffuse illuminator	cd/m ²	[1300-1500 cd/m ²] / [4200 cd/m ²]	Luminance at the surface of the diffuse light source
		Inclination angle θ_p reference camera (8) to monitor normal	degree	design viewing directio	
		Inclination angle θ_p light source (6) to monitor	degree	$\theta_{monitor/D} + 15^\circ$	
Results to be reported	Monitor side	Measure the luminance contrast ratio of the test chart image on the monitor			Measure luminance white and luminance black at the monitor and obtain the

Kommentar [RD4]: Under Review →
test requirement is under consideration

NOTE For an inclination angle of $\theta_D = 30^\circ$ and azimuth angle $\Phi_D = 0^\circ$ this test corresponds to ISO 15008:2009/SAE J1757-1 Procedure 2B, Section 4.1.2.5.

2.20. Safety of electronic systems for indirect vision

The requirements to be applied to the safety aspects of electronic systems for indirect vision are given in Appendix 3.

Appendix 1

TEST METHOD FOR THE OVERLAY AND TRANSPARENCY

1. Luminance measurements (paragraph 2.7 of Annex [xx]) are made perpendicular onto the monitor at a portion where the overlay is displayed. Use a 1 degree measurement field within the luminance meter (if necessary the manufacturer shall provide for testing purpose a sufficient large test pattern).
- 1.1. **Step 1: Determination of the luminance of the overlay**
Measure the luminance L1 of the monitor with the overlay switched on whereas the camera captures a black object in that area.
- 1.2. **Step 2: Determination of the luminance without overlay**
Measure the luminance L2 of the monitor with the overlay switched off whereas the camera captures a white object in that area.
- 1.3. **Step 3: Determination of the transparency**
Measure the luminance L3 of the monitor with the overlay switched on whereas the camera captures a white object in that area. The following relation has to be fulfilled:

$$L3 \geq 0,6 * L2 + L1$$

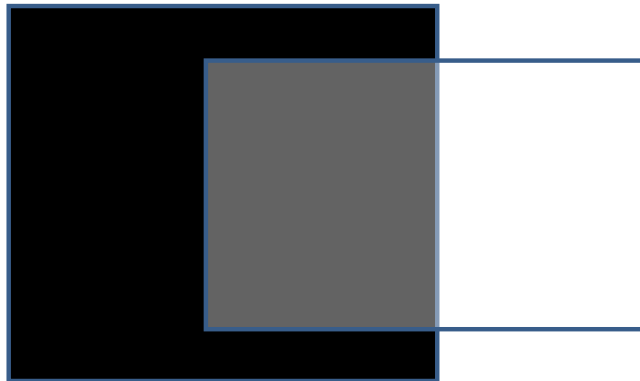

Figure 1:

Appendix 2

TEST METHOD FOR FLICKER

1. The entire image area of the monitor shall be free of flicker for at least 90 % of the user population.
2. The flicker evaluation uses the determination given in Annex B of ISO13406-2: 2001. The following measurement procedure applies:
 - 2.1 Position the camera of the CMS in front of a still scene (e.g. chessboard chart). Use a scene illumination of about 500 lux. Measure the time resolved luminance value of a portion of the monitor that displays a white patch of the chessboard chart. The measurement location should be near the center of the monitor defined size and the measurement direction is perpendicular onto the monitor. Perform a Fourier transform of the luminance-time function for determination of the amount of energy E_{obs} at various frequencies up to 120 Hz. These numbers are then compared to the amounts of energies that people will detect as flicker, the predicted flicker threshold E_{pred} .

If $E_{obs} < E_{pred}$ at every frequency < 120 Hz then it is likely that people will not see flicker.

If $E_{obs} \geq E_{pred}$ at any frequency < 120 Hz then it is likely that people will see flicker.

- 2.2 Determination of E_{obs} , which is the observed energy at every frequency < 120 Hz:

$$E_{obs,n} = DC * AMP_n = A * c_0 * AMP_n = b_0 * L_t^{b_1} * c_0 * AMP_n$$

where:

$$b_0 = 12.45184$$

$$b_1 = -0.16032$$

For L_t , which is the adaption luminance:

Use $L_t = L_{\text{monitor/chart/white/ambient}}$ from ISO 16505:YEAR (paragraph 7.8.2: Test 2: Day condition with diffuse sky-light exposure).

Kommentar [RD5]: Add year

For c_0 , which is the zero Fourier coefficient, and is the dark-room luminance averaged over time.

Use $c_0 = L_{\text{monitor/chart/white}}$ from ISO 16505:YEAR (paragraph 7.8.2: Test 2: Day condition with diffuse sky-light exposure with the diffuse light source switched off).

Kommentar [RD6]: Add year

For AMP_n :

$$AMP_n = \frac{2 * |c_n|}{c_0}$$

For c_n , which is the n th Fourier coefficient. Take the n th Fourier coefficient from the Fourier transform.

- 2.3 Determination of E_{pred} , which is the predicted energy at every frequency < 120 Hz:

$$E_{pred,n} = a * e^{b * f_n}$$

The variables a and b depend on the monitor diagonal as seen from the driver's ocular reference point (paragraph 4.1.4 of ISO 16505: [201x] and is measured in degree (see Table B.1 in the standard ISO 13406-2). For a monitor diagonal $\alpha_{\text{monitor/Diagonal}}$ of less than 20°, variables a and b equals to a = 0.1276 and b = 0.1919.

The monitor diagonal $\alpha_{\text{monitor/Diagonal}}$ is given by the following equation:

$$\alpha_{\text{monitor/Diagonal}} = 2 * \arctan \frac{\text{Diagonal}}{2 * a_{\text{monitor/D}}}$$

where

Diagonal diagonal of the monitor, measured in meters
 $a_{\text{monitor/D}}$ Distance of the ORP to the centre of the monitor coordinate system (see ISO16505:YEAR subclause 4.4.10).

Kommentar [RD7]: Add year

- 2.4 For every frequency < 120 Hz compare the observed energy E_{obs} with the predicted energy E_{pred} and report the result value for passed or failed.

[Appendix 3

SPECIAL REQUIREMENTS TO BE APPLIED TO THE SAFETY ASPECTS OF CAMERA MONITOR SYSTEMS FOR INDIRECT VISION]

[Note: to be provided in due time before the 2nd meeting of the IG CMS]

[Note: As a reference the current paragraphs were linked to the ISO-document 16505:

Paragraph in the Annex xx	Paragraph in the ISO-Document ISO 16505
2.1	6.1
2.2	6.2.2
2.3	6.2.3
2.3.1	6.2.3.1
2.3.2	6.2.3.2
2.4	6.2.5
2.5	6.3
2.6	6.7
2.7	6.8.2 and new (to 7.8.1.2)
2.8	---
2.9	6.8.4.1
2.10	6.8.4.3
2.11	6.8.4.4
2.12	6.8.6
2.13	6.8.7.1
2.14	6.8.7.2 and 7.8.7.2
2.15	6.8.7.3
2.16	6.8.7.4
2.17	6.9.2
2.18	6.10
2.19	7.8.2
2.19 Table 1	7.8.2 Table 7

]