



# **THE DESIGN OF THE UNECE HGV DVS FOR TECH NEUTRAL CAB DESIGN**

**EQUIVALENCE BETWEEN THE EXISTING METHOD AND PROPOSED AMENDMENT**

DR STEVE SUMMERSKILL, PROF. RUSSELL MARSHALL, DR ABBY PATERSON, ANTHONY ELAND

FUNDED BY THE ROAD SAFETY TRUST



# CONTENT

- How the DVS was defined for the London version
- How the standard has been improved for the UNECE version with a separated approach
- Problems with the new version
- Ways forward

## HOW THE DVS WAS DEFINED FOR THE LONDON VERSION

- The London (Transport for London) version of the DVS was defined provide a method which allows an accurate measure of direct vision, which is quantified using a real world measure of direct vision performance, VRU distance
- The accurate measure of Direct vision takes the form of the amount of an assessment volume that can be seen from a standardised eye point
- The real world measure is the distance at which VRU simulations can be seen by the driver

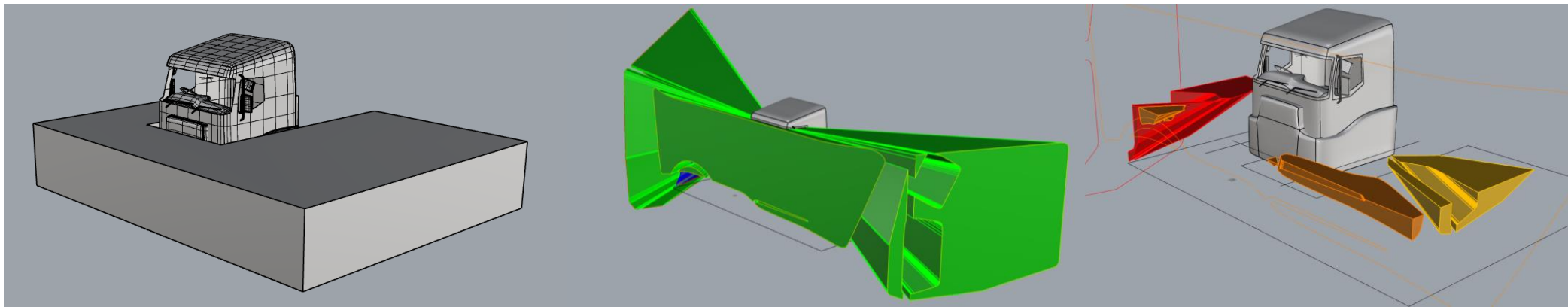

# HOW ARE THE VRU SIMULATIONS DEFINED AND USED

- As per the diagram, an array of VRU simulations is arranged around the vehicle using a consistent method. Each VRU is then moved away from the side of the truck in one axis only
- The portion of the VRU that must be visible was originally proposed as head and shoulders but head and neck is now agreed
- This is followed by example results for the VRU distances

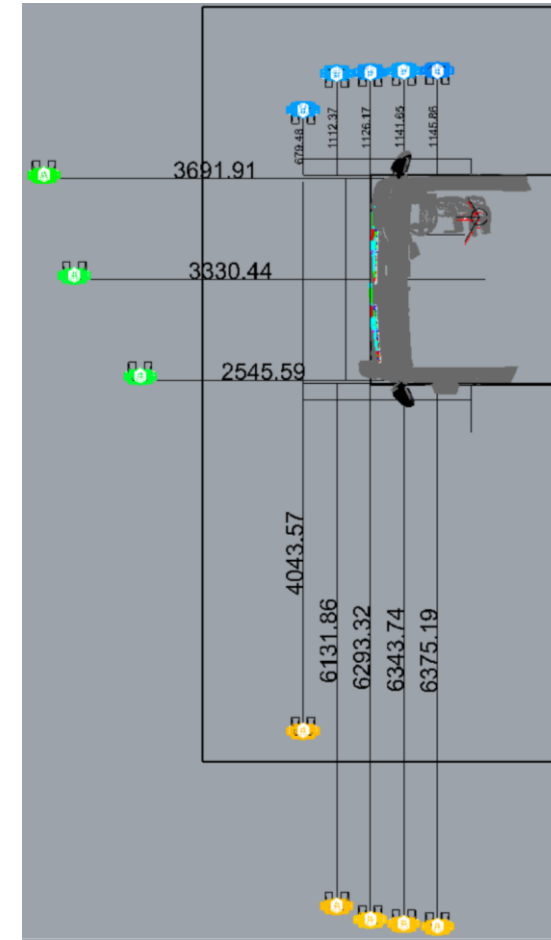
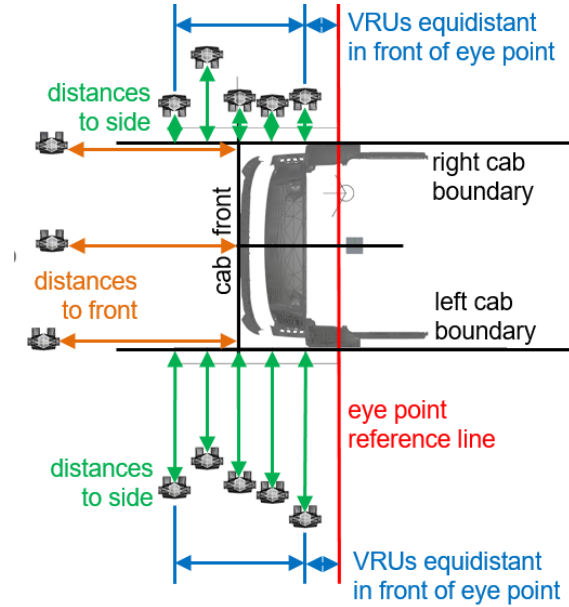

<sup>2</sup>COOK, S., SUMMERSKILL, S., MARSHALL, R., ... et al., 2011. The development of improvements to drivers' direct and indirect vision from vehicles - phase 2. Report for Department for Transport DfT TTS Project Ref: S0906 / V8. Loughborough: Loughborough University and MIRA Ltd. **See section 2.5** <https://hdl.handle.net/2134/8873>

<sup>3</sup>SUMMERSKILL, S. Marshall, R; Paterson, A; Reed, S (2015): Understanding direct and indirect driver vision in heavy goods vehicles. Report. <https://hdl.handle.net/2134/21028>

## EXAMPLE VRU DISTANCE RESULT

- The bottom images shows the placement of the VRU simulations to the front and sides of the vehicle for **head and neck visibility from the simulated eyepoint**.
- Top right shows a plan view of VRU positions

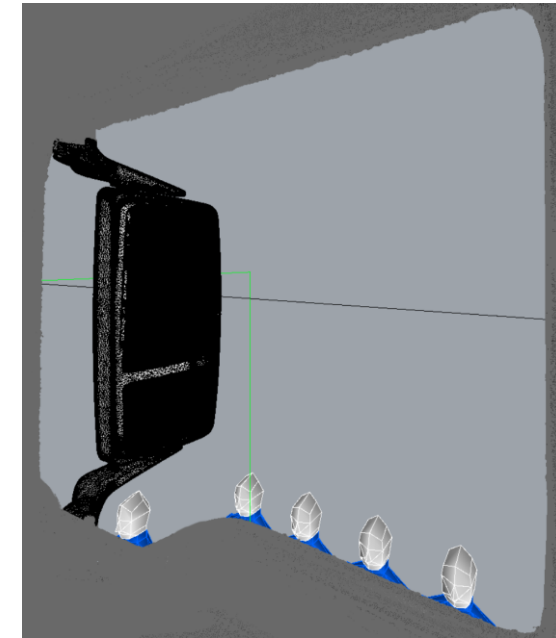
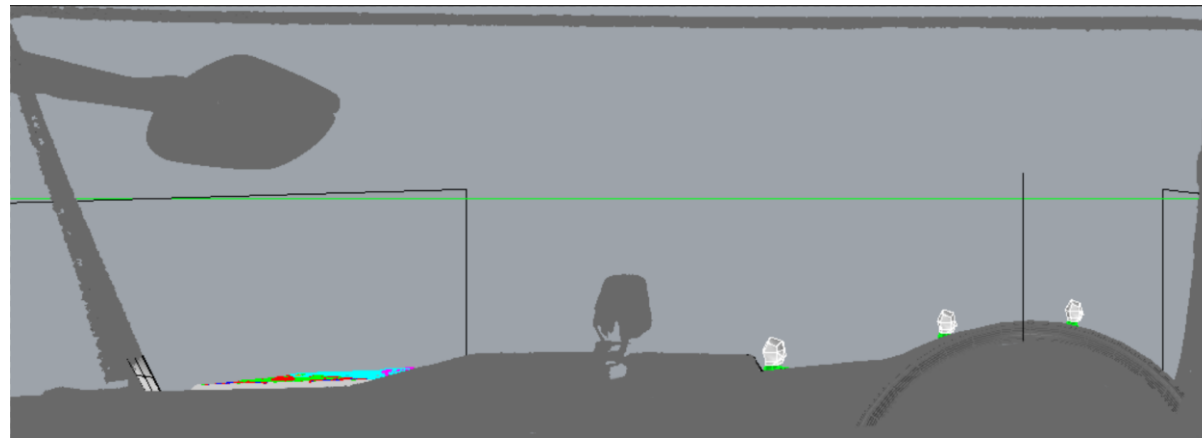
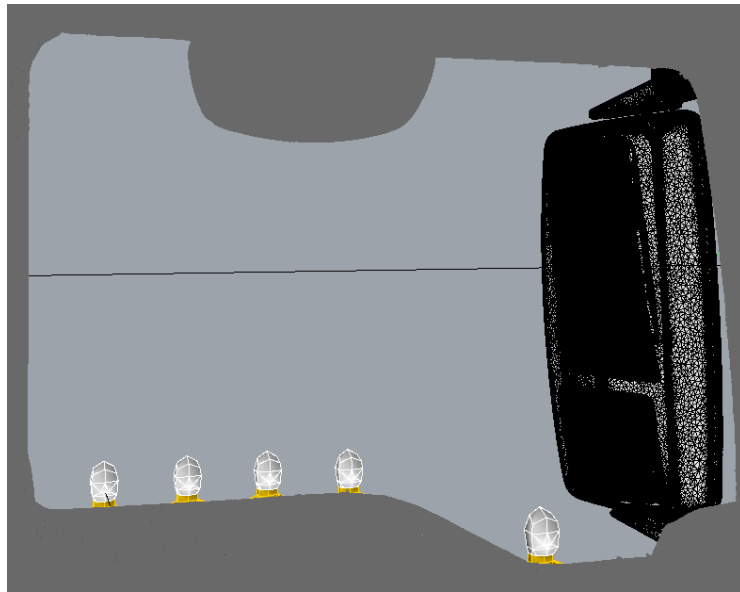
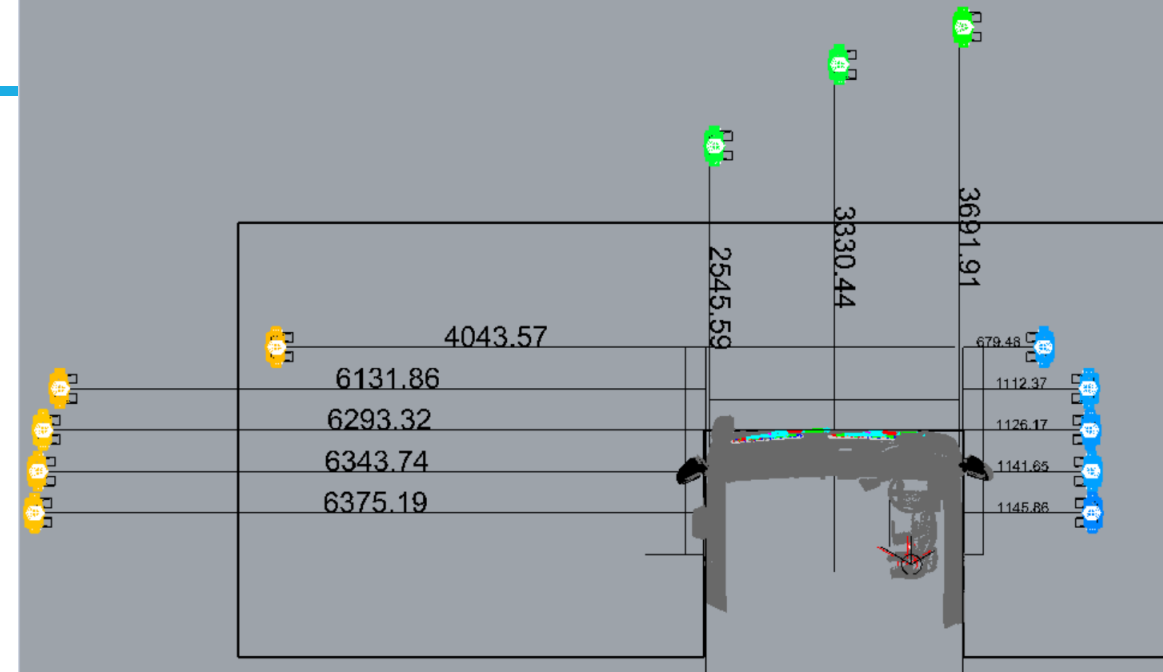

# EXAMPLE VRU DISTANCE RESULT

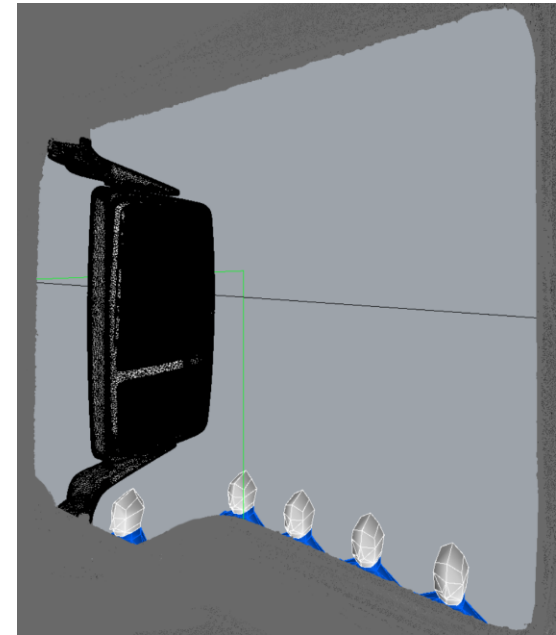
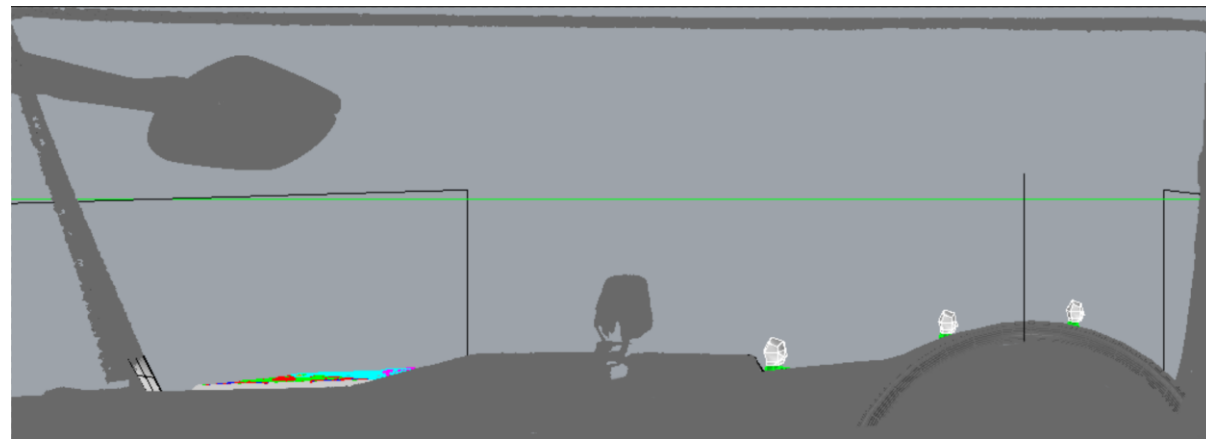
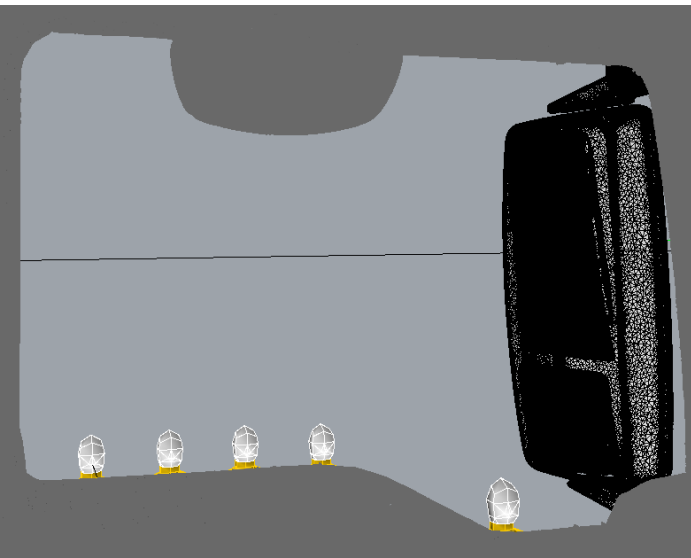
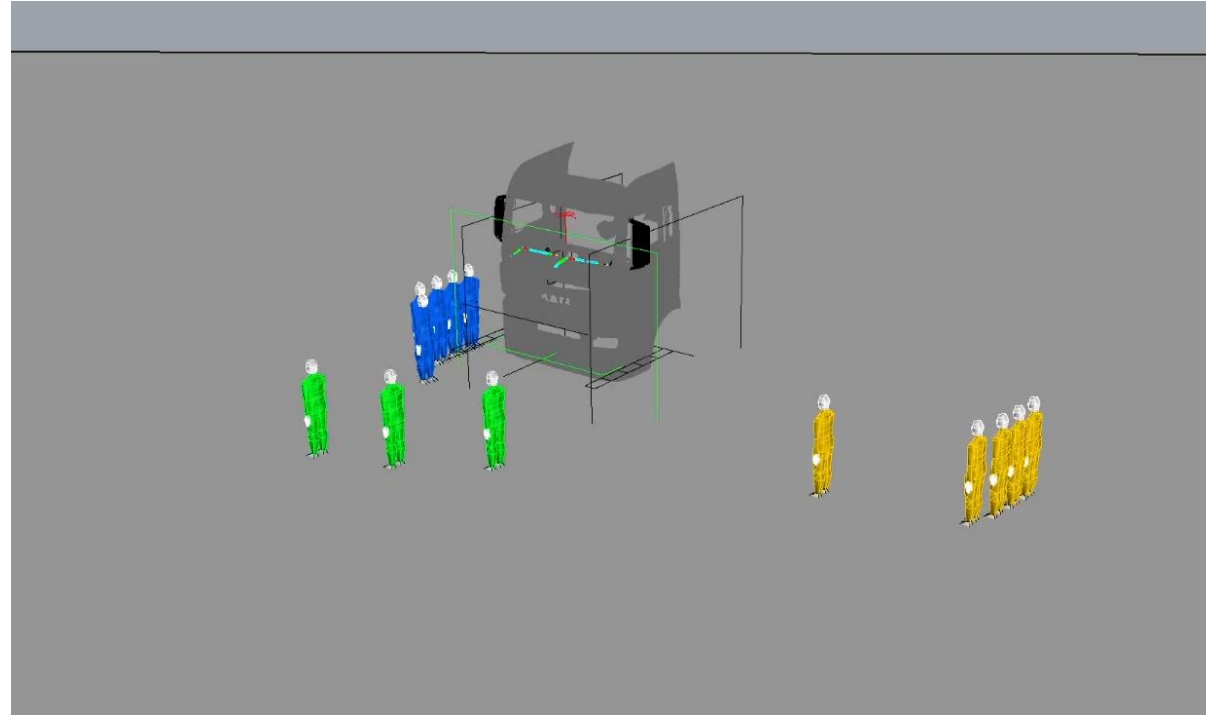

## SETTING THE TFL DVS MINIMUM REQUIREMENT

- The performance of the existing vehicle designs in 2018 was worse than anticipated
- A minimum requirement was required for the TfL Version, and then a grading system from 1 star to 5 star where 5 star is the best performing
- The minimum requirement was that no vehicle should allow VRUs to be in a blind spot between direct vision through windows and indirect vision through mirrors
- This requirement was a huge compromise due to the poor performance of many designs
- **ANY YET more than half of the vehicles tested were not able to meet this minimum requirement**

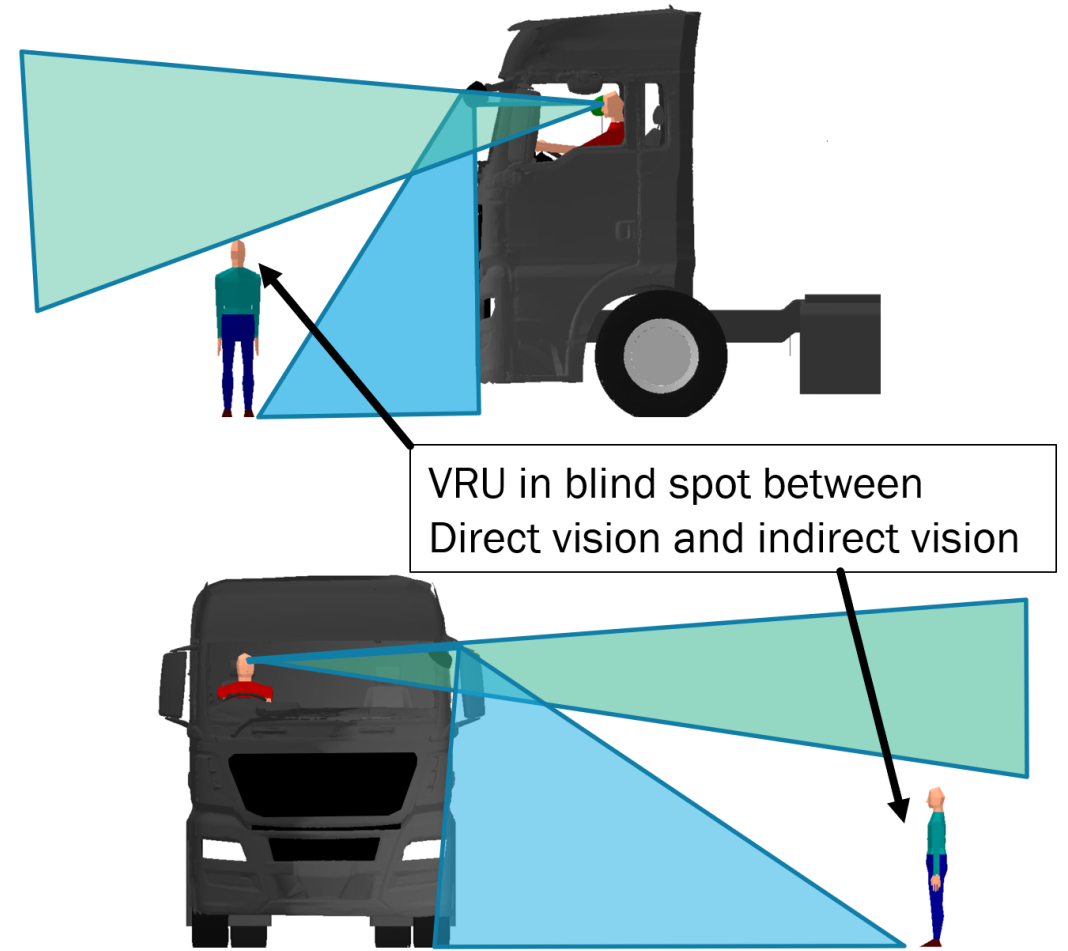

# EXAMPLE VRU DISTANCES FOR VEHICLES IN THE STAR BOUNDARY CATEGORIES (NEW VERSION, HEAD & NECK ONLY VISIBLE) TFL VERSION

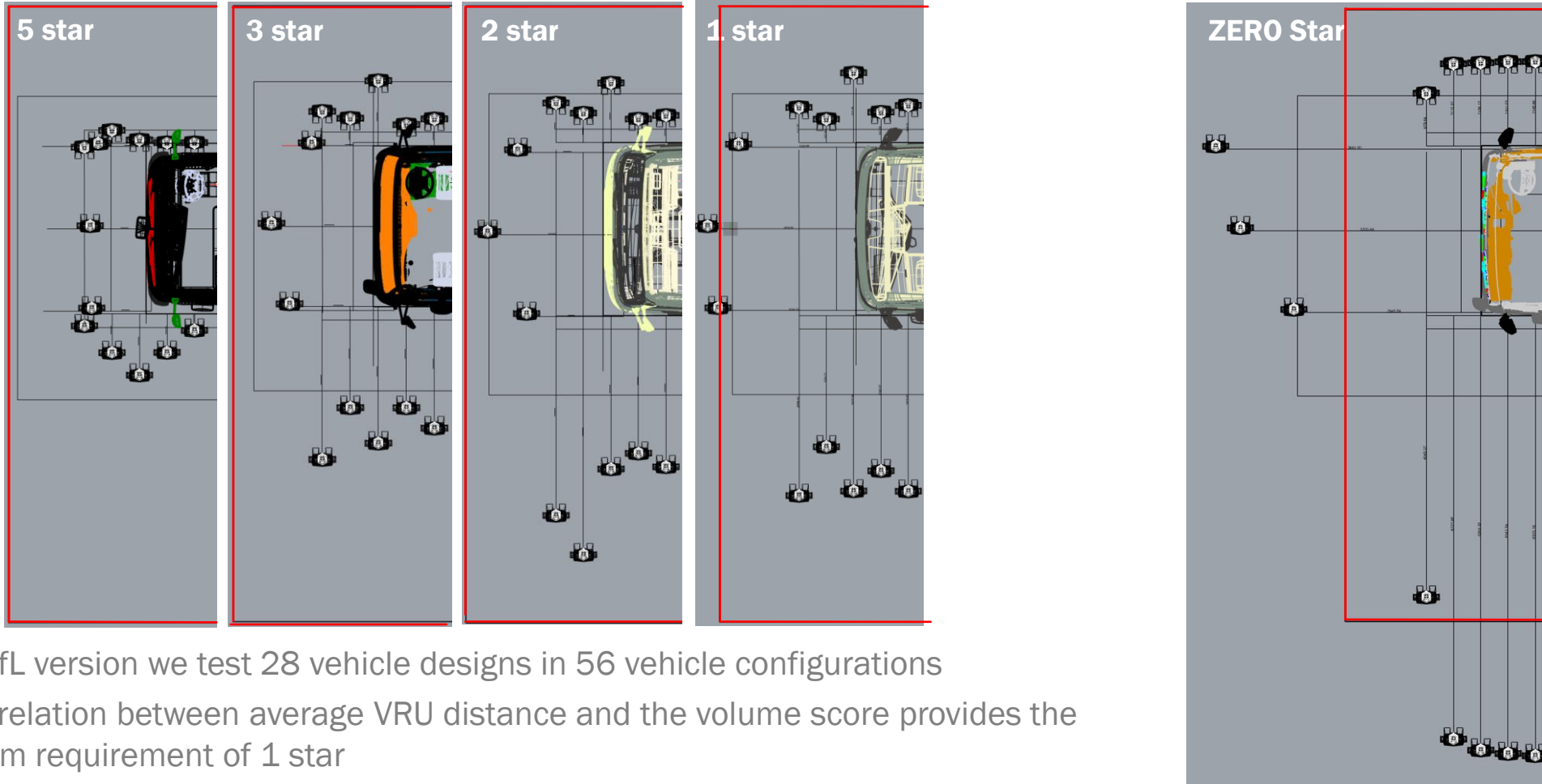

- In the TfL version we test 28 vehicle designs in 56 vehicle configurations
- The correlation between average VRU distance and the volume score provides the minimum requirement of 1 star



# EXAMPLE VRU DISTANCES FOR VEHICLES IN THE STAR BOUNDARY CATEGORIES (NEW VERSION, HEAD & NECK ONLY VISIBLE) TFL VERSION

TfL 5 star – Excellent

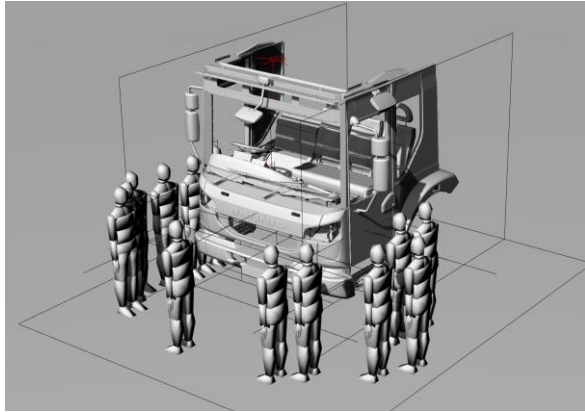

TfL 3 star – Good

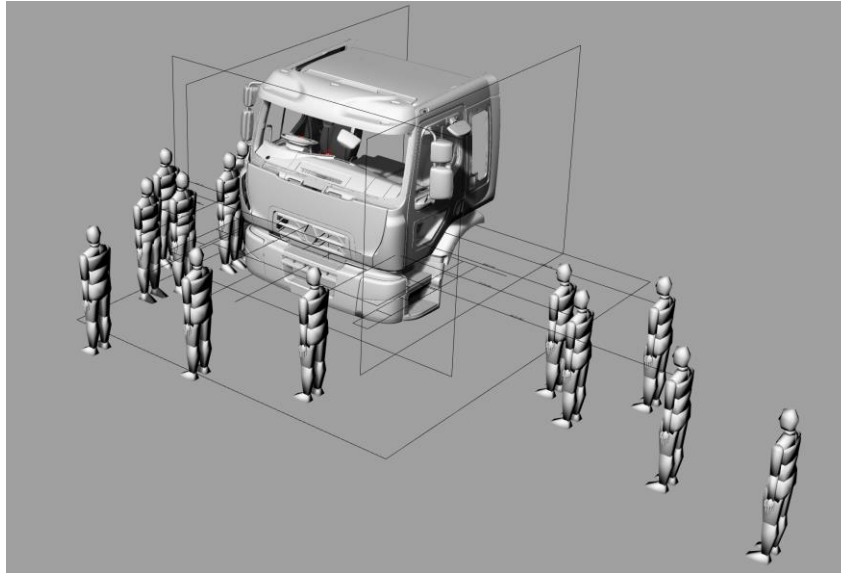

TfL 1 star – pass

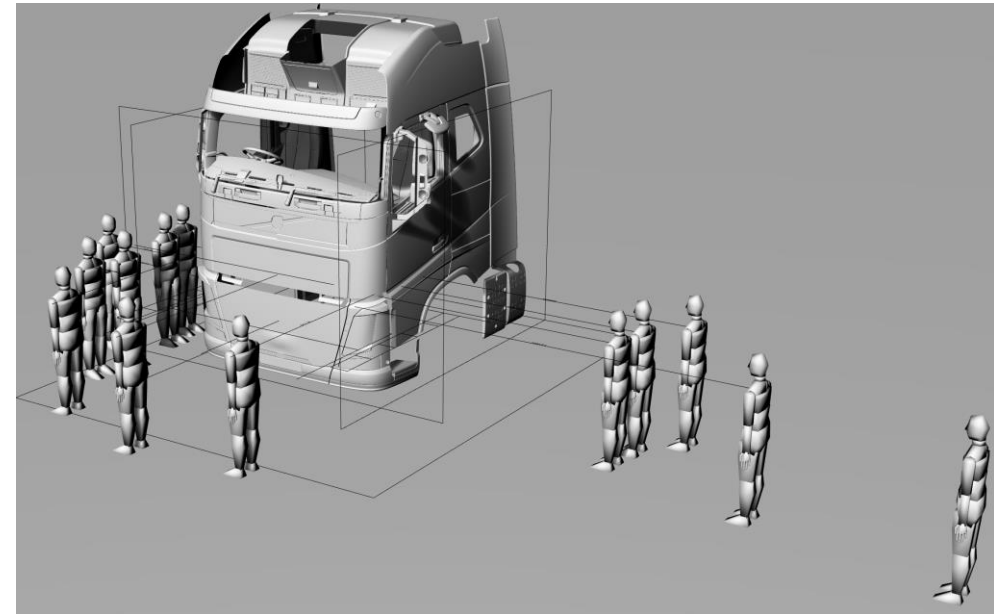

# EXAMPLE VRU DISTANCES FOR VEHICLES IN THE STAR BOUNDARY CATEGORIES (NEW VERSION, HEAD & NECK ONLY VISIBLE) TFL VERSION

TfL 5 star – Excellent

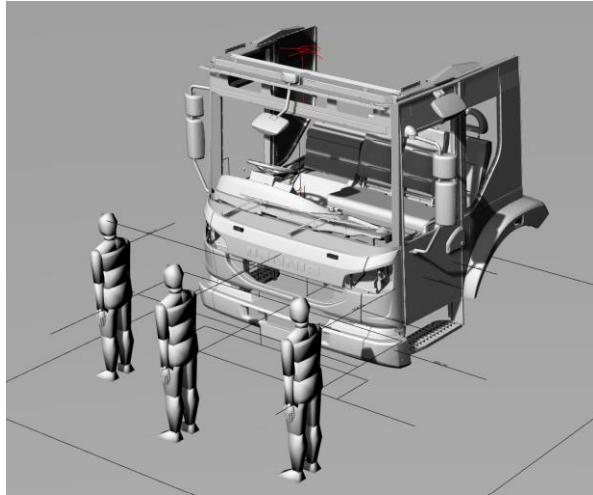

- Average VRU distance to the front = <1m

TfL 3 star – Good

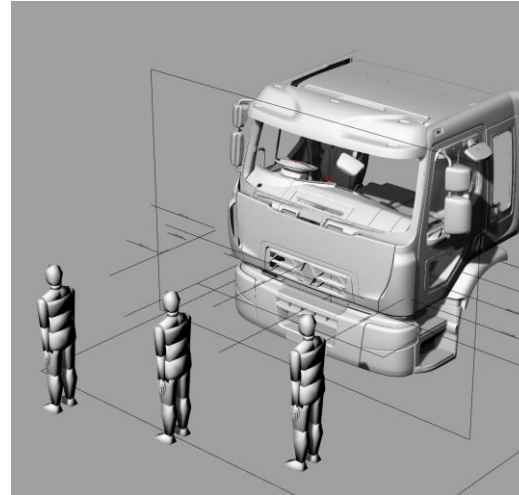

- Average VRU distance to the front = 1.6m

TfL 1 star – pass

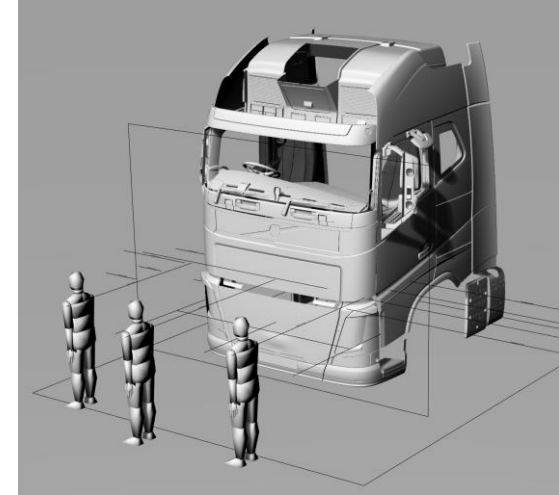

- Average VRU distance to the front = 1.9m

- A better performing vehicle allows the VRUs to be seen closer to the vehicle, reducing the size of the blindspot

# EXAMPLE VRU DISTANCES FOR VEHICLES IN THE STAR BOUNDARY CATEGORIES

(NEW)

Chart Visibility of head and neck

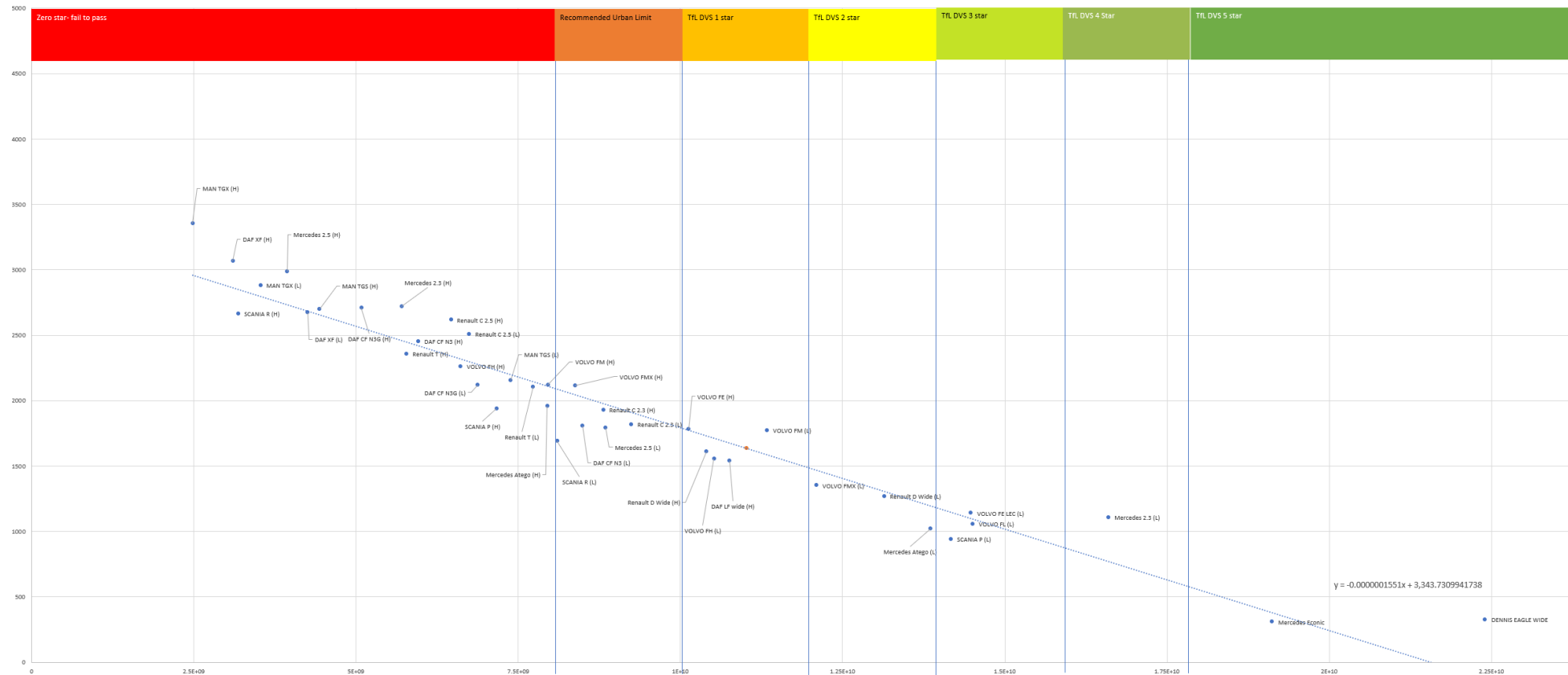

- In the TfL version we test 28 vehicle designs in 56 vehicle configurations
- The correlation between average VRU distance and the volume score provides the minimum requirement of 1 star



---

How the standard has been improved for the UNECE version with a separated approach



## HOW THE STANDARD HAS EVOLVED IN THE UNECE VERSION

- The standard is largely the same as the London version with some key differences as this standard is not rating existing vehicles, but supporting the improved design of vehicles for direct vision
- It was noted that it would be possible for manufacturers to improve the volumetric performance by simply improving the vision to the side to meet minimum requirements when using the same method as London
  - By removing mirrors, lowering passenger and driver window lines and adding lower door windows.
  - This meant the difference between passing and failing the minimum requirement
- This results in no improvement in safety to the front of the vehicle and still allows the blind spots between direct vision and indirect vision
- Therefore a **separated approach** was defined which requires minimum performance to the front and sides of the vehicle
- **The minimum frontal volume was DEFINED by the need to see VRUs directly in front of the vehicle at a distance that was within the indirect vision zone, REMOVING the blindspot**

## PROBLEMS WITH THE NEW VERSION

- The new version (option 3 or option 4) once again allows manufacturers to gain volume by making changes to the **side of the vehicle** and this means that the original method in the current standard and the amendment version are not equivalent
- This can be demonstrated in the example below, in both cases the 3 VRUs directly in front of the cab are in a blind spot between direct vision and indirect vision

### Original method in the standard - Front

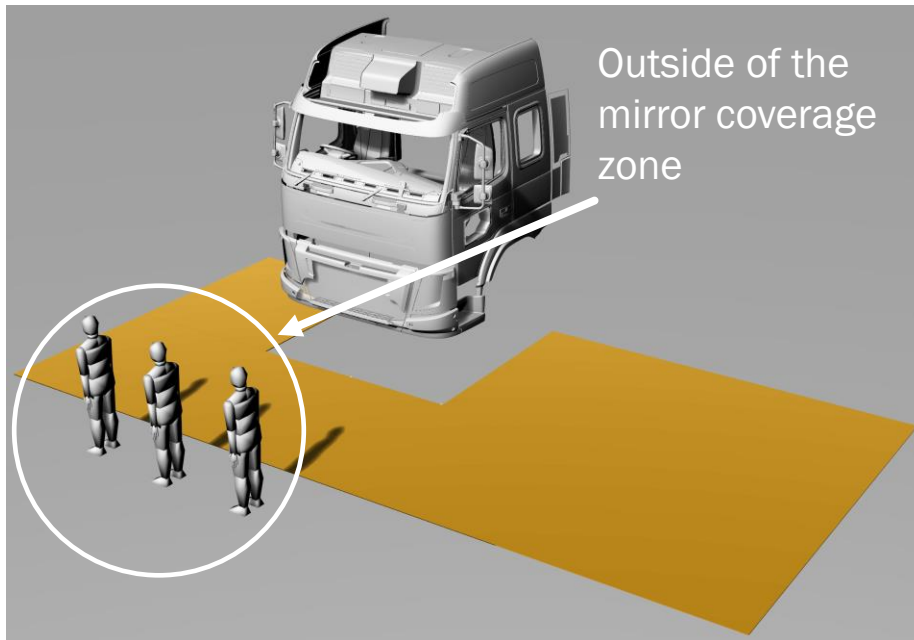

The vehicle **fails** the minimum requirement to the front and must be improved – e.g. lowered overall – lower windscreen and dashboard

### Amendment version - Option 3 method - Front

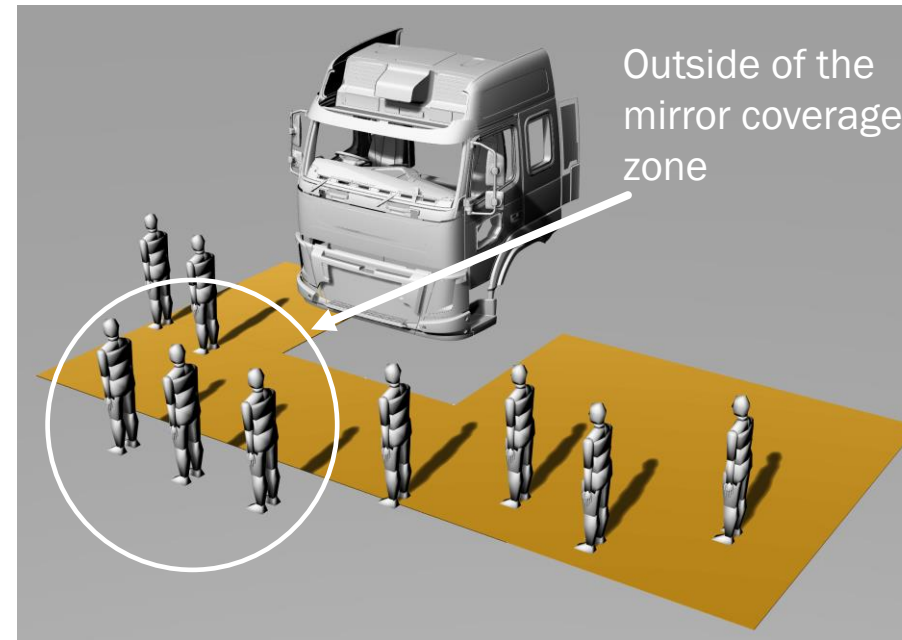

This vehicle fails the minimum requirement to the front and must be improved – manufacturers can gain volume by removing mirrors, lowering window edges and can then pass

**NO improvement to frontal direct vision blind spots**



## PRECEDENT FOR IMPROVING VEHICLE SCORE BY IMPROVING THE SIDE PERFORMANCE

- The TfL DVS method produced a score for the Volvo FM which meant that it not could achieve a three star rating.
- In 2024 3 star becomes the minimum requirement
- The TfL DVS does not take the separated approach (this was developed for the UNECE version)
- Volvo therefore redesigned their truck to improve direct vision to the sides only to improve the design





## PRECEDENT FOR IMPROVING VEHICLE SCORE BY IMPROVING THE SIDE PERFORMANCE

- If we overlay the new and old designs we can see that the new design (yellow path) has a lower edge for the passenger window allowing more volume to be seen to the side
- The red path shows the old design

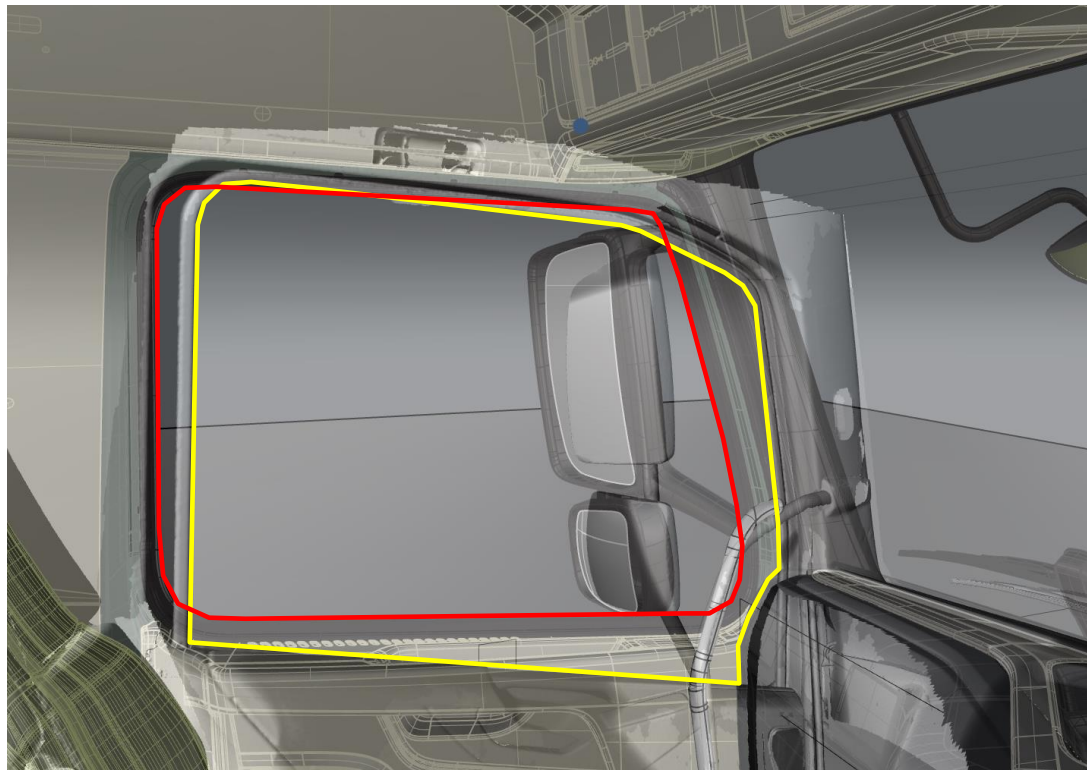





## PRECEDENT FOR IMPROVING VEHICLE SCORE BY IMPROVING THE SIDE PERFORMANCE

- The TfL DVS method produced a score for the Volvo FM which meant that it not could achieve a three star rating.
- In 2024 3 star becomes the minimum requirement
- The TfL DVS does not take the separated approach (this was developed for the UNECE version)
- Volvo therefore redesigned their truck to improve direct vision to the sides only to improve the design



## PRECEDENT FOR IMPROVING VEHICLE SCORE BY IMPROVING THE SIDE PERFORMANCE

- If we overlay the new and old designs we can see that the new design (yellow path) has the same dashboard height. Therefore front VRU distance will be the same, no improvement to front direct vision.
- Other improvements were narrower A-Pillars, reduced obscuration by the mirror housings.

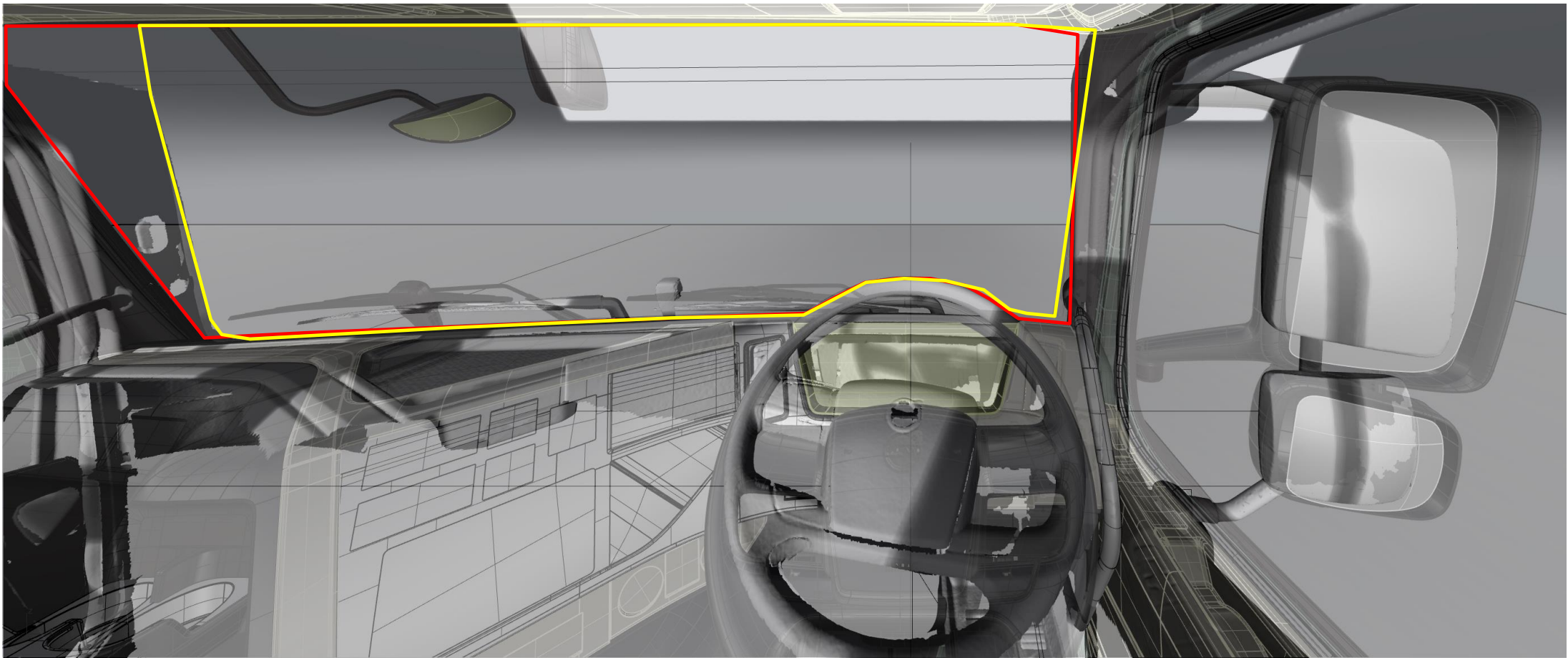



# MOVING FORWARD

- We are not saying that Volvo did anything wrong, they simply improved the design by the rules allowed in the TfL version of the DVS
- The issue that we are highlighting is that this can also be done with the current version of the amendment standard
- We need a way to ensure that the results are equivalent (with some tolerance) and this is not currently the case
- We would like to work with Johan Broeders and Michael Kneissle to address this issue