



THE DESIGN OF THE UNECE HGV DVS FOR TECH NEUTRAL CAB DESIGN

EQUIVALENCE BETWEEN THE EXISTING METHOD AND PROPOSED AMENDMENT

DR STEVE SUMMERSKILL, PROF. RUSSELL MARSHALL, DR ABBY PATERSON, ANTHONY ELAND

FUNDED BY THE ROAD SAFETY TRUST



CONTENT

- How the DVS was defined for the London version
- How the standard has been improved for the UNECE version with a separated approach
- Problems with the new version
- Ways forward



HOW THE DVS WAS DEFINED FOR THE LONDON VERSION

- The London (Transport for London) version of the DVS was defined to provide a method which allows an accurate measure of direct vision, which is quantified using a real world measure of direct vision performance, VRU distance
- The accurate measure of Direct vision takes the form of the amount of an assessment volume that can be seen from a standardised eye point
- The real world measure is the distance at which VRU simulations can be seen by the driver

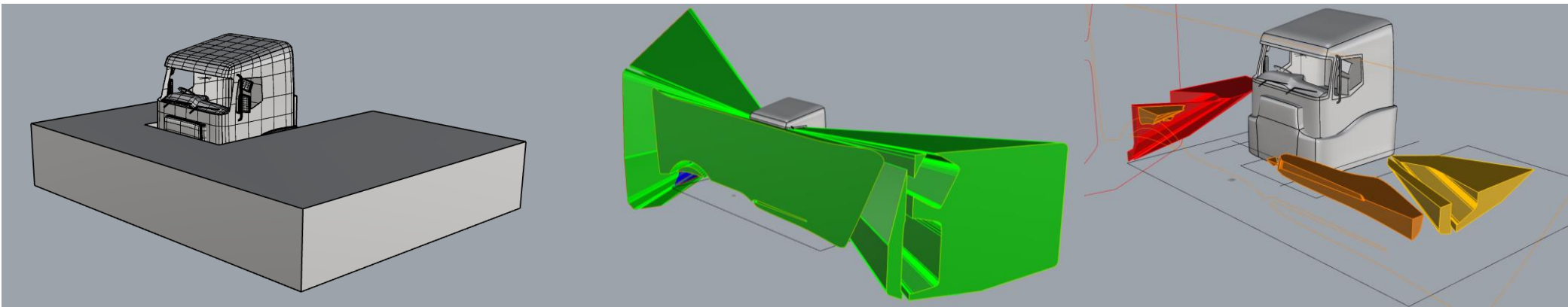

HOW ARE THE VRU SIMULATIONS DEFINED AND USED

- As per the diagram, an array of VRU simulations is arranged around the vehicle using a consistent method. Each VRU is then moved away from the side of the truck in one axis only
- The portion of the VRU that must be visible was originally proposed as head and shoulders but head and neck is now agreed
- This is followed by example results for the VRU distances

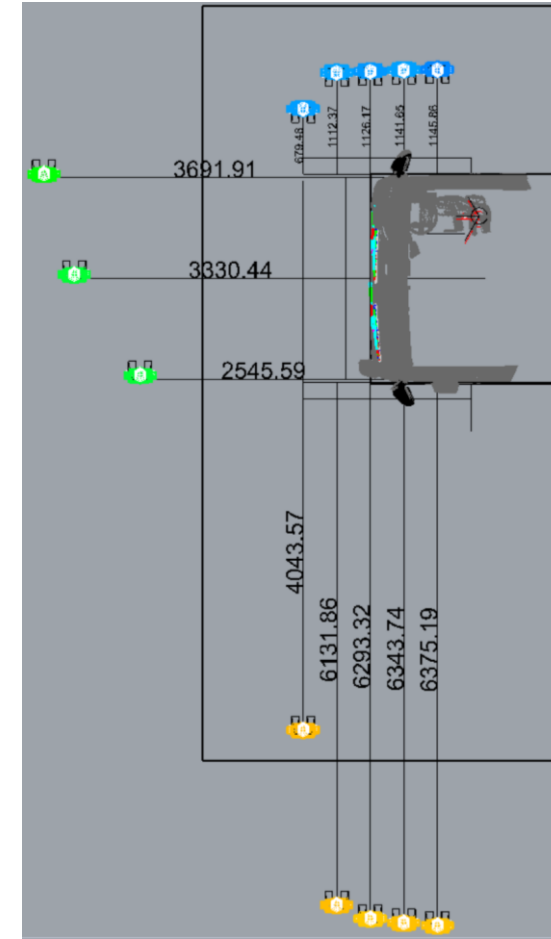
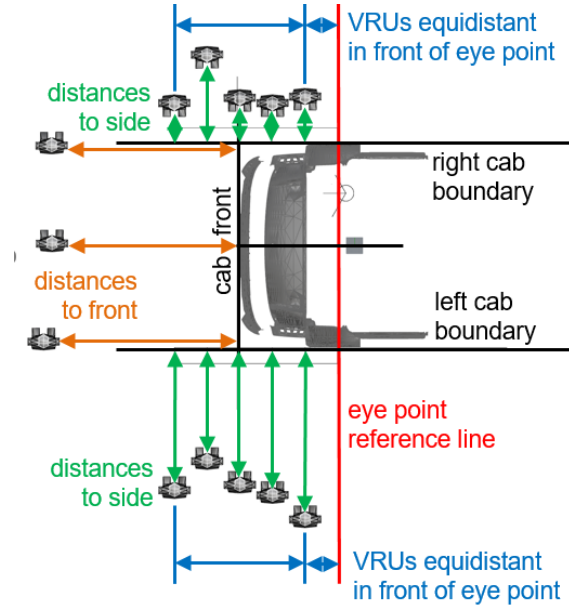

²COOK, S., SUMMERSKILL, S., MARSHALL, R., ... et al., 2011. The development of improvements to drivers' direct and indirect vision from vehicles - phase 2. Report for Department for Transport DfT TTS Project Ref: S0906 / V8. Loughborough: Loughborough University and MIRA Ltd. **See section 2.5** <https://hdl.handle.net/2134/8873>

³SUMMERSKILL, S. Marshall, R; Paterson, A; Reed, S (2015): Understanding direct and indirect driver vision in heavy goods vehicles. Report. <https://hdl.handle.net/2134/21028>



EXAMPLE VRU DISTANCE RESULT

- The bottom images shows the placement of the VRU simulations to the front and sides of the vehicle for **head and neck visibility from the simulated eyepoint**.
- Top right shows a plan view of VRU positions

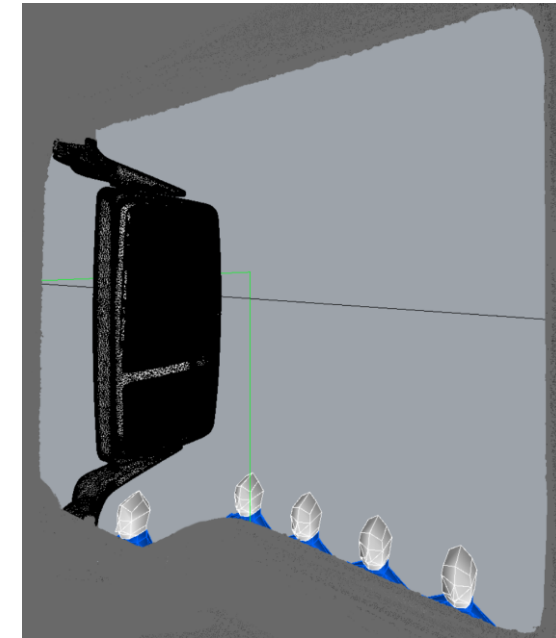
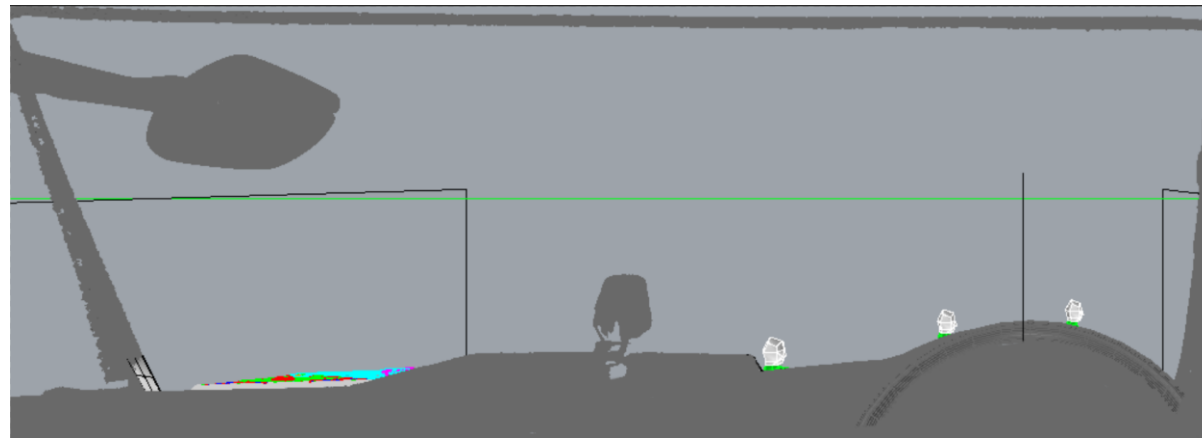
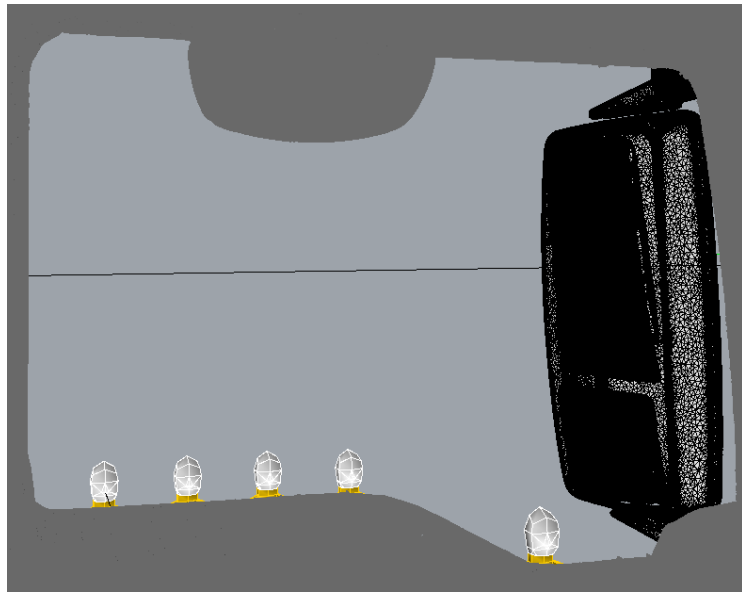
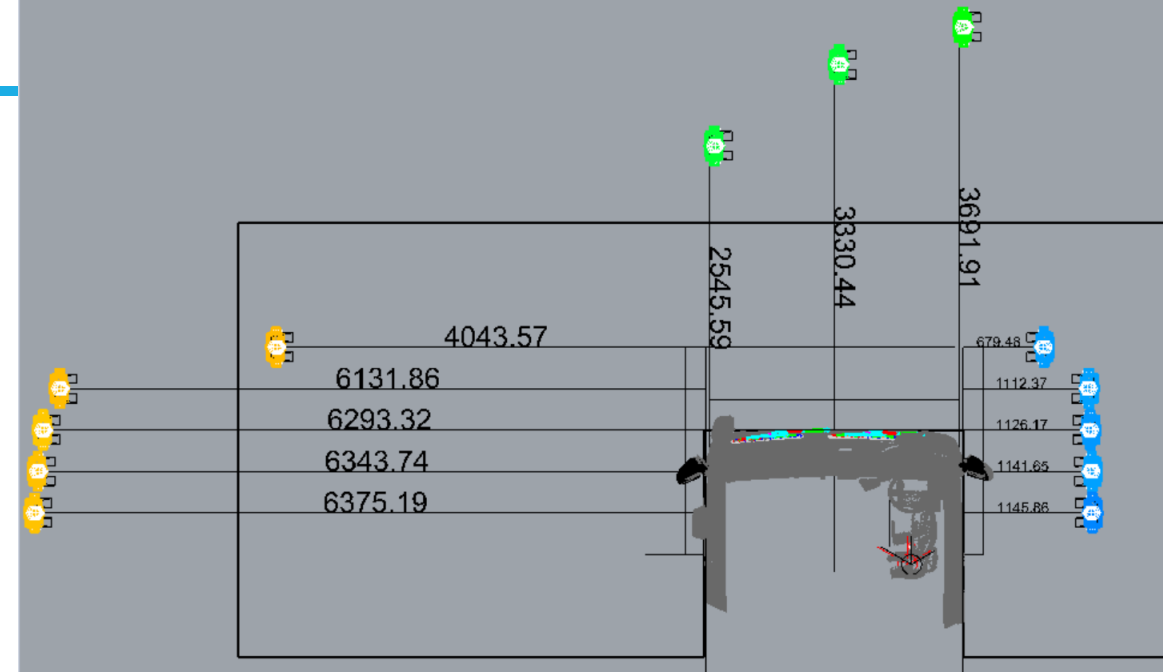

EXAMPLE VRU DISTANCE RESULT

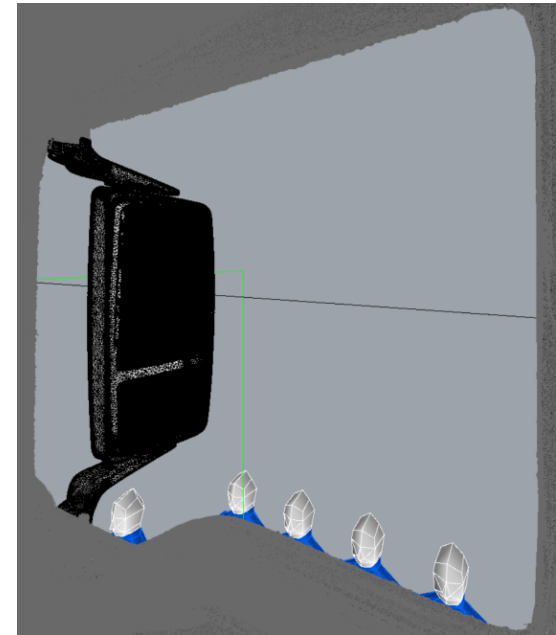
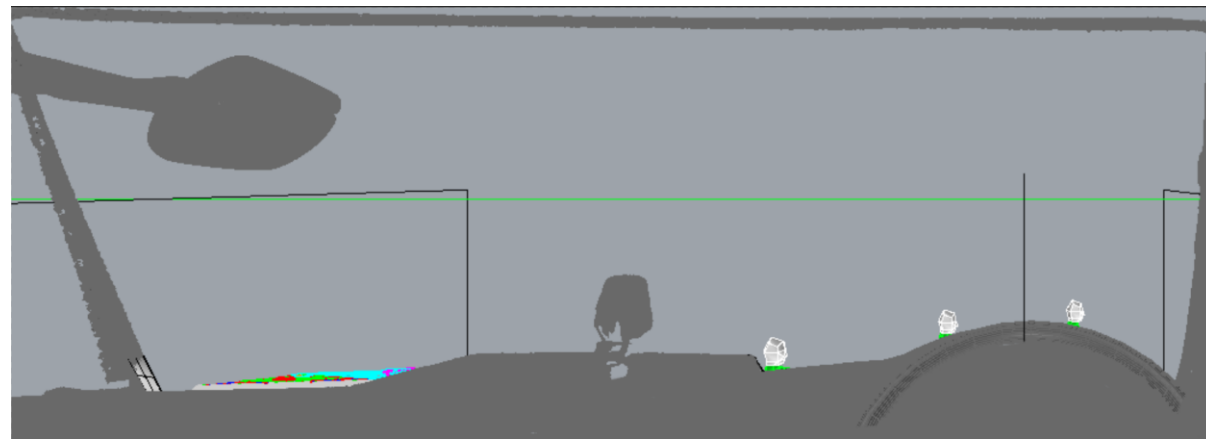
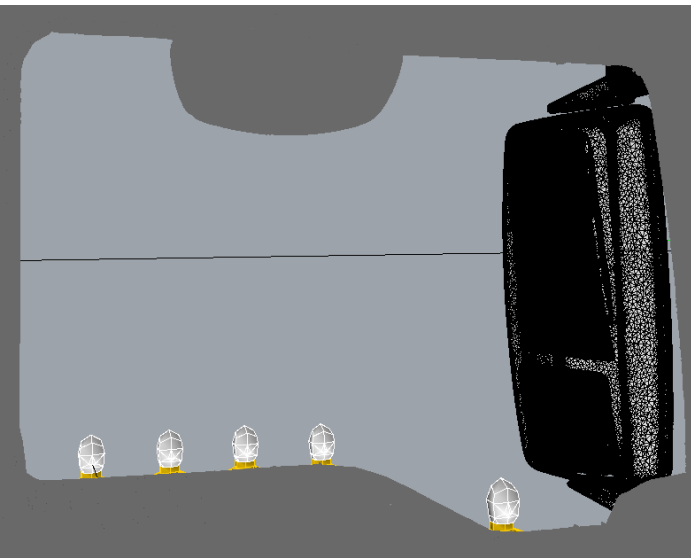
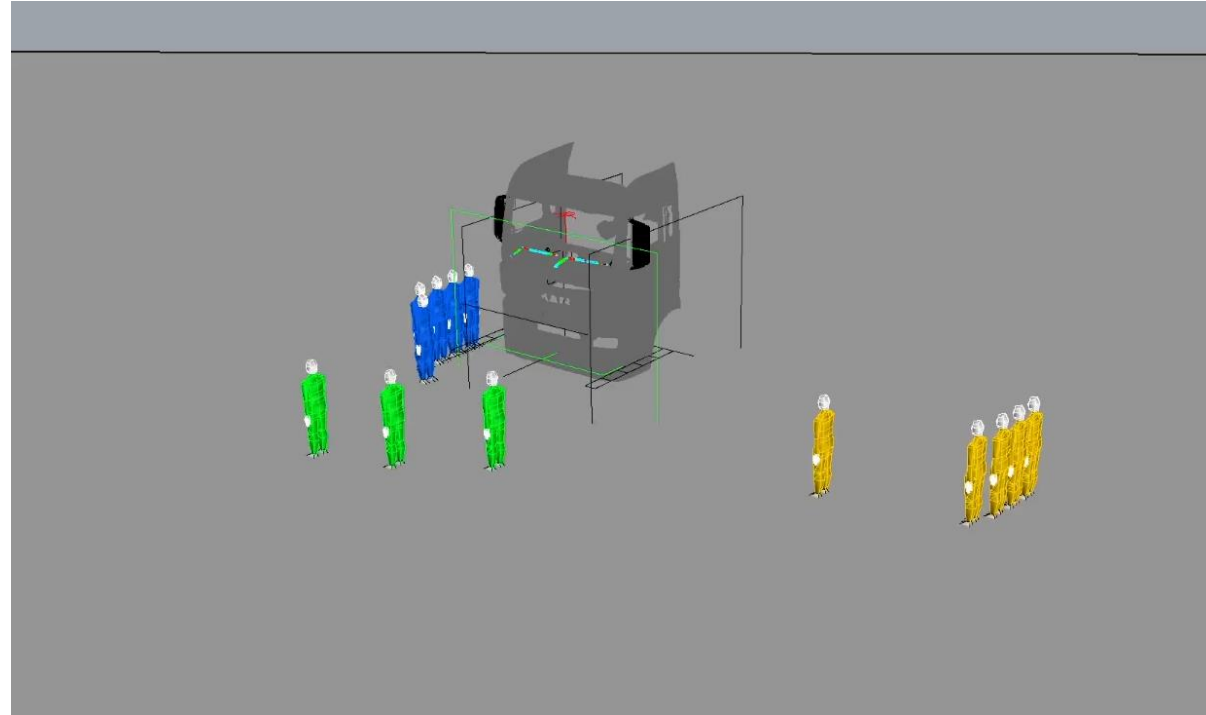

SETTING THE TFL DVS MINIMUM REQUIREMENT

- The performance of the existing vehicle designs in 2018 was worse than anticipated
- A minimum requirement was required for the TfL Version, and a grading system from 1 star to 5 star where 5 star is the best performing
- The minimum requirement was that no vehicle should allow VRUs to be in a blind spot between direct vision through windows and indirect vision through mirrors
- This requirement was a huge compromise due to the poor performance of many designs
- **AND YET more than half of the vehicles tested were not able to meet this minimum requirement**

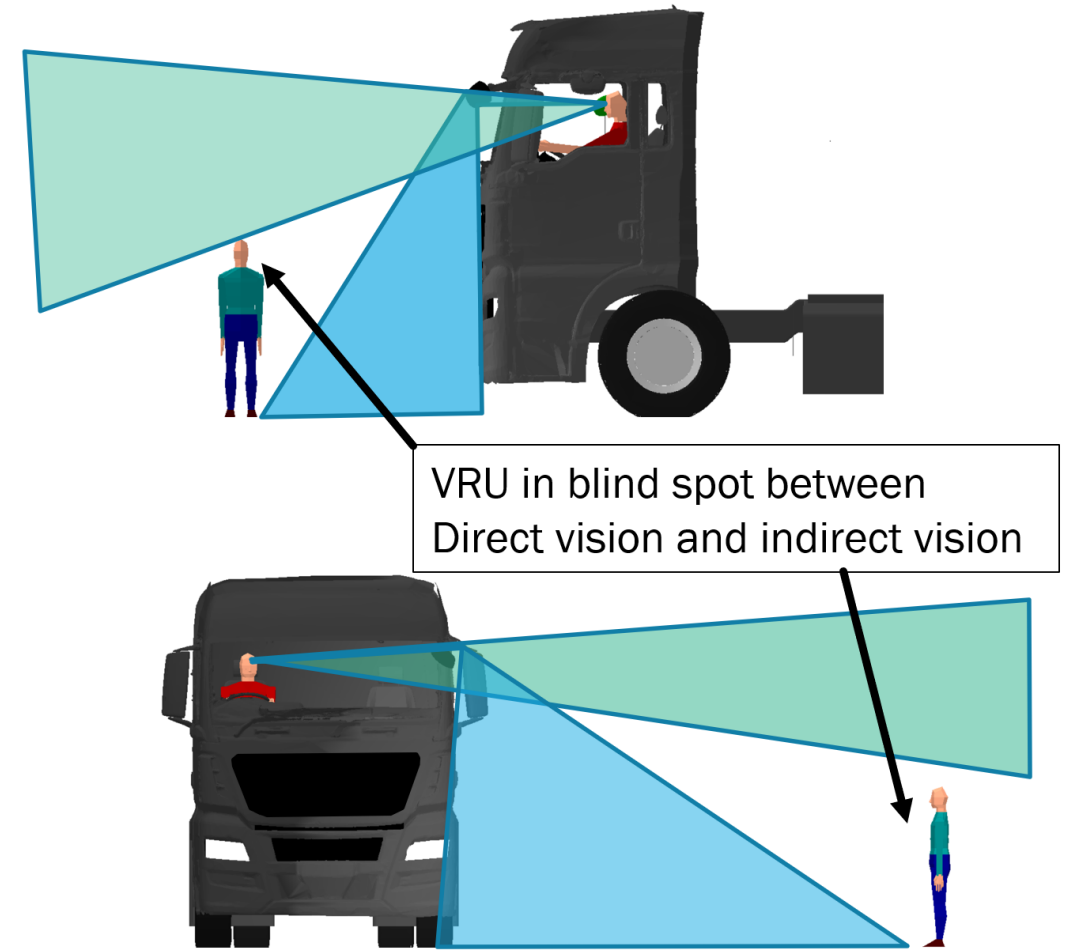

EXAMPLE VRU DISTANCES FOR VEHICLES IN THE STAR BOUNDARY CATEGORIES (NEW VERSION, HEAD & NECK ONLY VISIBLE) TFL VERSION

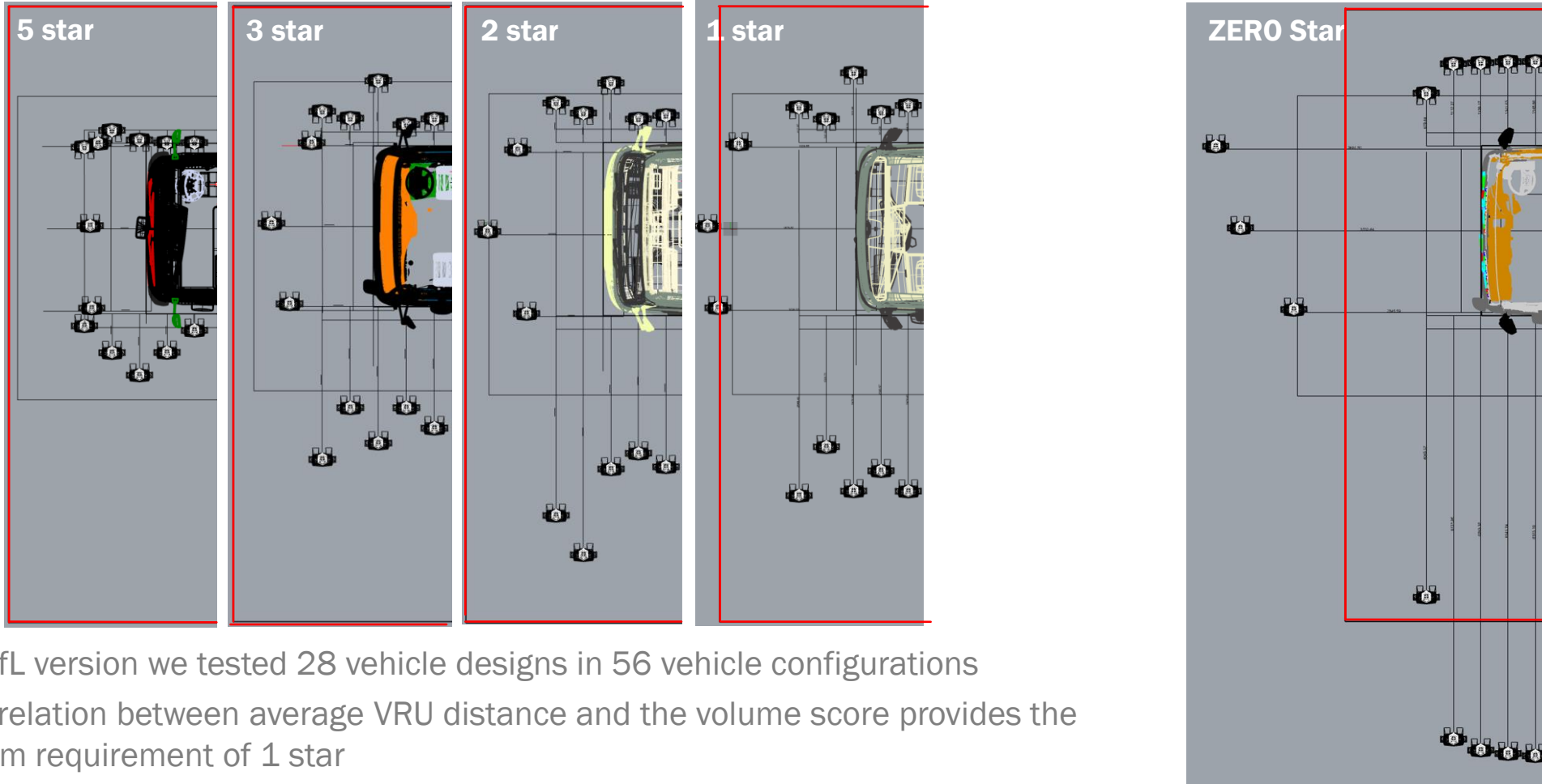

- In the TfL version we tested 28 vehicle designs in 56 vehicle configurations
- The correlation between average VRU distance and the volume score provides the minimum requirement of 1 star

EXAMPLE VRU DISTANCES FOR VEHICLES IN THE STAR BOUNDARY CATEGORIES (NEW VERSION, HEAD & NECK ONLY VISIBLE) TFL VERSION

TfL 5 star – Excellent

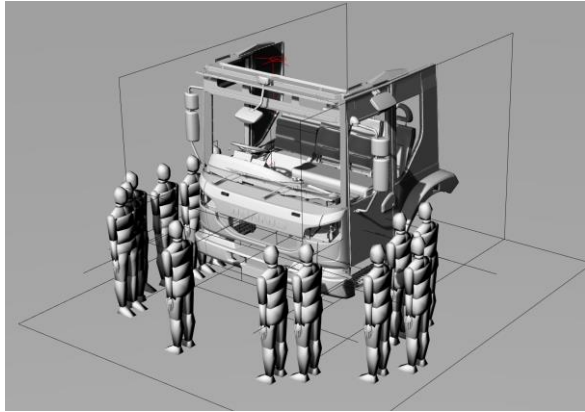

TfL 3 star – Good

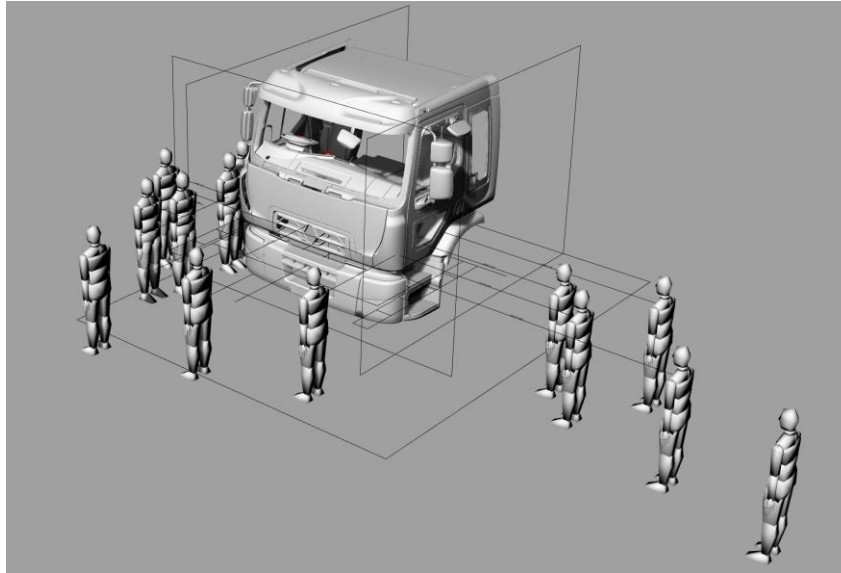

TfL 1 star – pass

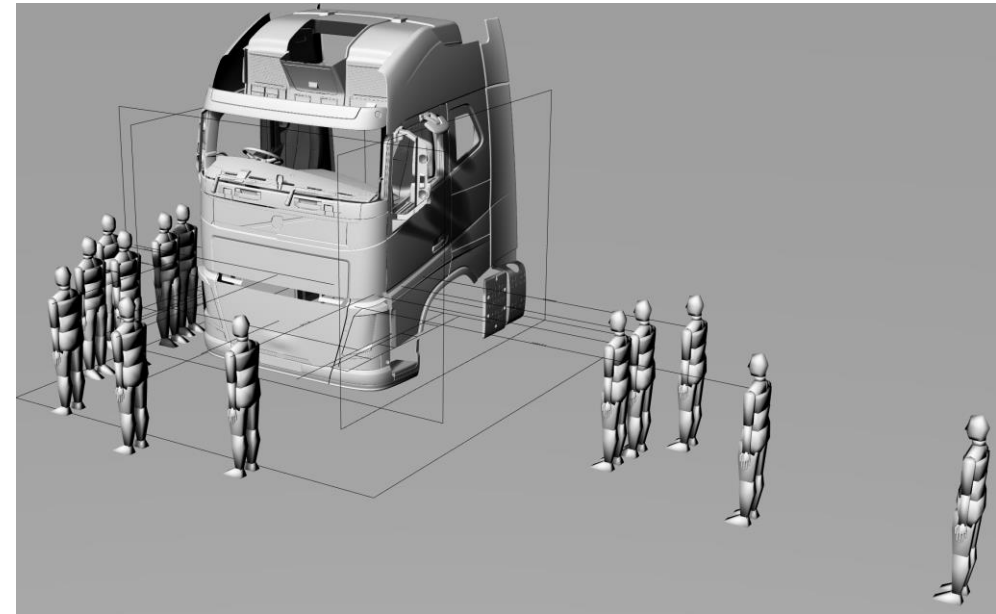

EXAMPLE VRU DISTANCES FOR VEHICLES IN THE STAR BOUNDARY CATEGORIES (NEW VERSION, HEAD & NECK ONLY VISIBLE) TFL VERSION

TfL 5 star – Excellent

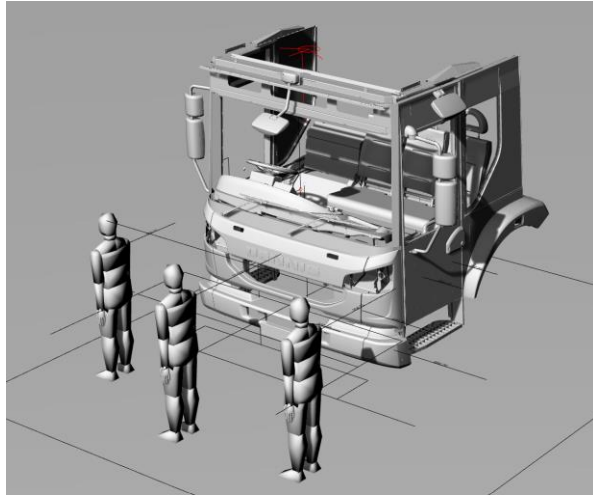

- Average VRU distance to the front = <1m

TfL 3 star – Good

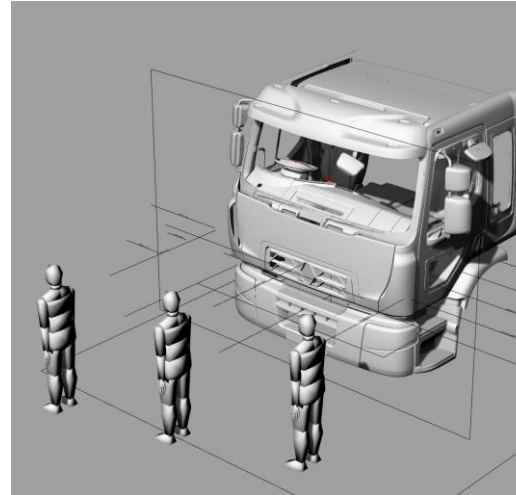

- Average VRU distance to the front = 1.6m

TfL 1 star – pass

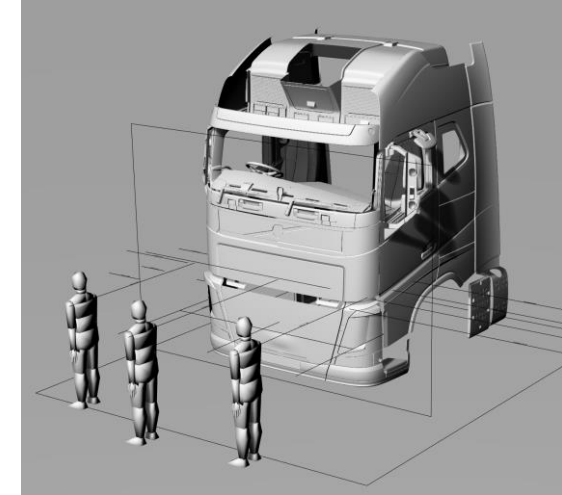

- Average VRU distance to the front = 1.9m

- A better performing vehicle allows the VRUs to be seen closer to the vehicle, reducing the size of the blindspot

EXAMPLE VRU DISTANCES FOR VEHICLES IN THE STAR BOUNDARY CATEGORIES

(NEW)

Chart Visibility of head and neck

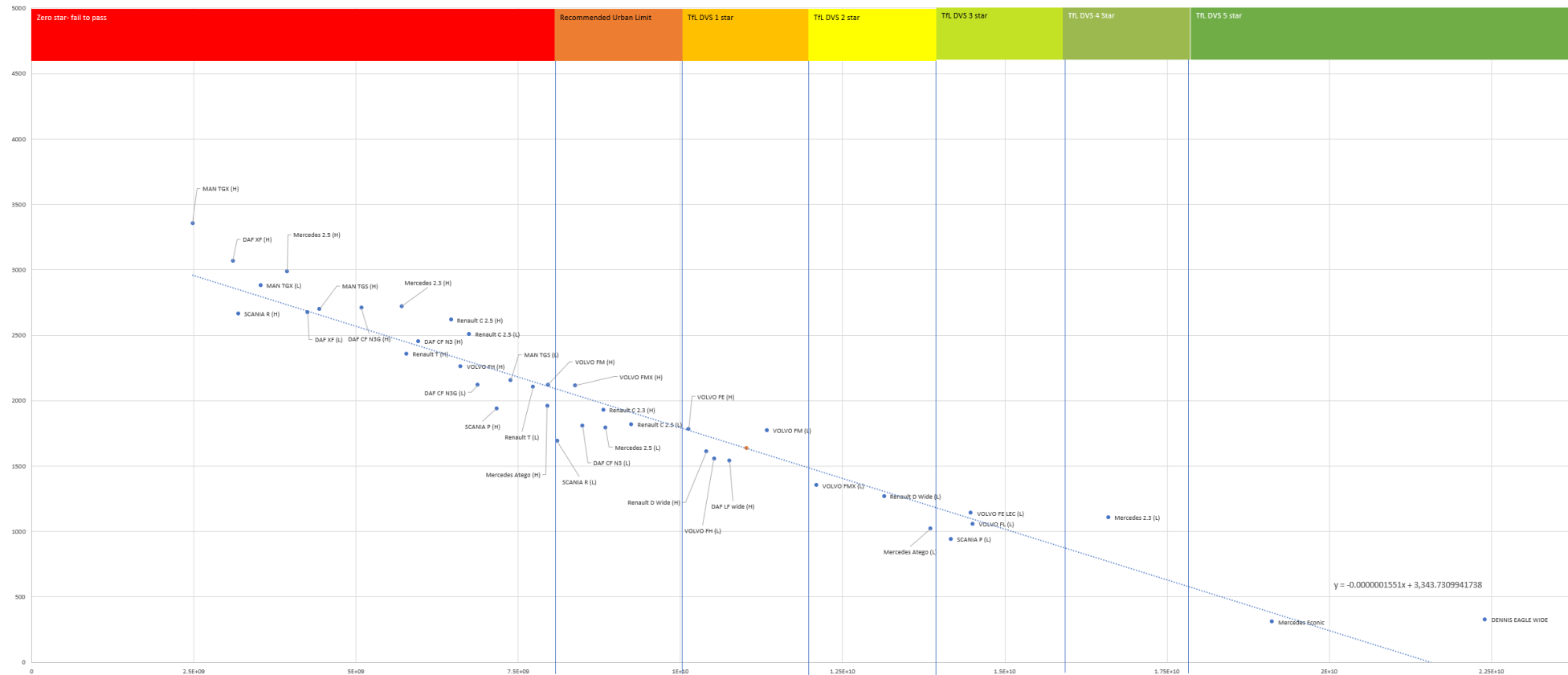

- In the TfL version we tested 28 vehicle designs in 56 vehicle configurations
- The correlation between average VRU distance and the volume score provides the minimum requirement of 1 star



How the standard has been improved for the UNECE version with a separated approach



HOW THE STANDARD HAS EVOLVED IN THE UNECE VERSION

- The standard is largely the same as the London version with some key differences as this standard is not rating existing vehicles, but supporting the improved design of vehicles for direct vision
- Our analysis showed that it would be possible for manufacturers to improve the volumetric performance by simply improving the vision to the side, to meet minimum requirements when using the same method as London
 - By removing mirrors, lowering passenger and driver window lines and adding lower door windows.
 - These are relatively easy changes to make compared to removing internal components from a Dashboard to allow redesign
 - This meant the difference between passing and failing the minimum requirement
- This results in no improvement in safety to the front of the vehicle and still allows the blind spots between direct vision and indirect vision
- Therefore a **separated approach** was defined which requires minimum performance to the front and sides of the vehicle
- **The minimum frontal volume was DEFINED by the need to see VRUs directly in front of the vehicle at a distance that was within the indirect vision zone, REMOVING the blind spot**

PROBLEMS WITH THE NEW VERSION

- The new version (option 3 or option 4) once again allows manufacturers to gain volume by making changes to the **side of the vehicle** and this means that the original method in the current standard and the amendment version **are not equivalent**
- This can be demonstrated in the example below, in both cases the 3 VRUs directly in front of the cab are in a blind spot between direct vision and indirect vision

Original method in the standard - Front

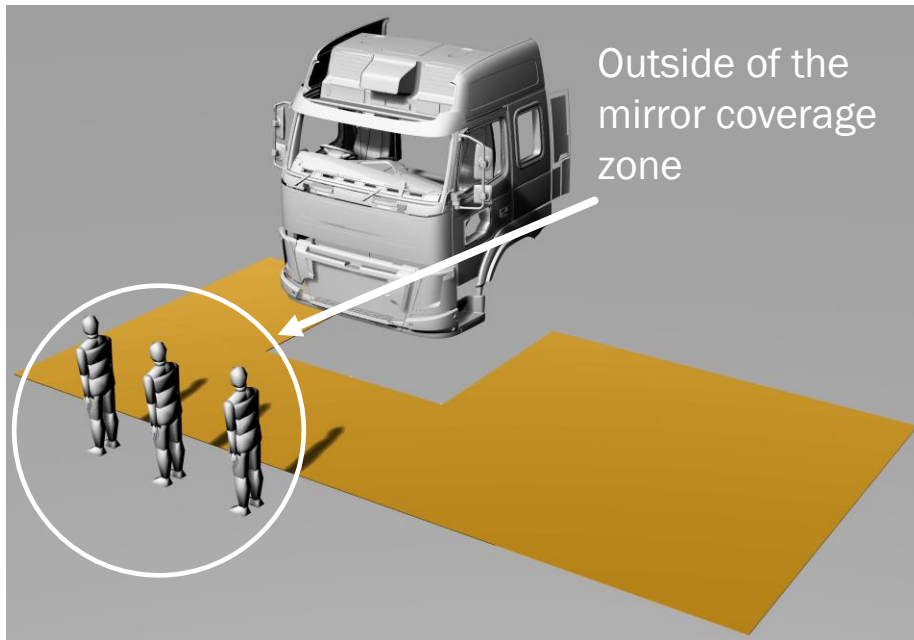

The vehicle **fails** the minimum requirement to the front and must be improved – e.g. lowered overall – lower windscreen and dashboard

Amendment version - Option 3 method - Front

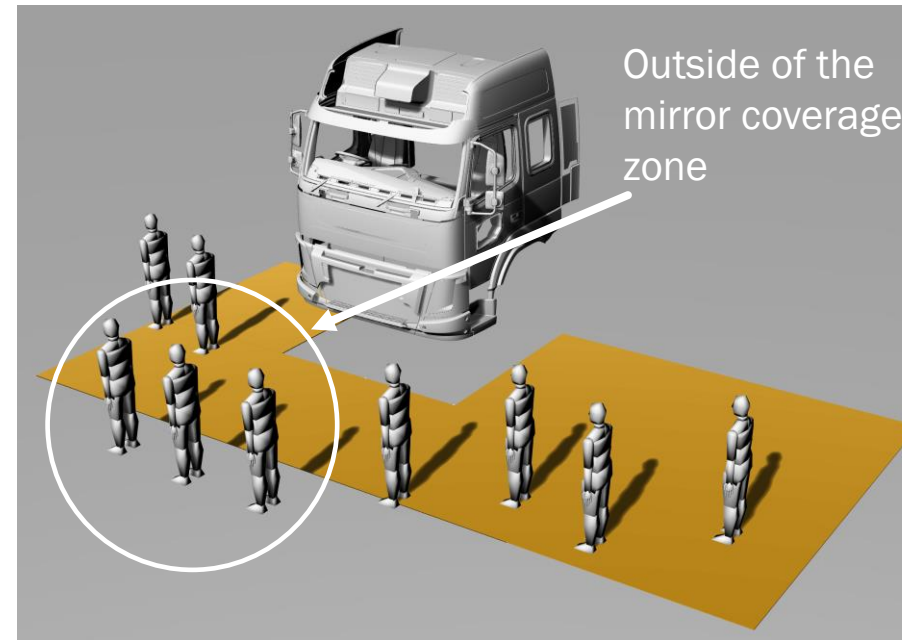

The vehicle fails the minimum requirement to the front and must be improved – however manufacturers can gain volume by improving performance to the sides and not the front in this version and can then pass **NO improvement to frontal direct vision blind spots**



ACCIDENTOLOGY

- The analysis of accident data performed in the DVS TfL project using UK STATS 19 data highlighted that;
- 32% of 'Killed or Seriously Injured' accidents are at the front of the vehicle, with the majority being pedestrians over the age of 65 in moving off from rest scenarios (e.g. at a pedestrian crossing).
- It is our view that an unaltered new version would do less to improve this situation
- To provide context, 42% of the vehicles tested have an average VRU distance to the front beyond 2m



PRECEDENT FOR IMPROVING VEHICLE SCORE BY IMPROVING THE SIDE PERFORMANCE

- The TfL DVS method produced a score for the Volvo FM which meant that it not could achieve a three star rating.
- In 2024 3 star becomes the minimum requirement
- The TfL DVS does not take the separated approach (this was developed for the UNECE version)
- Volvo therefore redesigned their truck to improve direct vision to the sides only to improve the design



PRECEDENT FOR IMPROVING VEHICLE SCORE BY IMPROVING THE SIDE PERFORMANCE

- If we overlay the new and old designs we can see that the new design (yellow path) has a lower edge for the passenger window allowing more volume to be seen to the side
- The red path shows the old design

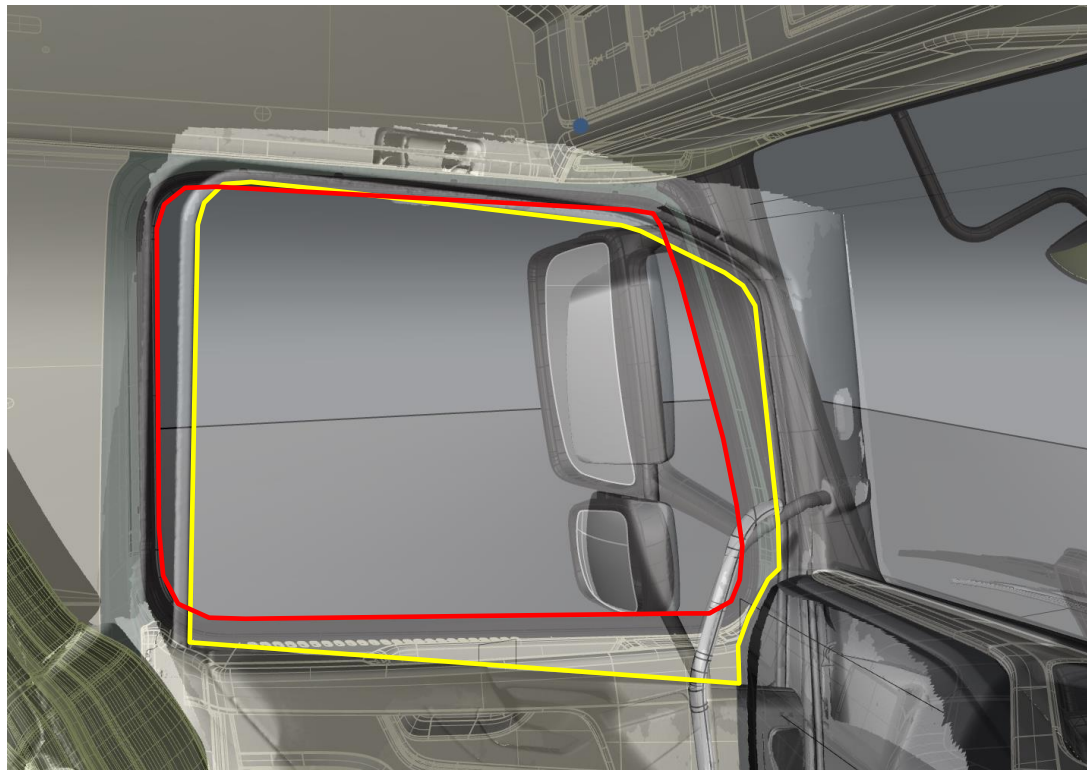

PRECEDENT FOR IMPROVING VEHICLE SCORE BY IMPROVING THE SIDE PERFORMANCE

- The TfL DVS method produced a score for the Volvo FM which meant that it not could achieve a three star rating.
- In 2024 3 star becomes the minimum requirement
- The TfL DVS does not take the separated approach (this was developed for the UNECE version)
- Volvo therefore redesigned their truck to improve direct vision to the sides only to improve the design





PRECEDENT FOR IMPROVING VEHICLE SCORE BY IMPROVING THE SIDE PERFORMANCE

- If we overlay the new and old designs we can see that the new design (yellow path) has the same dashboard height. Therefore front VRU distance will be the same, no improvement to front direct vision.
- Other improvements were narrower A-Pillars, reduced obscuration by the mirror housings.

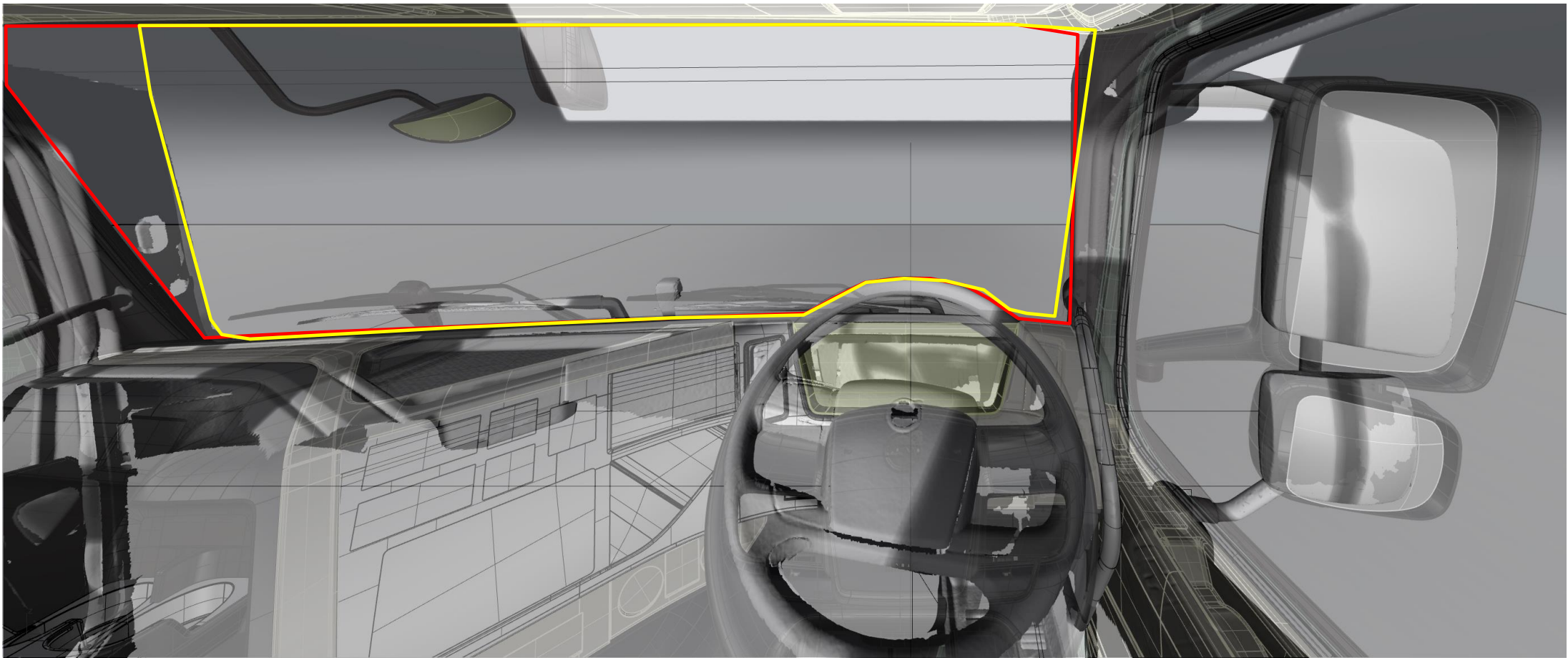



MOVING FORWARD

- We are not saying that Volvo did anything wrong, they simply improved the design by the rules allowed in the TfL version of the DVS
- The issue that we are highlighting is that this can also be done with the current version of the amendment standard
- We need a way to ensure that the results are equivalent (with some tolerance) and this is not currently the case
- This is a not new issue, we have been discussing it in various ways (e.g. last slide of presentation in the 26th meeting) but we think that the new method of explanation is clearer
- The next phase of work was always defined to ensure equivalence between the existing new methods
- We would like to work collectively to resolve the concerns raised