



30TH UNECE VRU PROXI GROUP: A- PILLAR DISTANCE MEASUREMENT AND REDUCTION IN VOLUME BY A-PILLAR DISTANCE

DR STEVE SUMMERSKILL

CONTENT

- Reminder of discussion in last VRU proxi Meeting
- Task force meeting requirements
- Options for measuring A-pillar distance
- Results from testing volume required for reduced inter A-pillar distance.

REMINDER OF DISCUSSION IN LAST VRU PROXI MEETING

- In the last meeting it was agreed that we would explore how the volume requirements to the front of Level 1, 2 and 3 vehicles can be reduced with reduced A-pillar distance
- In future there may be vehicles which by design employ a smaller distance between the A-pillars than the cabs that were used to derive the standard then the volume
- In this situation the proposal is that these vehicles should be required to achieve a frontal volume that reduces proportionally with A-pillar distance

REQUIREMENTS DEFINED BY A SUBSEQUENT TASK FORCE MEETING

- A task force meeting was held to discuss the issues
- It was decided that we (LDS) would utilise the sample of data that have to explore the following issues
 - Which of two possible methods for measuring inter A-pillar distance is best?
 - The options for producing requirements for the volume that must be seen at different inter A-pillar distances

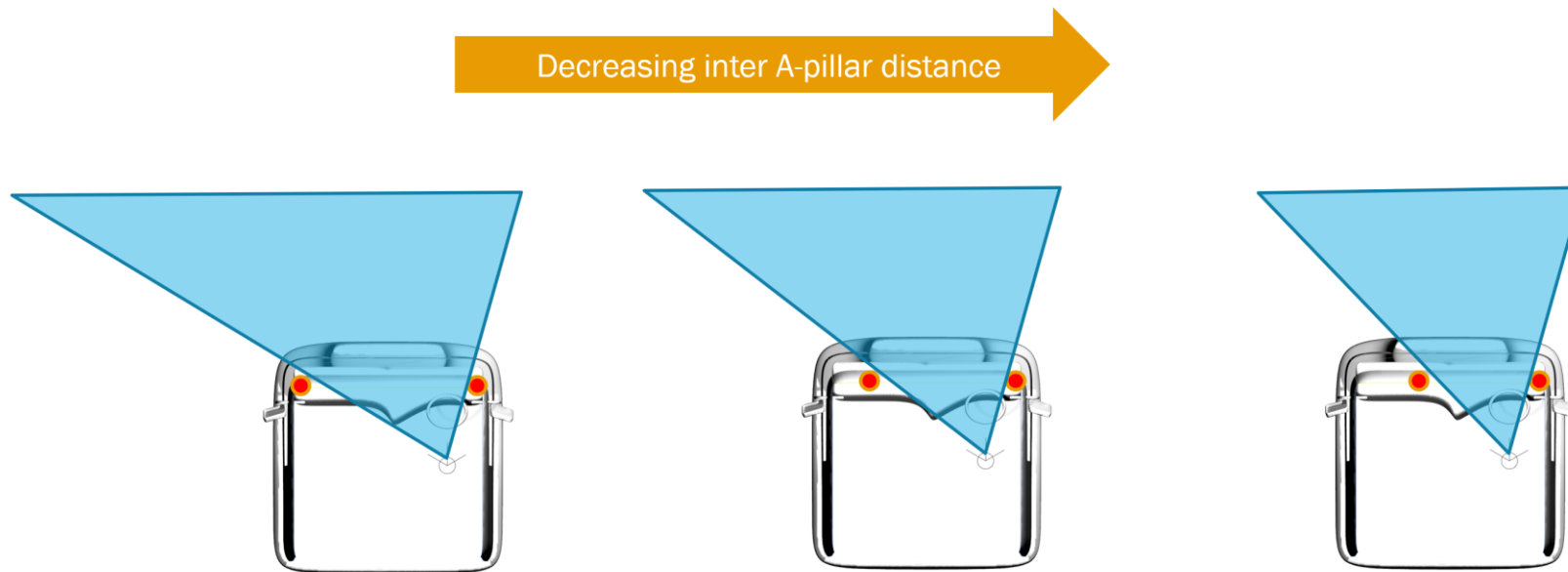

TWO POSSIBLE METHODS FOR MEASURING INTER A-PILLAR DISTANCE

- Method 1 = shortest distance between A-pillars in the Y-Axis at the DVS eye point height
- Method 2 = distance between A – pillars as seen from the driver's eye point

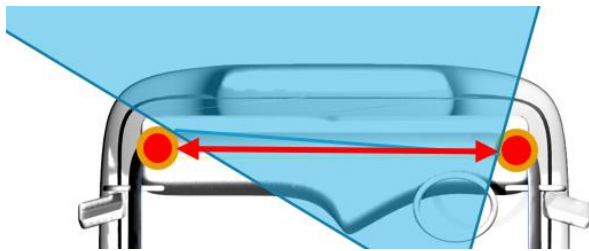

Y-Axis

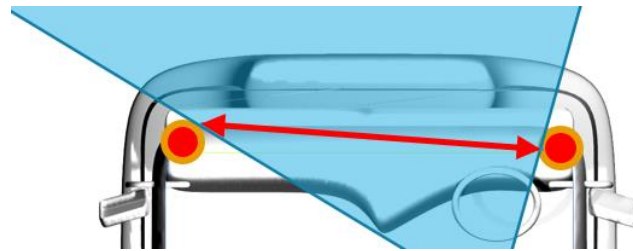

Distance as seen from eye point

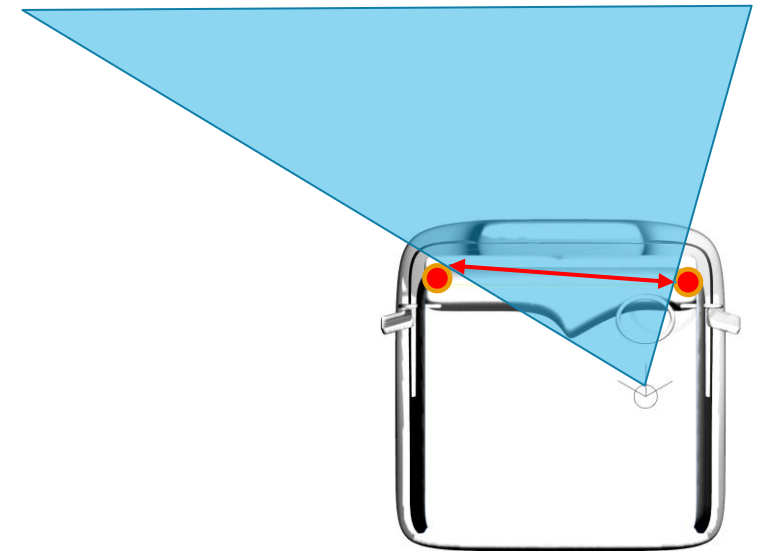
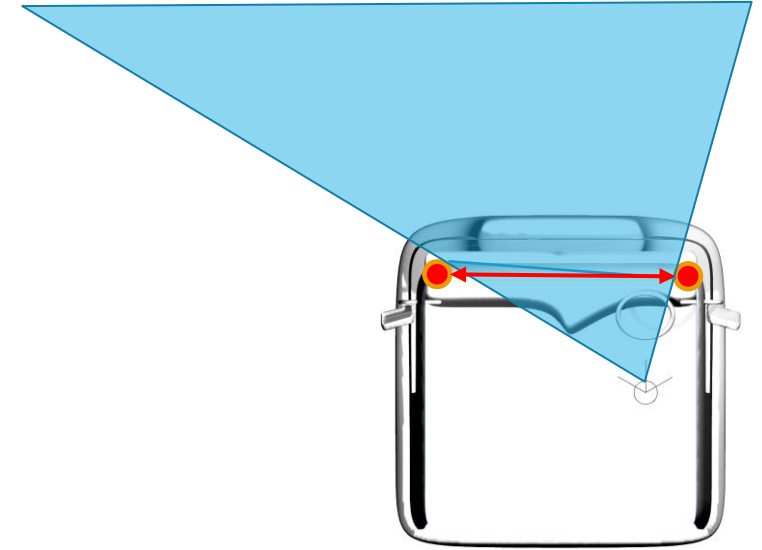

TWO POSSIBLE METHODS FOR MEASURING INTER A-PILLAR DISTANCE

- Results for two possible methods for measuring inter A-pillar distance

TWO POSSIBLE METHODS FOR MEASURING INTER A-PILLAR DISTANCE

- The two methods produce similar results with the inter a-pillar distance for the vehicles tested
- The bottom graph shows an example for one vehicle where the two methods produce linear results
- Hence, the A-pillar profile didn't vary the "as seen from eye point view" as much as anticipated.
- This is good. The simpler method is preferred.
- However future designs may be better assessed with the distance from the eye point

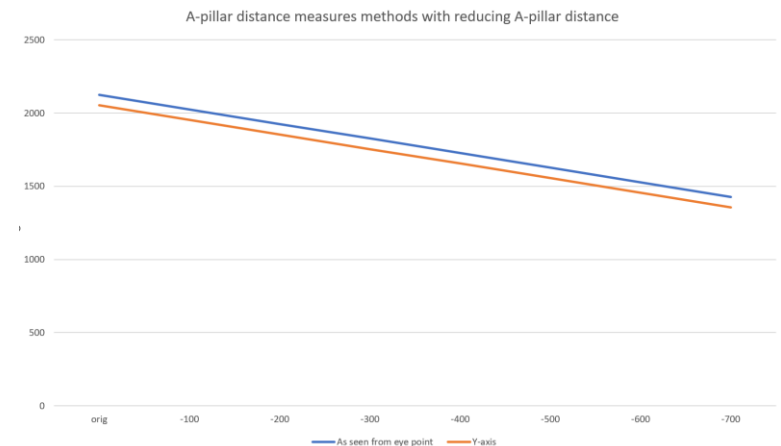
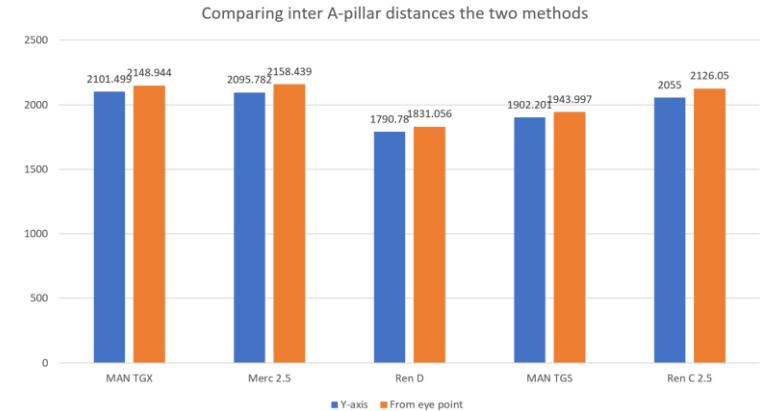

TESTING VOLUME REQUIRED FOR REDUCED INTER A-PILLAR DISTANCE.

- Testing volume required for reduced inter A-pillar distance.

TESTING VOLUME REQUIRED FOR REDUCED INTER A-PILLAR DISTANCE.

- In the last task force meeting we agreed to perform an analysis with the data that we have, to explore the volume that must be seen for reducing A-pillar width
- We have performed the following steps
- Selected a sample of vehicles that have differing dash board designs
 - MAN TGX, Daimler 2.5m cab, Volvo FMX, Renault C 2.5
- Found the height of the cabs where they meet the 1.8m³ volume requirement for Level 1 vehicles and the same for 1m³ Level 2/3 vehicles.
- Reduced the inter A-pillar distance in seven 100mm increments for all vehicles
- Plotted these data to generate the graph on the right

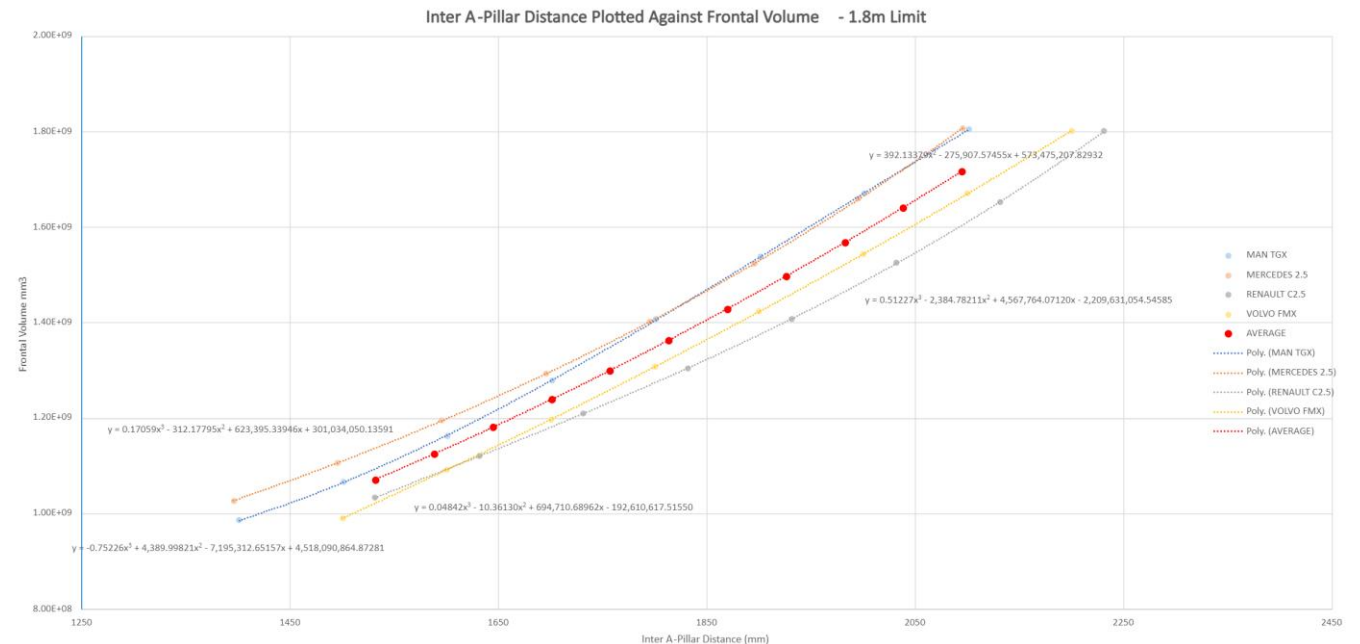
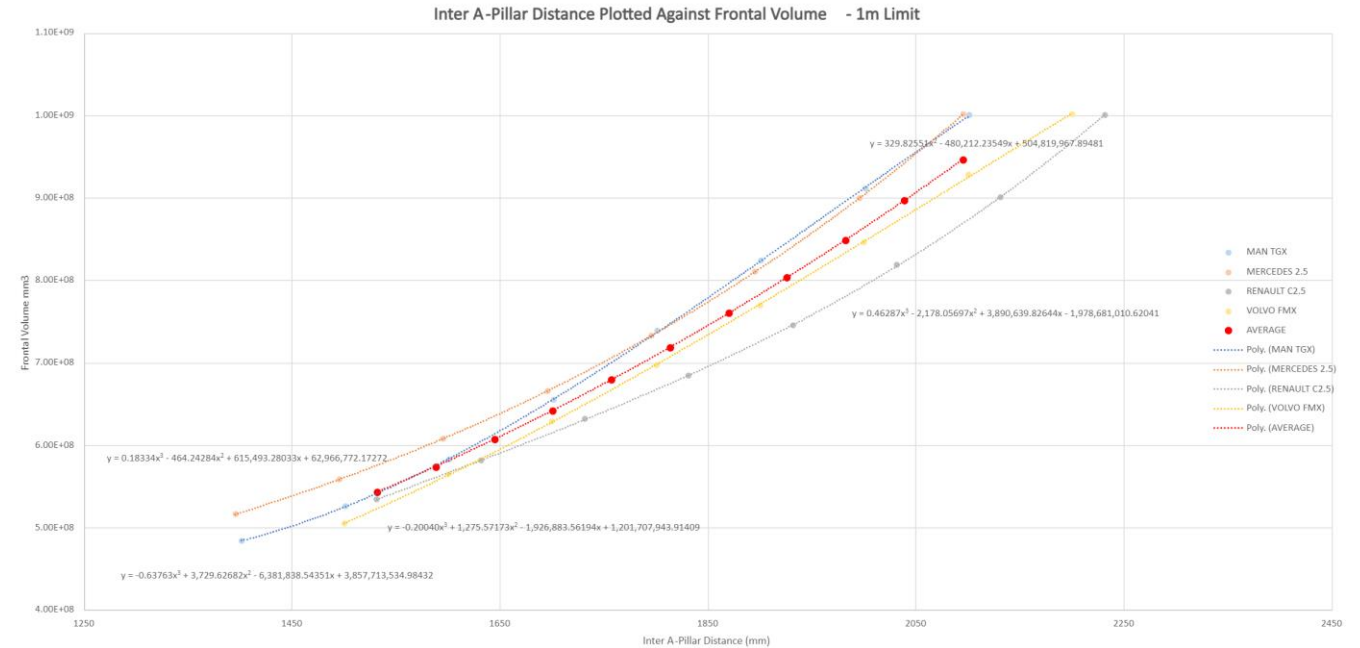

TESTING VOLUME REQUIRED FOR REDUCED INTER A-PILLAR DISTANCE.

- It was proposed at the last meeting that we could average the values for all vehicles at certain A-pillar distances to produce the requirement for volume
- To enable this we have captured the equations of the curves so that we can use these to find equivalent values at certain inter- A-pillar distance
- These data are then used to produce the Average curves shown in the graph where orange is for Level 1 Vehicles and Blue is for level 2 and 3 vehicles
- The equation of the red line for 1m^3 and 1.8m^3 could be used in the standard to derive volume requirements values for any inter A-pillar distance
- We then used the new equation of line to extrapolate the curves to cover a wide range of values as the graph on the right

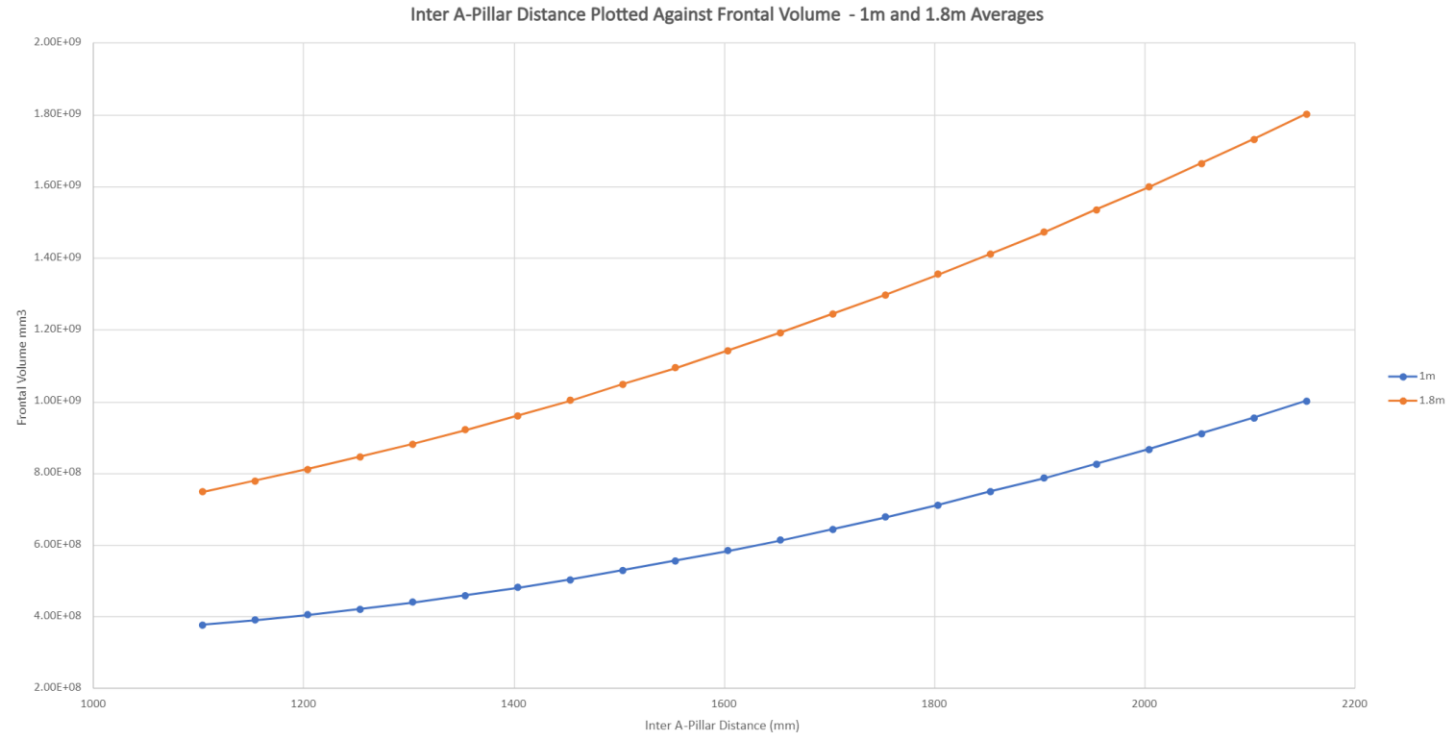

$$1.8\text{m}^3 Y=392.13379x^2 - 275,907.57455x + 573,475,207.82932$$

$$1.0\text{m}^3 Y=329.82551x^2 - 480,212.23549x + 504,819,967.89481$$

SUMMARY

- We are happy with the simpler method of measuring inter A-pillar distance
- The process followed for the definition of the volume required for reducing inter A-pillar width has gone well and without issues
- This led to the proposal that the following equations can be included in the standard to allow a manufacturer to find the exact volume requirement for the exact inter A-pillar distance

$$1.8\text{m}^3 Y=392.13379x^2 - 275,907.57455x + 573,475,207.82932$$

$$1.0\text{m}^3 Y=329.82551x^2 - 480,212.23549x + 504,819,967.89481$$

- This process did highlight a further issue as defined in the following presentation



30TH UNECE VRU PROXI GROUP: POTENTIAL AMENDMENT TO ENSURE FRONTAL DIRECT VISION REQUIREMENTS

DR STEVE SUMMERSKILL

CONTENTS

- A new issue which has been identified by the new work recently performed
- Reminder of the premise that established the method used for UNECE regulation 167
- Highlighting a concern that has arisen which means that designs can be produced which do not meet the ‘spirit’ of the regulation
- Ways forward

PROPORTIONAL FRONT VOLUME BY A-PILLAR WIDTH

- The content above explores the issue of new designs where A-pillar distance is reduced when compared to vehicle sample that was used to defined DVS system

Decreasing inter A-pillar distance

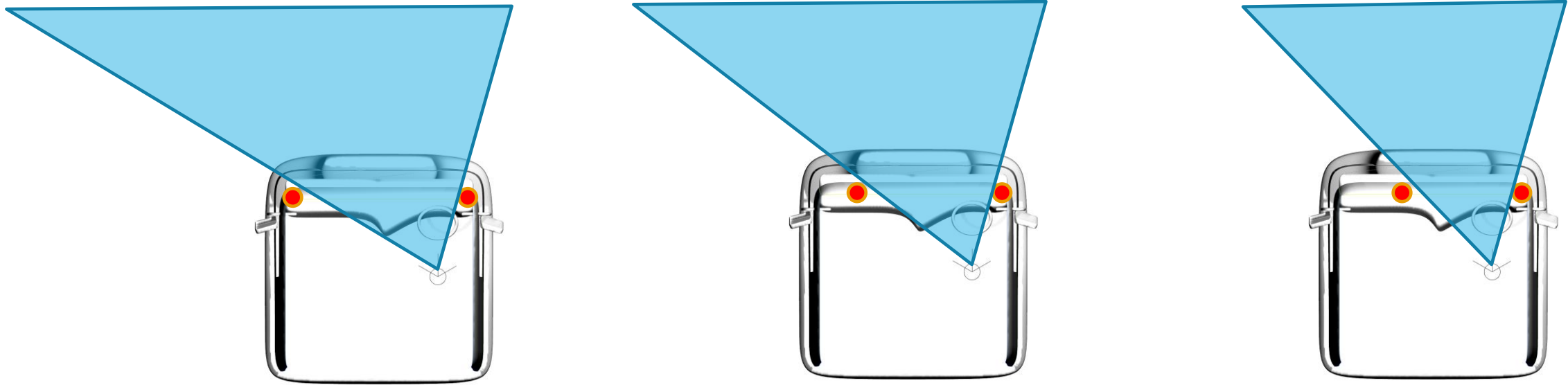

ADDRESSING THE CONCERNS

- However, if manufacturers choose to move the A-pillars rearwards towards the driver compared to the original sample they will be able to gain volume without improving the view of the area of greatest risk

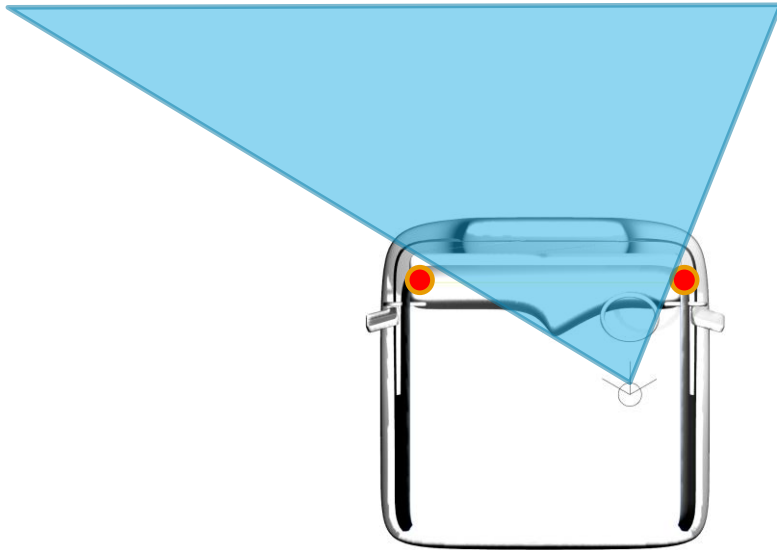

Original vehicle design

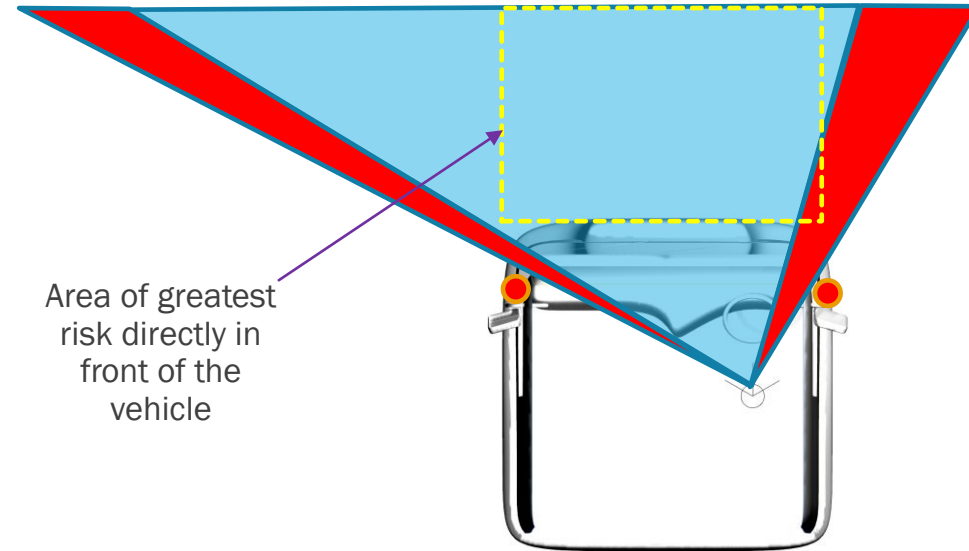

Redesign moves A-pillars rearwards

Red areas show volume gained outside of area of greatest risk for frontal collisions, **potentially allowing a vehicle to pass the minimum requirements without improving direct vision directly in front of the vehicle in the area of greatest risk.**

THE PREMISE THAT ESTABLISHED THE METHOD USED FOR UNECE REGULATION 167

- As discussed in numerous VRU Proxi Group meetings, the basic premise of Regulation 167 is that the volumetric approach is given real world context using VRU simulations and the distance from the side and front of the vehicle at which the head of the VRUs can be seen.
- For the front of the vehicle this involves the use of the three VRUs that placed directly in front of the vehicle to highlight the area of greatest risk established in the accident data analysis which supported the DVS design.
 - The driver should be able to see the VRU approaching the vehicle, and allow the VRU to be seen when they are walking directly in front of the cab where possible.
 - The Series 00 method defined average frontal average VRU distances of **1653mm** for Level 1 and **1958mm** for levels 2 and 3

Excellent

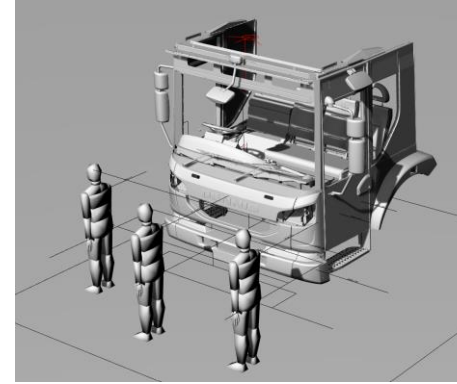

Good

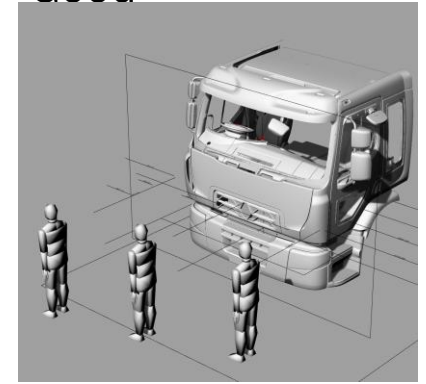

Pass

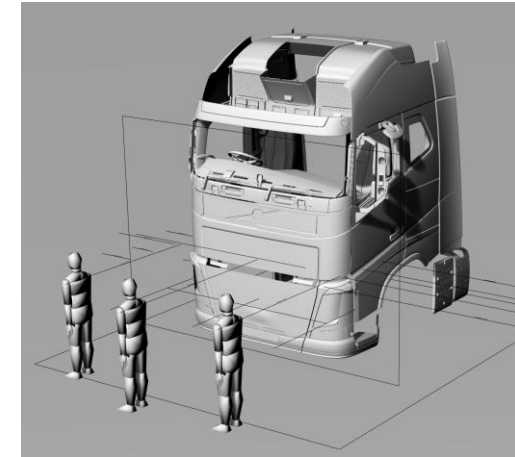

DEFINING THE SEPARATED APPROACH

- The LDS spent much time in the VRU Proxi meetings exploring how manufacturers could make design changes to meet the DVS minimum requirements
- It was established that manufacturers could meet the minimum requirements by improving older designs to the sides only, resulting in no improvement of direct vision to the front (32% of accidents occur to the front, mostly involving VRUs over the age of 65).
- **The separated approach** was defined to avoid this situation by requiring a volume in front of the vehicle.

Table 1
Minimum Values of Visible Volume

	<i>Minimum Volume (m³) of Direct Vision</i>		
	Level 1	Level 2	Level 3
Nearside Visible Volume	3.4	Not Specified	Not Specified
Front Visible Volume	1.8	1.0	1.0
Offside Visible Volume	2.8	Not Specified	Not Specified
Total Visible Volume	11.2	8.0	7.0

TECH NEUTRALITY

- It was noted by manufacturers that the DVS method was not tech neutral in that it is tied to A-pillar position
- The LDS team designed a new version of the standard with ACEA which used a subdivided assessment volume to define the requirements, but also repeatedly stated that new method should be equivalent to the Series 00 method shown in Regulation 167
- The LDS team highlighted again that the new method (known as option 3) could allow lateral improvements to once again replace the need to see the volume as per the description on the following slide

PROBLEMS WITH THE NEW VERSION TO ADDRESS TECH NEUTRALITY

- The new version (option 3 or option 4) once again allowed manufacturers to gain volume by making changes to the **side of the vehicle** and this means that the original method in the current standard and the amendment version are not equivalent
- This can be demonstrated in the example below, in both cases the 3 VRUs directly in front of the cab are in a blind spot between direct vision and indirect vision

167 series 00 - Front

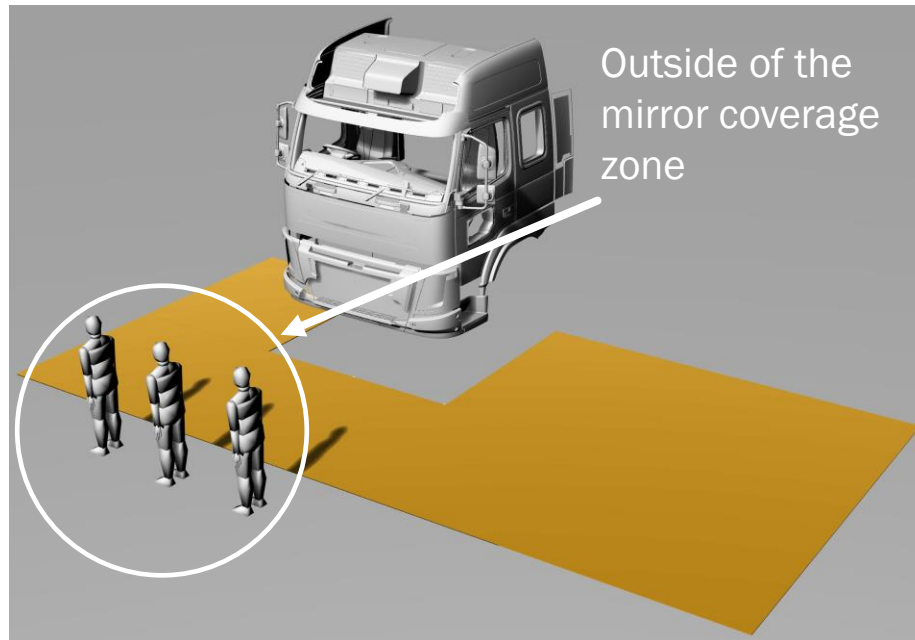

The vehicle **fails** the minimum requirement to the front and must be improved – e.g. lowered overall – lower windscreen and dashboard

Amendment version - Option 3 method - Front

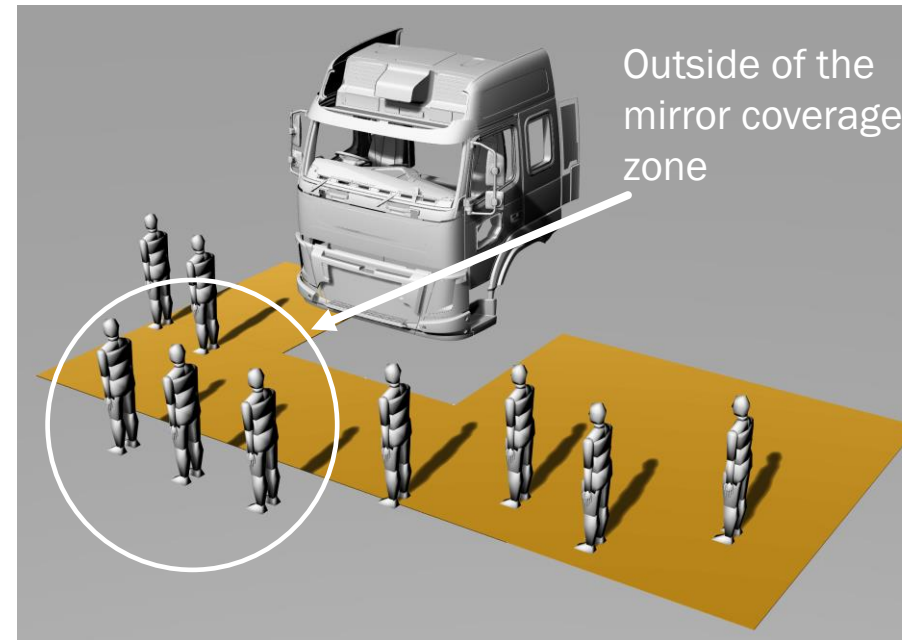

This vehicle fails the minimum requirement to the front and must be improved – manufacturers can gain volume by removing mirrors, lowering window edges and can then pass

NO improvement to frontal direct vision blind spots

TECH NEUTRALITY

- We therefore designed a new method to ensure that the intent of the standard (to allow the VRUs in front of the vehicle to be seen) as per the content in the next three slides.

HOW CAN WE ENSURE EQUIVALENCE BETWEEN THE TWO METHODS?

The premise is as follows;

- What volume is equivalent to the need to see three VRUs directly in front of the vehicle?
- We needed a way to define a frontal volume
- We have taken **the lateral extents** of the vehicle to define the volume directly in front of the vehicle as this is the area that contains the three VRUs for the Series 00 method. **Frontal Extents Volume (FEV)**.
- Therefore plotting the VRU distance against the Volume gives a trend line that can be used to calculate the volume that should be seen at a certain VRU distance in the same way as the method used to define the volume requirement for the series 00 version

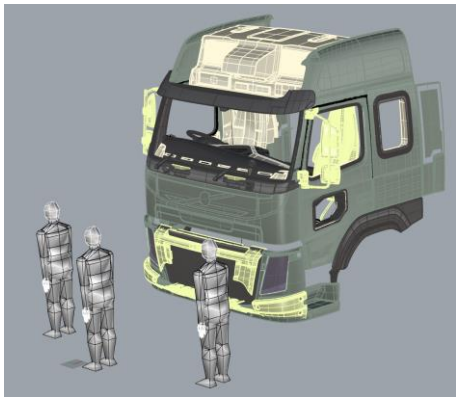

Three VRUs in front of the cab as defined in Series 00



Plan view of the area within which the VRUs are contained, therefore VRU distance should correlate well with volume as per the previous uses of this method

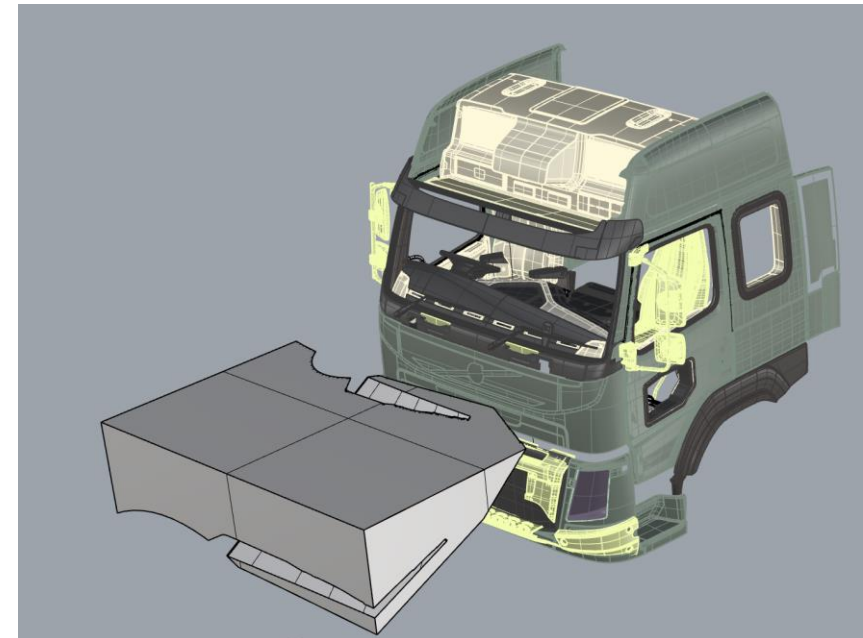

Volume that is visible between the lateral extents of the vehicle

HOW CAN WE ENSURE EQUIVALENCE BETWEEN THE TWO METHODS?

- So far we have performed this process for 15 vehicles across the sample of 50+
 - Therefore the suggested figures for the volume requirement are PROVISIONAL
 - As an indicative value for review by manufactures based upon the VRU distances agreed in the Series 00 version table
 - Level 1 vehicles (urban) would need to be able to see **0.441m³** in the FEV area (average VRU distance 1653mm)
 - Level 2 (construction) and 3 (long haul) vehicles would need to be able to see **0.114m³** in the FEV area (average VRU distance 1958mm)

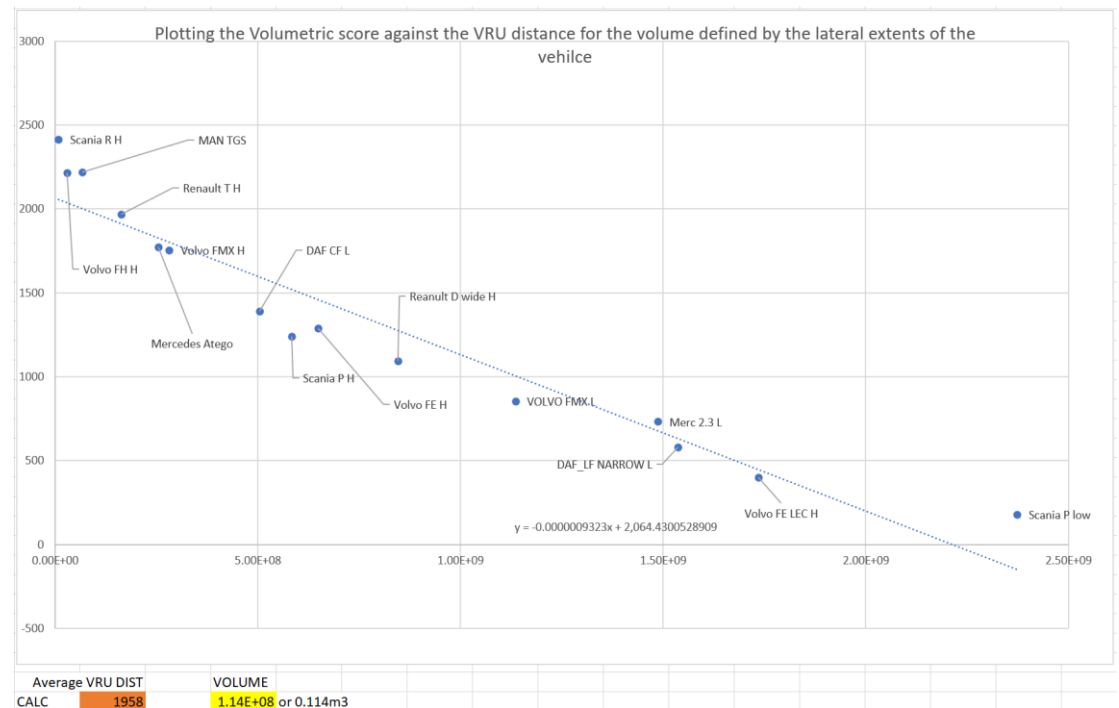
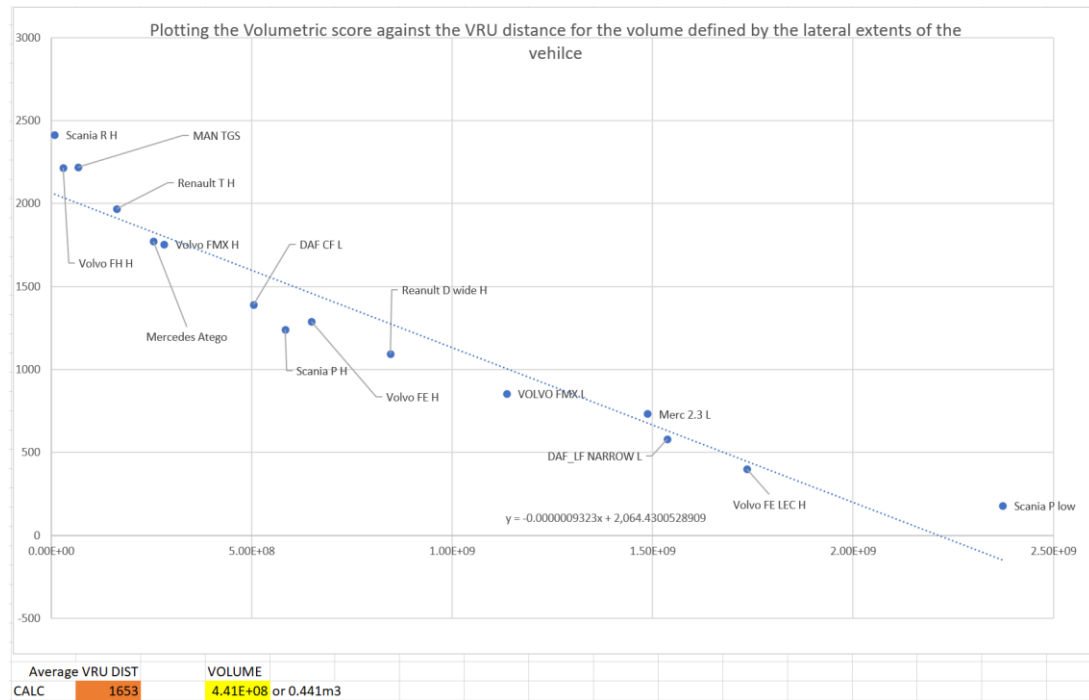

ADDRESSING THE CONCERNS

- By requiring a design to allow visibility of the FEV area we can avoid the issue shown below.

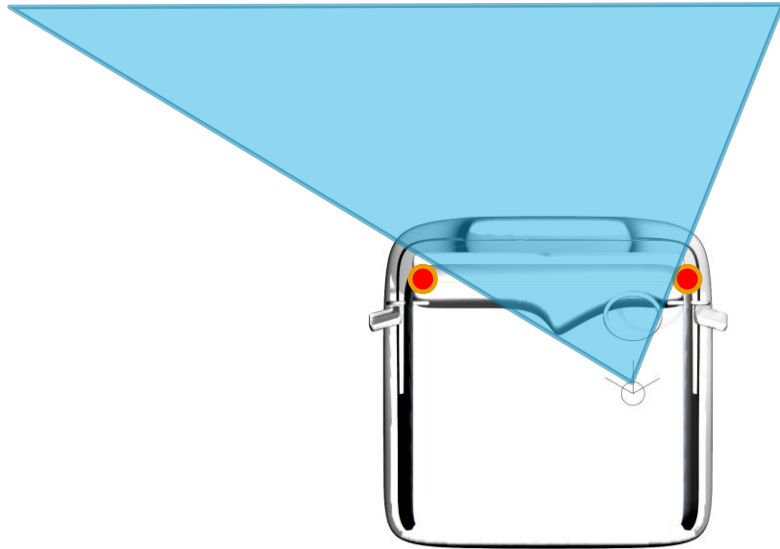

Original vehicle design

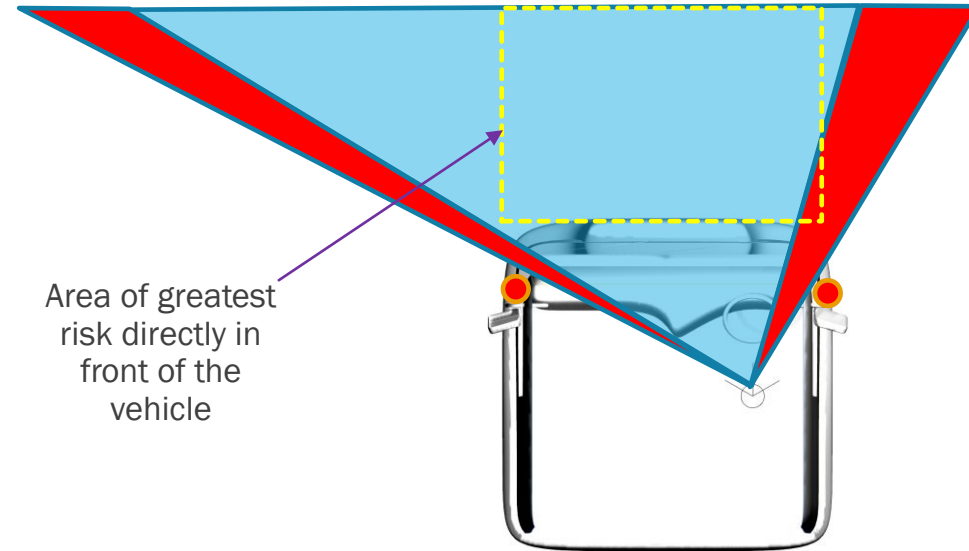

Redesign moves A-pillars rearwards

Red areas show volume gained outside of area of greatest risk for frontal collisions, potentially allowing a vehicle to pass the minimum requirements without improving direct vision directly in front of the vehicle.

SUMMARY

- We have been told in the Task Force that this issue is beyond the current Terms of Reference and so we are presenting this issue to you to get feedback on whether this is worth pursuing
- We think that we need a solution to this issue and it would be possible with the content presented today to get an amendment into the standard quickly.
- To be clear we propose that the existing frontal requirements be augmented with the requirement for a level 1 vehicle to see **0.441m³** of the FEV area
- Level 2 vehicles should be able to see **0.114m³** of the FEV area
- We are not making the requirement any more onerous, we are simply ensuring that the design intent of the standard is met
- We are happy to discuss

Project information

Thank you for your attention, are there any questions?

Dr Steve Summerskill (s.j.summerskill2@lboro.ac.uk)

Dr Russell Marshall

Dr Abby Paterson

Anthony Eland

Design Ergonomics Group

Loughborough Design School

Loughborough University

United Kingdom