

Dynamic assessment of the injury protection of seats:
Physical and virtual dummy models for low severity tests

Prof Astrid Linder PhD, MSc

Swedish road and transport research institut

vti

EqOP workshop #1

6 September 2023, BASt Bergisch Gladbach

Astrid Linder

Professor, Traffic Safety, VTI
Adj Prof, Injury Prevention, Chalmers
PhD, Mechanical Engineering
MSc, Engineering Physics

Research Areas

Crash Safety and Injury Prevention

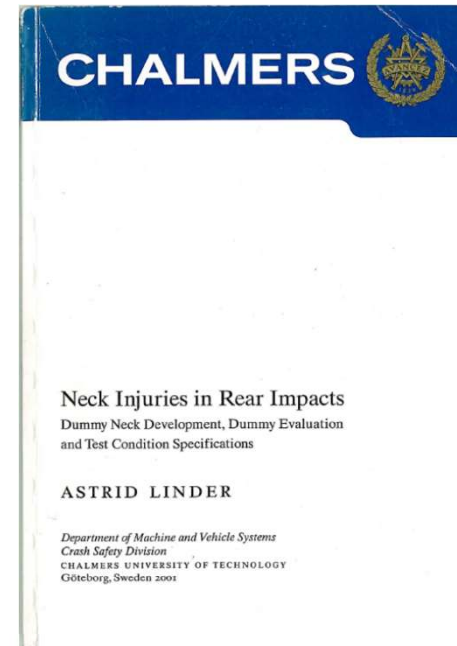
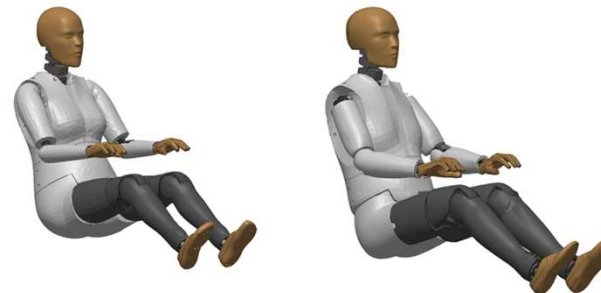
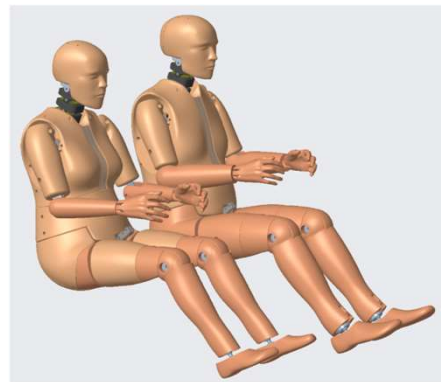
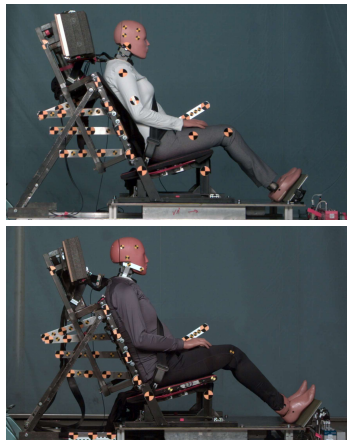

BioRID: Biofidelic Rear Impact Dummy

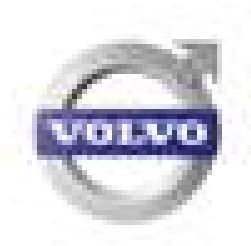

Whiplash – Injury risk

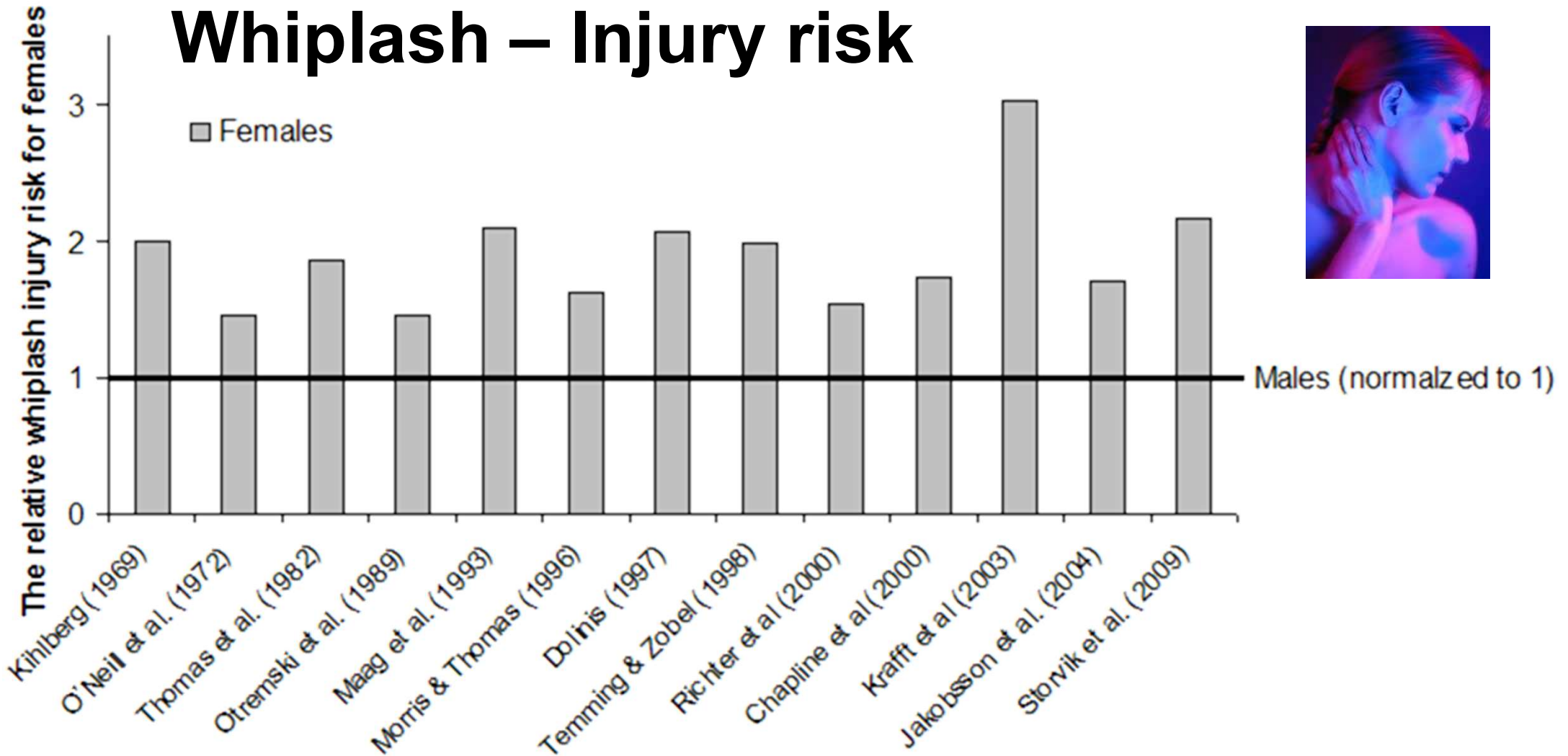

Source: Carlsson 2012

BioRID

Height 1.77 m

Weight: 78 kg

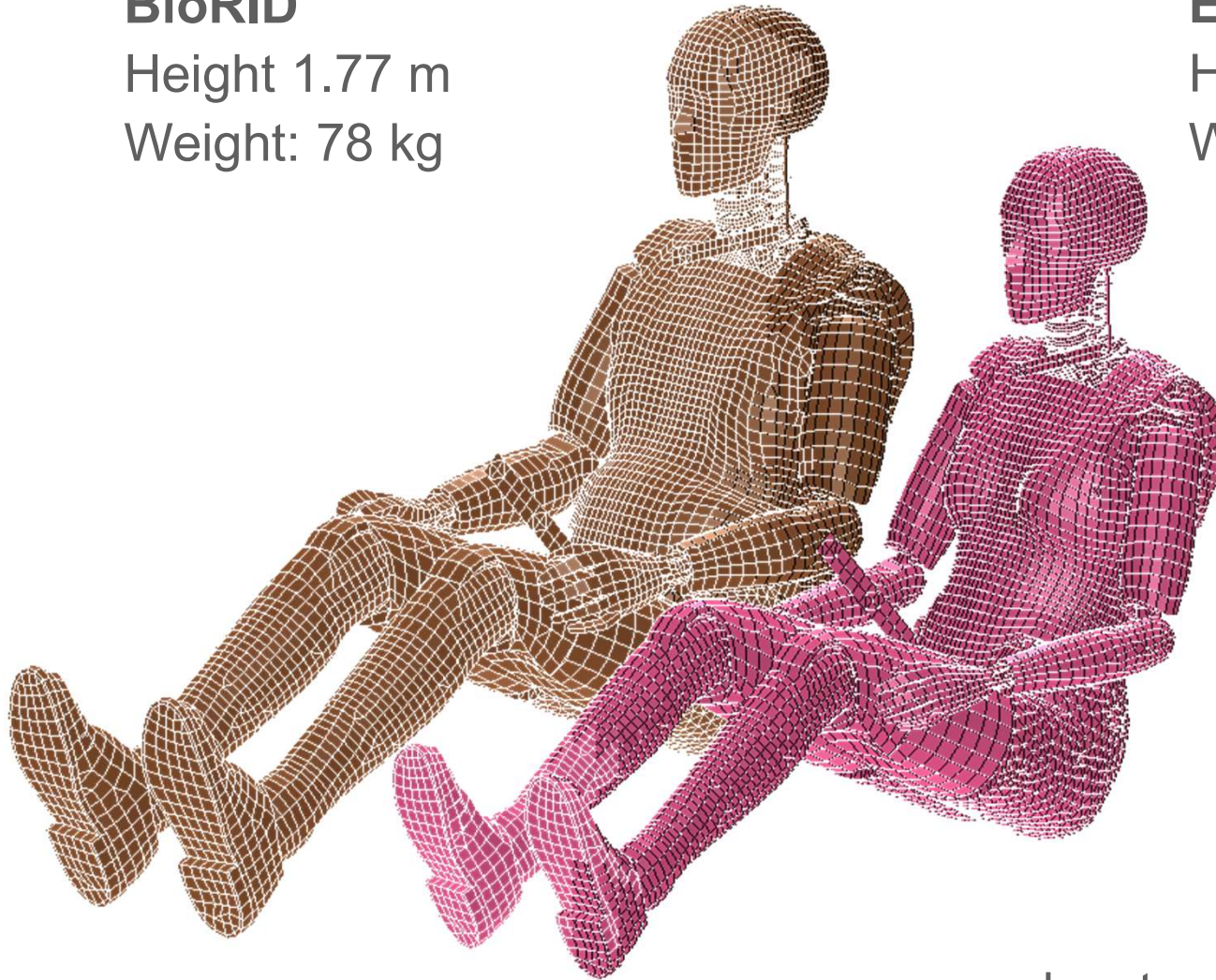

EvaRID

Height: 1.62 m

Weight: 62 kg



www.adseat.eu

vti

Seat performance, risk of PMI (whiplash)

Kullgren et al. (IRCOBI 2013)

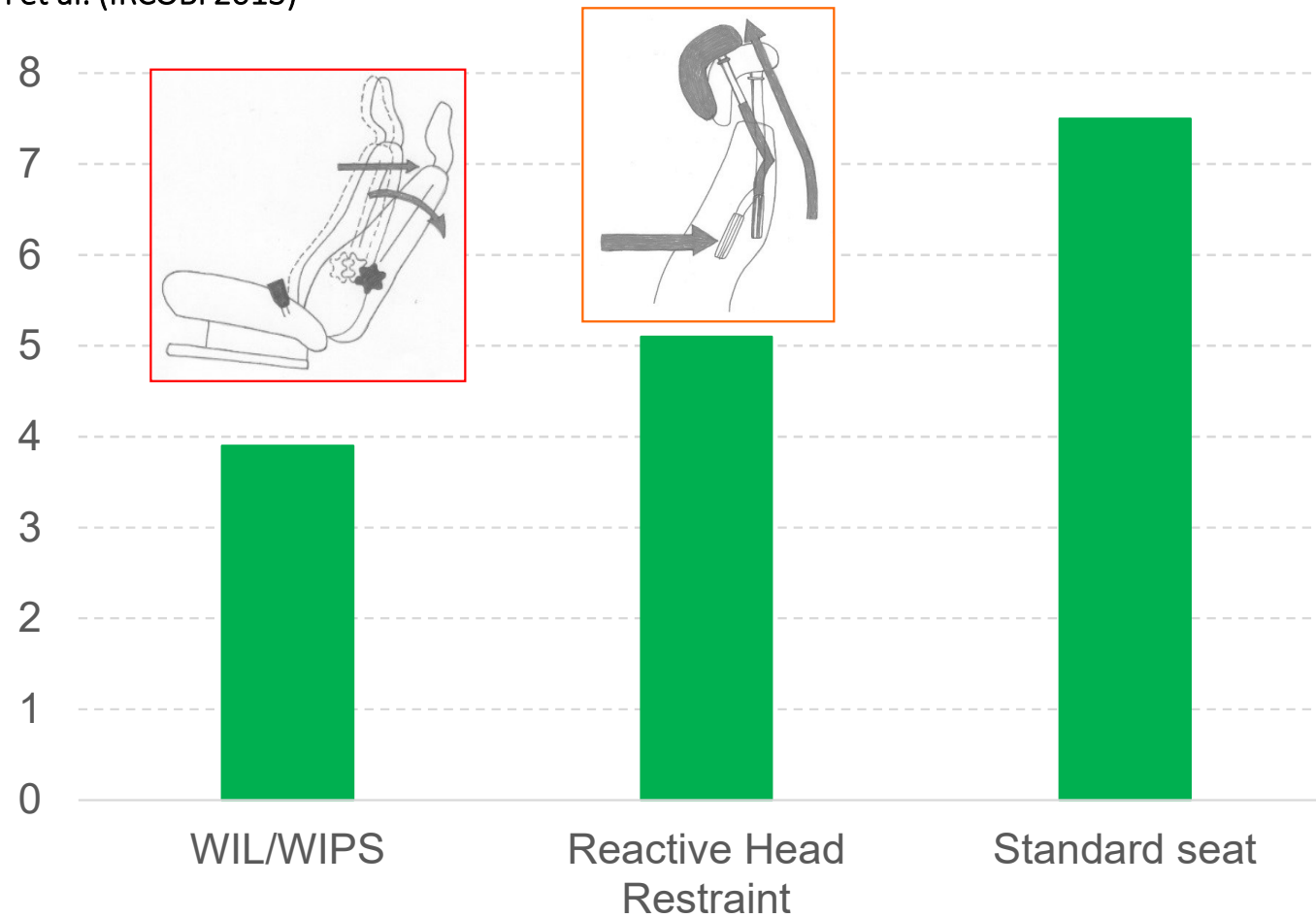

Seat performance, risk of PMI (whiplash)

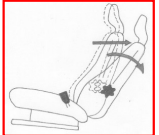
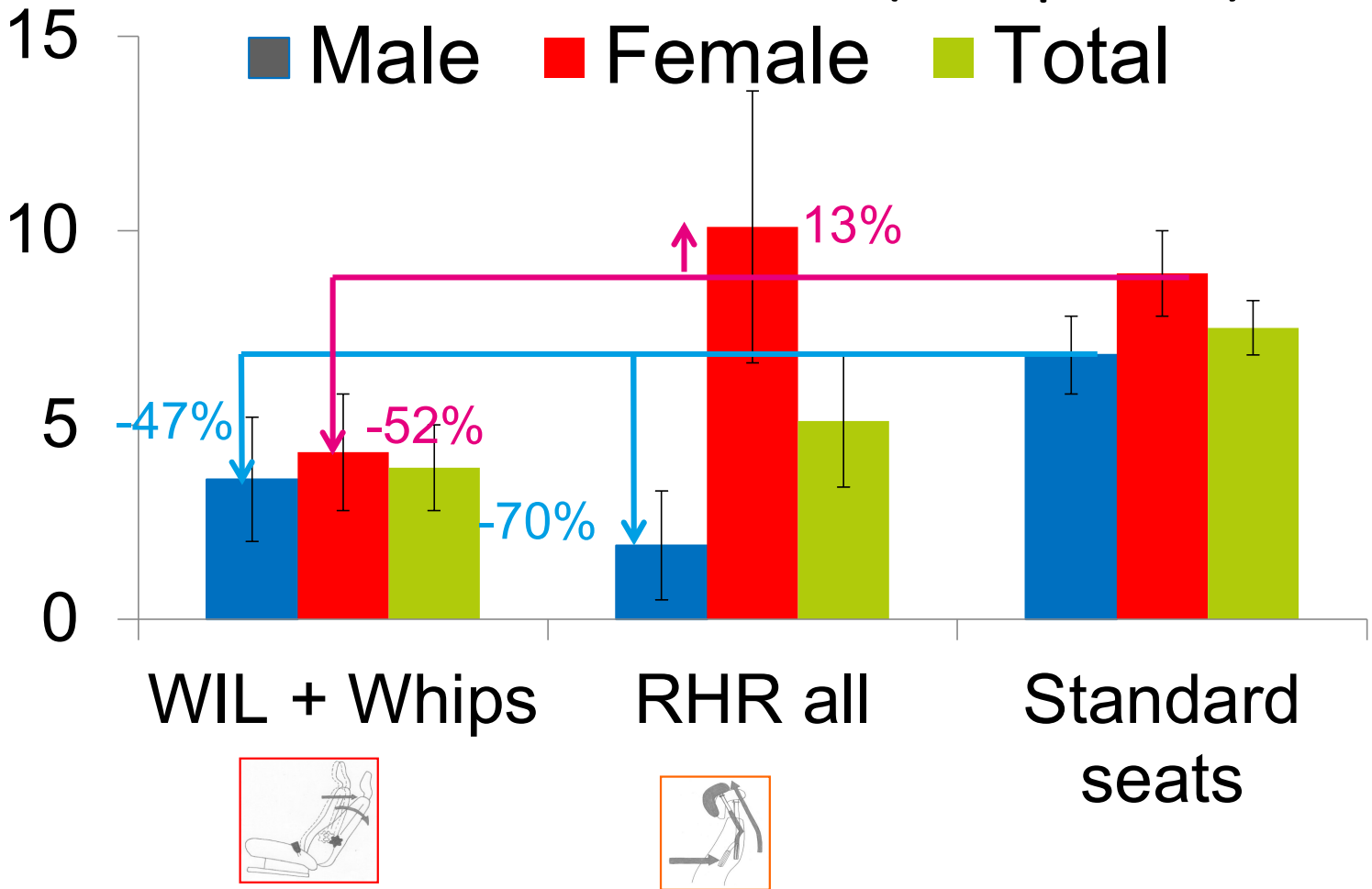

Kullgren et al. (2013) Development of Whiplash Associated Disorders for Male and Female Car Occupants in Cars Launched Since the 80s in Different Impact Directions, IRCOBI Conference.

Development, relative injury risk

Folksam

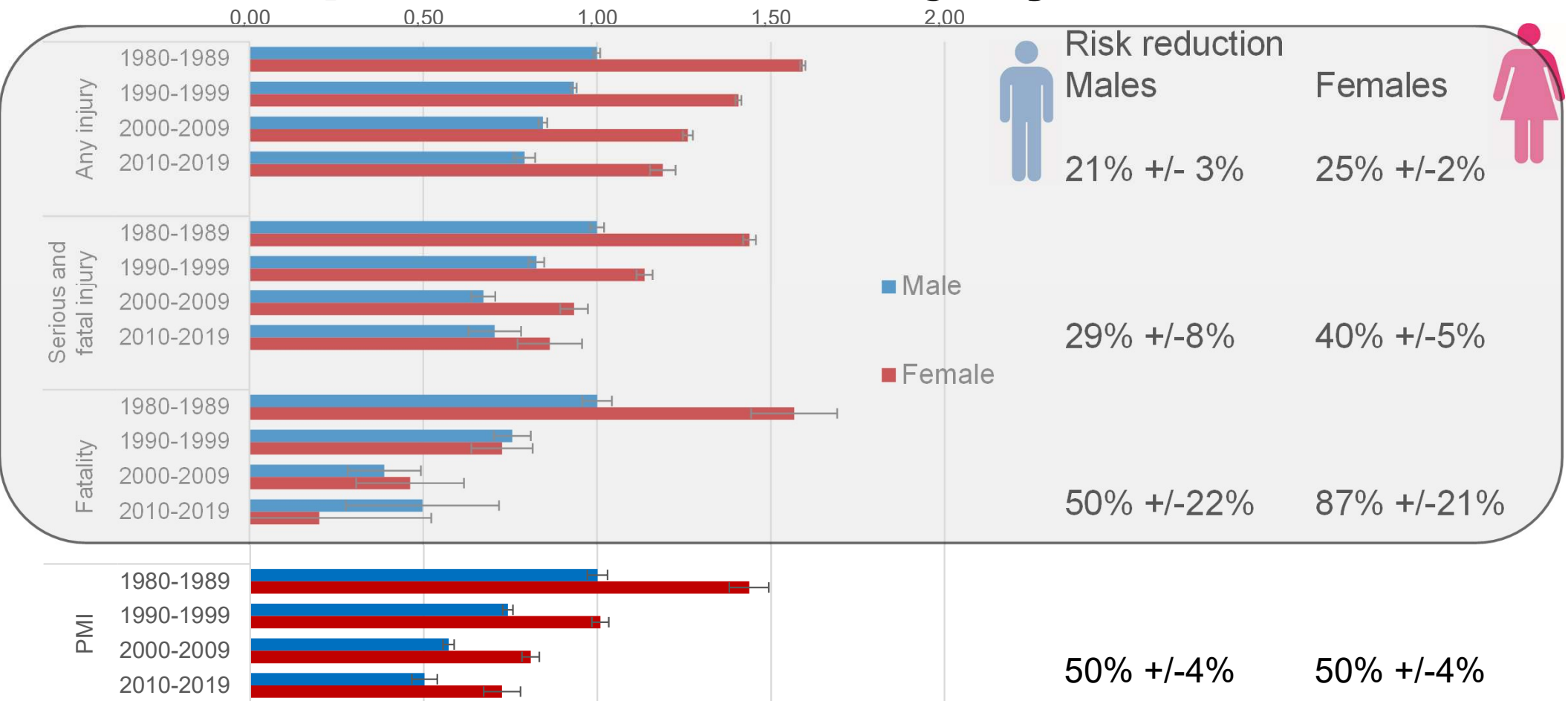

Kullgren et al. (2020) Developments in car crash safety since the 1980s, IRCOBI Conference, IRC-20-14



VIVA+ 50F and 50M

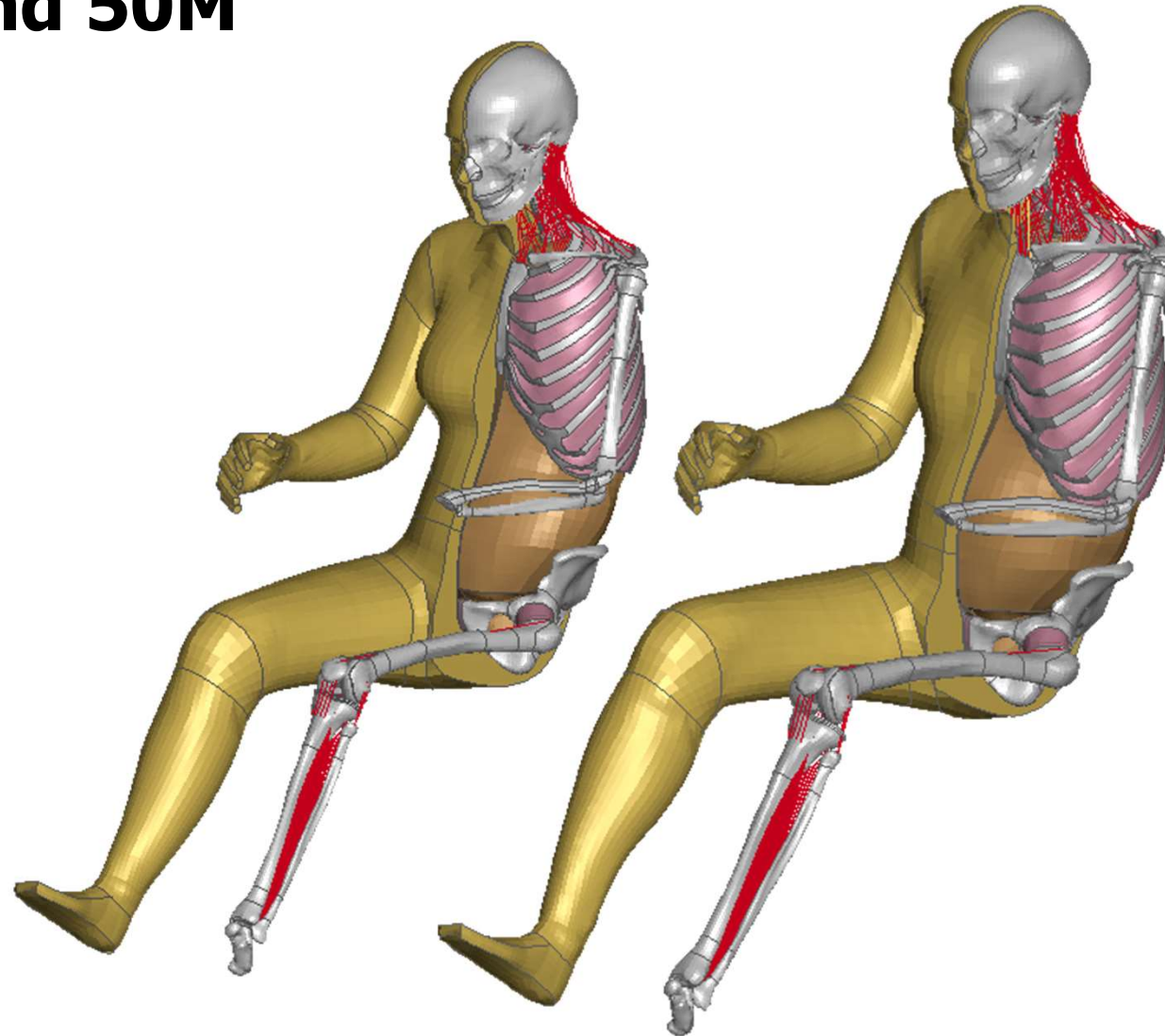
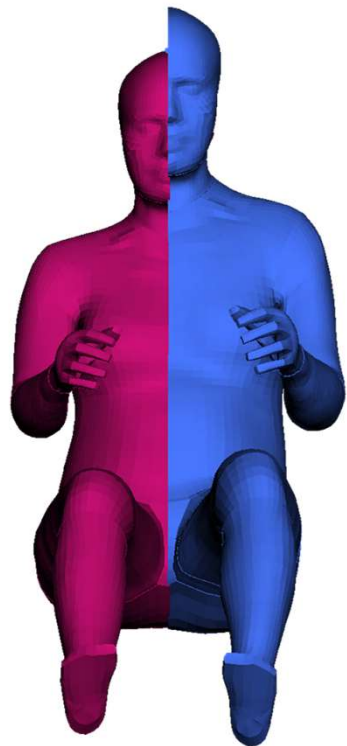

Seat Evaluation Tool, SET 50F and 50M

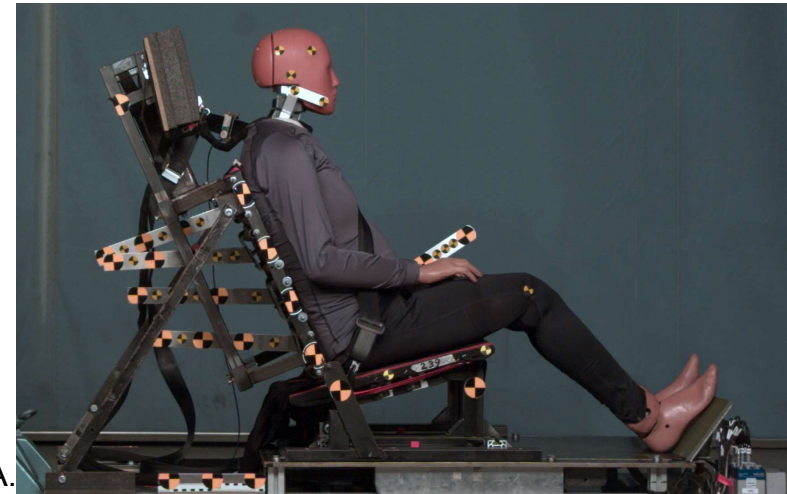
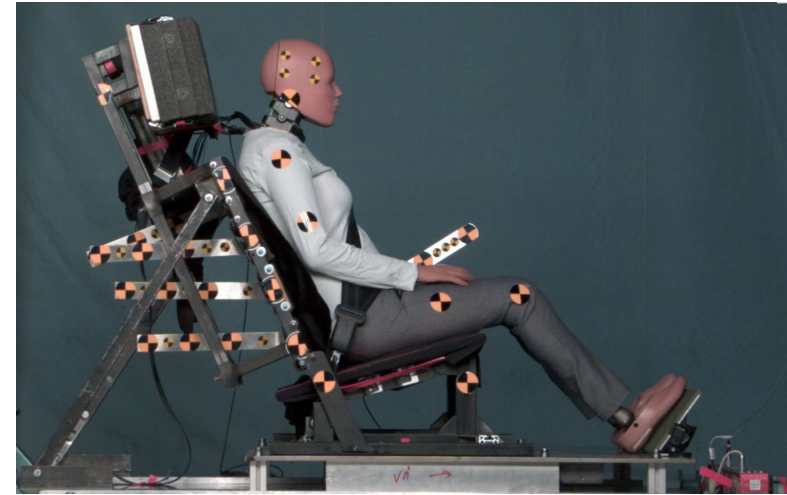
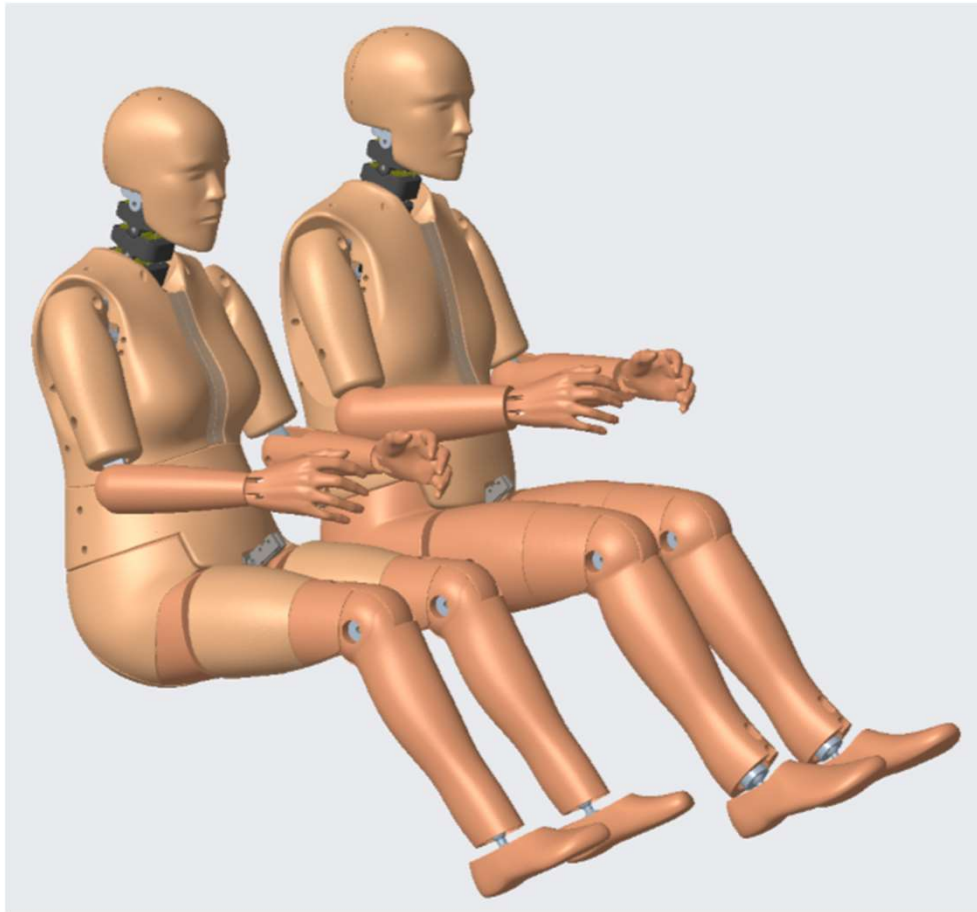

Karemyr et al. (2022) The Seat Evaluation Tools (SETs), VTI report 1147A.



Average female and male

Weight and height
Shape of the torso
Stiffness of the neck

Geometry: humanshape.org

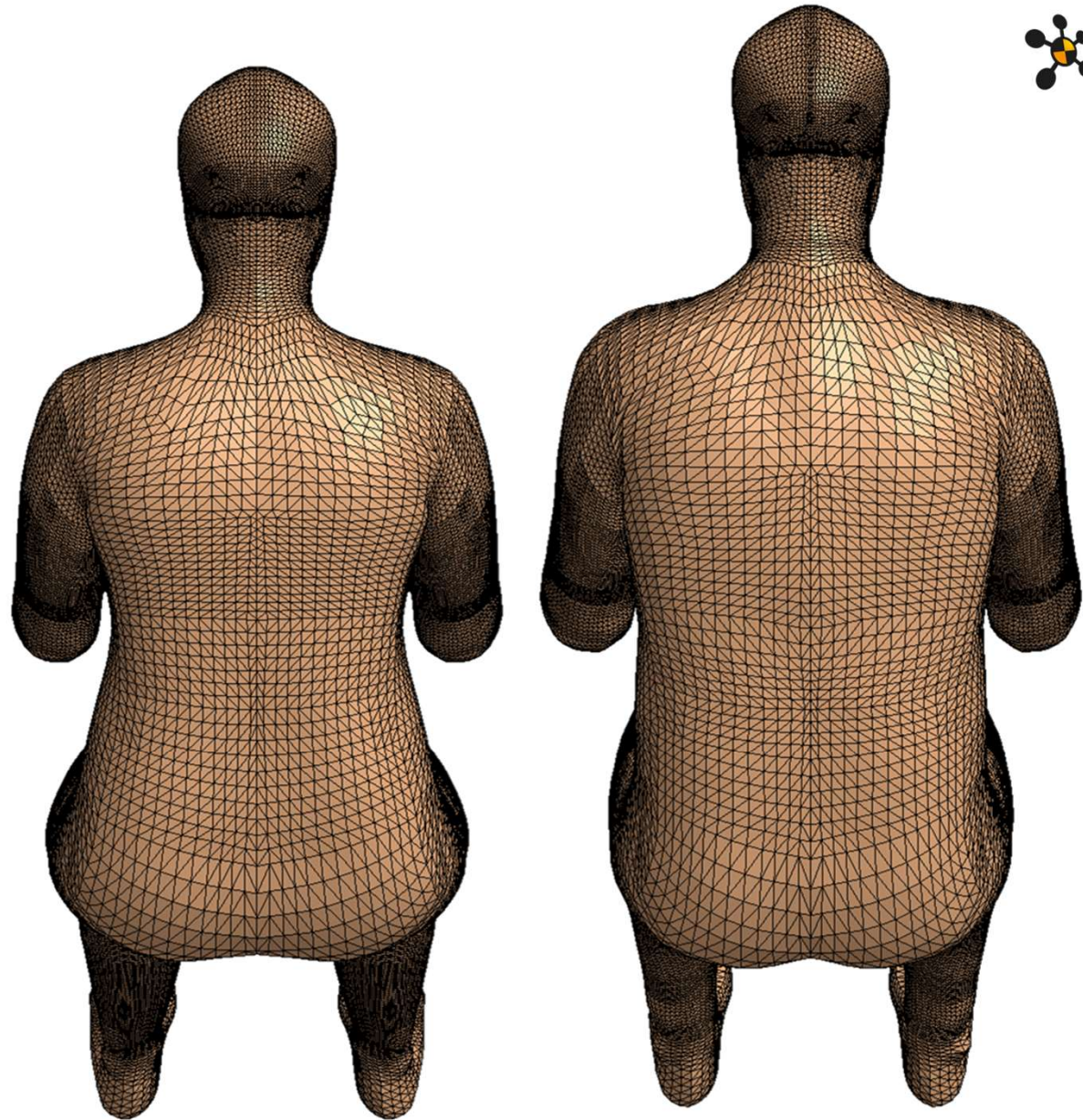

Spine

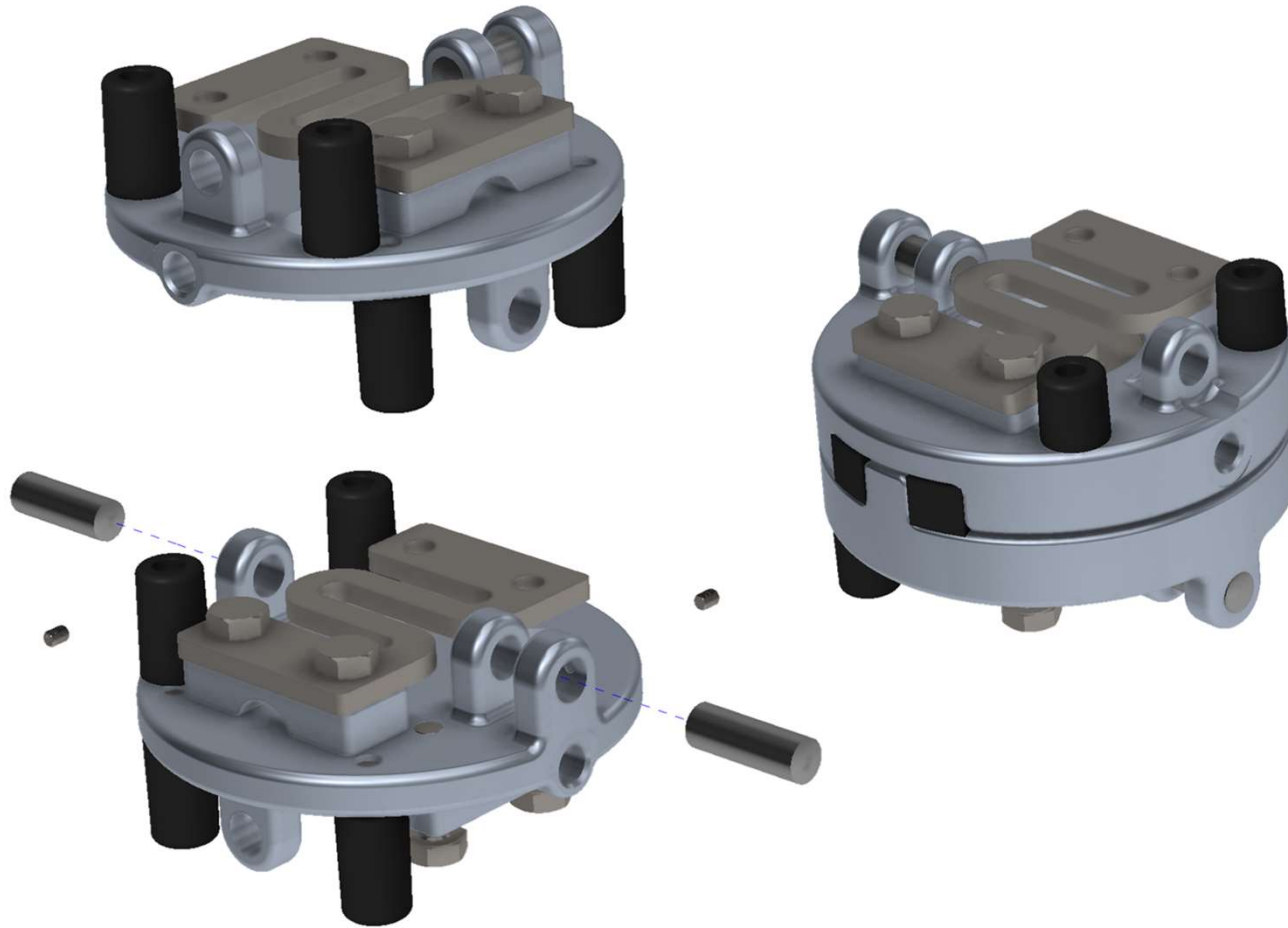

The cervical spine

Damping system (BioRID style)
placed inside head

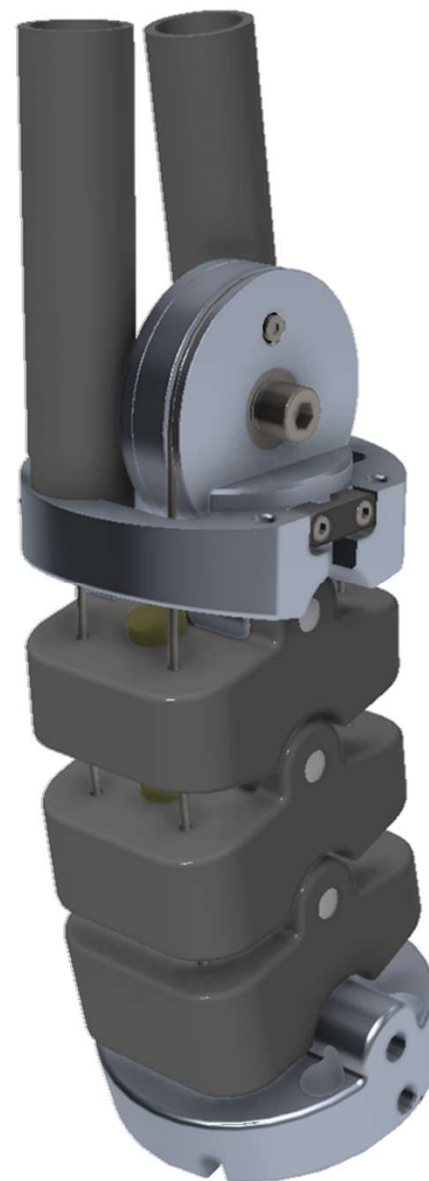

Chest and shoulder

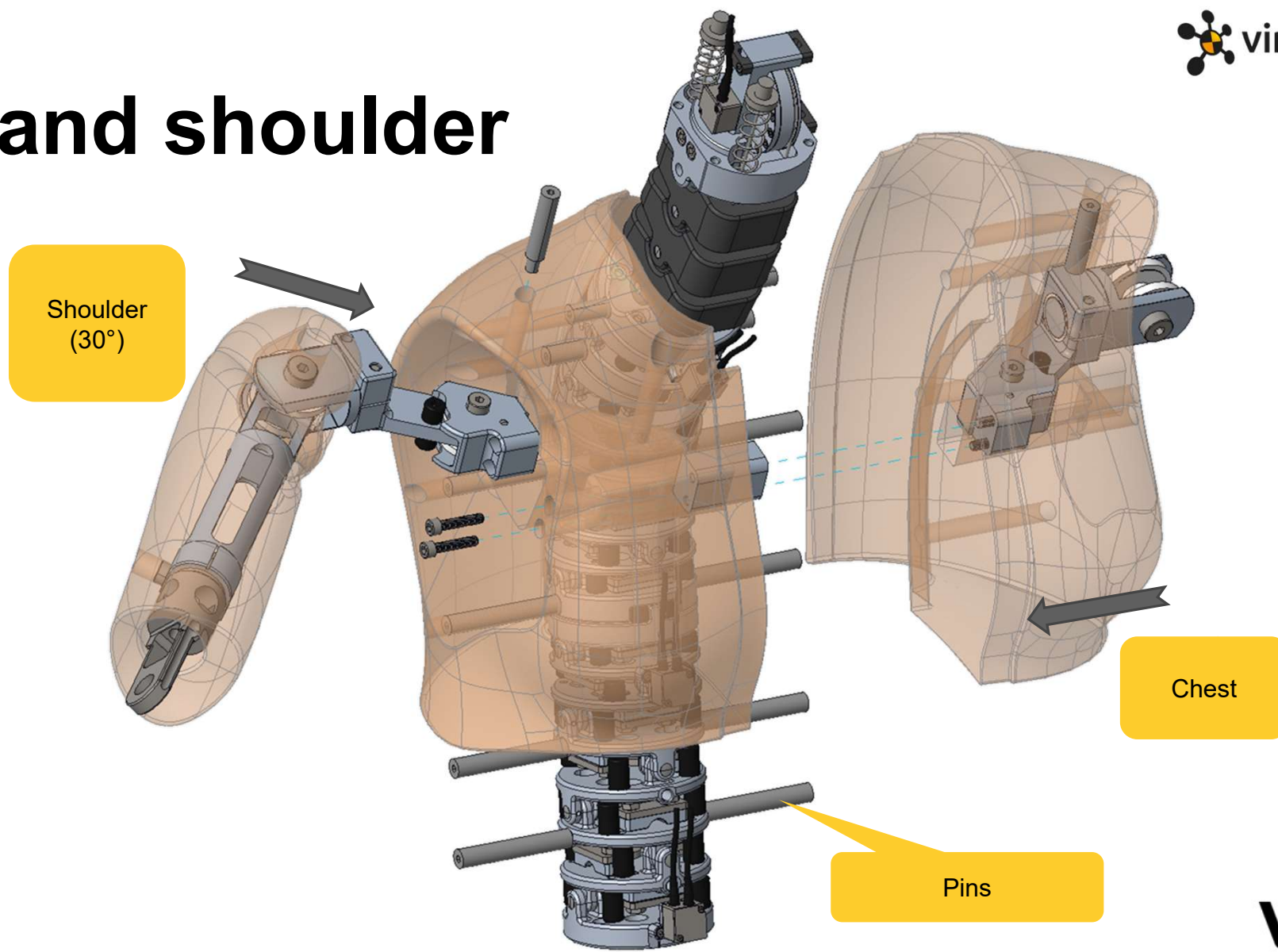

Design and measurement equipment

Combined gyro & 3-axis accelerometers at C1, T1, T8 & Pelvis

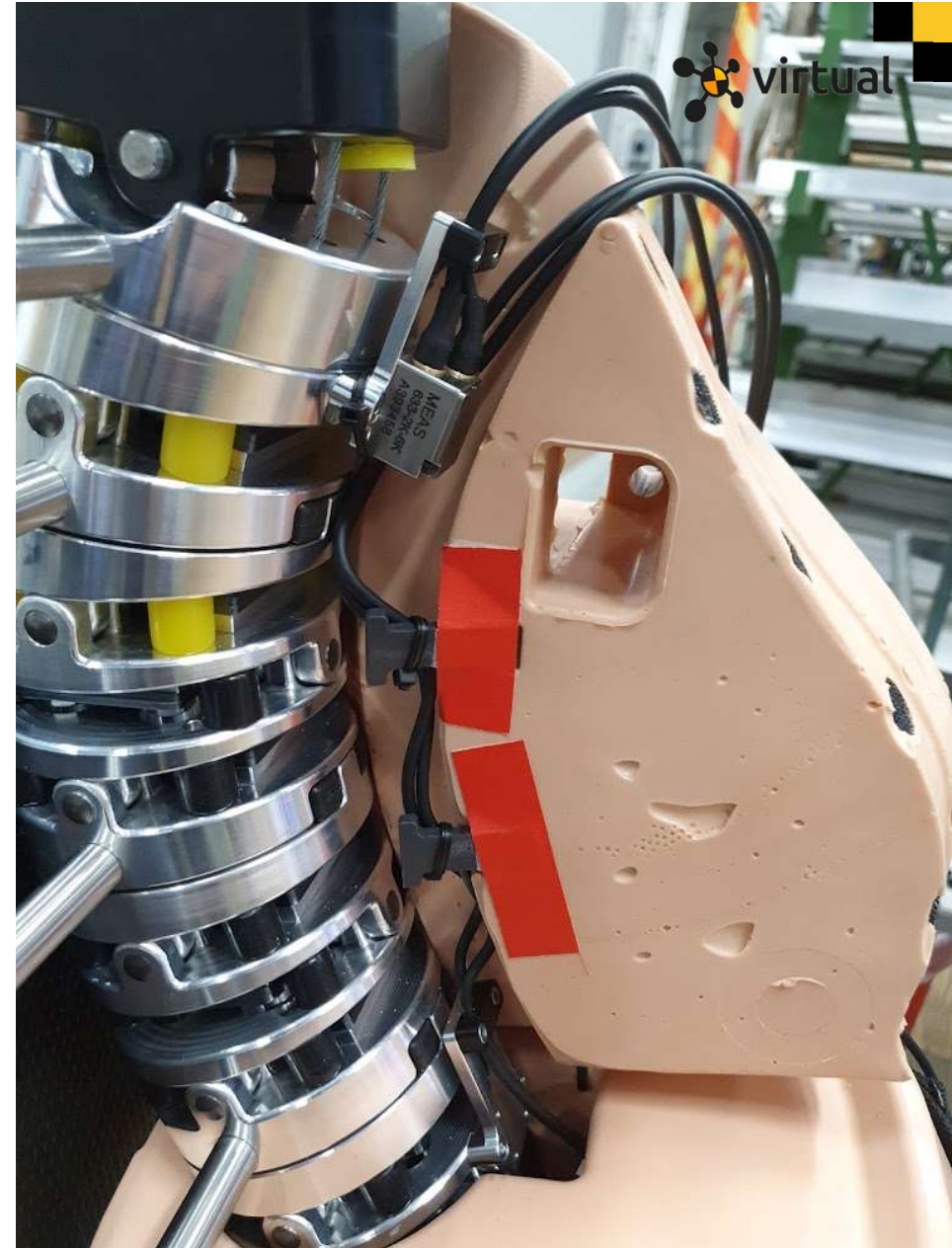
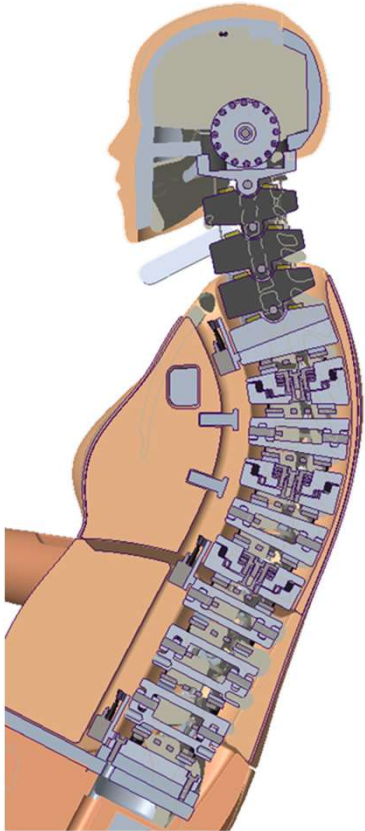



SETs and FE SETs

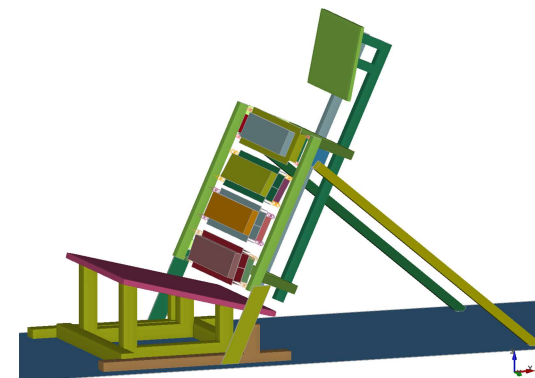
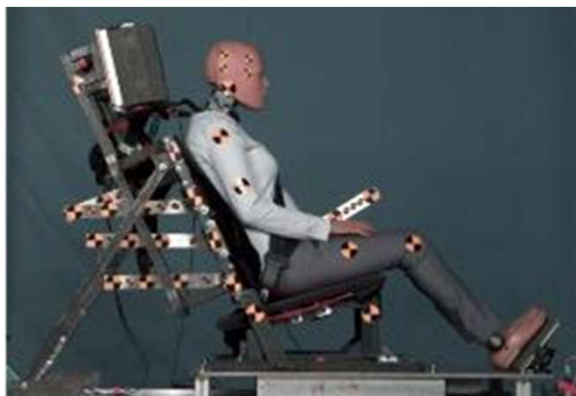

Next steps

- Fine tuning of the SETs: Rubber block between vertebrae and adjusting weights.
- Test at Autoliv with 2 different seats, Euro NCAP 16 km/h mid severity pulse.
- SETs displayed at Carhs, the SafeSeats Experience, 15-16 November.
- Publication of SETs v0.2 and open-source FE SETs

Thank you for your attention

Contact:
Astrid.linder@vti.se

