

SLR-AVM-02

IF, FOR DESIGN AND SAFETY REASONS, WE'D LIKE INTRODUCE ADDITIONAL REAR POSITION LAMPS ON THE TOP OF THE CAB (POSSIBLY A UNIQUE «RED LINE») HOW COULD IT BE DONE (FOR VEHICLES > 2550 MM) IF REAR POSITION LAMP NUMBER IS LIMITED TO 4?

«ADDITIONAL» REAR POSITION/DIRECTION INDICATOR /REAR REFLECTOR DEVICES (< 400 mm respect to outer edges) For tractors width > 2550 mm

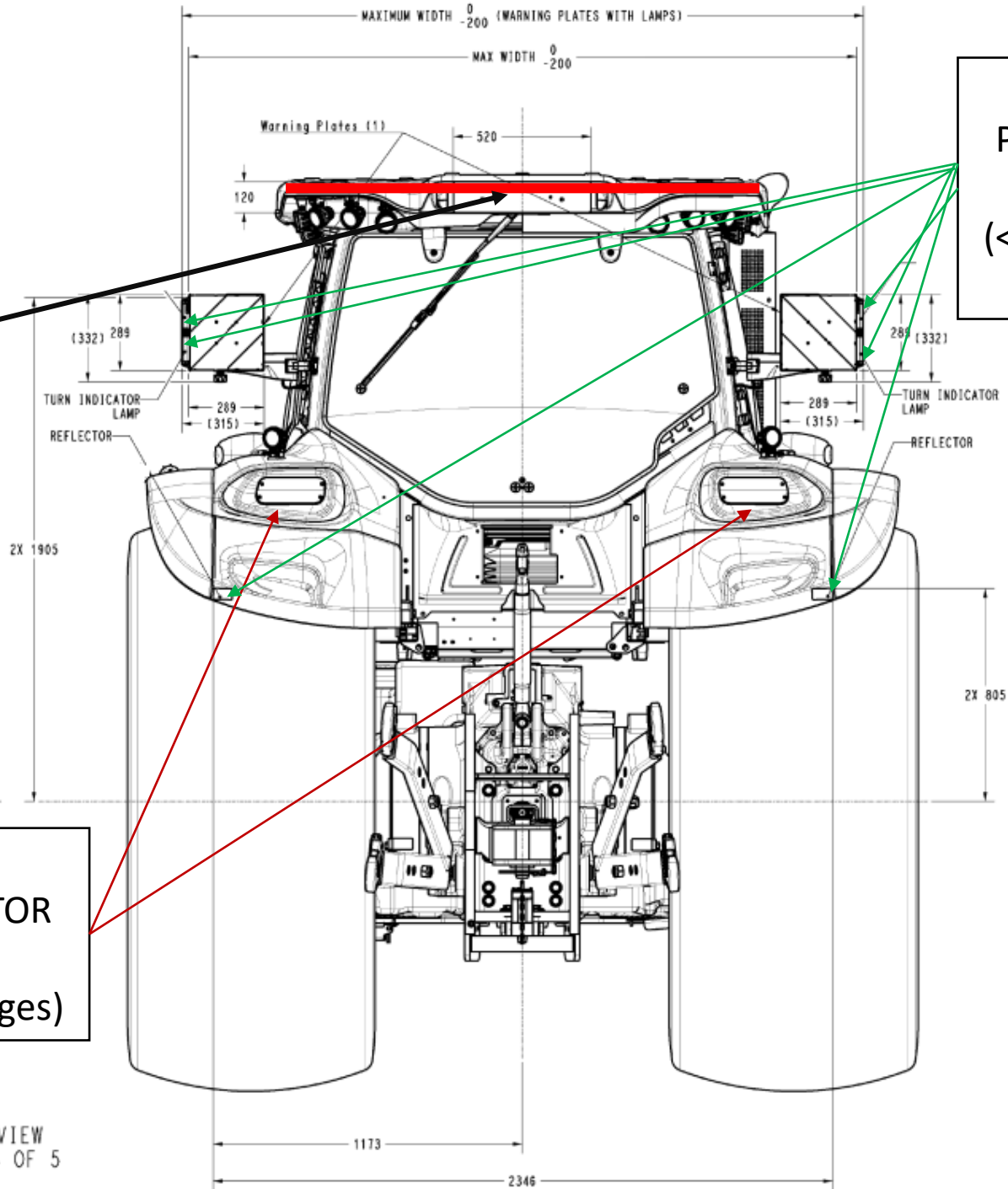

«ORIGINAL» REAR POSITION/DIRECTION INDICATOR /REAR REFLECTOR DEVICES (> 400 mm respect to outer edges)

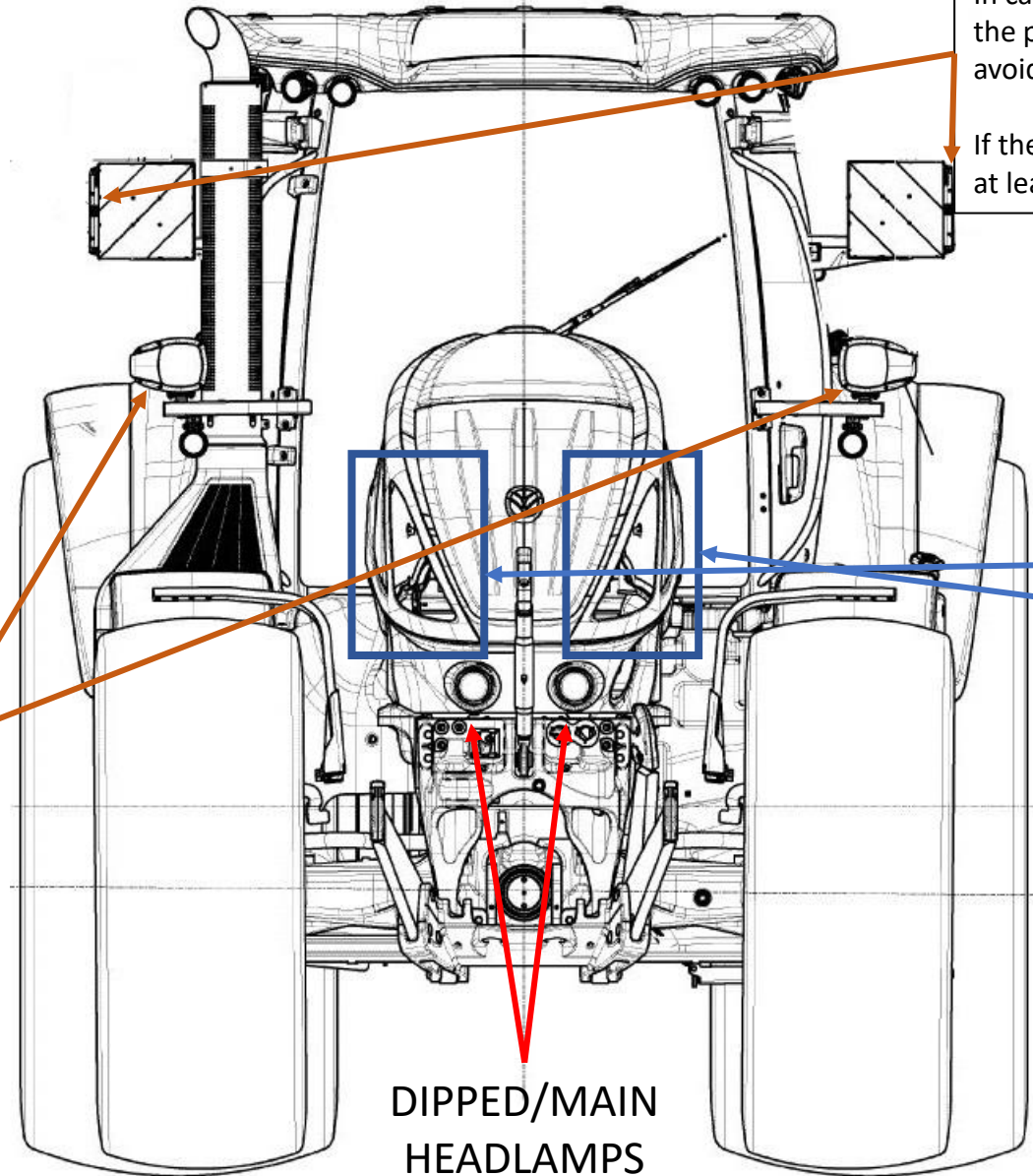

«ADDITIONAL» FRONT POSITION LAMPS or
END OUTLINE MARKER LAMPS??
In case the tractor is much wider than this configuration,
the presence of «end outline marker lamps» could
avoid to respect the max 400 mm for «original» front position lamps?
If the only way is front position,
at least 6 front position lamp could be needed

«PREFERRED» POSITION
FOR DRL INSTALLATION
(> 400 mm from outer edge)
ALSO IF APPROVED AS FRONT POSITION LAMP
(to keep them ON when dipped beam headlamps are
ON, for design reasons),
NOT POSSIBLE TO INSTALL THEM WITH CURRENT
WORDING (distance between internal edges)

«ORIGINAL» FRONT POSITION LAMPS
(< 400 MM from outer edge
for tractors up to 3000 mm)

DIPPED/MAIN
HEADLAMPS