



---

# GRSP UNECE Regulation No. 14 Workshop

---

GRSP UNECE Regulation No. 14 Expert Workshop  
on Extended Use Positions  
16.05.2024 | Matthias Schießler | BAST

# Approach

- ▶ Different dummies as well as volunteers from the workshop were placed in six different seating configurations in the same vehicle seat:
  - ▶ For each seating configuration the H-Point was determined with the H-Point Manikin
  - ▶ H-Points targets were defined in accordance with R94, R137 (Hybrid III) and Euro NCAP MPDB (THOR) test protocols
  - ▶ Finally, pictures taken by a fixed camera were overlaid with the permitted areas defined in R14 or described in OICA's proposal

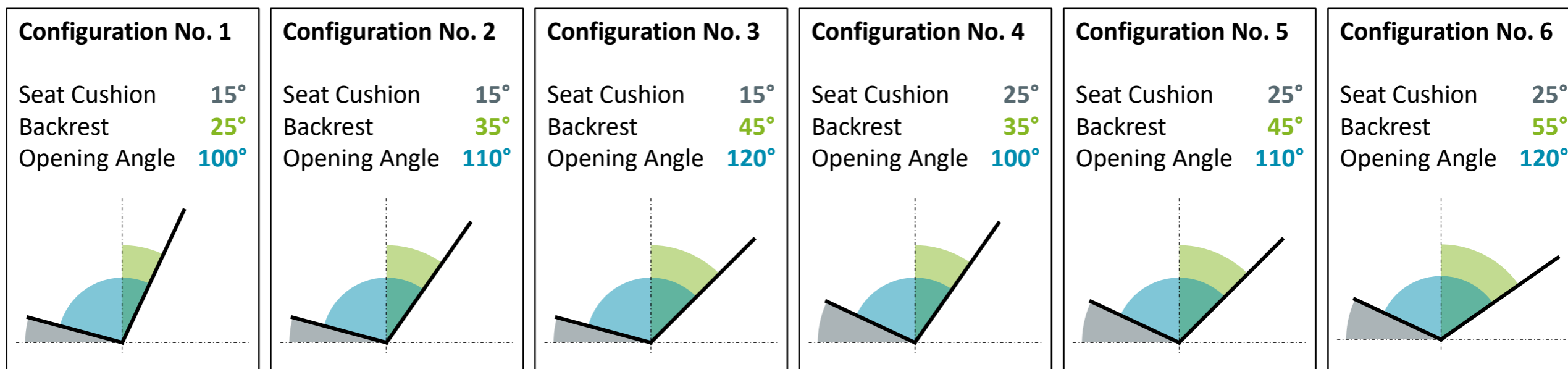

# OICA's Proposal for R14 Extension

- ▶ The permitted areas for the effective upper and lower belt anchorage points are redefined for extended use positions:
  - ▶ Permitted area for the effective upper belt anchorage point is redefined and rotates accordingly to the seat back
  - ▶ Permitted areas for the lower belt anchorage points rotate with the inclination change of the seat cushion or by  $\frac{1}{3}$  of the inclination change of the seat back

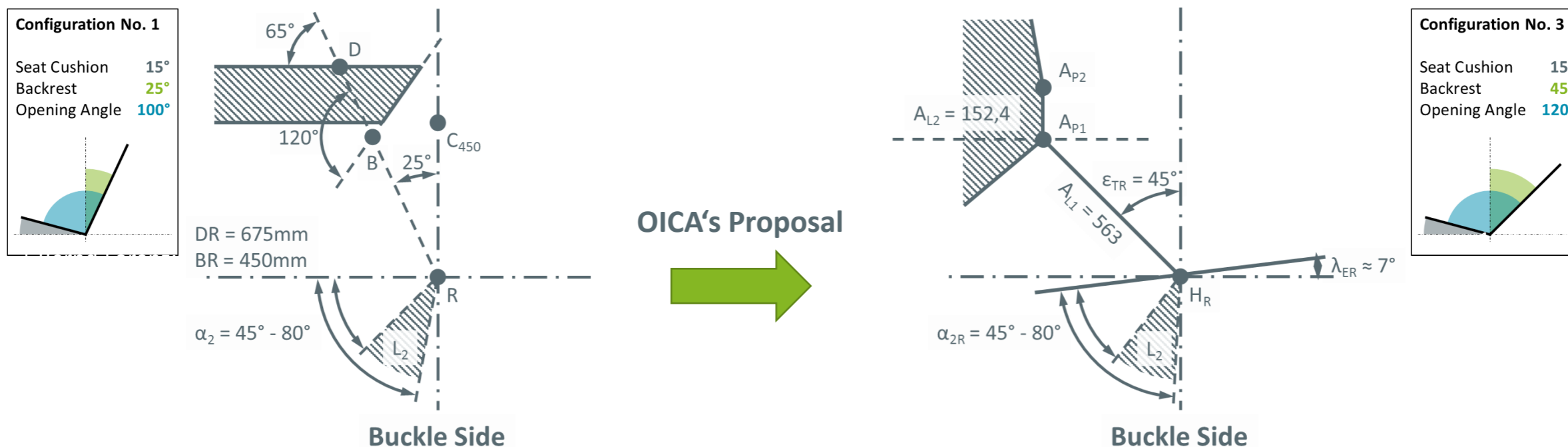

# Normal Use Position (15° // 25°)

- ▶ Permitted areas as currently defined in UNECE Regulation No. 14
  - ▶ BR assumed to be 450 mm

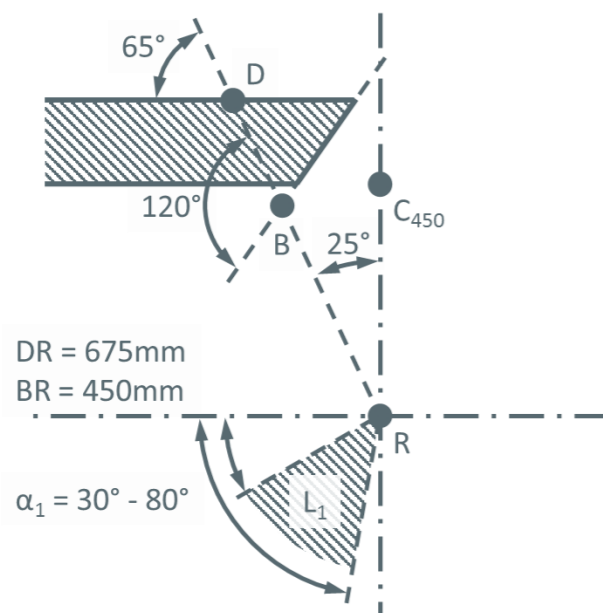

Other than Buckle Side

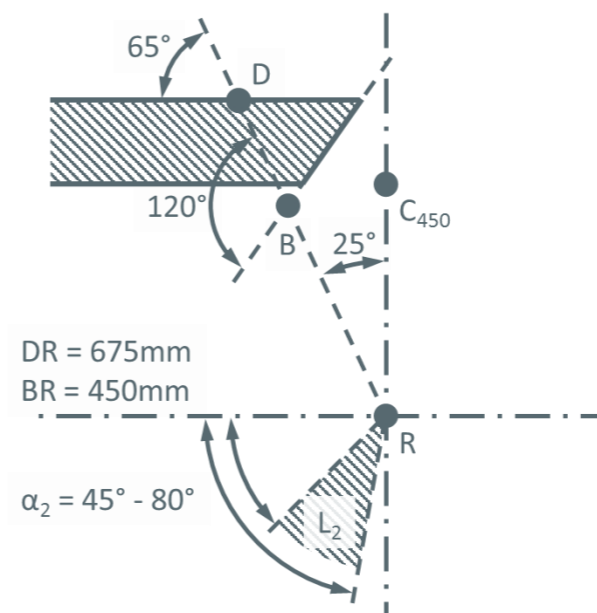

Buckle Side

## Configuration No. 1

Seat Cushion 15°  
Backrest 25°  
Opening Angle 100°

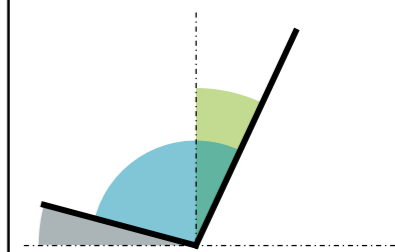

# Normal Use Position (15° // 25°)

**H-Point Manikin**

Seat Cushion	15°
Backrest	25°
Opening Angle	100°

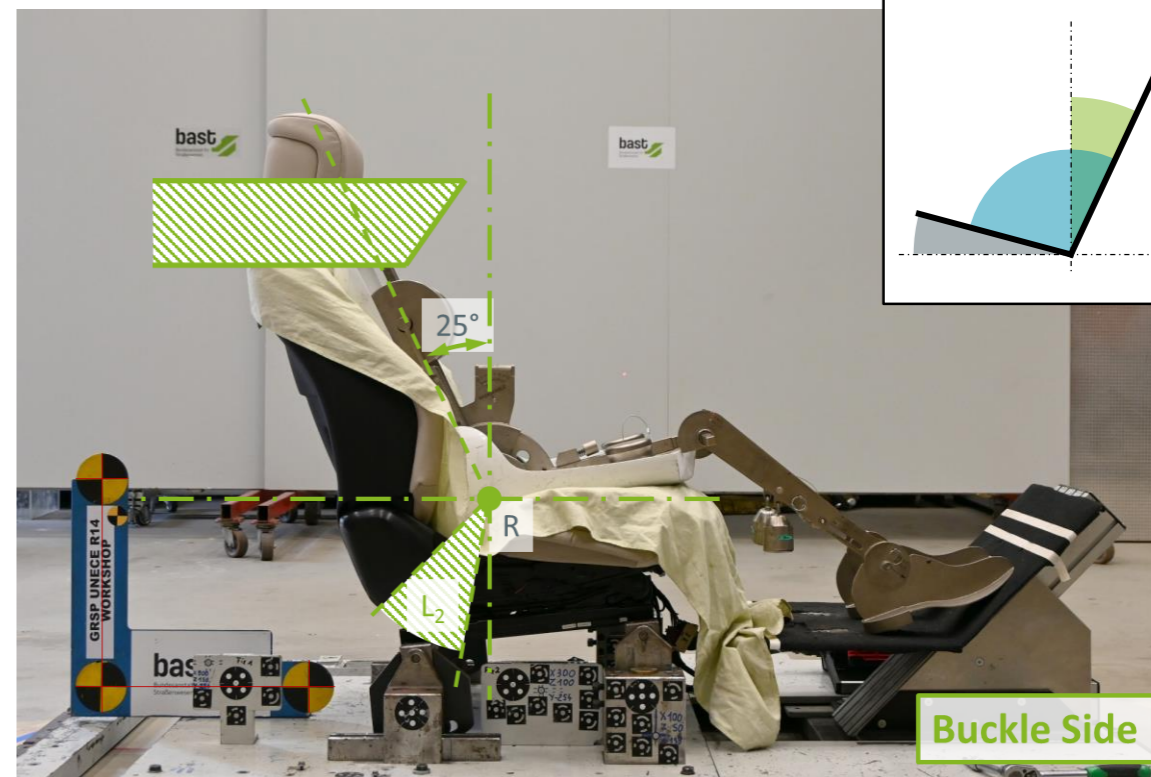
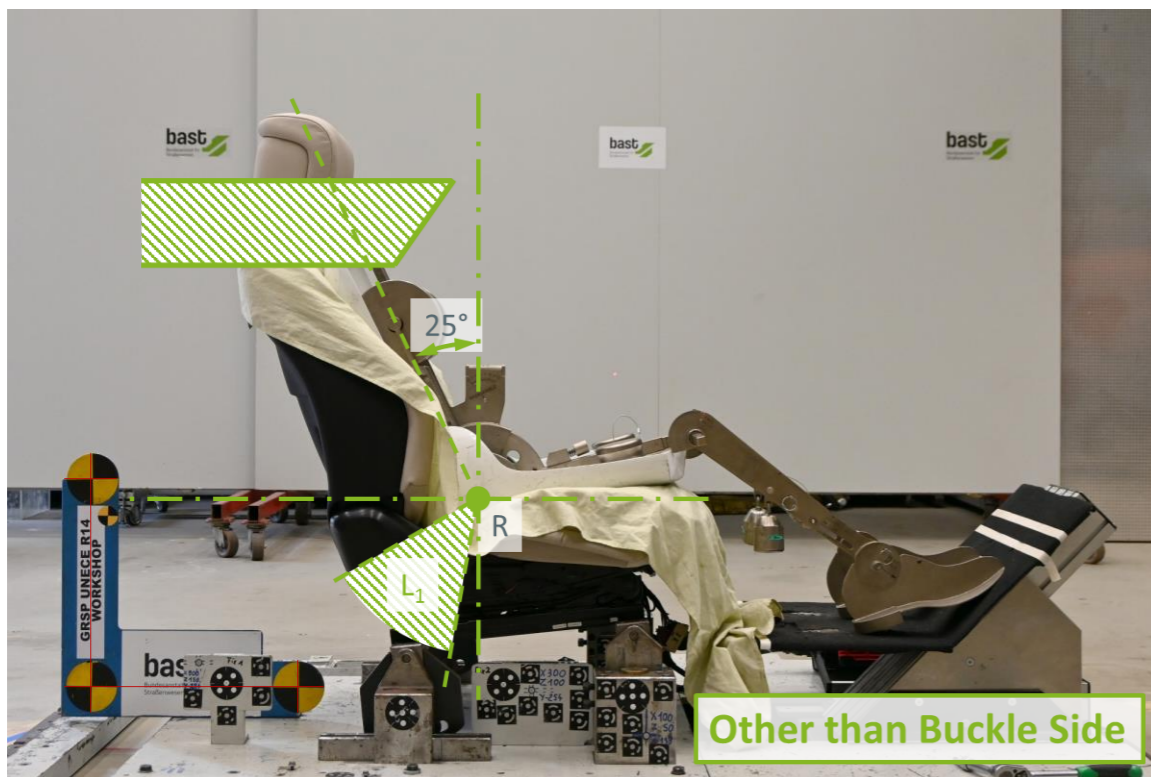

# Normal Use Position (15° // 25°)

## Hybrid III 5<sup>th</sup> Female

Seat Cushion 15°  
Backrest 25°  
Opening Angle 100°

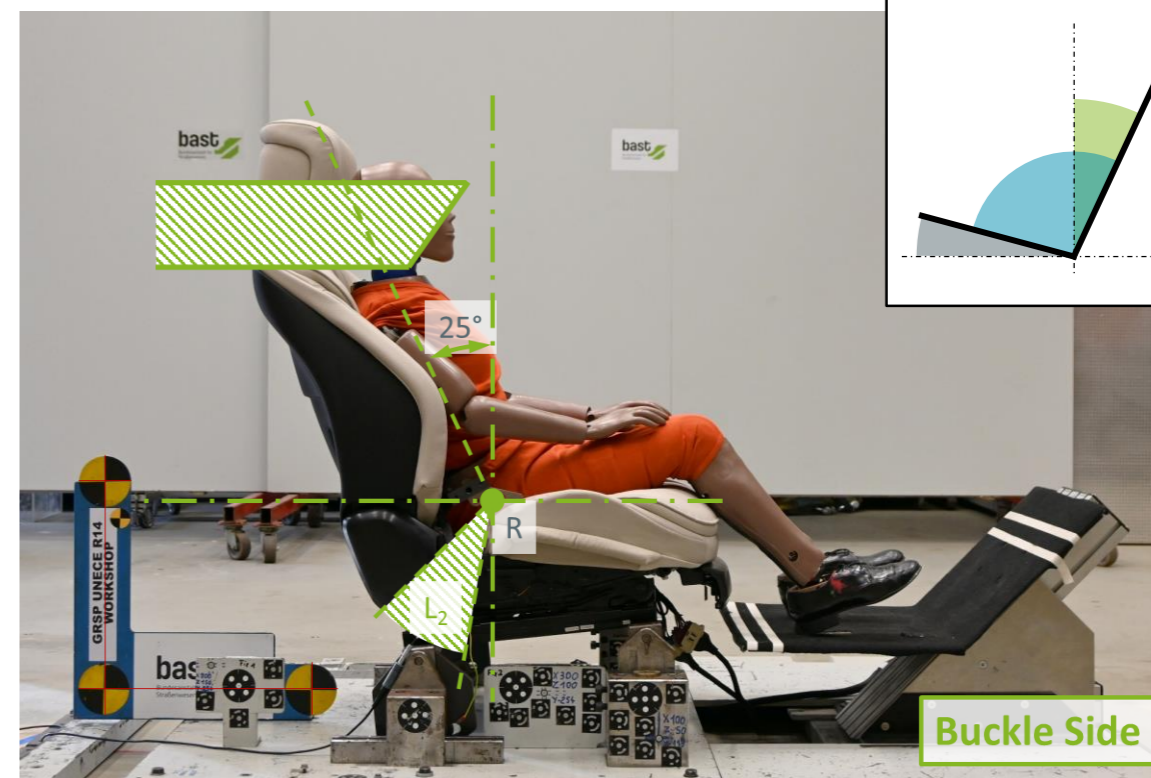
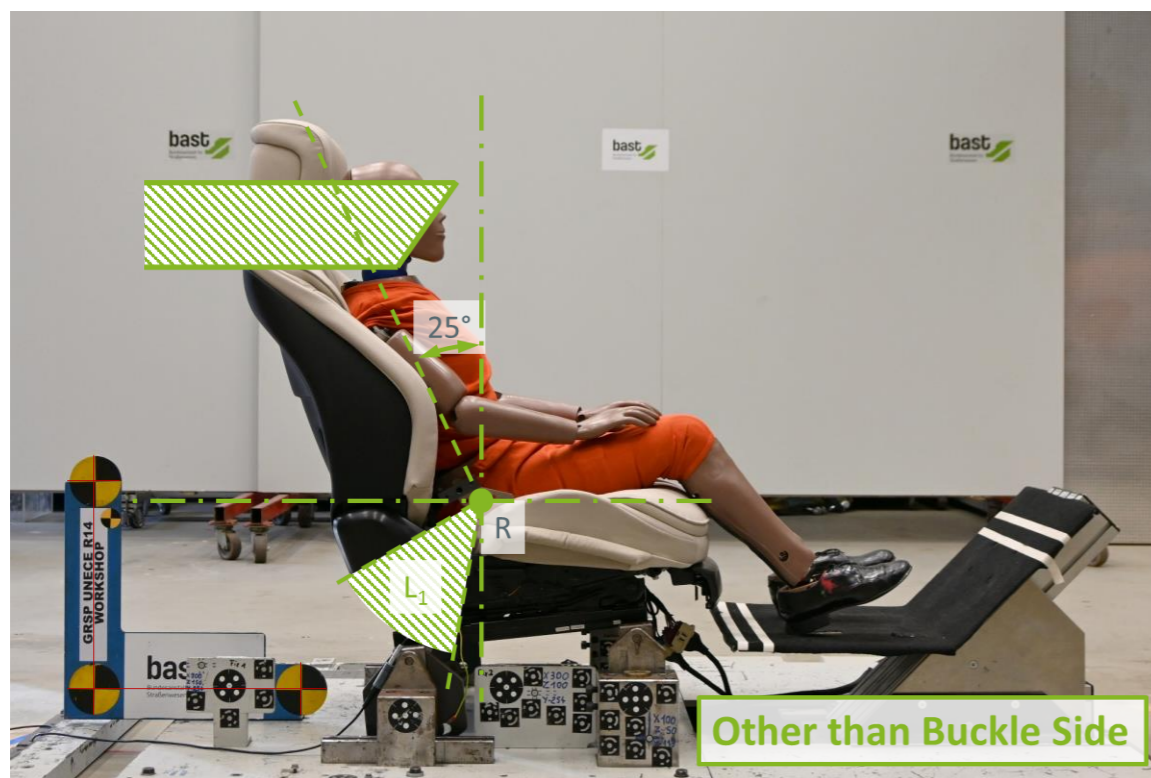
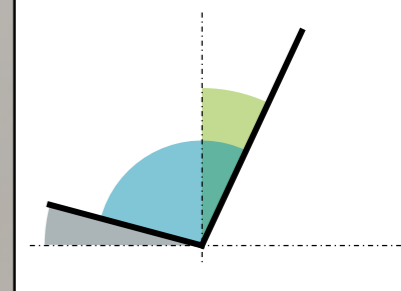

# Normal Use Position (15° // 25°)

**Hybrid III 50<sup>th</sup> Male**

Seat Cushion	15°
Backrest	25°
Opening Angle	100°

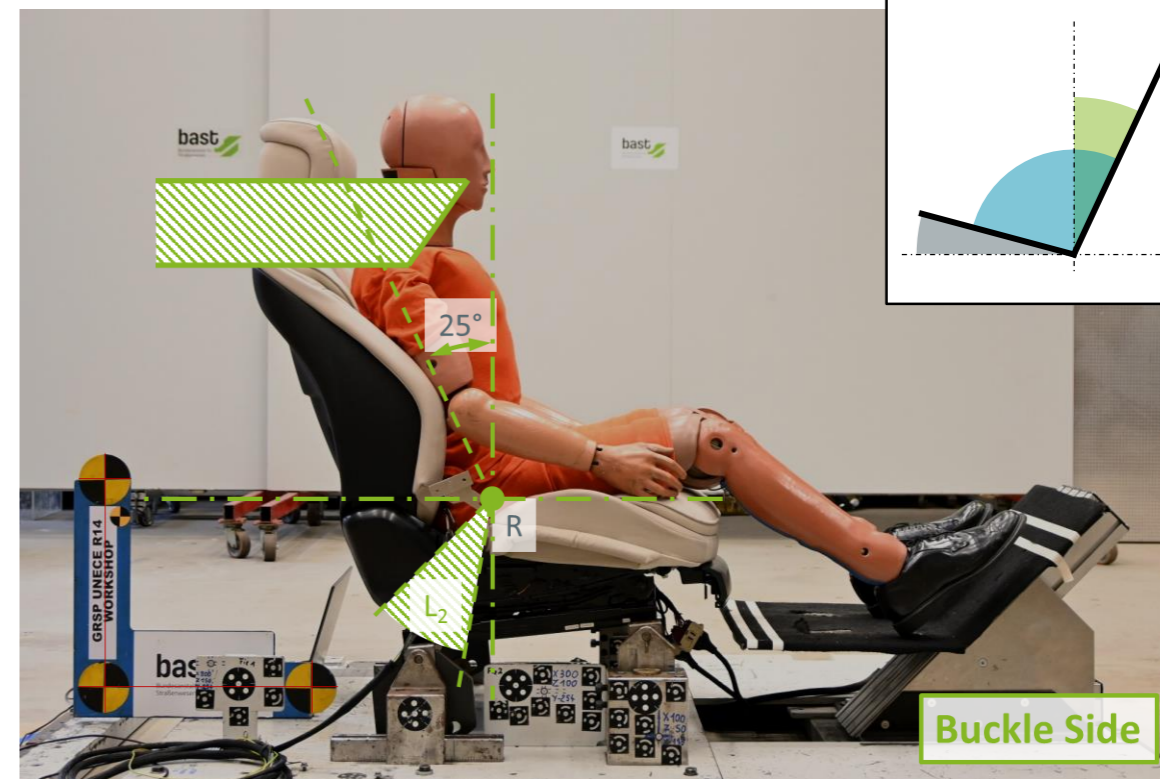
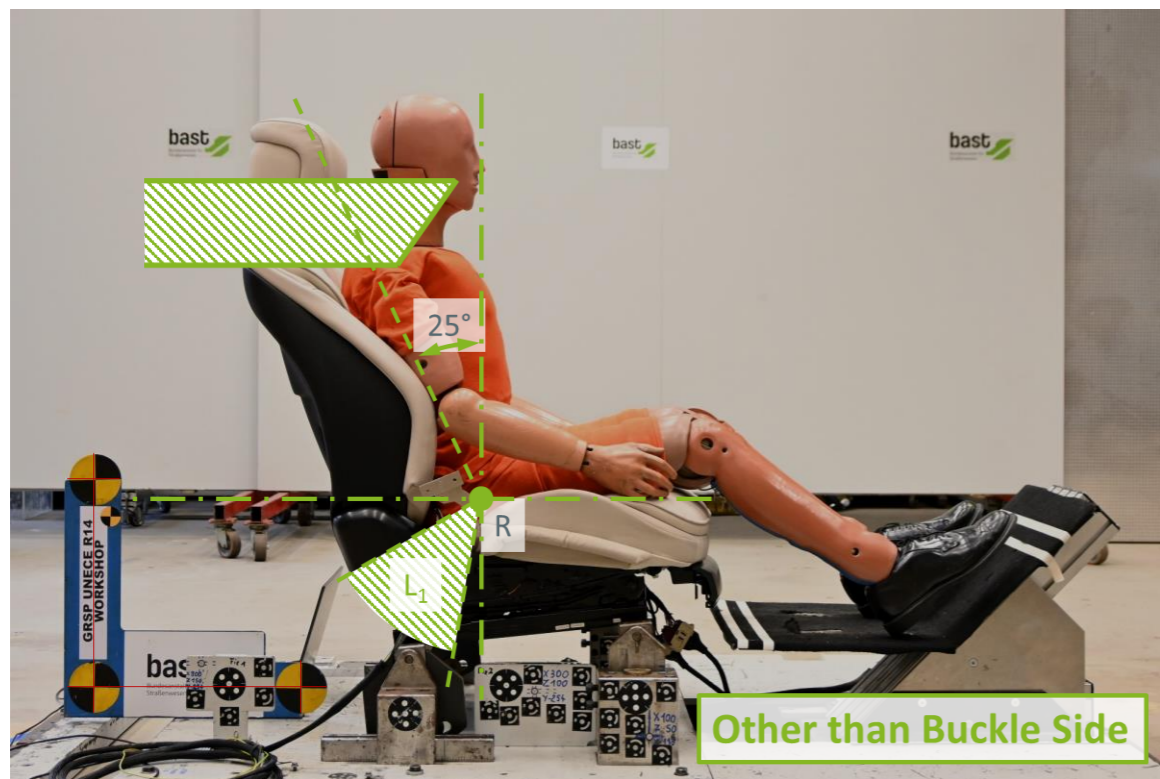

# Normal Use Position (15° // 25°)

## Hybrid III 95<sup>th</sup> Male

Seat Cushion 15°  
Backrest 25°  
Opening Angle 100°

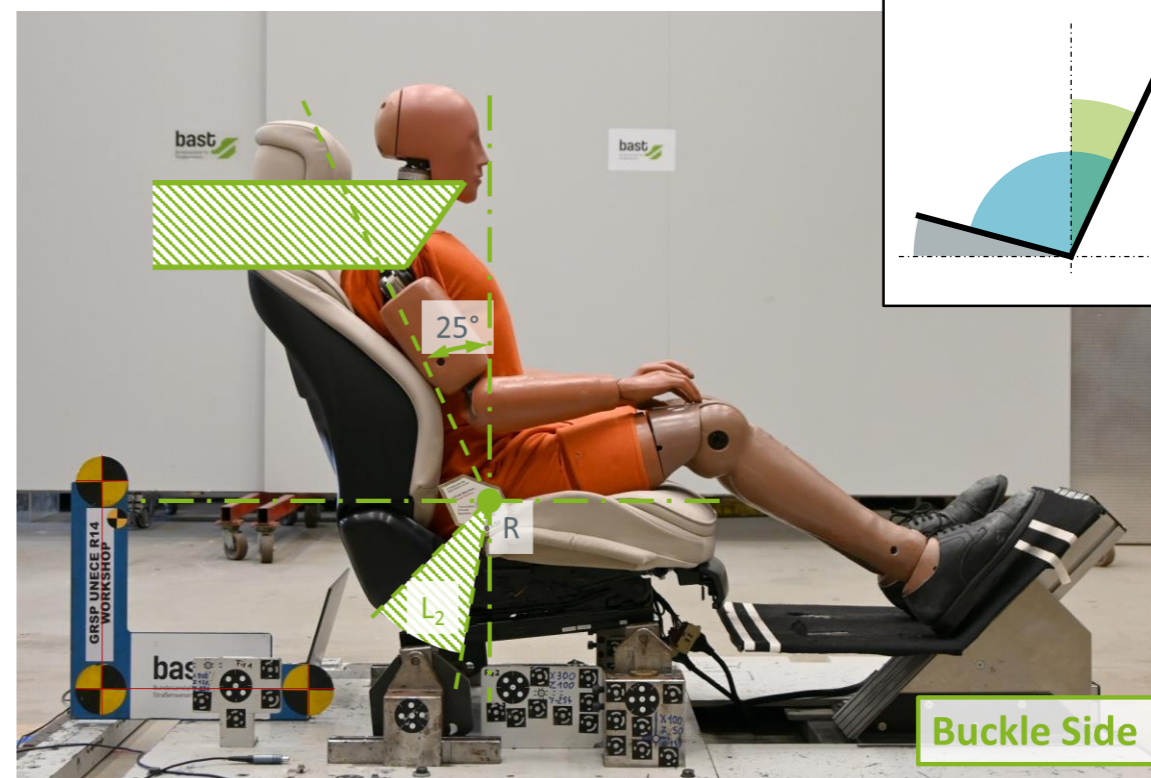
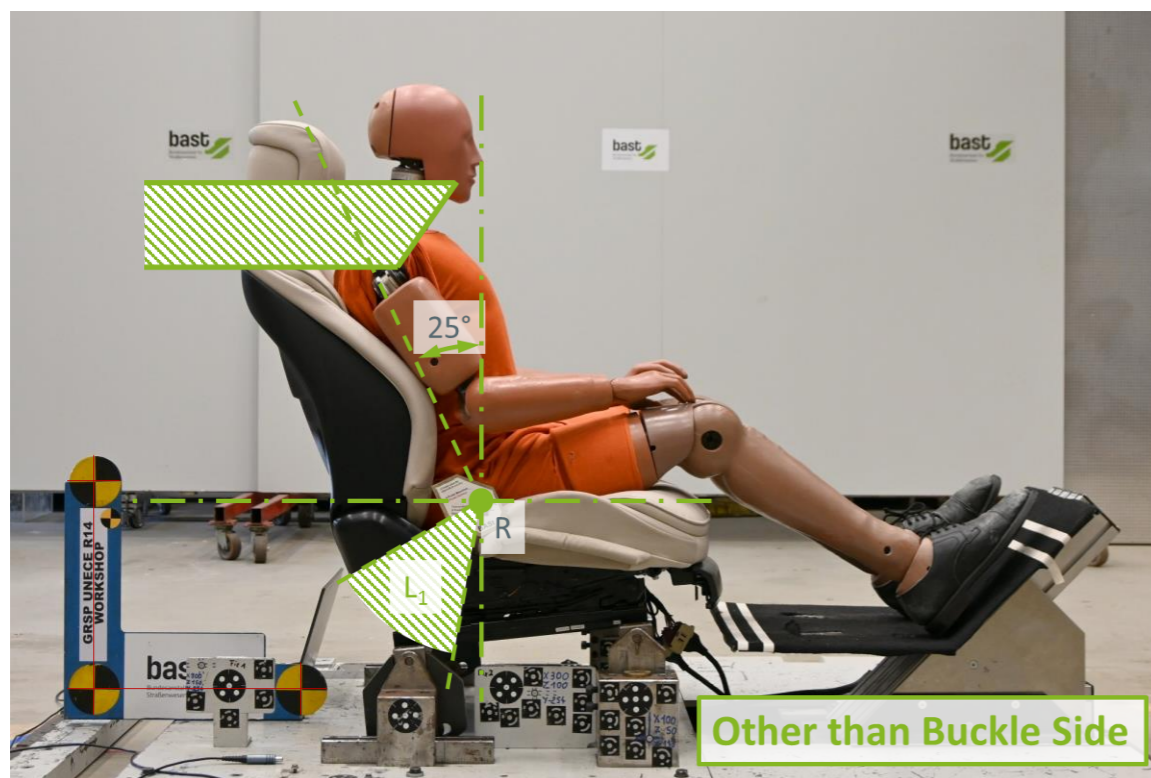
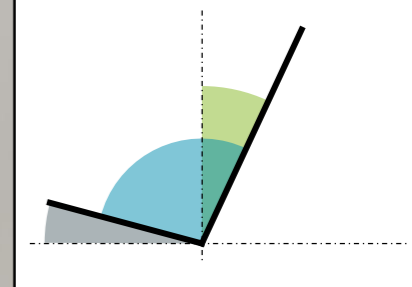



# Normal Use Position (15° // 25°)

## THOR-50M

Seat Cushion 15°  
Backrest 25°  
Opening Angle 100°

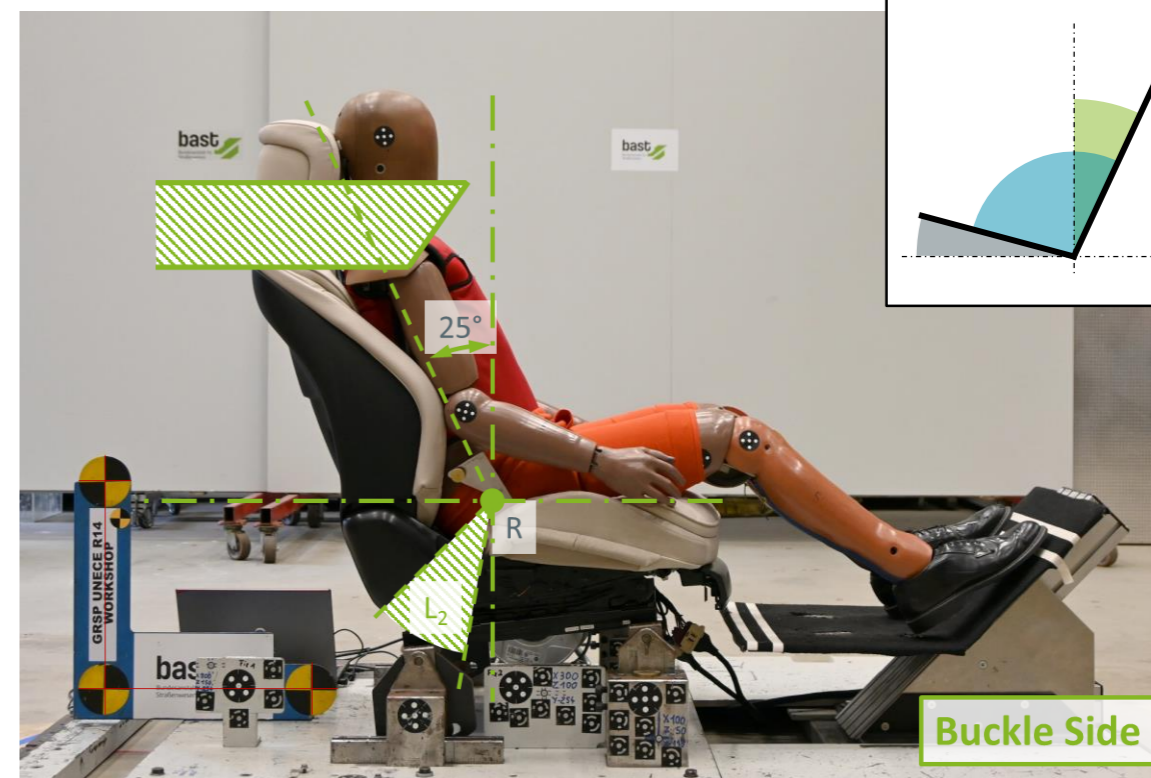
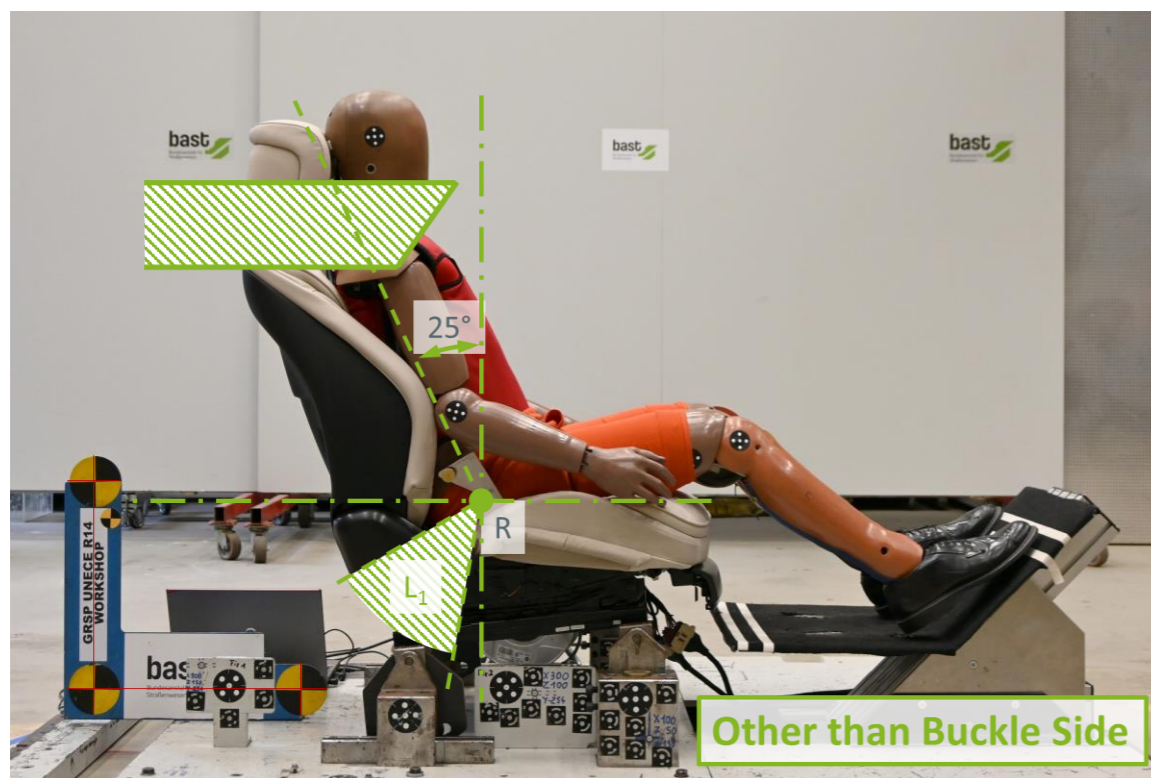
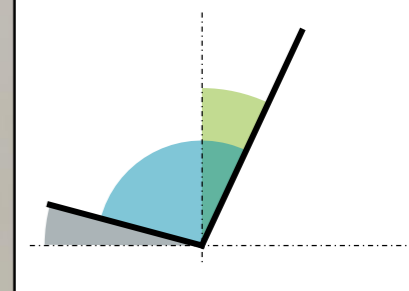

# Normal Use Position (15° // 25°)

**THOR-RS-50M**

Seat Cushion	15°
Backrest	25°
Opening Angle	100°

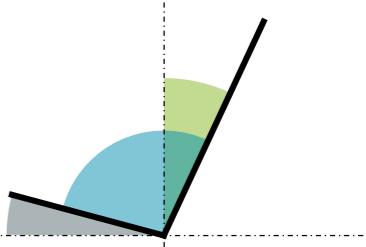
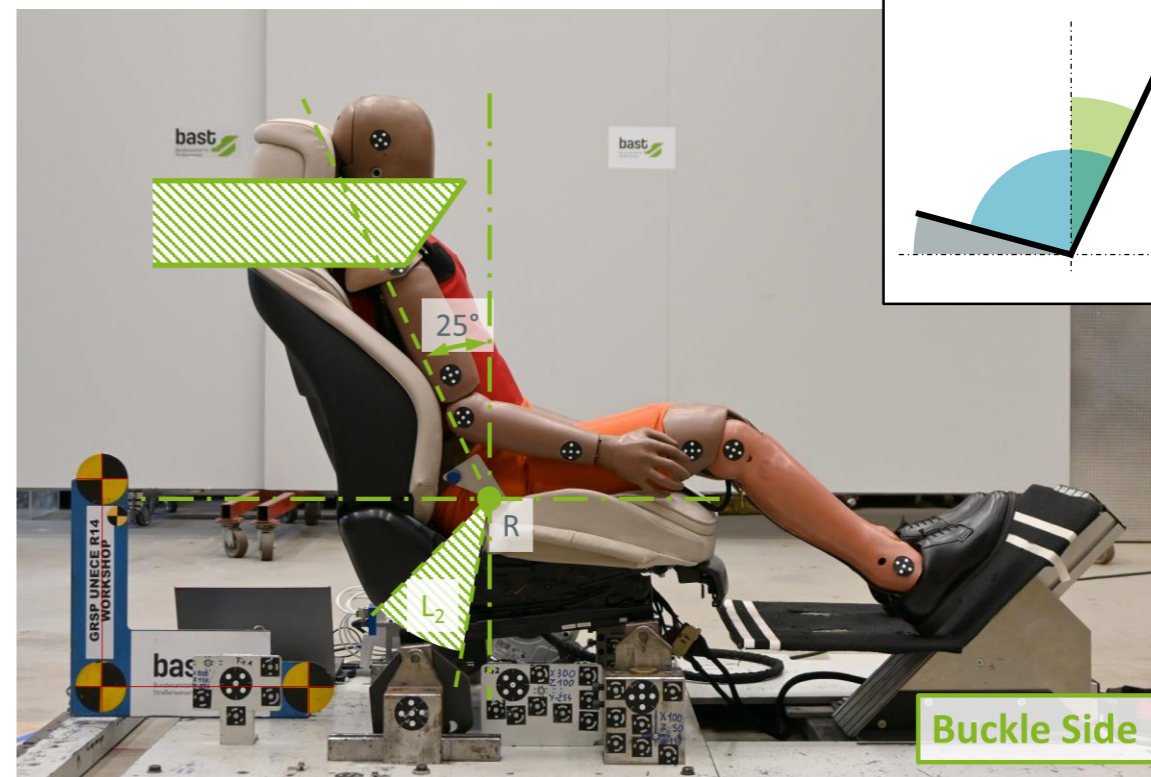
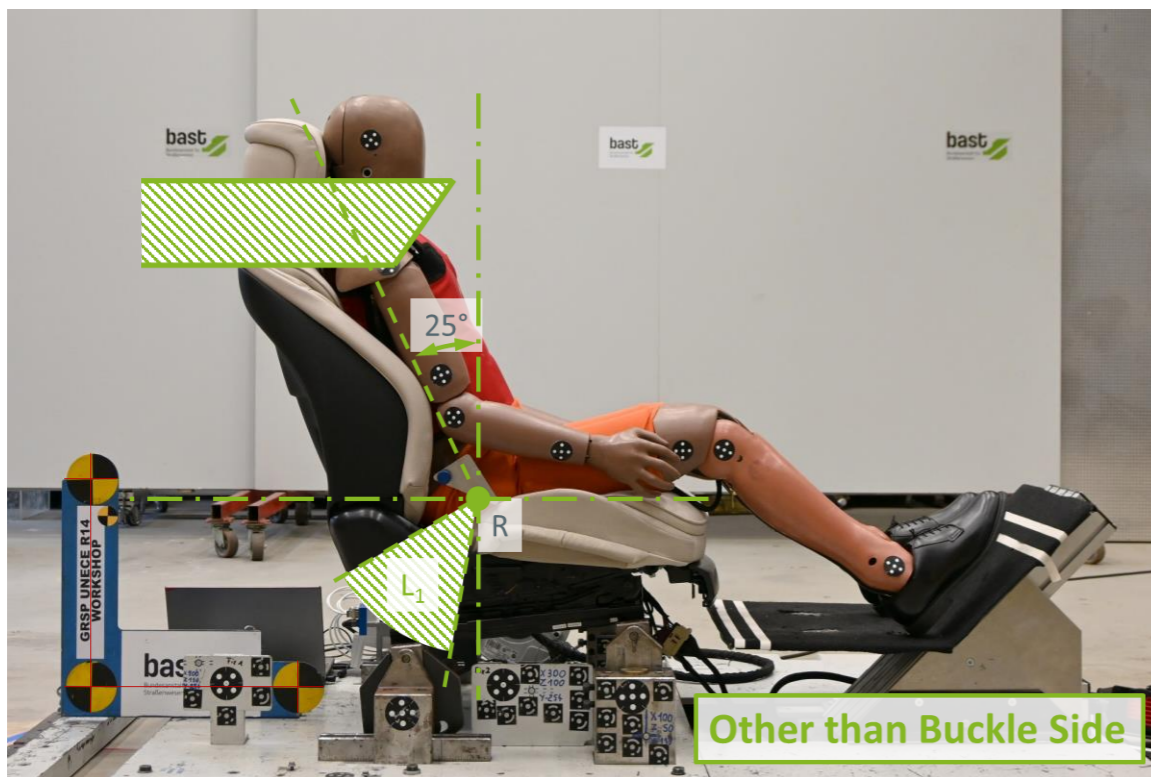
# Normal Use Position (15° // 25°)

**Male Participant**  
 Height: 172 cm  
 Seat Cushion 15°  
 Backrest 25°  
 Opening Angle 100°

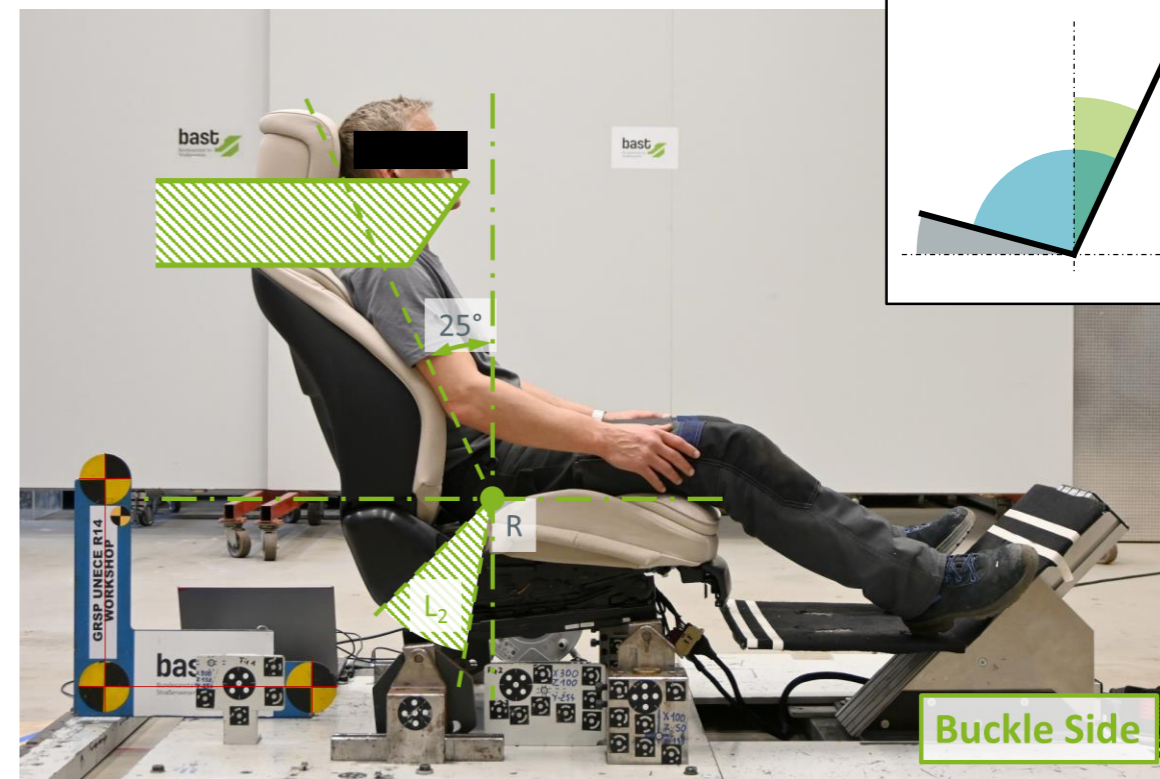
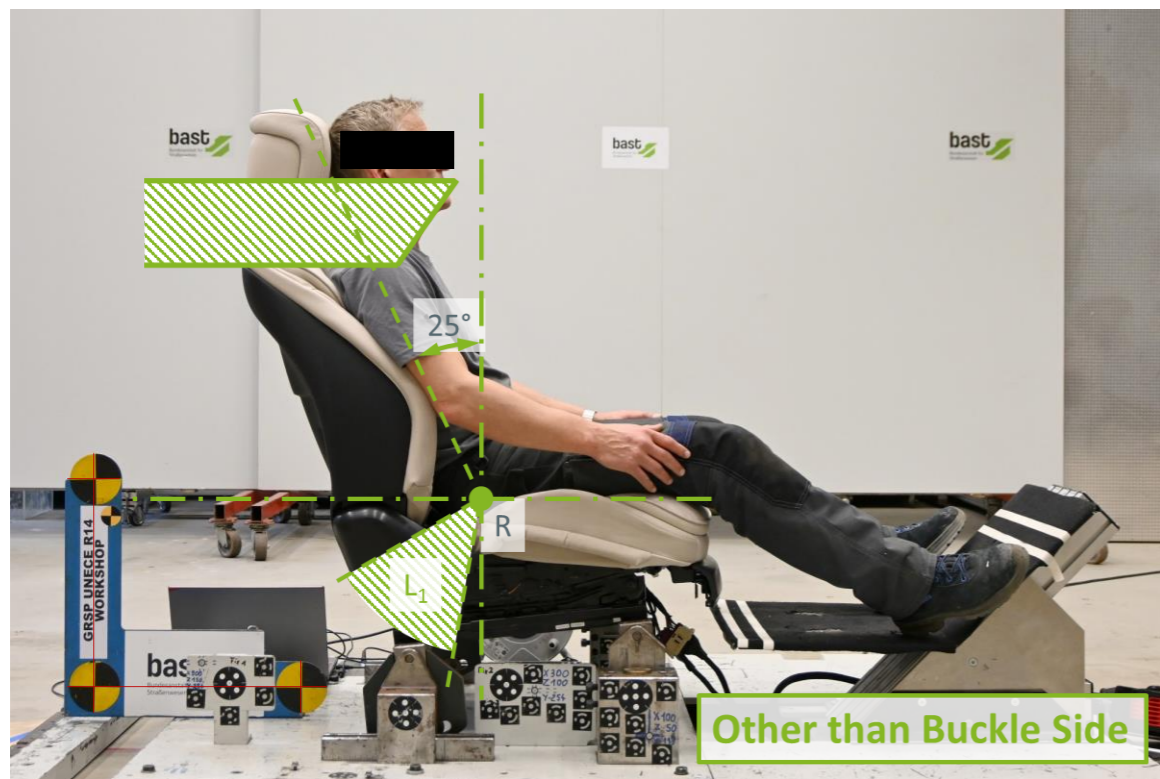

# Normal Use Position (15° // 25°)

**Male Participant**  
Height: 193 cm  
Seat Cushion 15°  
Backrest 25°  
Opening Angle 100°

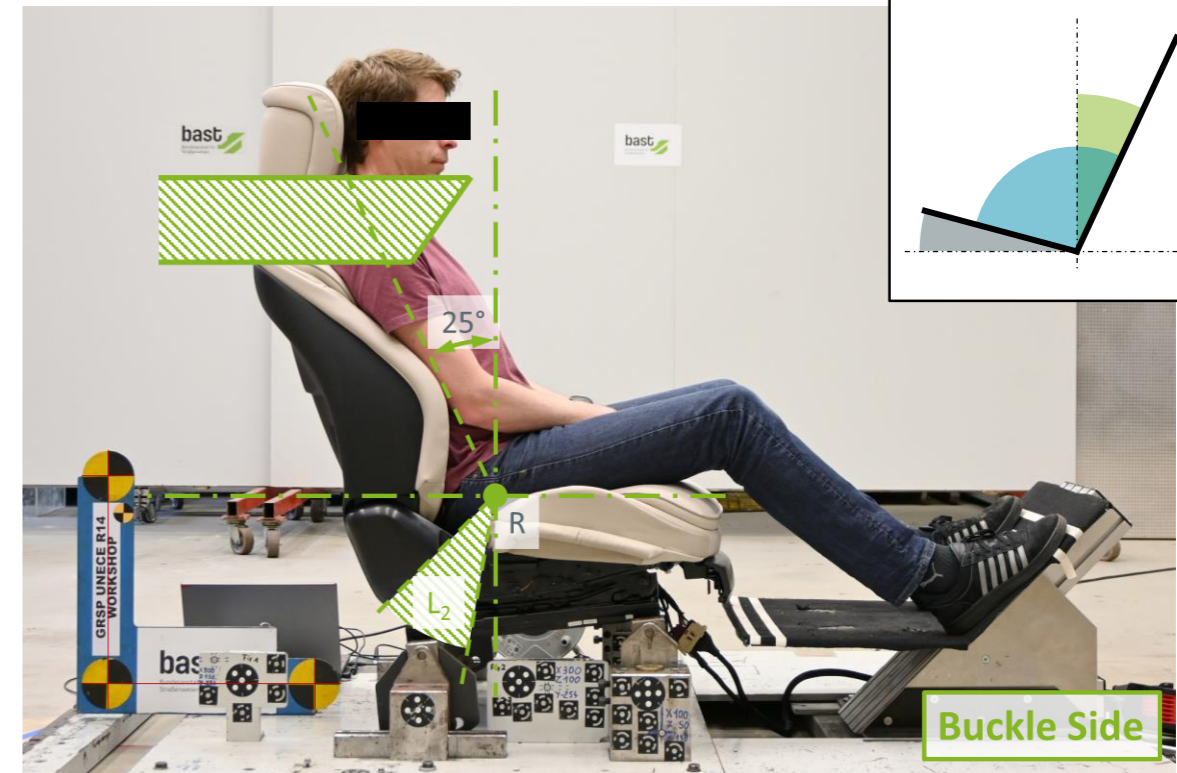
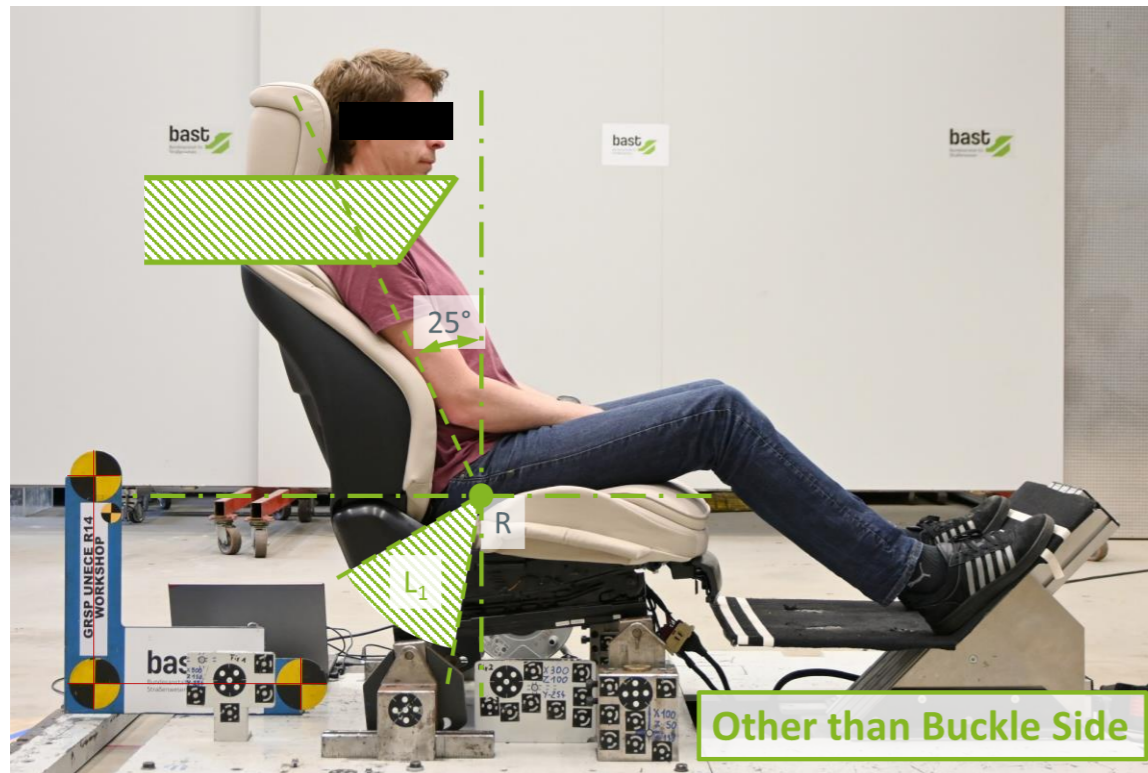
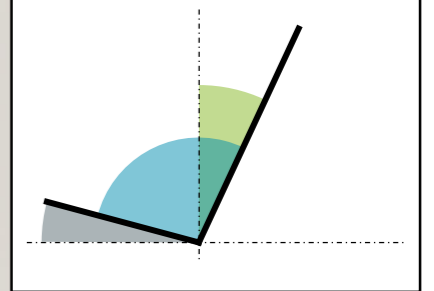

# Extended Use Position (15° // 35°)

- ▶ Backrest inclination is changed by 10° from the normal use position, while the seat cushion remains unchanged from the normal use position
  - ▶ The  $E_R$ -Plane is tilted by a third of the amount of the change in inclination of the seatback ( $\lambda_{ER} \approx 3^\circ$ )
  - ▶ The  $T_R$ -Plane is equivalent to the backrest angle ( $\epsilon_{TR} = 35^\circ$ )

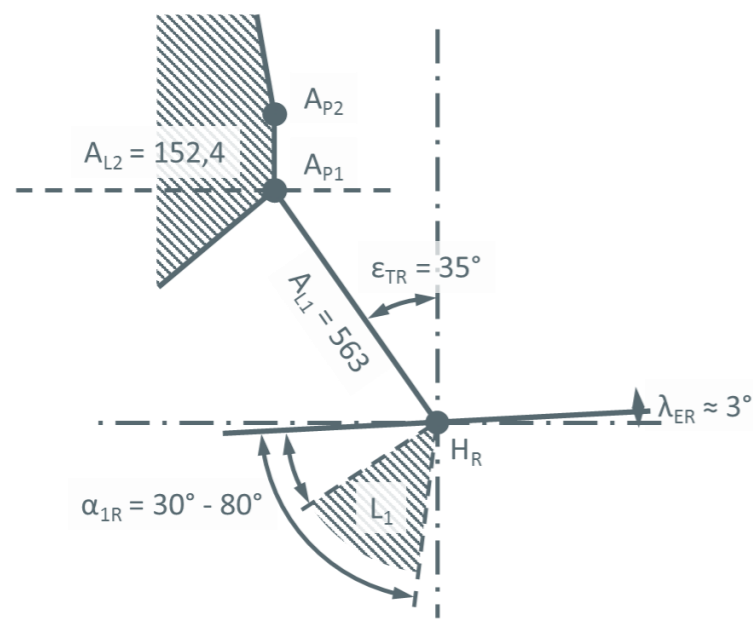

Other than Buckle Side

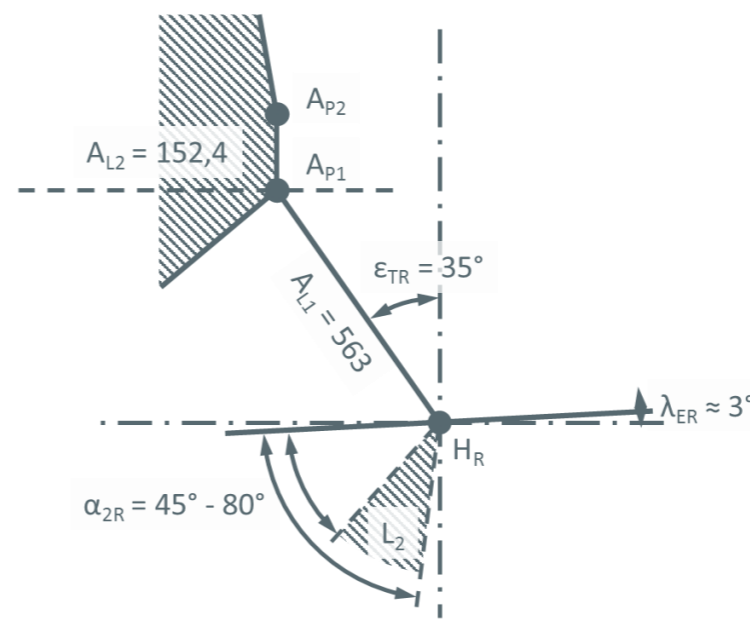

Buckle Side

## Configuration No. 2

Seat Cushion 15°  
Backrest 35°  
Opening Angle 110°

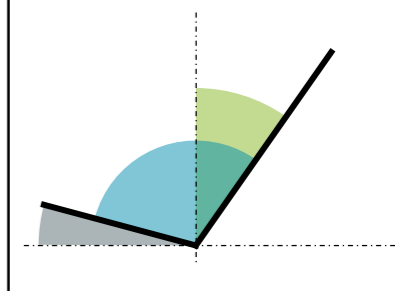

# Extended Use Position (15° // 35°)

- ▶ Similar H-Point as for normal use position (configuration no. 1)

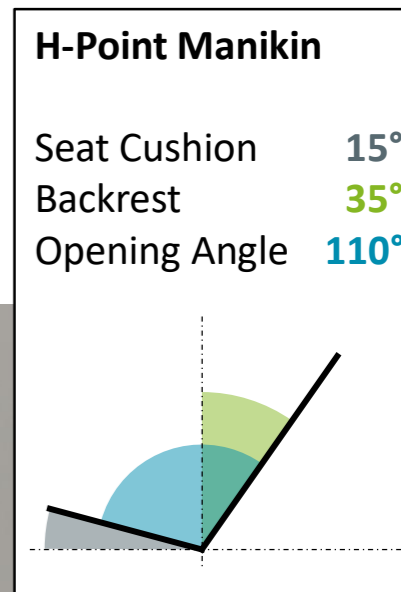
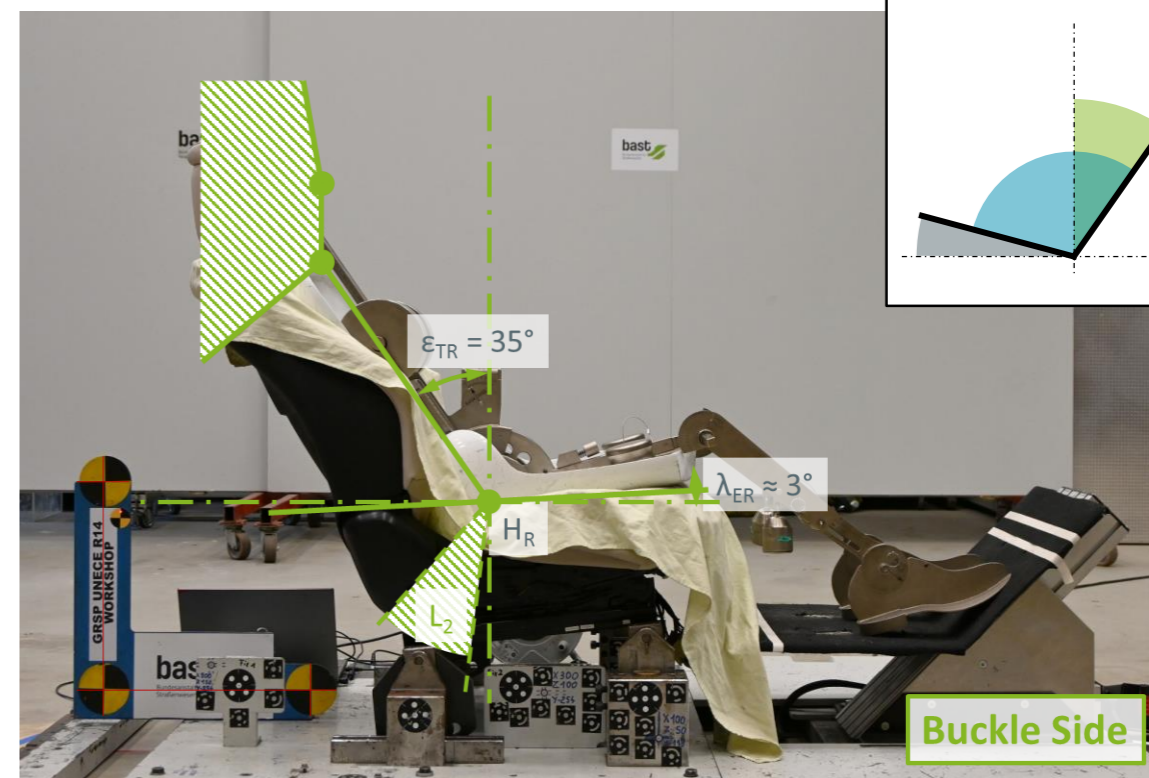
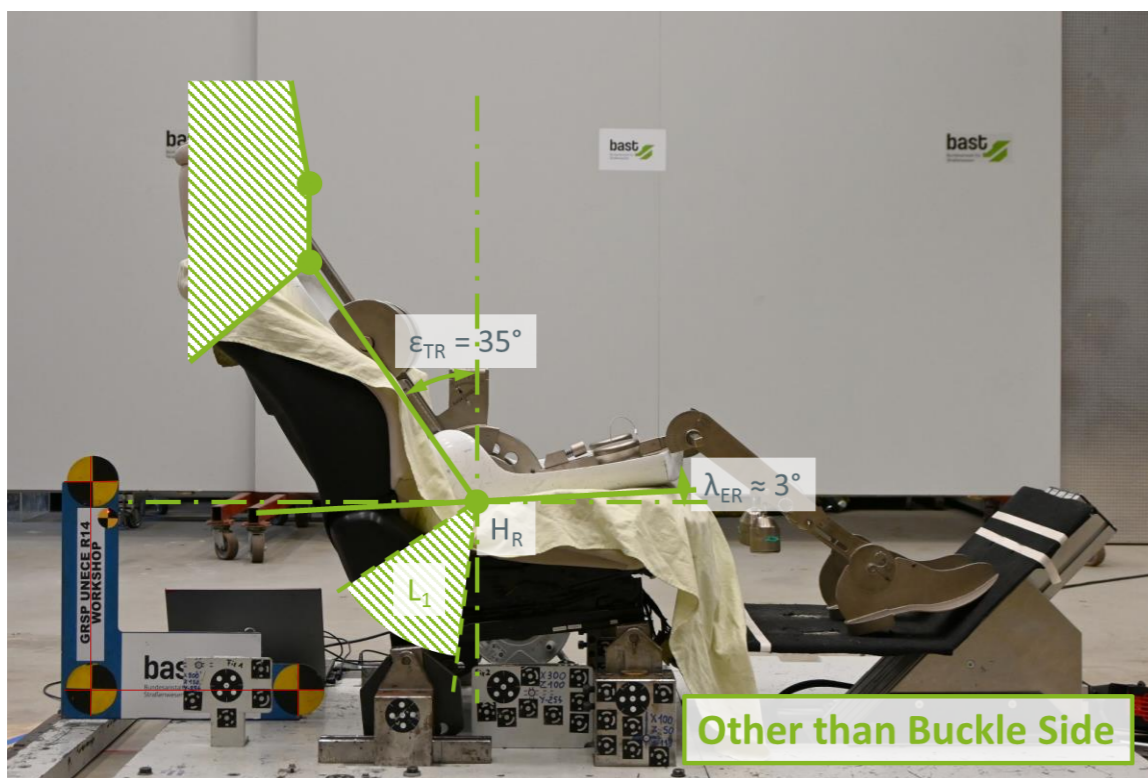

# Extended Use Position (15° // 35°)

## Hybrid III 5<sup>th</sup> Female

Seat Cushion 15°  
Backrest 35°  
Opening Angle 110°

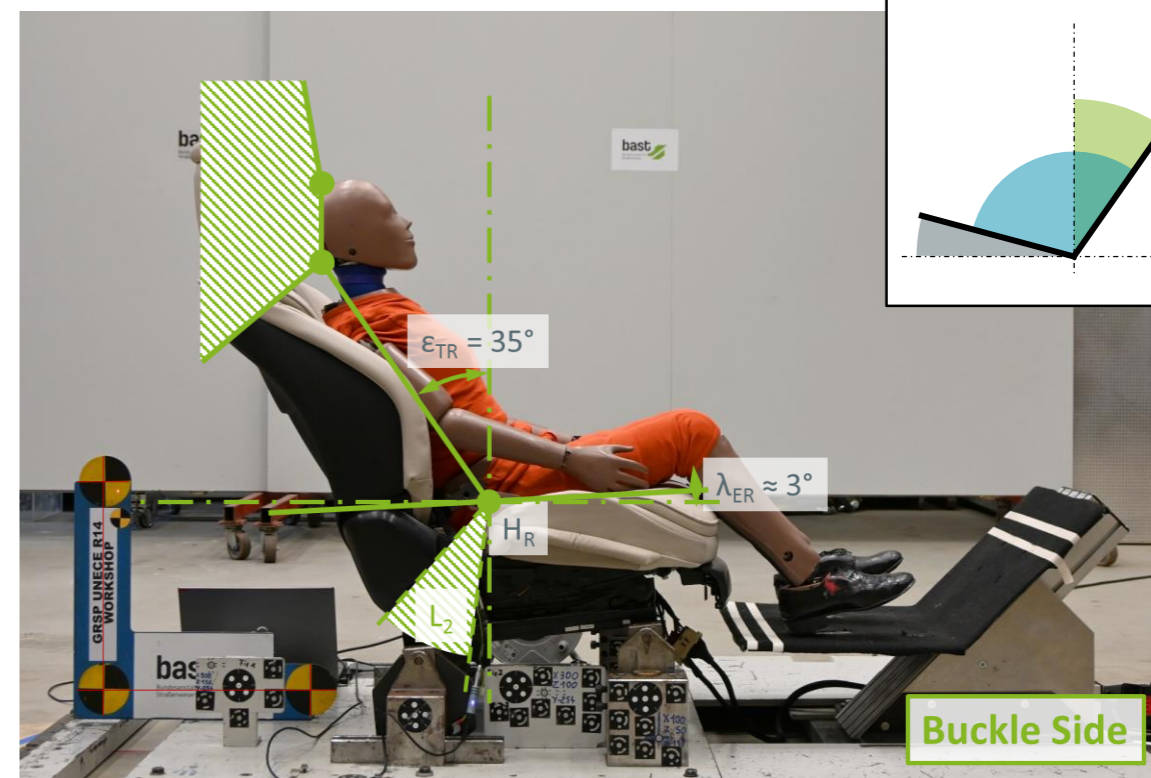
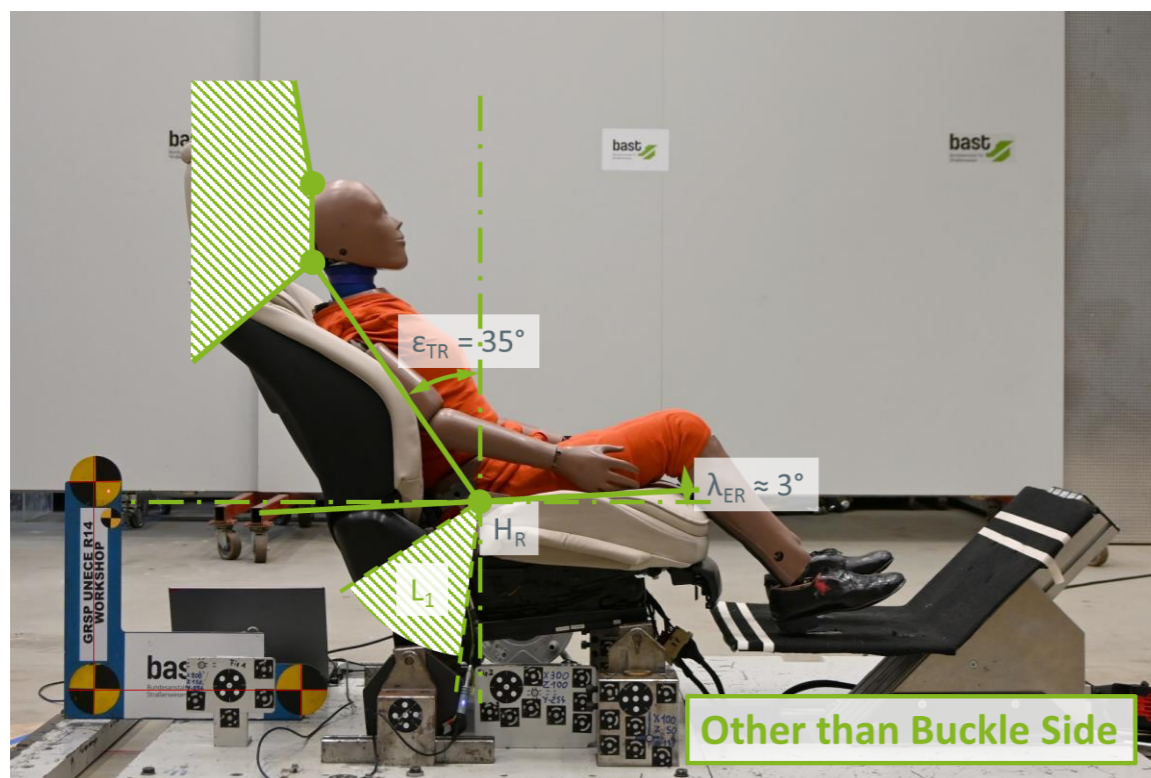
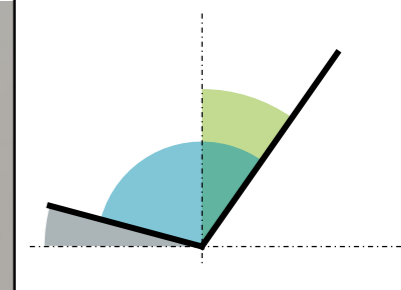

# Extended Use Position (15° // 35°)

## Hybrid III 50<sup>th</sup> Male

Seat Cushion 15°  
Backrest 35°  
Opening Angle 110°

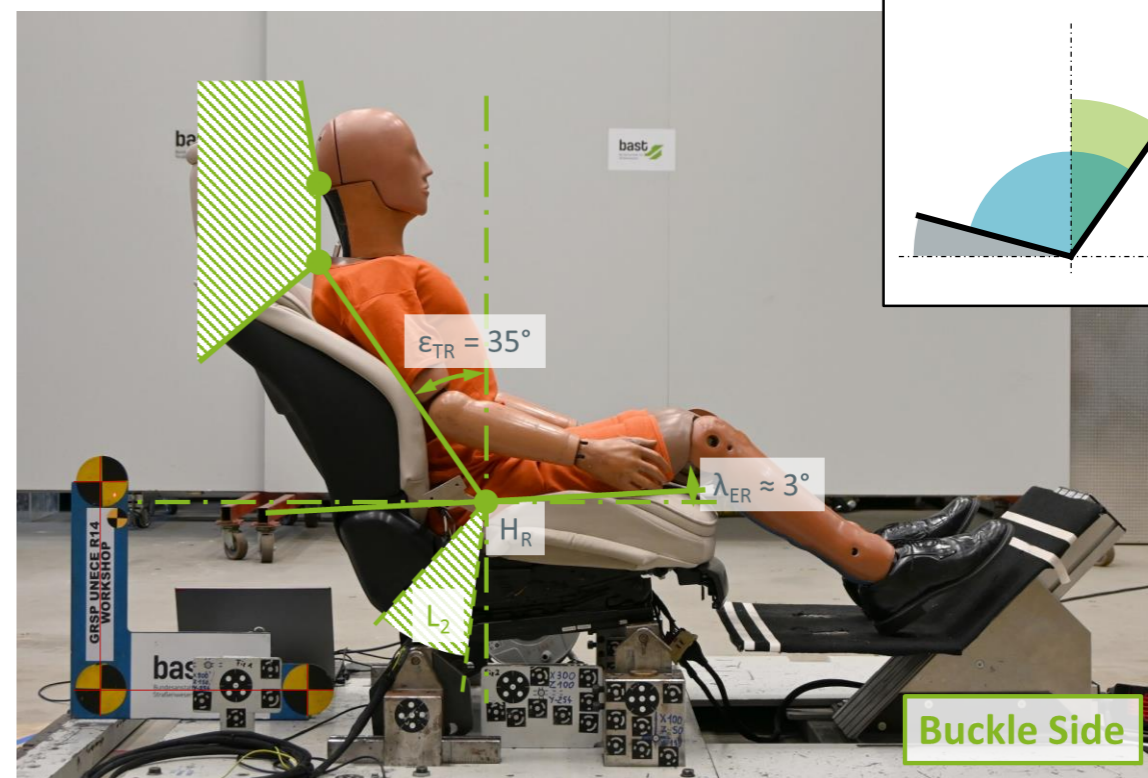
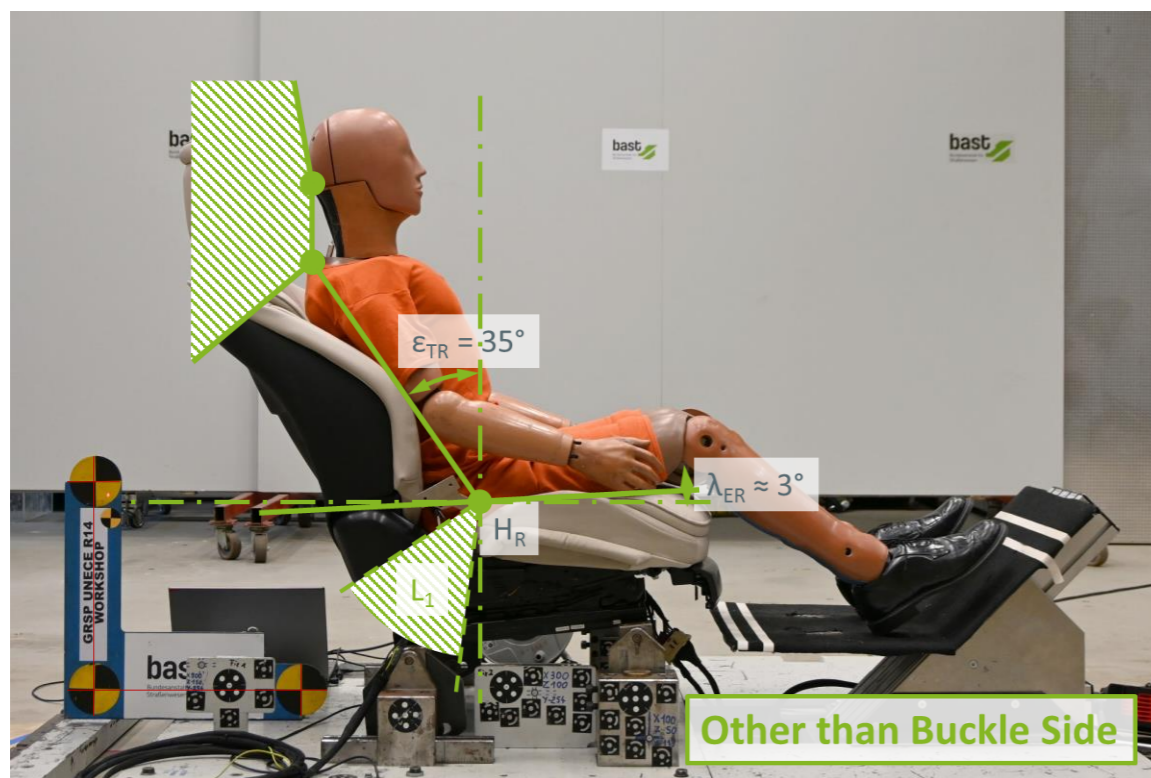
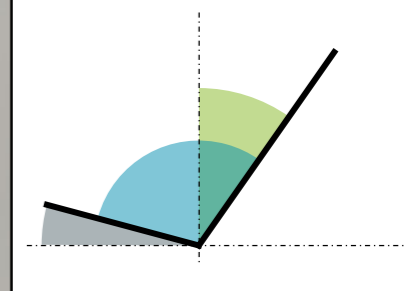







# Extended Use Position (15° // 35°)

**THOR-RS-50M**

Seat Cushion	15°
Backrest	35°
Opening Angle	110°

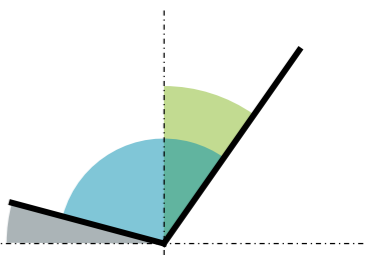
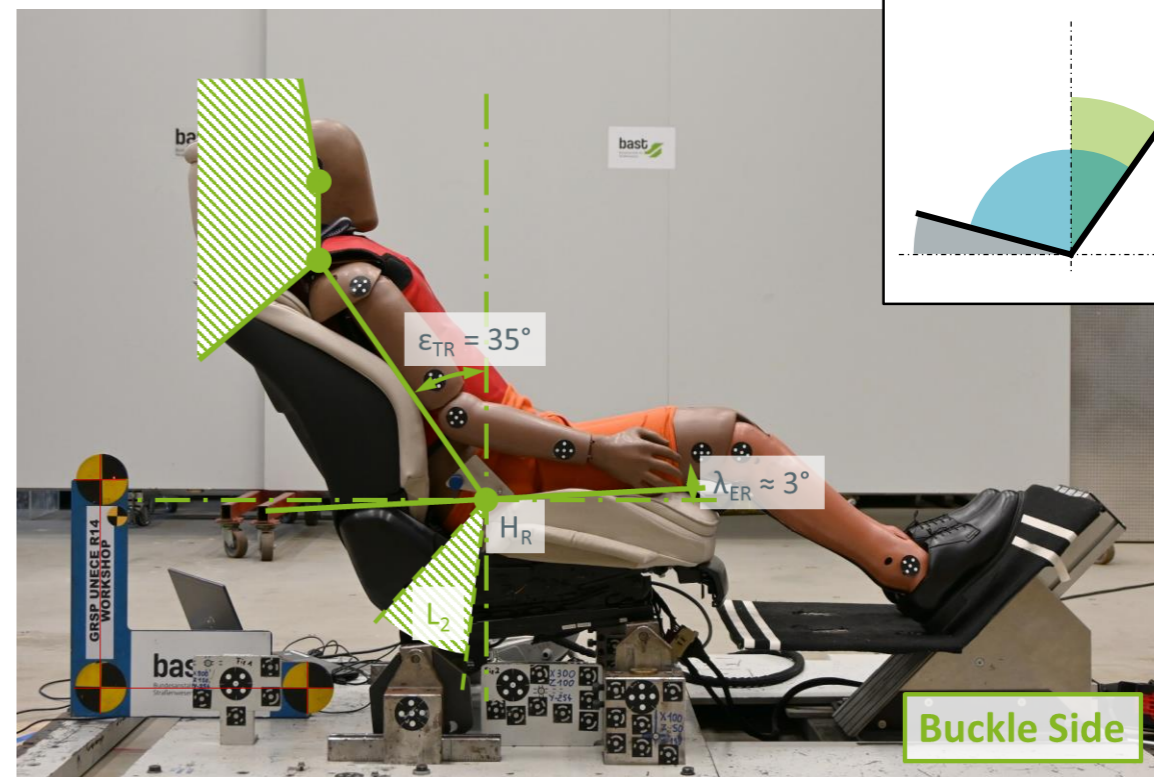
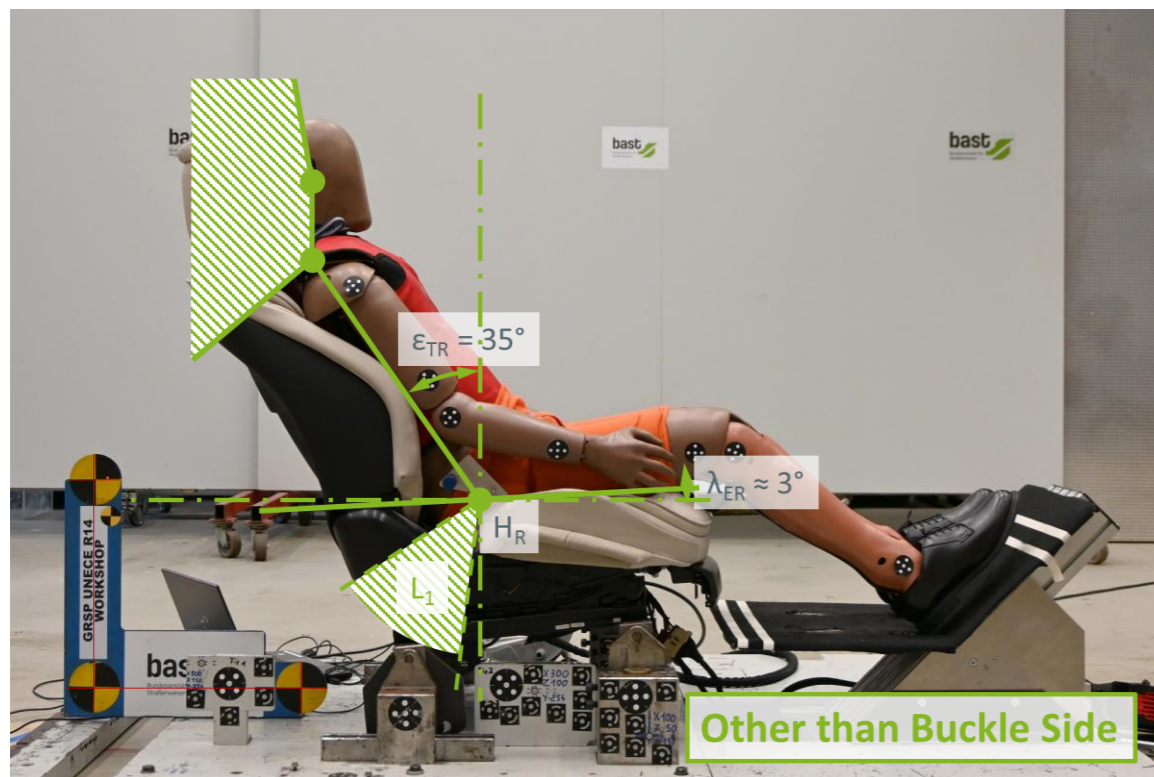
# Extended Use Position (15° // 35°)

**Male Participant**  
Height: 172 cm  
Seat Cushion 15°  
Backrest 35°  
Opening Angle 110°

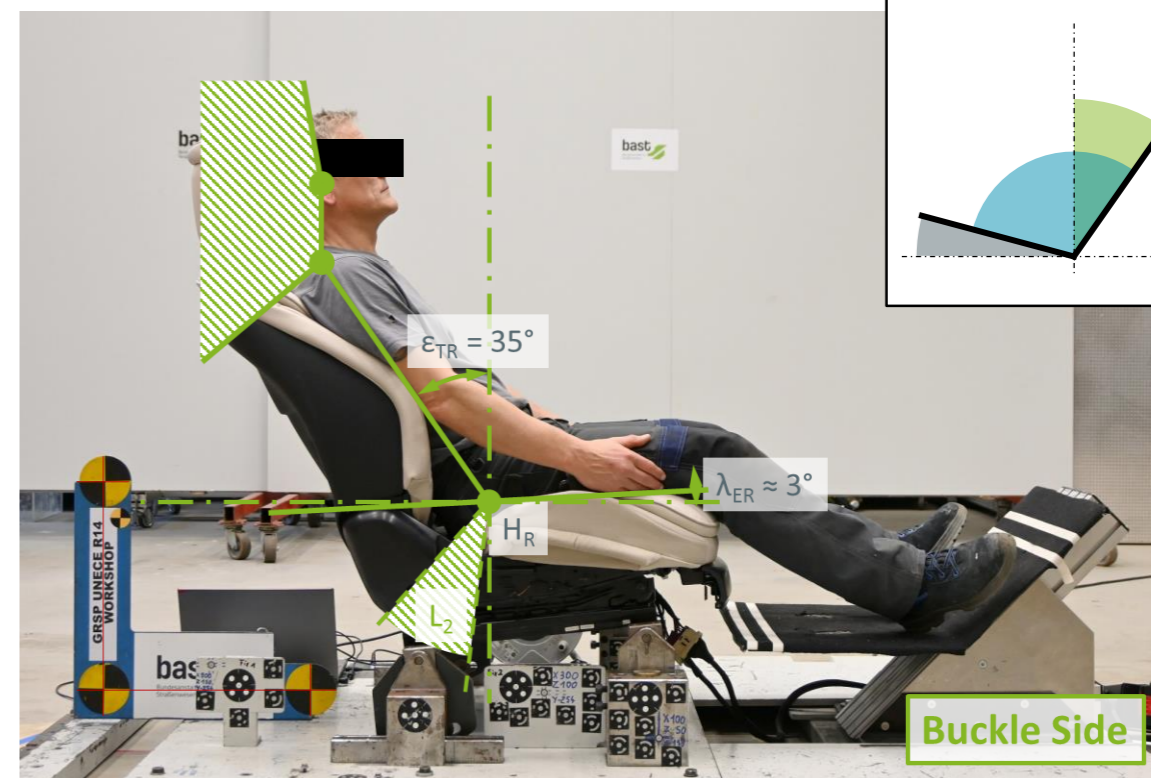
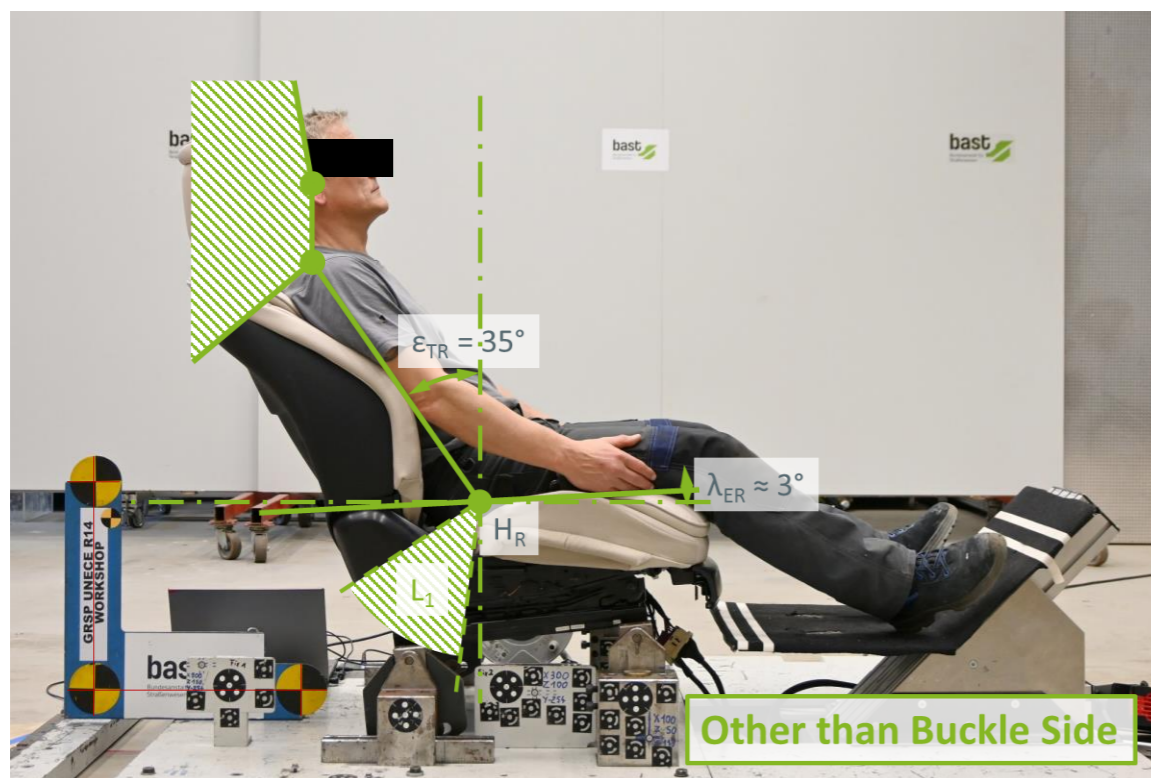
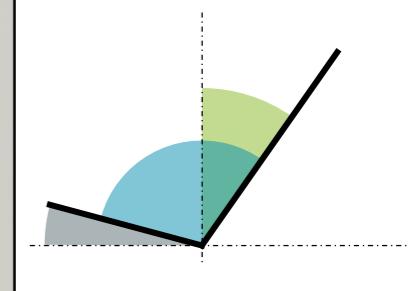

# Extended Use Position (15° // 35°)

**Male Participant**  
Height: 193 cm  
Seat Cushion 15°  
Backrest 35°  
Opening Angle 110°

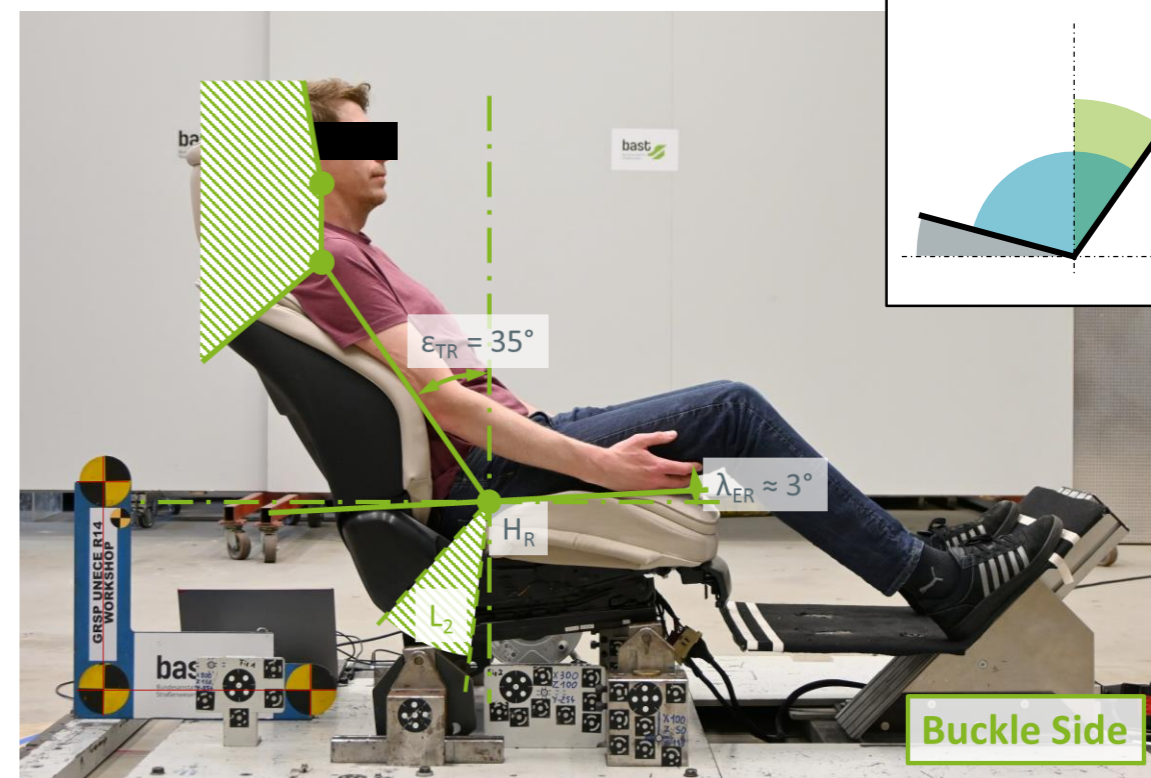
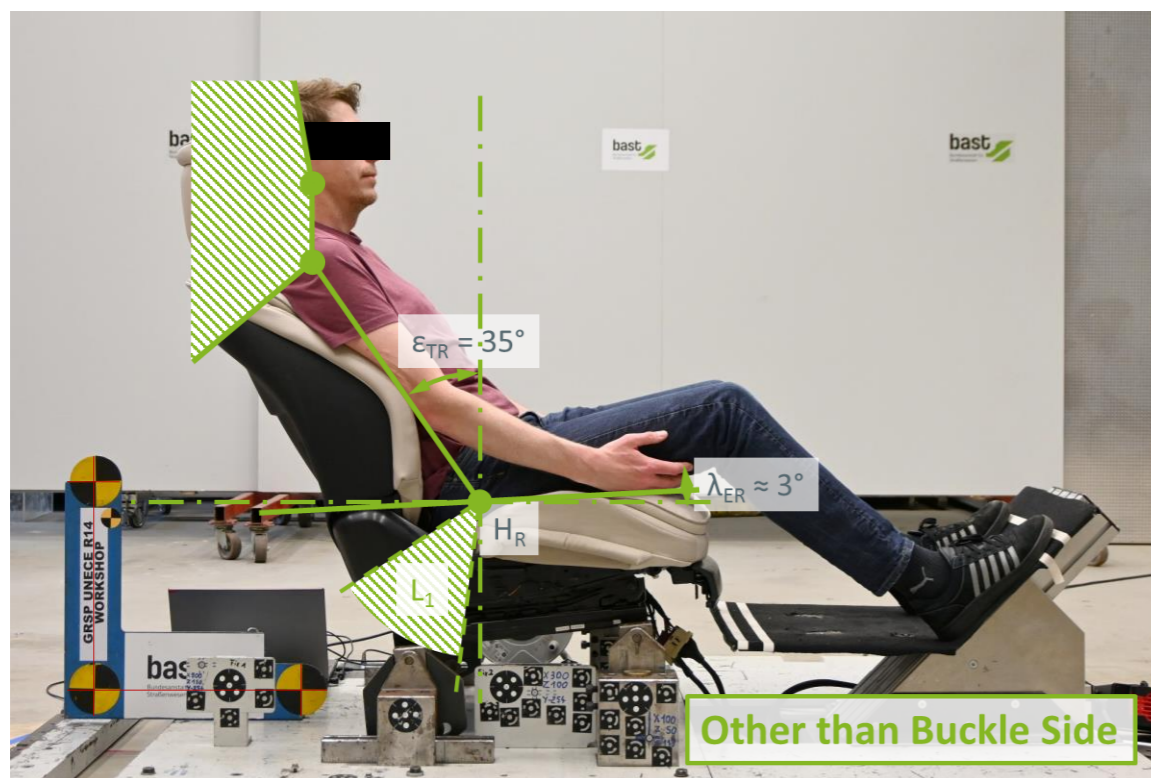
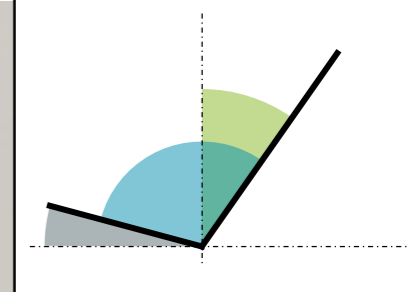

# Extended Use Position (15° // 45°)

- ▶ Backrest inclination is changed by 20° from the normal use position, while the seat cushion remains unchanged from the normal use position
  - ▶ The  $E_R$ -Plane is tilted by a third of the amount of the change in inclination of the seatback ( $\lambda_{ER} \approx 7^\circ$ )
  - ▶ The  $T_R$ -Plane is equivalent to the backrest angle ( $\epsilon_{TR} = 45^\circ$ )

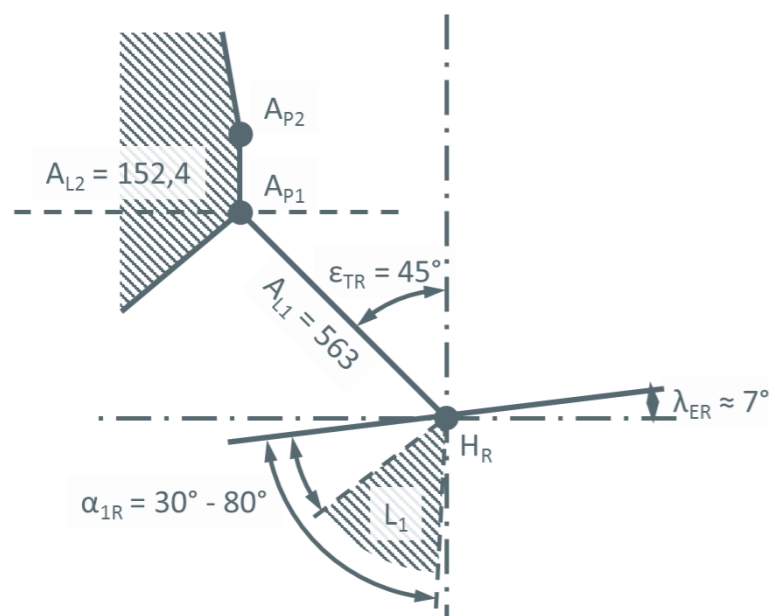

Other than Buckle Side

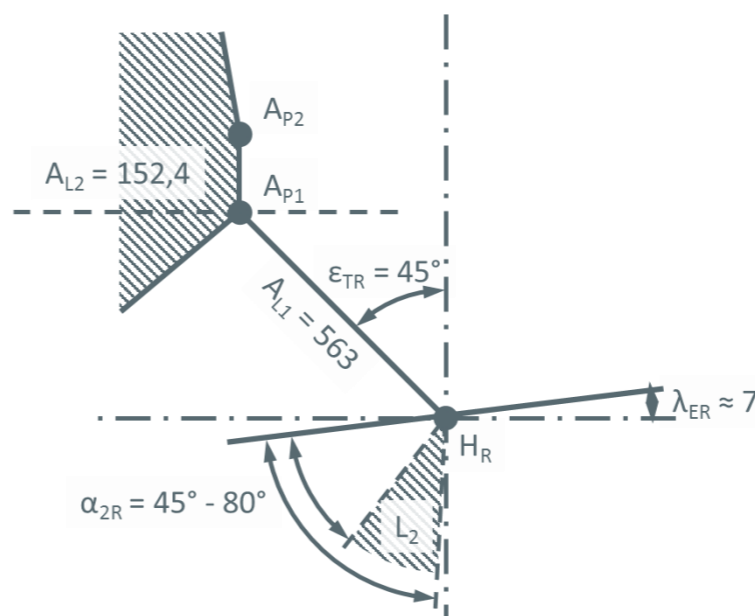

Buckle Side

## Configuration No. 3

Seat Cushion	15°
Backrest	45°
Opening Angle	120°

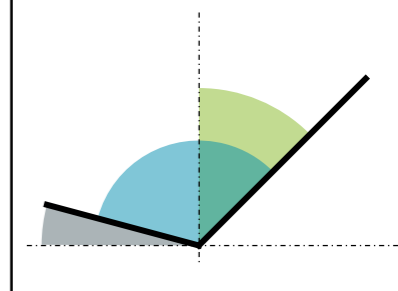

# Extended Use Position (15° // 45°)

- As the upper body of the H-Point manikin is reclined against the backrest, the H-point is pushed forward and upwards by approximately 10 mm.

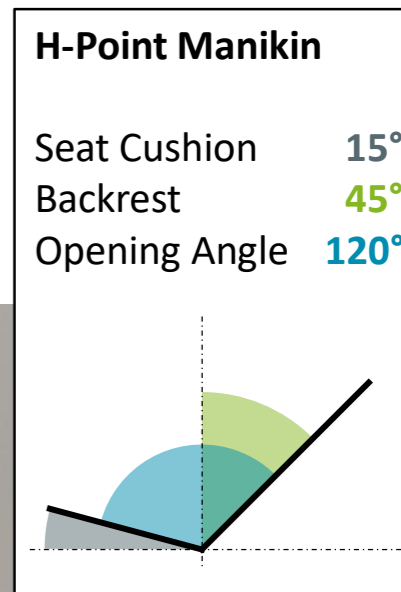
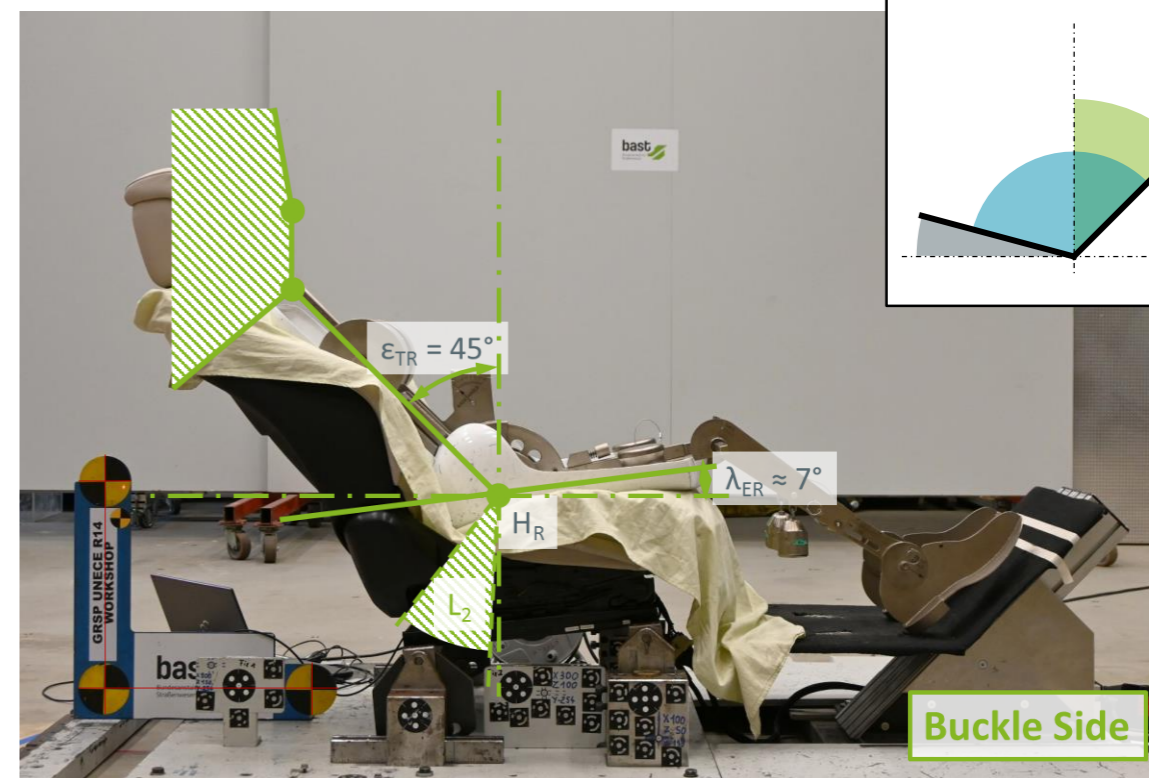
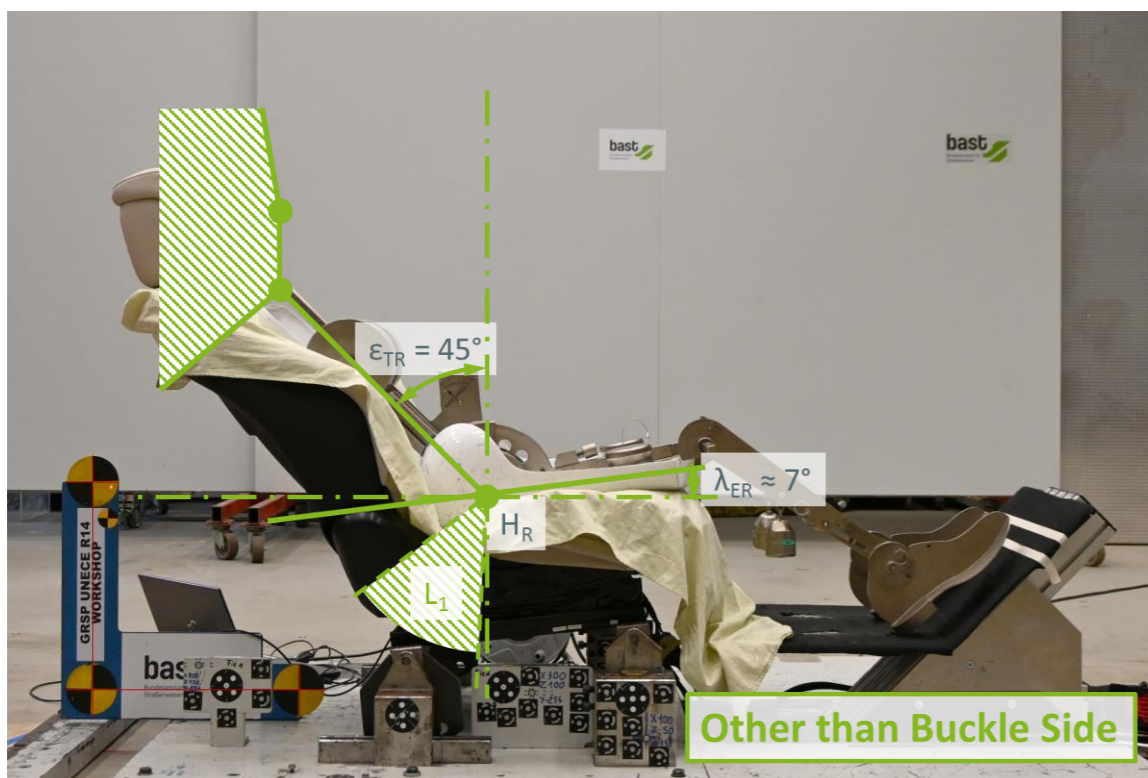

# Extended Use Position (15° // 45°)

- ▶ No continuous contact between the dummy's back and seatback

## Hybrid III 5<sup>th</sup> Female

Seat Cushion 15°  
Backrest 45°  
Opening Angle 120°

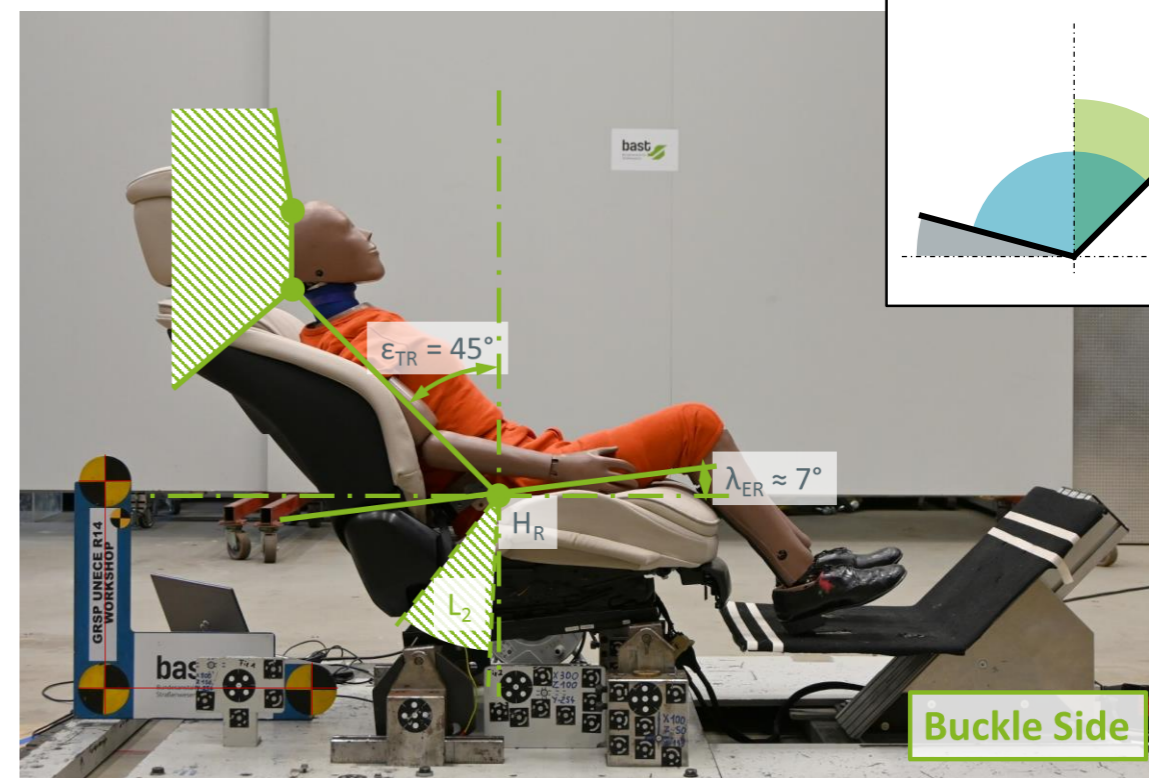
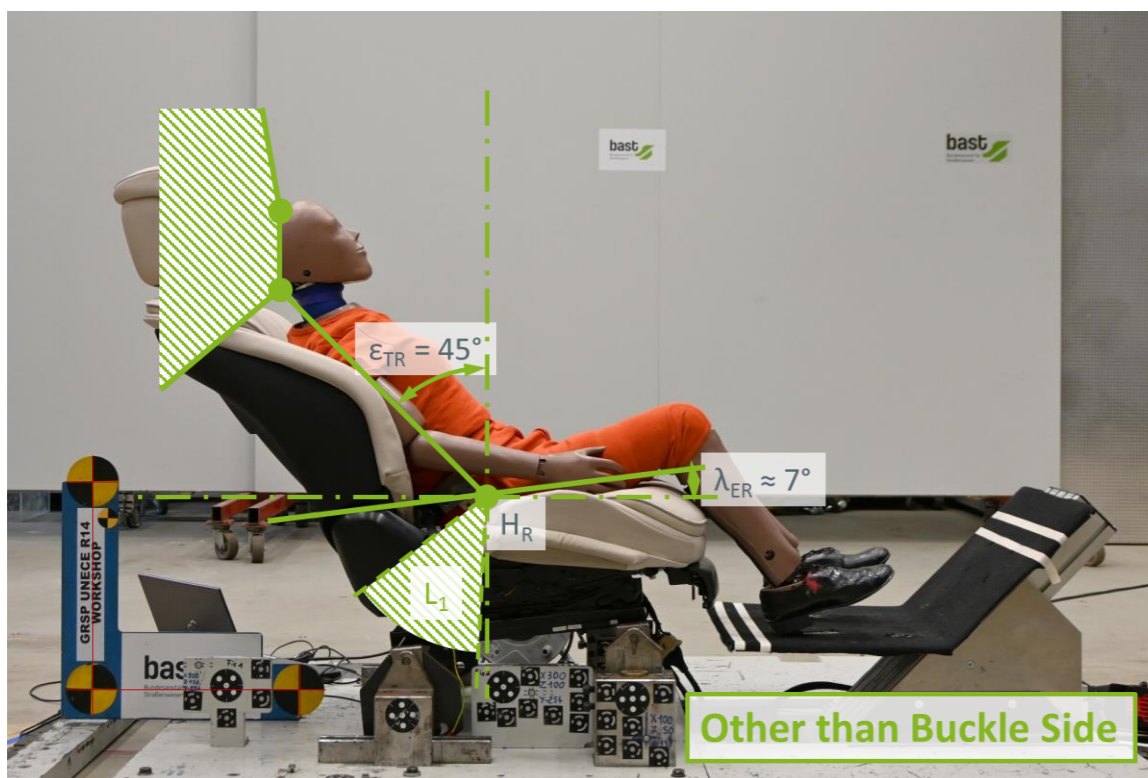
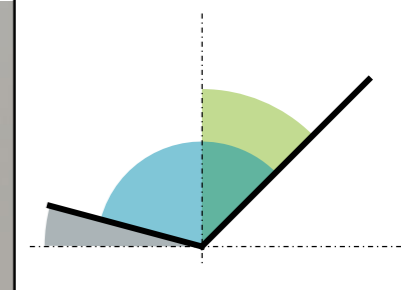



# Extended Use Position (15° // 45°)

- ▶ No continuous contact between the dummy's back and seatback

## Hybrid III 50<sup>th</sup> Male

Seat Cushion	15°
Backrest	45°
Opening Angle	120°

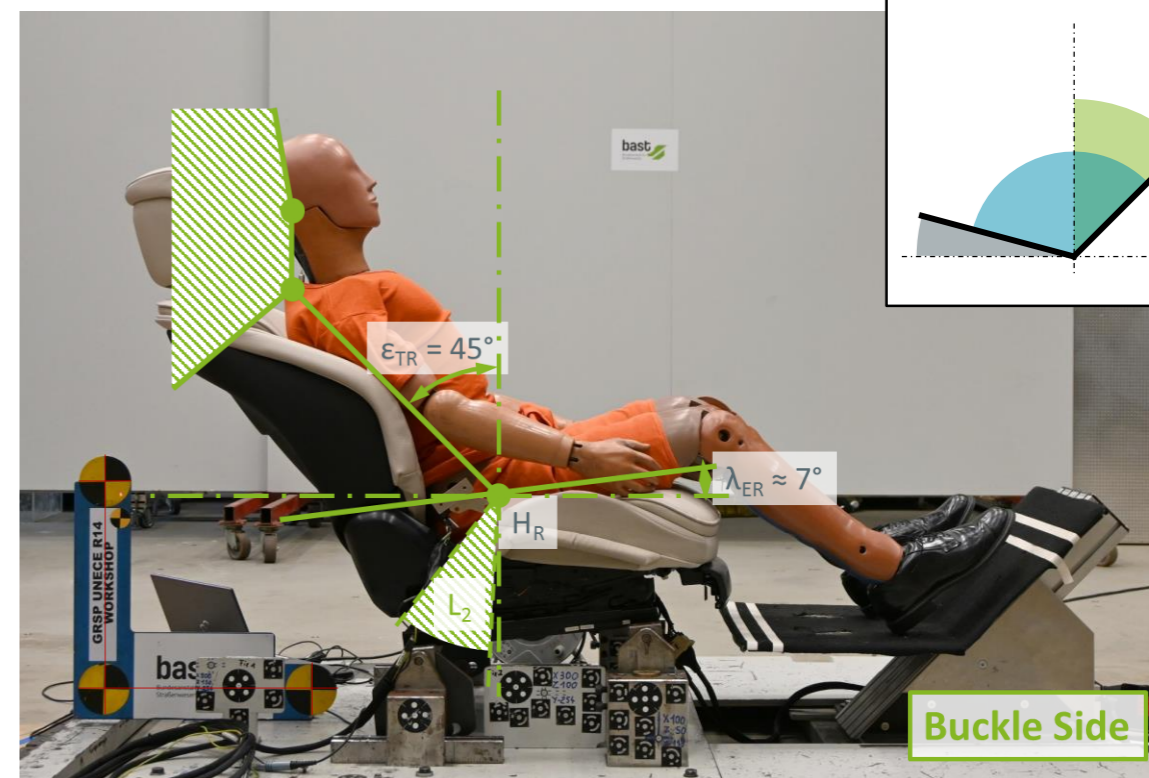
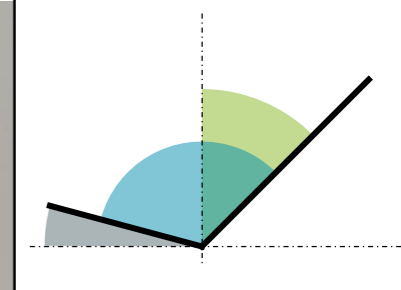

# Extended Use Position (15° // 45°)

- ▶ No continuous contact between the dummy's back and seatback

## Hybrid III 95<sup>th</sup> Male

Seat Cushion	15°
Backrest	45°
Opening Angle	120°

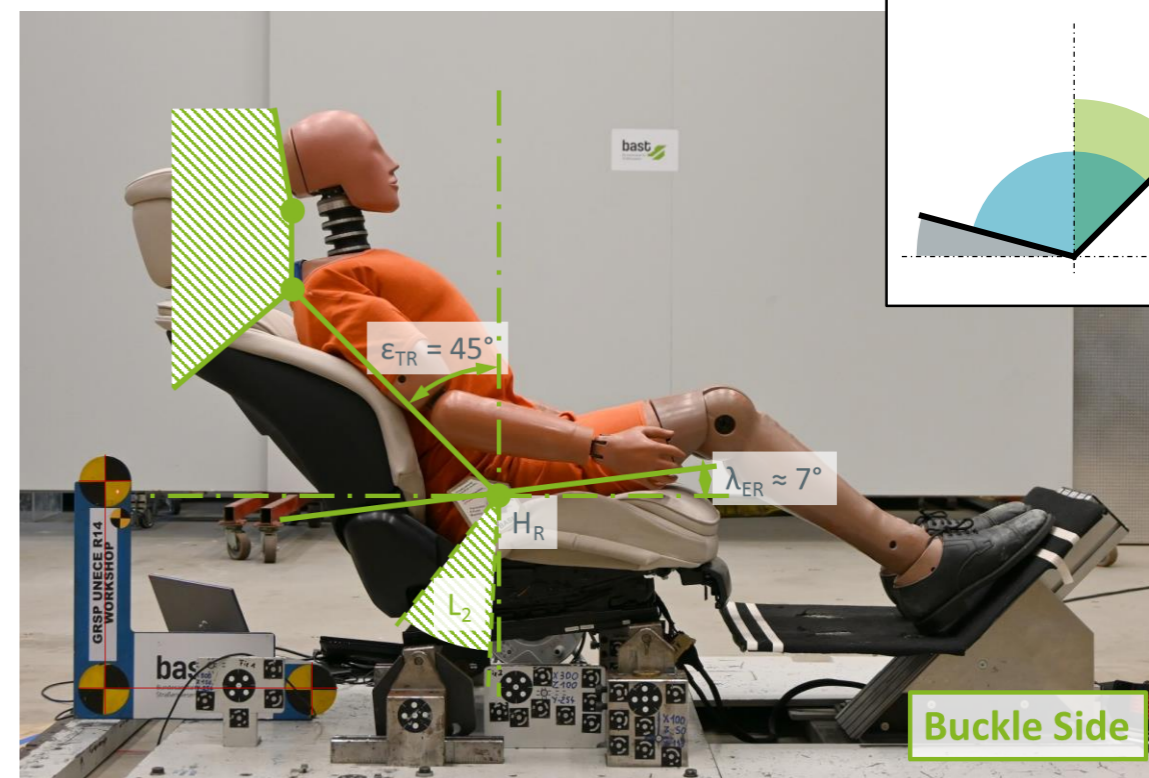
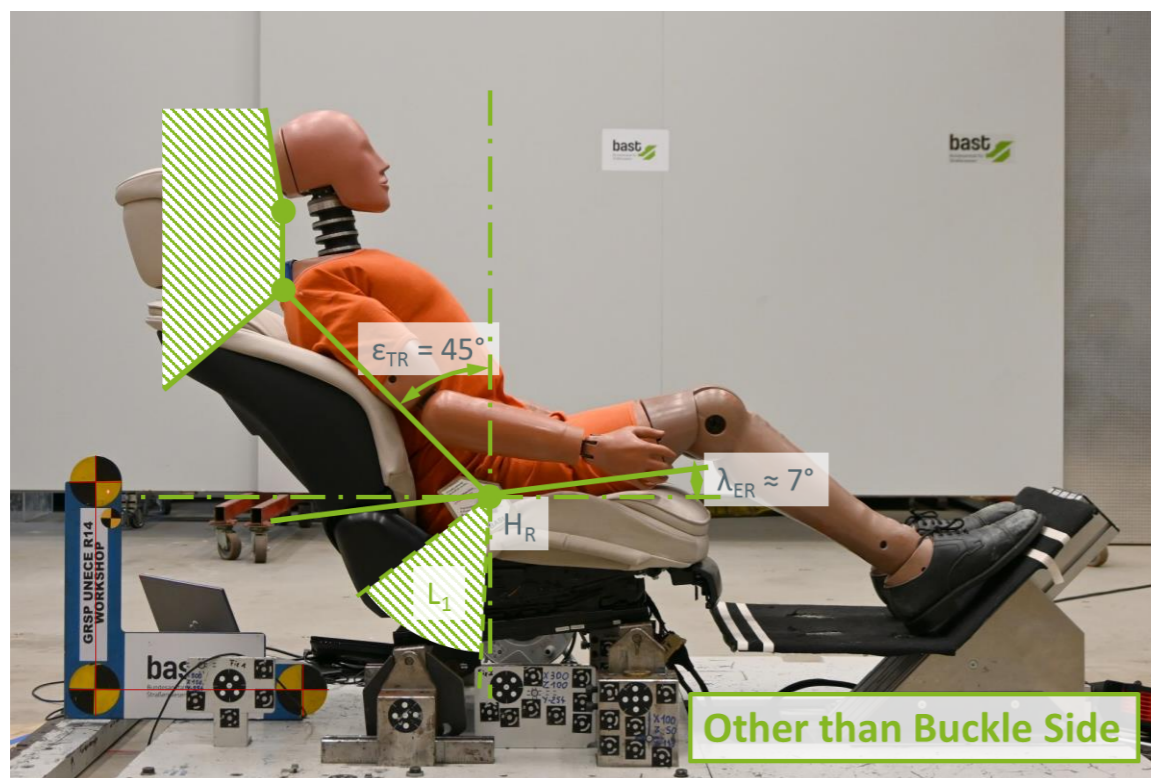
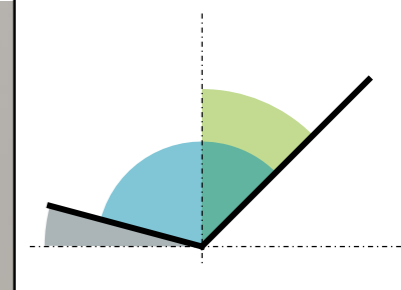

# Extended Use Position (15° // 45°)

- ▶ Continuous contact between the dummy's back and seatback
- ▶ Contact between pelvis and thigh flesh

## THOR-50M

Seat Cushion 15°  
Backrest 45°  
Opening Angle 120°

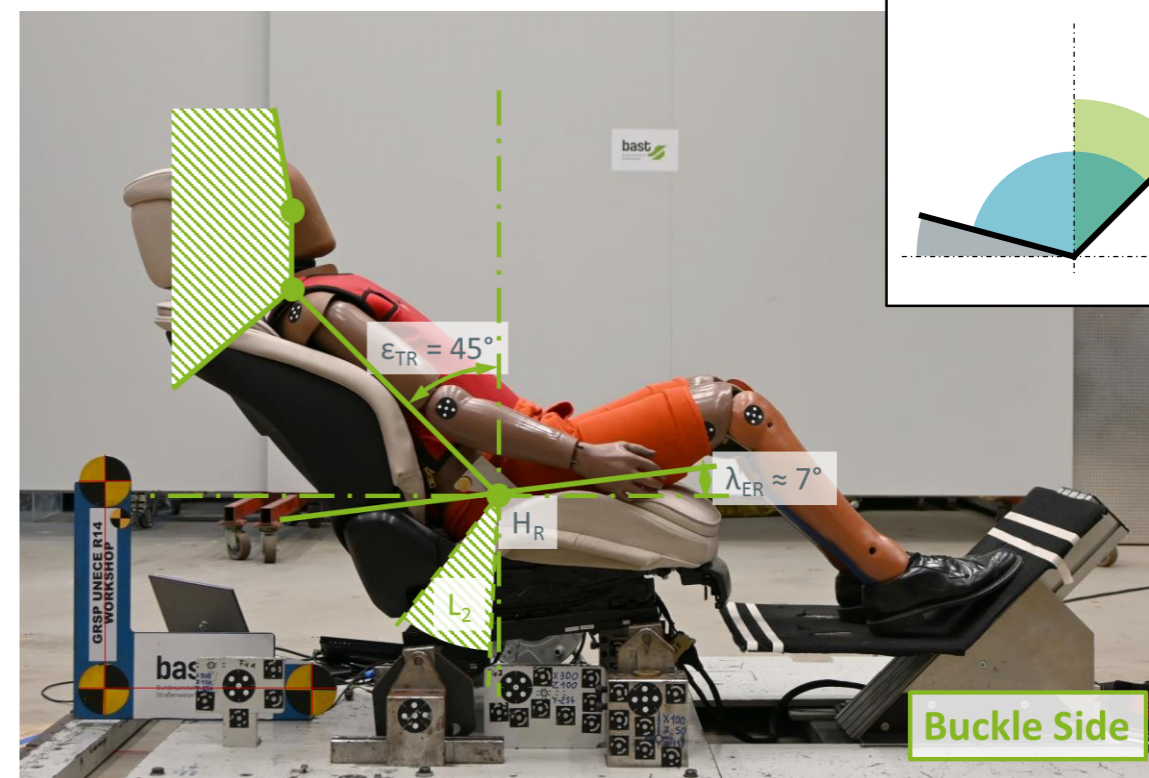
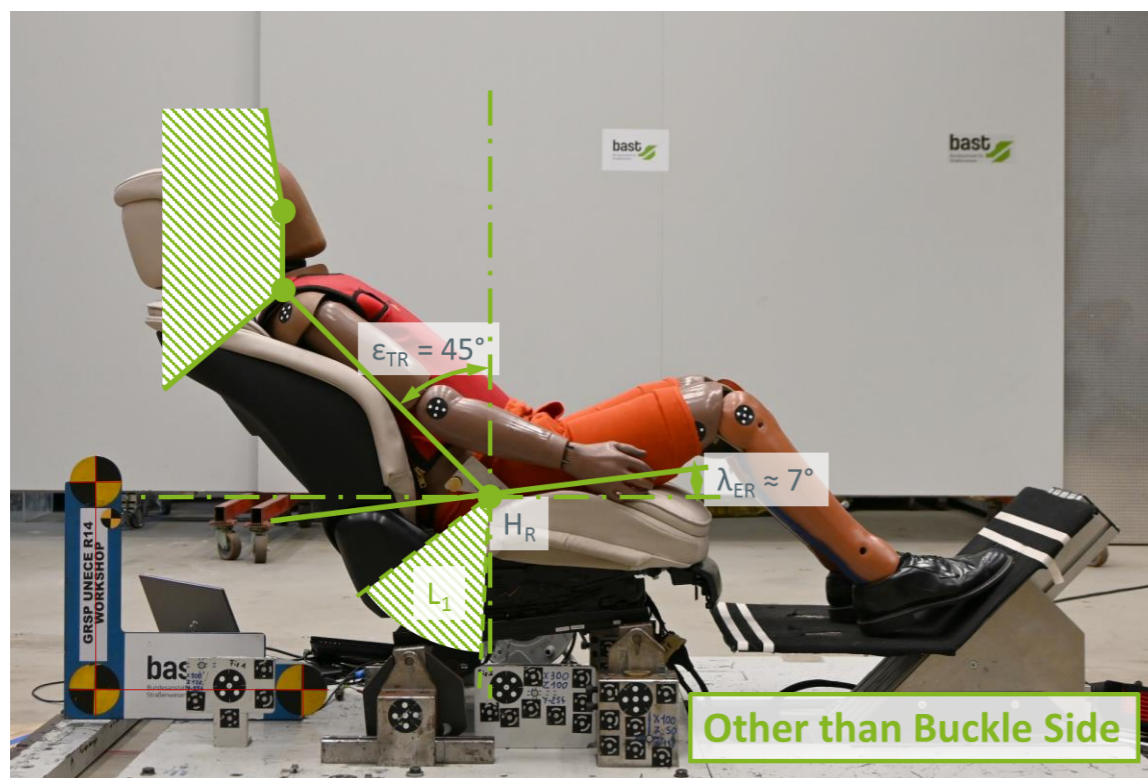
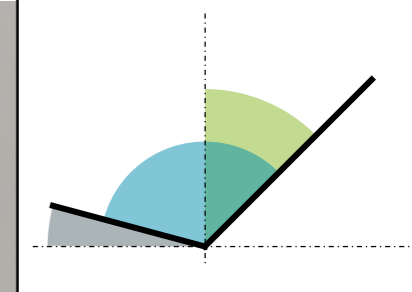

# Extended Use Position (15° // 45°)

- ▶ Continuous contact between the dummy's back and seatback
- ▶ No contact between pelvic and thigh flesh

## THOR-RS-50M

Seat Cushion 15°  
Backrest 45°  
Opening Angle 120°

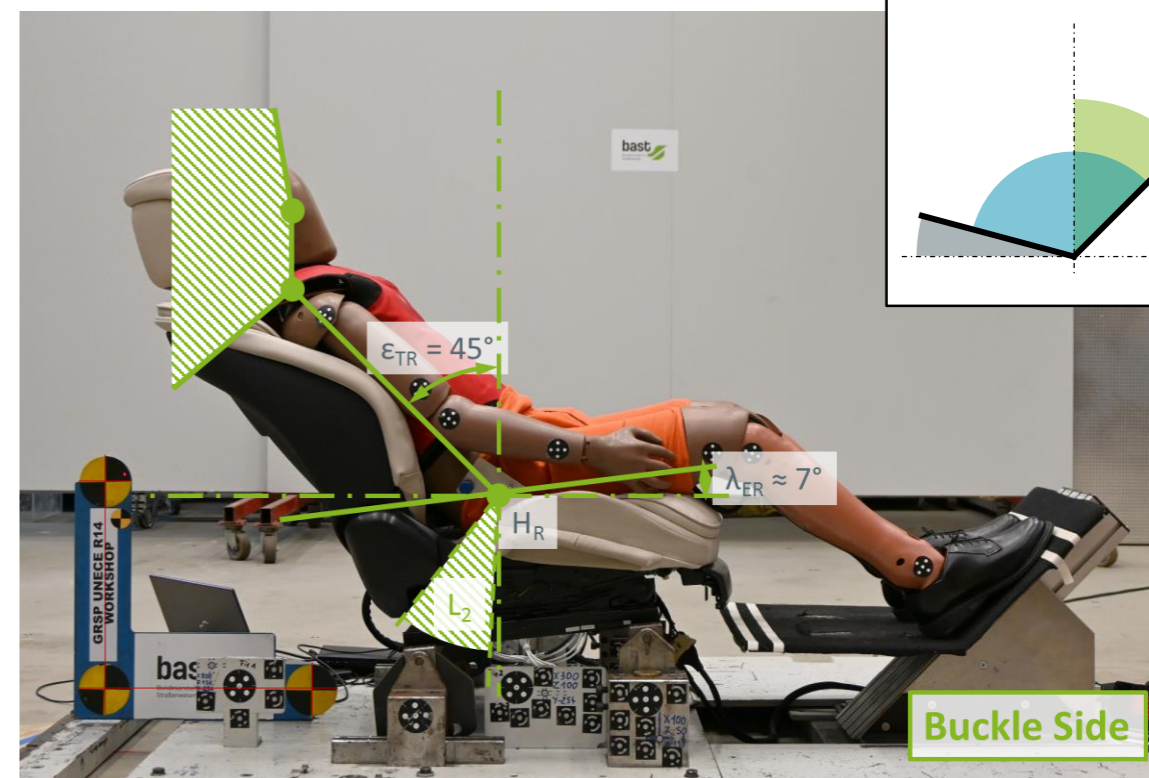
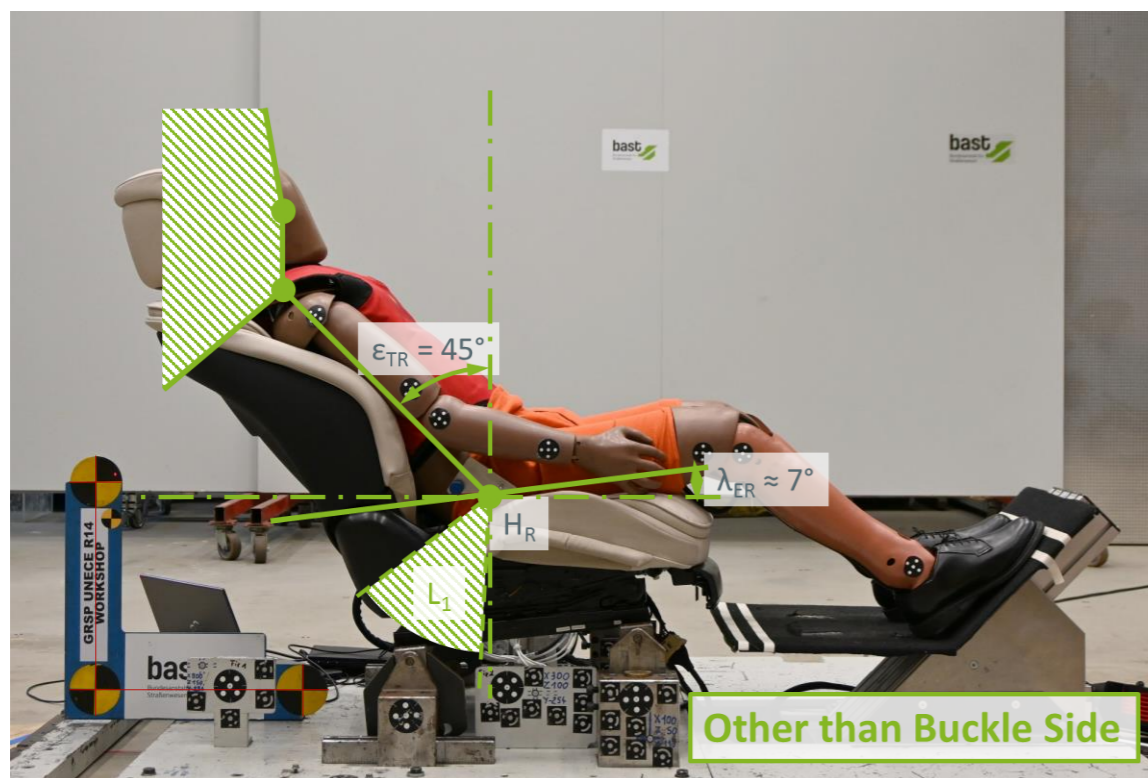
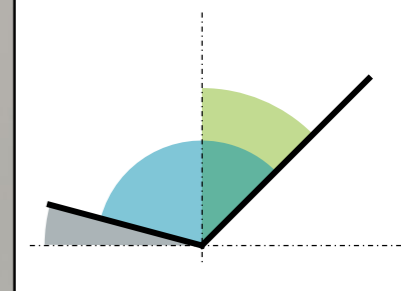

# Extended Use Position (15° // 45°)

**Male Participant**  
 Height: 172 cm  
 Seat Cushion 15°  
 Backrest 45°  
 Opening Angle 120°

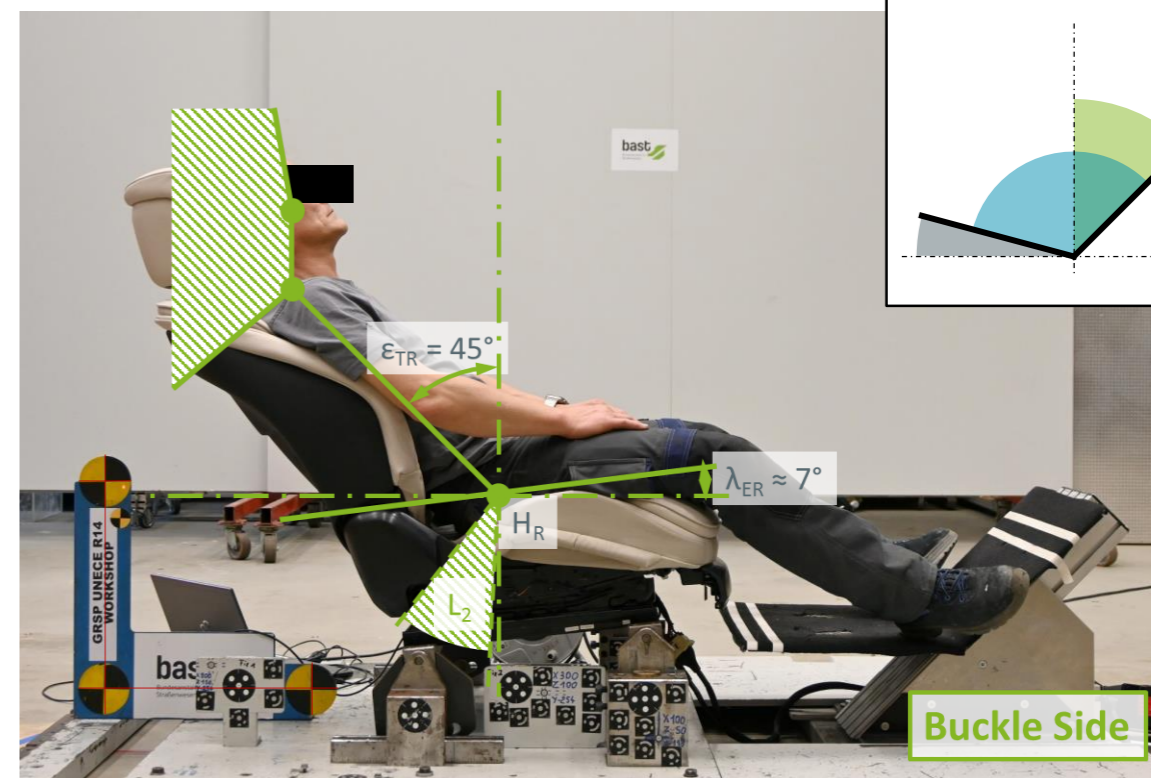
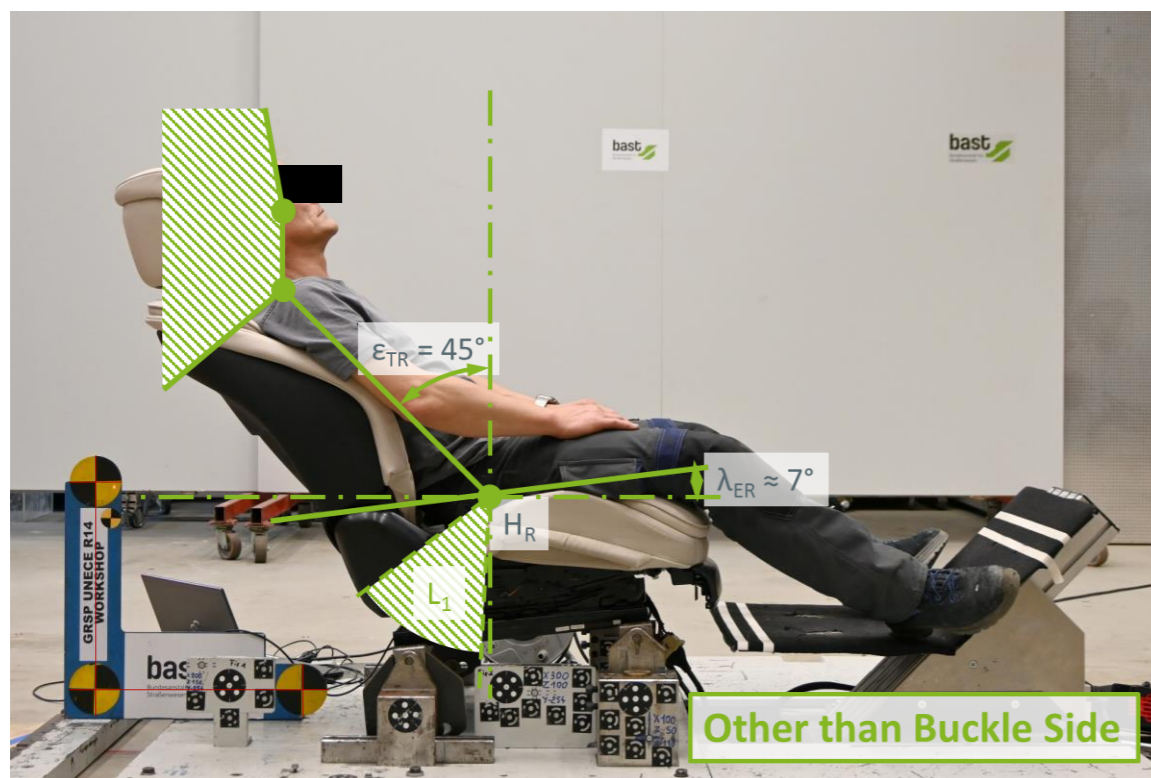
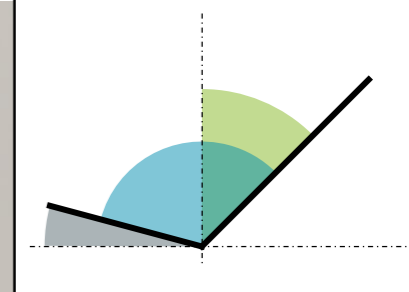

# Extended Use Position (15° // 45°)

**Male Participant**  
Height: 193 cm  
Seat Cushion 15°  
Backrest 45°  
Opening Angle 120°

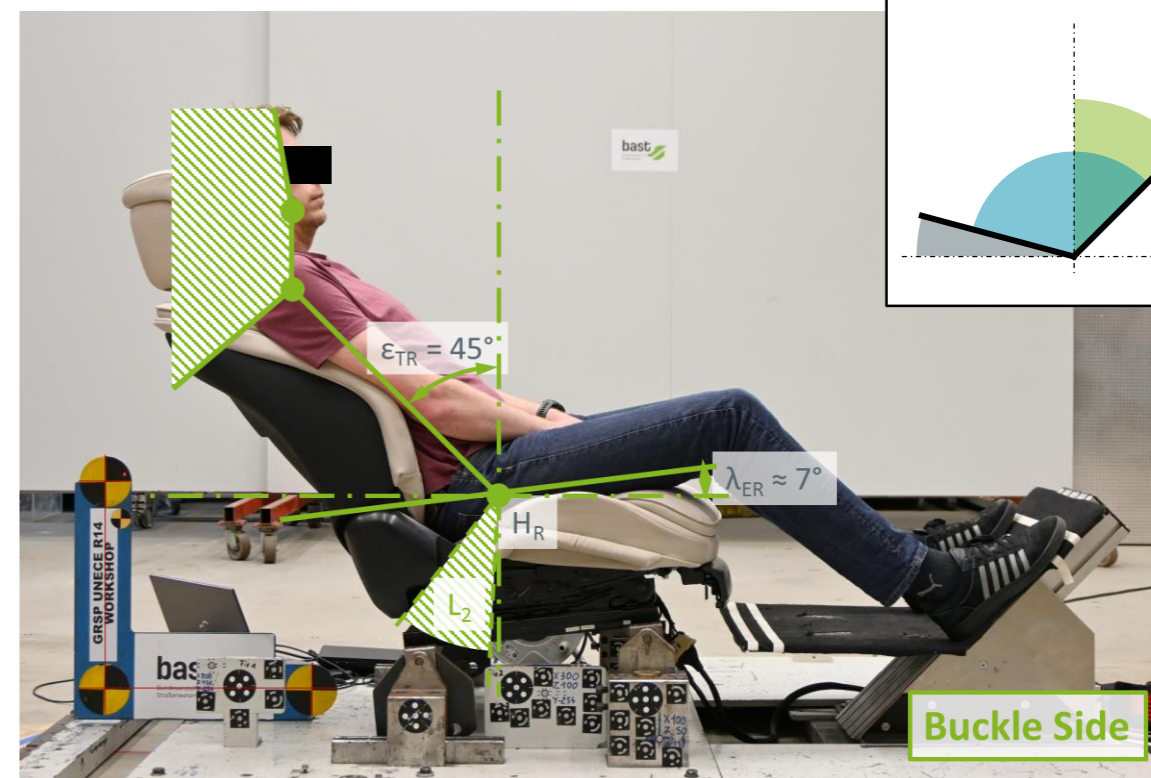
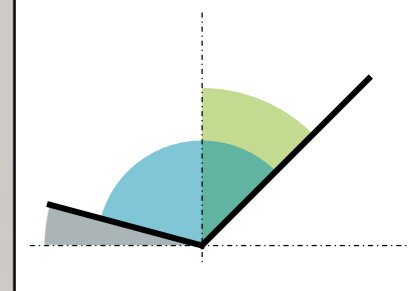

# Extended Use Position (15° // 45°)

**Female Participant**  
 Height: unknown  
 Seat Cushion 15°  
 Backrest 45°  
 Opening Angle 120°

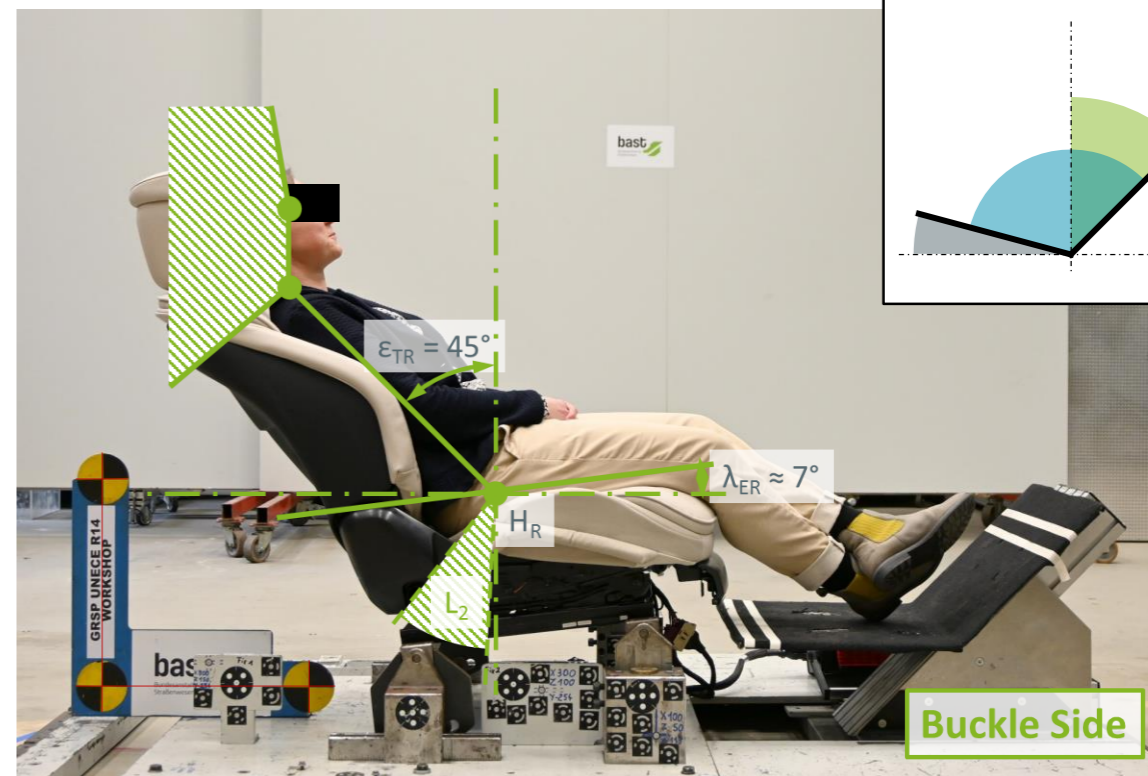
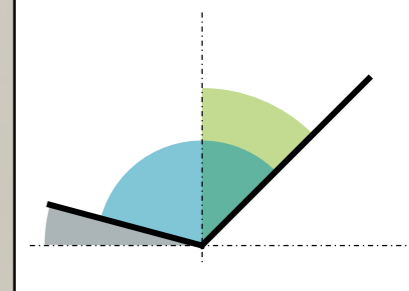

# Extended Use Position (15° // 45°)

**Male Participant**  
Height: unknown  
Seat Cushion 15°  
Backrest 45°  
Opening Angle 120°

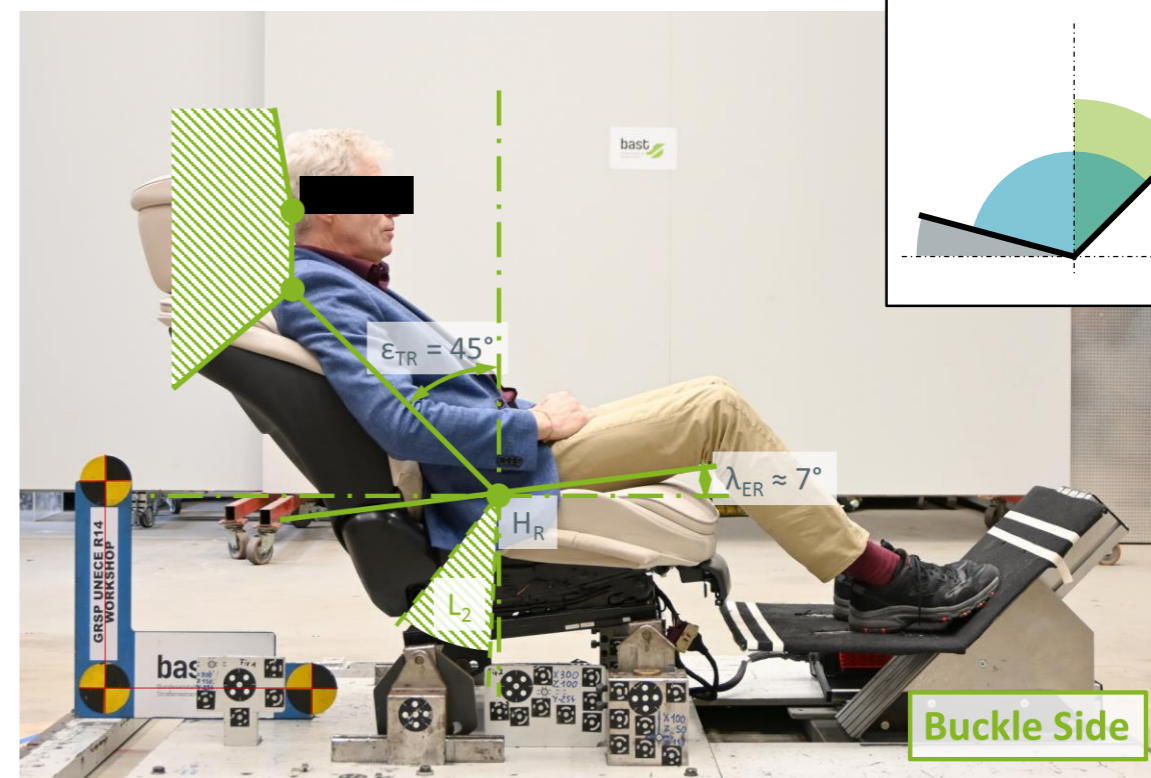
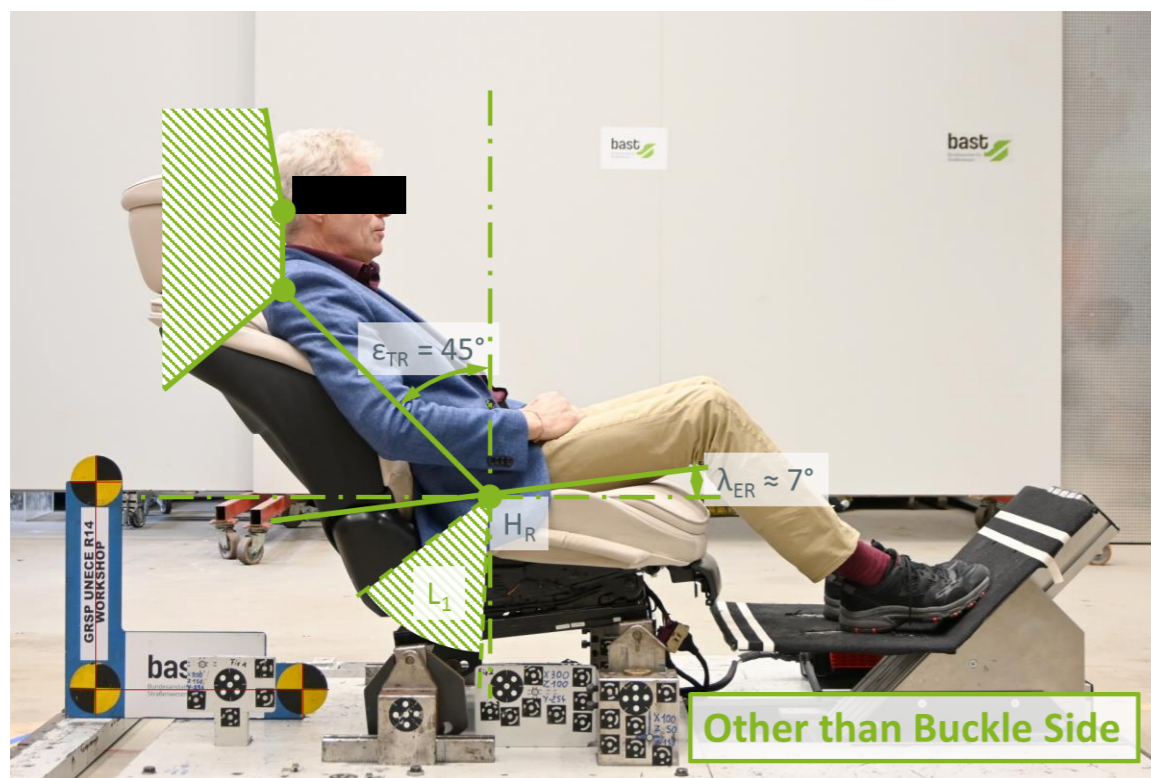
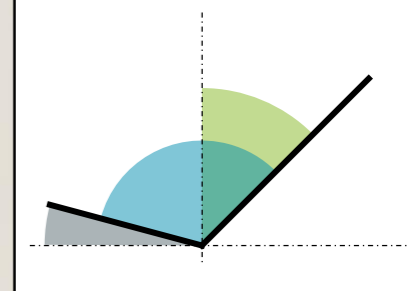



# Extended Use Position (15° // 45°)

**Male Participant**  
Height: unknown  
Seat Cushion 15°  
Backrest 45°  
Opening Angle 120°

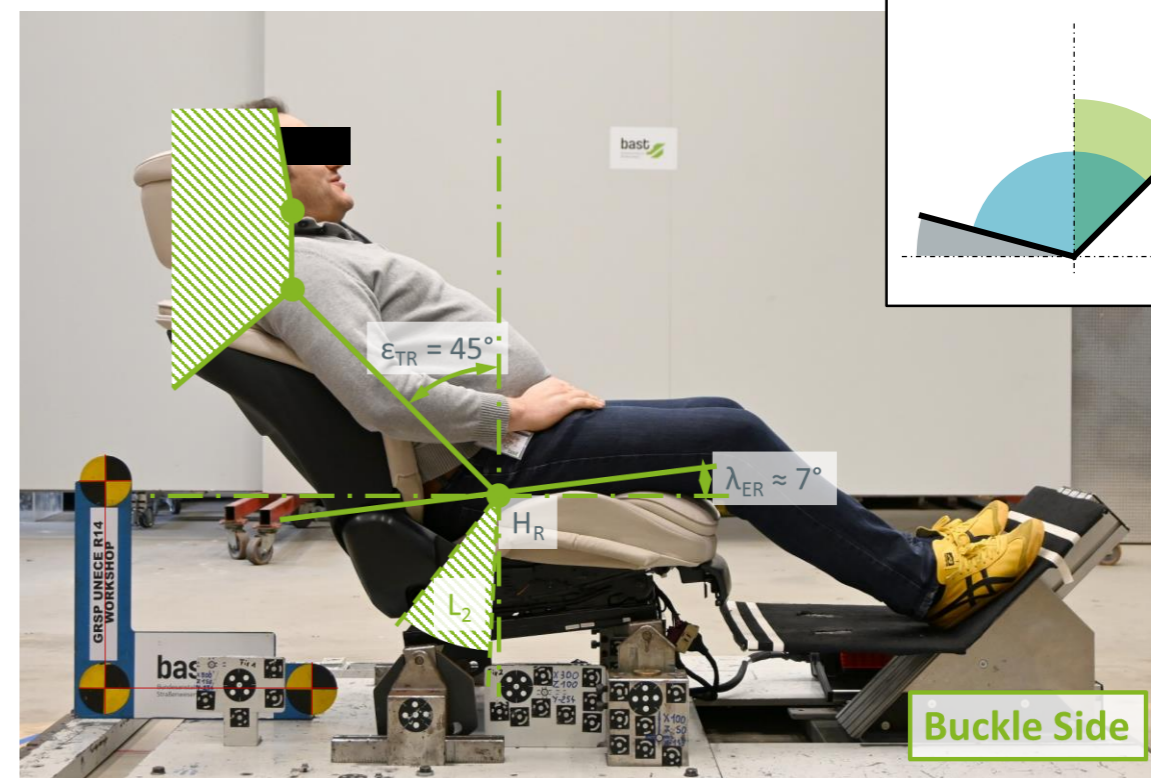
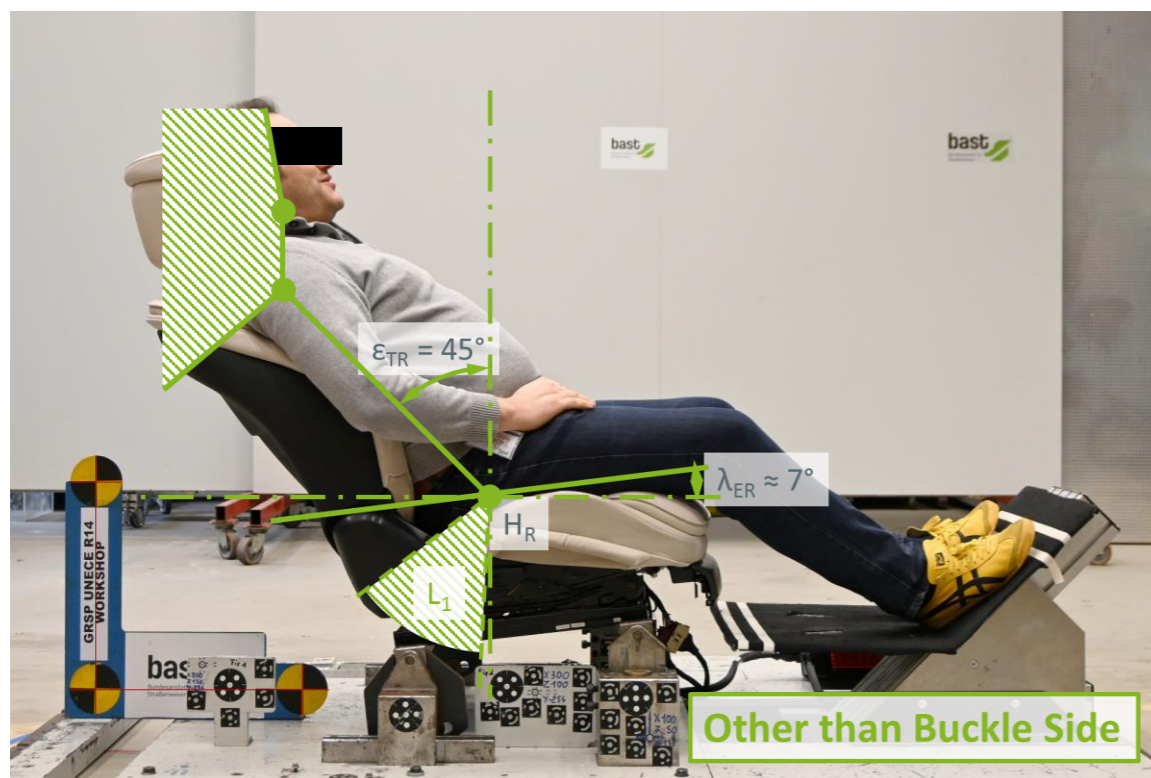
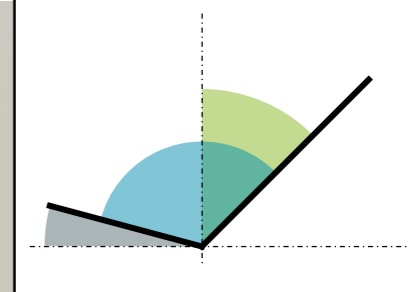

# Extended Use Position (25° // 35°)

- ▶ Seat cushion and backrest inclination are changed by 10° from the normal use position, while the opening angle remains unchanged from the normal use position
  - ▶ The  $E_R$ -Plane is tilted by the change in inclination of the seat cushion ( $\lambda_{ER} = 10^\circ$ )
  - ▶ The  $T_R$ -Plane is equivalent to the backrest angle ( $\epsilon_{TR} = 35^\circ$ )

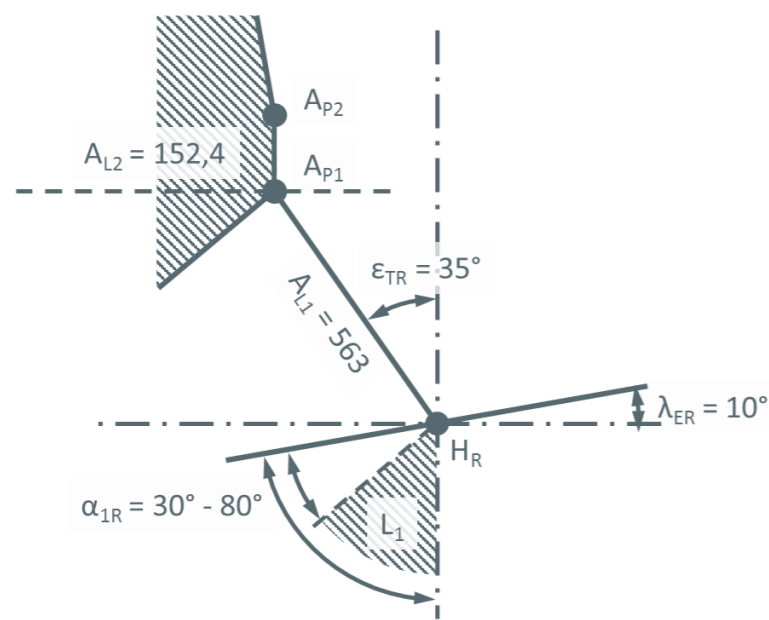

Other than Buckle Side

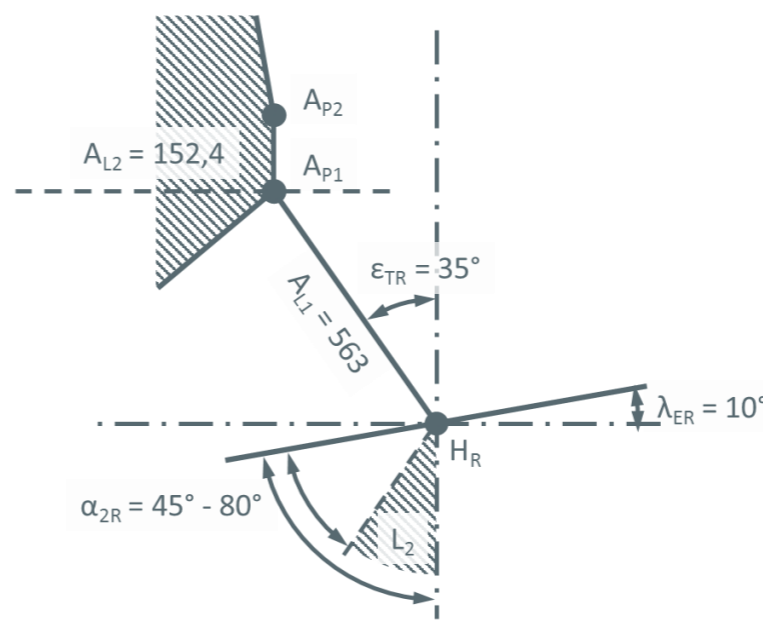

Buckle Side

## Configuration No. 4

Seat Cushion 25°  
Backrest 35°  
Opening Angle 100°

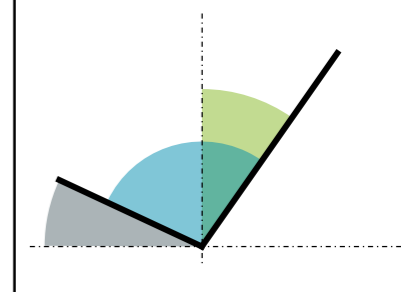

# Extended Use Position (25° // 35°)

## H-Point Manikin

Seat Cushion 25°  
Backrest 35°  
Opening Angle 100°

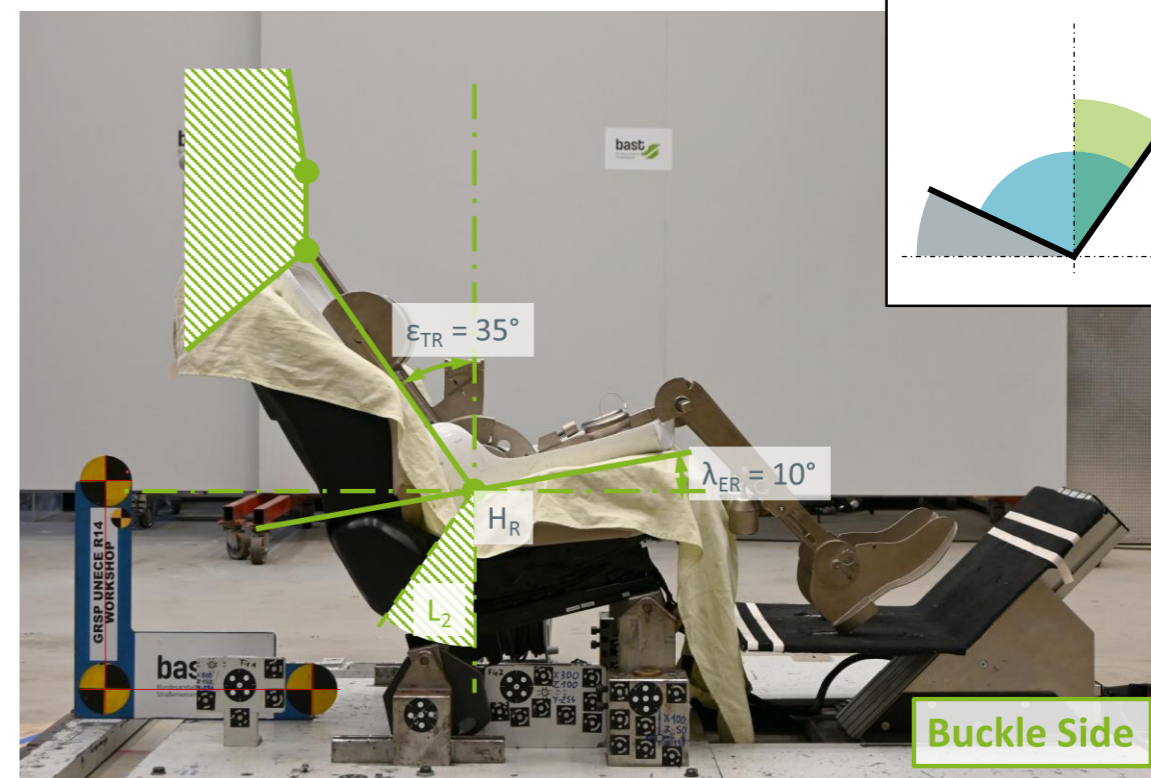
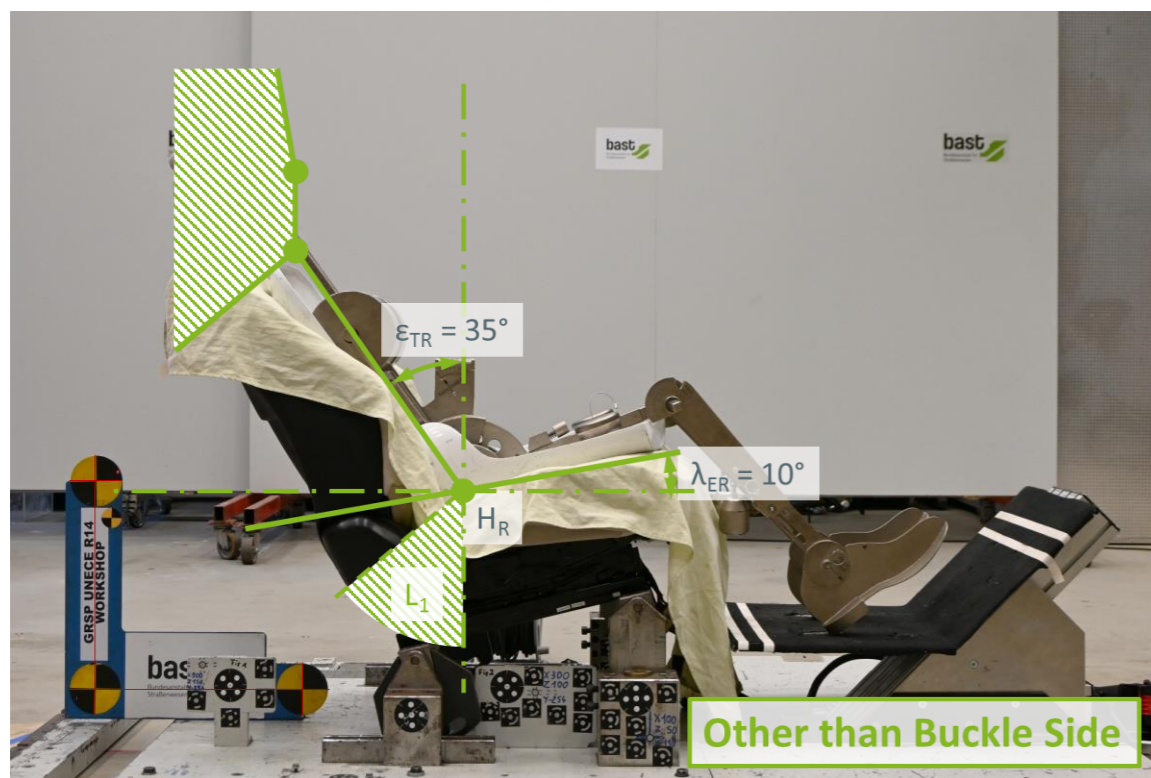
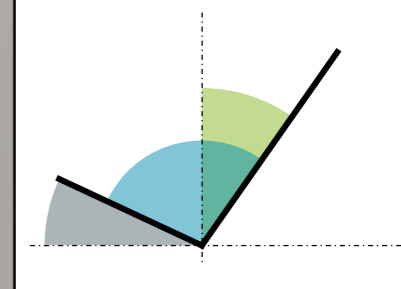

# Extended Use Position (25° // 35°)

## Hybrid III 5<sup>th</sup> Female

Seat Cushion 25°  
Backrest 35°  
Opening Angle 100°

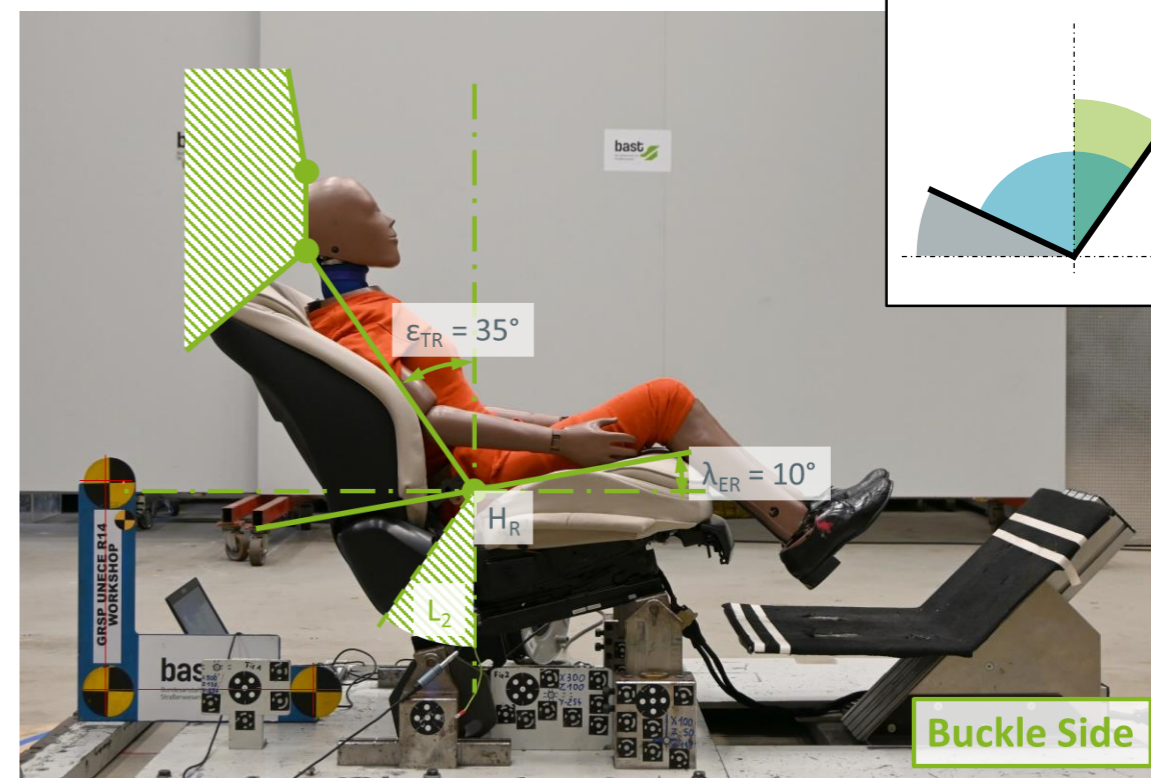
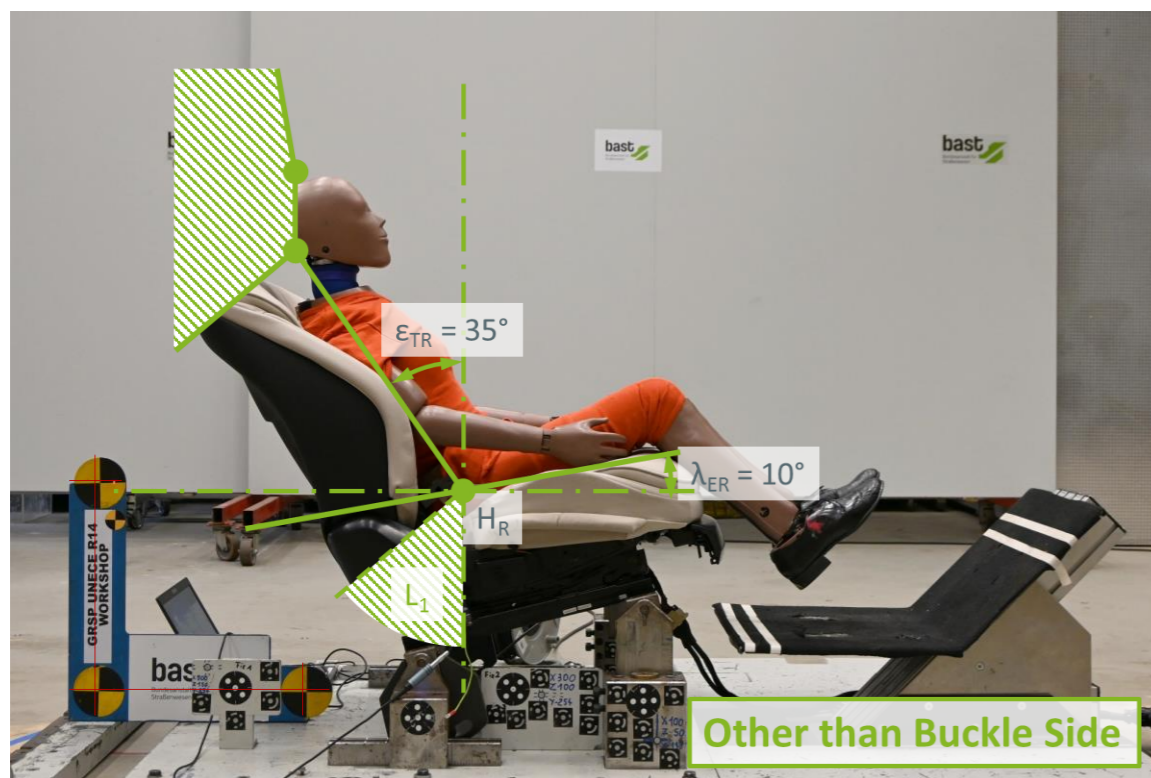
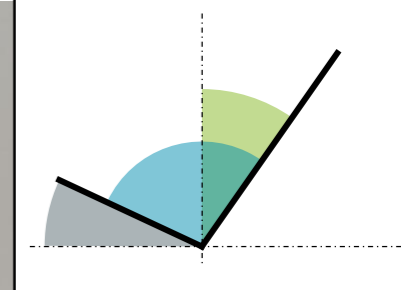



# Extended Use Position (25° // 35°)

## Hybrid III 95<sup>th</sup> Male

Seat Cushion 25°  
Backrest 35°  
Opening Angle 100°

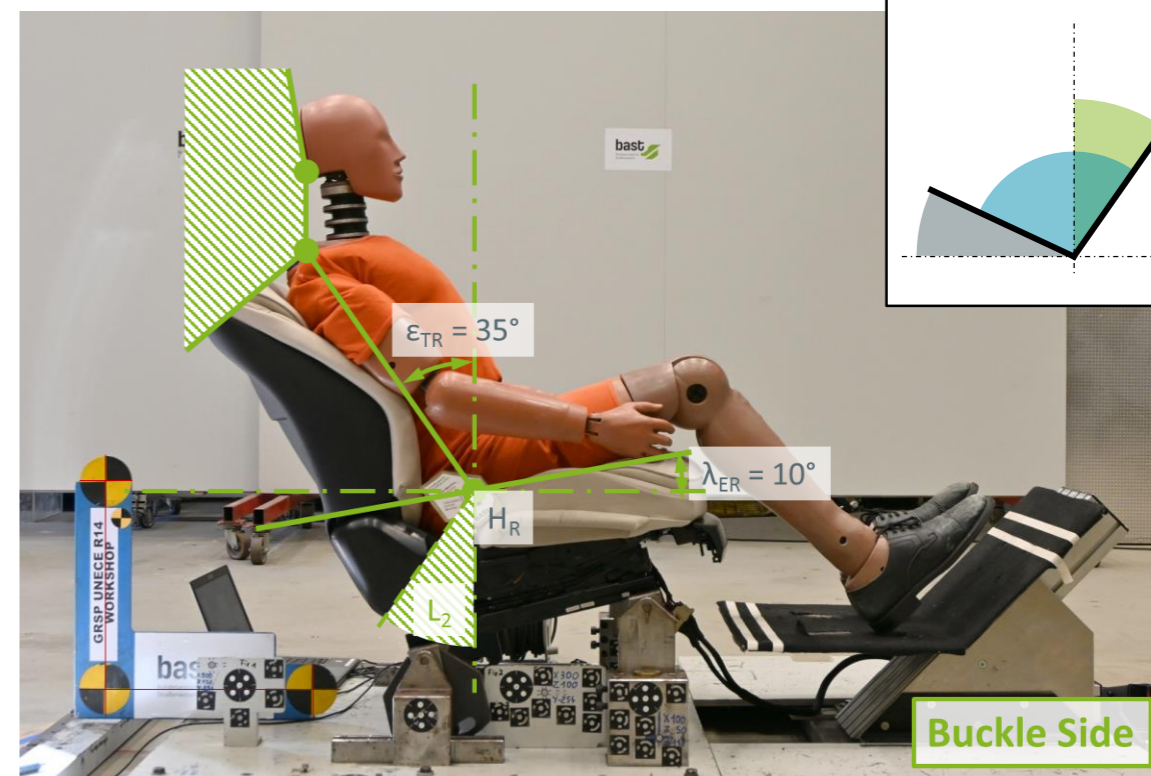
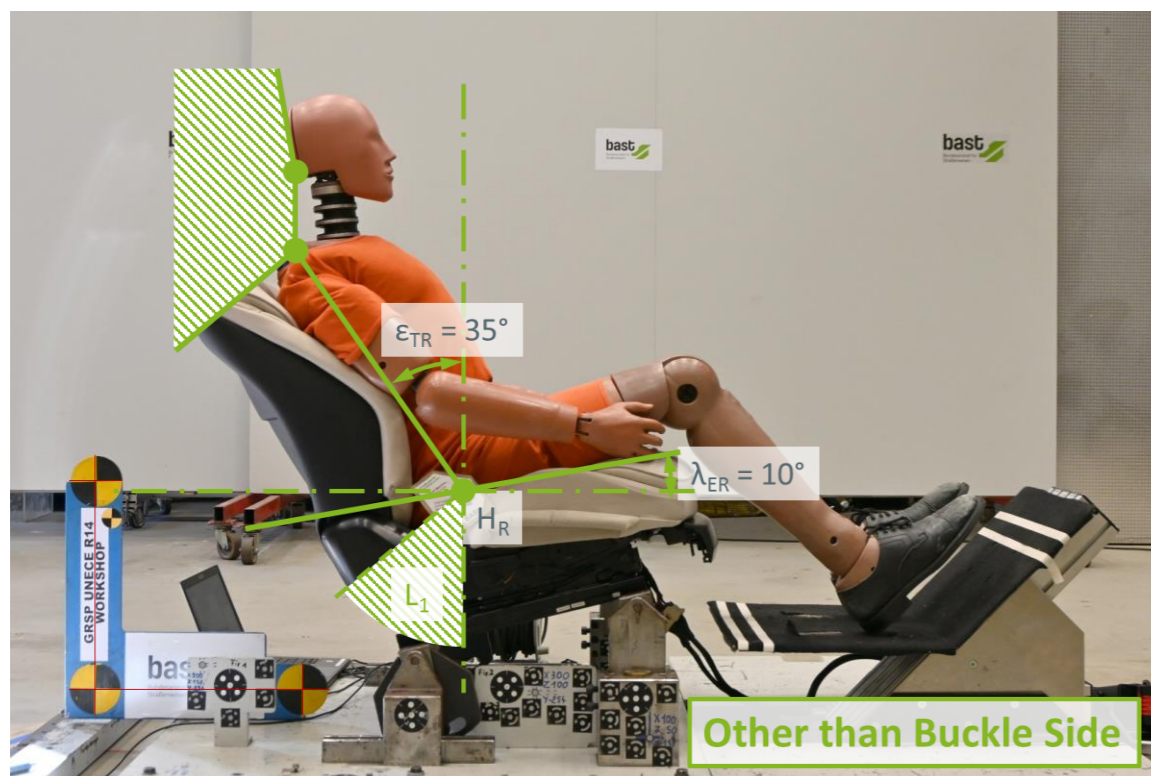
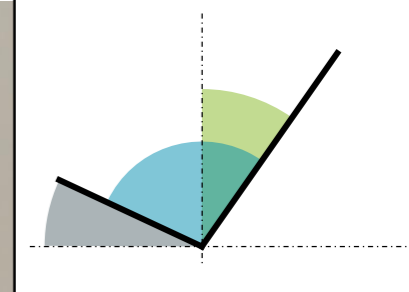

# Extended Use Position (25° // 35°)

## THOR-50M

Seat Cushion 25°  
Backrest 35°  
Opening Angle 100°

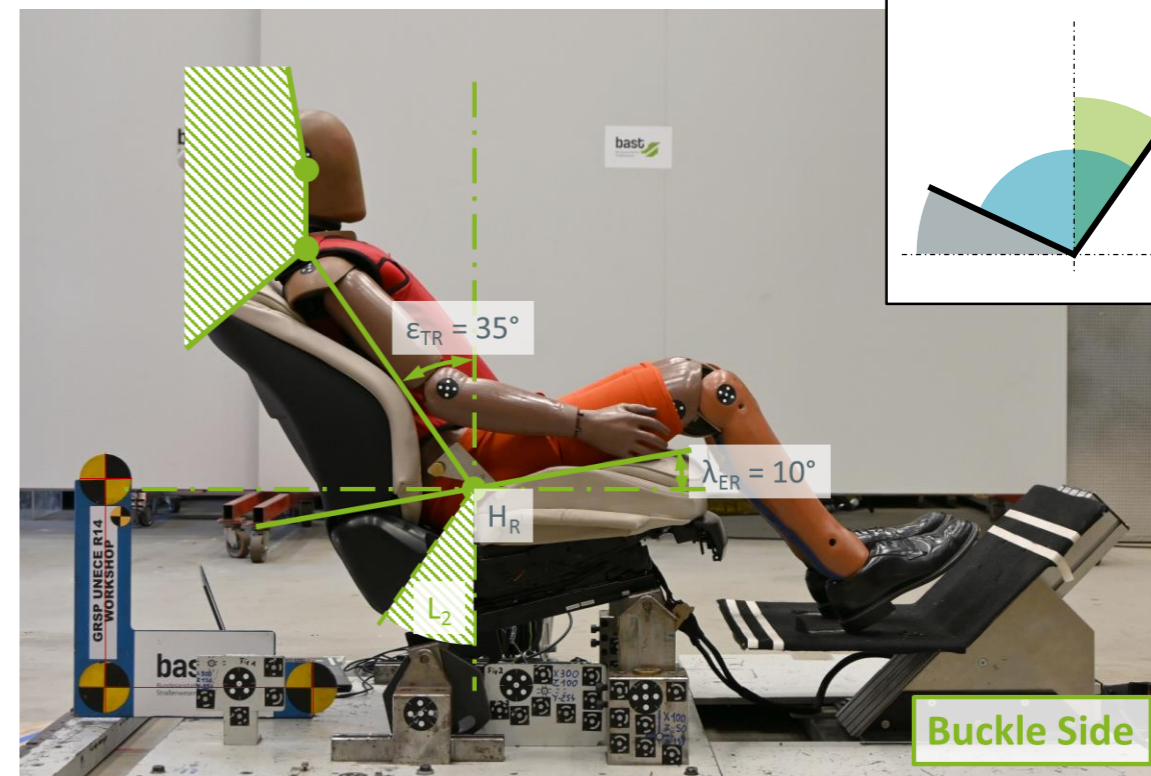
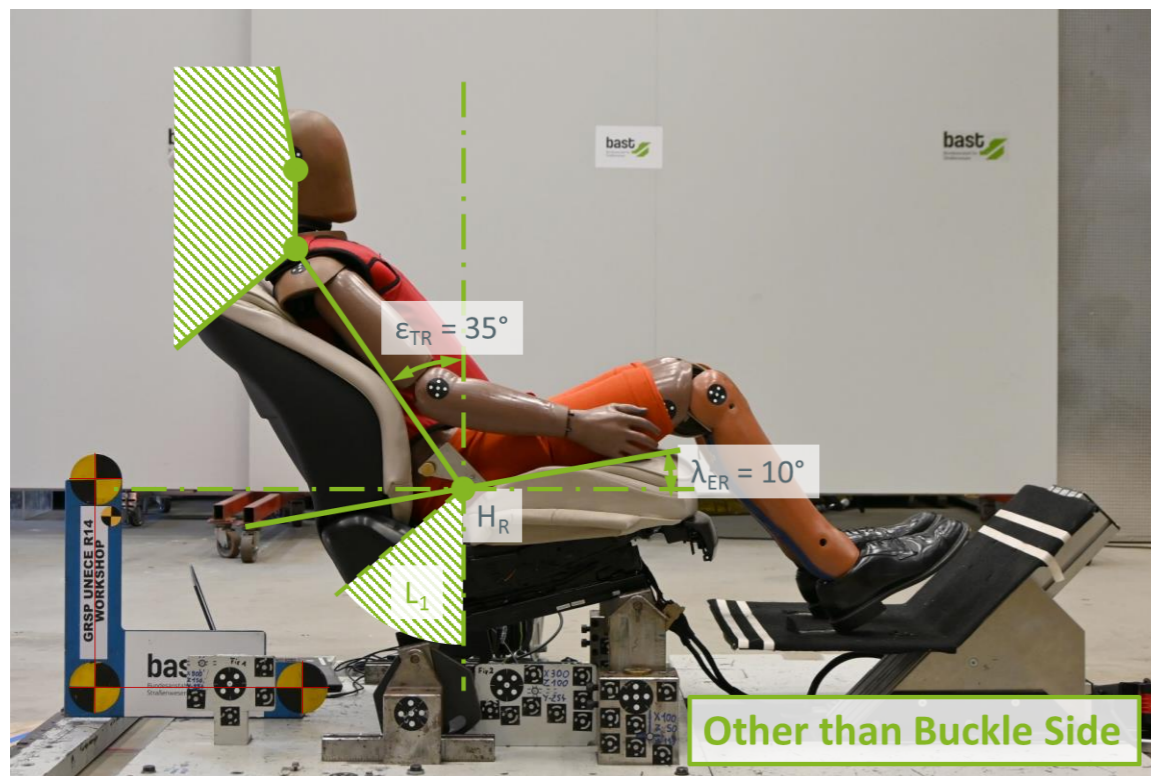
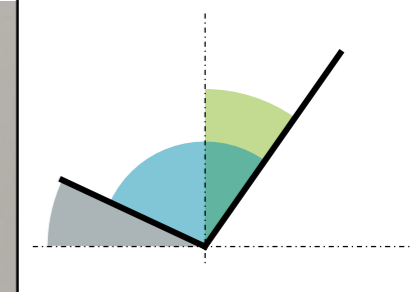

# Extended Use Position (25° // 35°)

## THOR-RS-50M

Seat Cushion 25°  
Backrest 35°  
Opening Angle 100°

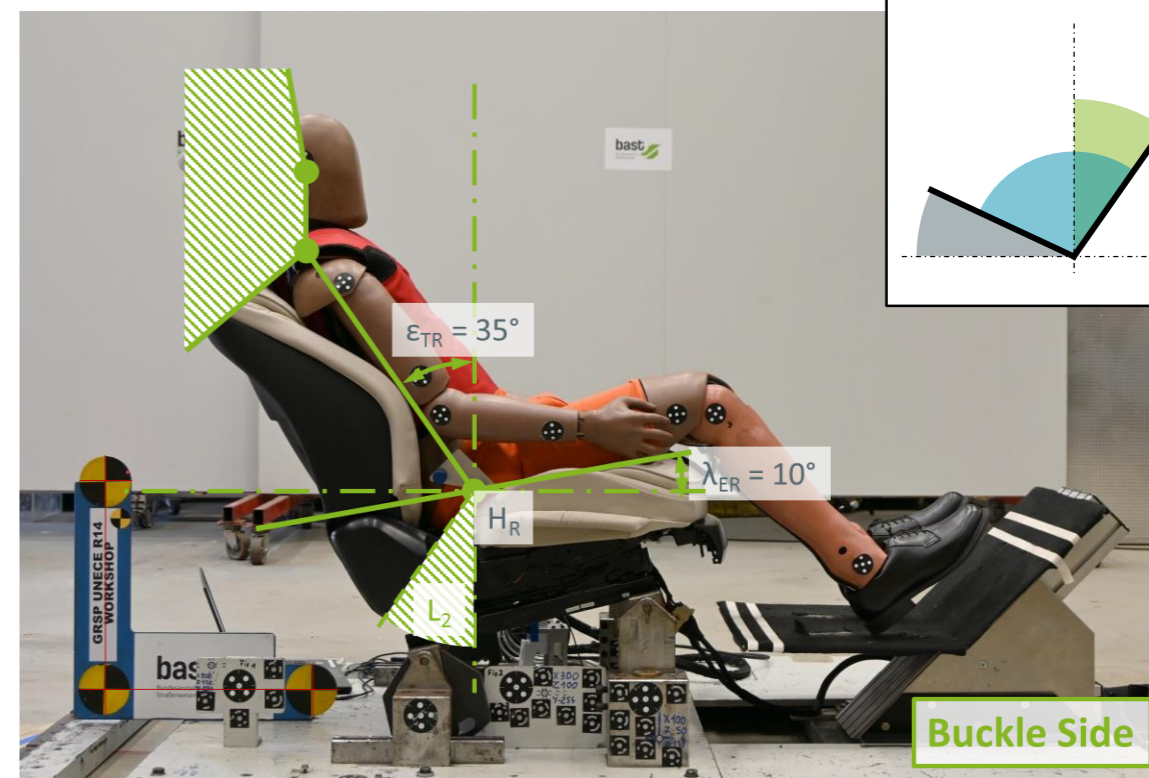
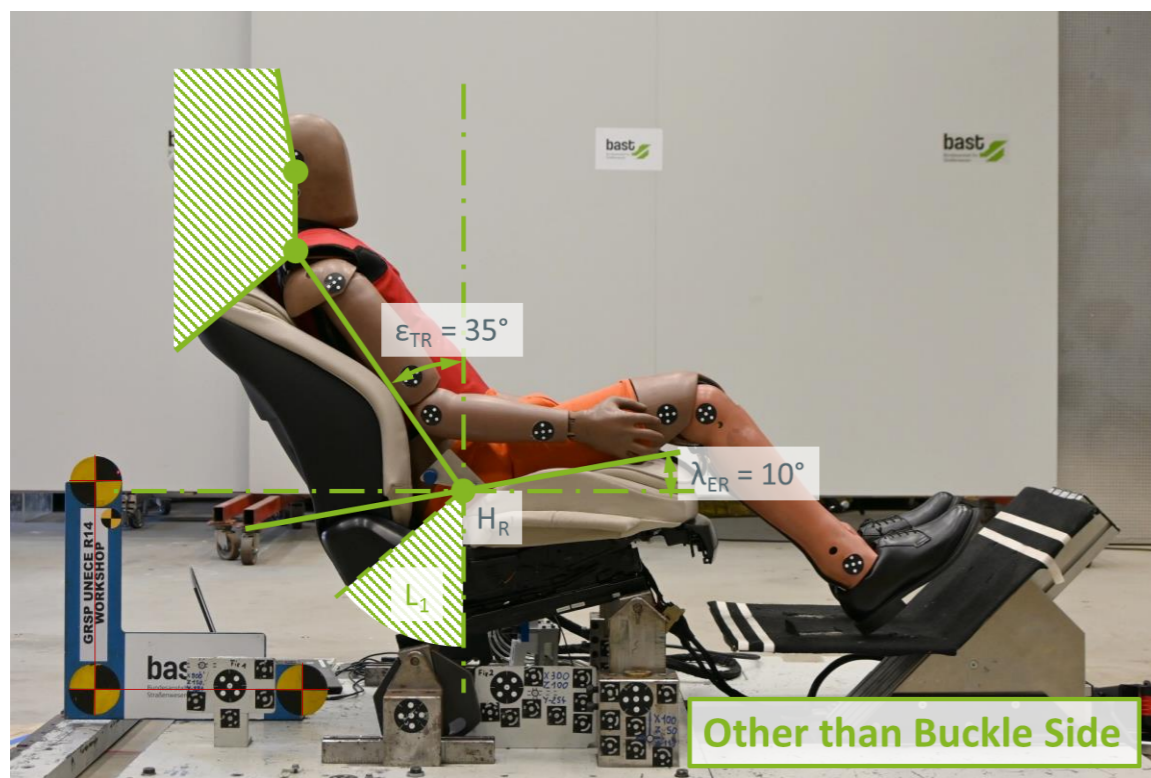
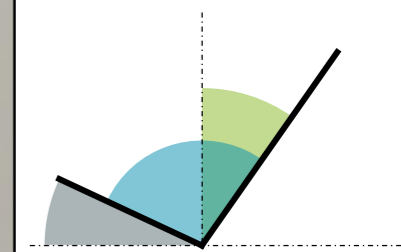



# Extended Use Position (25° // 35°)

**Male Participant**  
Height: 170 cm  
Seat Cushion 25°  
Backrest 35°  
Opening Angle 100°

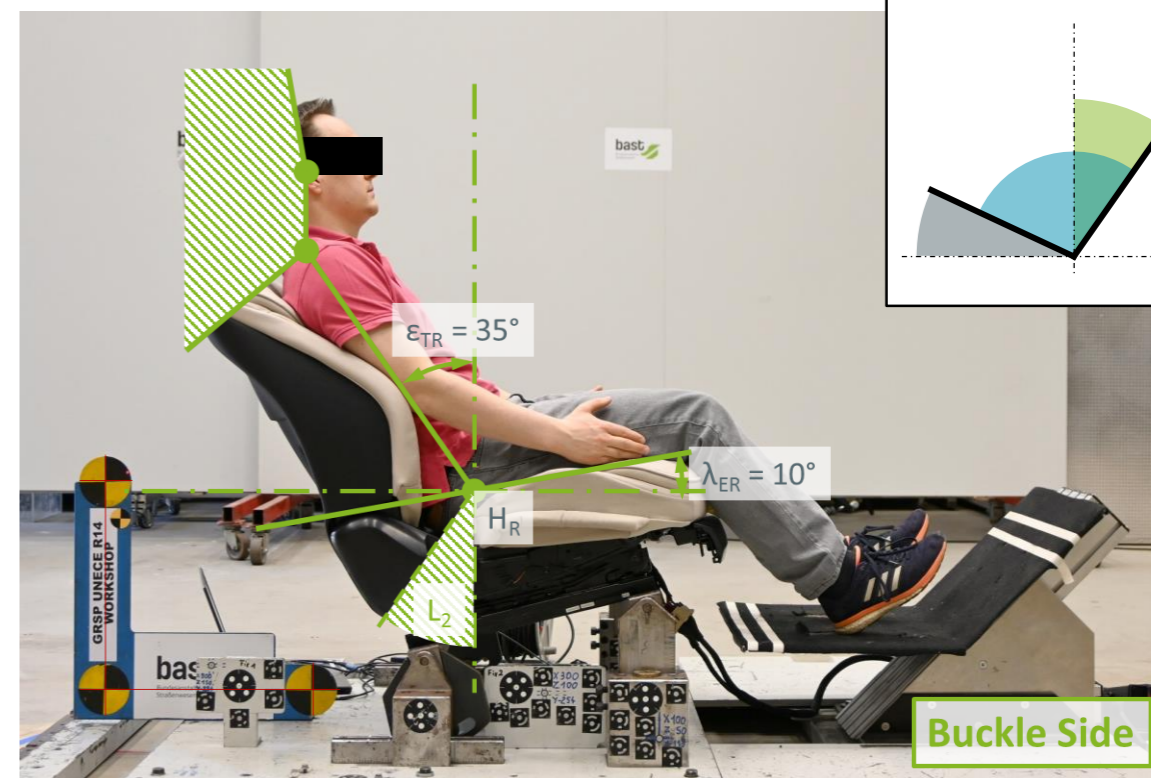
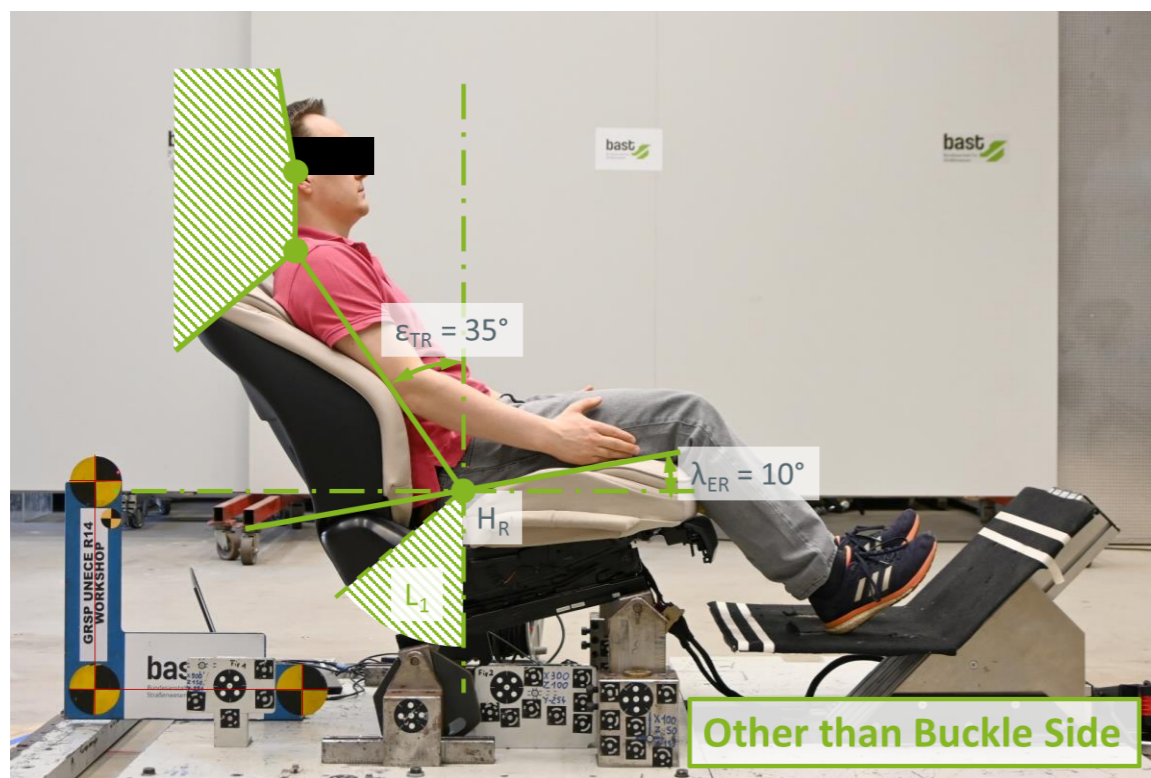
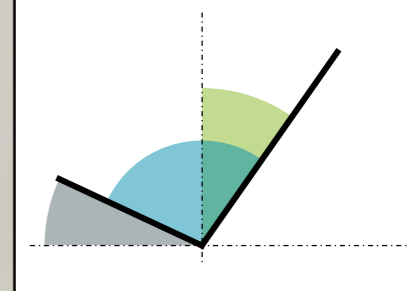

# Extended Use Position (25° // 35°)

**Male Participant**  
Height: 193 cm  
Seat Cushion 25°  
Backrest 35°  
Opening Angle 100°

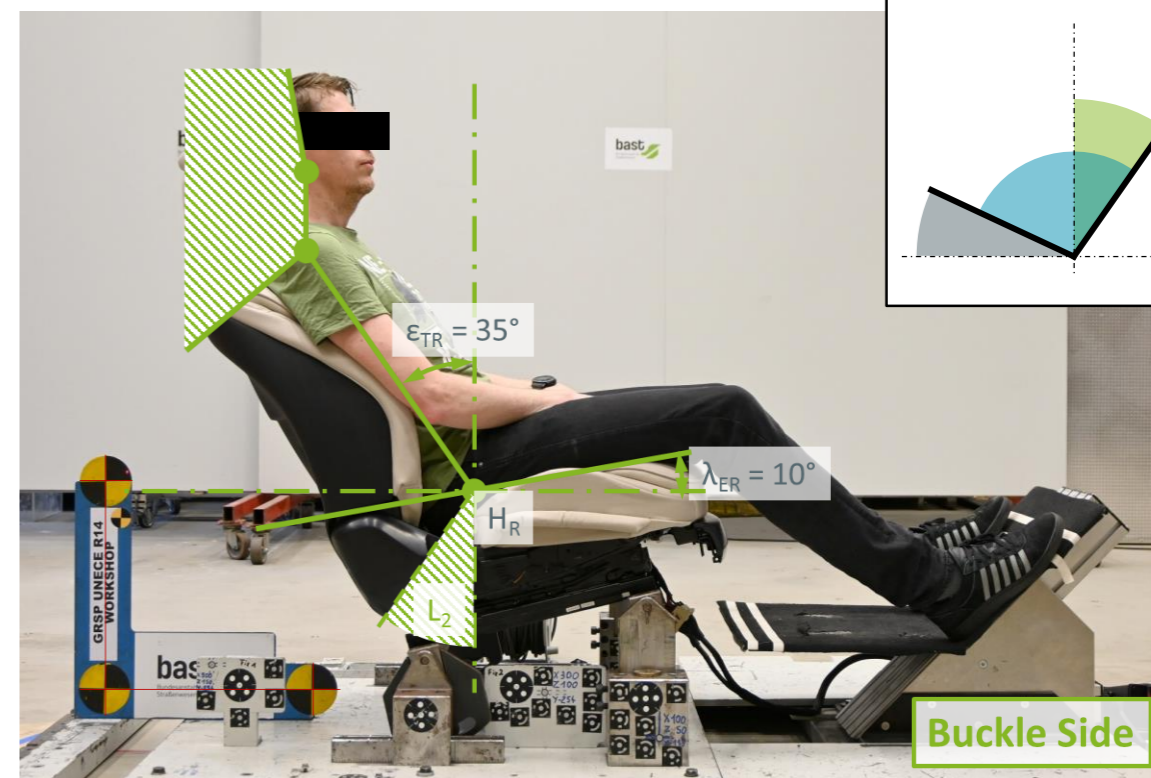
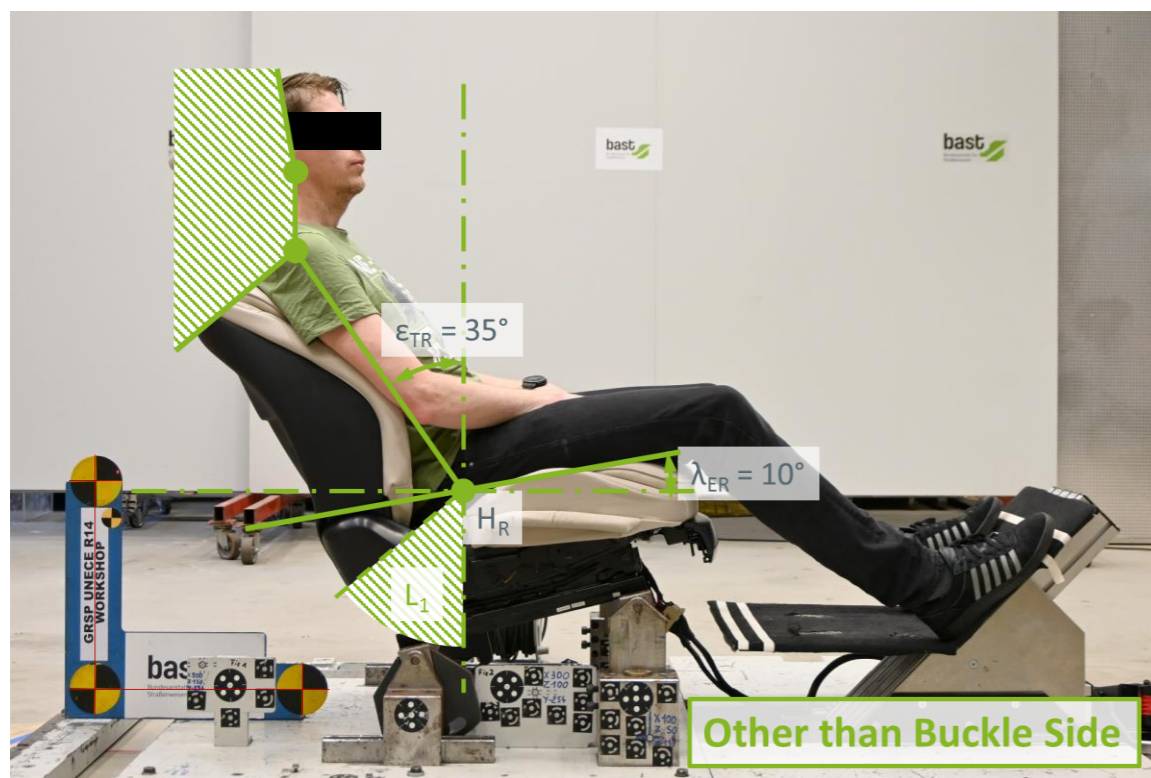
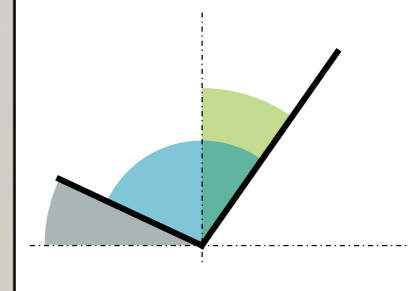

# Extended Use Position (25° // 45°)

- ▶ The seat cushion inclination is changed by 10° from the normal use, while the backrest inclination is changed by 20° from the normal use position
  - ▶ The  $E_R$ -Plane is tilted by the change in inclination of the seat cushion ( $\lambda_{ER} = 10^\circ$ )
  - ▶ The  $T_R$ -Plane is equivalent to the backrest angle ( $\epsilon_{TR} = 45^\circ$ )

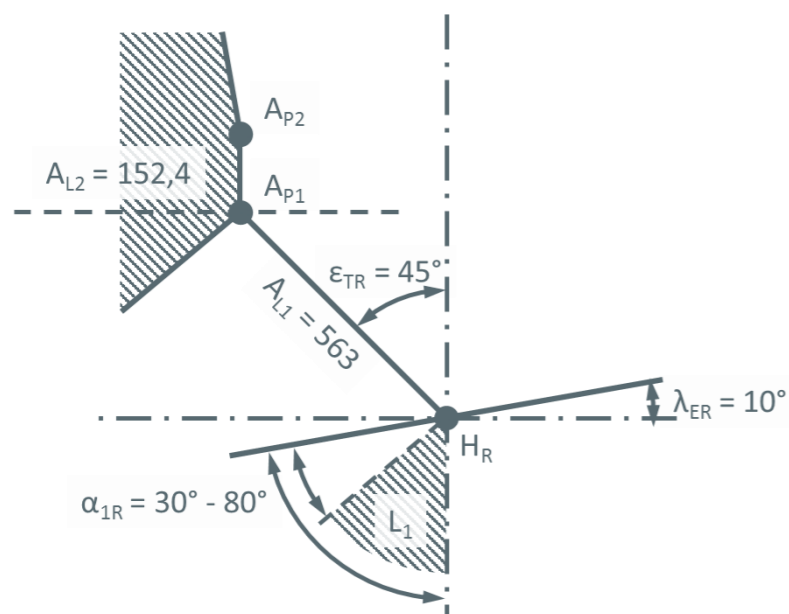

Other than Buckle Side

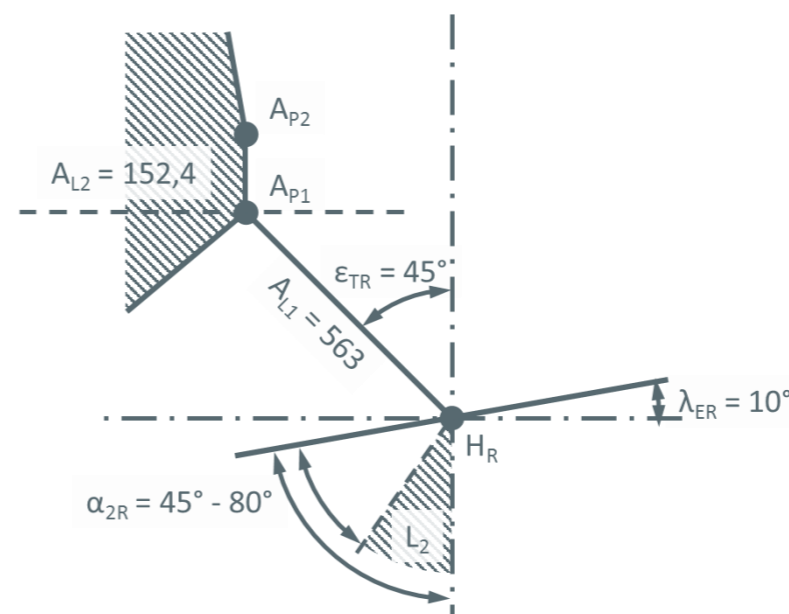

Buckle Side

## Configuration No. 5

Seat Cushion	25°
Backrest	45°
Opening Angle	110°

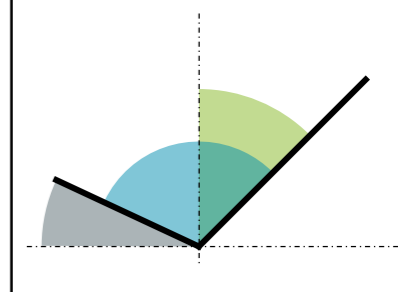

# Extended Use Position (25° // 45°)

- ▶ Similar H-Point as for configuration no. 4

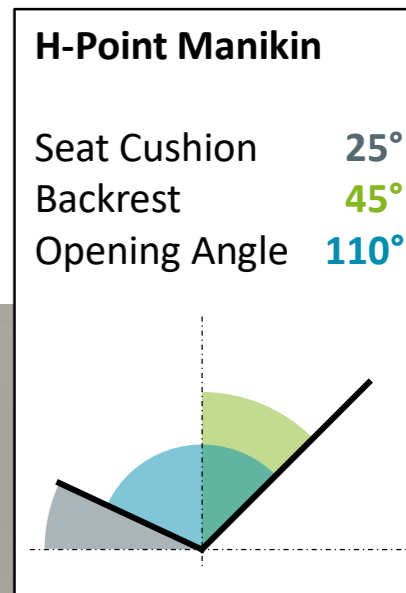
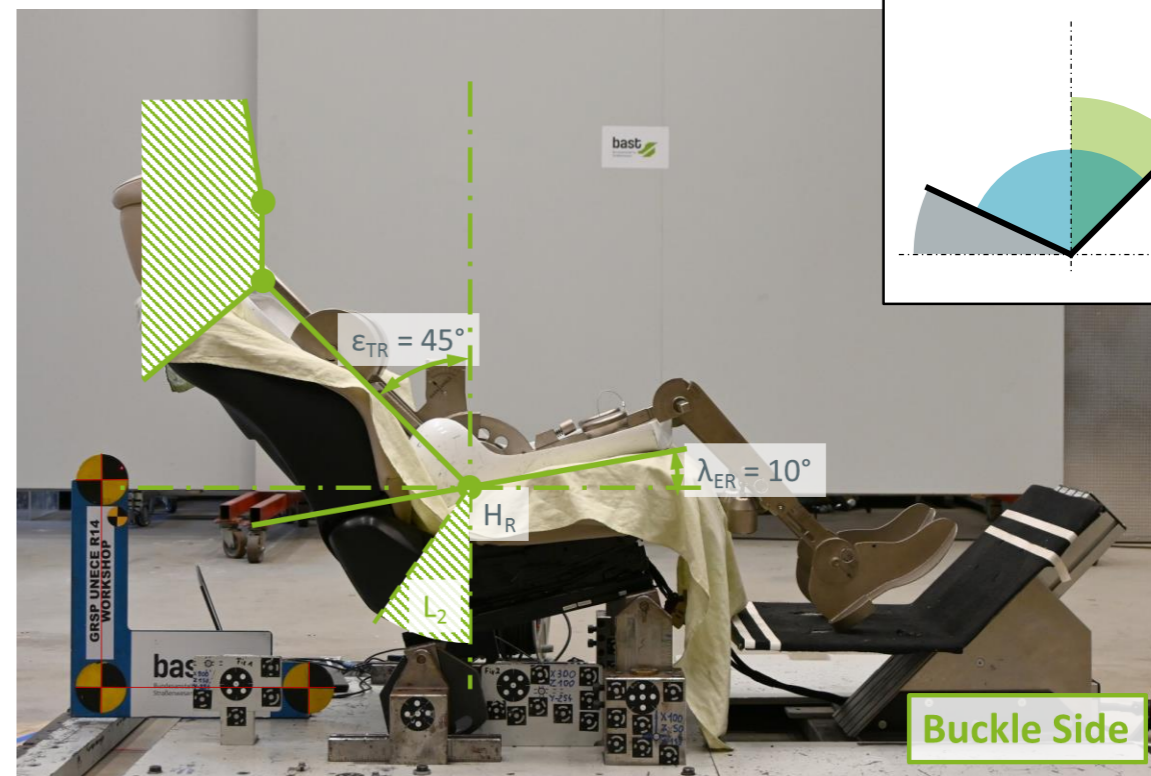
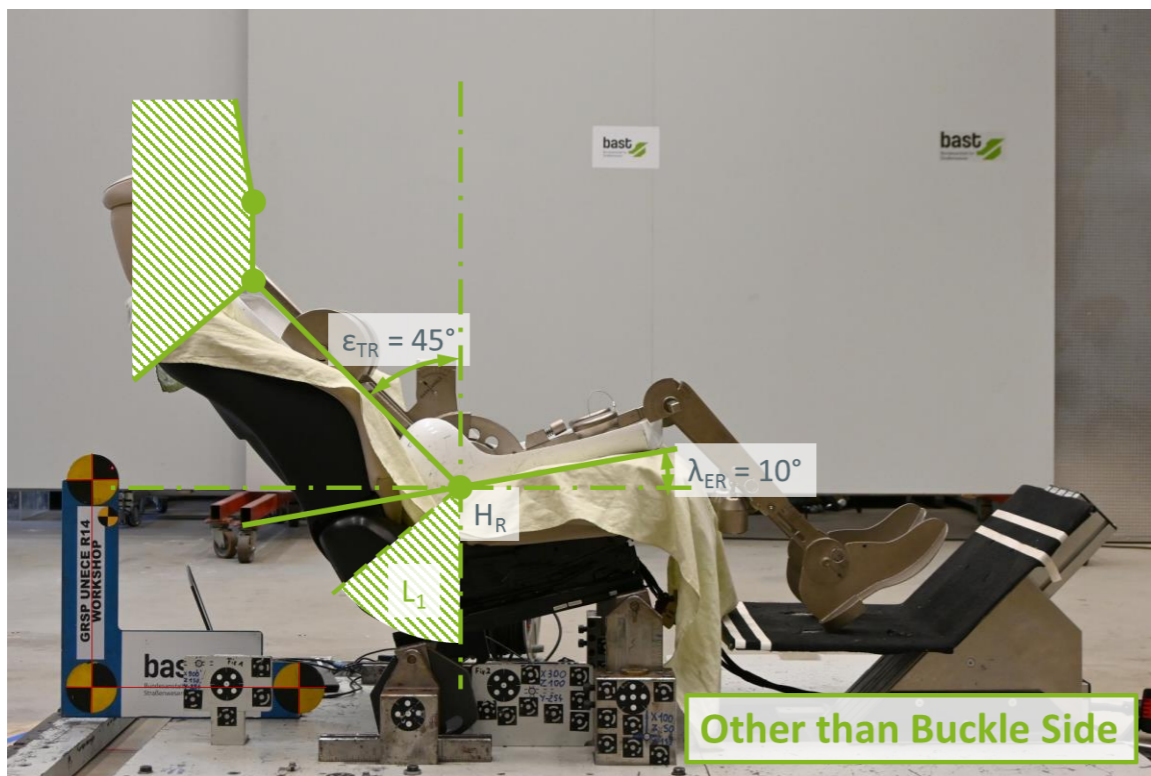

# Extended Use Position (25° // 45°)

## Hybrid III 5<sup>th</sup> Female

Seat Cushion 25°  
Backrest 45°  
Opening Angle 110°

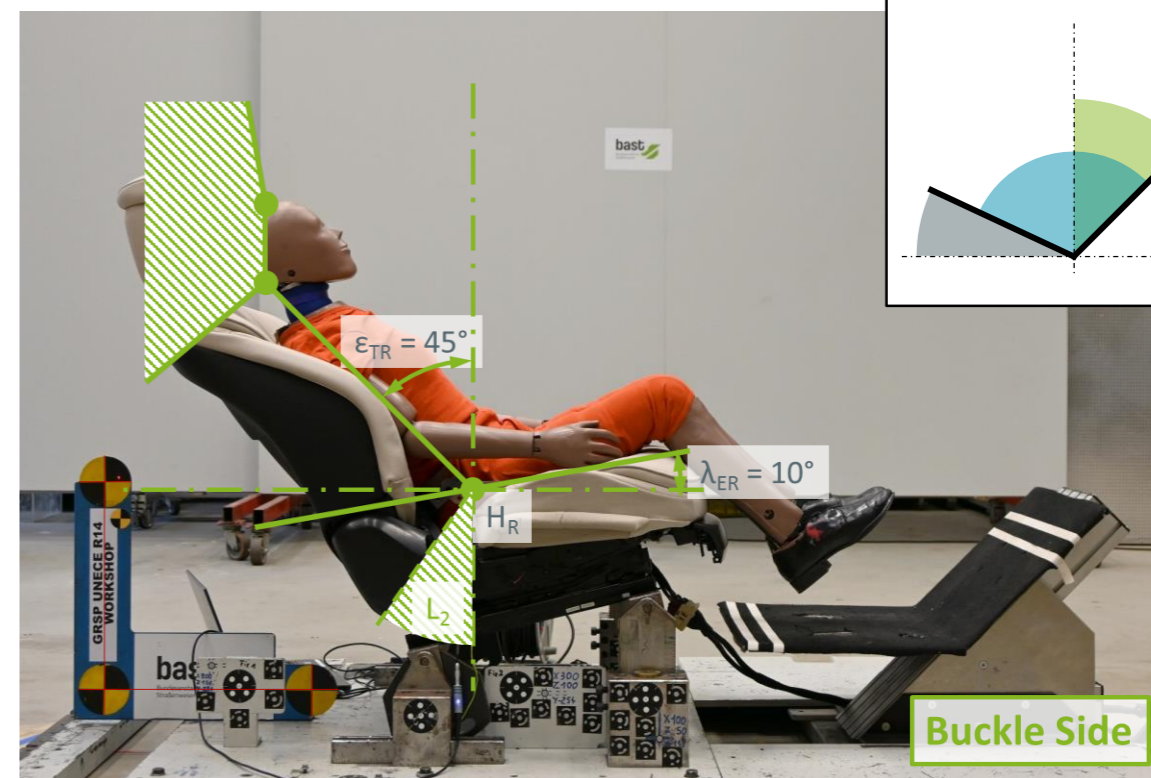
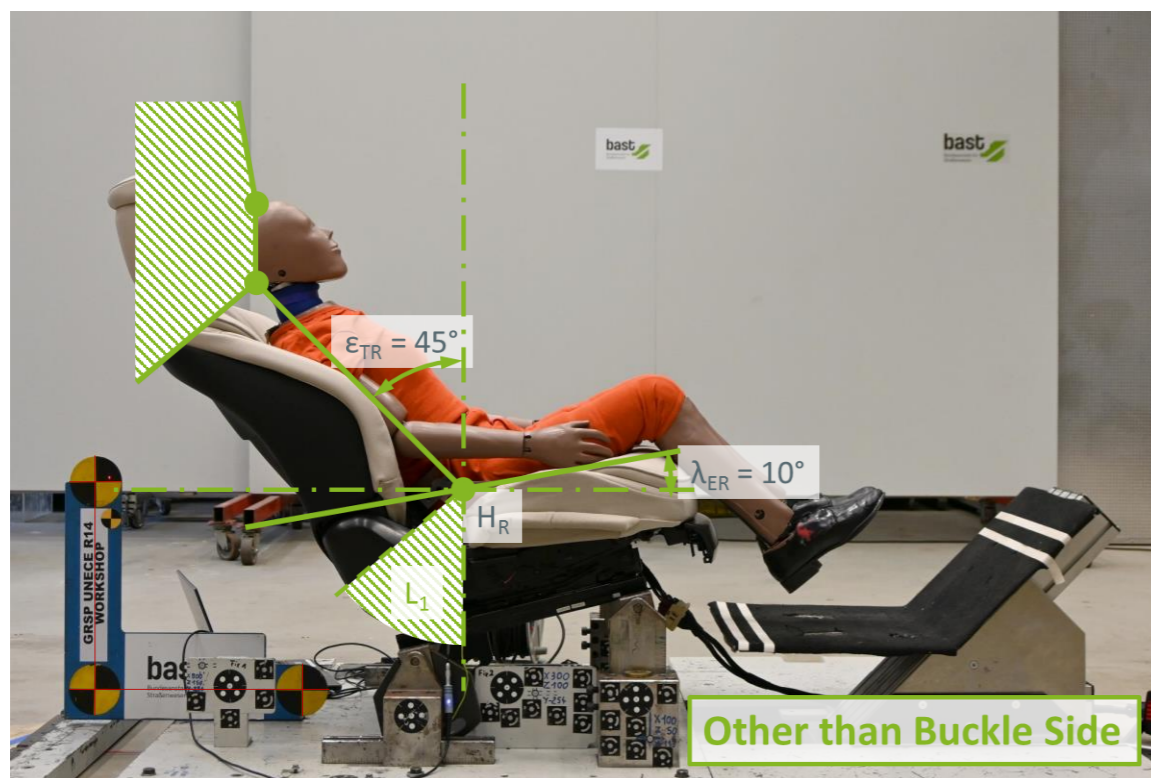
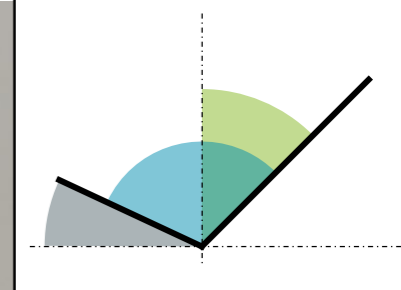



# Extended Use Position (25° // 45°)

## Hybrid III 95<sup>th</sup> Male

Seat Cushion 25°  
Backrest 45°  
Opening Angle 110°

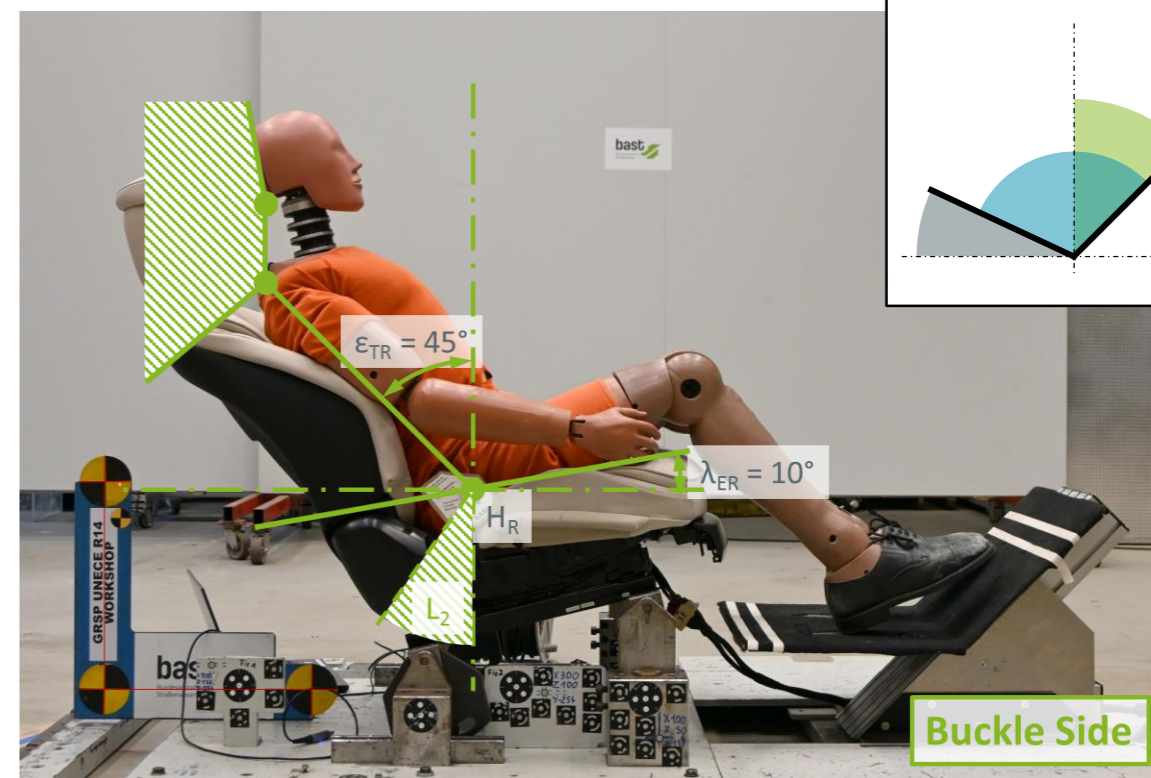
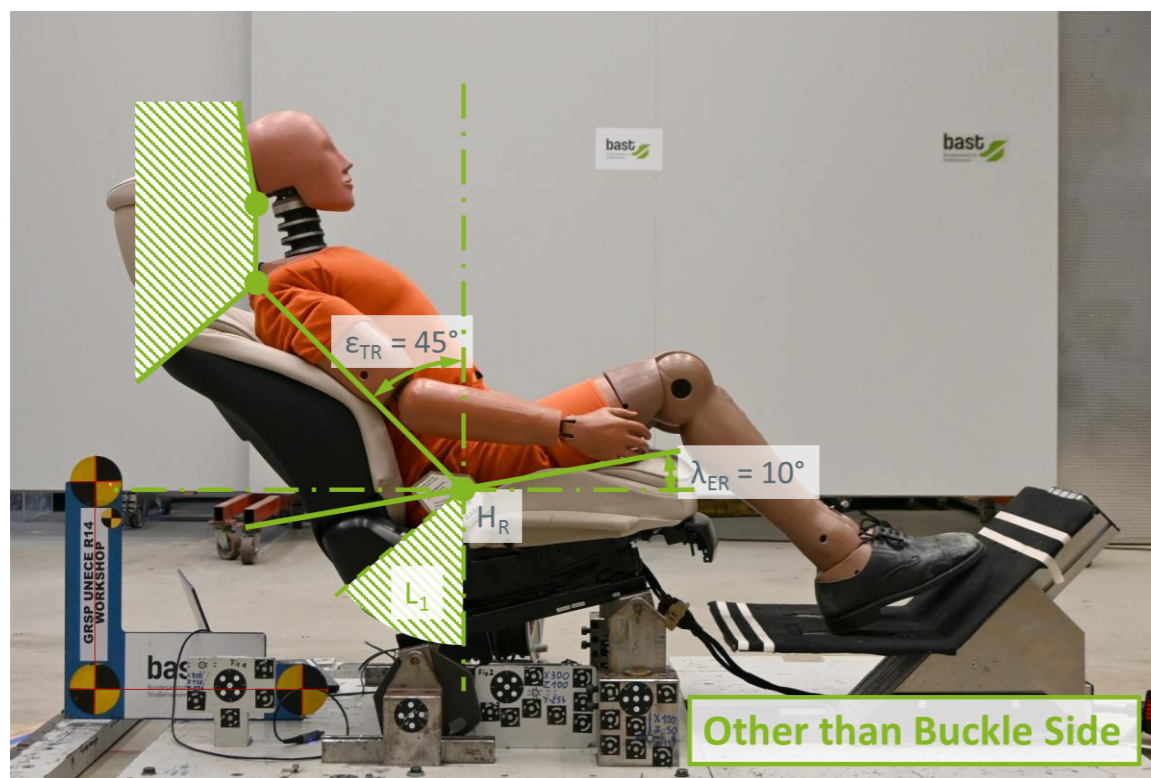
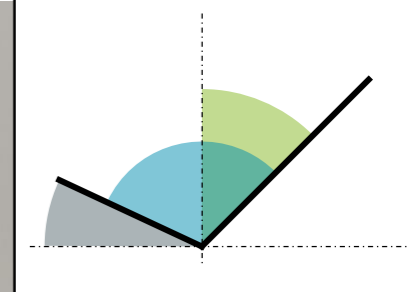

# Extended Use Position (25° // 45°)

## THOR-50M

Seat Cushion 25°  
Backrest 45°  
Opening Angle 110°

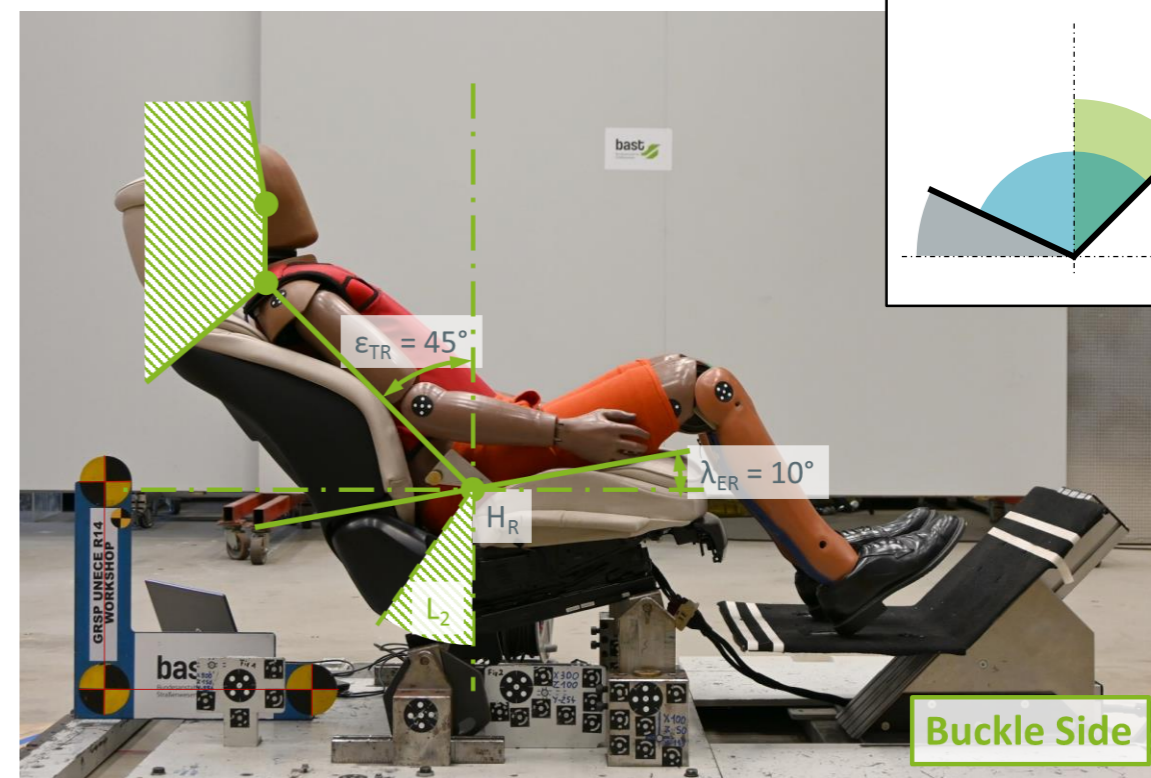
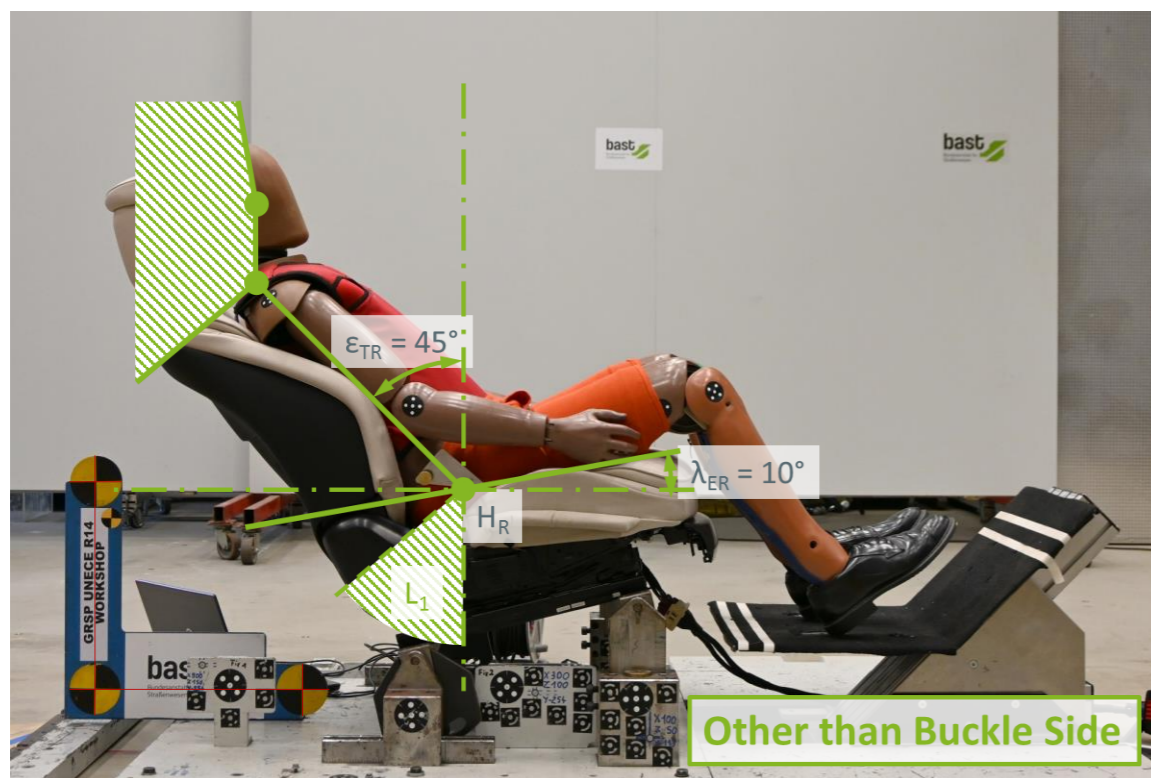
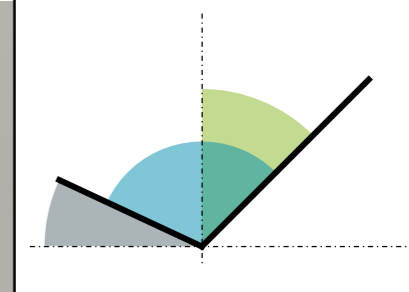



# Extended Use Position (25° // 45°)

## THOR-RS-50M

Seat Cushion 25°  
Backrest 45°  
Opening Angle 110°

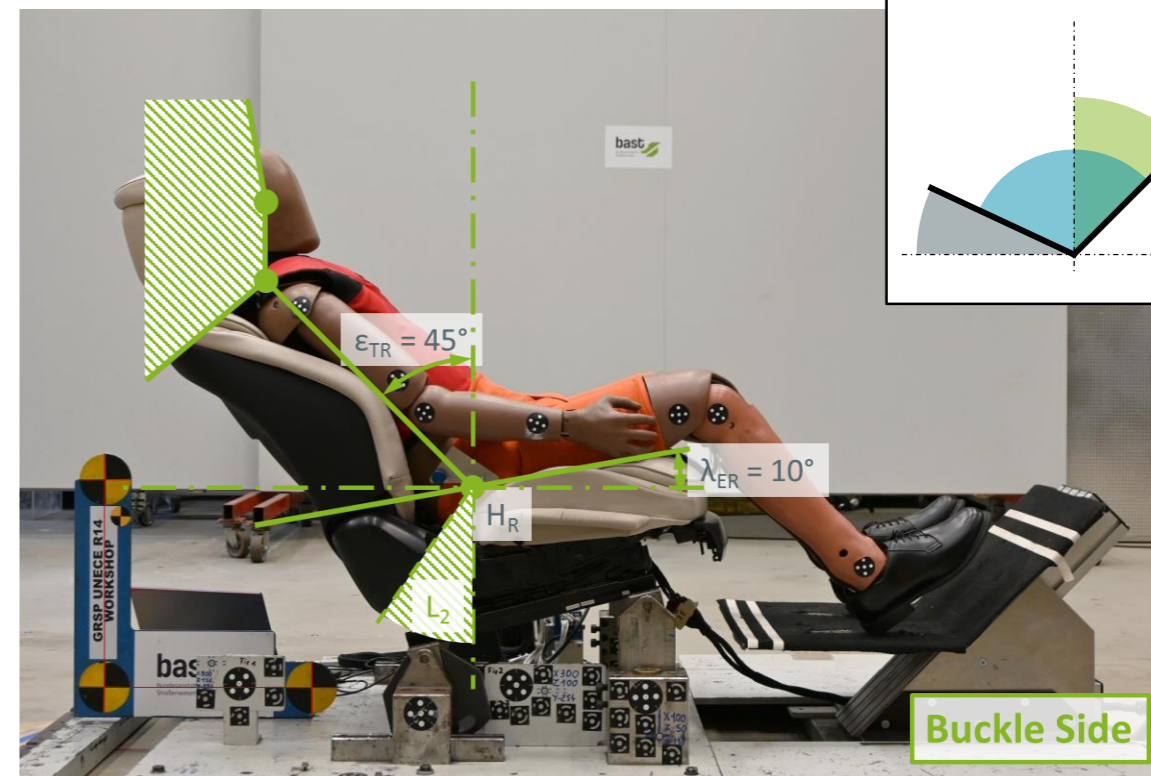
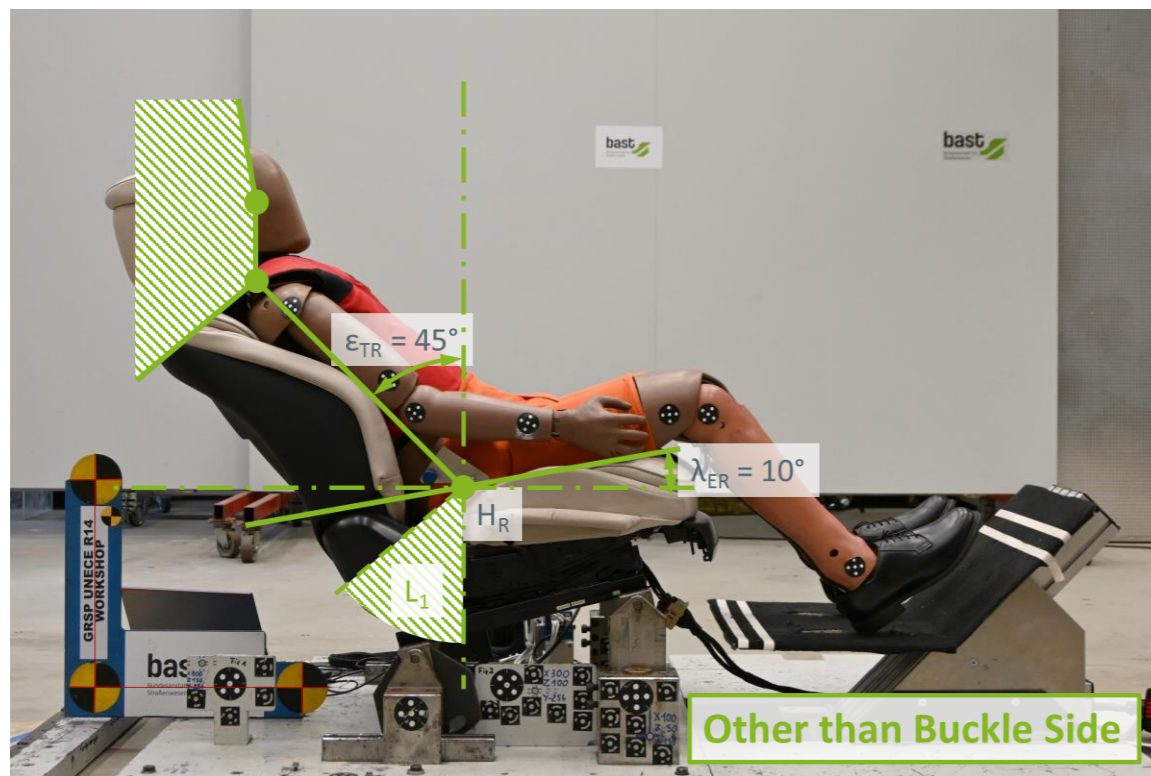
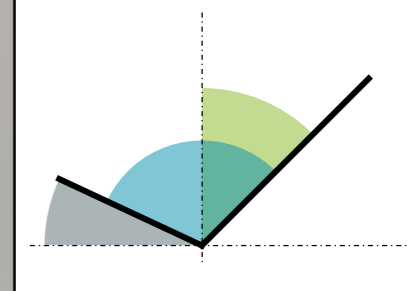

# Extended Use Position (25° // 45°)

**Male Participant**  
Height: 170 cm  
Seat Cushion 25°  
Backrest 45°  
Opening Angle 110°

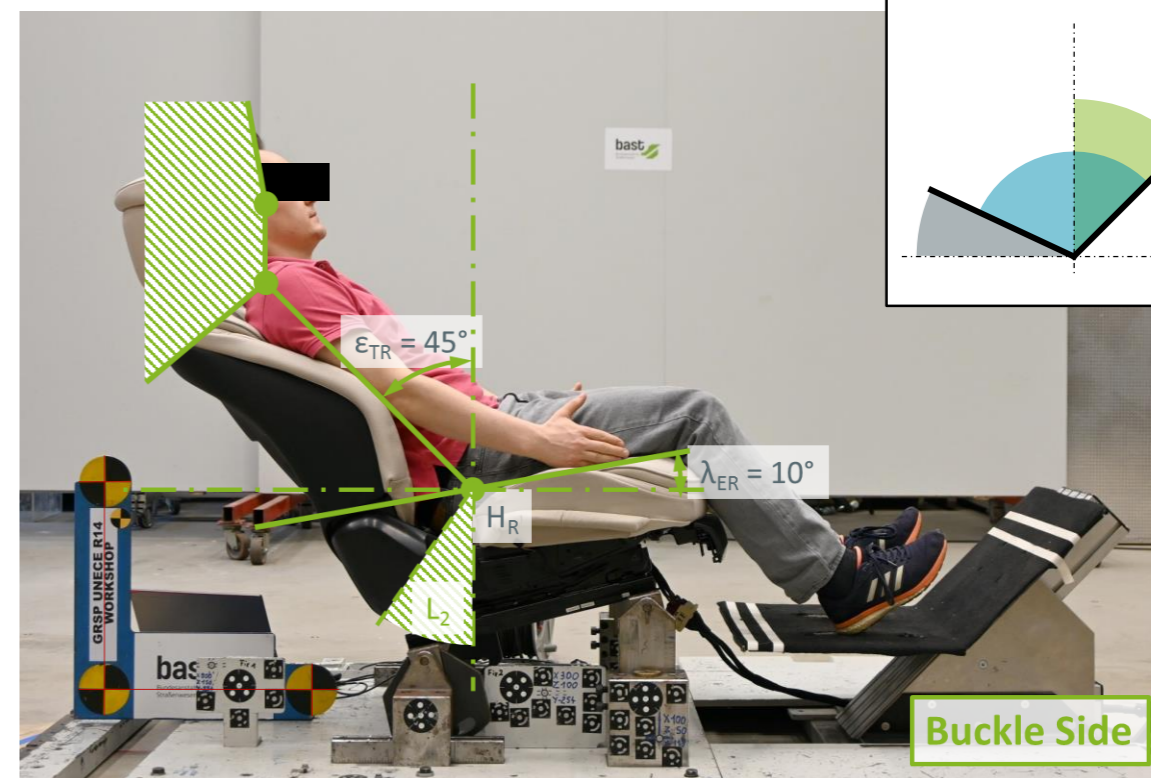
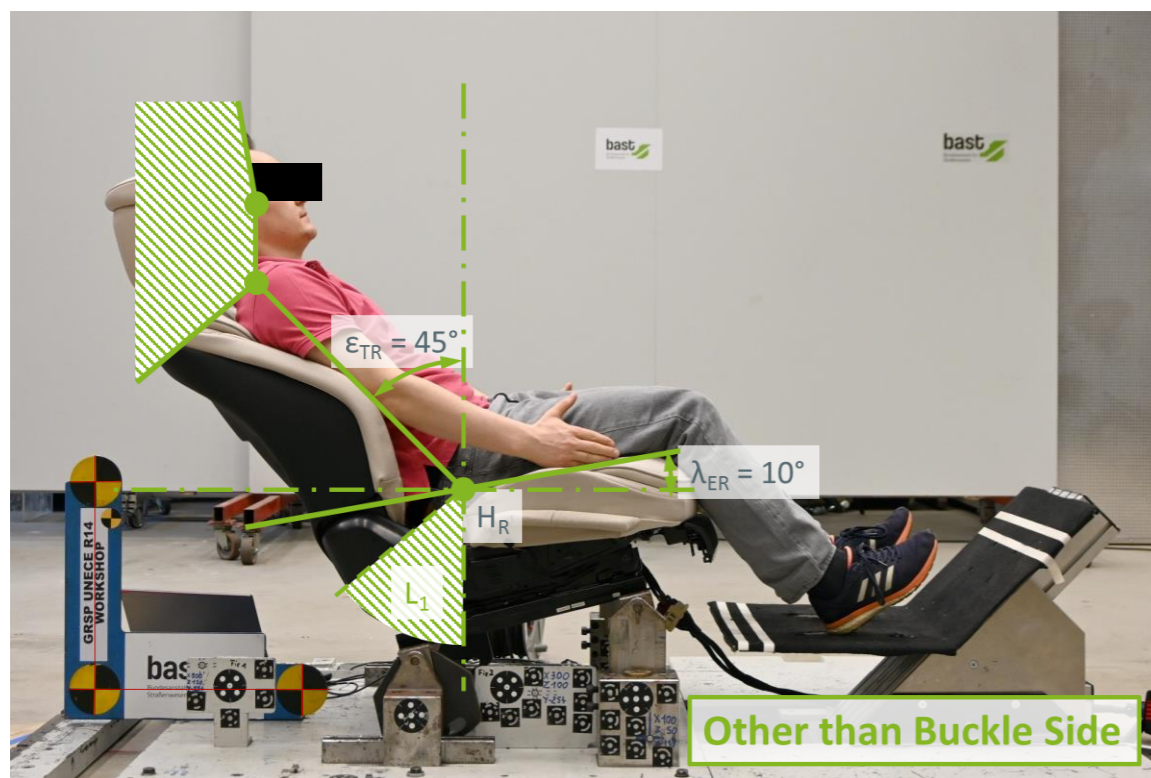
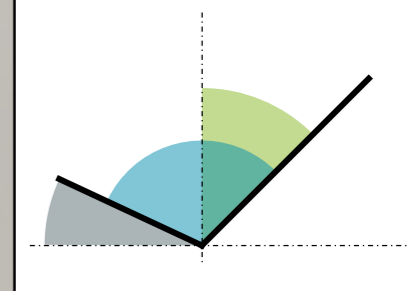

# Extended Use Position (25° // 45°)

**Male Participant**  
Height: 193 cm  
Seat Cushion 25°  
Backrest 45°  
Opening Angle 110°

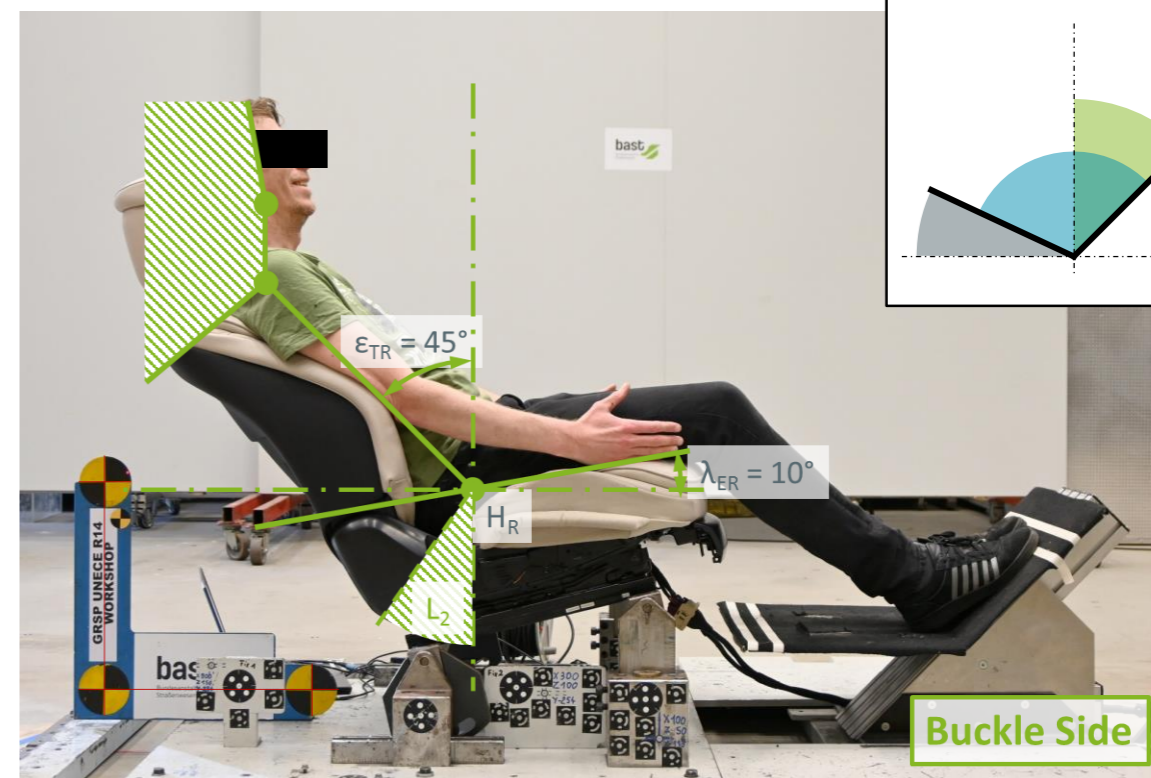
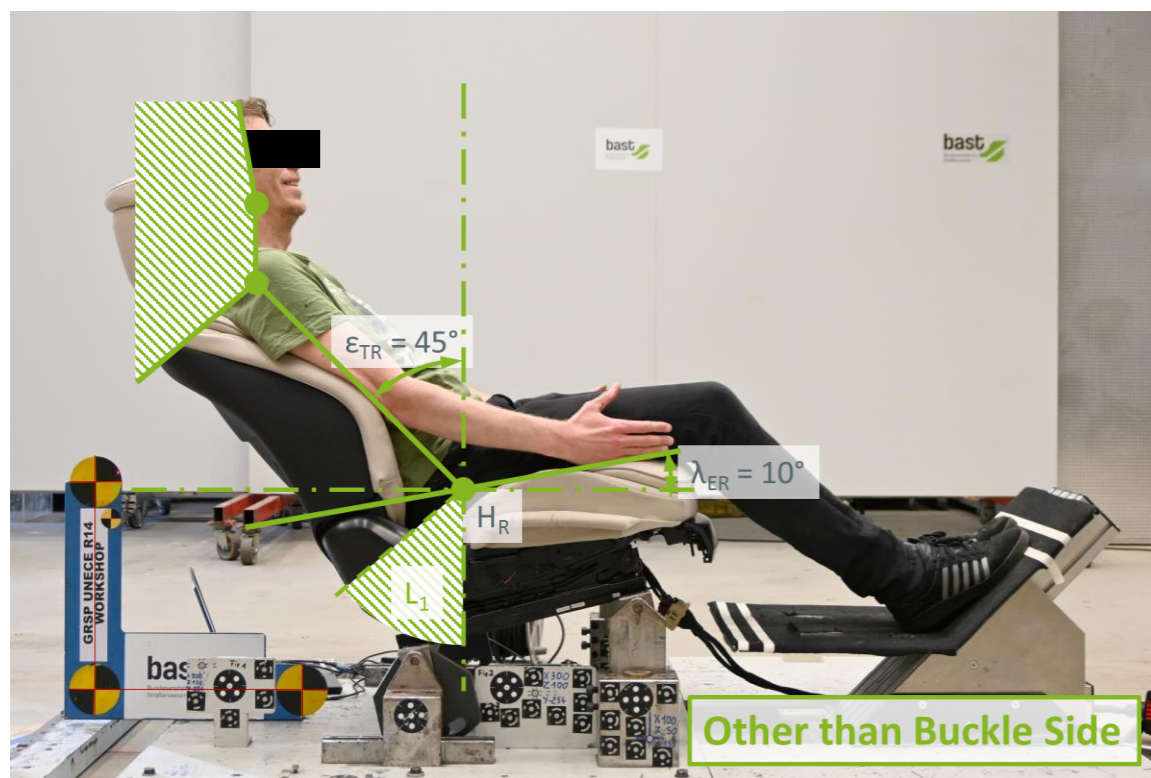
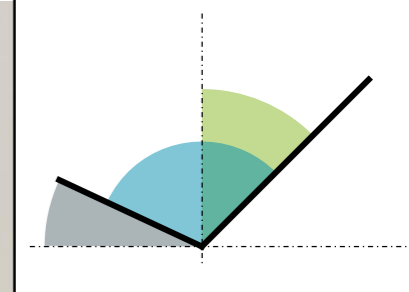

# Extended Use Position (25° // 45°)

**Male Participant**  
Height: unknown  
Seat Cushion 25°  
Backrest 45°  
Opening Angle 110°

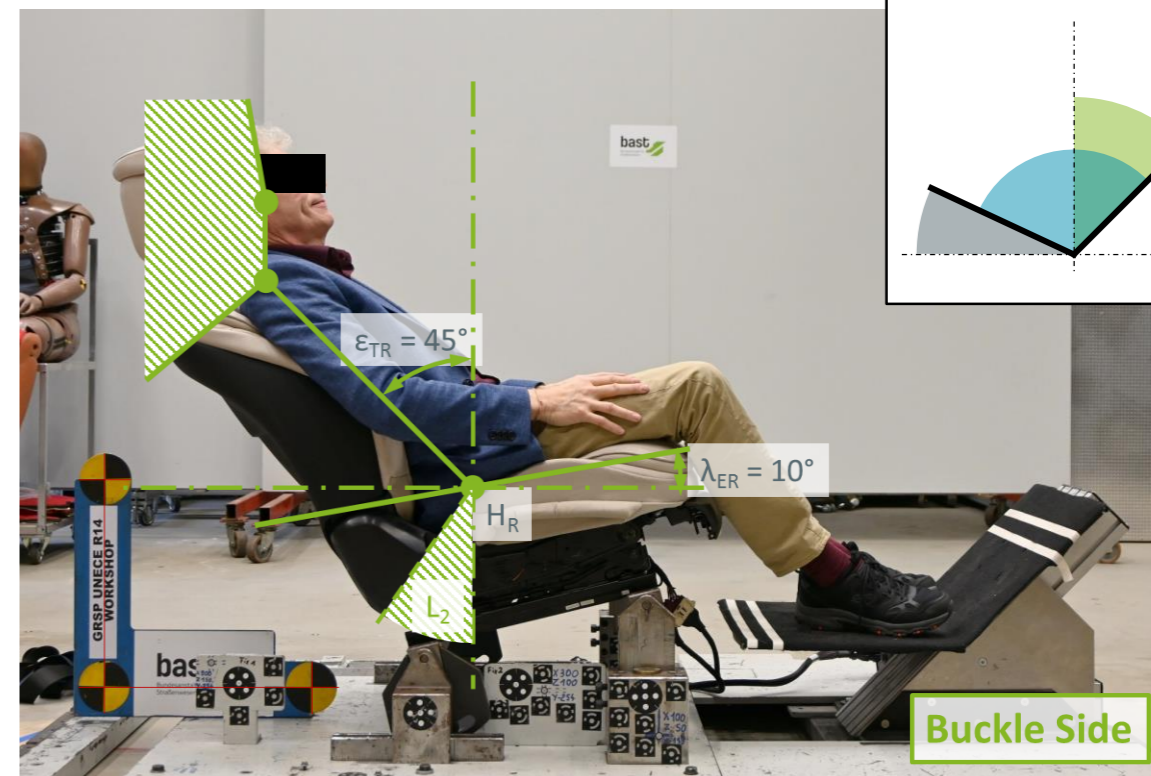
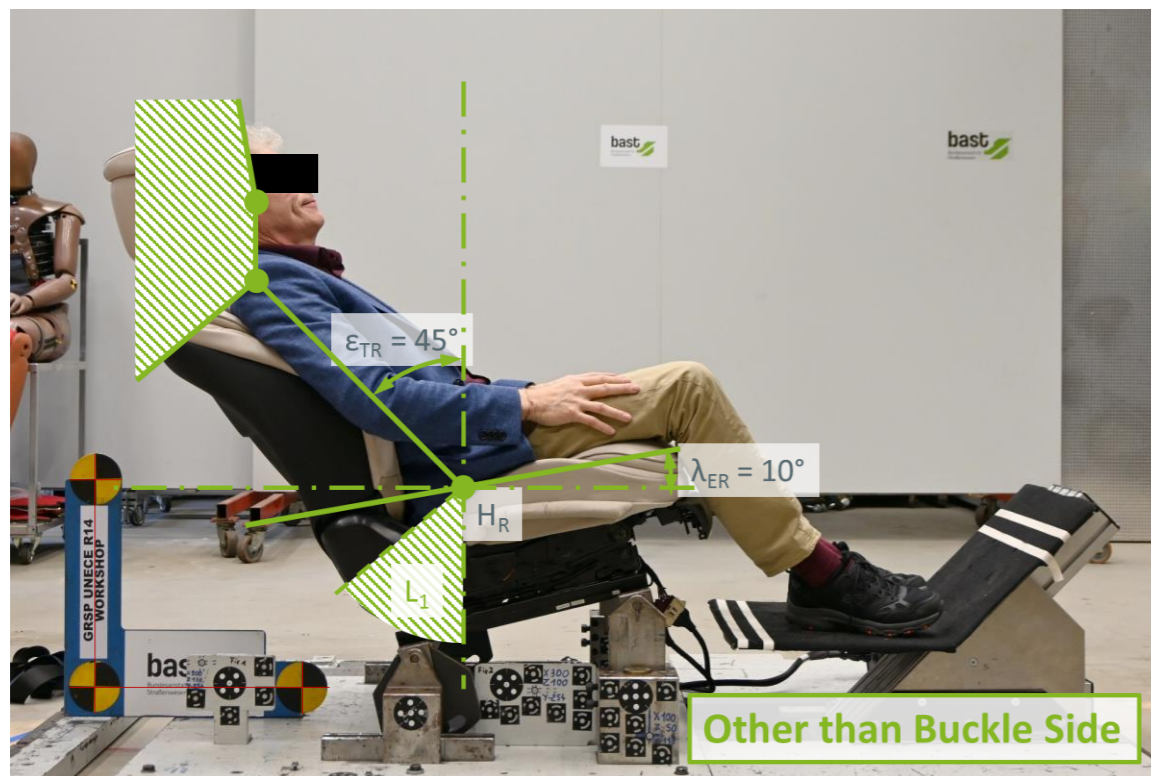
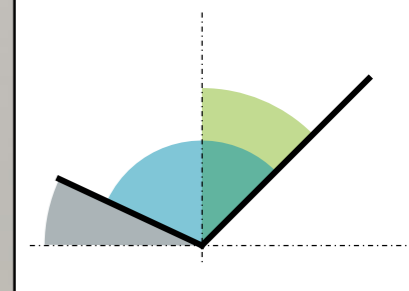

# Extended Use Position (25° // 45°)

**Male Participant**  
Height: unknown  
Seat Cushion 25°  
Backrest 45°  
Opening Angle 110°

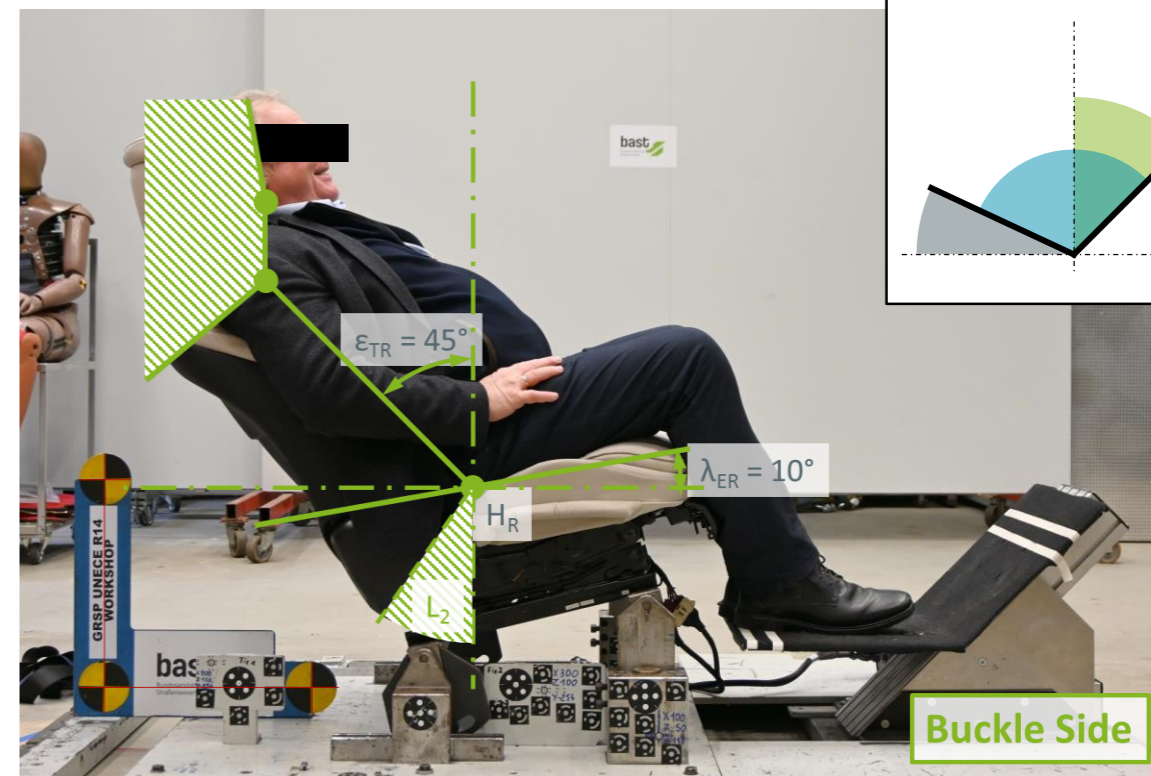
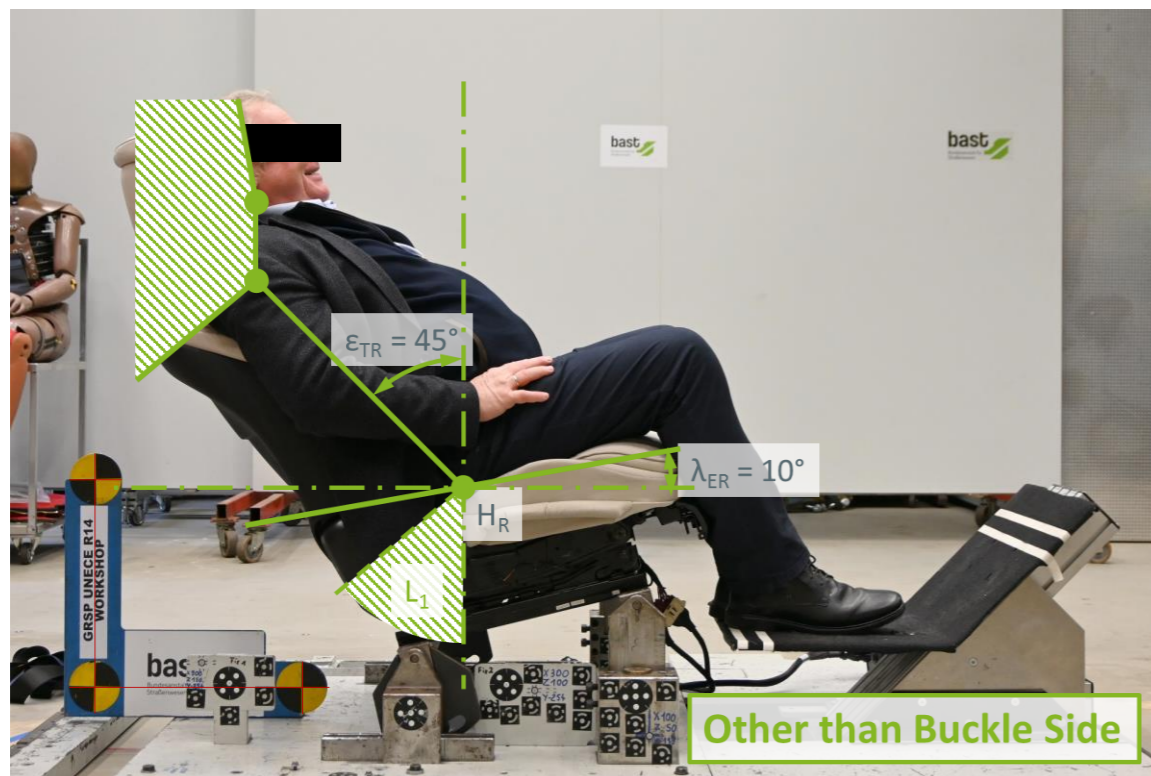
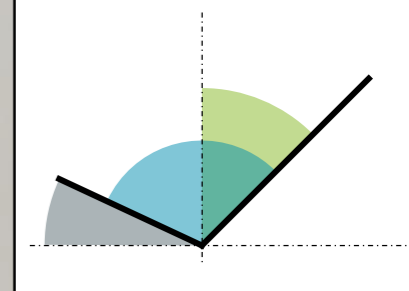

# Extended Use Position (25° // 45°)

**Male Participant**  
Height: unknown  
Seat Cushion 25°  
Backrest 45°  
Opening Angle 110°

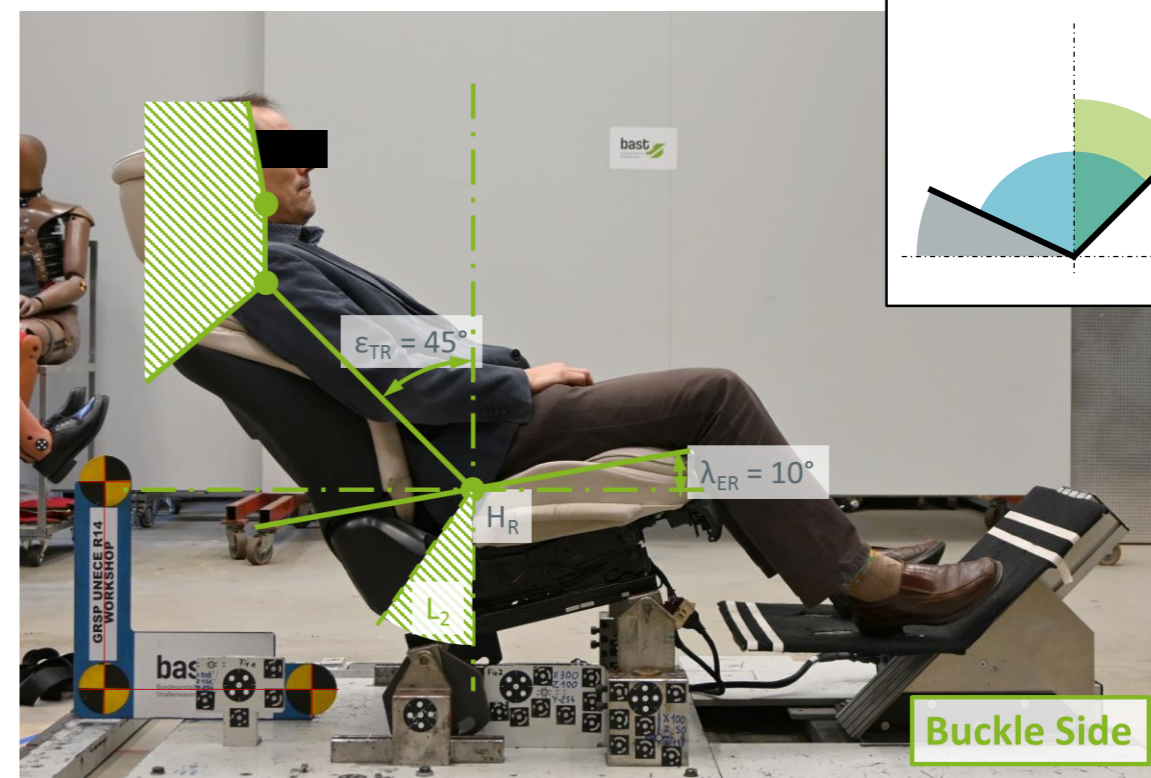
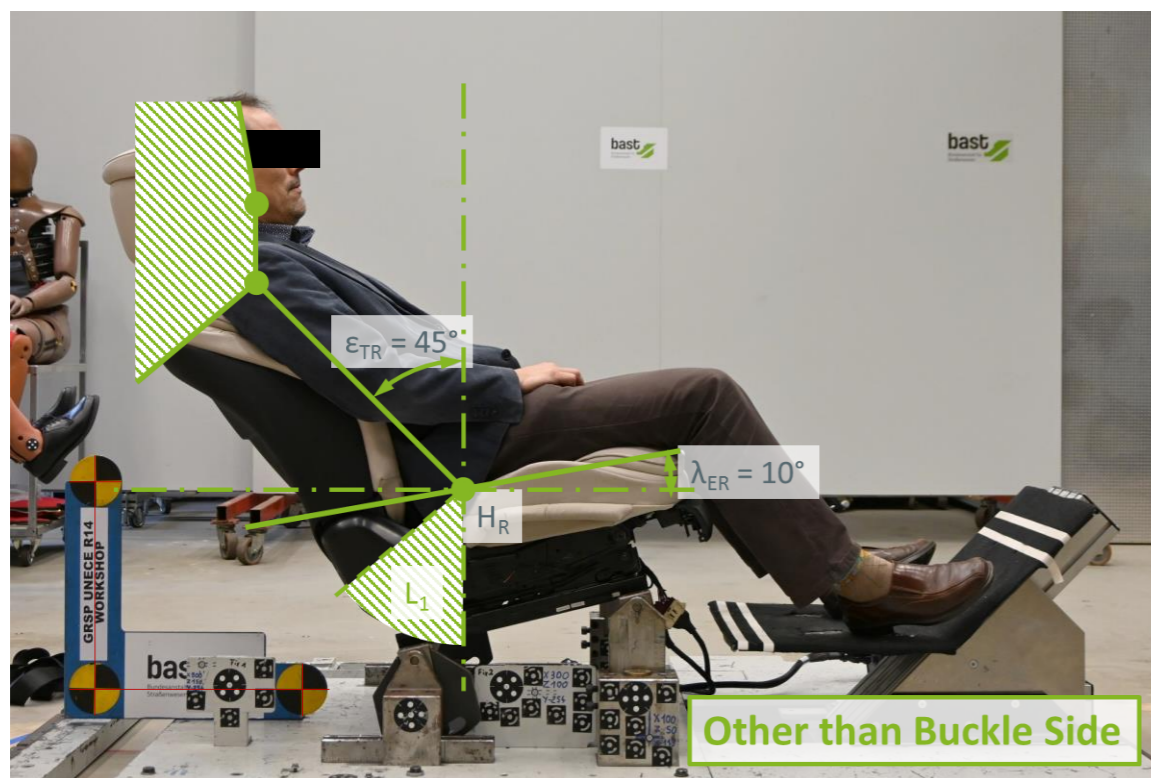
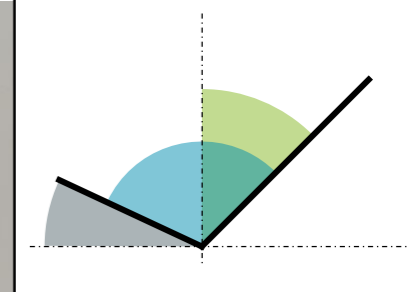

# Extended Use Position (25° // 45°)

**Male Participant**  
Height: unknown  
Seat Cushion 25°  
Backrest 45°  
Opening Angle 110°

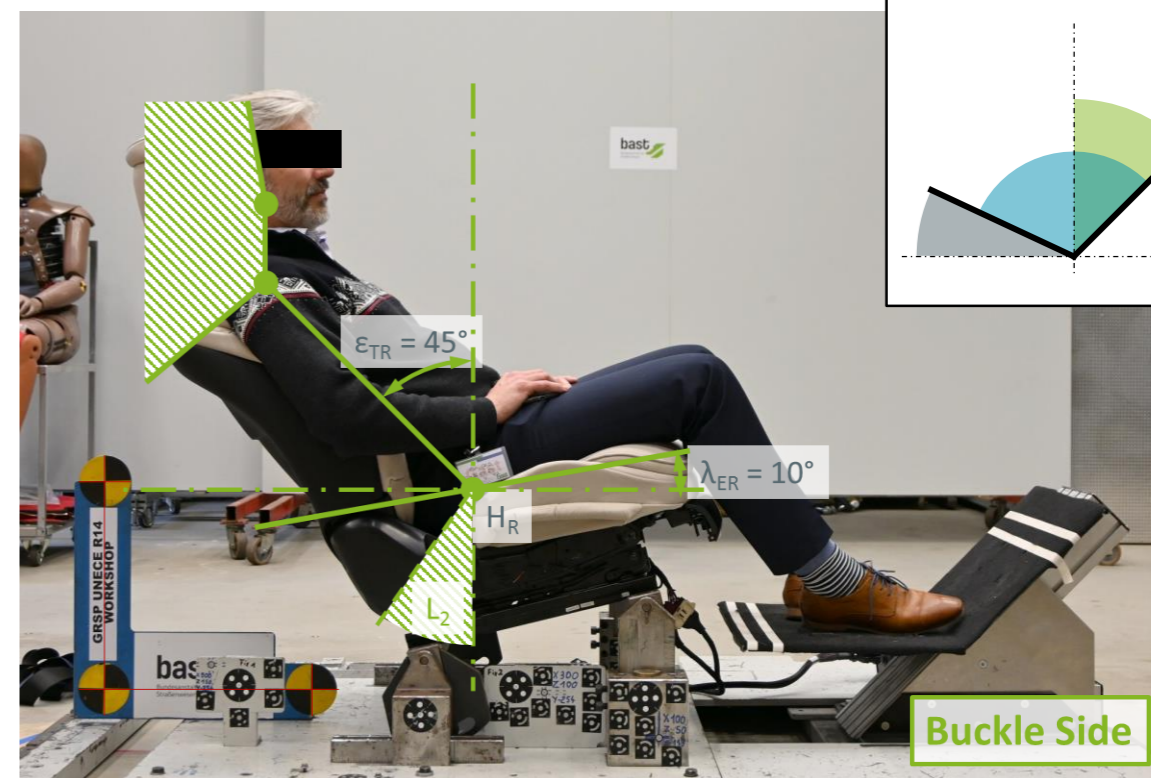
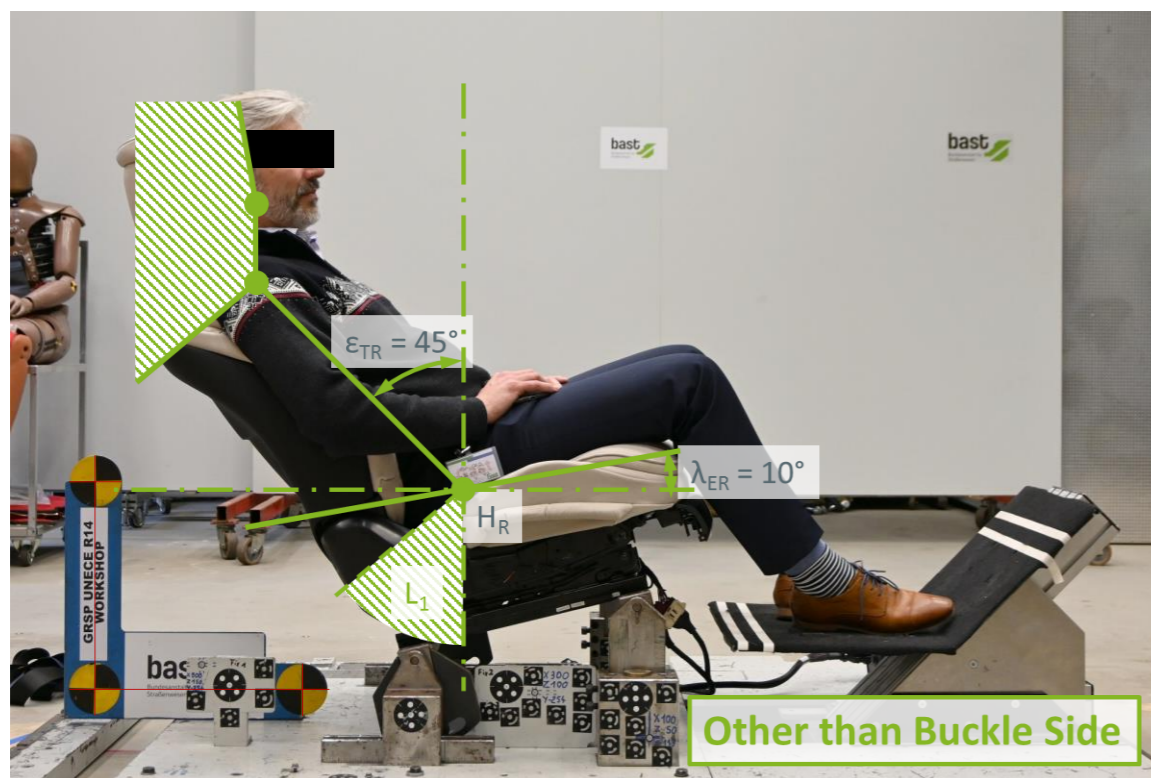
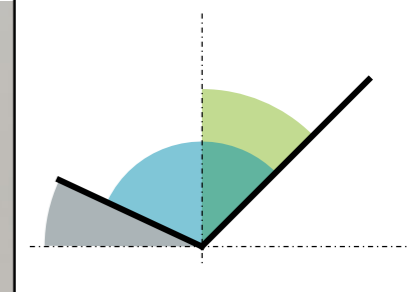

# Extended Use Position (25° // 45°)

**Male Participant**  
Height: unknown  
Seat Cushion 25°  
Backrest 45°  
Opening Angle 110°

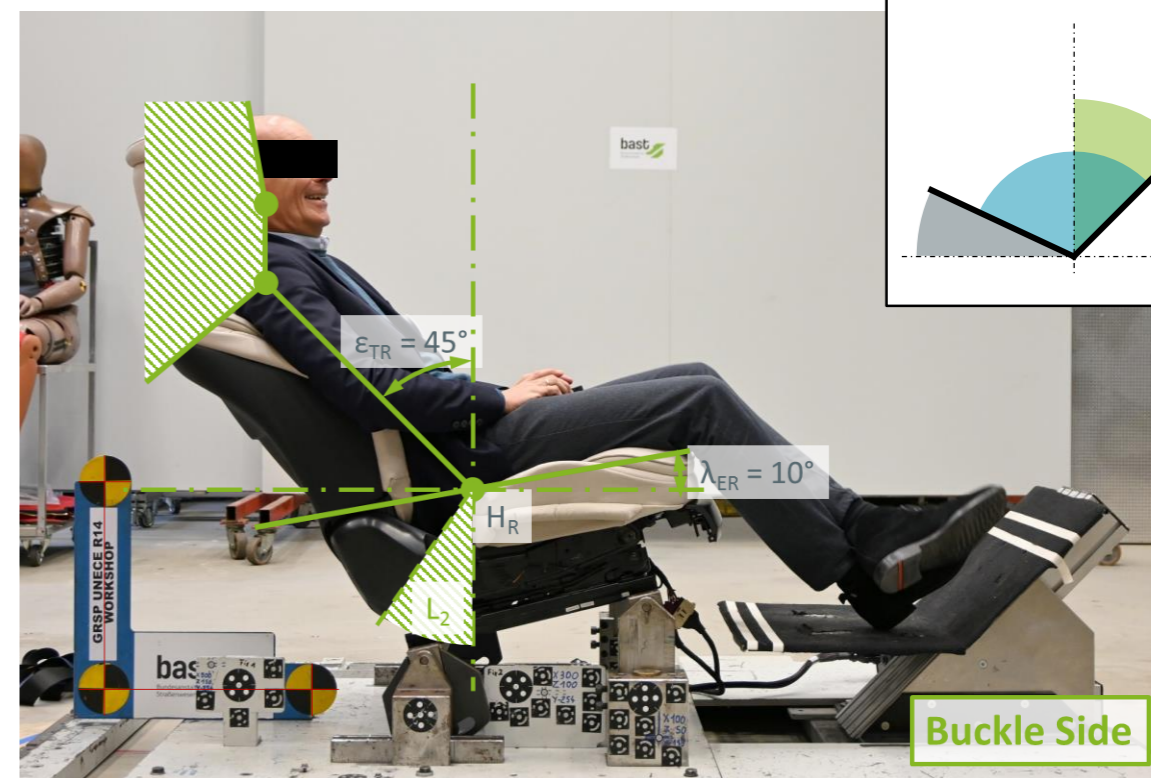
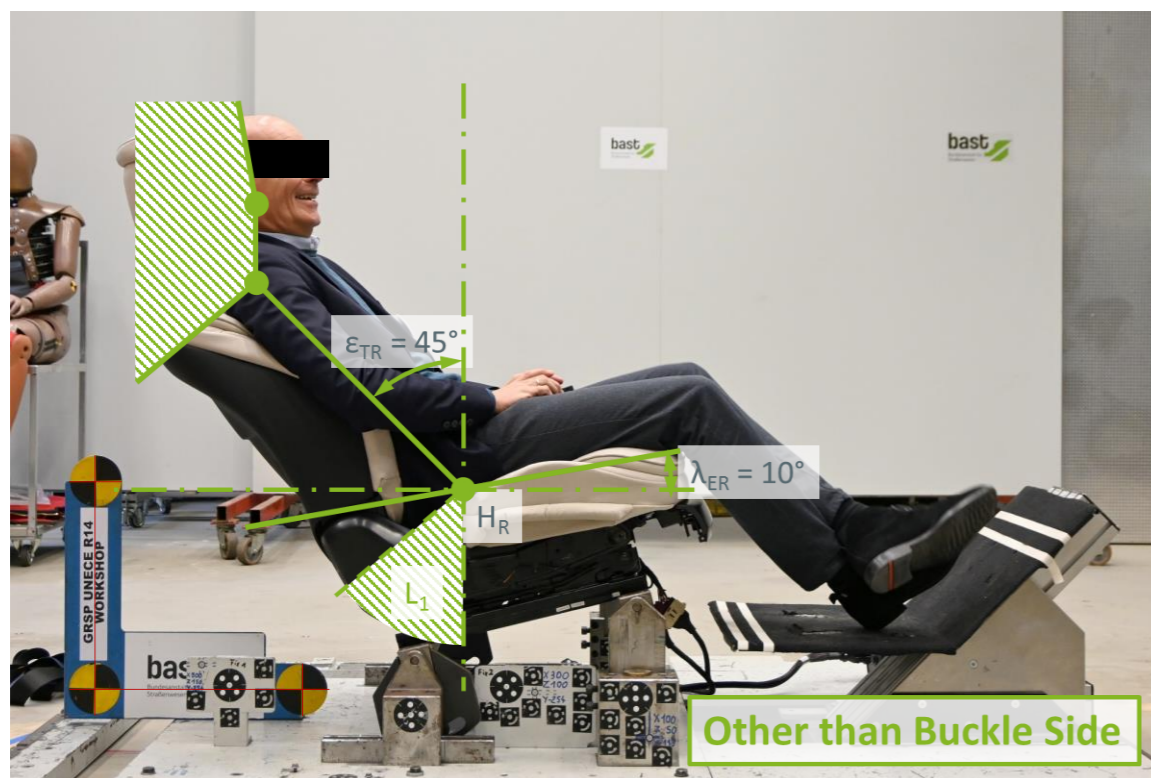
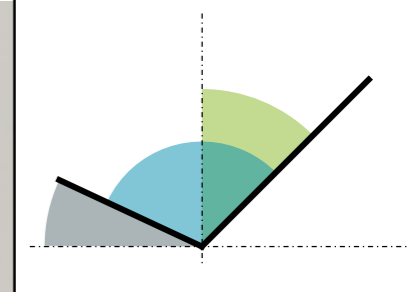



# Extended Use Position (25° // 55°)

- ▶ The seat cushion inclination is changed by 10° from the normal use, while the backrest inclination is changed by 30° from the normal use position
  - ▶ The  $E_R$ -Plane is tilted by the change in inclination of the seat cushion ( $\lambda_{ER} = 10^\circ$ )
  - ▶ The  $T_R$ -Plane is equivalent to the backrest angle ( $\epsilon_{TR} = 55^\circ$ )

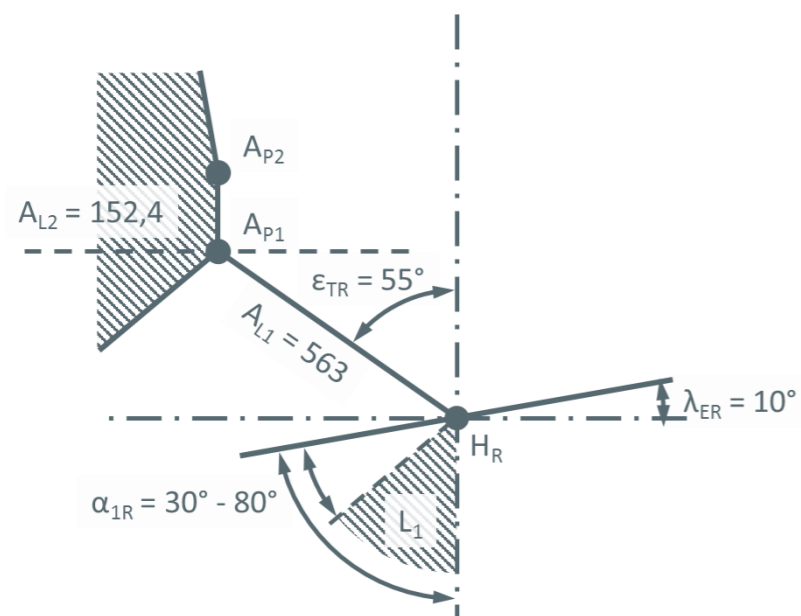

Other than Buckle Side

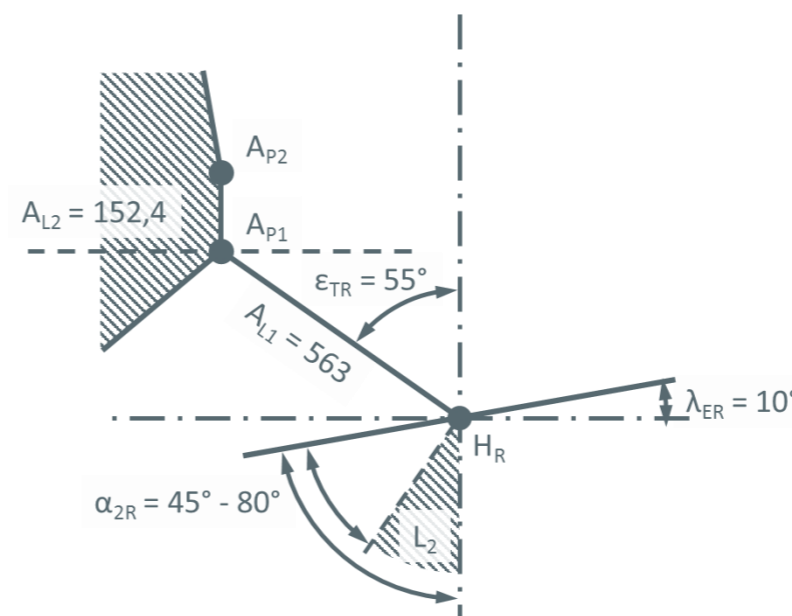

Buckle Side

## Configuration No. 6

Seat Cushion	25°
Backrest	55°
Opening Angle	120°

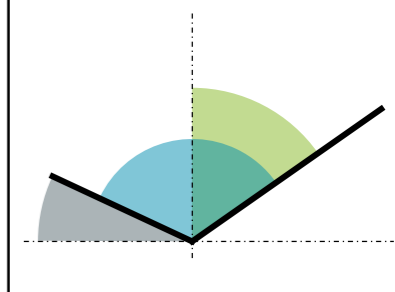

# Extended Use Position (25° // 55°)

- ▶ As the upper body of the H-Point manikin is reclined against the backrest, the H-point is pushed backwards and upwards by approximately 10 mm
  - ▶ Different behaviour compared to configuration no. 3

## H-Point Manikin

Seat Cushion	25°
Backrest	55°
Opening Angle	120°

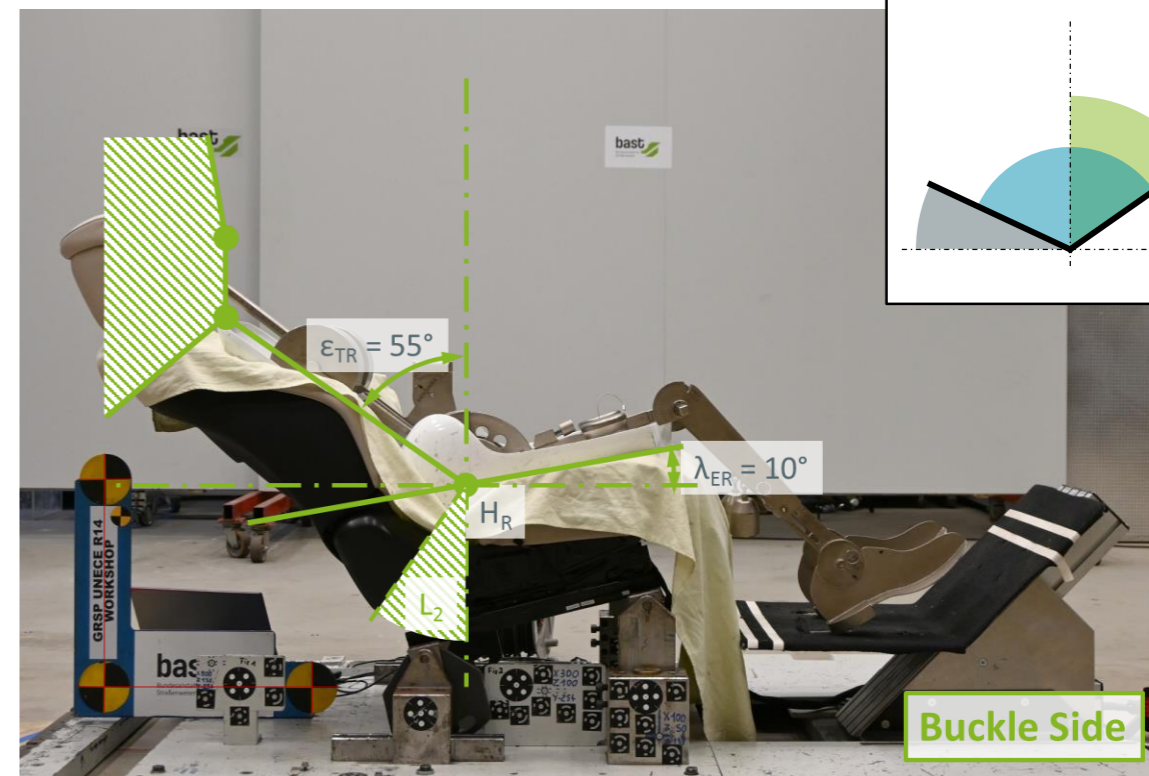
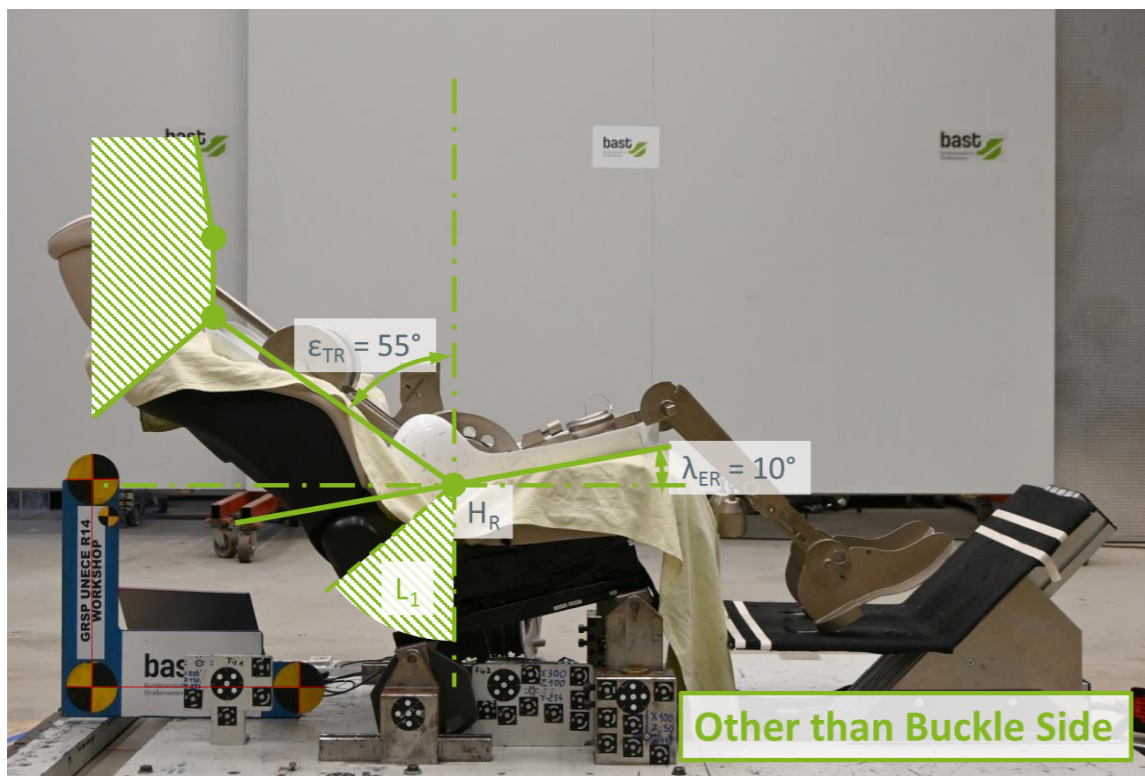
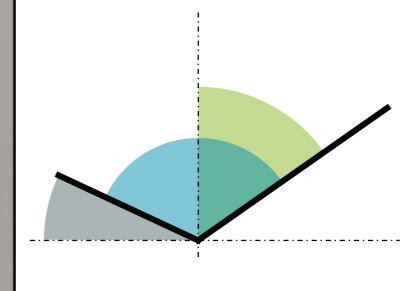

# Extended Use Position (25° // 55°)

- ▶ No continuous contact between the dummy's back and seatback

## Hybrid III 5<sup>th</sup> Female

Seat Cushion	25°
Backrest	55°
Opening Angle	120°

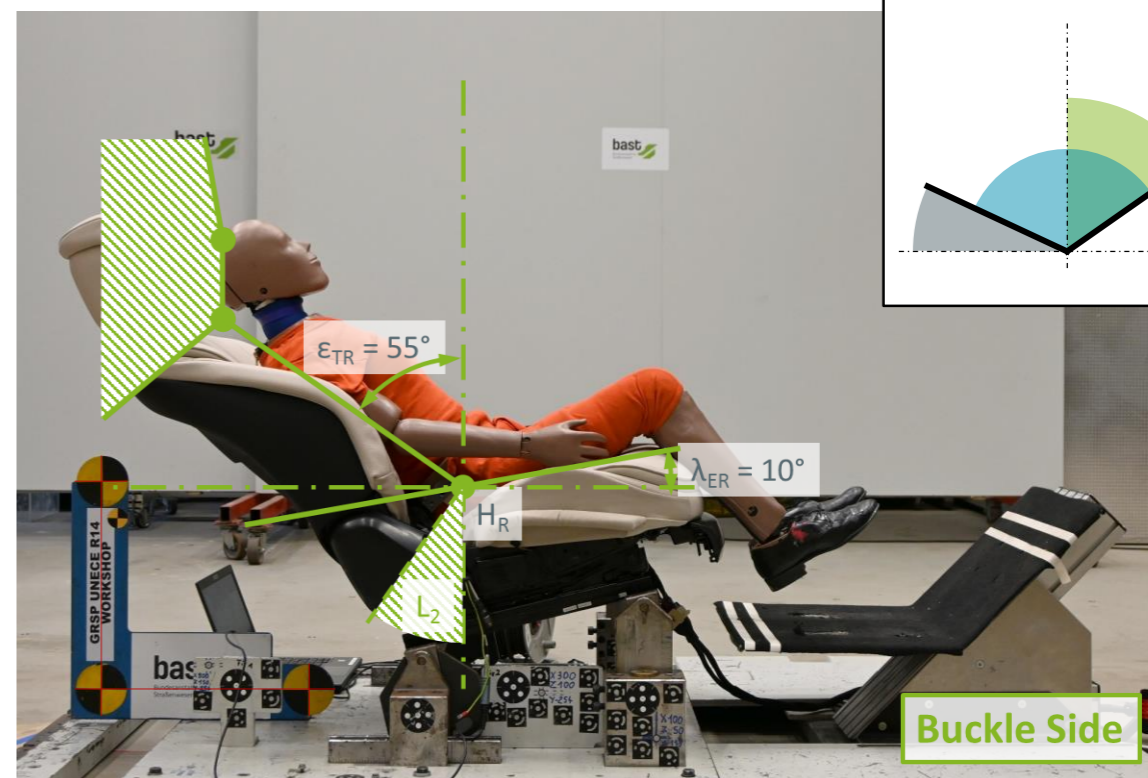
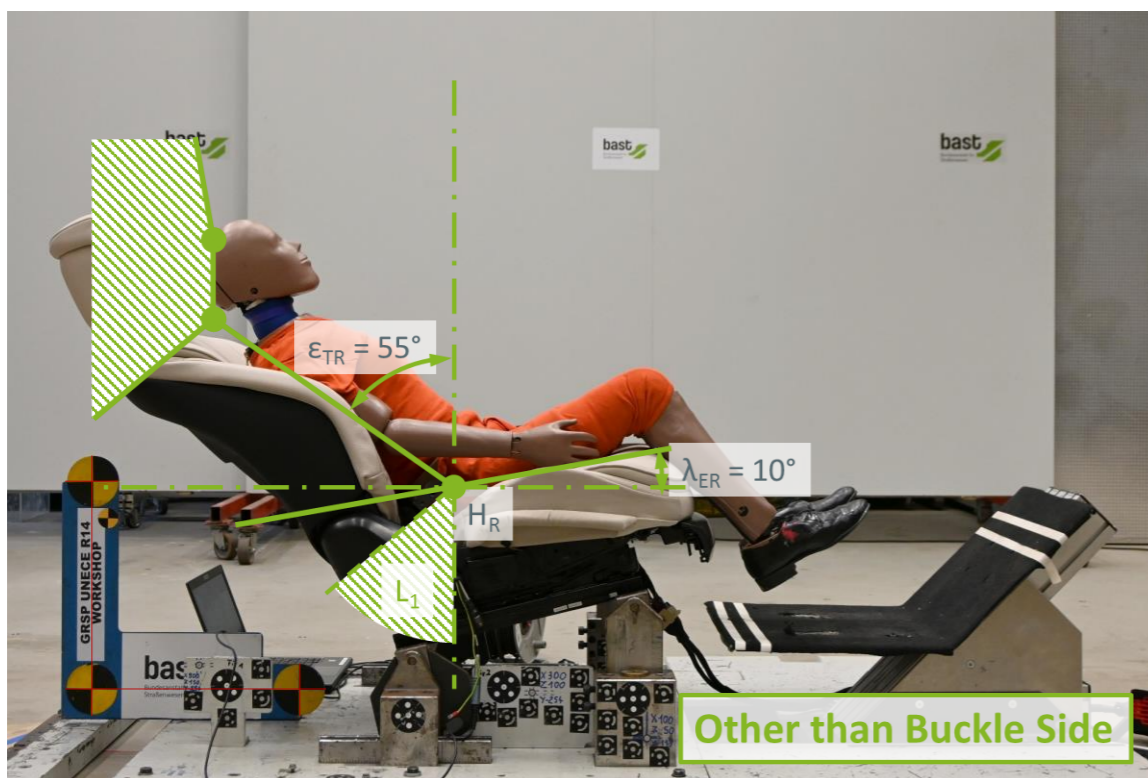
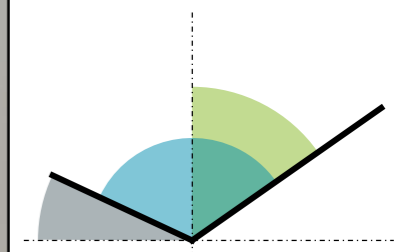

# Extended Use Position (25° // 55°)

- ▶ No continuous contact between the dummy's back and seatback

## Hybrid III 50<sup>th</sup> Male

Seat Cushion	25°
Backrest	55°
Opening Angle	120°

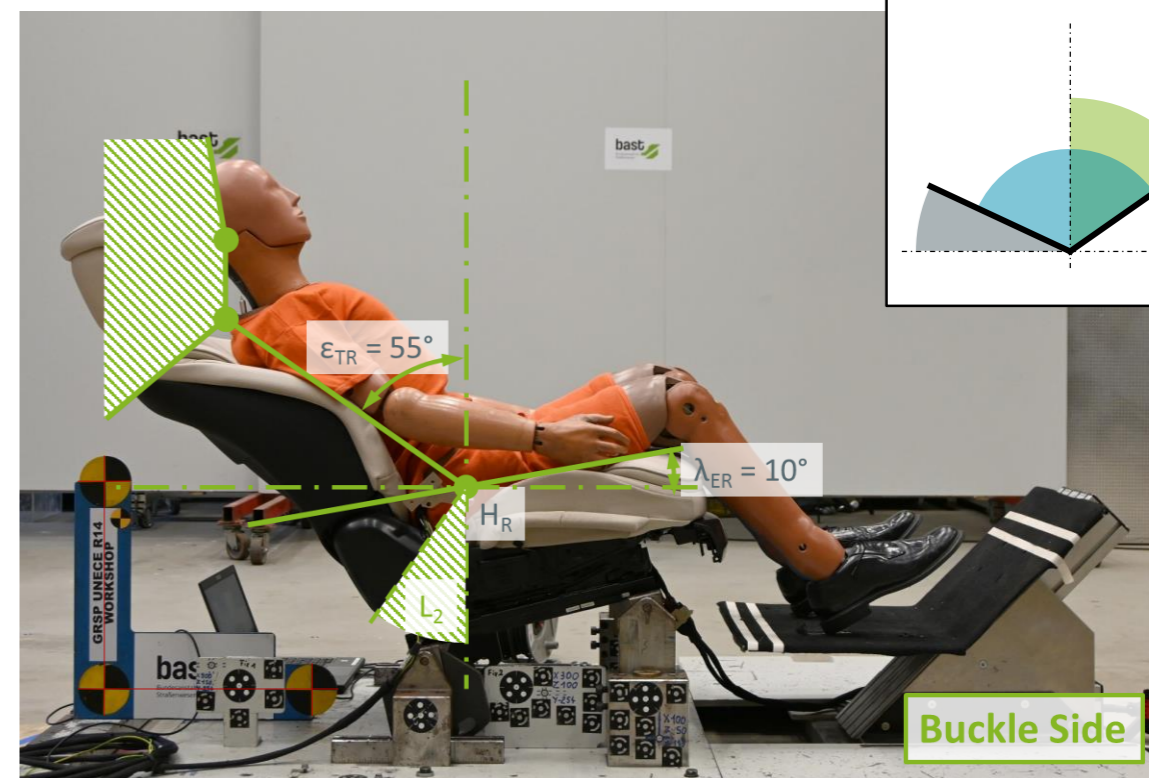
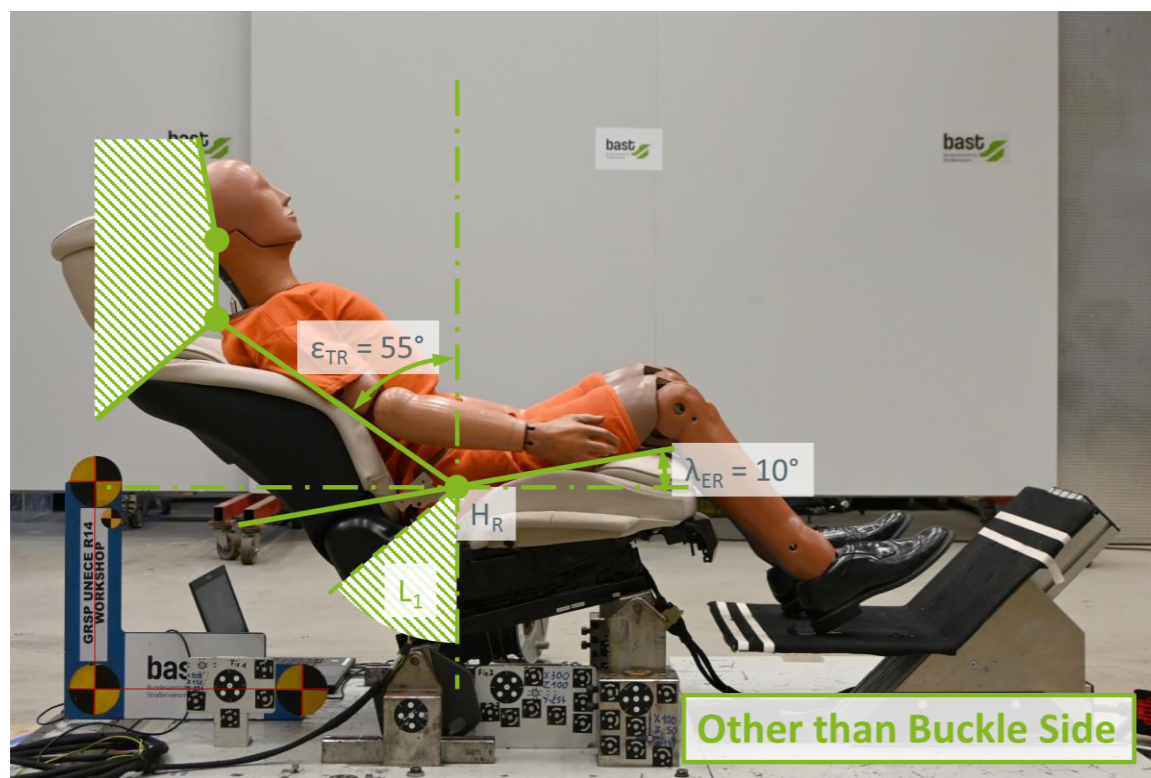
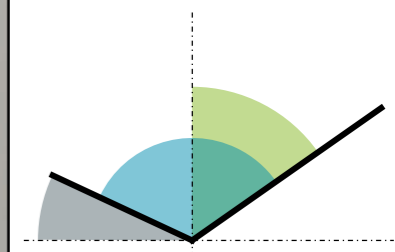

# Extended Use Position (25° // 55°)

- ▶ No continuous contact between the dummy's back and seatback

## Hybrid III 95<sup>th</sup> Male

Seat Cushion	25°
Backrest	55°
Opening Angle	120°

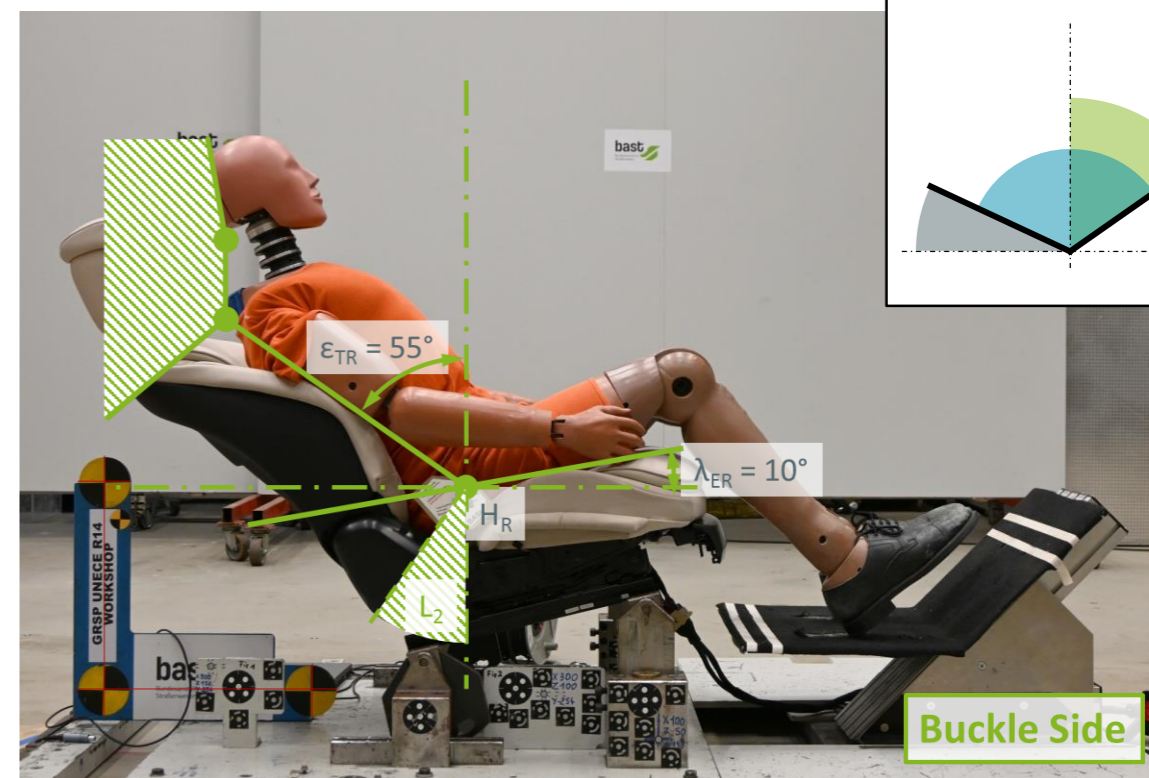
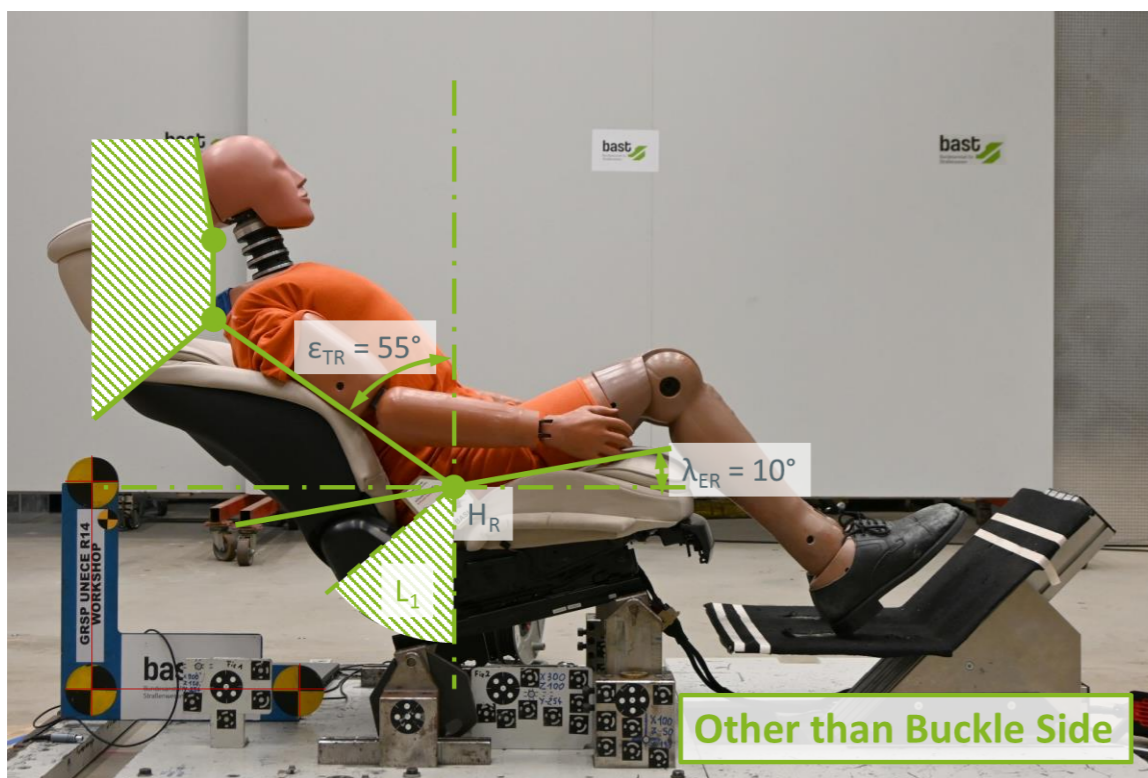
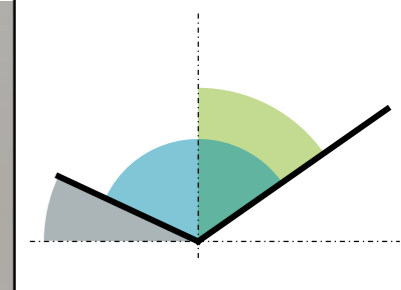

# Extended Use Position (25° // 55°)

- ▶ Continuous contact between the dummy's back and seatback
- ▶ Contact between pelvis and thigh flesh

## THOR-50M

Seat Cushion	25°
Backrest	55°
Opening Angle	120°

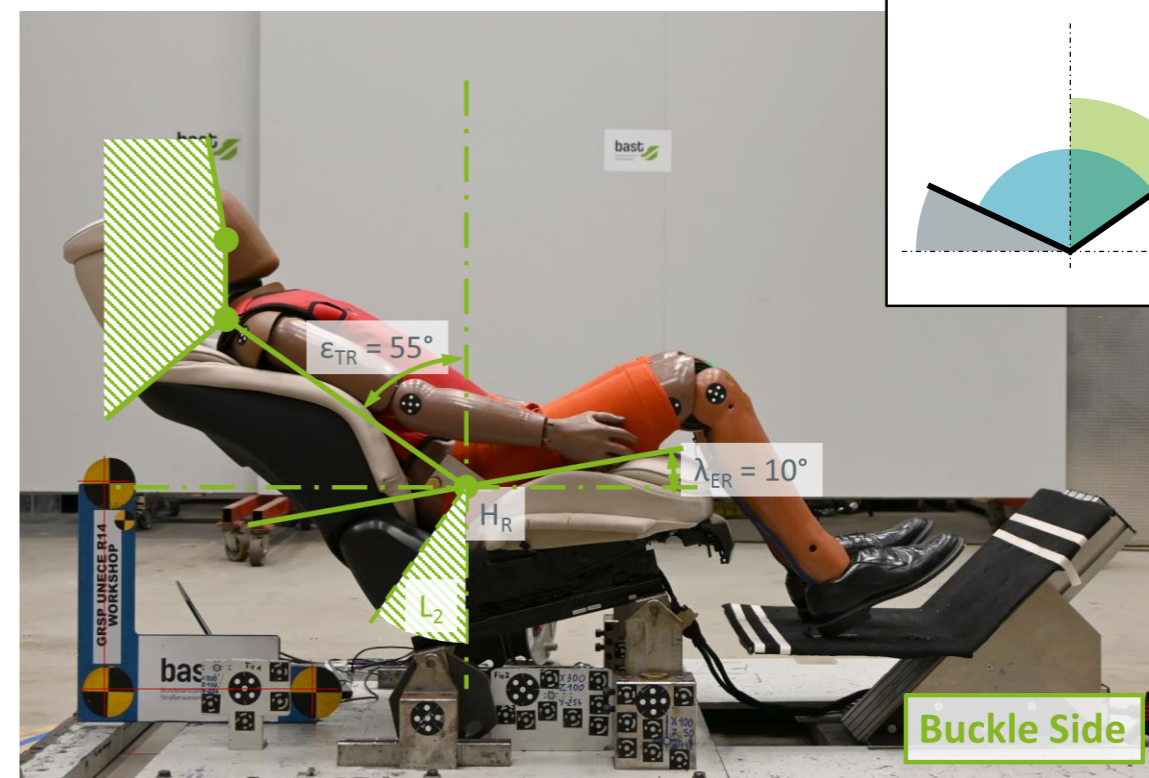
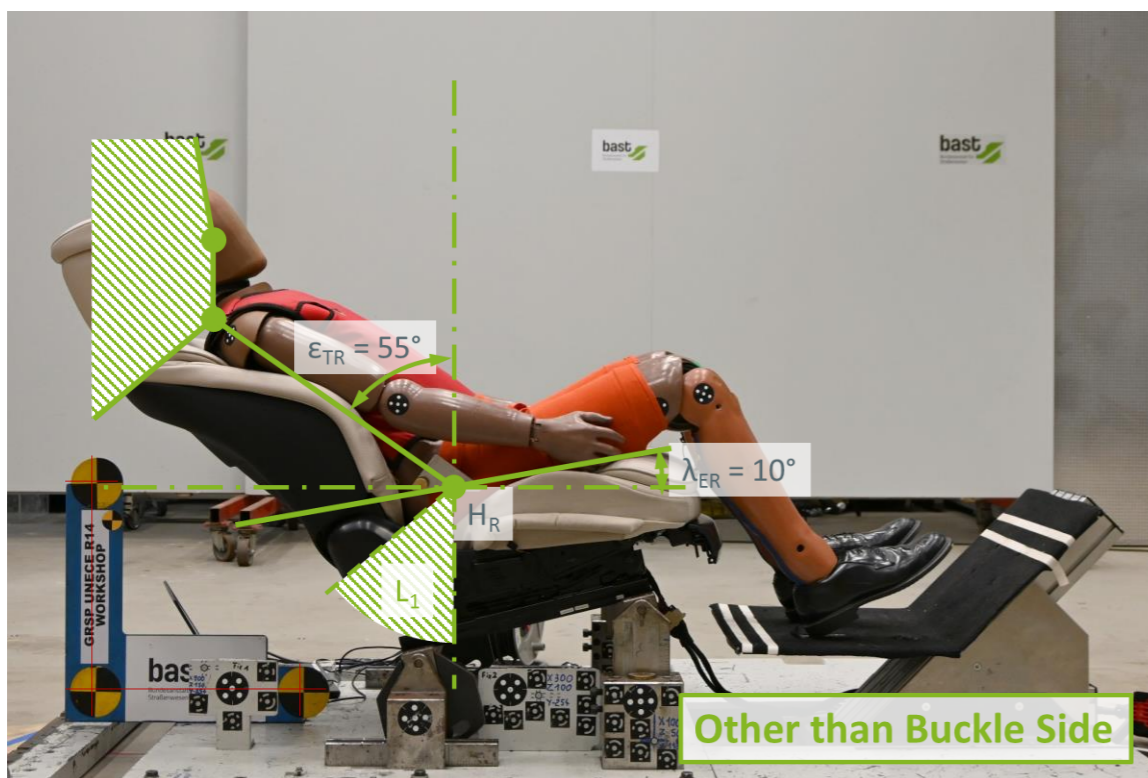
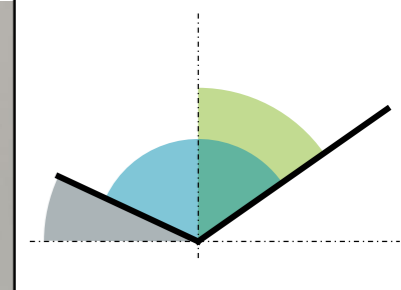

# Extended Use Position (25° // 55°)

- ▶ Continuous contact between the dummy's back and seatback
- ▶ No contact between pelvis and thigh flesh

## THOR-RS-50M

Seat Cushion	25°
Backrest	55°
Opening Angle	120°

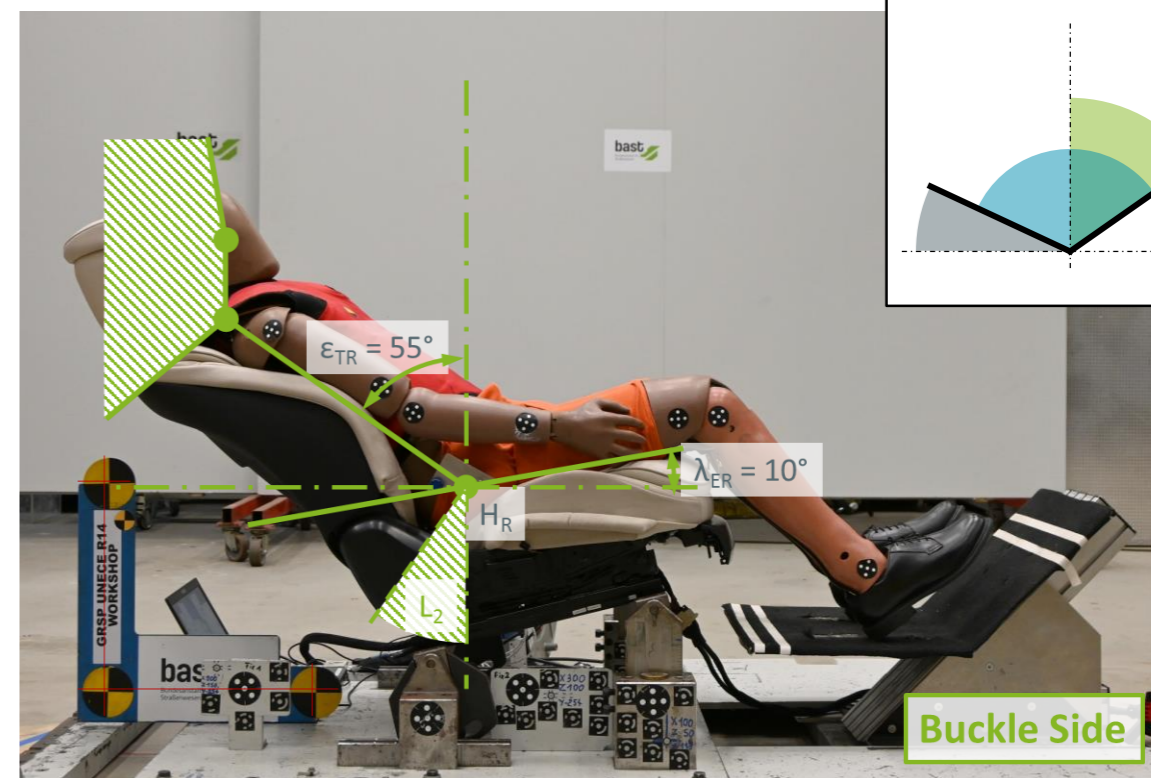
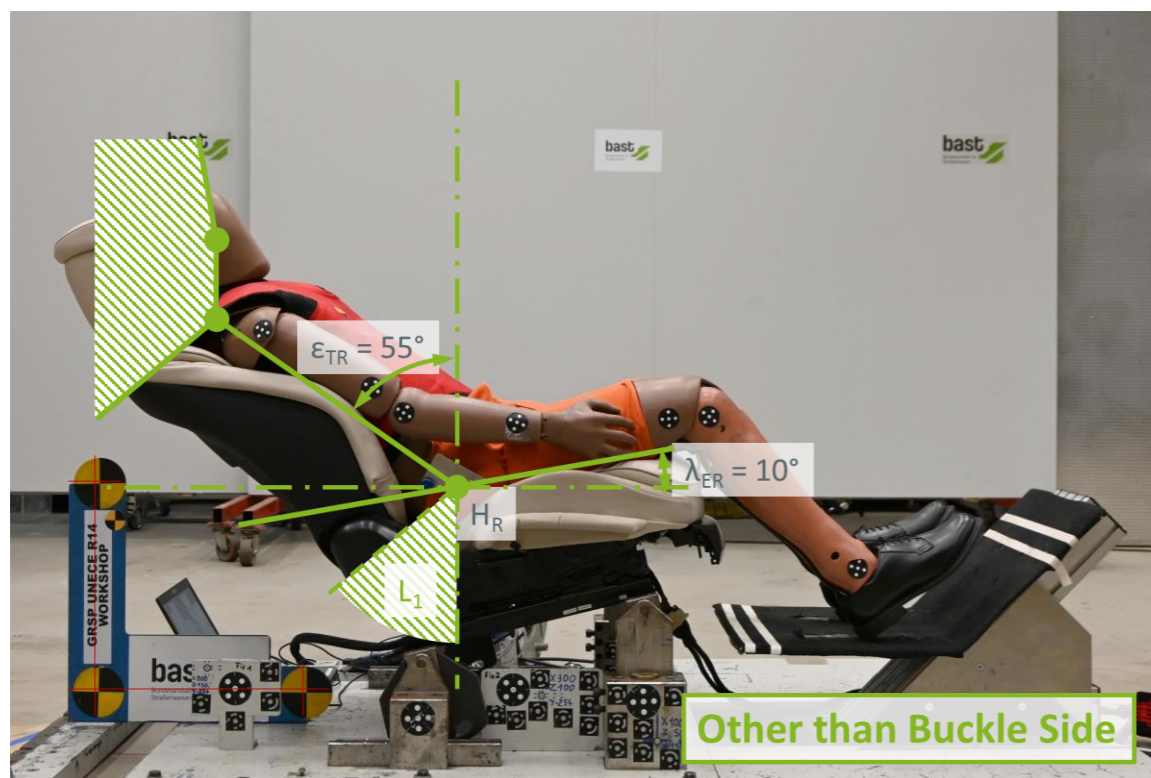
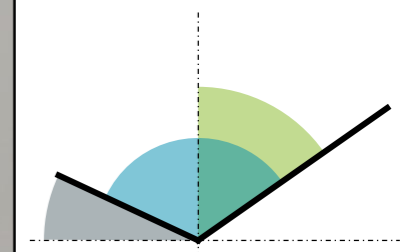

# Extended Use Position (25° // 55°)

**Male Participant**  
Height: 170 cm  
Seat Cushion 25°  
Backrest 55°  
Opening Angle 120°

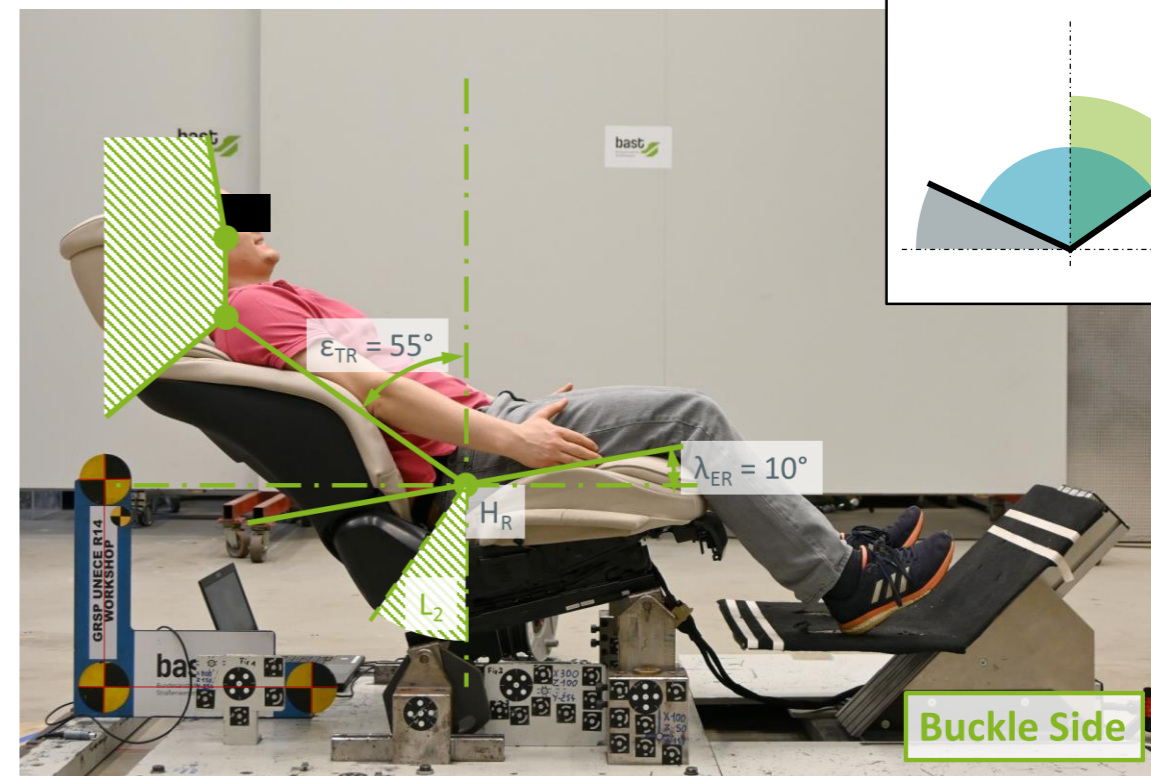
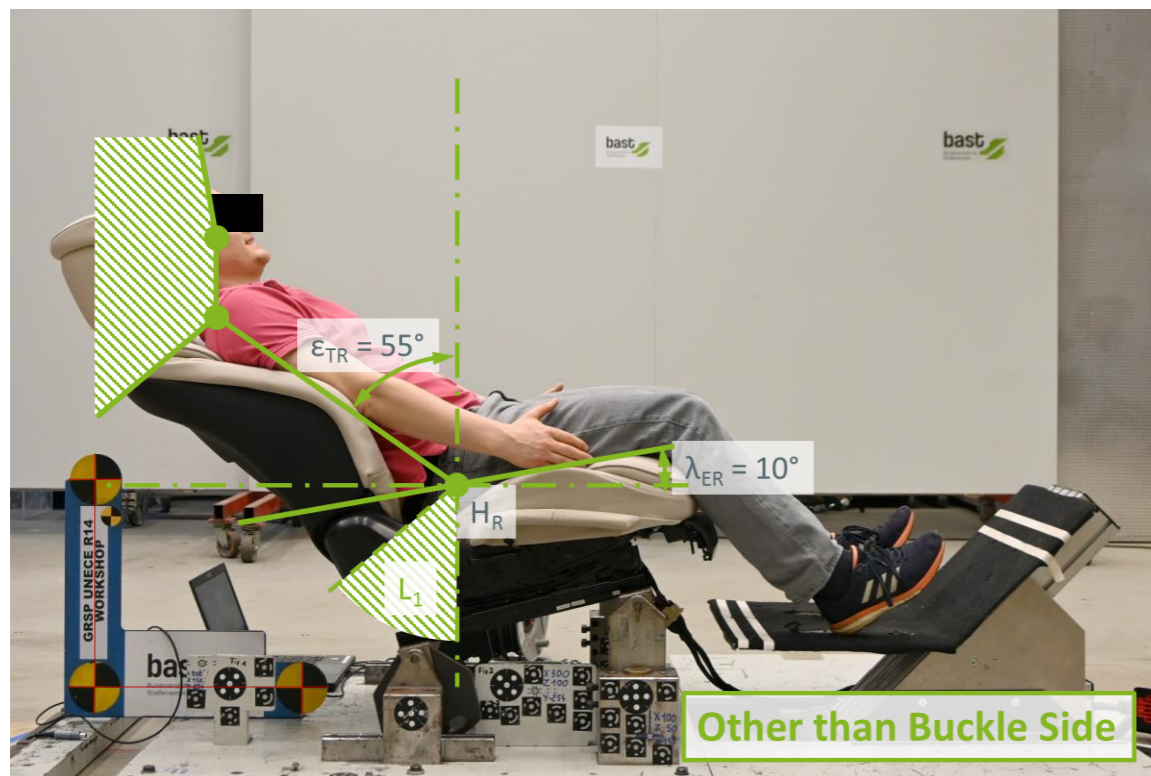
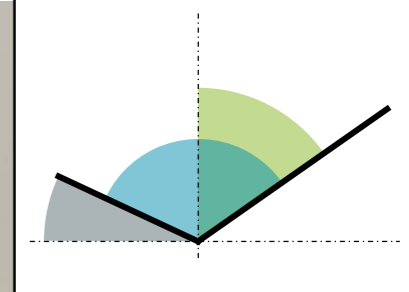



# Extended Use Position (25° // 55°)

**Male Participant**

Height: 193 cm

Seat Cushion 25°

Backrest 55°

Opening Angle 120°

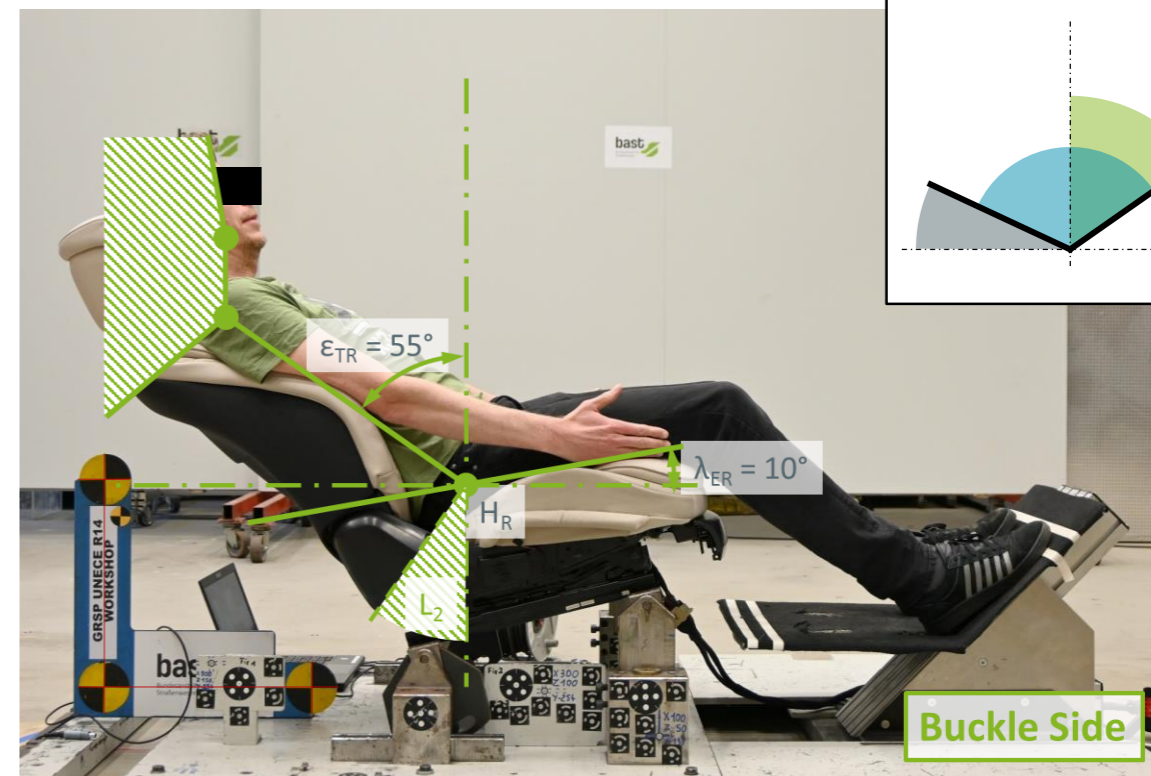
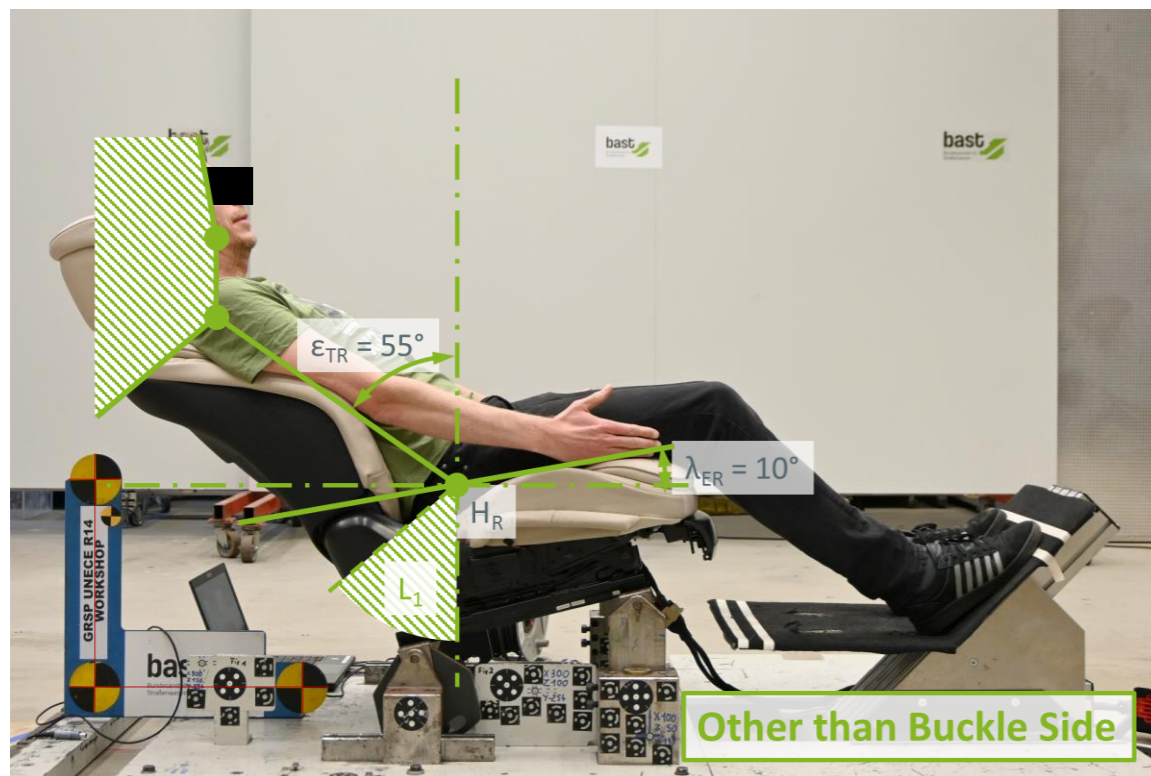
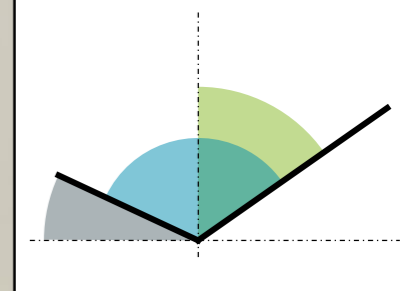

# Conclusion

- ▶ OICA's proposal to extend the R14 was positively received. Some adjustments remain to be discussed:
  - ▶ Proposed area might be too high for an optimal belt routing for small occupants  
→ Reduce  $A_{L1}$ ?
  - ▶ The proposal would allow  $L_1$  and  $L_2$  to be located in front of the  $H_R$ -point  
→ Some clarification needed (e.g. ' $L_1$  and  $L_2$  are not permitted to be in front of the  $H_R$ -point')
  - ▶ Inclination of  $E_R$ -plane changes accordingly to the change of the seat cushion inclination or by  $\frac{1}{3}$  of the change in seatback inclination from the normal use position.  
A combination of the two is not yet foreseen.
- ▶ For the Hybrid III family, no continuous contact between the ATD's back and backrest at an  $120^\circ$  opening angle was given.

Copyright 16.05.2024 Federal Highway Research Institute (BASt), all rights reserved.  
For reproduction permission and all other issues, please contact [schiessler@bast.de](mailto:schiessler@bast.de).



**Thank you!**

**I look forward to the joint  
discussion.**

**Matthias Schießler**

Section F2 – Passive Vehicle Safety, Biomechanics

 (+49) 2204 43-5209

 [schiessler@bast.de](mailto:schiessler@bast.de)

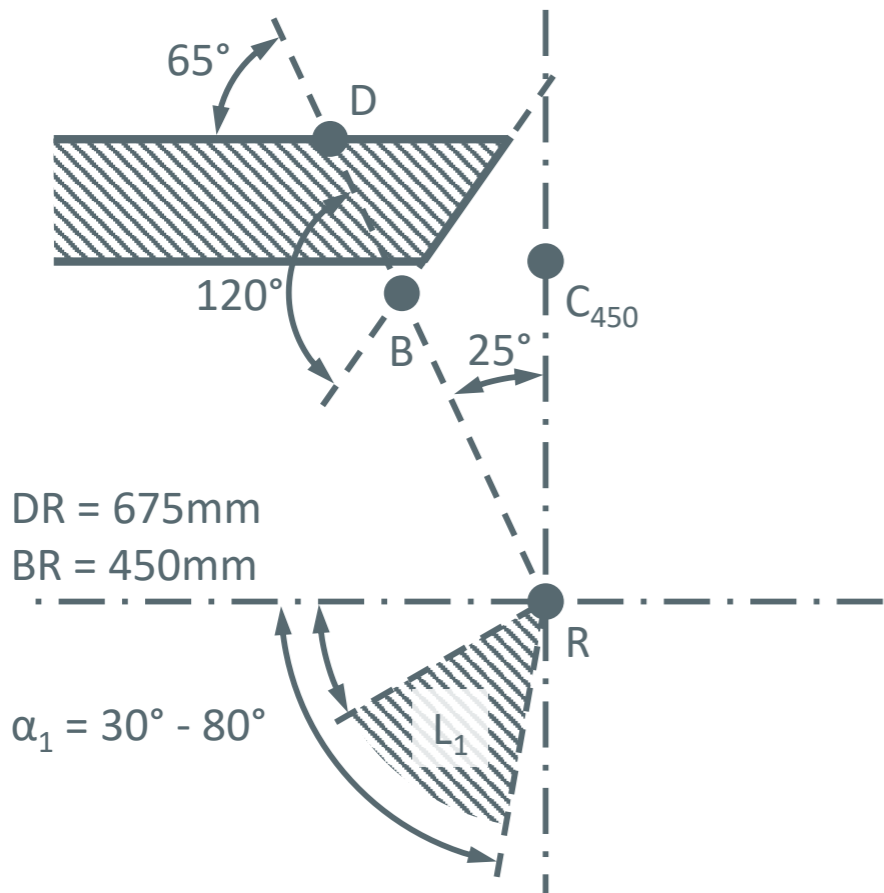

Other than Buckle Side

**Configuration No. 1**

- Seat Cushion 15°
- Backrest 25°
- Opening Angle 100°

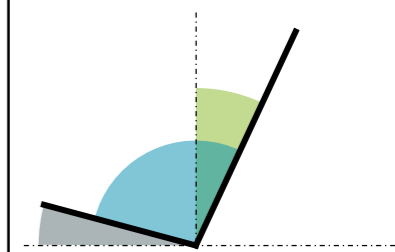

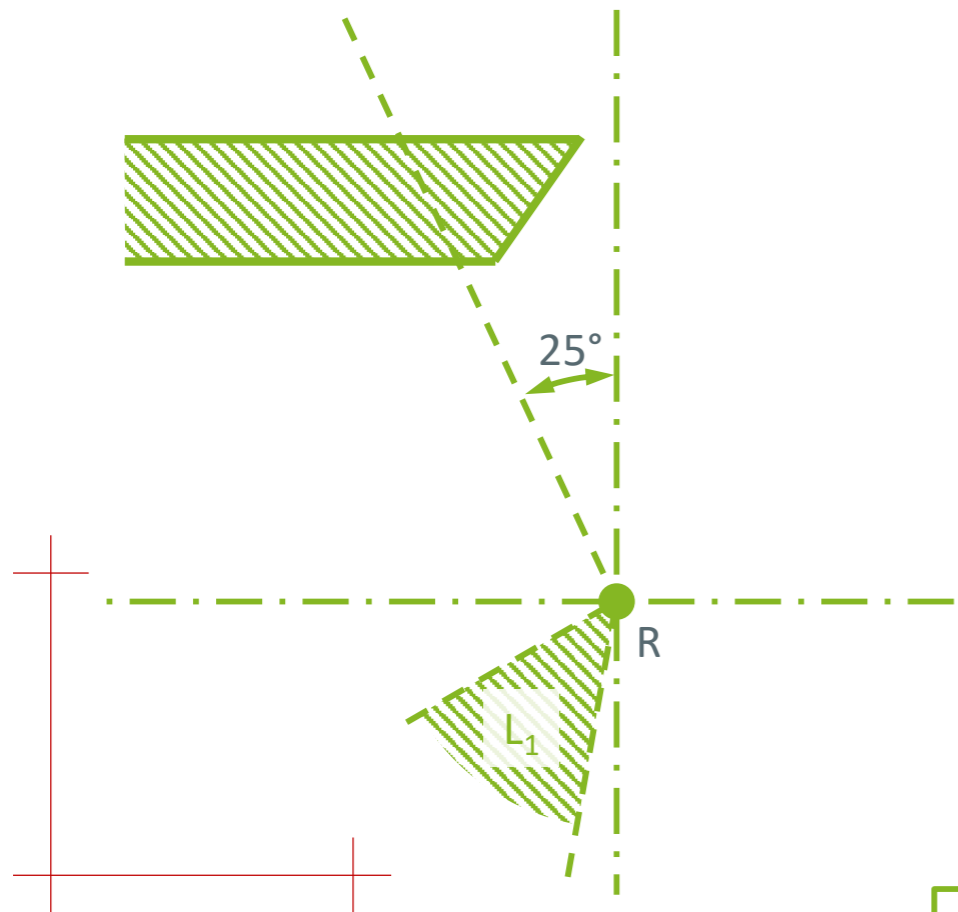

Other than Buckle Side

**Configuration No. 1**

Seat Cushion	15°
Backrest	25°
Opening Angle	100°

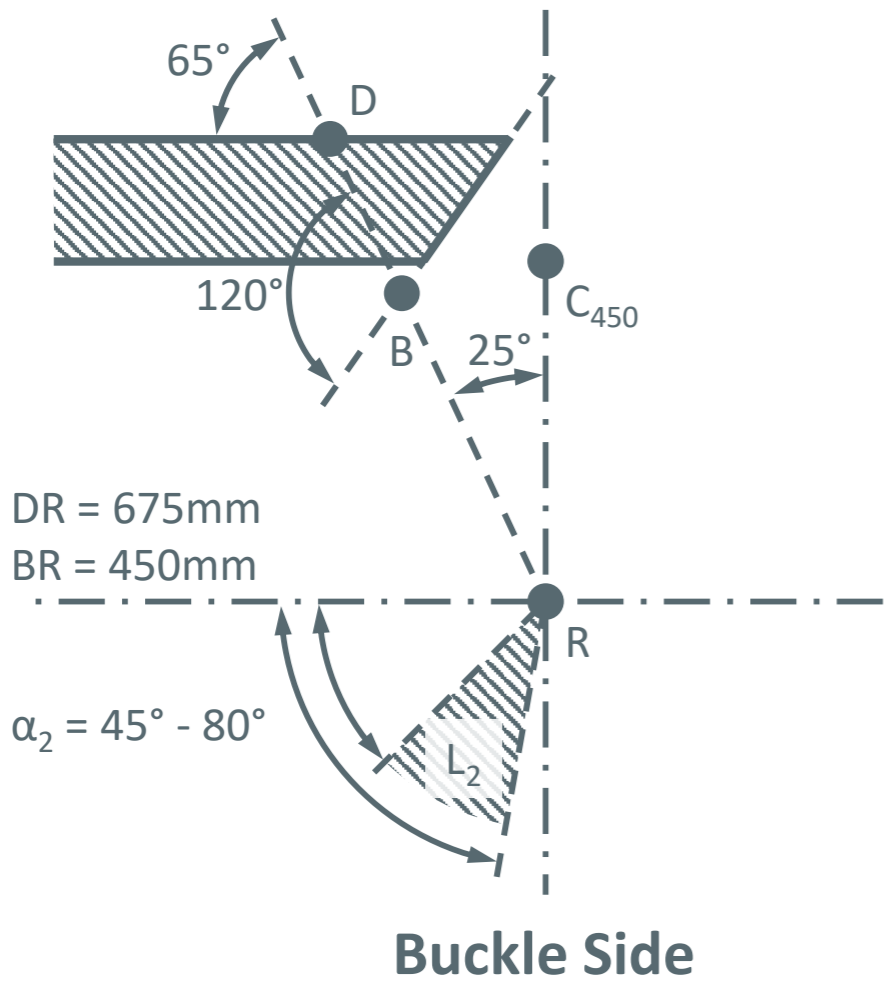

**Configuration No. 1**

Seat Cushion	15°
Backrest	25°
Opening Angle	100°

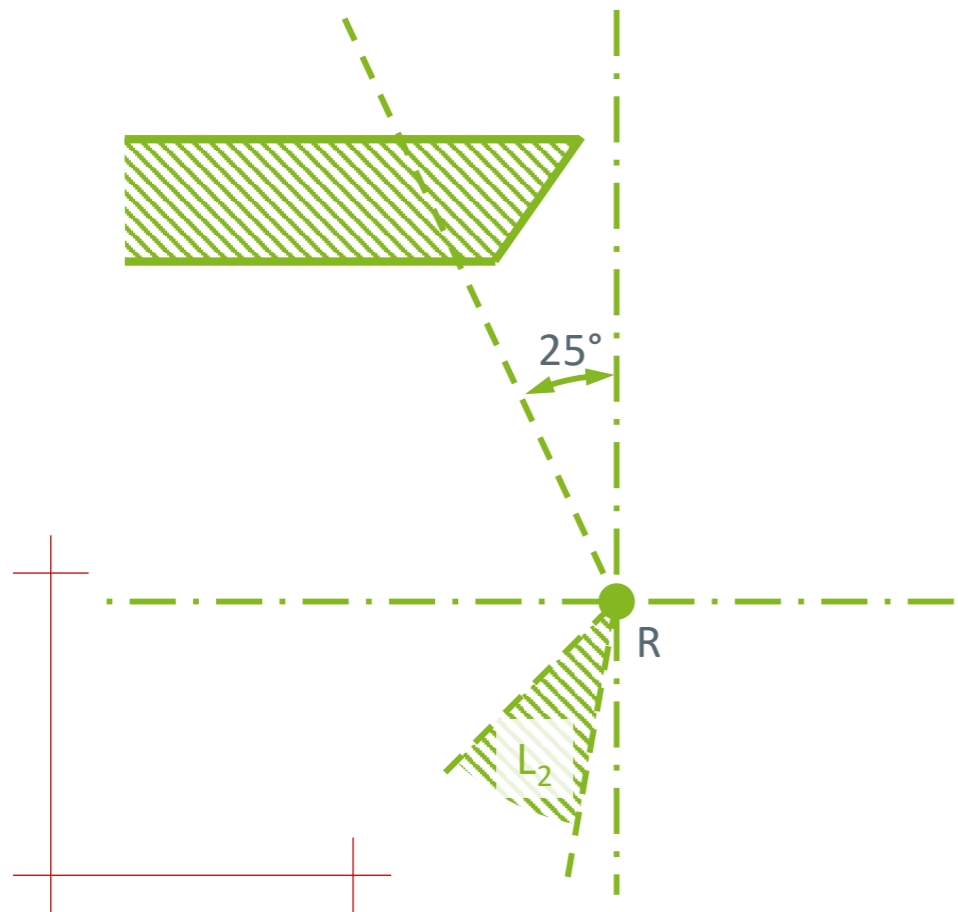

**Buckle Side**

**Configuration No. 1**

Seat Cushion	15°
Backrest	25°
Opening Angle	100°

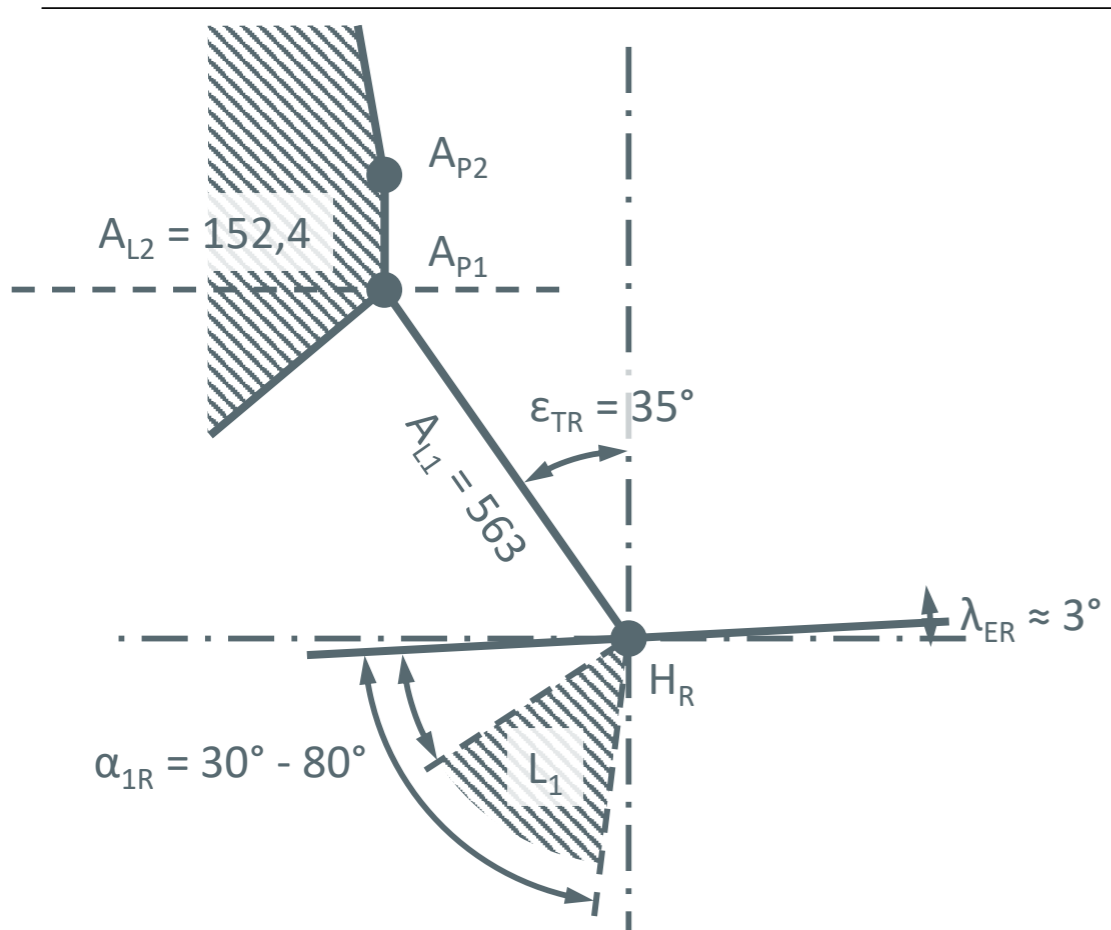

Other than Buckle Side

**Configuration No. 2**

Seat Cushion	15°
Backrest	35°
Opening Angle	110°



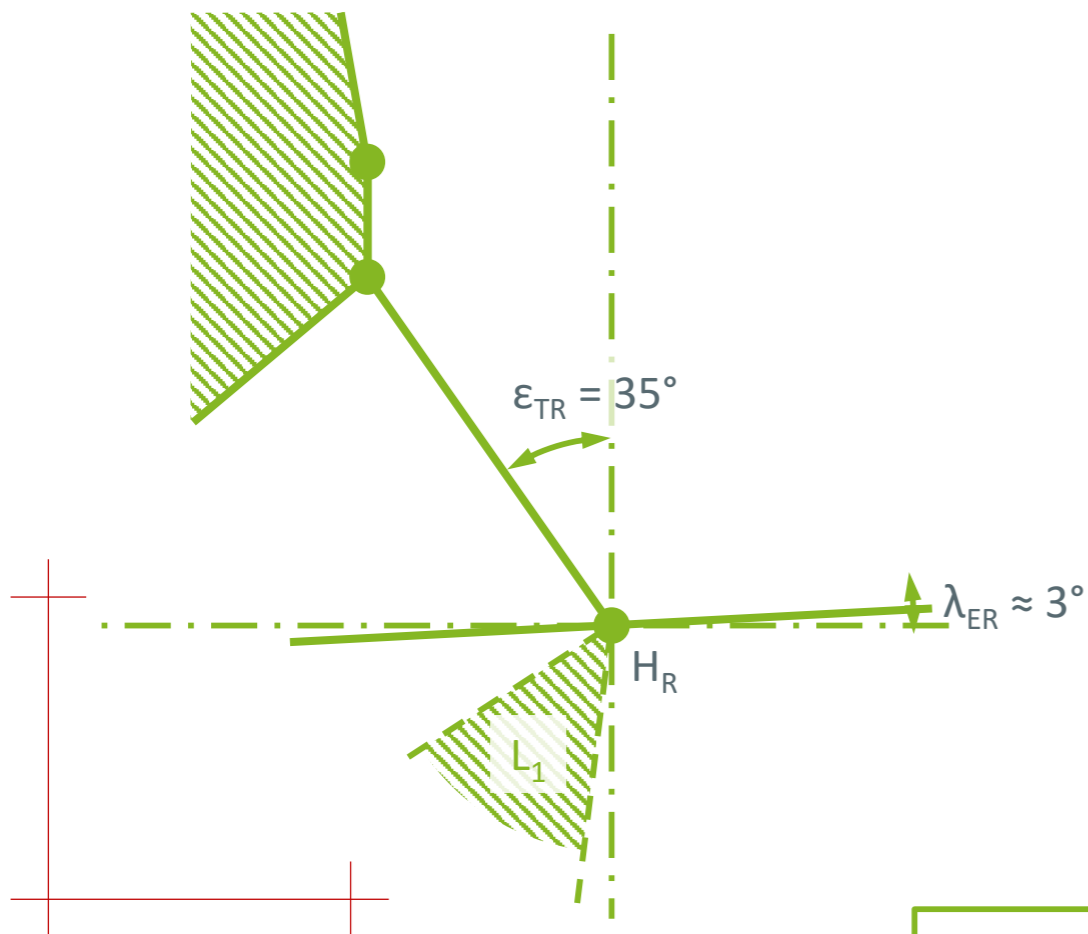

Other than Buckle Side

**Configuration No. 2**

Seat Cushion	15°
Backrest	35°
Opening Angle	110°

The small diagram shows a seat with a backrest tilted at 35° and a seat cushion tilted at 15° relative to a horizontal dashed line. The opening angle between the backrest and the seat cushion is 110°.

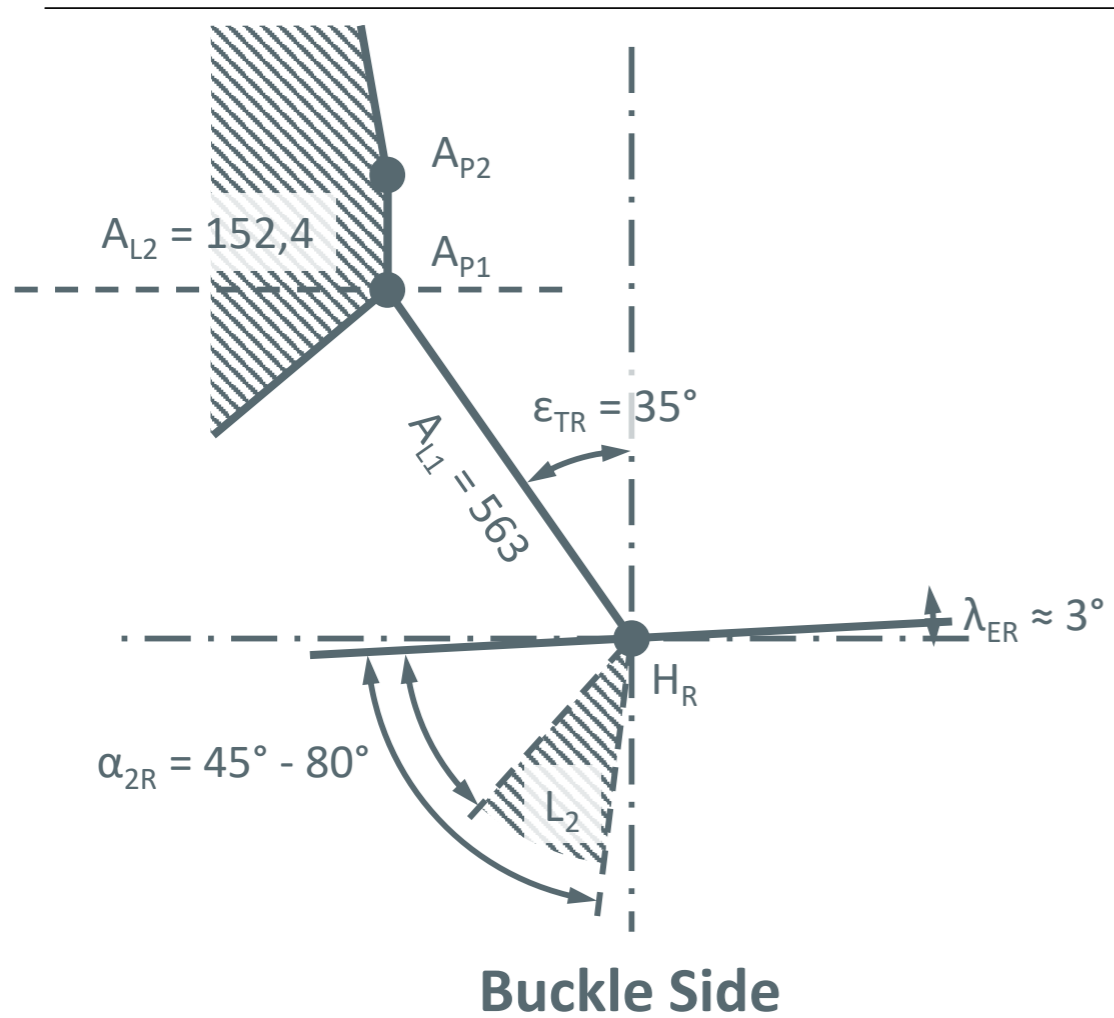

**Configuration No. 2**

Seat Cushion  $15^\circ$

Backrest  $35^\circ$

Opening Angle  $110^\circ$

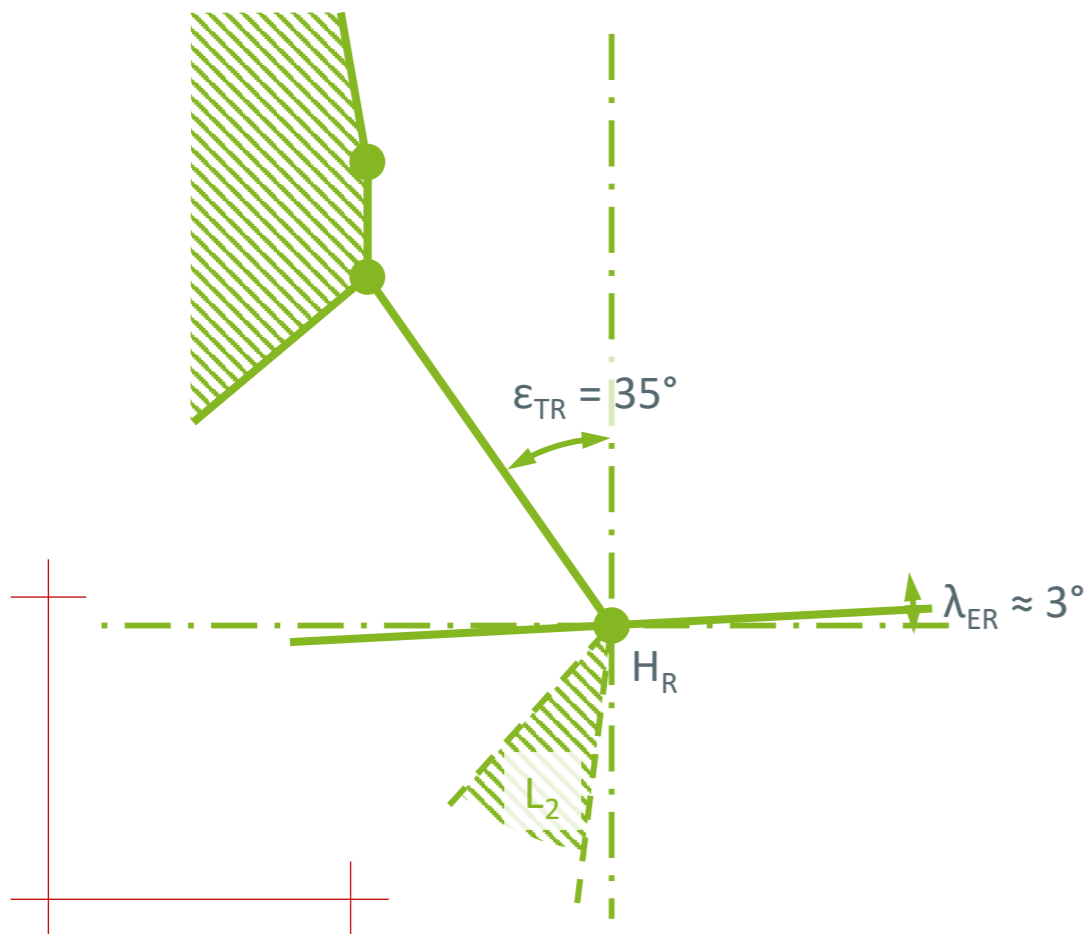

**Buckle Side**

**Configuration No. 2**

Seat Cushion	15°
Backrest	35°
Opening Angle	110°

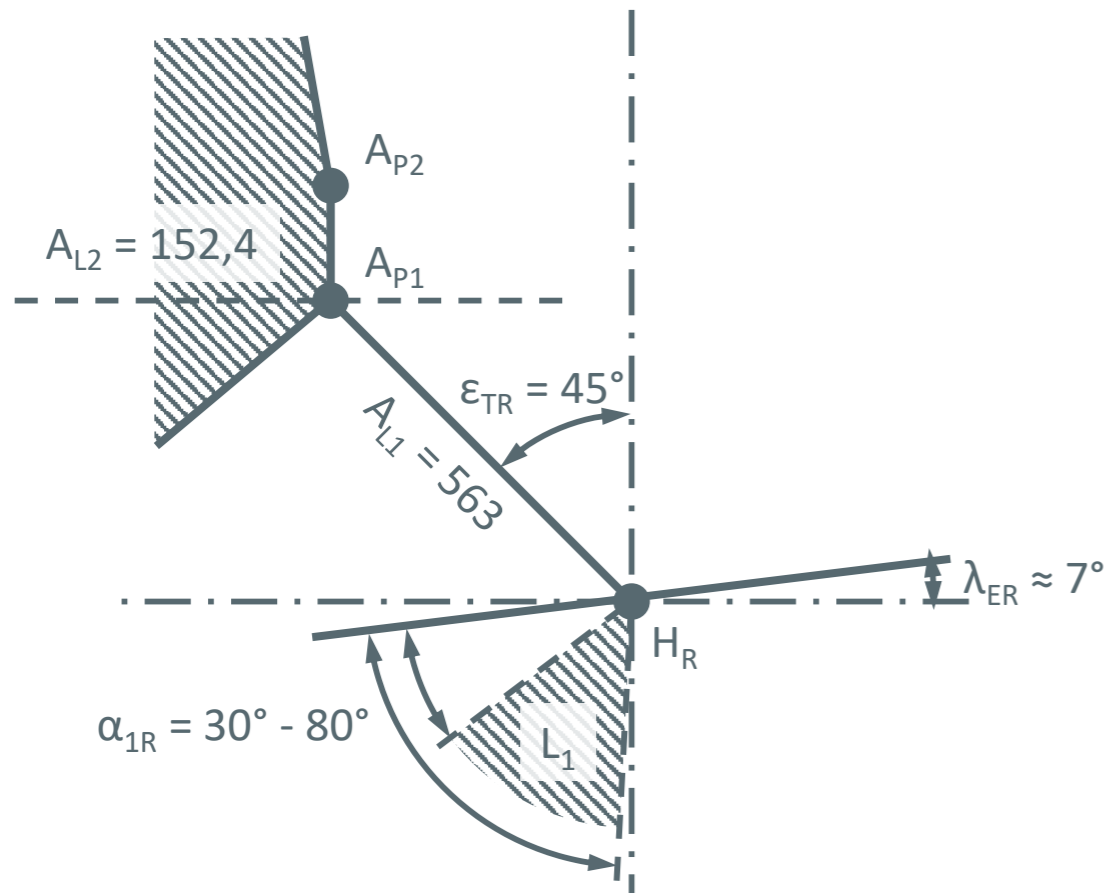

Other than Buckle Side

**Configuration No. 3**

- Seat Cushion 15°
- Backrest 45°
- Opening Angle 120°

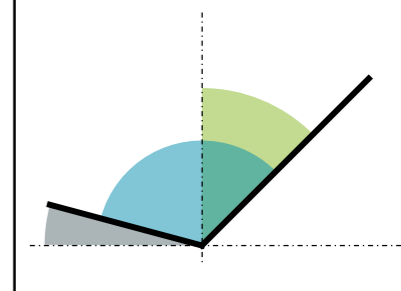

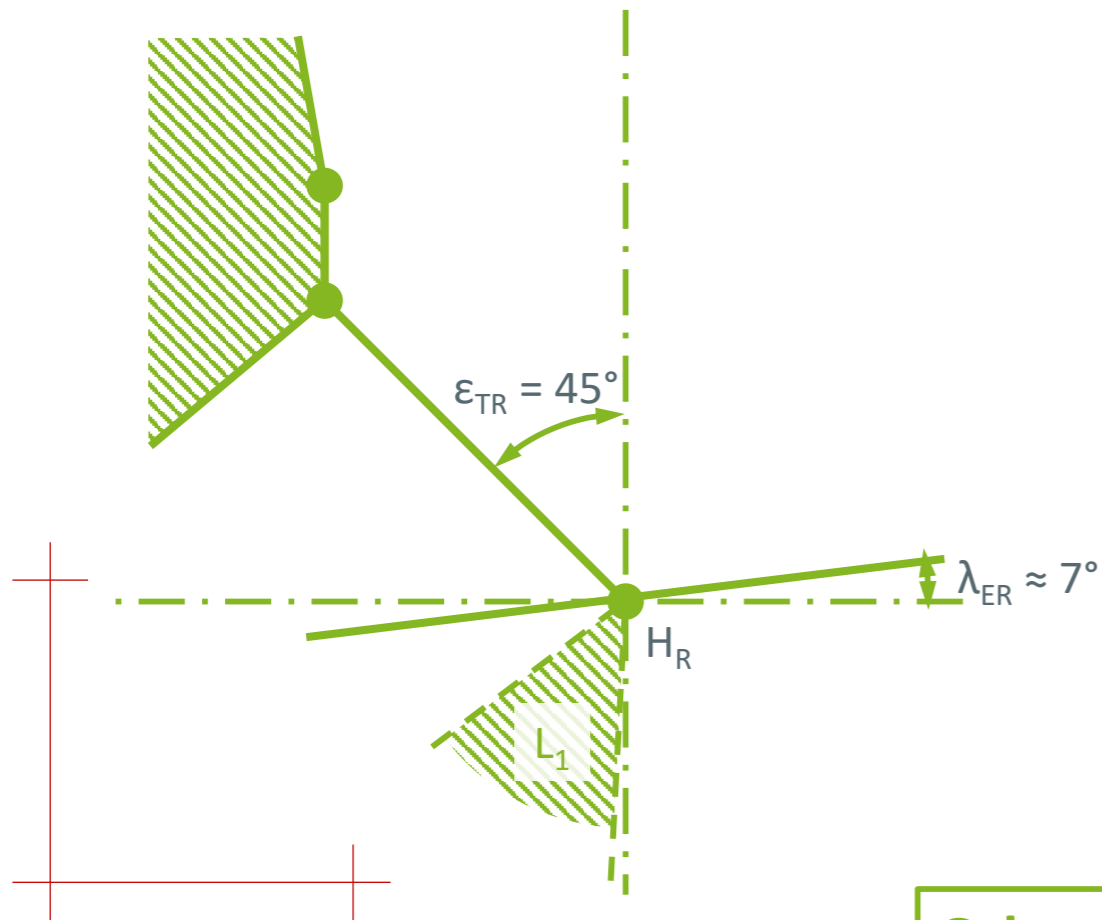

Other than Buckle Side

**Configuration No. 3**

- Seat Cushion  $15^\circ$
- Backrest  $45^\circ$
- Opening Angle  $120^\circ$

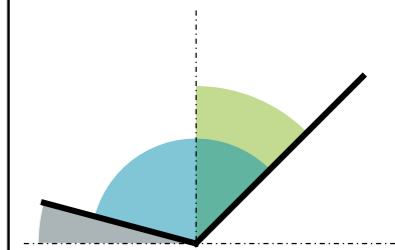

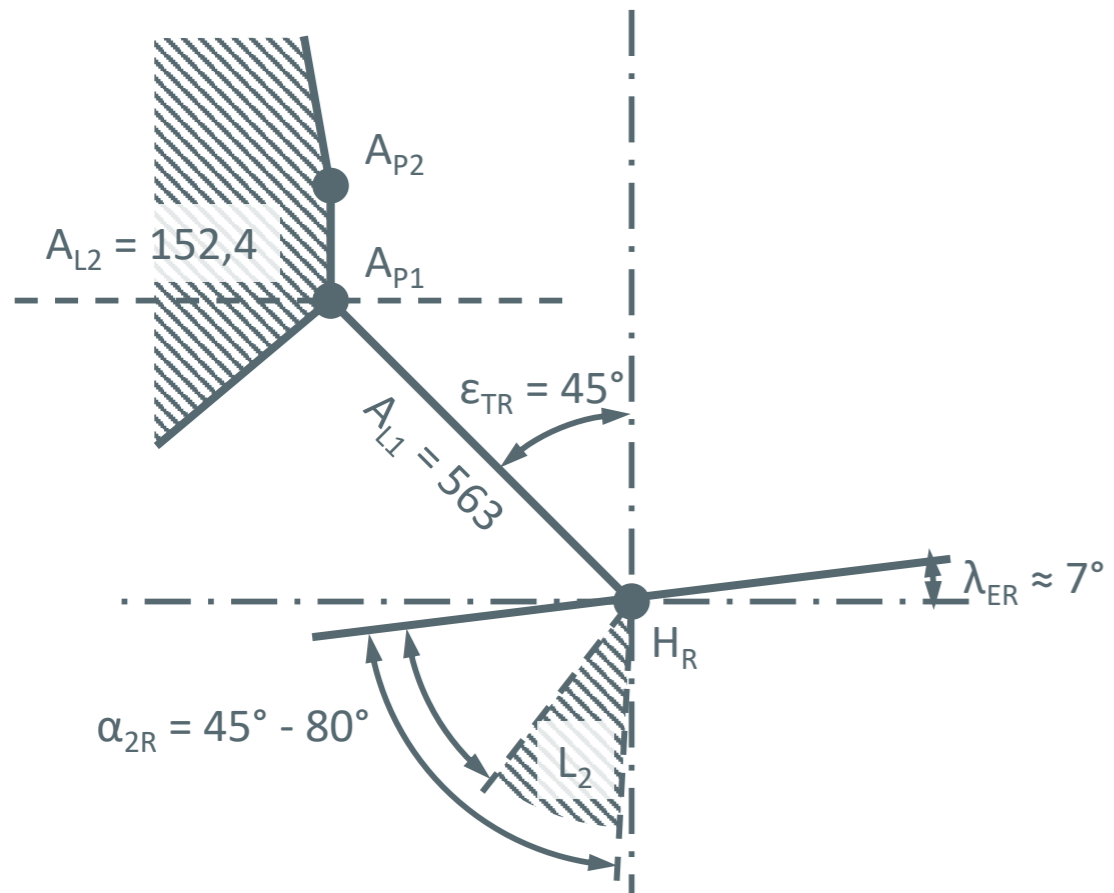

**Buckle Side**

**Configuration No. 3**

Seat Cushion	15°
Backrest	45°
Opening Angle	120°

Small diagram of the seat configuration with colored sectors: a blue sector for the seat cushion, a green sector for the backrest, and a grey sector for the opening angle.

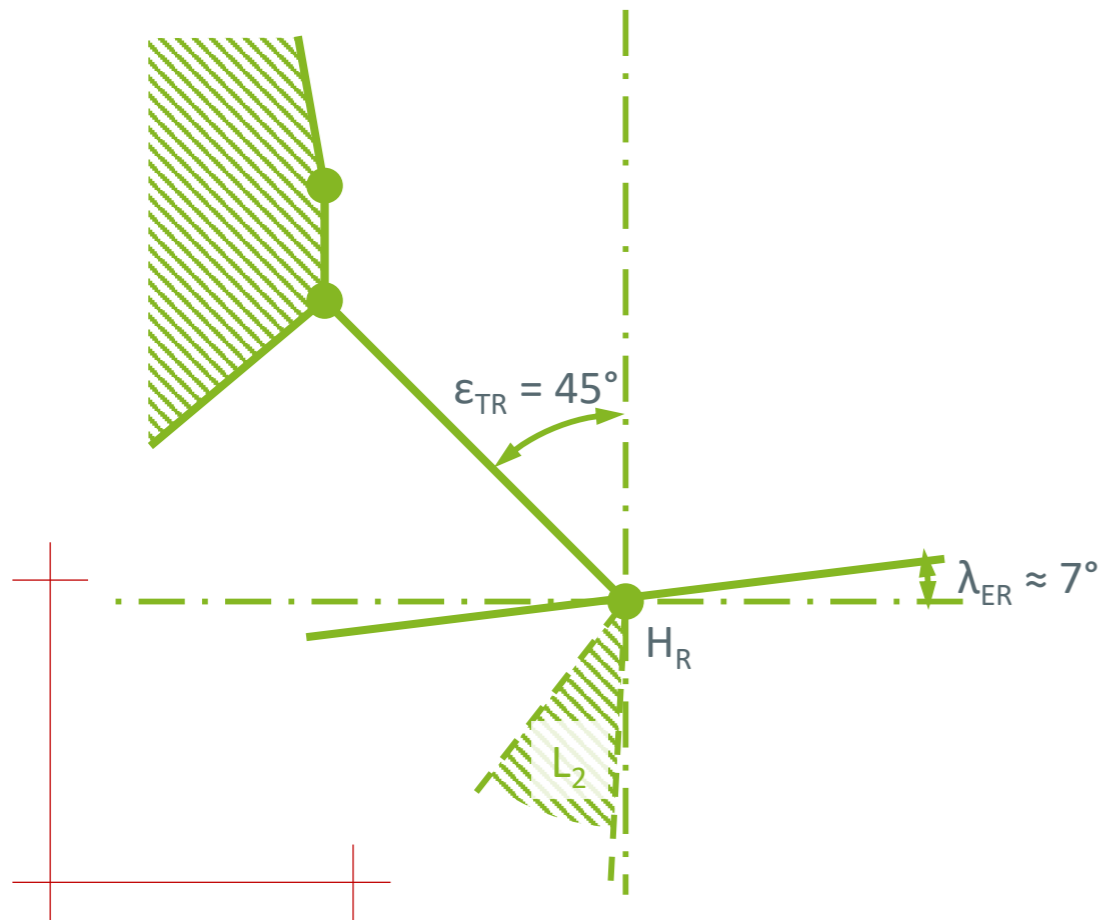

**Buckle Side**

**Configuration No. 3**

Seat Cushion	15°
Backrest	45°
Opening Angle	120°

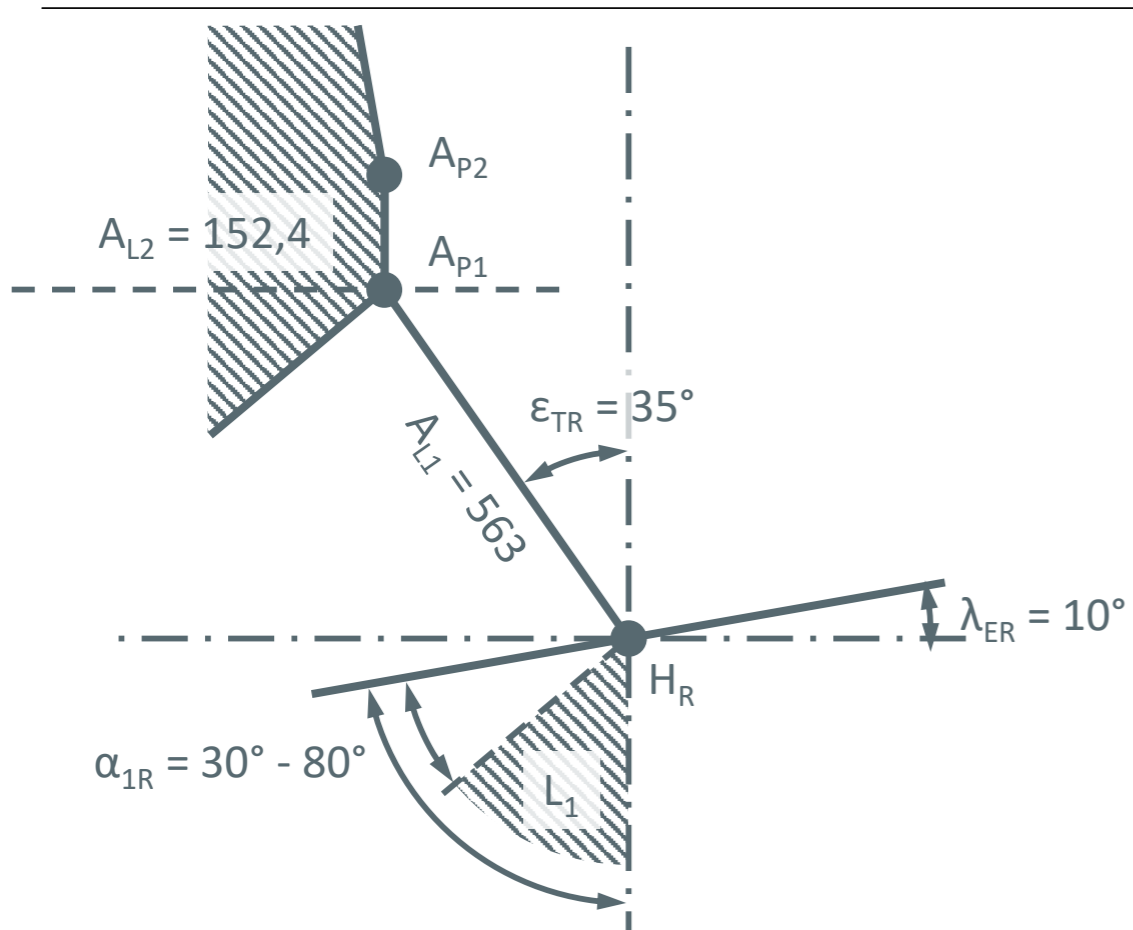

Other than Buckle Side

**Configuration No. 4**

Seat Cushion	25°
Backrest	35°
Opening Angle	100°



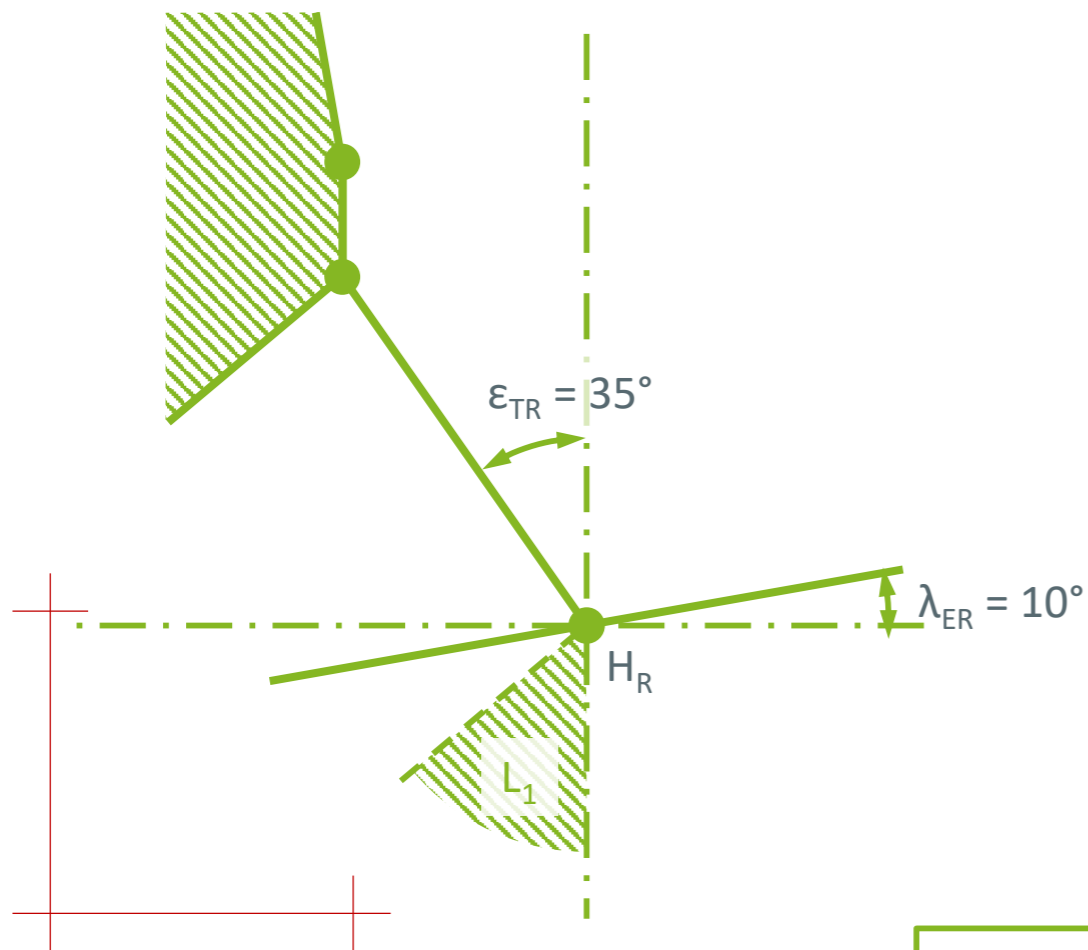

Other than Buckle Side

**Configuration No. 4**

Seat Cushion	25°
Backrest	35°
Opening Angle	100°

A simplified diagram of Configuration No. 4 showing the seat cushion, backrest, and opening angle. The seat cushion is shaded blue, the backrest is shaded green, and the opening angle is shaded grey.

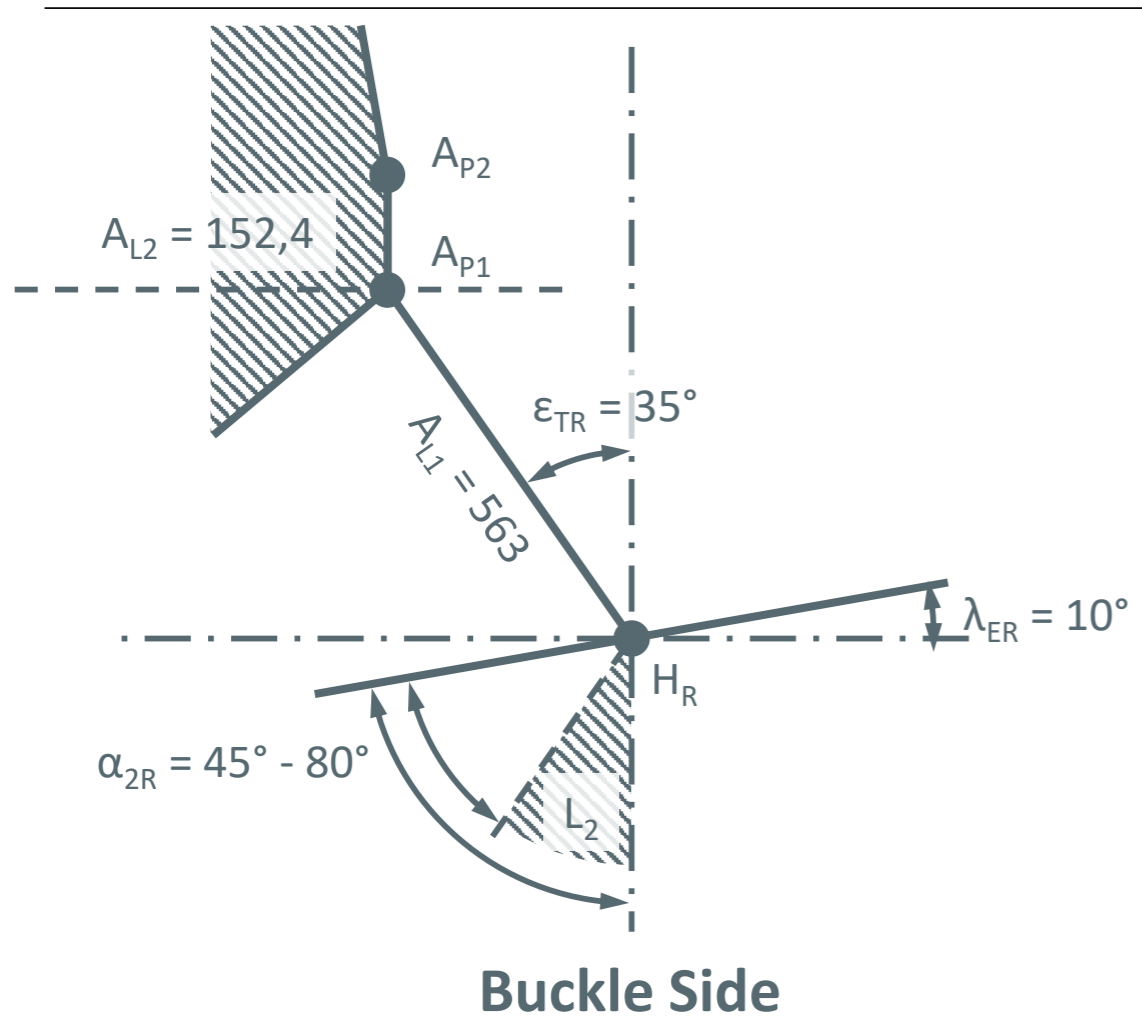

**Configuration No. 4**

Seat Cushion	25°
Backrest	35°
Opening Angle	100°

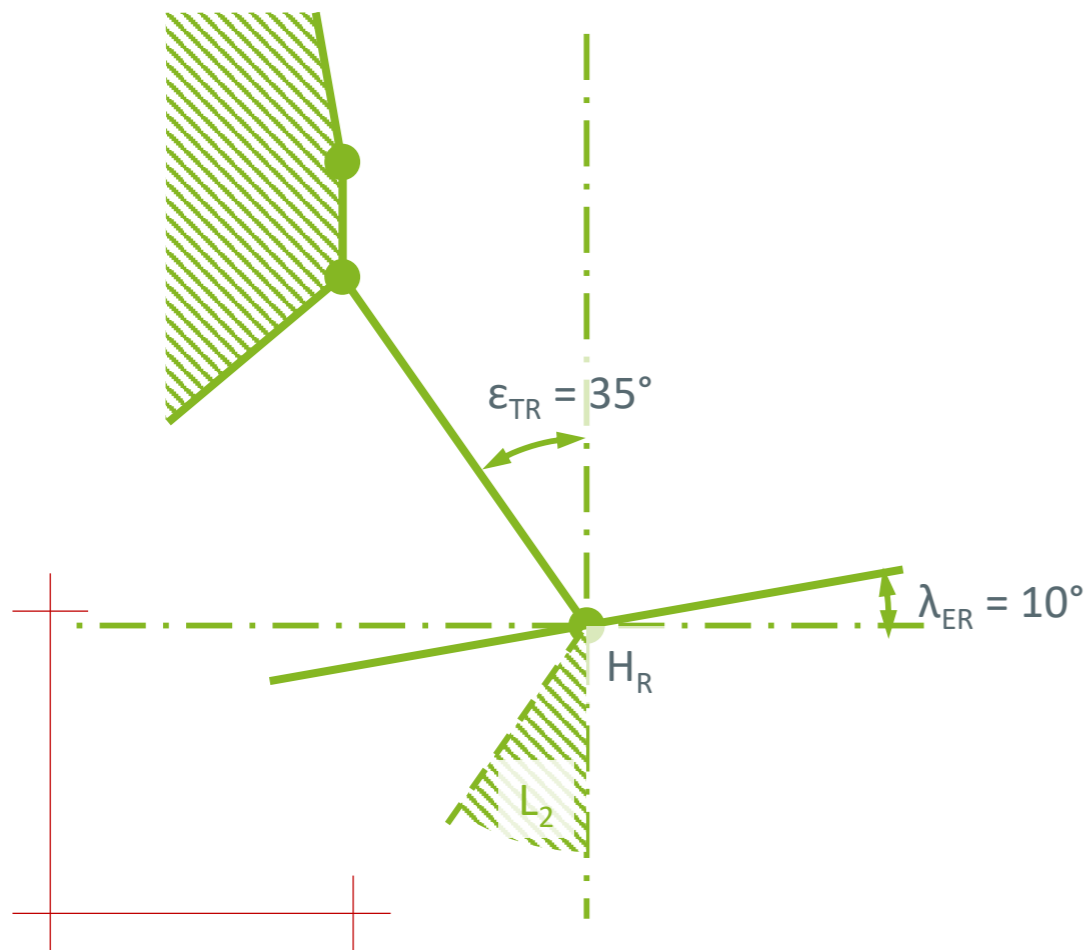

**Buckle Side**

**Configuration No. 4**

Seat Cushion	25°
Backrest	35°
Opening Angle	100°

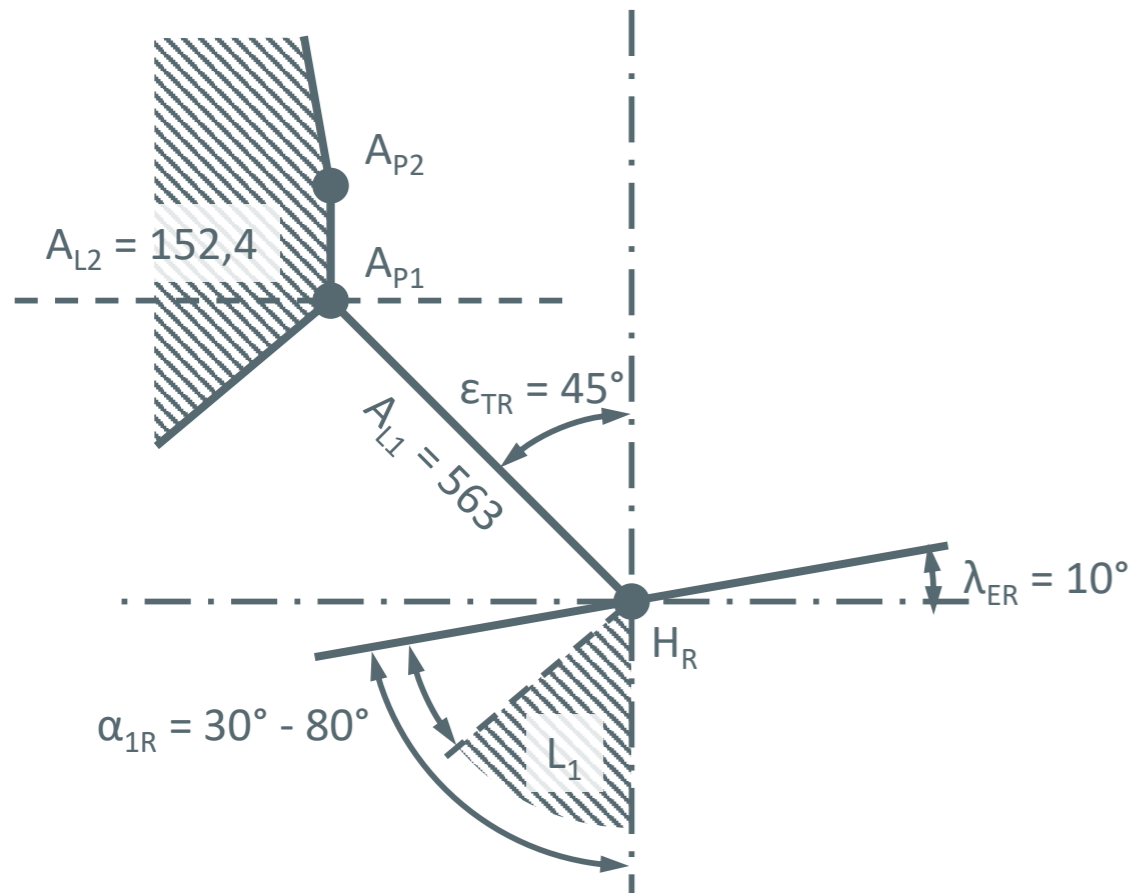

Other than Buckle Side

**Configuration No. 5**

Seat Cushion	25°
Backrest	45°
Opening Angle	110°

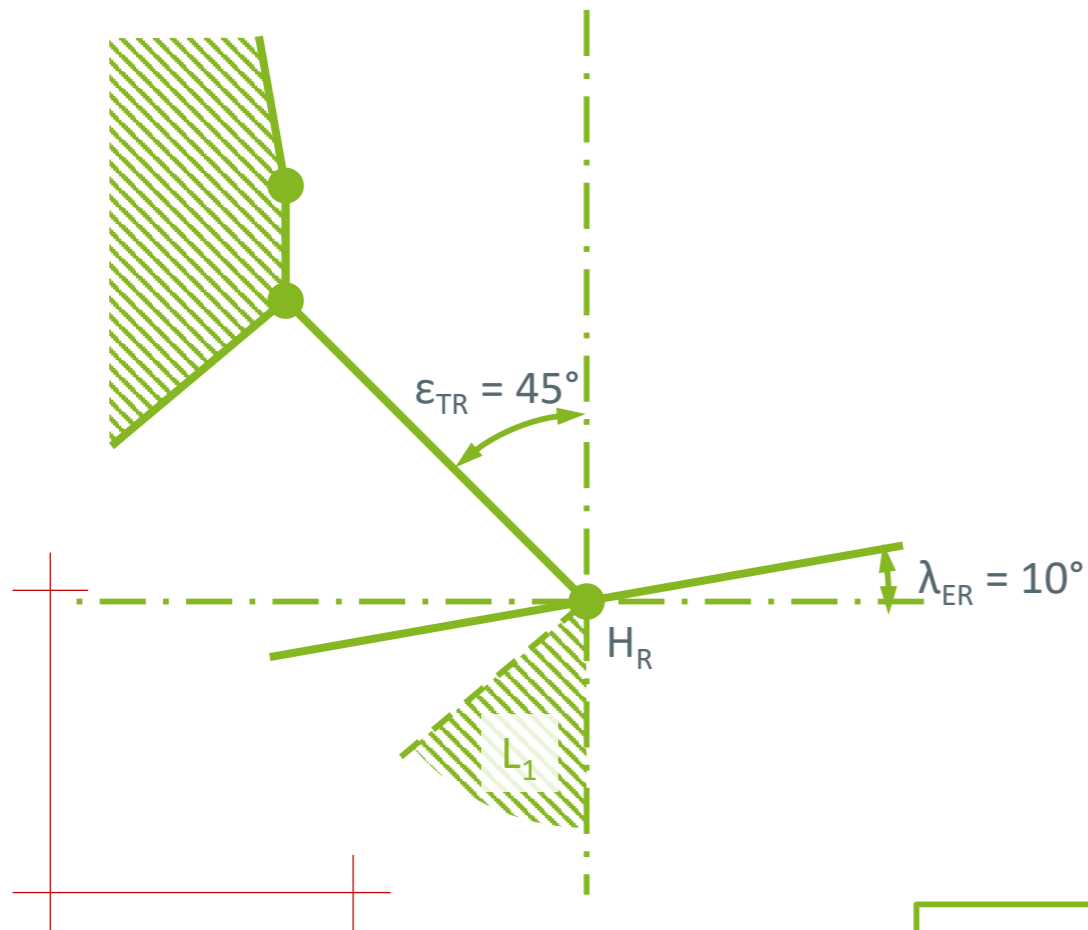

Other than Buckle Side

**Configuration No. 5**

Seat Cushion	25°
Backrest	45°
Opening Angle	110°

The small diagram shows a seat backrest and seat cushion with colored sectors representing the angles: 25° for the seat cushion, 45° for the backrest, and a total opening angle of 110°.

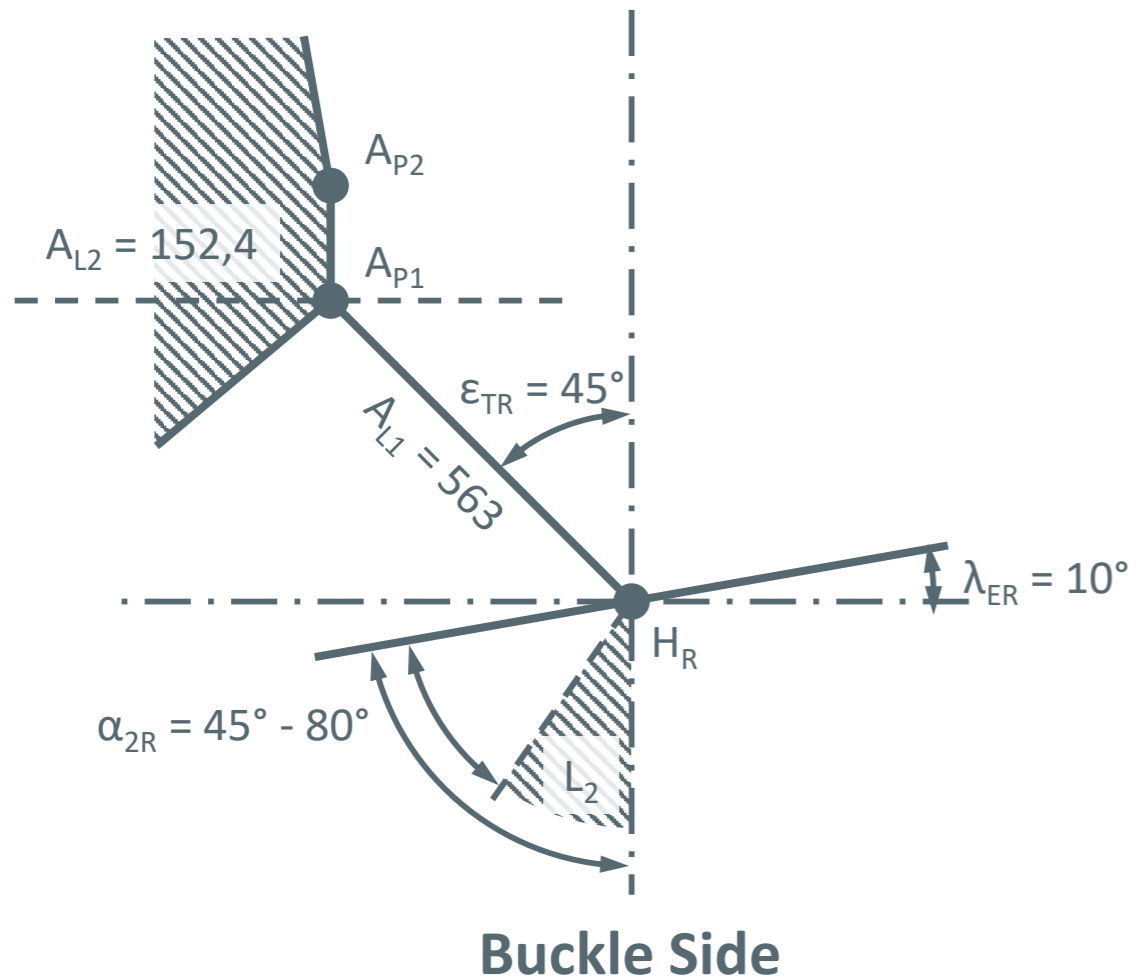

**Configuration No. 5**

- Seat Cushion  $25^\circ$
- Backrest  $45^\circ$
- Opening Angle  $110^\circ$

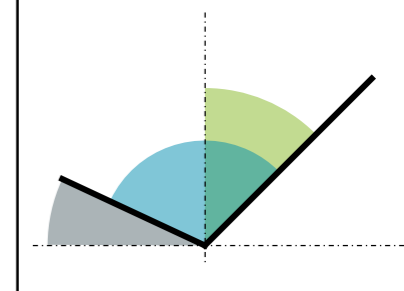

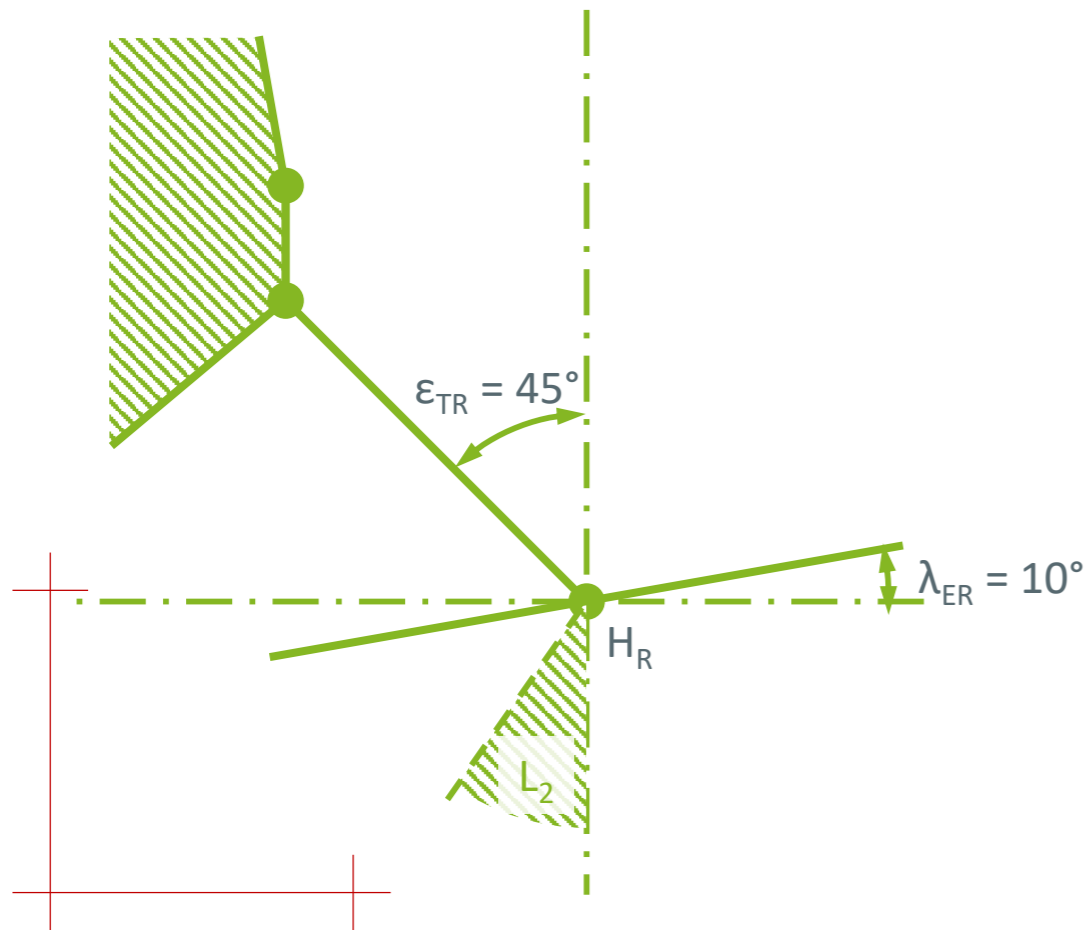

**Buckle Side**

**Configuration No. 5**

Seat Cushion	25°
Backrest	45°
Opening Angle	110°

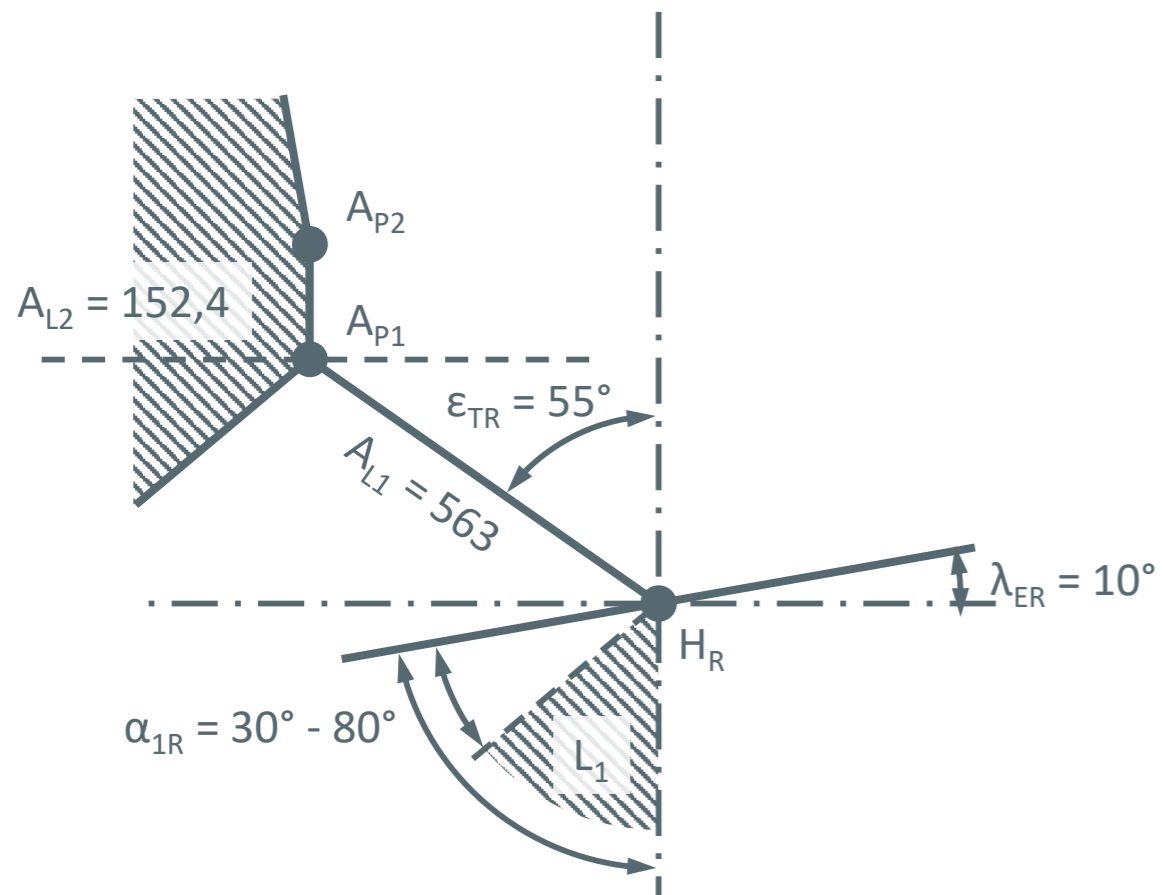

Other than Buckle Side

**Configuration No. 6**

- Seat Cushion 25°
- Backrest 55°
- Opening Angle 120°

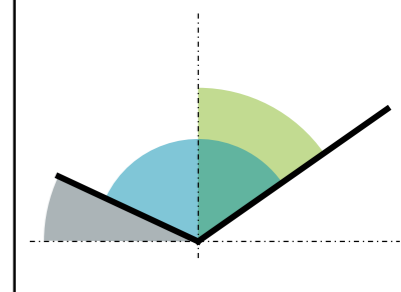



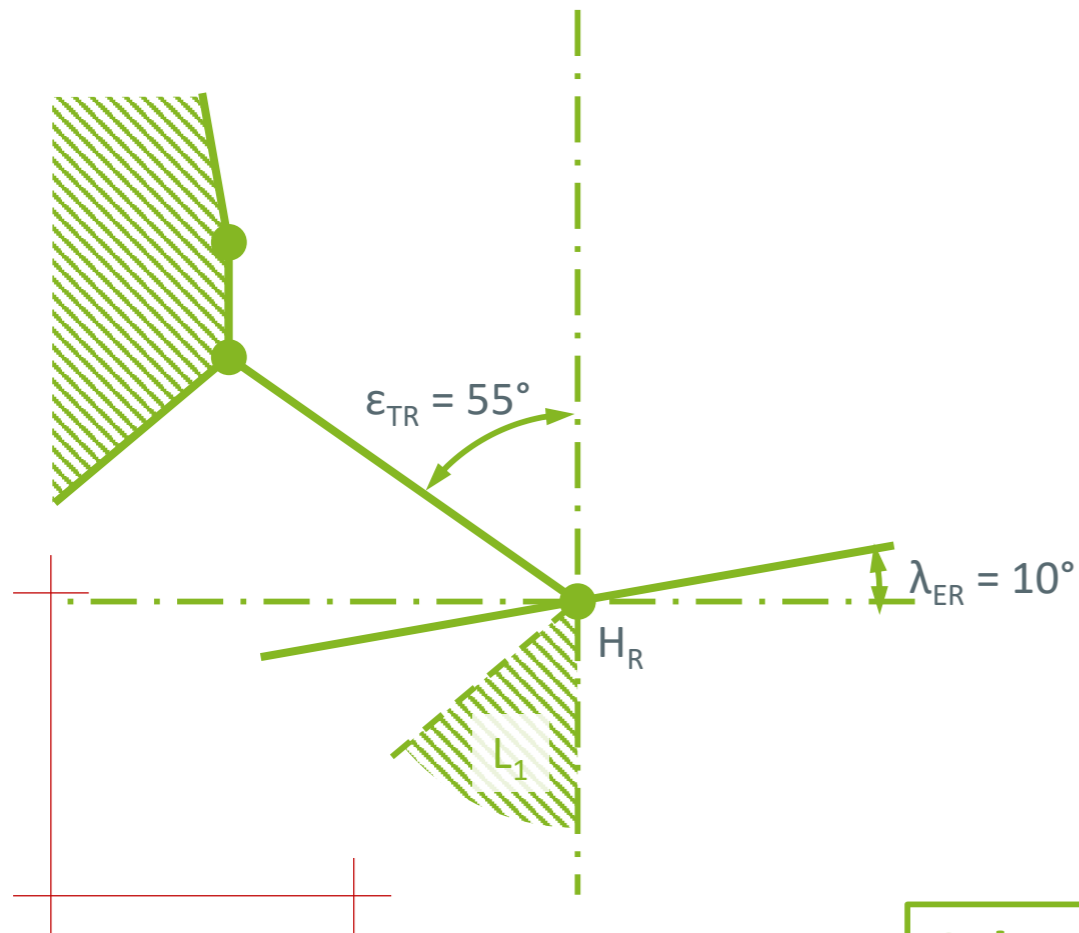

Other than Buckle Side

**Configuration No. 6**

Seat Cushion	25°
Backrest	55°
Opening Angle	120°

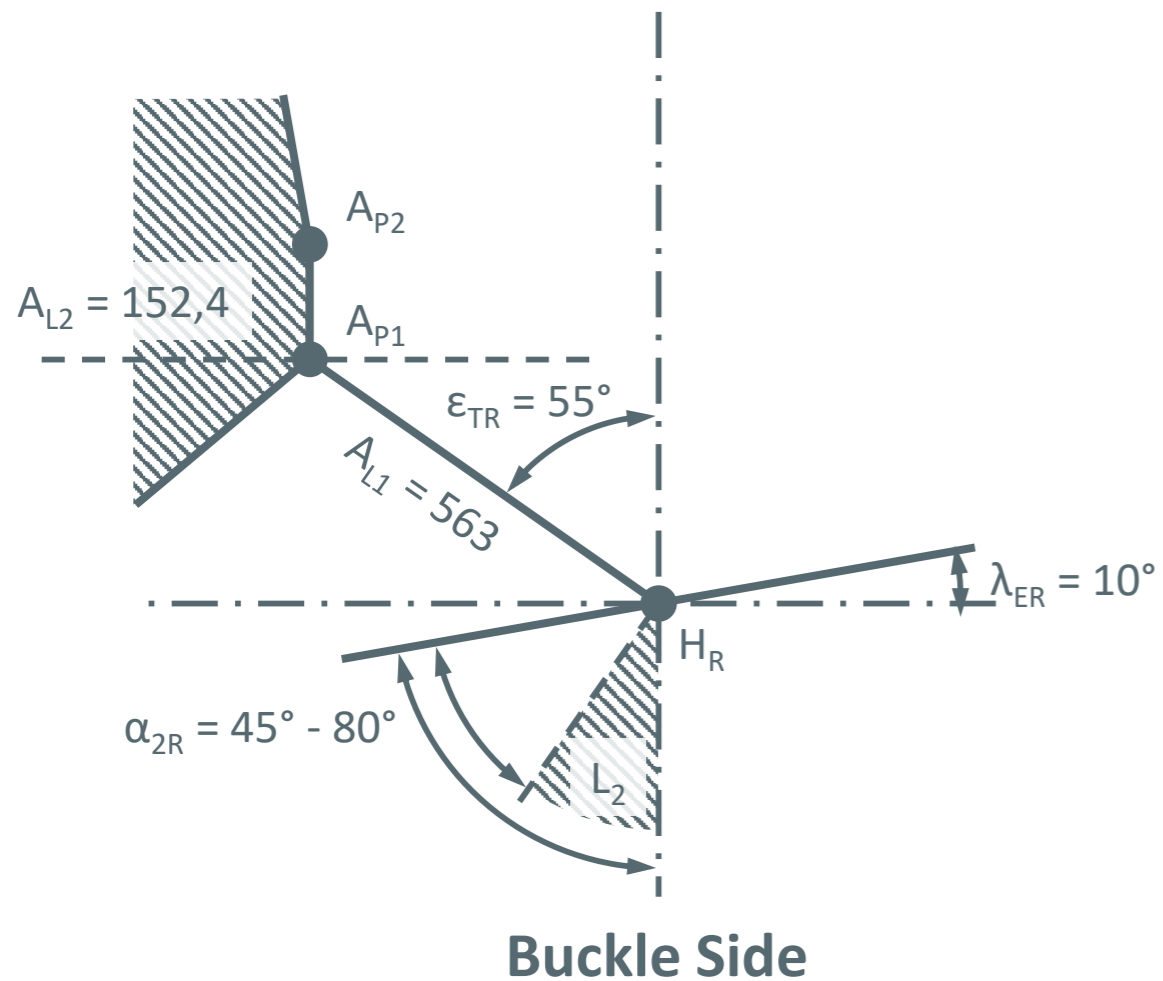

**Configuration No. 6**

- Seat Cushion  $25^\circ$
- Backrest  $55^\circ$
- Opening Angle  $120^\circ$

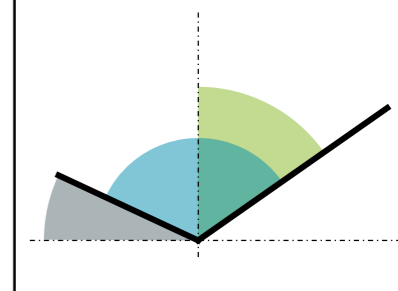

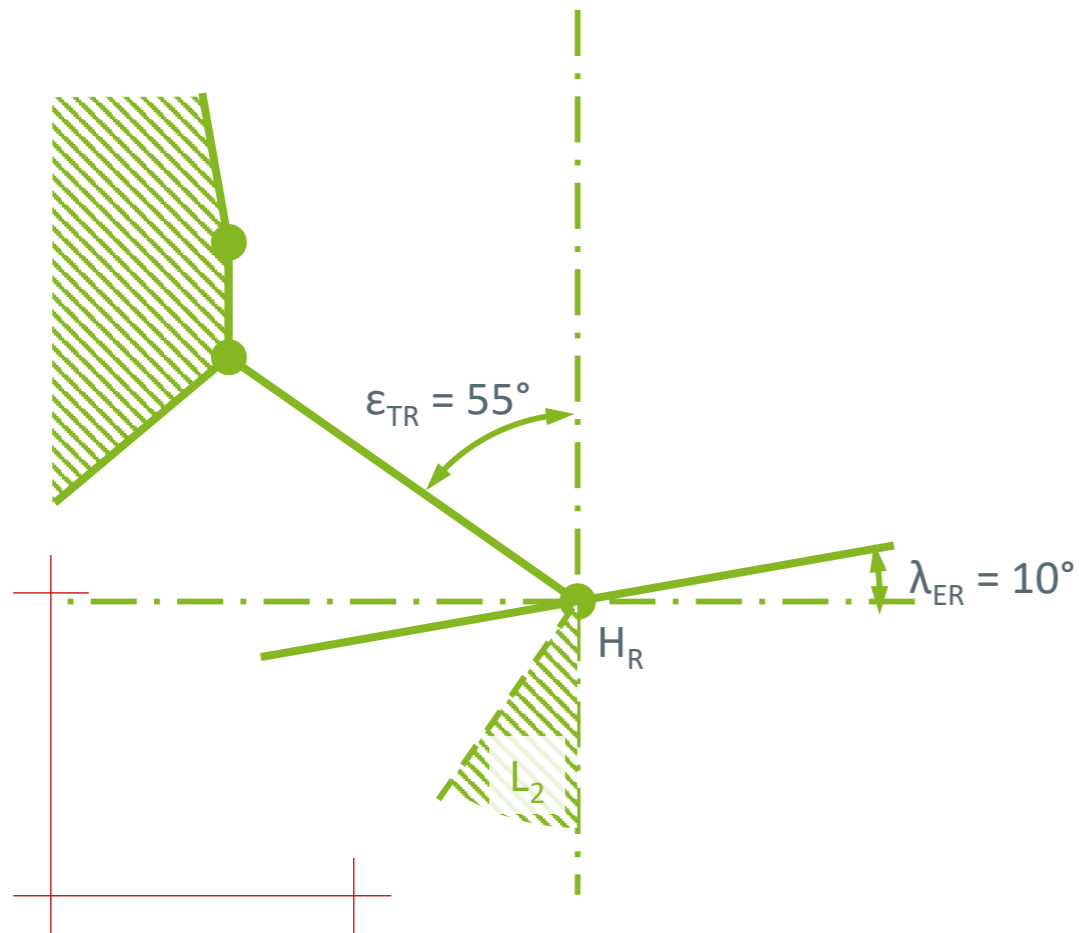

**Buckle Side**

**Configuration No. 6**

Seat Cushion	25°
Backrest	55°
Opening Angle	120°