

BMW/OICA (under alignment)

HYDROGEN MATERIAL COMPATIBILITY, OVERVIEW AND POTENTIAL PATHS FORWARD.

GRSP TF ON THE TRANSPOSITION OF GTR 13 PHASE 2 TO UN R 134.02, BERLIN

26. – 28.08.2024

HISTORY AND CURRENT SITUATION ON THE REGULATION OF HYDROGEN MATERIAL COMPATIBILITY IN ECE (EU + JAPAN).

- Topic was discussed in GTR 13 Phase 1, but no harmonization was achieved („contracting parties continue using their national provisions“).
- EU and Japan remained at their national provisions.
- Topic was again discussed in GTR 13 Phase 2, the view on this topic was aligned. Cumulating in Chris San Marchi's presentation: https://wiki.unece.org/download/attachments/87622122/GTR13-7-08%202019November_GTR_IWG_materials_SAND2019_13337PE.pdf?api=v2
- It proposes to proof the H2 material compatibility via SSRT and FTL test on testprobe level.
- Could not be harmonized due to unavailability of test labs in Europe, other attempts to establish performance based tests on component level failed => „contracting parties continue using their national provisions“
- In Europe EU 2021/535 Annex 14, in Japan Jari 002 (28,5% Nickel-equivalent).

The regulatory situation for the approval of CHSS within ECE is sufficient for the moment, but for the development of innovative future CHSS to constricting (proof of hydrogen material compatibility of metals).

APPROACHES FOR DEMONSTRATING HYDROGEN COMPATIBILITY OF METALLIC MATERIALS.

- **White list approach:** Predefined material list with acceptable pressure range and material composition (e.g. SAE J2579)
- **Performance-based approach:** Proof of hydrogen material compatibility via H₂ cycles with the geometry of the component (e.g. for the container in EC79/2009, EC 2021/535, SAE J2579, ISO 19881)
- **Material tests on test samples (e.g. notched and unnotched, burst disc, a.o.):**
 - SAE J 2579:2018 SSRT (slow strain rate test) and FTL (fatigue life test) as proposed by from Japan in GTR 13 phase 2 (was not implemented due to the unavailability of testing institutes in particular for FTL).
 - ISO 11114-4:2017 burst disc test, fracture mechanic test
 - ISO 7039:2024: Tensile testing with hollow test probes (still in early stage)
- **Additional requirements (e.g. chemical composition, mechanical properties):**
 - Defined chemical composition, e.g. nickel-equivalent of at least 28.5% and mechanical properties, such as e.g. reduction of area or fracture elongation.

There are various approaches for demonstrating hydrogen material compatibility. These include the white list approach, the performance-based approach, tests on test specimens and also via requirement for chemical composition or mechanical properties.

EXAMPLE: HOW TO PROOF H2 MATERIAL COMPATIBILITY IN EU.

	Regulation	Component	Chapter	Content	
Regulatory	ECE R134 - Phase 2 (August 2023)	Uniform provisions for the approval of motor vehicles and motor vehicle components [..]	Compressed hydrogen storage systems and specific components for them	1. Scope	This regulation does not apply [..], the material compatibility and hydrogen embrittlement of the automotive fuel system [..].
	2021/535 (March 2021)	EU implementing regulation [..]	Materials in compressed hydrogen storage systems	3. Hydrogen compatibility test	<ul style="list-style-type: none"> • ISO 11114-1:2017 and ISO 11114-4:2017 under H2 at 700 bar and -40°C • Or in consultation with the type approval authority in accordance with the SAE J 2579:2018 standard

Either..

Or..

ISO 11114-1:2017 and ISO 11114-4:2017

below H2 at 700 bar and -40°C

Transportable Gas Cylinder — Compatibility of Cylinder and Valve Materials with Gas Contents
Part 4: Test methods for selecting metallic materials resistant to hydrogen embrittlement

SAE J 2579:2018 for CHSS

In consultation with the type approval authority
Standard for Fuel Systems in Fuel Cell and Other Hydrogen Vehicles

HYDROGEN COMPATIBILITY IN ACCORDANCE WITH ISO 11114-4 FOR GAS CYLINDERS.

ISO 11114-1:2017 and ISO 11114-4:2017
below H₂ at 700 bar and -40°C
Transportable Gas Cylinder — Compatibility of Cylinder and Valve Materials with Gas Contents
Part 4: Test methods for selecting metallic materials resistant to hydrogen embrittlement

Either..

Disc testing (Method A)

- Burst discs
- P_{H2} vs. P_{He}
- Test disc must be sanded flat and smooth

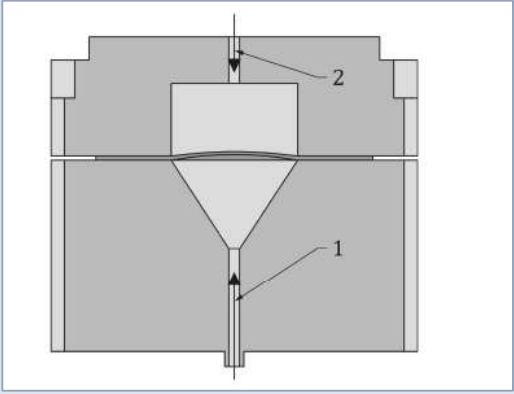

Or..

Fracture Mechanics Test (Method B)

- Determination of the critical stress intensity factor (K_{1H}) for the vulnerability of metallic materials to cracking associated with gaseous hydrogen.

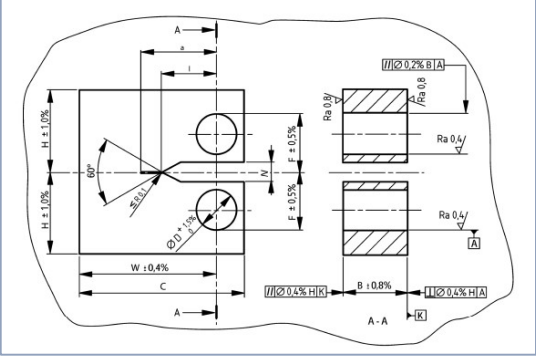

HYDROGEN COMPATIBILITY ACCORDING TO SAE J 2579:2018 FOR CHSS.

SAE J 2579:2018 for CHSS In consultation with the type approval authority Standard for Fuel Systems in Fuel Cell and Other Hydrogen Vehicles

Either..

Or..

Material compatibility test (B3)

- Initial screening: slow strain rate test, SSRT
- Material Qualification Test: Fatigue Life Test
- No test lab in Europe available.

"White List" table (B2)

- Material list with/without restrictions and material composition
- Materials that have demonstrated their suitability in several applications.

Design specific hydrogen compatibility test (B.4)

- 4 tanks, 2x burst pressure, 2x H2 cycles
- 2MPa up to 125% NWP, pressure build up: >5 min, holding time: 2 min
- 1st tank @ -50°C and -35°C H2
- 2nd tank @ +20°C and 20°C H2
- 11,000 cycles without bursting, 5,500 without leakage
- At 2 cycles/h at individual container level

11,000 cycles
Possible for innovative container concepts, as it takes into account the relevant parameters of material, manufacturing process and design.

Table B3 - Summary of materials definition and testing requirements for high pressure hydrogen material compatibility

Property	Materials definition from materials standard (minimum property values per 8.3.2.1)	Materials verification (measured values per 8.3.2.1)	Qualification testing in hydrogen (8.3.2 and 8.3.3)
Environment	-	In air at room temperature per standard testing procedures	In gaseous hydrogen at pressure of 1.25NWP and temperature from Table B4
Yield strength	Sy	≥Sy	≥Sy
Tensile strength	Su	≥Su	≥Su
Strain hardening capacity	Su/Sy > 1.07	> 1.07	> 1.07
Elongation	EI	≥EI	≥12%
Fatigue	-	-	N > 2x10 ⁷ (smooth) N > 10 ⁷ (notched) for maximum nominal stress 0.15 Su

Table B2 - Qualification of hydrogen compatibility based on usage conditions

Material	NWP	Material Composition and Processing	Design Guidance at 1.5NWP
Steel 12 S21603, S31608 (China) DIN 14401 (Germany) DIN 14404 (Germany) DIN 14435 (Germany) UNS S21600/SAISI 316 (USA) UNS S31603/SAISI 316L (USA)	<70 MPa	No restrictions, except note b	No significant degradation under hydrogen service for infinite life design ^a
Steel 11 SUS304 (Japan) SUS316 (Japan) SUS316L (Japan)	<70 MPa	Austenitic stainless steel with solid solution heat treatment	No significant degradation under hydrogen service for infinite life design ^a
Steel 11 S21603, S31608 (China) DIN 14401 (Germany) DIN 14404 (Germany) DIN 14435 (Germany) UNS S21600/SAISI 316 (USA) UNS S31603/SAISI 316L (USA)	<70 MPa	≥15% N ^b ≥0.25% N ^b Note b	No significant degradation under hydrogen service
Steel 11 DIN 14433 (Germany) UNS S21702/DIN 1.4438 DIN 1.3902 (Germany) UNS N08904/DIN 1.4529 UNS N08904/DIN 1.4529	<70 MPa	No restrictions, except note b	No significant degradation under hydrogen service
Aluminum ^c A6061-T6 A6061-T62 A6061-T651 A6061-T6511	<70 MPa	No restrictions	No significant degradation under hydrogen service

Table B4 - Test temperature

Alloy type	Test Method	Test temperature (°C)
Austenitic stainless steel	SSRT	228 ± 5
	Fatigue life	228 ± 5 and 293 ± 5
Nickel-based alloys	SSRT and Fatigue life	228 ± 5
	SSRT and Fatigue life	293 ± 5
Aluminum, magnesium and copper alloys	SSRT and Fatigue life	293 ± 5
Other alloys	SSRT and Fatigue life	228 ± 5 and 293 ± 5

- With SAE J 2579:2018 hydrogen compatibility for CHSS components can be carried out using material tests, the white list approach or performance-based with H2 component cycles.
- Performance-based testing via H2 cycles on the component is a suitable way to demonstrate hydrogen material compatibility on innovative CHSS concepts.

POTENTIAL WAYS FORWARD TO REGULATE HYDROGEN MATERIAL COMPATIBILITY FOR METALS IN UN R 134.

- Update on the availability of test centers in Europe for FTL.
- Consider the establishment of a material white list.
- Continue the discussion whether a performance based test on the component level especially can find general acceptance as long as suitable material tests on testprobe level are not available.
- Other proposals?

BACKUP.

TEXT OF EU REGULATION EU 2021/535.

3. Hydrogen compatibility test

- 3.1. For metallic materials used in CHSS, hydrogen compatibility of the material, including that of welds, shall be demonstrated in accordance with international standards ISO 11114-1:2017 and ISO 11114-4:2017, with the tests carried out in hydrogen environments as anticipated in service (e.g. in case of 70 MPa systems, the hydrogen compatibility testing is carried out in 70 Mpa environment at the temperature of -40 °C). Alternatively, in agreement with the technical service and the type-approval authority, compliance may be demonstrated in accordance with the standard SAE J2579:2018.