

European
Automobile
Manufacturers
Association

TF-BTA-8-04

Task Force Bumper Test Area

COB determination
Explanation of gauge procedure

WebEx Conference, 21st November 2014

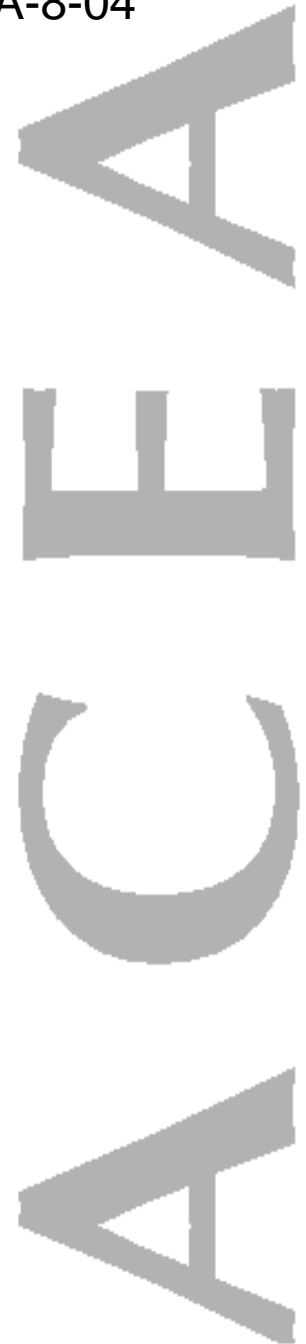



Task Force Bumper Test Area

COB determination – gauge procedure

A

Proposal in draft regulative language

B

Explanation of gauge procedure



Task Force Bumper Test Area

COB determination – gauge procedure

Language proposal (UNECE Regulation No 127)

2.17. "Corner of bumper" means **the transversal position** of the vehicle's point of contact with a **corner gauge** as defined in **Figure 5B**.

Figure 5B: Corner gauge

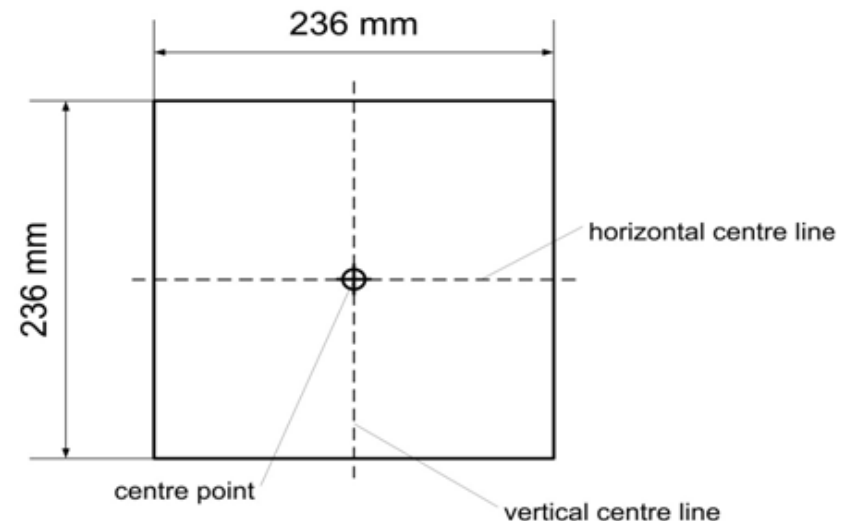

The front surface of the corner gauge is flat.
The centre point is the intersection of the vertical and horizontal centre lines on the front surface.



Task Force Bumper Test Area

COB determination – gauge procedure

Language proposal (UNECE Regulation No 127)

For determination of the corner of bumper, the front surface of the corner gauge is moved parallel to a vertical plane with an angle of 60° to the vertical longitudinal centre plane of the vehicle (see Figures 5A and 5C) **at any height of the centre point of the corner gauge** in the following area:

Figure 5A: Corner of bumper example (see paragraph 3.13., note that the corner gauge is to be moved in vertical and horizontal directions to enable contact with the outer contour and front fascia of the vehicle)

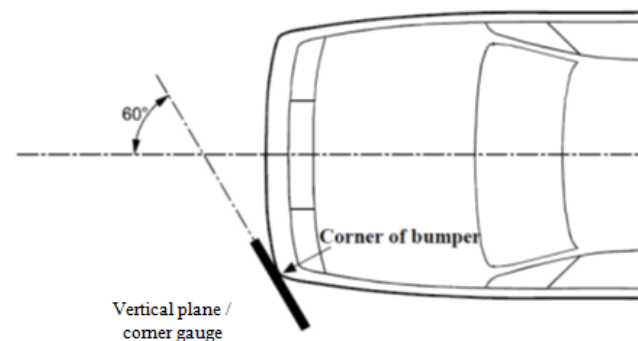



Task Force Bumper Test Area

COB determination – gauge procedure

Language proposal (UNECE Regulation No 127)

- a. Equal to and above the point found on the vertical line intersecting the Lower Bumper Reference Line at the assessment position in transversal direction or at 75 mm above the ground reference plane, whichever is higher.
- b. Equal to and below the point found on the vertical line intersecting the Upper Bumper Reference Line at the assessment position in transversal direction or at 1003 mm above the ground reference plane, whichever is lower.

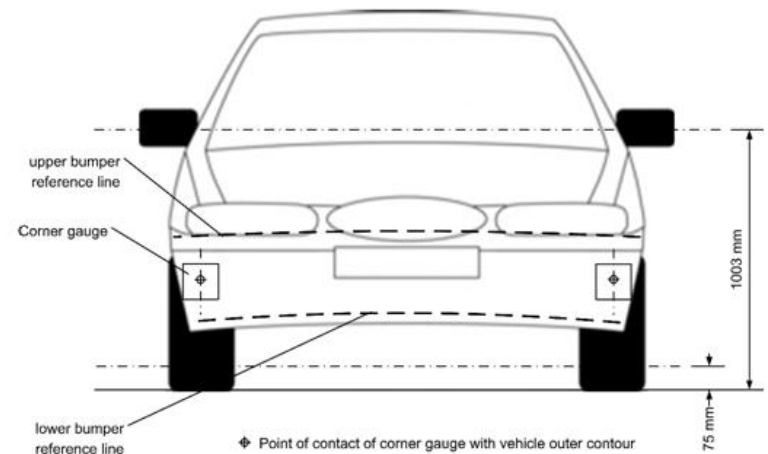



Task Force Bumper Test Area

COB determination – gauge procedure

Language proposal (UNECE Regulation No 127)

- a. Equal to and above the point found on the vertical line intersecting the Lower Bumper Reference Line at the assessment position in transversal direction or at 75 mm above the ground reference plane, whichever is higher.

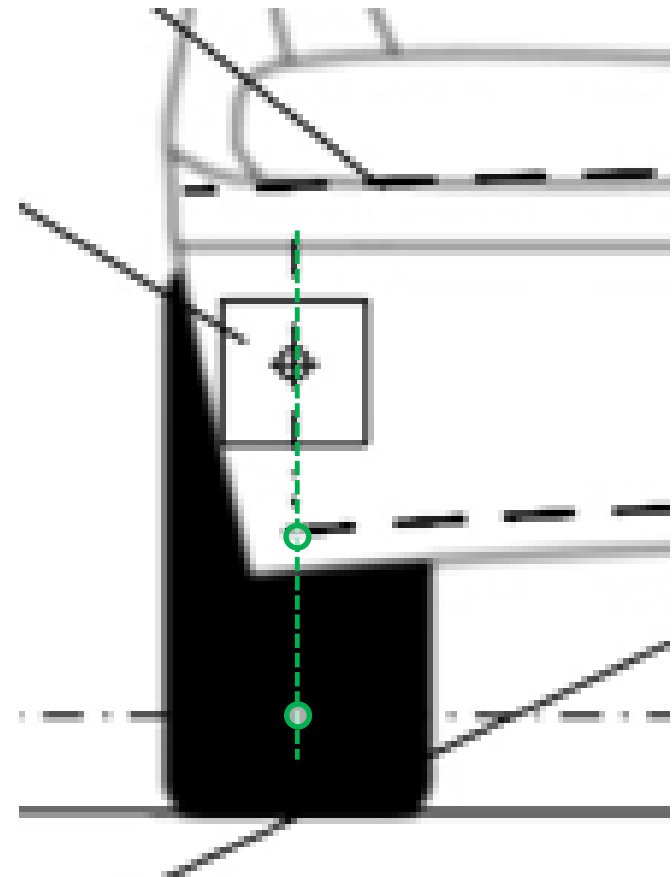



Task Force Bumper Test Area

COB determination – gauge procedure

Language proposal (UNECE Regulation No 127)

- b. Equal to and below the point found on the vertical line intersecting the Upper Bumper Reference Line at the assessment position in transversal direction or at 1003 mm above the ground reference plane, whichever is lower.

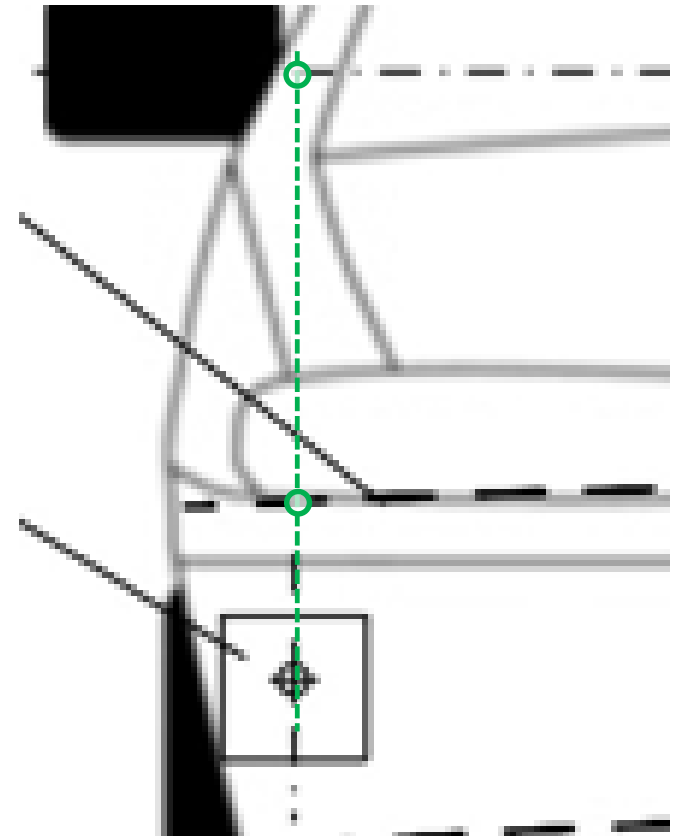



Task Force Bumper Test Area

COB determination – gauge procedure

Language proposal (UNECE Regulation No 127)

For determination of the corner of bumper, the gauge is moved to contact the outer contour and front fascia of the vehicle touching at the vertical centreline of the gauge.

The corners of bumper on both sides are subsequently defined as the most outboard points of contact of the gauge with the outer contour and front fascia of the vehicle as determined in accordance with this procedure.



Task Force Bumper Test Area

COB determination – gauge procedure

COB – on vehicle

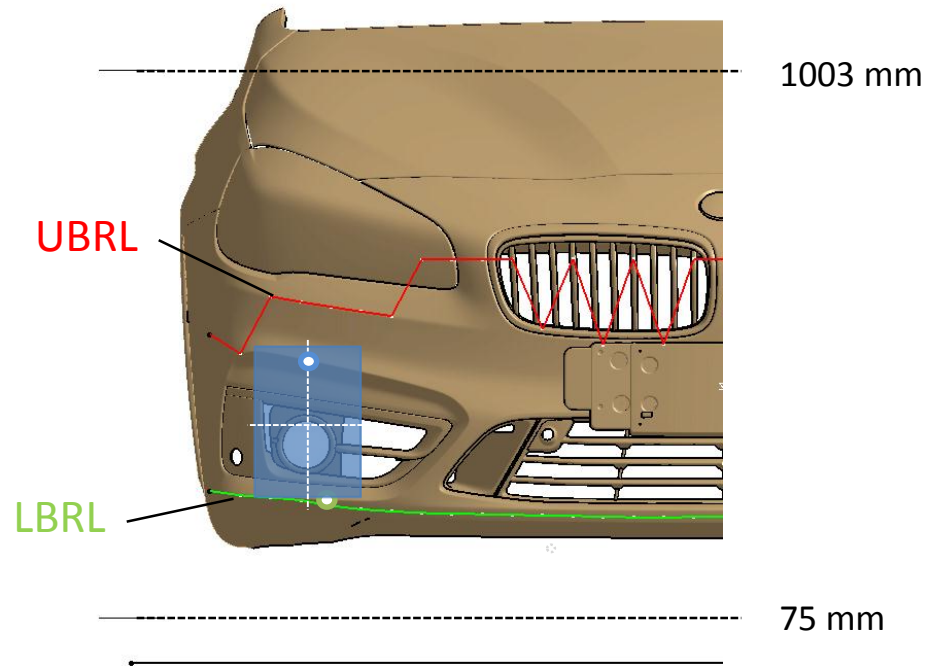

- The gauge is moved to touch at its vertical centre line
- The orientation of the gauge must be maintained during the assessment procedure
- Gauge touches on most outboard point, found at the vehicles outer contour



Task Force Bumper Test Area

COB determination – gauge procedure

Gauge in lowermost assessment position

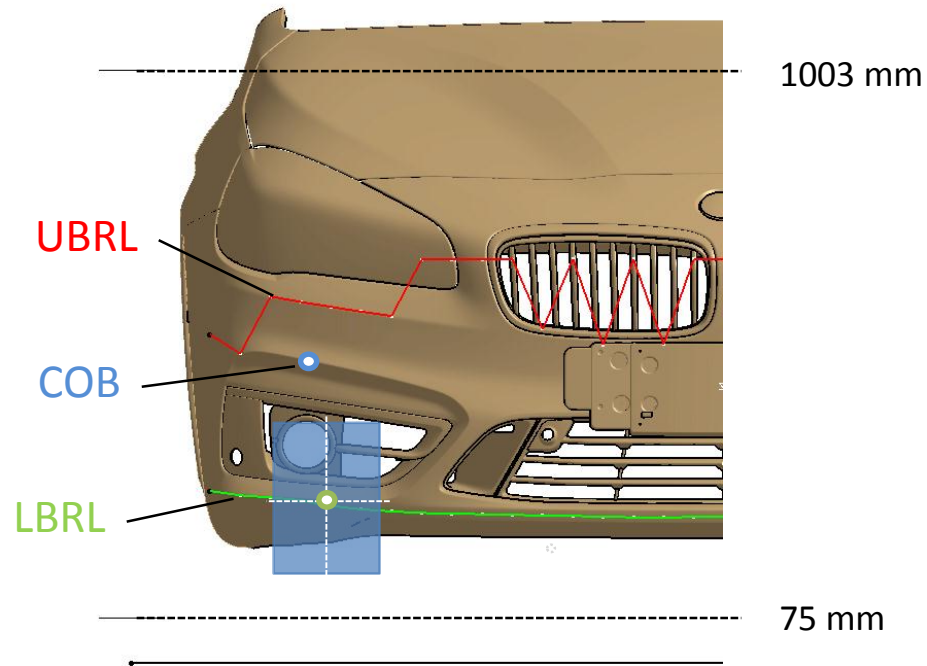

- The assessment height of the gauge is determined at its centre point
- In example the LBRL determines the minimum height of the gauge



Task Force Bumper Test Area

COB determination – gauge procedure

Gauge in uppermost assessment position

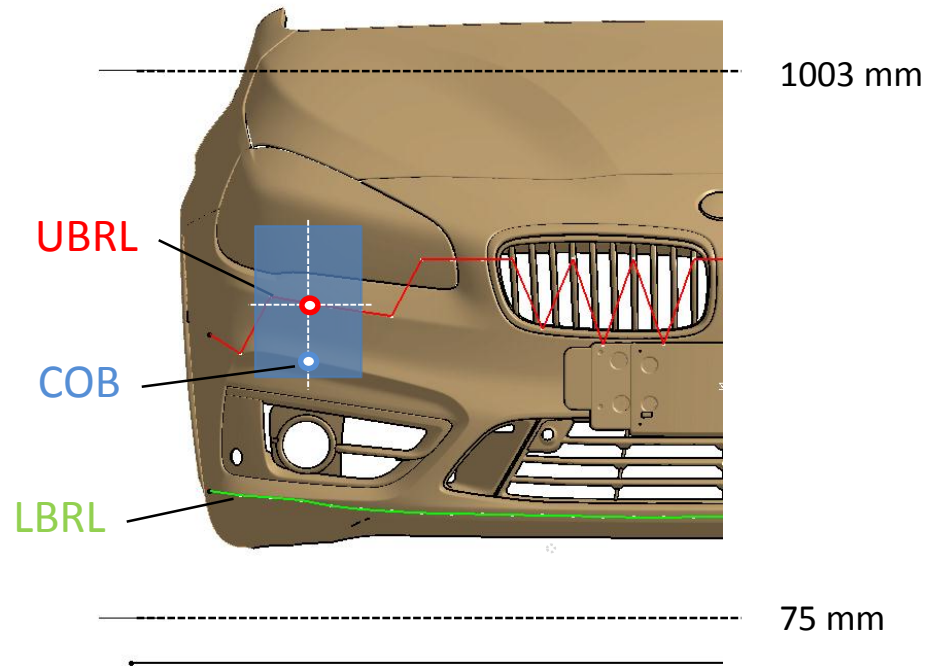

- The assessment height of the gauge is determined at its centre point
- In the example, the UBRL determines the highest position of the gauge
- The gauge contacts the outer contour at a point on the vertical centre line



Task Force Bumper Test Area

COB determination – gauge procedure

Thank you for your attention

On behalf of ACEA provided by:
Winfried Schmitt, BMW



Task Force Bumper Test Area

COB determination – gauge procedure

BACK-UP



Task Force Bumper Test Area

COB determination – gauge procedure

"Upper bumper reference line" means a line which identifies the upper limit to significant points of pedestrian contact with the bumper. It is defined as the geometric trace of the upper most points of contact between a straight edge 700 mm long and the bumper, when the straight edge, held parallel to the vertical longitudinal plane and inclined rearwards by 20°, is traversed across the front of the vehicle, while maintaining contact with the ground and with the surface of the bumper (see Figure 10).

Where necessary the straight edge shall be shortened to avoid any contact with structures above the bumper.

Figure 10
Upper Bumper Reference Line (UBRL)

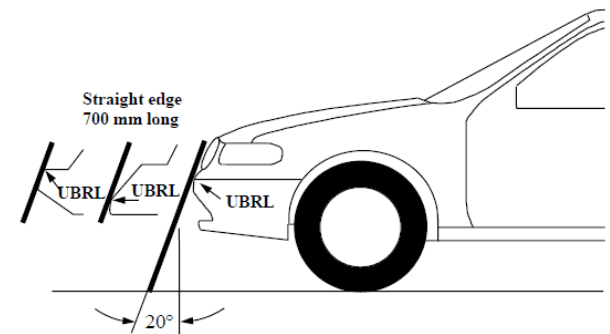



Task Force Bumper Test Area

COB determination – gauge procedure

"Bumper" means the front, lower, outer structure of a vehicle. It includes all structures that are intended to give protection to a vehicle when involved in a low speed frontal collision and also any attachments to this structure. The reference height and lateral limits of the bumper are identified by the corners and the bumper reference lines.

Figure 10
Upper Bumper Reference Line (UBRL)

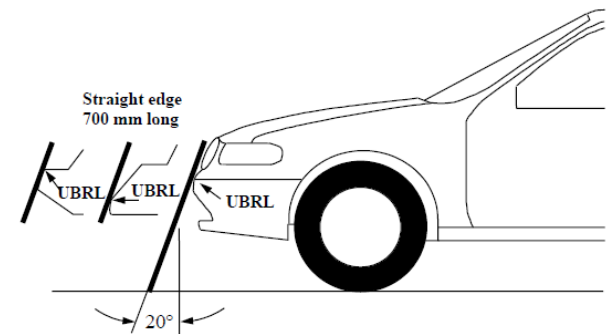



Task Force Bumper Test Area

COB determination – gauge procedure

"Lower bumper reference line" means the lower limit to significant points of pedestrian contact with the bumper. It is defined as the geometric trace of the lowermost points of contact between a straight edge 700 mm long and the bumper, when the straight edge, held parallel to the vertical longitudinal plane of the vehicle and inclined forwards by 25° from the vertical, is traversed across the front of the vehicle, while maintaining contact with the ground and with the surface of the bumper (see Figure 8).

Figure 8
Lower Bumper Reference Line (LBRL)

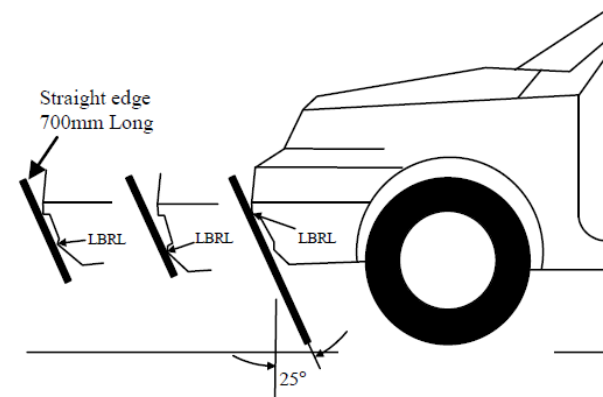



Task Force Bumper Test Area

COB determination – gauge procedure

"*Bonnet leading edge reference line*" means the geometric trace of the points of contact between a straight edge 1,000 mm long and the front surface of the bonnet, when the straight edge, held parallel to the vertical longitudinal plane of the car and inclined rearwards by 50° from the vertical and with the lower end 600 mm above the ground, is traversed across and in contact with the bonnet leading edge (see Figure 1). For vehicles having the bonnet top surface inclined at 50°, so that the straight edge makes a continuous contact or multiple contacts rather than a point contact, the reference line is determined with the straight edge inclined rearwards at an angle of 40° from the vertical.

For vehicles of such shape that the bottom end of the straight edge makes first contact, then that contact is taken to be the bonnet leading edge reference line, at that lateral position.

For vehicles of such shape that the top end of the straight edge makes first contact with the vehicle, then the geometric trace of 1,000 mm wrap around distance will be used as the bonnet leading edge reference line at that lateral position.

The top edge of the bumper shall also be regarded as the bonnet leading edge for the purposes of this Regulation, if it is contacted by the straight edge during this procedure.