

# ISO activity

2015 Oct.



HEV System Power WG  
Japan Automobile Research Institute

# Schedule

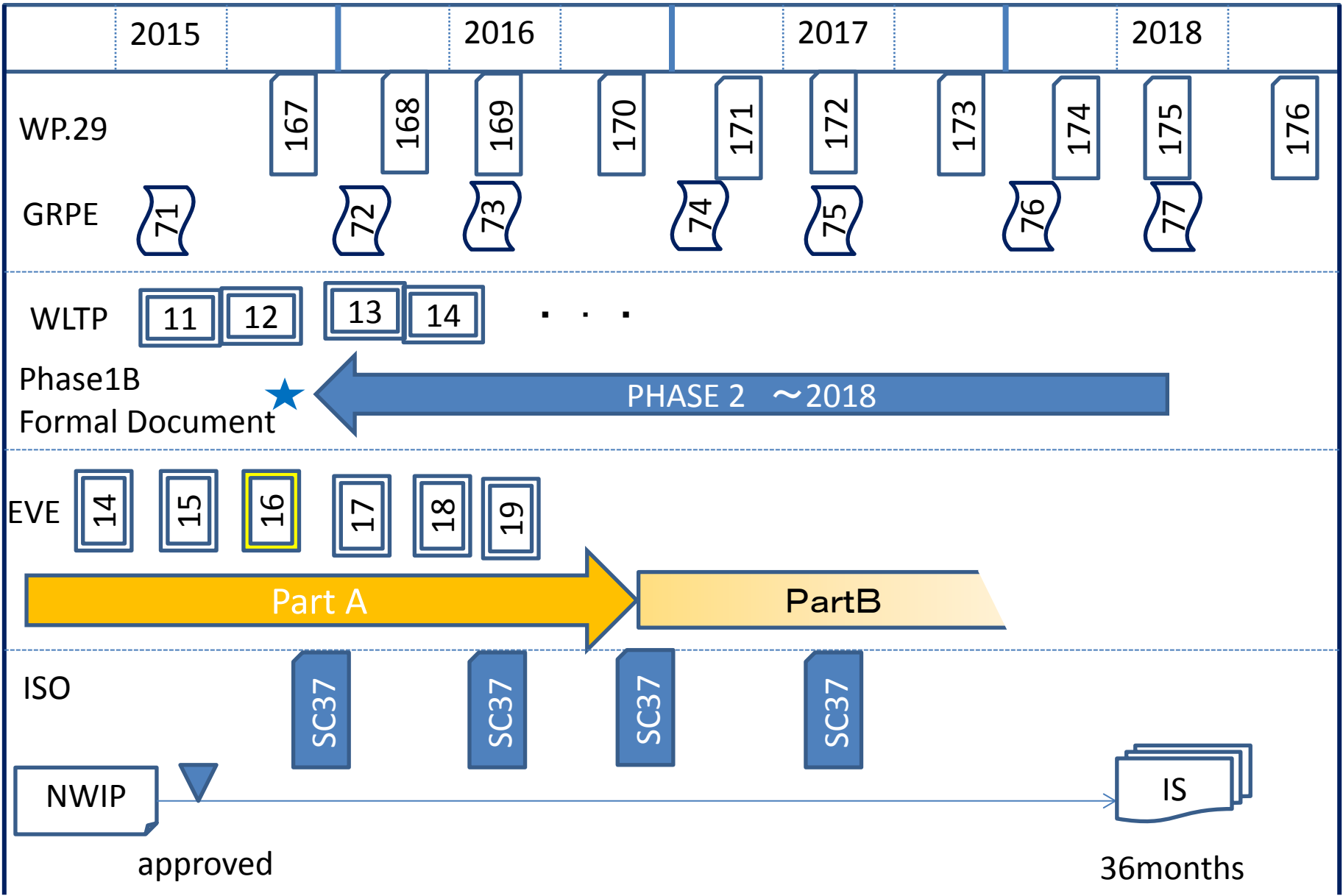

# Schedule

ISO SC37/WG2 voting result

NWIP was approved Jun 22<sup>nd</sup>.

ISO/WD20762 Electrically propelled road vehicles –

Determination of power for propulsion of hybrid electric vehicles

Next WG2 meeting will be held on week of Dec.15<sup>th</sup>

2015

2016

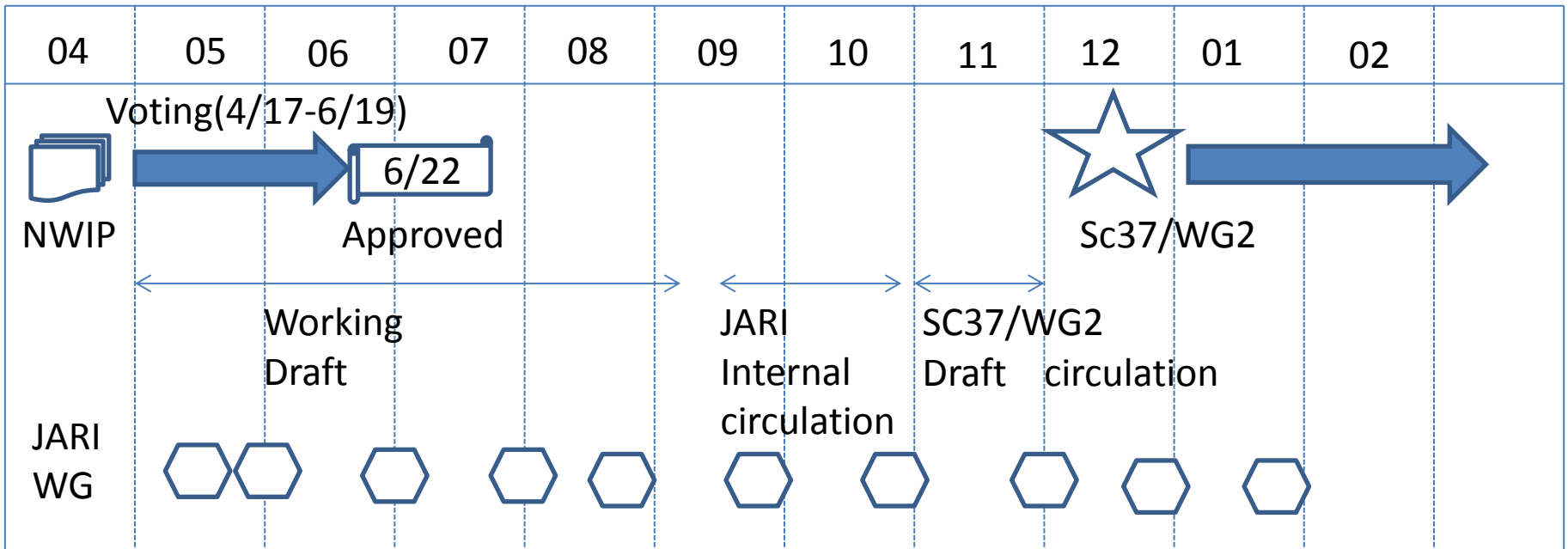

# Determination of power for propulsion of hybrid electric vehicle



HEV System Power WG  
Japan Automobile Research Institute

## New work item for HEV

---

### □ Title for an International Standard

“Determination of power for propulsion of hybrid electric vehicle(HEV)”

◆ Contents: Test procedure to determine the maximum HEV system power

◆ Items should be achieved

- 1) The results can be easily compared with the rated power of internal combustion engine(ICE) vehicle measured with the current test procedure such as UN R85.
- 2)The method can apply to most of HEV systems.
- 3)The method should have enough accuracy and repeatability.

◆ Background

- 1) There is no international standard or regulation.
- 2) It is necessary for manufactures to show the reasonable power value of HEV system and compare it with the value of the ICE power measured in the existing test method.
- 3) There is a request from WLTP informal group to develop a reasonable power determination procedure to classify the HEVs.

- ✓ Manufacturers show the maximum HEV system power in their catalogues in their own way, because there is no unified evaluation method for HEVs.
- ✓ An appropriate test procedure has been required for the purpose of proper consumer information.

| TECHNICAL DATA                     |  |
|------------------------------------|--|
| Combustion engine:                 | 110 kilowatts/150 hp                   |
| Electric motor:                    | 75 kilowatts/102 hp                    |
| System:                            | 150 kilowatts/204 hp                   |
| Maximum torque, combustion engine: | 250 newton metres                      |
| Maximum torque, electric motor:    | 330 newton metres                      |
| Maximum torque, system:            | 350 newton metres                      |
| Electric range:                    | 50 kilometres                          |
| Electric consumption:              | 11.4 kilowatt hours per 100 kilometres |

✓ There is a vehicle classification requirement for ICE vehicles to determine the cycles to be driven in the UN-GTR No.15 (WLTP) . Currently, pure and hybrid electric vehicles shall be considered to be Class 3 vehicles.

WLTP(GTR No.15)

Classification

Power Mass ratio and Max Speed

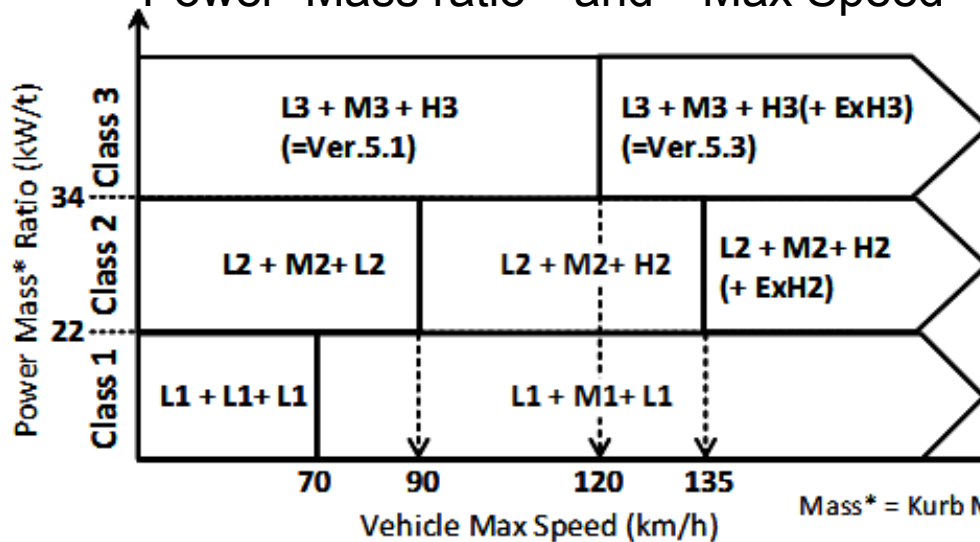

Downscale

(Application of the drive cycle by power)

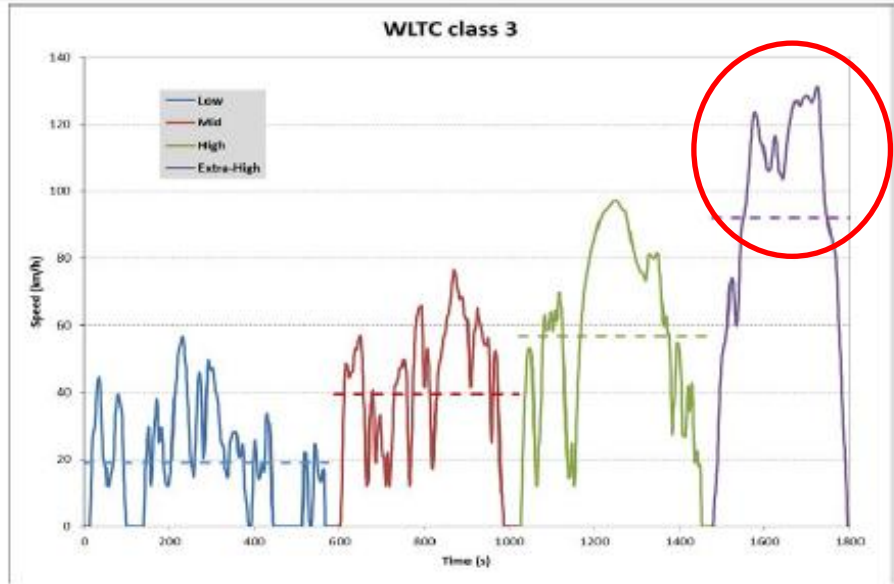

If an appropriate test procedure for the hybrid system power determination is developed, HEVs can be classified in a same manner as ICE vehicles.

## Maximum HEV system power at present

**There is no regulation or standard to evaluate and determine "maximum hybrid electric vehicle system power".**

- Existing International Standards and Regulations in terms of power measurement  
ISO1585:Road vehicles — Engine test code — Net power  
-> This specifies how to measure the net power of ICE.

UN R85 : Power Measurement of Internal Combustion Engines and Electric Motors

-> This specifies how to measure the power of ICE and that of electric motor respectively.

It doesn't specify the HEV system power which derives from an ICE, an electric motor(s) and a battery.

- How to express the power of HEV at present  
In catalogues, manufacturers show the maximum power in their own way to express.

**There is no regulation or standard to evaluate and determine the maximum HEV system power and be able to compare it with the rated power of ICE Vehicle.**



To define the HEV system power, an internal combustion engine, an electric motor and a traction battery are important parts.

HEV systems have various configurations and controls. The power of HEV depends on how these important parts are controlled in close coordination each other.

The role of the motor in the HEV is different in each HEV system. It is not so simple as we only measure and add the motor power to the power of ICE.

The idea how we can define the HEV system power is shown in the following slides.

# ICEV propulsion system

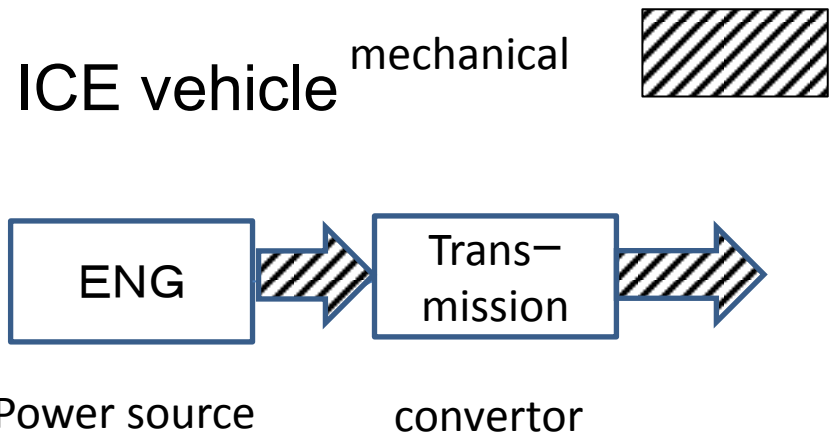

ICE vehicle in comparison with HEV has propulsion system which consisted of ICE and transmission.

Transmission changes the engine speed of crankshaft end to the speed suitable for vehicle propulsion.

# Examples of HEV system

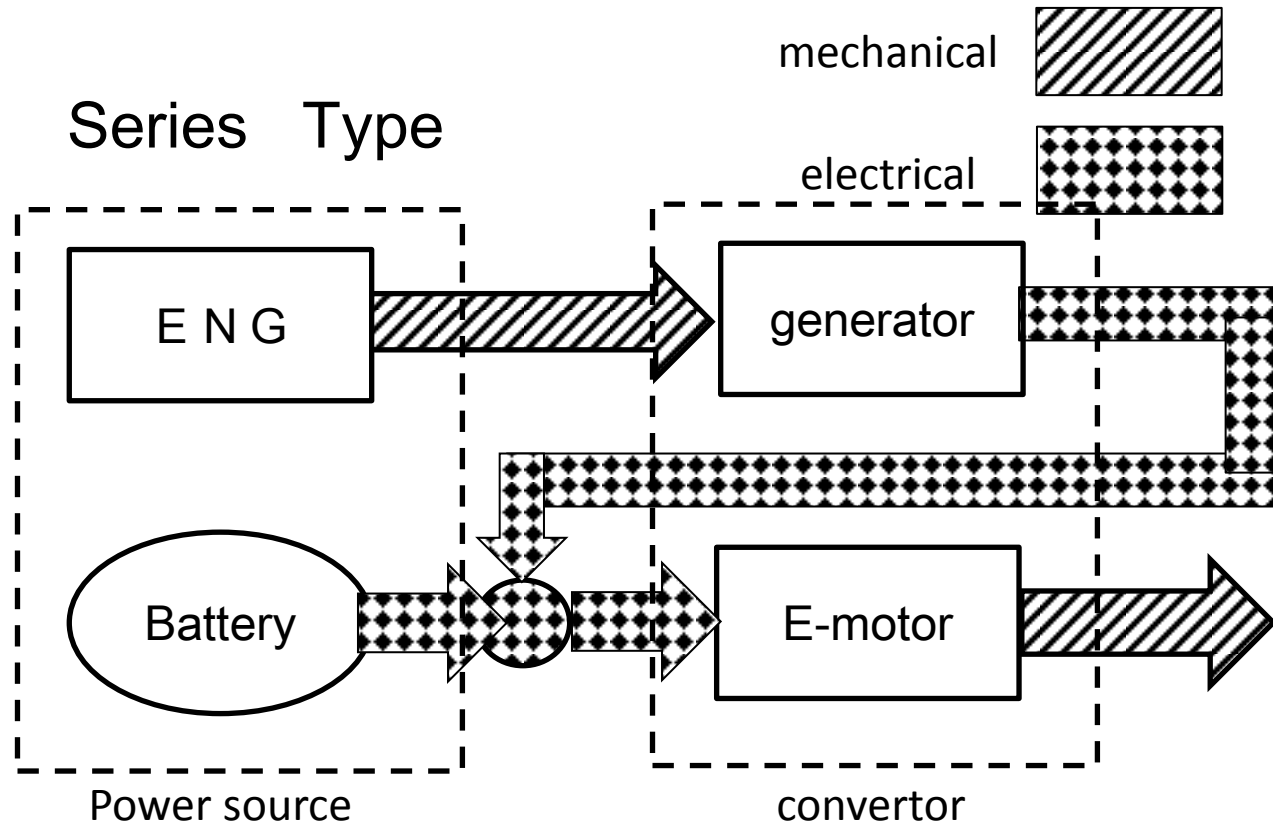

The vehicle is propelled by (using) only electric motor.  
 The ICE is used only for generating electricity.

# Examples of HEV system

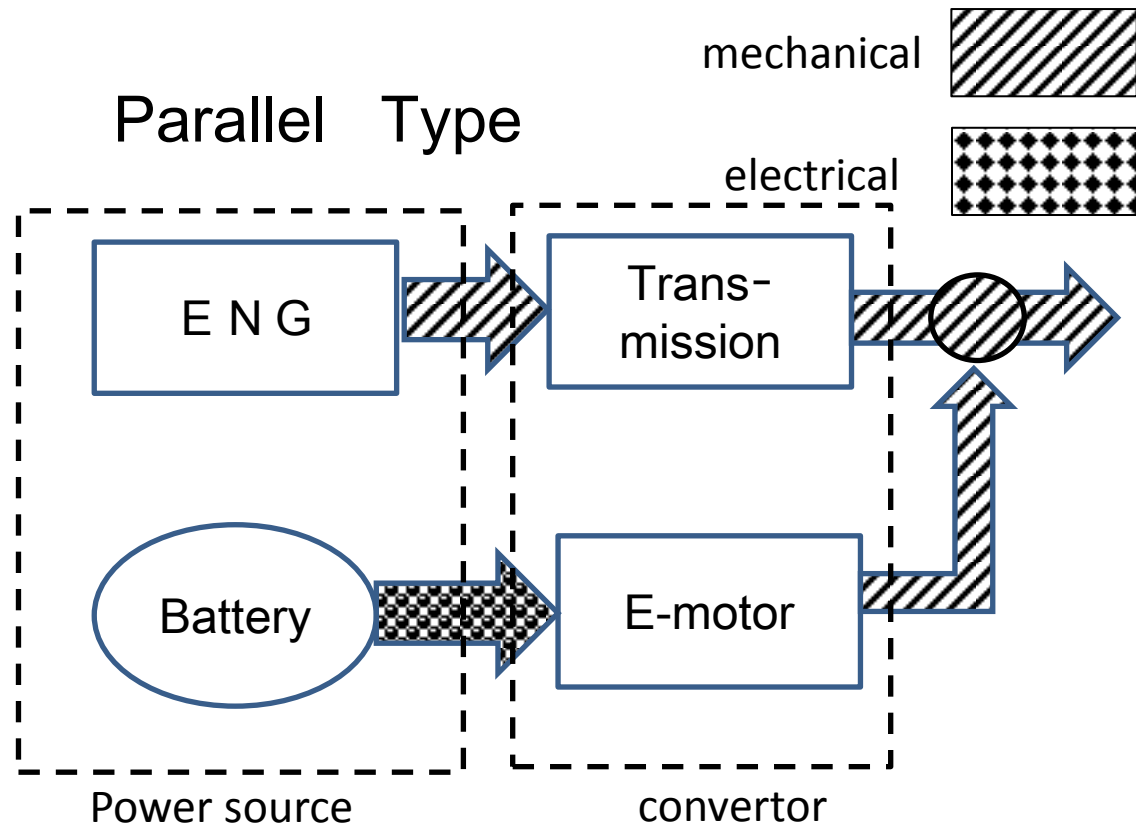

The vehicle is propelled by both of the ICE and the electric motor in parallel.

# Example of study of HEV system

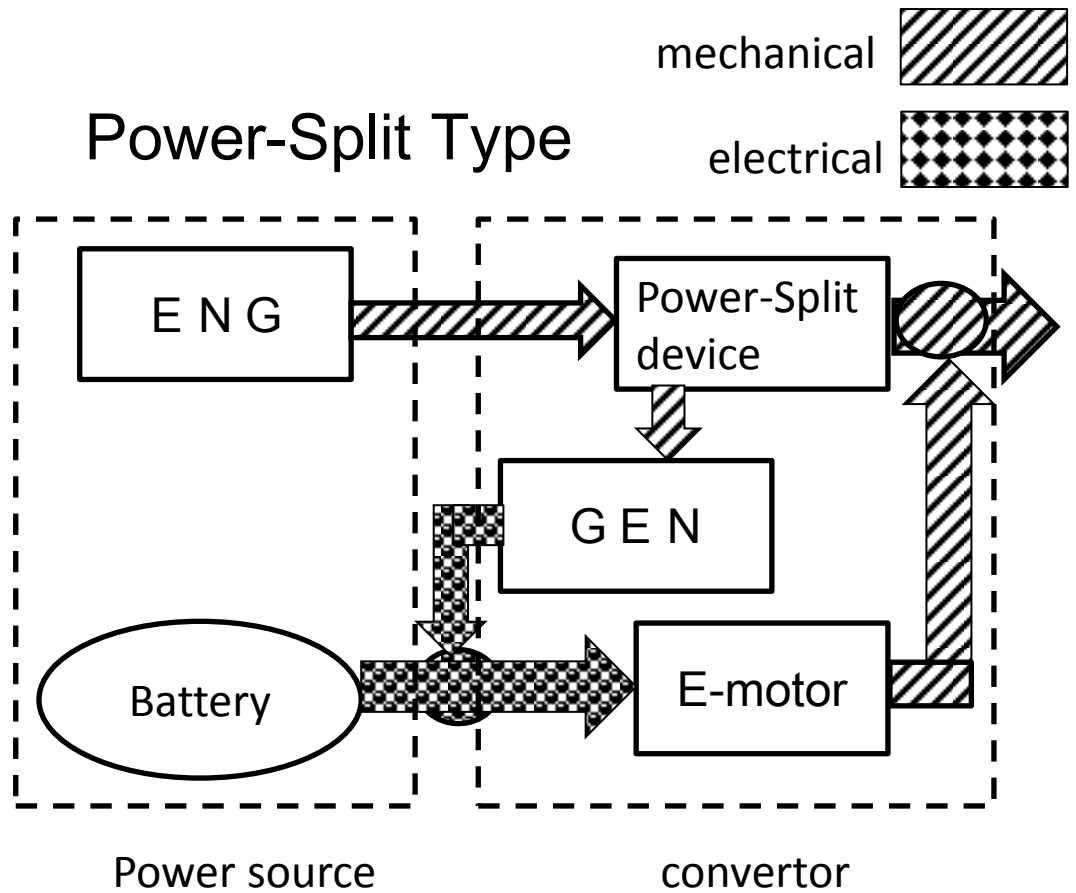

The vehicle is propelled by the electric motor only or both of the ICE and the electric motor in parallel, which depends on the vehicle's operational conditions.

The ICE power is divided into the direct traction and the generating electricity by the power split device.

# Summary 1

In the HEV system, not only the ICE output but also the battery output contribute to propel the vehicle.

- ❑ For ICE Vehicles, the maximum power in the catalogue is the rated power of the ICE.
- ❑ The rated powers in catalogues are measured by the same test procedures such as ISO, UN regulation and regional standards and regulations.
  
- ❑ In order to compare the power of HEVs with that of ICEVs, the ICE power of HEVs should also be measured.
- ❑ But, in addition to the ICE, HEVs have a motor(s) and a propulsion battery as an electric power system.
  
- ❑ We recommend to measure the battery power, not the motor power.

Why is maximum HEV system power determined by the ICE power and battery power instead of the motor power?

□ The battery and ICE are only power sources of the HEV system. Measuring the battery output power is an ideal approach to determine the output power from the electric power system separated from the ICE power. The output can be measured by testing the vehicle as a whole.

In conclusion, the value of maximum HEV system power can be obtained from both of the ICE power and battery power.

Rev.  
Throttle

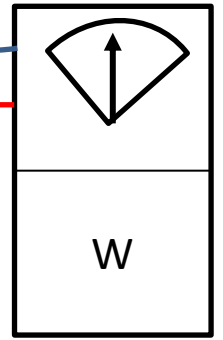

Constant  
speed control

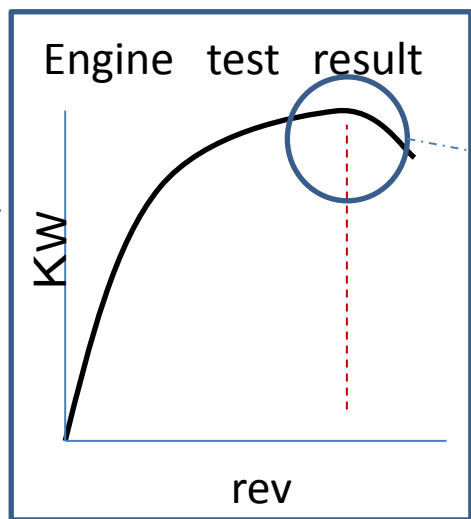
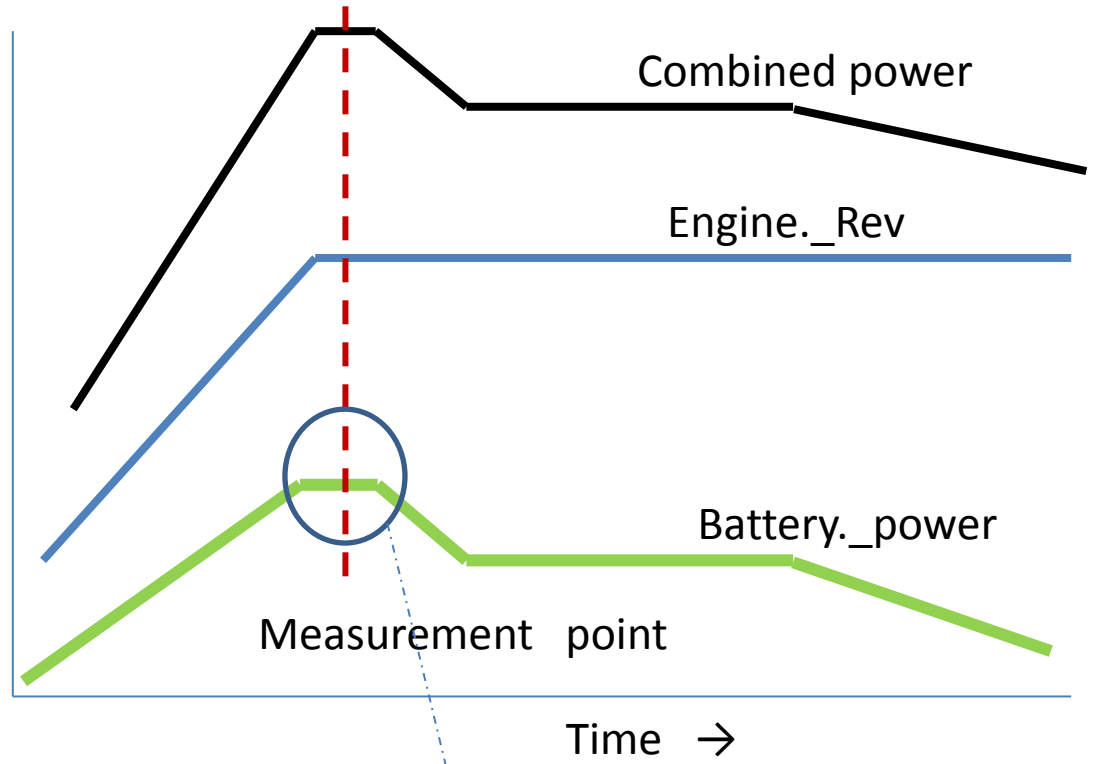

Engine + Battery = Maximum HEV system power



## Determination of maximum HEV system power of hybrid electric vehicle

- ❑ To evaluate and determine :

ICE power + Battery power = HEV system power

- It is necessary to measure the battery output under the HEV system control. The battery output should be measured when the HEV system as a whole (is considered as) outputs the maximum power.



- ❑ To measure condition at the time of maximum output of ICE and battery .

- The battery output in HEVs have different output profiles depending on each vehicle system design, such as the value of the maximum power, the duration of the maximum power, timing.



- ❑ To measure the engine operating status and the battery output of the vehicle with accelerating condition on the chassis-dynamometer set up under wide open throttle driving of the tested vehicle.
- ❑ To obtain an ICE maximum power curve independently. Using this power curve and battery output profile, to determine the point of maximum hybrid system power.
- ❑ To combine the ICE output value from the record and the measured battery output. The combined outputs could be comparable to the rated ICE power of the ICEV<sub>17</sub>

END