

Measurement of ethanol, formaldehyde and acetaldehyde from a flex-fuel vehicle exhaust over the WLTC

Ricardo Suarez-Bertoa¹, Michael Clairotte¹, Bertold Arlitt², Shigeru Nakatani³, Leslie Hill³, Klaus Winkler⁴, Charlotte Kaarsberg⁵, Thorsten Knaut⁵, Rens Zijlmans⁶, Henry Boertien⁶ and Covadonga Astorga¹.

¹European Commission Joint Research Centre Ispra, Institute for Energy and Transport, Sustainable Transport Unit, 21027 Ispra (VA), Italy.

²AVL Emission Test System GmbH, Instrumentation Test Systems, Max Roth Str. 1, 76571 Gaggenau.

³HORIBA Europe GmbH, Emission Engineering, Automotive Test Systems, Hans-Mess-Str. 6, 61440 Oberursel, Germany.

⁴IONICON Analytik GmbH, Eduard-Bodem-Gasse 3, 6020 Innsbruck, Austria.

⁵LumaSense Technologies A/S, Energivej 30, 2750 Ballerup, Denmark.

⁶Synspec BV, De Deimten 1, 9747 AV Groningen, the Netherlands.

KEYWORDS. Vehicle exhaust; diluted exhaust emissions; FTIR; PTR-Qi-ToF-MS; PAS; gas chromatography.

Abstract

An intercomparison exercise of the world-harmonized light-duty vehicle test procedure (WLTP) aiming at measuring ethanol, formaldehyde and acetaldehyde emissions from a flex-fuel light-duty vehicle using E85 at the dilution tunnel was conducted in the Vehicle Emission Laboratory (VELA) at the European Commission Joint Research Centre (EC-JRC), Ispra, Italy. All instruments participating in the intercomparison allowed *in situ* measurements of these compounds directly from the diluted exhaust, as it was established in the scope of this validation phase campaign. Measurements were done either in real time or immediately after the test. The measurement and analysis of exhaust emissions over the world-harmonized light-duty vehicle test cycle was done by means of Fourier transform infrared spectrometer (FTIR), proton transfer reaction-mass spectrometry (PTR-Qi-ToF-MS), photoacoustic spectroscopy (PAS) and gas chromatography (GC). The measured concentrations and the emission profiles revealed that all the used instruments are suitable to measure these compounds from the vehicle's exhaust ($|Z\text{-score}| < 2$). Results showed that online systems can perform measurements from the vehicle diluted exhaust assuring the reproducibility and repeatability of the results.

1. Introduction

Vehicular emissions significantly influence the composition of the atmosphere and have a strong impact on climate change [1]. The use of alternative fuels has been promoted in the European Union (EU) as a measure to decrease greenhouse gas (GHG) emissions and also to meet a growing demand of energy for transport use [2]. Biofuels have been seen as a measure to reduce emissions of GHGs from road transport because they were considered CO₂ neutral fuels. The EU has set a 10% renewable energy requirement for the transport sector, to be complied by 2020 (2009/28/EC) [3]. In 2010, the use of renewable energy by the transport sector was 4.70%, 91% of which was covered by biofuels [4]. In the United States, the Environmental Protection Agency (EPA) has implemented a series of initiatives to promote the introduction of renewable fuels, with a target of 136 billion liters of renewable fuel to be blended with gasoline by 2022 [5]. So far, ethanol is the main renewable fuel used for transportation in the US [6]. Blending mandates exist in 52 countries around the world having such requirements. China has a biofuels mandate of 10% by 2020. India, expects to cover 20% of its fuel demand with ethanol by 2017. Brazil, where ethanol has been used in different fuel blends since the mid-70s, mandates that 20% of the gasoline demand has to be supplied by ethanol by 2022. This target has already been reached [4].

In Europe, the latest version of the principle European gasoline (EN228) standards allows blending up to E10 (gasoline containing up to 10% of ethanol by volume). The high targets set on the use of renewable fuel will likely lead to a further increase of the ethanol concentration in gasoline. In fact, modern gasoline vehicles can already run on blends containing up to 15% of ethanol [7]. Since ethanol concentration in fuel blends is still an open issue, it is crucial to have a deep understanding of the impact that these plausible new fuels will have on vehicular emissions. Flex-Fuel Vehicles (FFVs) operate with standard gasoline and any ethanol containing blend. In Europe, FFVs can run on standard gasoline (hereinafter E5, gasoline containing 5% ethanol) or on blends of ethanol and gasoline containing up to 85% ethanol during the summer (E85) or 75% during winter (E75, winter blend).

Previous studies [8-11] have suggested that an increase in the ethanol content in the fuel blends reduces the emissions of some regulated gases (CO and total hydrocarbons (THC)) and CO₂. Those studies did not show strong trends for NO_x emissions. However, despite promising benefits in terms of reducing regulated compounds and CO₂

emissions, it has been shown that higher ethanol concentrations in fuel blends lead to higher emissions of formaldehyde and acetaldehyde [8-11]. These aldehydes are highly toxic and potentially carcinogenic [12-14]. They are also known for their impact on air quality, as they are precursors of ozone and peroxyacetyl nitrates (PAN) [15-17]. Therefore, given the current request to increase the ethanol concentration in motor fuel blends, it is crucial to study the emissions from FFVs for not only the regulated gases, but also the unregulated ones.

It has become necessary to find suitable techniques to measure ethanol, formaldehyde and acetaldehyde emissions from vehicle exhaust over the new World harmonized Light-duty vehicle Test Procedure (WLTP) that will be soon used for type approval of light-duty vehicles (LDVs) in the European Union and possibly other countries which are signatories to the United Nations Economic Commission for Europe (UN-ECE). Therefore, in the present study four different analytical techniques: High Resolution Fourier Transform Infrared spectrometry (FTIR), Proton Transfer Reaction-Mass Spectrometry (PTR-Qi-ToF-MS), photoacoustic spectroscopy (PAS) and gas chromatography (GC), present in six different instruments, were used to assess the feasibility of the measurement of ethanol, formaldehyde and/or acetaldehyde emissions from a FFV using E85 at the dilution tunnel over the Worldwide harmonized Light-duty driving Test Cycle (WLTC). These instruments were also compared to the United States and California Air Resources Board (CARB) conventional reference methods (Method 1001 for ethanol and Method 1004 for aldehydes).

2. Experimental and methods

A FFV was tested during the intercomparison exercise of the WLTP conducted in the Vehicle Emission Laboratory (VELA 2) at the European Commission Joint Research Centre (EC-JRC) Ispra, Italy. Six groups: AVL, HORIBA, Ionicon, LumaSense, Synspec and the Sustainable Transport Unit of the JRC, took part in the measurement and analysis of the exhaust emissions over the WLTC class 3, version 5.3 (see Figure 1 and Section 2.1). The technical description of the vehicle is available in Table 1. The vehicle was fuelled with E85 blend (85% vol/vol ethanol content, see Table 2 for fuel specifications).

The VELA 2 facility includes a climatic test cell with controlled temperature and relative humidity (RH) to mimic different ambient conditions (temperature range: -10 to 35 °C; RH: 50%). Triplicate tests were performed on a chassis dynamometer (inertia range: (454–4500) kg), designed for two and four-wheel drive LDV (two 1.22 m

roller benches – Maha GmbH, Germany). The emissions exhaust is fed to a CVS (HORIBA, Japan) using a critical Venturi nozzle to regulate the diluted exhaust flow rate (CVS flow range: 3 to 30 m³/min). A series of thermocouples monitored the temperature of the oil, cooling water, exhaust, and ambient conditions. The tests were conducted at test cell temperature of 23 ± 0.1°C, and at 50 ± 2% RH. The temperature refers not only to the cell temperature but also to the vehicle’s oil temperature, ± 1 °C, at the beginning of each test. Vehicle was kept inside the climatic cell under the described conditions for a 20-24 hours period, also known as soaking period.

Each instrument was independently calibrated “in-house” before joining the intercomparison campaign in Ispra. Their calibration was validated on-site using standards gases: ethanol (10 ppm and 100ppm in N₂) and formaldehyde (10 ppm in N₂). Acetaldehyde standard (25 ppm in N₂) could not be used because an impurity was detected in the gas bottle.

The detection limits of the involved gases (ethanol, formaldehyde and/or acetaldehyde) were calculated assuming 3 times the standard deviation of the background or zero air measured, with the exception of the PAS that was twice the noise signal on the measured concentrations when measuring in dry air.

Table 1. Vehicle specifications

Features	FFV
Combustion type	Spark Ignition
Year of registration	2012
EU emission standard	Euro 5
After-treatment	Three Way Catalyst
Fuel system	Direct Injection
Engine power (kW)	132
Engine displacement (cm ³)	1596
Vehicle total mass (kg)	2110
Odometer (km)	20010
Inertial class (kg)	1804

Table 2. Fuel specifications.

Parameter	Method	Unit	E85
RON ¹	ISO 5164	Index	107.3
MON ²	ISO 5163	Index	90.7
Density at 15 °C	EN ISO 3675-98	kg m ⁻³	782.3
DVPE ³ at 100 F	EN ISO 13016	mbar	464
Ethanol	EN ISO 13132	% v/v	84.1
Water	ASTM E 1064	% v/v	0.1
Sulphur (S)	EN ISO 20846	mg kg ⁻¹	<3.0
Carbon (C)	GC/calculated	mass %	57.0
Hydrogen (H)	GC/calculated	mass %	13.3
Oxygen (O)	GC/calculated	mass %	29.7

¹Research Octane Number; ²Motor Octane Number; ³Dry Vapor Pressure Equivalent.

2.1 Worldwide harmonized Light-duty vehicle Test Cycle (WLTC)

In 2009 a road map for a WLTP was proposed by the World Forum for Harmonization of Vehicles Regulations (WP.29) of the UN-ECE. Since the beginning of the WLTP process, the European Union had a strong political objective, set by its own legislation (Regulations (EC) 443/2009 and 510/2011) [18], to implement a new and more realistic test procedure. This was the major motivation to set the time frame of the whole WLTP and in particular of phase 1. The formal text for the phase 1a version of the light-duty vehicle Global Technical Regulation (GTR) was adopted by GRPE in 2013. The GTR specifies globally harmonized performance-related equipment specifications and test procedures. The phase 1a describes the development of the WLTC and associated test procedure for the common measurement of criteria compounds and CO₂.

Three different driving cycles were developed, on the bases of the vehicle's power-to-mass ratio and its maximum speed, to represent three different vehicle classes. The vehicle tested in the present study belongs to class 3 (power/mass >34 kW/ton and maximum speed >120 km/h), which is the highest power and speed class. Figure 1 illustrates the version 5.3 of the speed profile for this class.

The WLTC is a cold start driving cycle, where the vehicle and its components (oil, coolant, catalyst, etc) are at 23 °C at the beginning of each test. The driving cycle consists of four phases with different speed distributions (see Figure 1) and it intends to be representative of the real world driving conditions being based on real vehicle trips from several countries. The length of the entire cycle is 1800 seconds and is comprised of a low speed (589 s), medium speed (433 s), high speed (455 s) and extra-high speed (323 s) phase. Moreover, it reaches a maximum speed of 131.3 km/h and is 23.3 km long.

Figure 1. WLTC speed profile

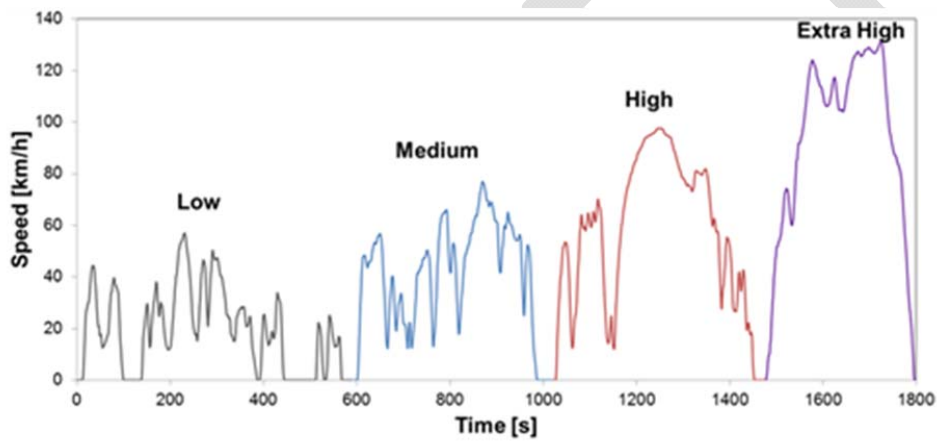

2.2 Analytical instrumentation

2.2.1 Regulated emission measurements

Although the scope of the campaign was to test the feasibility and quality of the measurements of ethanol, formaldehyde and acetaldehyde in the vehicular exhaust, regulated gases were also measured using standard methodologies defined by the related regulation to assure the performance of the vehicle used. CO, NO_x, THC and non-methane hydrocarbons (NMHC) are regulated for vehicle emission.

The CVS bag sampling method requires the collection of the diluted exhaust with a constant sampling flow rate from the dilution tunnel into a bag, thus, obtaining a representative sample of the total gas which passed through the dilution tunnel during the sampling period. Hence, a series of analyzers were connected to the exhaust bags. Once the sampling period was finished, the collected gas was drawn towards the corresponding analyzers. The regulated emissions from all vehicles were measured with a non-dispersive infrared (NDIR for CO/CO₂), a chemiluminescence (CLD for NO_x) and a heated (191 °C) flame ionization detector (FID for THC) (HORIBA, Japan) (see Figure 2).

Another set of analyzers, similar to the one used for gaseous regulated emission measurement, was directly connected at the tailpipe of the vehicle (see Figure 2). These sensors monitored online the dynamic volume concentration of the pollutants over the cycle driven, with 1 Hz frequency. This measurement methodology for the raw gas measurement is not indicated in the legislation; however, the outputs were mostly informative and useful in the framework of this project. Indeed, these comprehensive data were correlated with other dynamic parameters such as velocity of the vehicle, temperature of the exhaust gas, and instantaneous fuel consumption. The integration of the recorded signals provided valuable quality control information when compared with the emission factors resulting from the bags and they proved to be useful for the alignment of the FTIR signals (see FTIR-3 measurements). The volumetric flow rate of the exhaust (cubic meters per second) was determined by subtracting the variable dilution flow entering the tunnel to the constant total flow inside the tunnel. Mass of compounds were derived from the exhaust gas flow rates (cubic meter per second) and from the measured concentration (parts per million by volume).

Figure 2. Schematic diagram of the experimental setup.

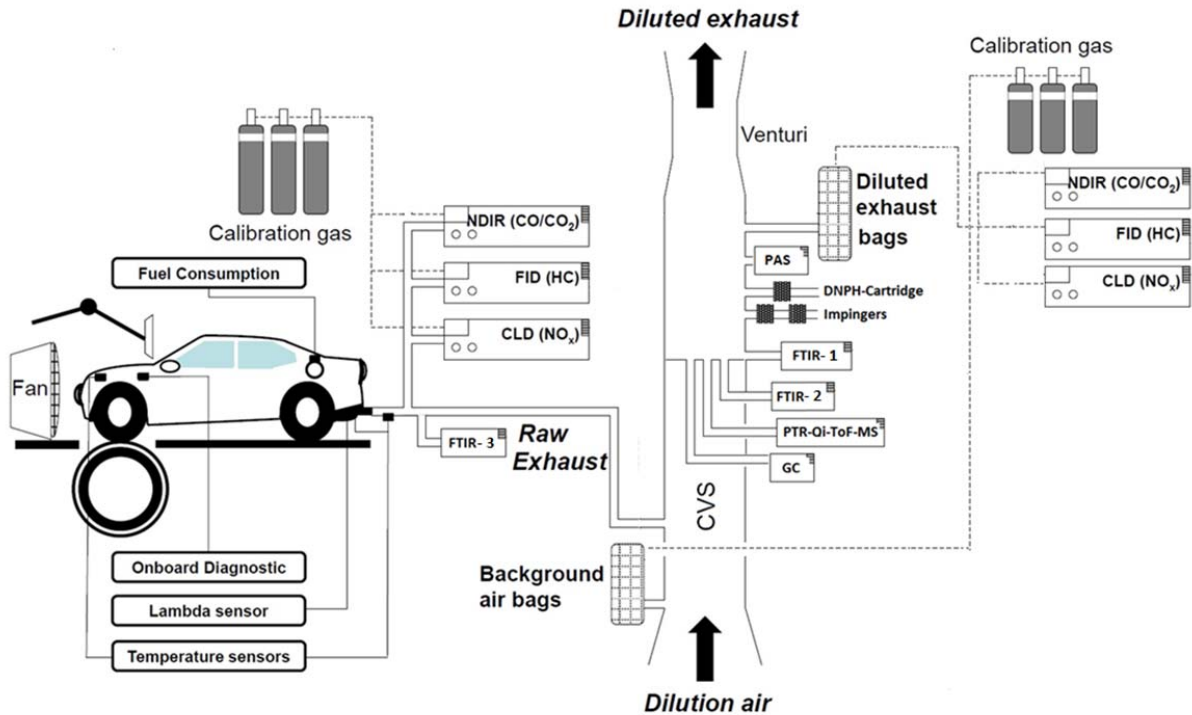

2.2.2 Method 1001: Sampling alcohols using impinger sampling system and GC analysis

Diluted exhaust was sampled at 4 l/min flow from the CVS using a heated-line set at 50 °C. The exhaust was sampled through two impingers, placed in series, which contained 15 ml of deionised water. The impingers were cooled using a cryogenic bath at ~0 °C. Sealed samples of each impinger were stored, in duplicated vials, at ~4 °C. The determination of ethanol in aqueous solution was performed by means of headspace gas chromatography and flame ionization detection at the TÜV laboratories. There, 5 ml of the sample was filled in a 20 ml headspace vial, together with 3 g of sodium chloride. After dissolving the sodium chloride, the vial was heated and ethanol was determined in the gas phase with gas chromatography and FID. Headspace and chromatographic conditions can be found in Annex I. The chromatographer's oven program was set at 40 °C during the first 9 min. Then, it was

increased 4 °C/min to 80 °C, followed by 10 °C/min to 230 °C. Finally, it was hold during 6 min at 230 °C. A column RTX-200: 60 m x 0,32 mm x 1 µm was used. Helium 5.0 grade was the carrier gas. A flow of 1.2 ml/min with a pressured of 10.7 psi were set during the analysis. The run lasted 40 minutes. The FID heater was set at 300 °C and H₂ and air flow were 30 ml/min and 400 ml/min, respectively.

After five samples were measured, an independent controlling standard was determined. The controlling standard was also a solution of ethanol in water. The system calibration was done following the same protocol, using 6 external calibration standards. The retention time of ethanol under the described conditions was 7.3 min. The detection limit was 0.5 mg/l and the measurement uncertainty 3.0%.

2.2.3 Method 1004: Sampling aldehydes using DNPH cartridges and HPLC-UV analysis

Diluted exhaust was sampled through a DNPH-cartridge at 1 l/min flow from the CVS using a heated-line set at 50 °C. The sealed DNPH-cartridges were stored at ~4 °C. The determination of formaldehyde and acetaldehyde in DNPH cartridges was obtained by means of high pressure liquid chromatography (HPLC) with UV-DAD detection also performed at the TÜV laboratories. The cartridge containing the 2,4-dinitrophenylhydrazine derivative of formaldehyde and acetaldehyde was eluted with 2 ml of acetonitrile. The eluate was measured with HPLC-UV-DAD. 10 µl of sample were injected in a column Macherey & Nagel EC 250/4.6 Nucleodur 100/5 C18ec, reversed phase. The column length was 250 mm with an internal diameter of 4.6 mm and a particle size of 5 µm. The column temperature was 45 °C. A gradient of water and acetonitrile was used with a 2 ml/min flow. The UV detection was at 365 nm.

The calibration was done with external calibration standards of the DNPH derivatives. The concentration of the calibration standards (aldehydes in acetonitrile) are shown in Annex I. Determination limit was 0.1 µg/probe and the measurement uncertainty 6.4%. An independent controlling standard was determined on daily bases. The controlling standard was a solution of 2 mg/ml of formaldehyde in acetonitrile, which was transferred in the DNPH-derivative.

2.2.4 FTIR-1; AVL SESAM i60 FT SII (dilute exhaust measurement)

The AVL SESAM i60 FT SII is a multi-component automotive exhaust gas analysis system, based on a spectroscopy analyzer. It utilizes an AVL FTIR i60 spectrometer with the high spectral resolution of 0.5 cm^{-1} for fast transient gas phase analysis. The FTIR uses a silicon nitride (Si_3N_4) IR and a photoconductive MCT (HgCdTe) detector. The sample gas cell is an optimized, multi-reflection design with an optical path length of 3.2 m. The FTIR spectrometer is calibrated by generating a pure component spectra library of all gases and vapors over several possible concentration ranges expected in several sample gas variations during the automotive emission test cycle. The intensity of the absorption bands correlates with the sample gas concentration according to Beer's law equation. By the usage of dedicated software programs, the pure component spectra with known reference concentration are used to set up a matrix evaluation method that has been developed for the quantitative analysis of automotive exhaust emissions. The software calibration model is setup to be used by the Classical Least Squares (CLS) algorithm, which allows for rapid calculation of diverse species concentrations, even at existing overlap of spectral features in the sample gas mixture.

The SESAM i60 FT SII system has an air jet pump that feeds the sample gas with a controlled 8 l/min flow through the gas cell of the FTIR spectrometer, which analyzes the sample gas with 5 Hz real-time modulation scan rate. To avoid exhaust condensation, the sampling system including filter, sample gas transfer lines and gas cell are heated to a temperature of $50 \text{ }^\circ\text{C}$. The system is optimized to generate good detection limits with a system response time of 2 s for the time synchronized measurement of CVS diluted automotive exhaust. The detection limits of the involved gases (ethanol, formaldehyde and acetaldehyde) were calculated assuming 3 times the standard deviation of the reading of each compound using zero air over 60 sec. The value expressed as LoD concentration are respectively 0.15 ppm for formaldehyde, 0.5 ppm for acetaldehyde and 0.3 ppm for ethanol.

2.2.5 FTIR-2; HORIBA MEXA-FT (dilute exhaust measurement)

MEXA-FT-dilute was a prototype modified FTIR for diluted exhaust. It applied the FTIR for obtaining an infrared absorption spectrum of high resolution by a combination of an interferometer and high-speed Fourier transformation. Since lots of compounds have their unique spectrum in the infrared region, this method is used for quantitative and qualitative determination in various fields. The analyzer is designed for the continuous dilute

measurement of the concentration of components included in engine emissions. MEXA-FT-dilute combines the FTIR technology and multivariate calculation for the simultaneous concentration analysis of multiple components. The analyzer allows measurement of up to 24 components from gasoline and diesel engines, as well as CNG engines.

Infrared light radiated from a light source becomes an interference light, passes through a cell in which the sample gas is flowing, and then enters a detector. The cell is kept at constant temperature of 53°C to ensure steady conditions during the entire measurements. The infrared light is reflected multiple times inside the cell to reach a total length of 10 m which provides high sensitivity for dilute measurements and the ability to detect low to ultra-low concentrations.

The spectrum of the infrared light that passed the cell (power spectrum) can be estimated by converting the signal obtained here (interferogram) by means of fast Fourier transformation. For qualitative and quantitative analysis, the power spectrum, in a case where zero gas (nitrogen gas) is flowing in the cell, is separately measured, and the infrared absorption spectrum for the sample gas is calculated from the proportion of both spectra. In MEXA-FT-dilute, concentration values for contained multiple components are calculated simultaneously by adopting a multivariate analysis technique to this spectrum.

The FTIR method has a feature where H₂O can be measured simultaneously and an emission gas sample containing high-concentration water can be introduced to the cell. Thus, soluble components such as ethanol and formaldehyde that would be removed by dehumidifying the sample can be measured. The components measured by the MEXA-FT-dilute can be selected in accordance to the composition of the sample gas.

The exhaust gas is sampled at a flow rate of 5 l/min from a dilution tunnel. It is then supplied to the analyzer via an approx. 2 m long PTFE tube and the real-time spectra are collected every 1 sec. The limit of detection for ethanol, formaldehyde and acetaldehyde were 1.5, 1.1 and 0.6 ppm, respectively. The accuracy was better than 1.0 ppm for all the compounds analysed.

2.2.6 PTR-Qi-ToF-MS (dilute exhaust measurement)

Proton transfer reaction-mass spectrometry, PTR-MS, is a technique based on soft chemical ionization via proton transfer for the detection of volatile organic compounds, VOCs. The operating principle of PTR-TOF-MS in terms of the ionization of neutral analytes is depicted in Figure 3. The system comprises a front-end ion source, a hollow cathode discharge source, to produce hydronium ions, H_3O^+ , i.e. protonated water, from a continuous flow of water vapour that is fed into the ion source. The reagent hydronium ions are transferred to a reaction chamber (drift tube) in which sample gas containing the volatile target molecules is directly introduced. These neutral molecules become ionized via proton transfer upon ‘collision’ with the hydronium ions, provided the conditions are energetically favourable for such reactions. A particular advantage of this protonation reaction is that it proceeds at the collisional rate and at relatively low energy, thus the fragmentation of the neutral target is limited and invariably the quasi-molecular parent ion, i.e. MH^+ , is generated.

Figure 3. Schematic diagram of the PTR-TOFMS instrument consisting of a hollow cathode ion source, a (flow) drift tube, and a detection system comprising a transfer lens system and a time-of-flight, TOF, chamber. © IONICON Analytik GmbH

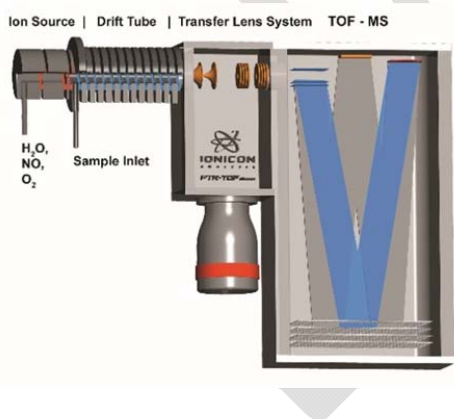

At the downstream end of the drift tube the protonated analytes and precursor ions are transferred into the detection system. Upon entering the ToF region the ion swarm is given a transverse electronic impulse – or more accurately, rapid, successive pulses at $\sim 30 \mu\text{s}$ intervals – to inject or ‘shoot’ a cluster of ions into the flight chamber. The cluster moves in this field-free region with its initial axial momentum and the additional transverse momentum received by the electronic impulse, and is only reflected and refocused at the far end of the chamber by a reflector,

thus describing a v-shaped path. After reflection the swarm returns to the axial position where the individual ions are detected by a multichannel plate, MCP.

The PTR-ToF-MS was operated at the following parameters: a drift pressure of 4.0 mbar and a drift voltage of 800V, the E/N-ratio was 120 Townsend. After an initial test with different drift voltages, this voltage was chosen for a good sensitivity for the measured compounds. The temperature of the reaction chamber was kept at 80 °C. The sample gas inlet line connecting the PTR-MS was also heated to 80 °C. The sampling frequency was set to 1 Hz, i.e. a full mass spectrum from m/z 1 to 500 Th in every second.

By using a sample gas dilution the range for linear signal response in the PTR-MS (normally ~ 10 ppt to 10 ppm) can be shifted upwards to optimize for the current conditions. For the measurements performed in VELA a dilution with 500 sccm of clean N₂, resulting in a dilution ratio of 67:500 (x 8.4), was used.

All data have been processed according to standard practice in PTR-MS measurements, i.e. the raw data have been normalized to 1 million cps (counts-per-second) of primary ions (H₃O⁺, actual number of primary ions ~ 30 million cps), resulting in instrument-independent “normalized counts-per-second” (ncps). The instruments sensitivity, determined in calibration experiments, has been used to convert measured signals in units of parts-per-million (ppmv). Therefore a correction for the instruments transmission function was not necessary. The dilution factor has been accounted for to get the undiluted concentrations in the gas streams. As a final step, the concentrations were converted into mass/time (g/s), knowing the gas flow through the constant volume tube (about 8.88 m³/min).

We have performed regular measurements of the background. This background has been subtracted. Negative values after background subtraction were set to zero in the data sets. The experimentally determined “Method LoD”, which includes all possible noise sources and reflects the whole setup, was calculated from 3 times the standard deviation of the zero signal of the corresponding compounds. LoD was about 5 ppbv for formaldehyde, 2 ppbv for acetaldehyde and 30 ppbv for ethanol.

2.2.7 Photoacoustic gas monitor (dilute exhaust measurement)

The photoacoustic effect is the emission of sound from an enclosed gas sample absorbing chopped infrared light. The type of light source most suited to gas detection and analysis is one that emits radiation in the infrared region between 650 and 4000 cm⁻¹. An excellent and more dependable alternative to sunlight is an incandescent source, a

wire filament heated to a high temperature. The spectral output is continuous, with 70-80% of it in the infrared region. Narrow bandwidth radiation is required for spectroscopy and optical filters with a fixed bandwidth are used in conjunction with the infrared light source.

When a gas is irradiated with light, it absorbs some of the incident light energy. The amount of energy it absorbs is proportional to the concentration and the absorbed light energy is immediately released as heat and this causes the pressure to rise. When the light is modulated at a given frequency, the pressure increase is periodic at the modulation frequency and the sound waves are picked up by microphones.

Figure 4 illustrates the measurement system in the gas monitor INNOVA 1412i/1314i/3433. An air sample is drawn into the measurement chamber and the chamber is sealed by the valves. Then, radiation from the IR-source passes through a chopper and optical filter into the chamber. The IR radiation is absorbed and generates heat and pressure variations. These pressure variations correspond to the chopper frequency, creating a pressure wave which is detected by the microphones. Finally, the microphone signal, proportional to the gas concentration, is post processed and the measurement result is calculated.

The main goal during the measurement task was the measurement of ethanol. Additional filters for formaldehyde and acetaldehyde have been installed for testing purposes only. Ammonia and CO₂ filters were installed for cross compensation. The used filter UA0974 has a detection limit of 0,08 ppm for ethanol at SIT = 5 s. Longer SIT's result in lower detection limits. During all tests at the JRC, measurements were performed with SIT = 5 s. Ethanol calibration at LumaSense was performed with a 98 ppm calibration gas mixture, 2 % accuracy.

The ethanol measurements were performed with samples from CVS bags after each test cycle. The concentration readings in ppm's were corrected to JRC's 100 ppm ethanol calibration gas and finally converted to emission factors in mg/km.

Figure 4. Photoacoustic gas monitor schematics.

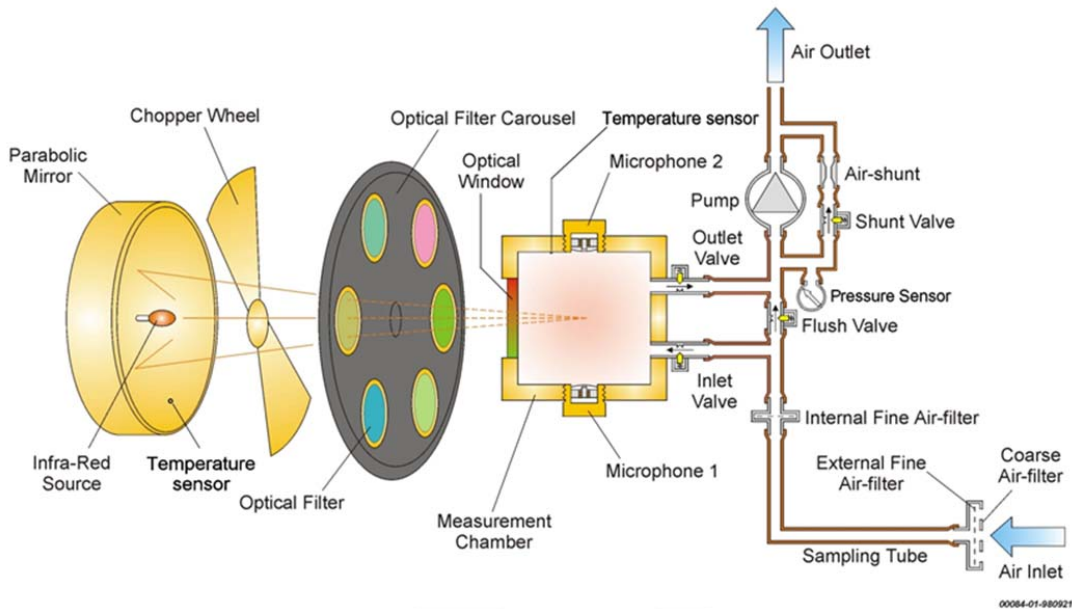

2.2.8 Synspec gas chromatograph double system (dilute exhaust measurement)

A continuous GC system (GC955 from Synspec BV) was prepared to determine the total emitted acetaldehyde and ethanol from a car exhaust pipe, by analyzing the diluted exhaust gas in a CVS. The VOCs in the sample gas are collected on the trap in the GC during a time interval of five minutes and are subsequently injected into a chromatography column by using nitrogen as carrier gas. A clear separation of the components in the sample gas is performed within five minutes and ethanol and acetaldehyde are detected by a photo ionization detector (PID). By combining two similar GC systems, the cumulative emission during the complete test protocol is determined.

The measurement was performed in four phases, a 10-port valve is used to switch the gas flow direction through the analyzer between these phases. The key elements of the connections and configuration of the two GC's (GC-1 and GC-2) are sketched in Figure 5. In the first phase, the sample gas is collected on Tenax GR 60/80 in the trap by using a sample cylinder with piston that sucks a pre-determined amount of sample gas. A total sample gas volume of 5.5 ml is collected in 5 minutes. In the second phase, the collected sample is injected into the stripper column by switching the 10-port valve and pushing the sample gas with 1.5 ml/min carrier gas (nitrogen). When the sample gas

leaves the stripper column, it is directed further into the analysis column and towards the detector. In the third phase, a backflush is performed. As soon as the gases of interest are present on the analysis column, the 10-port valve is switched again and the sample gas is pushed further towards the detector. Simultaneously the gas flow through the stripper column is reversed (backflush) in order to clean the stripper column and to assure a short cycle time in the GC. The sample pump integrated in GC-2 (NMP 830 KNDC from KNF with a capacity of 3.1 l/min) flushes the sample lines continuously.

The two systems are prepared to measure both ethanol and acetaldehyde with a PID and in addition, GC-2 is equipped with an additional FID. The sample gas is injected into the PID after it leaves the analytical column. Subsequently, the sample gas can be directed into the FID. The signals from the PID and FID are recorded as a function of time. Typical measurements from GC-1 are shown in Figure 6. The blue and purple peaks in these figures indicate the peaks that are automatically analyzed as acetaldehyde and ethanol respectively. Calibration is performed by evaporating ethanol and acetaldehyde and diluting it with nitrogen to a concentration in the range: 0 - 5 ppm and validated on-site with 100 ppm ethanol in pure nitrogen. The raw output of the GC's is the time weighted average of the concentration of acetaldehyde and ethanol over the sampled time interval, which is available in units of $\mu\text{g}/\text{m}^3$. The limit of detection for ethanol and acetaldehyde were 3 and 4 ppb, respectively.

Figure 5. Sketch of double Gas Chromatography system, GC-1 (SN #2773), GC-2 (SN #2988)

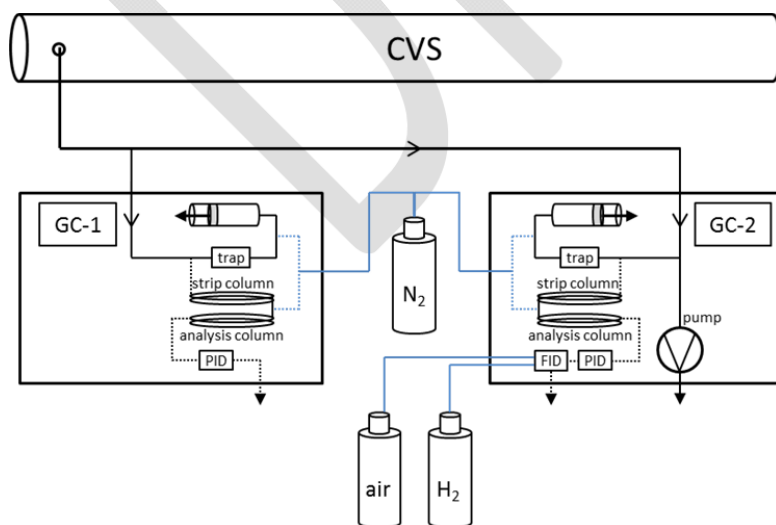
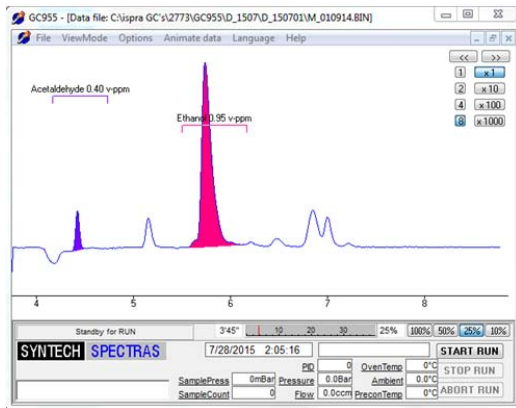

Figure 6. Typical measurement during from CVS using GC-PID



2.2.9 FTIR-3 spectrometer for to automotive emission (raw exhaust measurement)

A High Resolution Fourier Transform Infrared spectrometer (FTIR – MKS Multigas analyzer 2030-HS, Wilmington, MA, USA) allowed measuring the concentration of up to 20 exhaust compounds by a multivariate calibration based on a factory developed model. Implementation of the FTIR spectrometer for exhaust gas measurement required the acquisition of an averaged background spectrum from N₂. This daily background spectrum was systematically subtracted to the new spectra registered by the instrument. The calibration of the instrument was based on a factory developed multivariate model. CO, CO₂ and NO_x measurements from the previously described analyzers were used to check the FTIR calibration model. The limit of detection for ethanol, formaldehyde and acetaldehyde was estimated with the values obtained from the measurement of the background air, by assuming 3 times the standard deviation of the measured value to the averaged value. The limit of detection for ethanol, formaldehyde and acetaldehyde were found to be 3, 0.7 and 2 ppm.

FTIR spectrometers dedicated to real time analysis of automotive emission must have a high acquisition frequency in order to register fast changes of volume concentration resulting from sharp accelerations. The output signal can be used to monitor the fluctuation of pollutant emission along the speed profile. Furthermore, the CO and/or NO signals were precisely synchronized using the CO or NO_x instantaneous measurement at the tailpipe

obtained using the non-dispersive infrared (NDIR) or the chemiluminiscence detector (CLD), respectively, so that all instruments would align to the very same time.

The JRC FTIR (Multigas analyzer 2030 HS - MKS, Wilmington, MA) reached 5 Hz acquisition frequency with a multipath gas cell of 5.11 m. It is equipped with a Michelson interferometer (spectral resolution: 0.5 cm^{-1} , spectral range: $600\text{-}3500\text{ cm}^{-1}$) and a liquid nitrogen cooled mercury cadmium telluride detector. The raw exhaust was sampled directly from the vehicle's tailpipe with a PTFE (politetrafluoroetilene) heated line and a pumping system (flow: ca. 10 l min^{-1} , T: $191\text{ }^{\circ}\text{C}$) in order to avoid the wall adsorption and/or dissolution of hydrophilic compounds (i.e. NH_3 , NO_2 , aldehydes, or ethanol) in condensed water. The residence time of the raw exhaust gas in the heated line before the FTIR measurement cell was less than 2 seconds. The measurement temperature was set to $191\text{ }^{\circ}\text{C}$, with a working pressure of 1013 hPa (± 20). The compounds were monitor at 5 Hz, averaged and presented at 1 Hz.

Table 3. Summary of the main features of the techniques used for this intercomparison exercise.

	Technique	Sampling flow (l/min)	Analysis Frequency and Response	Sampling Temp ($^{\circ}\text{C}$)	Cell/chamber Temp ($^{\circ}\text{C}$)	Additional Pollutant measured
AVL SESAM i60 FT SII	FTIR-1	8	5 Hz	50	50	EtOH, HCHO & CH_3CHO
HORIBA MEXA-FT	FTIR-2	5	1 Hz	r.t.	53	EtOH, HCHO & CH_3CHO
IONICON	PTR-Qi-ToF-MS	0.067	1 Hz	80	80	EtOH, HCHO & CH_3CHO
LumaSense	PAS	0.2	$\leq 60\text{ s}^*$	r.t.	$\sim 40^{\circ}\text{C}$	EtOH
Synspec	GC	1.1**	5 min	r.t.	-	EtOH & CH_3CHO
JRC MKS	FTIR-3	10	5 Hz	190	190	EtOH, HCHO & CH_3CHO
CARB Method 1001	Impinger/ GC-FID	4	Off-line	50	-	EtOH
CARB Method 1004	Cartridge/ HPLC-UV	1	Off-line	50	-	HCHO & CH_3CHO

*PAS measured from a bag once the test was finished; ** 5.5 l sampled every 5 minutes.

2.3 Statistical analysis

The assessment of measurements for ethanol, formaldehyde and acetaldehyde using online and/or *in situ* analytical methods for the WLTP as an alternative to the conventional reference methods (see above CARB Methods 1001 and 1004) was done through consecutive statistical analysis.

In a first stage, the performances obtained with each instrument were compared (see Figure 7 and Figure 8). The assigned values of ethanol, formaldehyde and acetaldehyde were calculated using the averaged values obtained from all instruments capable to measure the specific compounds. In other words, assigned values were consensus values derived from the results obtained from all instrument. Each instrument performance was assessed using the Z-score as performance indicator:

$$Z - score = \frac{x_i - X}{s} \quad (1)$$

where x_i and X stand for the mean of the instrument and the consensus value, respectively. s stands for the standard deviation of the consensus value (ISO 17043) [19]. Instrument performance was considered satisfactory when absolute value of Z-score was lower than 2, questionable when between 2 and 3, and unsatisfactory when higher than 3.

In a last stage, calculations of repeatability (s_r) and reproducibility (s_R) of the intercomparison exercise were carried out on those results remaining after the removal of variance and average outliers, as defined by the ISO 5725-2 [20]. Variance outliers were identified based on within-instrument variance using a Cochran test (1% critical value). Average outliers were identified based on between-instrument variability using a Grubbs test (1% critical value). The overall repeatability was calculated using the following formula:

$$s_r = \sqrt{\frac{\sum_{i=1}^p [(n_i - 1)s_i^2]}{\sum_{i=1}^p (n_i - 1)}} \quad (2)$$

where n_i stands for the number of measurement achieved by instrument i , s_i the standard deviation of instrument i , and p the number of instrument after outlier removal. The overall reproducibility was calculated using the following formula:

$$s_R = \sqrt{s_f^2 + s_L^2} \quad (3)$$

Where s_L^2 stands for the between-instrument variance, calculated using the formula:

$$s_L^2 = \frac{\frac{1}{p-1} \sum_{i=1}^p [n_i(x_i - \bar{x})^2] - s_f^2}{\bar{n}} \quad (4)$$

Where \bar{x} stands for the average of the means of the non-outlier instruments, and \bar{n} defined as:

$$\bar{n} = \frac{1}{p-1} \left[\sum_{i=1}^p n_i - \frac{\sum_{i=1}^p n_i^2}{\sum_{i=1}^p n_i} \right] \quad (5)$$

More details regarding outlier identification as well as calculation of repeatability and reproducibility of the intercomparison exercise can be found in the ISO 5725-2 standard.

3. Results and discussion

3.1 Regulated compounds

The quantification of the regulated compounds (CO, NO_x, THC and NMHC) emitted is of major interest for the assessment of the performance of the tested vehicle. The regulated emissions were measured according to the new GTR. Average emission factors of the regulated compounds from the three performed tests were below Euro 5 emission standard (see Table 4).

Table 4. Regulated emissions (mg/km); (*g/km). Errors refer to the standard deviation of the three performed tests.

	THC	NMHC	CO	NO_x	CO₂*
Phase 1	172±17	127±11	588±154	52±3	258.2±0.9
Phase 2	4±1	2.1±0.4	117±82	14±2	186.9±0.4
Phase 3	1.8±0.5	1.0±0.2	110±35	9±1	170.3±0.3
Phase 4	18±1	7.8±0.6	931±226	23.1±0.6	210±1
WLTC	31±2	20±1	466±36	20.8±0.6	199.5±0.5

Measurement of regulated compound emissions showed very good repeatability with a coefficient of variation below 8% (see Table 4), demonstrating the suitability and precision of the testing procedure. Regarding CO₂ emission, the repeatability was even better, with a coefficient of variation below 0.5%. An example of the repeatability for CO₂, oil temperature and exhaust temperature can be seen in Figure 9.

Figure 9. Illustration of some signals measured (exhaust temperature, CO₂ emissions, oil temperature) and repeatability for the three tests performed for the FFV over the WLTC.

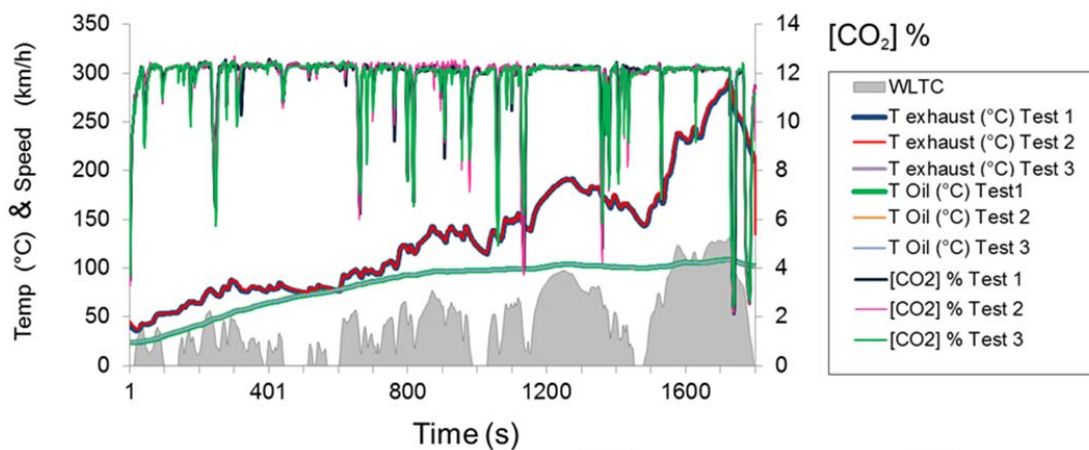

3.2. Unregulated compounds: ethanol, formaldehyde and acetaldehyde emissions and measurements

Average emission factors from the FFV tested using E85 over the WLTC are summarized in Table 5. These averages were obtained from the three tests performed (one per day / cold start) and the errors refer to the standard deviation of the three repetitions.

Table 5. Ethanol (EtOH), acetaldehyde (CH₃CHO) and formaldehyde (HCHO) emission factors (mg/km) over the WLTC. The errors refer to the standard deviation of the three repetitions.

	Sampling*	EtOH	CH ₃ CHO	HCHO
FTIR-1	CVS	17±4	5.4±0.4	1.1±0.1
FTIR-2	CVS	16±2	5.2±0.3	0.8±0.2
PTR-Qi-ToF-MS	CVS	17±3	5.4±0.2	1.0±0.1
PAS¹	CVS	16±1	-	-
GC²	CVS	14±2	5±1 [°]	-
FTIR-3	TP	17±2	5.3±0.6	1.1±0.1
Cartridges + HPLC-UV (CARB 1004)	CVS	-	4.6±0.3 [□]	1.2±0.1
Impingers + GC-FID (CARB 1001)	CVS	16±2	-	-
Assigned value (mg/km)		16.2	5.2	1.0
Repeatability (%)		14	12	13
Reproducibility (%)		14	12	19

*Sampling points: CVS dilution tunnel; TP tailpipe. ¹ photoacoustic spectroscopy; ² double GC system. Statistical analysis: [°] variance straggler (Cochran's test with 5% critical value), [□] average straggler (Grubbs' test with 5% critical value).

3.2.1. Ethanol emissions and measurement

During the campaign, four instruments (FTIR-1, FTIR-2, PTR-Qi-ToF-MS and GC) worked online sampling from the CVS. The FTIR-1, FTIR-2 and the PTR-Qi-ToF-MS were capable of providing real-time data (see Figure 10 and Figure 11). The photoacoustic system sampled from a Tedlar bag containing diluted exhaust sampled from the CVS during the tests. Sampling with impinges and GC-FID analysis (CARB Method 1001) was the reference analytical method for ethanol. The obtained ethanol emission factors are shown in Table 5. As illustrated in Figure 10 and Figure 11 ethanol emissions were significantly higher until the catalyst reached the optimal working conditions. Once the catalyst reached the optimal operating temperature, the ethanol emissions decreased substantially and, in some cases, under the limits of detection of the used instruments. The Figures show that ethanol

was mainly emitted during the Phase 1 of the WLTC. Figure 11 illustrates that the obtained ethanol emission profiles were consistently and evenly reproduced by the three analytical instruments, FTIR-1, FTIR-2 and PTR-Qi-ToF-MS. It also shows that the profile obtained using the FTIR-3, was in good agreement with those sampling at the CVS. The PTR-Qi-ToF-MS measured ethanol real-time emissions that were slightly higher than those reported from the other instruments. FTIR-2 showed a lower time resolution, resulting in lower emissions with a longer emission time profile. It must be noticed that besides these differences, the total emissions measured by the instruments were in very good agreement (see Table 5).

First stage of statistical analysis was applied and Z-score performance indicators were computed considering the assigned value of ethanol as the consensus value provided by all instruments (16.2 mg/km, Figure 7). Based on the Z-score, performances of all the instruments were considered satisfactory ($|Z\text{-score}| < 2$).

No variance outlier was identified through the last stage of statistical analysis (Cochran's test with 1% critical value). No variance straggler was identified either (Cochran's test with 5% critical value). This means that within-instrument repeatability was in the same order of magnitude for each instrument. Regarding average outlier identification, neither outlier (Grubbs' test with 1% critical value), nor stragglers (Grubbs' test with 5% critical value) were identified. The repeatability obtained for ethanol measurement was 2.2 mg/km.

Finally, the overall ethanol reproducibility of the intercomparison exercise, including within-instrument and between instrument variances, was 2.2 mg/km. In this case, reproducibility was equal to repeatability (14%). Between-instrument variance (s_L^2 in equation 4) was found negative. Consequently, as specified by ISO 5725-2, between instrument variance was set to zero (in equation 3).

Considering the variety of technics/detectors used, the different temperatures and sampling points, and the inherent variability associated to the vehicle tested, it can be stated that ethanol measurement was achieved with an excellent repeatability and reproducibility during this intercomparison exercise.

Figure 7. Z-scores obtained for the seven instruments capable of monitoring ethanol emissions

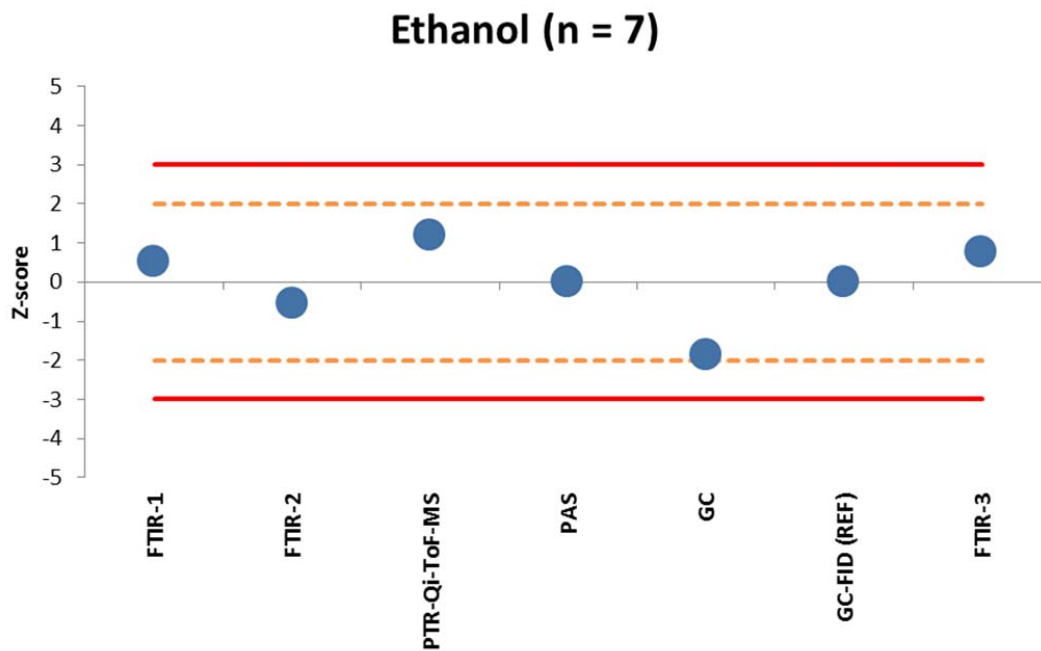

3.2.2 Formaldehyde and acetaldehyde emissions and measurement

Acetaldehyde and formaldehyde average emission factors are shown in Table 5. Sampling through a DNPH cartridge and HPLC-UV analysis (CARB Method 1004) was the reference analytical method for formaldehyde and acetaldehyde. Four online instruments (FTIR-1, FTIR-2, PTR-Qi-ToF-MS and GC) measured acetaldehyde sampling from the CVS. Only FTIR-1, FTIR-2 and PTR-Qi-ToF-MS measured formaldehyde. The FTIR-1, FTIR-2 and the PTR-Qi-ToF-MS were again capable of providing real-time data for the two aldehydes (see Figure 10 and Figure 11). The presented average emission factors were obtained from the three performed tests and the errors refer to the standard deviation of the three repetitions (Table 5). Figure 10 and Figure 11 illustrate that, as in the case of ethanol, acetaldehyde and formaldehyde emissions were very high until the catalyst light-off. Then, these emissions decreased. Figures also show that acetaldehyde and formaldehyde emissions took place during the Phase 1 of the WLTC. Figure 11 illustrates that the obtained acetaldehyde and formaldehyde emission profiles were consistently and evenly reproduced by FTIR-1, FTIR-2 and PTR-Qi-ToF-MS. It also shows that the profile obtained using the FTIR-3, which measured from the tailpipe, was in good agreement with those sampling at the CVS. While the PTR-

Qi-ToF-MS and the FTIR-1 resulted in very similar real-time acetaldehyde and formaldehyde emissions, the FTIR-2 presented lower emissions with a longer emission time profiles due to a lower time resolution. Nonetheless, the total emissions measured using all instruments were in very good agreement.

First stage of statistical analysis was applied and Z-score performance indicators were computed considering the assigned value of acetaldehyde and formaldehyde as the consensus of all values obtained (5.2 mg/km and 1.0 mg/km for acetaldehyde and formaldehyde, respectively). Based on the Z-scores, performances of all methods were considered satisfactory for both acetaldehyde and formaldehyde measurement ($|Z\text{-score}| < 2$) (see Figure 8a and 8b for acetaldehyde and formaldehyde, respectively).

No variance outlier was identified for acetaldehyde and formaldehyde (Cochran's test with 1% critical value). However, the measurement of acetaldehyde with the GC instrument (double GC system) was identified as variance straggler (Cochran's test with 5% critical value). Despite this variance straggler, it can be stated that within-instrument variance was equivalent among the instruments for formaldehyde measurement, and almost equivalent for acetaldehyde measurement. No average outlier was identified for acetaldehyde and formaldehyde (Grubbs's test with 1% critical value). However, acetaldehyde average from the Cartridge + HPLC-UV method (CARB Method 1004) was identified as a straggler. The repeatability obtained for acetaldehyde and formaldehyde measurements were 0.6 and 0.13 mg/km, respectively. Finally, the overall acetaldehyde and formaldehyde reproducibility of the intercomparison exercise, including within-instrument and between-instrument variances, were 0.6 and 0.2 mg/km, respectively. In the same way as for ethanol measurement, acetaldehyde between-instrument variance was found negative and set to zero as specified by ISO 5725-2.

Repeatability of acetaldehyde and formaldehyde measurement represented less than 13% of the assigned value. Considering the inherent variability associated to the vehicle tested, such repeatability can be considered excellent. In addition, the overall reproducibility represented 12% and 19% of the assigned value for acetaldehyde and formaldehyde measurements, respectively. Considering the variety of technics/detectors used, the different temperatures and sampling points, and the rather low emissions of these aldehydes (especially those of formaldehyde), it can be stated that acetaldehyde and formaldehyde measurements were achieved with an excellent reproducibility during this intercomparison exercise.

Figure 8 a-b. Z-scores obtained for the instruments capable of monitoring (a) acetaldehyde and (b) formaldehyde emissions

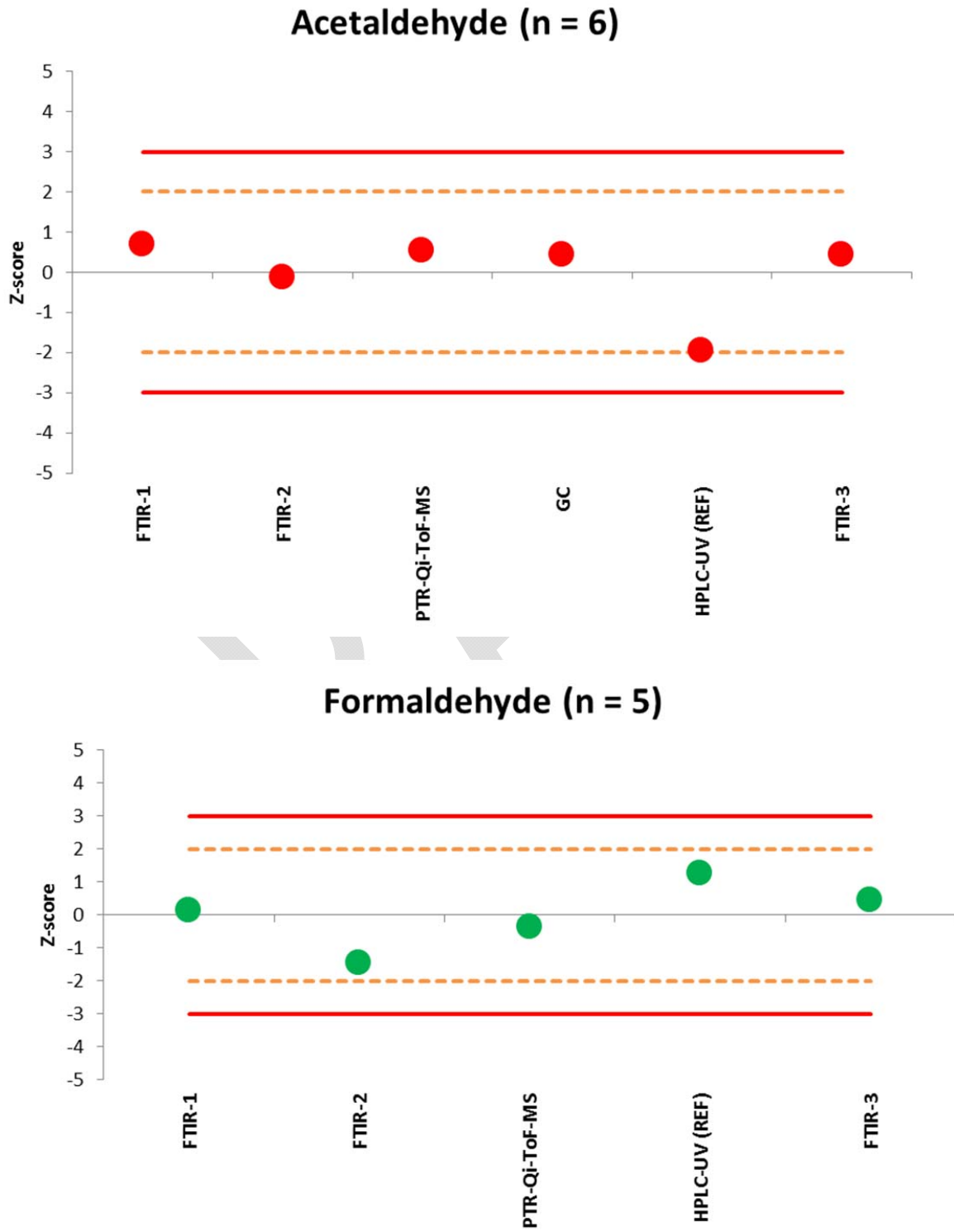

Figures 10 a-d. Online emission profiles of EtOH (purple), CH₃CHO (red), HCHO (green) measured at the CVS from the tailpipe over the WLTC. In the inner plot a close-up of the first 200 seconds.

a) FTIR-1 at the CVS

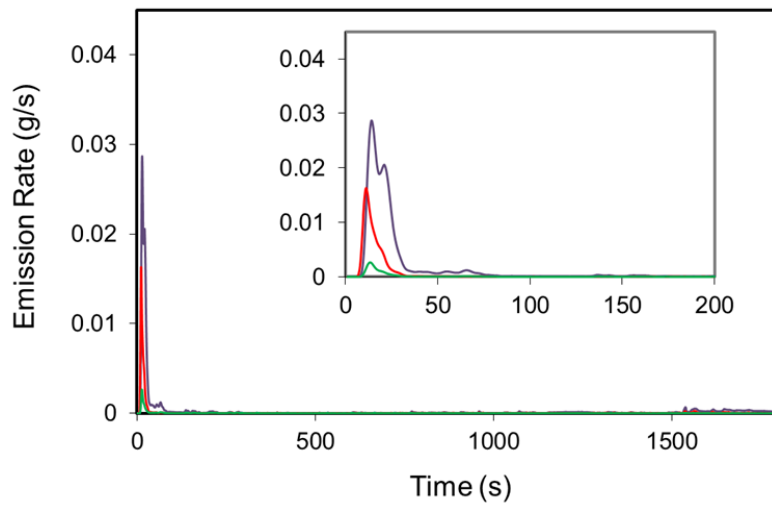

b) FTIR-2 at the CVS

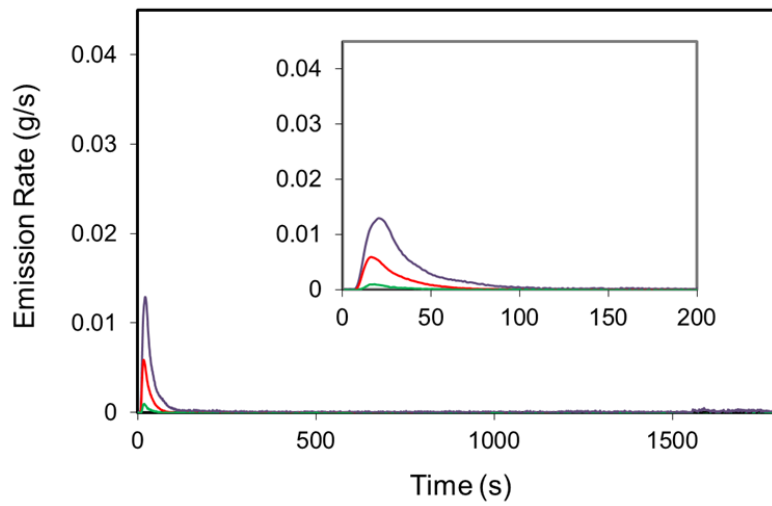

c) PTR-Qi-ToF-MS at the CVS

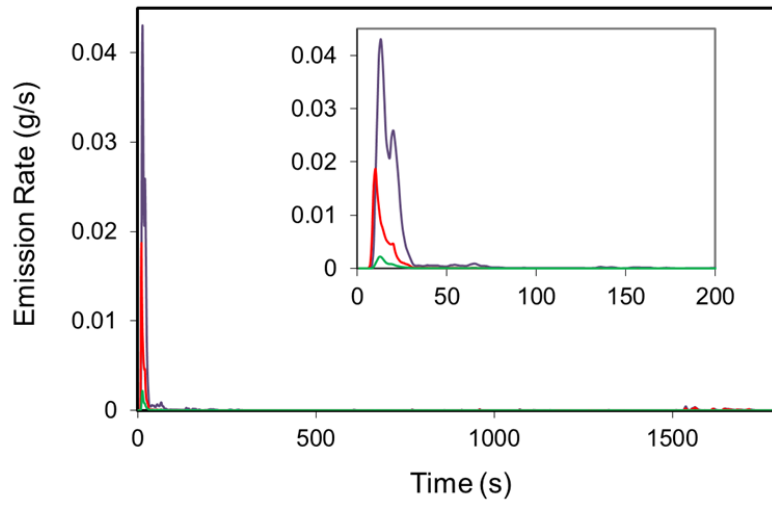

d) FTIR-3 at the tailpipe

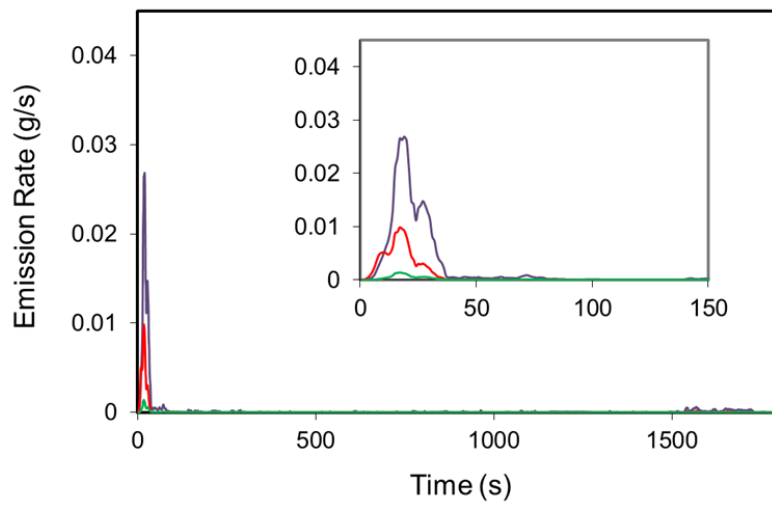
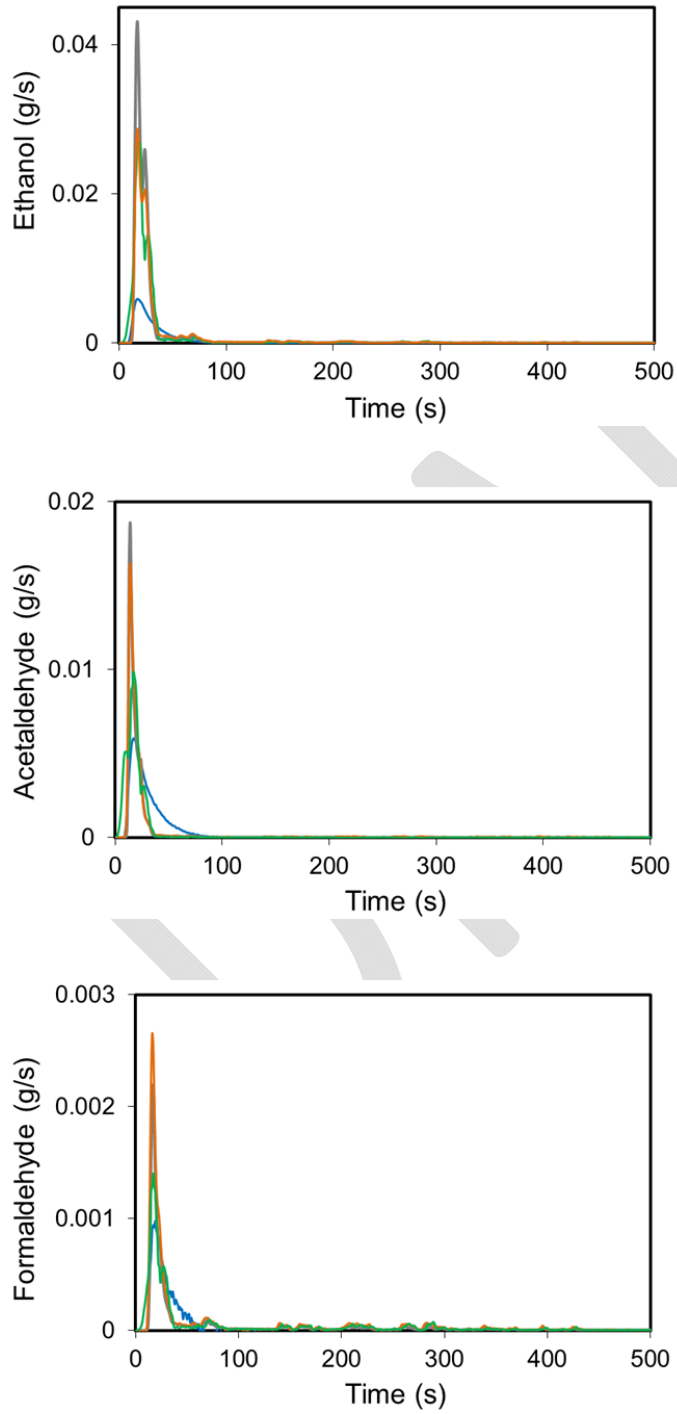

Figure 11. Online emission profiles of EtOH, CH₃CHO and HCHO measured using FTIR-1 (orange), FTIR-2 (blue), PTR-Qi-ToF-MS (grey) and FTIR-3 (green) over the WLTC. The figures show only the first 500 seconds of the cycle.



4. Conclusions

The validation phase of the Additional Pollutants of the world-harmonized light-duty vehicle test procedure (WLTP) aiming at measuring ethanol, formaldehyde and acetaldehyde (EtOH, HCHO and CH₃CHO, respectively) emissions from a Flex-Fuel vehicle using E85 at the dilution tunnel over the WLTC, was successfully conducted in the Vehicle Emission Laboratory (VELA) at the European Commission Joint Research Centre (EC-JRC), Ispra, Italy.

During the exercise there were found *in situ* and also online analytical instrumentation capable of measuring the three additional pollutants (EtOH, HCHO and CH₃CHO) from the diluted exhaust (sampled at the CVS) with good repeatability and reproducibility. All tested instruments resulted to be in good agreement. Hence, the intercomparison of all analytical instrumentation measuring at the CVS was very satisfactory.

Acknowledgments

The VELA staff is acknowledged for the skilful technical assistance, in particular M. Cadario, R. Colombo, B. Giechaskiel, G. Lanappe, P. Le Lijour, and M. Sculati.

References

1. Uherek, E., et al., *Transport impacts on atmosphere and climate: Land transport*. Atmospheric Environment, 2010. **44**(37): p. 4772-4816.
2. European Commission, *Directive 2009/30/EC of the European parliament and of the council of 23 April 2009 amending directive 98/70/EC as regards the specification of petrol, diesel and gas-oil and introducing a mechanism to monitor and reduce greenhouse gas emissions and amending council directive 1999/32/EC as regards the specification of fuel used by inland waterway vessels and repealing directive 93/12/EEC*. Official Journal of the European Communities, 2009. **L140/88**.
3. The European Parliament and The Council of the European Union, *Directive 2009/28/EC of The European Parliament and The Council of the European Union of 23 April 2009 on the promotion of the use of energy from renewable sources and amending and subsequently repealing Directives 2001/77/EC and 2003/30/EC*. Official Journal of the European Union, 2009. **L 140**.
4. European Commission, *Renewable energy progress and biofuels sustainability. Report from the Commission to the European Parliament, The Council, The European Economic and Social Committee and the Committee of the Regions*. 2013. **COM(2013) 175**.
5. Unger, N., et al., *Attribution of climate forcing to economic sectors*. Proceedings of the National Academy of Sciences, 2010. **107**(8): p. 3382-3387.

6. Balat, M., H. Balat, and C. Öz, *Progress in bioethanol processing*. Progress in Energy and Combustion Science, 2008. **34**(5): p. 551-573.
7. Environmental Protection Agency. <http://www.epa.gov/otaq/regs/fuels/additive/e15/index.htm>.
8. Clairotte, M., et al., *Effects of low temperature on the cold start gaseous emissions from light duty vehicles fuelled by ethanol-blended gasoline*. Applied Energy, 2013. **102**(0): p. 44-54.
9. Durbin, T.D., et al., *Effects of Fuel Ethanol Content and Volatility on Regulated and Unregulated Exhaust Emissions for the Latest Technology Gasoline Vehicles*. Environmental Science & Technology, 2007. **41**(11): p. 4059-4064.
10. Graham, L.A., S.L. Belisle, and C.-L. Baas, *Emissions from light duty gasoline vehicles operating on low blend ethanol gasoline and E85*. Atmospheric Environment, 2008. **42**(19): p. 4498-4516.
11. Suarez-Bertoa, R., et al., *Impact of ethanol containing gasoline blends on emissions from a flex-fuel vehicle tested over the Worldwide Harmonized Light duty Test Cycle (WLTC)*. Fuel, 2015. **143**: p. 173-182.
12. Forster P., R.V., Artaxo P., Berntsen T., Betts R., Fahey D.W., Haywood J., Lean J., Lowe D.C., Myhre G., Nganga J., Prinn R., Raga G., Schulz M., and Van Dorland R, *Changes in Atmospheric Constituents and in Radiative Forcing*. In: *Climate Change 2007: The Physical Science Basis. Climate Change 2007: The Physical Science Basis*, 2007: Cambridge, United Kingdom and New York, NY, USA. p. 129-234.
13. Hallquist, M., et al., *The formation, properties and impact of secondary organic aerosol: current and emerging issues*. Atmos. Chem. Phys., 2009. **9**(14): p. 5155-5236.
14. Pope, I.C., et al., *Lung cancer, cardiopulmonary mortality, and long-term exposure to fine particulate air pollution*. JAMA, 2002. **287**(9): p. 1132-1141.
15. Brasseur G., O.J., and Tyndall G., *Atmospheric Chemistry and Global Change* 1999: Oxford University Press.
16. Corrêa, S.M., et al., *Five years of formaldehyde and acetaldehyde monitoring in the Rio de Janeiro downtown area – Brazil*. Atmospheric Environment, 2010. **44**(19): p. 2302-2308.
17. Saleh, R., et al., *Brownness of organics in aerosols from biomass burning linked to their black carbon content*. Nature Geosci, 2014. **7**(9): p. 647-650.
18. European Commission, *Regulation (EC) No 443/2009 of the European Parliament and Parliament of the Council of 23 April 2009 setting emission performance standards for new passenger cars as part of the Community's integrated approach to reduce CO2 emissions from light-duty vehicles* Official Journal of the European Communities, 2009. **L140/1**.
19. International Organization for Standardization. *ISO 17043:2010 - Conformity assessment - General requirements for proficiency testing*, 2010, ISO: Geneva.
20. International Organization for Standardization. *ISO 5725-2:1994 - Accuracy (trueness and precision) of measurement methods and results -- Part 2: Basic method for the determination of repeatability and reproducibility of a standard measurement method*, 1994, ISO: Geneva.