

GLOBAL REGISTRY

Created on 18 November 2004, pursuant to Article 6 of the
AGREEMENT CONCERNING THE ESTABLISHING OF GLOBAL TECHNICAL
REGULATIONS FOR WHEELED VEHICLES, EQUIPMENT AND PARTS WHICH CAN BE
FITTED AND/OR BE USED ON WHEELED VEHICLES
(ECE/TRANS/132 and Corr.1)
Done at Geneva on 25 June 1998

Addendum

Global technical regulation No. 6

SAFETY GLAZING MATERIALS FOR MOTOR VEHICLES
AND MOTOR VEHICLE EQUIPEMENT

(Established in the Global Registry on 12 March 2008)



UNITED NATIONS

CONTENTS

	<u>Page</u>
A. STATEMENT OF TECHNICAL RATIONALE AND JUSTIFICATION.....	5
1. INTRODUCTION	5
(a) History of the global technical regulation.....	5
(b) Summary	5
(c) Background	6
2. TECHNICAL RATIONALE AND JUSTIFICATION	7
(a) Existing Requirements/Tests not Included in the gtr.....	7
(b) Common Requirements in All of the Regulations	7
(c) Mechanical Properties.....	7
(d) Optical Properties	11
(e) Atmospheric Resistance.....	12
(f) Application	12
(g) Markings	13
(h) Sampling	13
(i) Summary Chart	14
B. TEXT OF REGULATION	
1. PURPOSE	18
2. APPLICATION/SCOPE.....	18
3. DEFINITIONS	18
4. GENERAL REQUIREMENTS.....	21
4.1 Markings.....	21
4.2. Particular provisions	22
5. PERFORMANCE REQUIREMENTS	23
5.1. Requirements Applicable to All Glazing	23
5.1.1. Light Transmittance Test	23
5.1.2. Test of Resistance to Abrasion	24
5.2. Requirements Applicable to All Glazing Faced with Plastic.....	24
5.2.1. Test of Resistance to Temperature Changes	24
5.2.2. Test of Resistance to Fire	24
5.2.3. Test of Resistance to Chemicals.....	24
5.3. Requirements Applicable to All Laminated Glass and All Glazing Faced with Plastic	25
5.3.1. Test of Resistance to Radiation	25
5.3.2. Test of Resistance to High Temperature	25
5.3.3. Test of Resistance to Humidity	25
5.4. Requirements Applicable to Windscreens	25
5.4.1. Optical Distortion Test.....	26
5.4.2. Secondary Image Separation Test	27
5.4.3. Head-form Test on Windscreens	27
5.4.4. 2,260 g Ball Test.....	28
5.4.5. 227 g Ball Test.....	28

CONTENTS (continued)

	<u>Page</u>
5.5. Requirements Applicable to Panes.....	29
5.5.1. Requirements Applicable Only to Uniformly-Toughened Panes	29
5.5.1.1. Fragmentation Test.....	29
5.5.1.2. 227 g Ball Test	29
5.5.2. Requirements Applicable Only to Laminated-Glass and Glass-Plastic Panes	29
5.5.2.1. 227 g Ball Test	30
5.5.3. Requirements Applicable Only to Double-Glazed Units	30
5.5.3.1. Individual Components.....	30
5.5.3.2. Head-form Test	30
6. TEST CONDITIONS AND PROCEDURES	31
6.1. Test Conditions	31
6.2. Fragmentation Test.....	31
6.3. 227 g Ball Test	32
6.4. 2,260 g Ball Test	35
6.5. Head-form Tests.....	36
6.6. Test of Resistance to Abrasion.....	39
6.7. Test of Resistance to High Temperature	43
6.8. Test of Resistance to Radiation.....	44
6.9. Test of Resistance to Humidity	45
6.10. Test of Resistance to Temperature Changes	45
6.11. Light Transmittance Test.....	46
6.12. Optical Distortion Test	47
6.13. Secondary Image Separation Test.....	51
6.14. Test of Resistance to Fire.....	54
6.15. Test of Resistance to Chemicals.....	61
7. ANNEXES	62
7.1. Procedures for Determining Test Areas on Windscreens	62
7.2. Measurement of the Height of Segment and Position of the Points of Impact	71

A. STATEMENT OF TECHNICAL RATIONALE AND JUSTIFICATION

1. INTRODUCTION

(a) History of the global technical regulation (gtr)

1. At the one-hundred-and-thirty-second session of the World Forum for Harmonization of Vehicle Regulations (WP.29) in March 2004, the formal proposal to develop a gtr on safety glazing was adopted (TRANS/WP.29/AC.3/9), with a restriction of its scope to glass safety glazing (excluding other materials such as plastics).

2. While some Contracting Parties allow the use of plastic glazing for window panes in vehicles, other Contracting Parties prohibit plastic glazing due to its limited durability. Historically, plastic glazing degrades gradually over time, particularly due to the effects of weather, radiation, oxidation and mechanical abuse. In such cases, the visibility of the glazing is greatly reduced. Therefore, to avoid contentious, time-consuming discussions and to expedite the development of the gtr at the one-hundred-and-thirty-third session of WP.29, the Executive Committee of the 1958 Agreement (AC.3) agreed to exclude plastic glazing from the gtr.

3. An informal group (IG) was established under the Chairmanship of Germany, the sponsor of the gtr. The IG developed and submitted a draft gtr to the Working Party on General Safety Provisions (GRSG) for its ninetieth session. The first report was submitted to WP.29 for its one-hundred-and-thirty-sixth session, in June 2005. Based on comments from Canada and the United States of America, the draft was returned to the informal group for further consideration.

4. Two issues were raised in the informal group, the installation and the markings. Existing national or regional regulations/legislation include prescriptions on which kind of glazing may or may not be installed at certain locations and/or in certain vehicles. In particular, the requirements for light transmission levels in glazing installed in rearward vision areas vary widely. Existing national or regional regulations also specify marking requirements that indicate the type of material and/or the regulations/legislation it meets. The informal group was not clear as to whether a global marking to demonstrate compliance with the gtr requirements would be proper within the scope of a gtr. Responding to questions from the IG, at the one-hundred-and-thirty-seventh session of WP.29, in November 2005, AC.3 agreed that the gtr would not include installation requirements and that the group could consider the possibilities to include markings in the gtr (TRANS/WP.29/1047, para. 96). However, at the one-hundred-and-fortieth session of WP.29, in November 2006, the European Commission submitted a proposal concerning markings for gtr's in general. As this proposal would be discussed at later sessions of WP.29 only markings concerning the type of material are included in this gtr.

(b) Summary

5. The draft gtr specifies performance requirements for various types of glazing (i.e., laminated and toughened glass) intended for installation in Category 1 and 2 vehicles as defined in Special Resolution No. 1. The requirements apply to glazing as an item of equipment, and do not include installation requirements for vehicles. Performance requirements for some of the materials are different if the material is intended for installation as a windscreen or as a pane.

The draft gtr includes requirements and tests to ensure that the mechanical properties, optical qualities and environmental resistance of glazing are satisfactory.

6. Four tests and requirements are used in the gtr for mechanical properties: a fragmentation test, a 227 g steel ball, a 2.26 kg steel ball and a 10 kg head-form. The first three appear in all of the national or regional regulations. The fragmentation test in this gtr is similar to those included in UNECE Regulation No. 43 "Uniform Provisions Concerning the Approval of Safety Glazing and Glazing Materials." The 227 g steel ball and 2.26 kg steel ball tests are similar in the national or regional regulations examined and the differences were resolved in the gtr. The major difference from all existing regulations is the drop height for the small ball test for uniformly toughened glass panes. Based upon analysis conducted by Japan, which demonstrated that the force from a drop height of 2.0 m represented the force of a typical object impacting a pane, it was decided that a drop height of 2.0 m could be retained. The head-form test in this gtr specifies one drop height, and not two as in European and Asian regulations.

7. Three types of optical qualities are addressed by the gtr: light transmission, optical distortion and double image. The minimum light transmittance level for glazing required for the driver's forward field of vision is 70 per cent as it is in North American and Asian regulations, and not 75 per cent as it is in European regulations. This is justified by costs/benefits analysis. The test procedure is based on the UNECE test procedure. The main difference from the other tests in the national or regional regulations examined was not the requirements, but the test procedure. This was resolved by selecting the test procedure that was most similar to real-world conditions.

8. For environmental resistance, the gtr includes requirements related to temperature change, fire, chemical resistance, abrasion, radiation, high temperature and humidity. The first four of these were common to all the examined regulations. Minor differences in the other three were resolved for the gtr.

9. The IG understands that research to update some of the environmental tests is currently being conducted within the glazing industry. However, for the time being, the gtr can only consider the available practice and test requirements. Once the new test procedures/test equipments are validated and updated by the industry, proposals could be made to update the gtr accordingly. Other areas that could be the subject of future proposals to upgrade the gtr such as installation provisions, plastic glazing, and unified markings, are subject to the approval by WP.29 and AC.3.

(c) Background

10. Standards covering the performance requirements for vehicle glazing have been in existence in Europe and in the United States of America since the late 1930s. Early standards include the American National Standard for Safety Glazing Materials for Motor Vehicles and Motor Vehicle Equipment Operating on Land Highways – Safety Standard ANSI Z26 and the British Standard 857 "Safety Glass for Land Transport." These early voluntary standards form the basis for later mandatory national standards.

11. Due to the absence of candidate regulations in the Compendium, a number of national or regional regulations were examined in developing this gtr, including those of Canada, China, the UNECE, Japan and the United States of America. Voluntary standards were also examined, including those of American National Standard Institute (ANSI) and the International Standardization Organization (ISO).

12. The attached summary chart compares the existing regulations in Europe, the United States of America and Japan for the most commonly used types of glazing materials. In many cases the technical requirements are the same or similar. However, there are some differences in the requirements for mechanical properties and optical qualities.

2. TECHNICAL RATIONALE AND JUSTIFICATION

13. Vehicle glazing contributes to vehicle safety in numerous ways. For this reason, it shall satisfy a set of performance requirements. The following general properties are desired:

- (i) Vehicle glazing shall have good mechanical strength and fracture resistance. **Mechanical strength will help to ensure that objects, such as road debris thrown against the glazing do not penetrate into the occupant compartment.** Mechanical strength can also help prevent occupant ejection in the event of a crash. Good fracture characteristics minimize the likelihood of injury in the case of breakage;
 - (ii) Vehicle glazing shall also have good optical properties. This will ensure that the glazing is sufficiently transparent to provide a good view of the road and does not cause any distortions in the vision;
 - (iii) **To ensure continued performance throughout the life of the vehicle, the glazing should be resistant to conditions encountered in normal usage.** This includes atmospheric humidity, temperature fluctuations and abrasion. For glazing with exposed plastic surfaces, this would also include chemicals and combustion.
- (a) Existing requirements/tests not included in the gtr

Kommentar [m1]: Proposed change =
Only additional explanation for
clarification: no change of content

Kommentar [m2]: Proposed Change =
Only additional explanation for
clarification: no change of content

14. The European and Asian regulations include a requirement for colour recognition. The requirement was originally adopted to prevent confusion concerning traffic signals. The North American regulations do not include such a requirement, nor was it adopted by ISO. Experience has shown that colour distortion is not a problem at the light transmission levels allowed by any national or regional regulation for windscreens. For lack of safety justification, the requirement is not included in the gtr.

15. The North American regulations include a 4.99 kg shot bag test. The test requires a leather bag filled with lead shot. Experience has shown that it is difficult to obtain consistent results because variations in the suppleness of the leather play a significant role in the distribution of force on the impact area. For lack of objectivity, the test was not included in the gtr.

16. The North American regulations also include a 198 g dart test. The dart test is a test that causes fracture and delaminated areas for laminated windscreens and panes. The 227 g ball test

evaluates the same characteristics. Because the dart is very close in mass to the 227 g ball, the tests provide similar information. For this reason the 227 g ball test is included in the gtr only because the slightly increased weight makes the test slightly more severe.

17. The European and Japanese regulations include head-form tests at both 1.5 m and 4 m drop heights. The test at the 4 m drop height is not included in this gtr. The 4 m drop height test shall be conducted on specially manufactured test pieces rather than normal production parts. The primary benefit of this test is to assess the penetration resistance, which is already assessed in other test protocols included in the gtr.

(b) Common requirements in all of the regulations

18. All of the regulations considered include identical requirements for glazing with an exposed plastic layer. These requirements are tested for the resistance to:

- (i) Temperature change;
- (ii) Fire;
- (iii) Chemicals (e.g., cleaning compounds);
- (iv) Abrasion.

19. By its nature, glass glazing is resistant to these factors. However glazing with an exposed plastic face could have low resistance. If the glazing were not resistant to temperature changes, chemicals or abrasion, the ability of a driver to see through the glazing would be compromised. If the glazing permitted a fire to spread on an exposed plastic surface, this could also be a hazard to the occupants of the vehicle. Because a safety of justification for these requirements exists, they were included in the gtr.

(c) Mechanical properties

20. There are basically two types of glass-based glazing used in automotive applications, the toughened (also known as tempered) and the laminated. There are differences between them in the manufacturing process, weight, cost, strength and fracture properties.

21. Toughened glass is produced using a manufacturing method (heat tempering) that introduces internal stresses in glass. Heat tempering increases the mechanical strength of the glass, so it resists to breakage. In the event that the glass does break, it shatters into numerous small, blunt-edged pieces rather than large and/or sharp fragments, reducing the risk of injury to an occupant struck by the broken glazing.

22. Laminated glazing consists of two glass panes sandwiching a plastic interlayer, which is inserted after the glass panes have been bent to the desired shape. The total assembly is highly resistant to penetration, and in the case of breakage, many small, fragments are held in place by the interlayer. This reduces the risk of head injury. In the case of an impact with a foreign object, emergency visibility is maintained. For these reasons this gtr only specifies requirements for laminated glazing windcreens, using laminated glass or glass-plastics.

23. For mechanical properties four types of tests are include into the gtr:

- (i) fragmentation test;
- (ii) 227 g steel ball test;
- (iii) 2.26 kg steel ball test; and
- (iv) 10 kg head-form test.

24. The purpose of the fragmentation test is to determine whether the glazing is causing injury when it does breaks. In the case of breakage, it is desired that the glazing shatter into very small, blunt pieces rather than large, sharp fragments thereby significantly reducing the risk of serious injuries. The fragmentation test is applicable only to toughened and not laminated panes because in the later case the majority of fragments will be held in place by the interlayer. The ability of the interlayer to hold these fragments in place is evaluated in the 227 g ball test.

25. There are two significant differences between the North American regulations and the European and Asian regulations. The North American regulations specify only one breaking point, while the others specify four breaking points. The North American regulations specify that the largest fragment cannot exceed a specific weight, while the European and Asian regulations require a minimum and maximum number of fragments and specify additional limits on the maximum length and area of any single fragment.

26. When a toughened pane is broken, the fracture pattern observed depends not only on the degree of thermal toughening introduced in the processing, but also on the peripheral shape of the pane and the location of the point of fracture. There is a complex interaction between the developing crack and the resultant stress wave that is reflected back from the edges of the pane. As a general rule the centre break position is the most critical. However, if a pane has a significant degree of curvature at the lateral extremities, a geometric centre break point can mask toughening issues. Adding an additional fragmentation point in the region of smallest radius, it can be verified if the glass has been properly toughened.

27. After reviewing all of these regulations the experts agreed that two breaking points could be specified and adopted the minimum number of fragments count technique with additional limits on fragment size and shape. The centre breaking position is specified for all panes. For panes with complex curves, an additional test point is introduced at the place where the minimum radius of curvature "r", on the longest median, is less than 200 mm. Specifying this point means that the additional test points in the European and Asian regulations are not required. The value of 200 mm is based on tests carried out by the European test laboratories e.g. Material Prüfungs-Amt (MPA), British Standard Institute (BSI) and L'Union Technique de l'Automobile, du Motorcycle et du Cycle (UTAC).

28. Both the North American technique of weighing the largest fragment and the European/Asian technique of counting fragments are intended to ensure that, the glazing breaks into a large number of small fragments to reduce the severity of lacerations risks.

29. While the North American technique is a simpler test to perform, the recent use of very thin toughened glazing would permit a significant increase of the fragment size. For this reason assessing the number of fragments and limiting their area seemed to provide the greatest measure of safety.

30. The purpose of the 227 g steel ball test is to assess the resistance of the glazing to impacts from stones or other flying objects that might be encountered in everyday use. For uniformly toughened glass panes, in Europe and Asia, a drop height of 2.0 to 2.5 m, depending on the thickness of the glazing, is specified. In the United States of America, a drop height of 3.05 m is specified. Tests in Japan led to the conclusion that a drop height of 2.0 m is sufficient for this type of glazing. The typically encountered stone was determined to have a mass of 2-3 g. In the case of a windscreen, an impact velocity of 150 km/h may be reached. However, the impact velocity on a windscreen is largely determined by the speed of the vehicle, which is not the case for panes where the impact velocity will be lower. Assuming a worst-case impact velocity of 150 km/h, the impact energy of a 3 g object would be equivalent to the impact energy of the 227 g ball dropped from a height of 1.17 m. Therefore, it was decided that the lowest height, 2 m, used in any national or regional regulation, would be sufficient to assess a pane impacted by a stone or other small object. This lower drop height will also allow the use of thinner panes, resulting in a weight reduction that could contribute to lower fuel consumption.

31. For other glazing the differences between the regulations examined generally related to the drop height used during the test. The gtr specifies a drop height of 9 m as in the North American regulations for windscreens. Unlike panes, the impact force on windscreens is difficult to determine as it depends on the velocity of both the object and the vehicle. Quite frequently existing glazing is manufactured to meet the most severe test conditions in existing regulations around the globe, and therefore the feasibility of meeting the more severe standard is demonstrated. Therefore, the North American test height was chosen to ensure that the glazing is resistant to penetration under ambient conditions. The drop heights in the European and Asian regulations were kept for the low and high temperature tests, to assess the interlayer performance over extreme temperature conditions.

32. The purpose of the 2.26 kg steel ball test is to assess the penetration resistance of laminated glazing materials used for windscreens to impact from a heavy object. The U.S.A. regulation requires a resistance to penetration from 3.66 m while the European and Japanese regulations require performance from 4.0 m. Many windscreens produced in the U.S.A. are dual certified for both the 3.66 m and the 4.0 m performance levels already. Therefore the higher height of 4.0 m was selected for inclusion in the gtr.

33. The assessment of the ability of a laminated windscreen to absorb impact energy is a significant feature in relation to the safety of vehicle occupants. The purpose of both the large ball test currently specified in the Federal Motor Vehicle Safety Standard (FMVSS), the UNECE and the Japanese safety regulation and the "head-form" test currently specified in the Japanese and the UNECE regulations is to ensure that the vehicle windscreen remains sufficiently intact to reduce the chance of occupant ejection, without being so stiff as to cause serious injury during a frontal crash. Both of these tests continue to serve an important purpose in regulations by supplementing the protection afforded by newer requirements such as the introduction of airbags, the requirements for a frontal crash test and increased seat belt use. However, given that these tests have been mandated for decades and in many cases before the additional tests for frontal crash protection were mandated, it is difficult to quantify and correlate the benefits of these tests to real world performance. For example, contracting parties that have not mandated the head-form test could not justify imposing regulatory costs in light of the unquantified benefits. On the

Kommentar [m3]: Proposed Change = Only additional explanation for clarification: no change of content

other hand, contracting parties that have mandated the head-form test could not justify deleting it, since they could be losing benefits even if those benefits are difficult to quantify. Accordingly, GRSG agreed to recommend that each contracting party to the 1998 Agreement may decide whether to apply the head-form test in its national/regional law.

(d) Optical properties

34. The relationship between light transmission and a driver's visual needs is complex. Factors involved include visual acuity, prevailing contrast levels, vehicle speed and the location of the glazing in the vehicle. Body tinted heat absorbing and heat reflecting darker glazing is desired to reduce the amount of heat from solar radiation entering the vehicle, however, darker glazing also reduces the ability to see out of the vehicle. In developing the gtr, there was agreement that glazing requisite for the driver's primary visibility should exhibit good light transmission properties. All existing national or regional regulations require higher levels of light transmission for glazing at locations that the driver would use for his forward field of view, e.g., windscreens and some side panes. In many instances where existing national or regional regulations allow lower levels of light transmission at locations to the rear of the driver, this allowance is tied to a requirement for rear-view mirrors.

The divergence in national legislation regarding light transmission levels for rearward field of view glazing is one of the main issues that led the informal group to request advice from AC.3 on including provisions in the gtr when various types of glazing could be installed in a vehicle. However, since AC.3 determined that the gtr should not include installation provisions, making lower light transmittance levels provisional on other items of equipment could not be included in this gtr. Therefore, the use of darker glazing to the rear of the driver is at the discretion of the Contracting Parties.

35. With regard to the light transmittance requirements for forward vision, the gtr specifies a minimum level of 70 per cent light transmittance. Current national or regional regulations specify either 70 per cent (North America) or 75 per cent (UNECE). Laboratory test studies ^{1/} and vehicle accident data do not show any influence on safety with the lower minimum limit for light transmission. Therefore this level was selected for the gtr.

36. The gtr specifies limits on distortion and double image. If the glazing caused too much distortion or created double images this could lead to driver confusion. The main differences among the existing national or regional regulations are not in the levels specified but in the test methods for both of these requirements. In the North American and Canadian regulations, the test method specifies measuring at normal incidence (perpendicular) to the glazing surface. By contrast, the European and Asian regulations specify measuring in defined vision areas at the intended installation angle of the glazing. Because the European and Asian regulations evaluate the image seen by the driver, these tests were included in the gtr.

37. At the time many of the early regulations were developed, the angle of installation of most windscreens was very low, that is close to vertical. Modern windscreens can be complex in terms of styling. They are larger, with high angles of inclination (typically in excess of 60 ° to

^{1/} Report PPAD 9/33/39 "Quality and Field of Vision – A Review of the Needs of Drivers and Riders," Institute of Consumer Ergonomics – Loughborough. February 2003.

the vertical) and shaped to bend into the bodywork to improve aerodynamics. Distortion is a function of the angle of incidence and can be up to 10 times greater at an inclination of 62 ° than at normal incidence. For this reason, the gtr specifies testing at the intended installation angle to ensure that the distortion measured accurately reflects what a driver might encounter.

38. The gtr specifies optical testing in the vision areas currently specified in the European and Asian regulations. Because modern windscreens are larger, the actual area used by the driver under normal conditions is limited. Because of the shaping of the windscreen at the margins, often curving in more than one direction, there are practicality concerns with testing the entire windscreen. The areas specified in the European and Asian regulations are based on Society of Automotive Engineers (SAE) Recommended Practice J941 "Motor Vehicles Drivers Eye Locations." The Recommended Practice is based on a study involving over 2300 drivers, with a male-to-female ratio of one-to-one, performing a straight ahead driving task (SAE Paper 650464). Elliptical contours defining a range of eye positions were developed from a statistical analysis of the physiological data. These contours, or eye ellipses, offer a representation of a driver's eye location and can be used to determine what a driver could see. Balancing the practicality concerns with the fact that the eye ellipses offer a good estimate of the windshield area that could typically be used by the driver, testing only in these areas is specified.

(e) Atmospheric resistance

39. The tests in this category are intended to ensure that the glazing will withstand exposure to atmospheric conditions that might be encountered in normal use. These tests only apply to laminated glazing and glazing with an exposed plastic face. Glass is by its nature a stable and durable product and would not be affected by the atmospheric conditions. Plastic can be less durable and stable, as are the materials used to bond the layers. In addition, if improperly constructed, air or moisture could penetrate between the layers. The following tests ensure that durable plastic and good construction are materials used in these products.

40. The first of these tests, resistance to radiation, involves exposure to a UV light source. The major difference between the American and UNECE Regulations is that the American regulation specifies 100 hours exposure, using a specified radiation source, while the UNECE Regulation specifies 100 hours of exposure at 1400 W/m². Since the UNECE Regulation ensures a constant level of exposure and allows for alternative sources of UV radiation during testing, it is used in the gtr.

41. The remaining atmospheric tests, resistance to high temperatures and resistance to humidity, determines whether the glazing can withstand prolonged exposure to high temperatures and humidity it could be exposed to during its expected life. The differences between the existing regulations are minor differences in the maximum distance from an edge within which a defect is allowed to appear during the test. The distances specified in the European and Asian regulations were chosen for the gtr as they were even multiples of 5 and because they include a second, slightly larger, limit for edges that had to be cut to conduct the test. Cutting glazing introduces stress and it is reasonable to allow defects for a slightly larger difference when such an edge would not exist in a production piece.

(f) Application

42. The gtr is applicable to glazing intended for installation in Category 1 and 2 vehicles as defined by Special Resolution No. 1. These definitions cover vehicles glazing included within the scope of both the existing regulations and the 1998 Agreement. As explained above, based on guidance from WP.29, the gtr specifies requirements for glazing as an item of motor vehicle equipment and not for the vehicle.

(g) Markings

43. Existing national or regional regulations require markings on glazing that generally fall into three categories:

- (i) The type of material the glazing is constructed from;
- (ii) The manufacturer of the glazing; and
- (iii) The regulation(s) the glazing is manufactured to comply with.

44. In the first category, the regulations vary only in the symbol used for each material, not the content. In the second category, some regulations require a trade name or mark, some require an assigned identifier, and others require a higher level of detail, for example, not just the manufacturer but the actual plant where the glazing was fabricated. The third category generally reflects differences in enforcement mechanisms in various countries.

45. This gtr specifies marking requirements for only the first category. The marking system in UNECE Regulation No. 43 was the starting point. However, some additional markings were added to make sure each type of glazing which has unique requirements under the gtr has a unique marking.

46. Contracting Parties will be able to continue to require additional markings in one or both of the other two categories. While some manufacturers would also like the gtr to include markings in these categories, thus eliminating the need to add multiple markings if the glazing is sold in more than one country, they are not included at this time.

(h) Sampling

47. Whenever possible it is desirable to test actual production parts and/or test pieces cut from production parts. However, in the abrasion and 1.5 m head-form test for double-glazed panes, the test piece shall fit a holder or support frame. Since it is not practicable to design a new holder or support frame for each production part, these tests specify the testing of specially prepared test pieces. It is expected that the test pieces would be identical to the glazing in production parts, except for the shape and/or size.

(i) Summary chartLaminated windscreens

TEST	EUROPE UNECE Regulation No.43	JAPAN Safety Regulations for Road Vehicles, Article 29	USA FMVSS 205	DRAFT GLOBAL TECHNICAL REGULATION
Windscreen optics	Tests on windscreens <ul style="list-style-type: none"> • using defined vision areas • at the installation angle • Test method ISO 3538 	Tests on windscreens <ul style="list-style-type: none"> • using defined vision areas • at the installation angle • Test method ISO 3538 	Test of 12" squares which may be cut from the most curved part of the windscreen <ul style="list-style-type: none"> • no defined vision area • not tested at the installation angle • not as ISO 3538 	As UNECE Regulation No. 43
Light transmission	TL \geq 75 per cent Test method ISO 3538	TL \geq 70 per cent Test method ISO 3538	TL \geq 70 per cent Test method ISO 3538	TL \geq 70 per cent i.e. as for USA, Japan and Directive 77/649/EEC Forward Field of Vision
Light stability High temperature Humidity Fire resistance	Test method as ISO 3917 Burning rate <250 mm/min	Test method as ISO 3917 Burning rate < 89 mm/min	Test method as ISO 3917 but The evaluation for high temperature and humidity tests not as Europe and Japan Burning rate < 88.8 mm/min	Test method as ISO 3917 Evaluation as Europe and Japan Burning rate < 90 mm/min
Impact 227g Ball	Test method ISO 3537 Tests at + 40°C and - 20°C Varying drop heights according to thickness	Test method ISO 3537 Test at + 40°C and - 20°C Varying drop heights according to thickness	Test method ISO 3537 Test at 25°C Standard drop height	Test method ISO 3537 Test at + 40°C and - 20°C One standard drop height at each temperature

Laminated windscreens (continued)

TEST	UNECE Regulation No. 43	JAPAN Safety Regulations for Road Vehicles, Article 29	USA FMVSS205	DRAFT GLOBAL TECHNICAL REGULATION
Impact 198g Dart	No test	No test	Test at 25° C. No ISO test.	No test
Penetration Resistance 2.26 kg ball	Test method: ISO 3537 Drop height 4.0 m	Test method: ISO 3537 Drop height 4.0 m	Test method: ISO 3537 Drop height 3.66 m	As UNECE Regulation No. 43
Abrasion Resistance	Test method: ISO 3537	As UNECE Regulation No. 43	As UNECE Regulation No. 43	As UNECE Regulation No. 43
Headform Impact Test	Test method: ISO 3537 Evaluation of penetration resistance and breaking pattern 4 m drop test on flat test pieces. 1.5 m drop test on windscreens	Test method: ISO 3537 Evaluation as UNECE Regulation No. 43 Testing as UNECE Regulation No. 43	No test	The headform 1.5 m drop test on windscreens is included. (The ECE R43 and Japanese test at 4.0 m on flat test pieces is not included)
Colour Identification	Test to verify that traffic light colors can be recognized. Not an ISO test	As UNECE Regulation No. 43	No test	No Test

Toughened bodyglass

Test	UNECE Regulation No. 43	JAPAN Safety Regulations for Road Vehicles, Article 29	USA FMVSS 205	DRAFT GLOBAL TECHNICAL REGULATION
Impact test 227 g Ball	<ul style="list-style-type: none"> • Test method: ISO 3537 • Drop heights: thickness ≤ 3.5 mm – 2.0 m thickness > 3.5 mm - 2.5 m • Flat 300 x 300 mm test pieces or finished products 	<ul style="list-style-type: none"> • ISO 3537 • Drop heights as ECE R43 • Flat 300 x 300 mm test pieces 	<ul style="list-style-type: none"> • Test method: ISO 3537 • Drop height: 3.05m • Flat 305 x 305 mm test pieces 	<p>As UNECE Regulation No. 43</p> <p>Standard drop height: 2.0 m</p>
Impact test 4.99 kg shot bag	No test	No test	No ISO test. Drop height: 2.40 m	No test
Abrasion test	No test for the glass surface If plastic coated, then: test method: ISO 3537	As ECE R43	<ul style="list-style-type: none"> • Test method: ISO 3537 • Carried out on bodyglass requisite for driving visibility 	As UNECE Regulation No. 43
Light transmission	<ul style="list-style-type: none"> • Test method: ISO 3538 • In areas requisite for driving visibility: • $T_L \geq 70$ per cent In areas not requisite for driving visibility: T_L no lower limit	As UNECE Regulation No. 43	<ul style="list-style-type: none"> • Test method: ISO 3538 • For passenger cars the TL limit is ≥ 70 per cent , except for rooflights For other vehicles the limits are as UNECE Regulation No. 43 <ul style="list-style-type: none"> • and Japan. 	As UNECE Regulation No. 43
Optical quality	No test	Sidelights requisite for driving visibility	No test	As UNECE Regulation No. 43

ECE/TRANS/180/Add.6
page 16

Kommentar [m4]: Additional change according to
discussion in IWG PSG

Toughened bodyglass (continued)

Test	ECE Regulation No. 43	JAPAN Safety Regulations for Road Vehicles, Article 29	USA FMVSS 205	DRAFT GLOBAL TECHNICAL REGULATION
Fragmentation	<p>Test procedure ISO 3537</p> <ul style="list-style-type: none"> • Production parts are broken using a spring loaded centre punch or pointed hammer from 4 defined breaking points • The minimum particle count allowed is 40 (in any 5x5 cm sided square) with an upper limit of 450 for a thickness < 3.50 mm. 400 for thickness >3.5 mm • No elongated particles (splines) in excess of 7.5 cm are permitted • The maximum particle size allowed is 3 cm² <p>NB: Some deviations on the above are permitted. Example: splines up to 10 cm</p>	<p>ISO 3537</p> <p>Requirements are similar to those specified in UNECE Regulation No. 43</p> <p>Some small differences in the allowed deviations</p> <p>Deviation examples:</p> <ul style="list-style-type: none"> • splines up to 15 cm • in case particle count < 40, then: particle count >= 160 in any 10 x 10 cm square is acceptable 	<p>Fragmentation test as ISO 3537, with only one defined break position (25 mm inboard of the mid-point of the longest edge)</p> <p>The interpretation of results is based on the weight of the largest fragment, which shall not exceed 4.25 g. This equates to the following maximum particle sizes: 3 mm thickness: 5.6 cm² 4 mm thickness: 4.2 cm² 5 mm thickness: 3.4 cm²</p> <p>No evaluation of the length of fragments.</p>	<p>As UNECE Regulation No. 43, with some changes:</p> <ul style="list-style-type: none"> • a single centre break position is specified. • the upper particle count limit is removed. Minimum limit remains at 40. • the elongated particle limit is raised from 7.5 to 10 cm • Determination of the largest particle weight rather than of the area, e.g. for glass up to 4.5 mm thickness the weight shall not exceed 3.0 g. This equates to: 3.9 cm² for glass 3 mm 3.0 cm² for glass 4 mm <p>Unlike UNECE Regulation No. 43 and Japan, no deviations are permitted.</p>

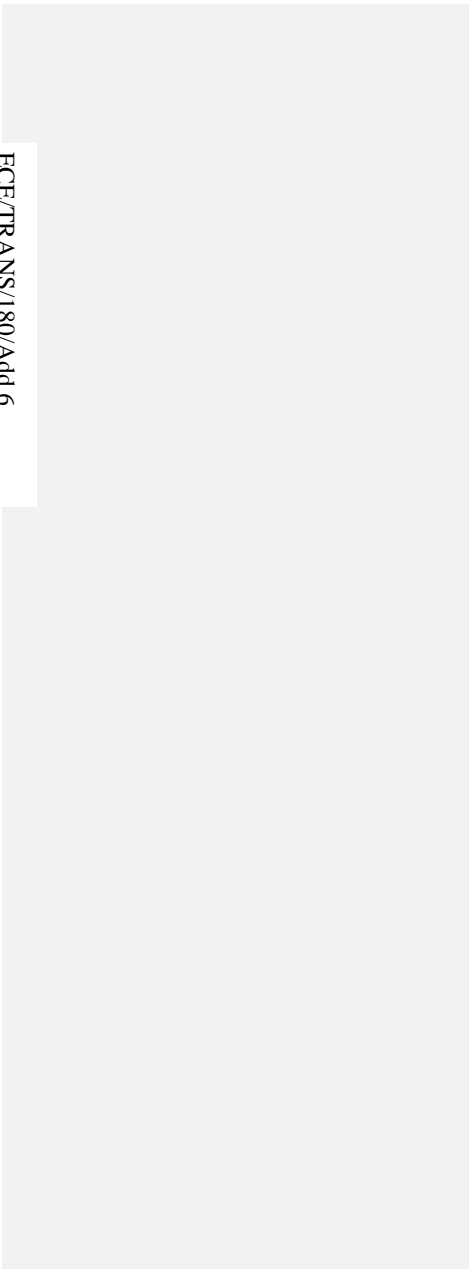

B. TEXT OF REGULATION

1. PURPOSE

This regulation specifies the requirements for safety glazing intended for installation in motor vehicles as original equipment or as replacement parts. Its purpose is:

- (a) To reduce the danger of bodily injury as far as possible in the event of shattering of a vehicle window;
- (a) To ensure that vehicle windows are sufficiently resistant to the incidents likely to occur in normal traffic, and to atmospheric and temperature conditions, chemical action, combustion and abrasion;
- (b) To ensure that windscreens are sufficiently transparent to ensure driver visibility and to allow the driver to see the road clearly enough to be able to brake and stop the vehicle in the event of windscreen shattering;
- (c) To minimize the possibility of occupants being thrown through vehicle windows in collisions.

2. APPLICATION/SCOPE

Kommentar [PA5]: See document
GRSG-107-23

This regulation applies to safety glazing intended for installation as windscreens or panes ~~use of double windows, each pane is considered a separate item of glazing panes~~ on Category 1 and 2 vehicles as defined in Special Resolution No. 1 (S.R.1) concerning the Common Definitions of Vehicle Categories, Masses and Dimensions, to the exclusion however of glazing for lighting and light-signalling devices and instrument panels, and of bullet resistant glazing. In the case of double windows, each pane is considered a separate item of glazing.

3. DEFINITIONS

- 3.1. Bullet resistant glazing means glazing constructed so as to be resistant to firearms.
- 3.2. Design glass outline means the design maximum unobstructed vehicle aperture designated to be glazed, before the glazing is installed or mounted, including all trims, but excluding obscuration bands.
- 3.3. Glazing means, for purposes of this regulation, the following materials.
 - 3.3.1. Double-glazed unit means an assembly of two panes permanently assembled in manufacture and separated by a gap.
 - 3.3.1.1. Symmetrical double-glazed unit means a double-glazed unit where the two component panes are identical (e.g., both toughened glass).
 - 3.3.1.2. Asymmetrical double-glazed unit means a double-glazed unit where the two component panes are not identical (e.g., one is toughened glass and the other is laminated glass).

- 3.3.2. Double window means an assembly of two individual panes separately installed within the same opening in the vehicle.
- 3.3.3. Glass-plastics means glazing consisting of any glazing material which comprises one layer of glass and one or more layers of plastic in which a plastic surface of the product faces the inner side.
- 3.3.4. Interlayer: means any material designed to be used to hold together the component layers of laminated-glass.
- 3.3.5. Laminated-glass: means glazing consisting of two or more layers of glass held together by one or more inter-layers of plastic material.
- 3.3.6. Glazing faced with plastics: means either toughened-glass or laminated-glass with a layer of plastic on the inner side.
- 3.3.7. Uniformly toughened-glass: means glazing consisting of a single layer of glass which has been subjected to special treatment to increase its mechanical strength and to condition its fragmentation after shattering.
- 3.4. Glazing requisite for driver visibility
- 3.4.1. Glazing requisite for the driver's forward field of vision: means all the glazing forward of a plane passing through the driver's "R" point and perpendicular to the longitudinal median plane of the vehicle, through which the driver can view the road when driving or manoeuvring the vehicle.
- 3.4.2. Glazing requisite for the driver's rearward field of vision: means all glazing rearward of a plane passing through the driver's "R" point and perpendicular to the longitudinal median plane of the vehicle, through which the driver can view the road when driving or manoeuvring the vehicle.
- 3.5. Height of segment "h": means the maximum distance, measured at right angles to the glazing, separating the inner surface of the glazing from a plane passing through the ends of the glazing. (see Annex 7.2., Figure 1)
- 3.6. Inner side: means the side of glazing which is facing towards the passenger compartment when the material is mounted in the vehicle.
- 3.7. Nominal thickness: means the manufacturer's design thickness with a tolerance of $\pm (n \times 0.2 \text{ mm})$ where n equals the number of glass layers in the glazing.
- 3.8. Opaque obscuration: means any area of the glazing preventing light transmission, including any screen-printed area, whether solid or dot-printed, but excluding any shade band.

- 3.9. Optical deviation means the angle between the true and the apparent direction of a point viewed through the windscreen, the magnitude of the angle being a function of the angle of incidence of the line of sight, the thickness and inclination of the windscreen, and the radius of curvature "r" at the point of incidence.
- 3.10. Optical distortion means an optical defect in a windscreen that changes the appearance of an object viewed through the windscreen.
- 3.11. Outer side means the side of glazing which is facing away from the passenger compartment when the material is mounted in the vehicle.
- 3.12. Pane means any single piece of glazing other than a windscreen.
- 3.12.1. Curved pane means a pane with a height of segment "h" greater than 10 mm per linear meter.
- 3.12.2. Flat pane means a pane with a height of segment equal to or less than 10 mm per linear meter.
- 3.13. Reference Points
- 3.13.1. Eye-Point means the "O" Point
- 3.13.2. "H" Point means the pivot centre of the torso and thigh of the 3 DH machine installed in the vehicle seat. The 3 DH machine corresponds to that described in ISO Standard 6549. The coordinates of the H point are determined in relation to the fiducial marks defined by the vehicle manufacturer, according to the three-dimensional system corresponding to ISO Standard 4130.
- 3.13.3. "O" Point means the point located 625 mm above the "R" Point of the driver's seat in the vertical plane parallel to the longitudinal median plane of the vehicle for which the windscreen is intended, passing through the axis of the steering wheel.
- 3.13.4. "R" Point or seating reference point, means the position of the H-point with the driver's seat in the design driving position as defined by the vehicle manufacturer.
- 3.13.5. Design seat-back angle means the angle between the vertical line through the R point and the torso line defined by the vehicle manufacturer.
- 3.14. Radius of curvature "r" means the smallest radius of arc of the glazing as measured in the most curved area.
- 3.15. Regular light transmittance means light transmittance measured perpendicularly to the glazing.
- 3.16. Sample means a specially prepared piece of glazing representative of a finished product or a piece cut from a finished product.

- 3.17. Secondary image means a spurious or ghost image, in addition to the bright primary image, usually seen at night when the object being viewed is very bright in relation to its surroundings, for example, the headlights of an approaching vehicle.
- 3.18. Secondary image separation means the angular distance between the position of the primary and secondary images.
- 3.19. Shade band means any area of the glazing with a reduced light transmittance, excluding any opaque obscuration.
- 3.20. Test piece means a sample or a finished product of glazing.
- 3.21. Transparent area of the windscreen means the glazing area contained within the design glass outline, excluding any allowed opaque obscuration (see para. 7.1.3.4.), but including any shade band.
- 3.22. Windscreen means the glazing in front of the driver through which the driver views the road ahead.
- 3.22.1. Inclination angle of a windscreen means the angle included between a vertical line and a straight line passing through the top and bottom edges of the inner side of the windscreen, when both lines are contained in the vertical plane through the longitudinal axis of the vehicle.
- 3.23. Overhead glazing means those glass panes fitted in a vehicle, located completely above a horizontal plane passing through the O-point of the driver and being part of the design glass outline.
Any backlights, front lights or side lights are excluded from this definition.
- 3.24. Overhead glazing zone: Area of the overhead glazing, not covered by structures and [25 mm] within the design glass outline with following additional size requirements
4. General requirements
- 4.1. Markings
- 4.1.1. General requirements for markings.
- 4.1.1.1. All marking shall be clearly legible from at least one side of the glazing, indelible, and at least 3 mm in height.
- 4.1.2. Identification marks.
Each piece of glazing shall bear the appropriate marks set out in this section.

Kommentar [m6]: Section 3.23: Change Proposal by Industry (OICA/ JAMA / ALLIANCE) discussed in 4th meeting IWG PSG as being in principle necessary

Kommentar [Korea7]: Agree with the definition

Kommentar [m8]:
Section 3.24: Change Proposal by Industry (OICA/ JAMA / ALLIANCE) discussed in 4th meeting IWG PSG

Kommentar [Korea9]: It would be better to deal with "overhead glazing zone" as a requirement in GTR structure. This definition is the same as a concept with design glass outline[3.2].

Kommentar [m10]: Area of markings needs to be updated to latest agreed level

- 4.1.2.1. Identification marks for windscreens.
 - 4.1.2.1.1. "II" for laminated-glass.
 - 4.1.2.1.2. "III" for glass-plastics.
- 4.1.2.2. Identification marks for panes.
 - 4.1.2.2.1. "I" for uniformly toughened glass.
 - 4.1.2.2.2. "IV" for laminated glass.
 - 4.1.2.2.3. "V" for a double glazed unit.
 - 4.1.2.2.4. "VI" for glass-plastics.
- 4.1.2.3. Additional identification marks.
 - 4.1.2.3.1. Glazing faced with plastic shall be marked with "/P" after the mark required by paragraph 4.1.2.1. or 4.1.2.2., e.g., II/P.
 - 4.1.2.3.2. Glazing with a light transmission of less than 70 per cent shall be marked with "/RLT" after the mark required by paragraph 4.1.2.2., e.g. I/RLT.
 - 4.1.2.3.3. If glazing requires both the "/P" and the "/RLT", the mark required by paragraph 4.1.2.3.1 shall precede the mark required by paragraph 4.1.2.3.2.
- 4.2. Particular provisions
 - 4.2.1. Installation

Each Contracting Party, as defined under the 1998 Agreement on global technical regulations (gtr), shall specify which type of glazing is allowed in which vehicles and at which locations.
 - 4.2.2. Headform test

Each Contracting Party, as defined under the 1998 Agreement on global technical regulations (gtr), may decide not to apply the provisions of paragraphs 5.4.3. and 5.5.3.2. under national or regional law.

5. Performance Requirements

	Windscreens			Panels (excluding overhead glazing)					
	Laminated glass		Glass plastics	Uniformly toughened glass		Laminated glass		Double glazed unit 1/	Glass plastics
Marking	II	II/P	III	I	I/P	IV	IV/P	V	VI
Light transmittance	5.1.1.	5.1.1.	5.1.1.	5.1.1.	5.1.1.	5.1.1.	5.1.1.	5.1.1.	5.1.1.
Resistance to abrasion	5.1.2.	5.1.2.	5.1.2.		5.1.2.	5.1.2.	5.1.2.		5.1.2.
Resistance to temperature changes		5.2.1.	5.2.1.		5.2.1.		5.2.1.		5.2.1.
Resistance to fire		5.2.2.	5.2.2.		5.2.2.		5.2.2.		5.2.2.
Resistance to chemicals		5.2.3.	5.2.3.		5.2.3.		5.2.3.		5.2.3.
Resistance to radiation	5.3.1.	5.3.1.	5.3.1.		5.3.1.	5.3.1.	5.3.1.		5.3.1.
Resistance to high temperature	5.3.2.	5.3.2.	5.3.2.		5.3.2.	5.3.2.	5.3.2.		5.3.2.
Resistance to humidity	5.3.3.	5.3.3.	5.3.3.		5.3.3.	5.3.3.	5.3.3.		5.3.3.
Optical distortion	5.4.1.	5.4.1.	5.4.1.						
Image separation	5.4.2.	5.4.2.	5.4.2.						
Fragmentation				5.5.1.1.	5.5.1.1.				
Head-form	5.4.3. 2/	5.4.3. 2/	5.4.3. 2/					5.5.3.2. 2/	
2,260 g Ball	5.4.4.	5.4.4.	5.4.4.						
227 g Ball	5.4.5.	5.4.5.	5.4.5.	5.5.1.2.	5.5.1.2.	5.5.2.1.	5.5.2.1.		5.5.2.1

Kommentar [m11]: Change Proposal by Industry (OICA/ JAMA / ALLIANCE) discussed in 4th meeting IWG PSG

	Overhead Glazing		Uniformly toughened glass		Laminated glass		Double glazed unit 1/	Glass plastics
	VII	VII/P	VIII	VIII/P	IX			
Light transmittance	5.1.1.	5.1.1.	5.1.1.	5.1.1.	5.1.1.	5.1.1.	5.1.1.	
Resistance to abrasion		5.1.2.	5.1.2.	5.1.2.			5.1.2.	
Resistance to temperature changes		5.2.1.		5.2.1.			5.2.1.	
Resistance to fire		5.2.2.		5.2.2.			5.2.2.	
Resistance to chemicals		5.2.3.		5.2.3.			5.2.3.	
Resistance to radiation		5.3.1.	5.3.1.	5.3.1.			5.3.1.	
Resistance to high temperature		5.3.2.	5.3.2.	5.3.2.			5.3.2.	
Resistance to humidity		5.3.3.	5.3.3.	5.3.3.			5.3.3.	
Optical distortion								
Image separation								
Fragmentation	5.5.1.1.	5.5.1.1.						
Head-form						5.5.3.2. 2/		
2,260 g Ball								
227 g Ball	5.6.1.	5.6.1.	5.6.1.	5.6.1.			5.6.1.	

Kommentar [m12]: Additional Testing Specification Matrix for Overhead Glazing Definition: Change Proposal by Industry (OICA/ JAMA / ALLIANCE) discussed in 4th meeting IWG PSG

Kommentar [Korea13]:
Light transmittance : to be exempted(as described in 5.1.1.1)
Resistance to abrasion : to be exempted
Resistance to temperature changes : not sure

- 1/ Each component pane shall satisfy the appropriate tests for the type of glazing.
2/ See paragraph 4.2.2.

Table 1 - Summary of performance requirements

5.1. Requirements applicable to all glazing

5.1.1. Light transmittance test

5.1.1.1. When tested in accordance with paragraph 6.11, the regular light transmittance of glazing requisite for the driver's forward field of vision shall not be less than 70 per cent.

5.1.1.2. When tested in accordance with paragraph 6.11., the regular light transmittance of glazing requisite for the driver's rearward field of vision may be less than 70 per cent, if not forbidden by the national legislation or regulation of Contracting Party.

5.1.1.3. Test pieces

5.1.1.3.1. Three test pieces shall be tested and each shall meet the requirements.

5.1.1.3.2. The test pieces shall be as described in paragraph 6.11.3.

5.1.2. Test of resistance to abrasion

5.1.2.1. Except as provided in paragraph 5.1.2.2., when tested in accordance with paragraph 6.6. for 1,000 cycles, light scatter shall not exceed 2 per cent.

5.1.2.2. For glazing faced with plastic, when tested on the inner side in accordance with paragraph 6.6. for 100 cycles, light scatter shall not exceed 4 per cent.

5.1.2.3. Test pieces

5.1.2.3.1. Three test pieces shall be tested and each shall meet the requirements.

5.1.2.3.2. The test pieces shall be as described in paragraph 6.6.

5.2. Requirements applicable to all glazing faced with plastic

5.2.1. Test of resistance to temperature changes.

5.2.1.1. When tested in accordance with paragraph 6.10. the test pieces shall not show any evidence of cracking, clouding, separation of layers or apparent deterioration.

5.2.1.2. Test pieces

- 5.2.1.2.1. Two test pieces shall be tested and each shall meet the requirements.
- 5.2.1.2.1. The test pieces shall be as described in paragraph 6.10.
- 5.2.2. Test of Resistance to Fire
 - 5.2.2.1. When tested in accordance with paragraph 6.14., the rate of burning shall not exceed 90 mm/min.
 - 5.2.2.2. Test pieces
 - 5.2.2.2.1. Five test pieces shall be tested and each shall meet the requirements.
 - 5.2.2.2.2. The test pieces shall be as described in paragraph 6.14.
- 5.2.3. Test of resistance to chemicals.
 - 5.2.3.1. When tested in accordance with paragraph 6.15. the test piece shall not exhibit any softening, tackiness, crazing, or apparent loss of transparency.
 - 5.2.3.2. Test pieces
 - 5.2.3.2.1. Four test pieces per chemical shall be tested and at least three shall meet the requirements.
 - 5.2.3.2.2. The test pieces shall be as described in paragraph 6.15.
- 5.3. Requirements applicable to all laminated-glass and all glazing faced with plastics
 - 5.3.1. Test of resistance to radiation
 - 5.3.1.1. When tested in accordance with paragraph 6.8., the total light transmittance when measured pursuant to paragraph 6.11. shall not fall below 95 per cent of the original value before irradiation and for glazing required to have a minimum light transmittance of 70 per cent, shall not fall below 70 per cent.
 - 5.3.1.2. Test pieces
 - 5.3.1.2.1. Three test pieces shall be tested and each shall meet the requirements.
 - 5.3.1.2.2. The test pieces shall be as described in paragraph 6.8.
 - 5.3.2. Test of Resistance to High Temperature.
 - 5.3.2.1. When tested in accordance with paragraph 6.7., no significant change, e.g., whitening, bubbles, or delamination, excepting surface cracks, shall form more than

15 mm from an uncut edge or 25 mm from a cut edge of the test piece or sample or more than 10 mm away from any cracks which may occur during the test.

5.3.2.2. Test pieces

5.3.2.2.1. Three test pieces shall be tested and each shall meet the requirements.

5.3.2.2.2. The test pieces shall be as described in paragraph 6.7.

5.3.3. Test of Resistance to Humidity

5.3.3.1. When tested in accordance with paragraph 6.9., at the time specified in paragraph 6.9.1.4. or 6.9.1.5., as appropriate, no significant change, e.g., whitening, bubbles, or delamination, excepting surface cracks, shall be observed more than 10 mm from the uncut edges and more than 15 mm from the cut edges.

5.3.3.2. Test pieces

5.3.3.2.1. Three test pieces shall be tested and each shall meet the requirements.

5.3.3.2.2. The test pieces shall be as described in paragraph 6.9.

5.4. Requirements applicable to windscreens

5.4.1. Optical distortion test.

When tested in accordance with paragraph 6.12. optical distortion shall not exceed the values given below for each zone or test area.

Vehicle category	Zone or test area	Maximum values of optical distortion
1-1 and 2 (based on a 1-1 where the windscreen and seating positions are identical)	A - extended according to paragraph 7.1.3.2.2.	2' of arc
	B - reduced according to paragraph 7.1.3.2.4.	6' of arc
1-2 and 2 (except those based on a 1-1 where the windscreen and seating position are identical)	I according to paragraph 7.1.3.3.2.	2' of arc

5.4.1.1. No measurements shall be made in a peripheral area 25 mm inboard of the design glass outline and of any opaque obscuration, provided that it does not impinge into the extended zone A or zone I.

5.4.1.2. In the case of split windscreens, no measurements shall be made in a strip 35 mm from the edge of the windscreen which is adjacent to the dividing pillar.

5.4.1.3. A maximum value of 6' of arc is permitted for all portions of Zone I or Zone A in

a peripheral area 100 mm inboard of the design glass outline.

5.4.1.4. Test pieces

5.4.1.4.1. Four windscreens shall be tested and each shall meet the requirements.

5.4.2. Secondary image separation test.

When tested in accordance with paragraph 6.13. separation of the primary and secondary image shall not exceed the values given below for each zone or test area.

Vehicle category	Zone or test area	Maximum values of the separation of the primary and secondary images
1-1 and 2 (based on a 1-1 where the windscreen and seating positions are identical)	A - extended according to paragraph 7.1.3.2.2. B - reduced according to paragraph 7.1.3.2.4.	15' of arc 25' of arc
1-2 and 2 (except those based on a 1-1 where the windscreen and seating position are identical)	I according to paragraph 7.1.3.3.2.	15' of arc

5.4.2.1. No measurements shall be made in a peripheral area 25 mm inboard of the design glass outline and of any opaque obscuration, provided that it does not impinge into the extended zone A or zone I.

5.4.2.2. In the case of split windscreens, no measurements shall be made in a strip 35 mm from the edge of the glass pane which is to be adjacent to the dividing pillar.

5.4.2.3. A maximum value of 25' of arc is permitted for all portions of Zone I or Zone A in a peripheral area 100 mm inboard of the design glass outline.

5.4.2.4. Test pieces

5.4.2.4.1. Four windscreens shall be tested and each shall meet the requirements.

5.4.3. Head-form test on windscreens

When tested in accordance with paragraph 6.5., at the drop height of 1.5 m \pm_{-5}^{+0} mm, the windscreen shall meet the following requirements:

5.4.3.1. The windscreen shall break displaying numerous circular cracks centred approximately on the point of impact, the cracks nearest to the point of impact being not more than 80 mm from it.

5.4.3.2. The layers of glass shall remain adhering to the interlayer. One or more partial separations from the interlayer with a distance of less than 4 mm in breadth, on either side of the crack, are allowed outside a circle of 60 mm diameter centred on the point of impact.

5.4.3.3. On the impact side:

5.4.3.3.1. The interlayer shall not be laid bare over an area of more than 20 cm².

5.4.3.3.2. A tear in the interlayer up to a length of 35 mm is allowed.

5.4.3.4. Test pieces

5.4.3.4.1. Eight windscreens shall be tested and at least seven shall meet the requirements.

5.4.4. 2,260 g ball test

When tested in accordance with paragraph 6.4., at the drop height of 4 m $^{+25}_{-0}$ mm, the ball shall not pass through the glazing within five seconds after the moment of impact.

5.4.4.1. Test pieces

5.4.4.1.1. Twelve test pieces shall be tested and at least eleven shall meet the requirements.

5.4.4.1.2. The test pieces shall be as described in paragraph 6.4.4.

5.4.5. 227 g ball test.

When tested in accordance with paragraph 6.3., at the temperature and drop height specified in paragraph 6.3.3.4., the test piece shall meet the following requirements:

5.4.5.1. The ball does not pass through the test piece.

5.4.5.2. The test piece does not break into separate pieces.

5.4.5.3. Tears in the interlayer are allowed provided that the ball does not pass through the test piece.

5.4.5.4. If the interlayer is not torn, the mass of fragments detached from the side of the glass opposite to the point of impact shall not exceed the applicable values specified in paragraph 6.3.3.4.

5.4.5.6. Test pieces

5.4.5.6.1. Ten test pieces shall be tested at each of the specified temperatures and at least eight of each ten shall meet the requirements.

5.4.5.6.2. The test pieces shall be as described in paragraph 6.3.4.

5.5. Requirements applicable to panes

5.5.1. Requirements applicable only to uniformly toughened glass panes.

5.5.1.1. Fragmentation test

When tested in accordance with paragraph 6.2., at the points specified in paragraph 6.2.2.2., uniformly toughened glass shall fragment as follows:

5.5.1.1.1. The number of fragments in any 5 cm x 5 cm square shall not be less than 40.

5.5.1.1.2. For the purposes of this requirement, a fragment extending across at least one side of a square shall count as half a fragment.

5.5.1.1.3. When a fragment extends beyond the excluded area only the part of the fragment falling outside of the area shall be assessed.

5.5.1.1.4. Fragments of an area exceeding 3 cm² shall not be allowed except in the parts defined in paragraph 6.2.2.3.

5.5.1.1.5. No fragment longer than 100 mm in length shall be allowed except in the areas defined in paragraph 6.2.2.3. provided that:

5.5.1.1.5.1. Fragment ends do not converge to a point.

5.5.1.1.5.2. If they extend to the edge of the pane they do not form an angle of more than 45° to it.

5.5.1.1.6. Test pieces

5.5.1.1.6.1. Four panes shall be tested from each point of impact and at least three shall meet the requirements.

5.5.1.2. 227 g ball test

When tested in accordance with paragraph 6.3., at the drop height specified in paragraph 6.3.3.2., the test piece shall not break.

5.5.1.2.1. Test pieces

5.5.1.2.1.1. Six test pieces shall be tested and at least five shall meet the requirements.

5.5.1.2.1.2. The test pieces shall be as described in paragraph 6.3.4.

5.5.2. Requirements applicable only to laminated-glass and glass-plastic panes.

- 5.5.2.1. 227 g ball test
When tested in accordance with paragraph 6.3., at the drop height specified in paragraph 6.3.3.3., the test piece shall meet the following requirements:
- 5.5.2.1.1. The ball shall not pass through the test piece.
- 5.5.2.1.2. The laminate shall not break into separate pieces.
- 5.5.2.1.3. At the point immediately opposite the point of impact, small fragments of glass may leave the specimen, but the small area thus affected shall expose less than 645 mm² of reinforcing or strengthening material, the surface of which shall always be well covered with tiny particles of tightly adhering glass. Total separation of glass from the reinforcing or strengthening material shall not exceed 1935 mm² on either side.
- Spalling of the outer glass surface opposite the point of impact and adjacent to the area of impact is not to be considered a failure.
- 5.5.2.1.4. Test pieces
- 5.5.2.1.4.1. Eight test pieces shall be tested and at least six shall meet the requirements.
- 5.5.2.1.4.2. The test pieces shall be as described in paragraph 6.3.4.
- 5.5.3. Requirements applicable only to double-glazed units.
- 5.5.3.1. Individual components
- Each component pane forming the double-glazed unit shall be separately subjected to the requirements set out in paragraph 6. as appropriate for that type of glazing.
- 5.5.3.2. Head-form test
- When tested in accordance with paragraph 6.5., at a drop height of 1.50 m $^{+0}_{-3}$ mm, the test pieces shall meet following requirements:
- 5.5.3.2.1. A double-glazed unit consisting of two uniformly toughened-glass panes shall break.
- 5.5.3.2.2. A double-glazed unit consisting of laminated-glass panes and/or glass-plastics panes shall meet the following requirements:
- 5.5.3.2.2.1 The two components of the test piece yield and break, displaying numerous circular cracks centred approximately on the point of impact;

- 5.5.3.2.2.2. Tears in the interlayer(s) are allowed provided that the head-form does not pass through the test piece;
- 5.5.3.2.2.3. No fragment larger than 10 cm² becomes detached from the interlayer.
- 5.5.3.2.3. A double-glazed unit consisting of a uniformly toughened-glass pane and of a laminated-glass pane or glass-plastics pane shall meet the following requirements:
 - 5.5.3.2.3.1. The uniformly toughened glass pane breaks;
 - 5.5.3.2.3.2. The laminated-glass pane or glass-plastics pane:
 - 5.5.3.2.3.2.1. Yields and breaks, displaying numerous circular cracks centred approximately on the point of impact;
 - 5.5.3.2.3.2.2. Tears in the interlayer(s) are allowed provided that the head-form does not pass through the test piece;
 - 5.5.4.2.3.2.3. No fragment larger than 10 cm² becomes detached from the interlayer.
- 5.5.3.2.4. Test pieces
 - 5.5.3.2.4.1. Twelve test pieces shall be tested and at least eleven shall meet the requirements.
 - 5.5.3.2.4.2. The test pieces shall be as described in paragraph 6.5.5.1.
 - 5.5.3.2.4.3. In the case of an asymmetrical double-glazed unit, six tests shall be carried out on one side and six tests on the other side.

5.6. Requirements applicable to overhead glazing

For the overhead glazing, the fragmentation requirements according to para. 5.5.1.1 are applicable for uniformly toughened glass panes.

For the overhead glazing, the 227 g ball requirements according to para. 5.6.1 are applicable to all different glass materials used within the overhead glazing zone.

5.6.1. 227 g ball test

When tested in accordance with paragraph 6.3., at the drop height specified in paragraph 6.3.3.2., the test piece shall not break.

5.6.1.1. Test pieces

5.6.1.1.1. Six test pieces shall be tested and at least five shall meet the requirements.

5.6.1.1.2. The test pieces shall be as described in paragraph 6.3.4.

Kommentar [m14]: Section 5.6: Change Proposal by Industry (OICA/JAMA / ALLIANCE) discussed in 4th meeting IWG PSG due to additional definition of Overhead Glazing

6. TEST CONDITIONS AND PROCEDURES

6.1. Test conditions

Unless specified otherwise, the test conditions shall be as follows:

6.1.1. Temperature: $20 \pm 5^{\circ}\text{C}$.

6.1.2. Pressure: 860 to 1060 mbar.

6.1.3. Relative humidity: 60 ± 20 per cent.

6.2. Fragmentation test

6.2.1. Apparatus

6.2.1.1. To obtain fragmentation, a spring-loaded centre punch or a hammer of $75 \text{ g} \pm 5\text{g}$, each with a point having a radius of curvature of $0.2 \pm 0.05 \text{ mm}$, shall be used.

6.2.2. Procedure

6.2.2.1. The test piece to be tested shall not be rigidly secured; it may however be fastened on an identical test piece by means of adhesive tape applied all round the edge.

6.2.2.2. One test shall be carried out at each of the prescribed point of impact.

6.2.2.3. Fragmentation shall not be checked in a strip 2 cm wide round the edge of the samples, this strip representing the frame of the glass, nor within a radius of 7.5 cm from the point of impact.

6.2.2.4. Examination of the fragmentation pattern shall start within 10 seconds and shall be completed within 3 minutes after the impact.

6.2.3. Points of impact for uniformly toughened glass panes

They are as follows, and represented in Annex 7.2. , Figures 2(a), 2(b) and 2(c)

6.2.3.1. Point 1: in the geometric centre of the glass.

6.2.3.2. Point 2: for curved glass panes only; this point shall be selected on the largest median in that part of the pane where the radius of curvature "r" of the glazing is less than 200 mm.

6.2.3.3. Test pieces

6.2.3.3.1. Four panes for each point of impact.

6.3. 227 g ball test

6.3.1. Apparatus

6.3.1.1. Solid, smooth, hardened-steel ball with a mass of $227 \text{ g} \pm 2 \text{ g}$.

6.3.1.2. Means for dropping the ball freely from the height in paragraph 6.3.3., or a means for giving the ball a velocity equivalent to that obtained by the free fall. When a device to project the ball is used, the tolerance on velocity shall be ± 1 per cent of the velocity equivalent to that obtained by the free fall.

6.3.1.3. Supporting fixture, such as that shown in Figure 1, composed of steel frames, with machined borders 15 mm wide, fitting one over the other and faced with rubber gaskets 3 mm thick and 15 mm wide and of hardness 50 ± 10 International Rubber Hardness Degree (IRHD).

The lower frame rests on a steel box 150 mm high. The test piece is held in place by the upper frame, the mass of which is 3 kg. The supporting frame is welded onto a sheet of steel 12 mm thick resting on the floor with an interposed sheet of rubber 3 mm thick and of hardness 50 ± 10 IRHD.

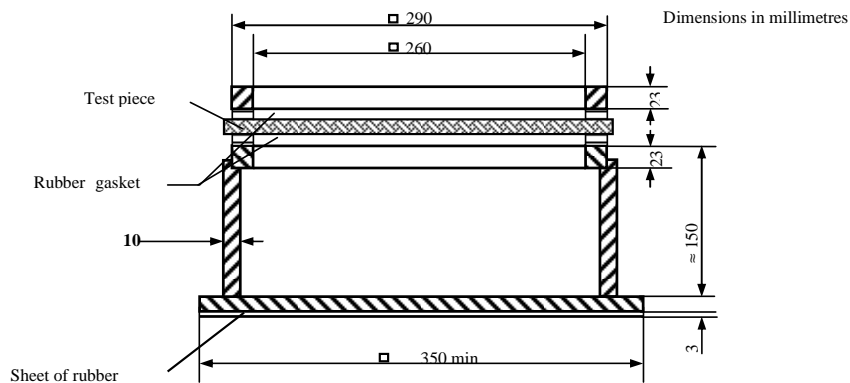
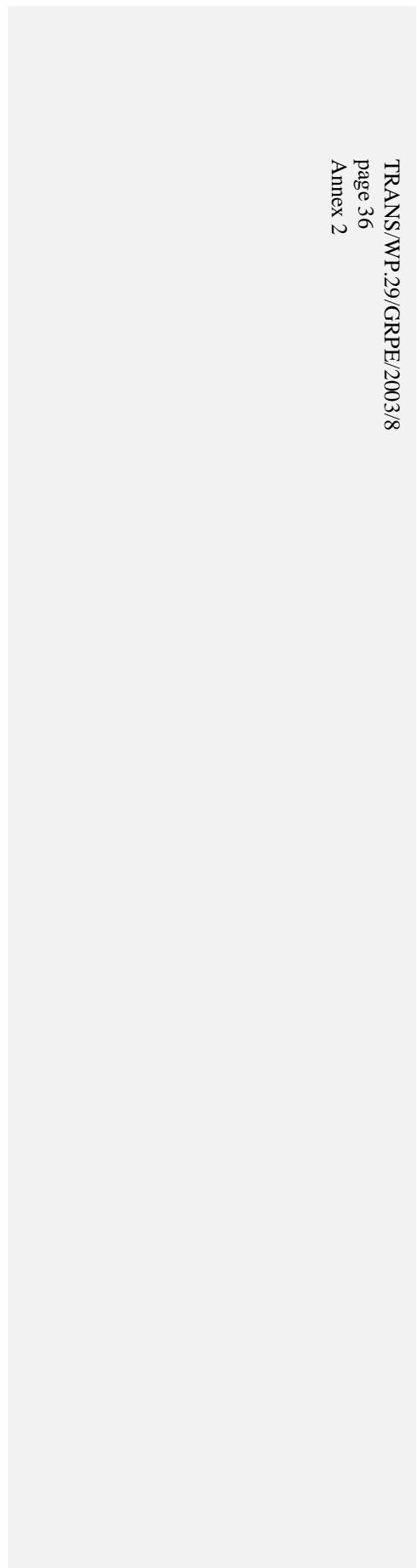

Figure 1: Support for ball tests



6.3.2. Procedure

6.3.2.1. Condition the test piece at the temperature specified in paragraph 6.1.1. for at least four hours immediately preceding the test. In the case of laminated-glass and glass-plastic windscreens the temperatures will be as specified in 6.3.3.4.

6.3.2.2. Place the test piece in the fixture described in paragraph 6.3.2.3. The plane of the test piece shall be perpendicular, within 3°, to the incident direction of the ball.

6.3.2.3. The point of impact shall be within 25 mm of the geometric centre of the test piece supported-area for a drop height less than or equal to 6 m, and within 50 mm of the centre of the test piece supported-area for a drop height greater than 6 m.

Kommentar [m15]: Agreed in 3rd meeting IWG PSG to update GTR6 to correct former level according to CLEPA proposal = see document GRSG-107-23

6.3.2.4. The ball shall strike the outer face of the test piece.

6.3.2.5. The ball shall make only one impact.

Kommentar [Korea16]: This amendment should be implemented in accordance with CPA limitation.

6.3.3. Drop height

6.3.3.1. The drop height shall be measured from the under-face of the ball to the upper face of the test piece.

6.3.3.2. For uniformly toughened glass panes, the drop height shall be 2.0 m^{+5}_{-0} mm.

6.3.3.3. For laminated-glass and glass-plastic panes, the drop height shall be 9 m^{+25}_{-0} mm.

6.3.3.4. For laminated-glass and glass-plastic windscreens, the drop height and the mass of the detached fragments shall be as indicated in the following table, where e equals the nominal thickness of the specimen being tested. A tolerance of $^{+25}_{-0}$ mm is allowed in the height of fall. Ten test pieces shall be tested at a temperature of $+40 \pm 2^\circ\text{C}$ and ten at a temperature of $-20 \pm 2^\circ\text{C}$.

Nominal thickness of test pieces mm	+ 40 ± 2°C		- 20 ± 2°C	
	Height of fall M	Maximum permitted mass of the fragments g	Height of fall m	Maximum permitted mass of the fragments g
e ≤ 4.5	9	12	8.5	12
4.5 < e ≤ 5.5	9	15	8.5	15
5.5 < e ≤ 6.5	9	20	8.5	20
e > 6.5	9	25	8.5	25

6.3.4. Test pieces

6.3.4.1. The test pieces shall be flat samples measuring 300 x 300 mm, specially made or cut from the flattest part of a windscreen or pane.

~~The test piece shall be as defined in paragraph 7.2. in the case that the following toughened glass of vehicles is exposed to the inside of vehicle:~~

- ~~a) Sunroofs and panoramic sunroofs~~
- ~~b) The roof of vehicle~~

The test piece shall be as defined in paragraph 7.2. in the case that the following toughened glass of vehicles is used in overhead glazing zone.

6.3.4.2. Test pieces can alternatively be finished products that may be supported over the apparatus described in paragraph 6.3.1.

6.3.4.3. If the test pieces are curved, care should be taken to ensure adequate contact with the support.

6.4. 2,260 g ball test

6.4.1. Apparatus

6.4.1.1. Solid hardened-steel ball with a mass of 2,260 g ± 20 g.

6.4.1.2. Means for dropping the ball freely from the height specified in paragraph 6.4.2.7. or means for giving the ball a velocity equivalent to that obtained by the free fall. When a device to project the ball is used, the tolerance on velocity shall be ± 1 per cent of the velocity equivalent to that obtained by the free fall.

6.4.1.3. The supporting fixture shall be as shown in Figure 1 and identical with that described in paragraph 6.3.1.3.

6.4.2. Procedure

6.4.2.1. Condition the test piece at the temperature specified in paragraph 6.1.1. for at least four hours immediately preceding the test.

6.4.2.2. Place the test piece in the supporting fixture. The plane of the test piece shall be perpendicular within 3°, to the incident direction of the ball.

6.4.2.3. In the case of glass-plastics glazing the test piece shall be clamped to the support. All other glazing shall not be clamped.

6.4.2.4. The point of impact shall be within 25 mm of the geometric centre of the test piece.

6.4.2.5. The ball shall strike the inner face of the test piece.

Formatiert: Durchgestrichen

Kommentar [m17]: Change Proposal by KOREA discussed in 4th meeting IWG PSG

Kommentar [Korea18]: The previous proposal is to be struck out

Formatiert: Durchgestrichen

Kommentar [Korea19]: The "following" is not needed here.

Kommentar [m20]: Adapted Change Proposal of KOREA by Industry presented in 4th meeting IWG PSG using new definition of overhead glazing

Kommentar [Korea21]:
(Alternative)
... in the case that the toughened glass of overhead glazing is exposed to inside.

- 6.4.2.6. The ball shall make only one impact.
- 6.4.3. Drop height
 - 6.4.3.1. The drop height shall be measured from the under face of the ball to the upper face of the test piece.
 - 6.4.3.2. The drop height shall be $4.0 \text{ m}^{+5}_{-0} \text{ mm}$.
- 6.4.4. Test pieces
 - 6.4.4.1. The test pieces shall be flat samples measuring 300 x 300 mm, specially made or cut from the flattest part of a windscreen.
 - 6.4.4.2. Test pieces can alternatively be finished products that may be supported over the apparatus described in paragraph 6.3.1.
 - 6.4.4.3. If the test pieces are curved, care should be taken to ensure adequate contact with the support.
- 6.5. Head-form tests
 - 6.5.1. Apparatus
 - 6.5.1.1. Head-form
 - 6.5.1.1.1. Spherical or semi-spherical head-form made of laminated hardwood covered with replaceable felt and with or without a crossbeam made of wood. There is a neck-shaped intermediate piece between the spherical part and the crossbeam and a mounting rod on the other side of the crossbeam.

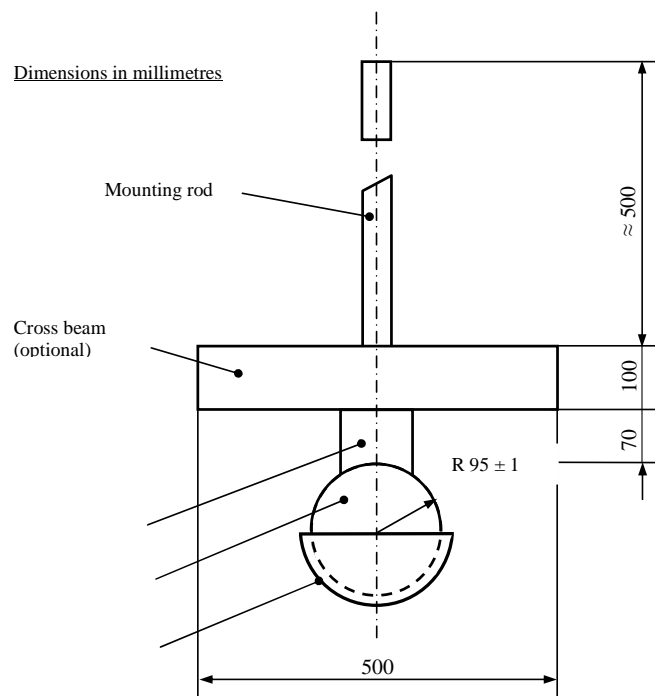

Figure 2: Head-form

Intermediate
piece

Head

Felt cover
5 mm thick

6.5.1.1.2. The dimensions shall be in accordance with Figure 2.

6.5.1.1.3. The total mass of the head-form shall be 10 ± 0.2 kg.

6.5.1.2. Means for dropping the head-form freely from a height to be specified, or means for giving the head-form a velocity equivalent to that obtained by the free fall. When a device to project the head-form is used, the tolerance on velocity shall be $\pm 1\%$ of the velocity equivalent to that obtained by the free fall.

6.5.1.3. Supporting fixture, as shown in Figure 3, for testing flat test pieces.

The fixture is composed of two steel frames, with machined borders 50 mm wide, fitting one over the other and faced with rubber gaskets 3 mm thick and 15 ± 1 mm wide and of hardness 70 ± 10 IRHD. The upper frame is held pressed against the lower frame by at least eight bolts. The torque on the bolts shall ensure that the movement of the test piece during the test will not exceed 2 mm.

Dimensions in millimeters

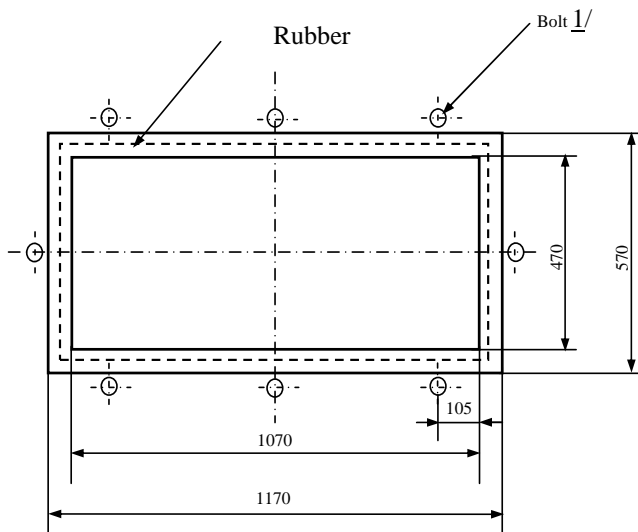

1/ The minimum recommended torque for M20 is 30Nm.

Figure 3: Head-form test support for flat samples

6.5.1.4. Supporting fixture for windscreens

The support shall consist of a rigid piece corresponding to the shape of the windscreen so that the head-form strikes the inner face of the windscreen. It has an interposed strip of rubber of hardness 70 ± 10 IRHD, thickness 3 mm and width 15 mm. The support shall rest on a rigid stand with an interposed sheet of rubber of hardness 70 ± 10 IRHD and thickness 3 mm.

6.5.2. Procedure for tests on flat test pieces.

6.5.2.1. Condition the test piece at the temperature specified in paragraph 6.1.1. for at least four hours immediately preceding the test.

6.5.2.2. Fix the test piece in the supporting frame described in paragraph 6.5.1.3.

6.5.2.3. The plane of the test piece shall be perpendicular within 3° , to the incident direction of the head-form.

6.5.2.4. The head-form shall strike the test piece within 40 mm of its geometric centre on its inner face.

6.5.2.5. The head-form shall make only one impact.

6.5.2.6. The impact surface of the felt cover shall be replaced after each successive 12 tests.

6.5.3. Procedure for tests on windscreens

6.5.3.1. Condition the test piece at the temperature specified in paragraph 6.1.1. for at least four hours immediately preceding the test.

6.5.3.2. Place the windscreen freely on a supporting fixture as described in paragraph 6.5.1.4.

6.5.3.3. The plane of the windscreen shall be perpendicular within 3° , to the incident direction of the head-form.

6.5.3.4. The head-form shall strike the windscreen within 40 mm of its geometric centre on its inner face.

6.5.3.5. The head-form shall make only one impact.

6.5.3.6. The impact surface of the felt cover shall be replaced after each successive 12 tests.

6.5.4. Drop height

6.5.4.1. The drop height shall be measured from the under-face of the head-form to the upper face of the test piece.

- 6.5.4.2. It shall be $1.5 \text{ m} \begin{smallmatrix} +0 \\ -3 \end{smallmatrix}$ mm for tests conducted on windscreens and on flat samples for double glazed units.
- 6.5.5. Test pieces
- 6.5.5.1. The test pieces according to paragraph 6.5.2. shall be flat samples measuring $1,100 \times 500 \text{ mm} \begin{smallmatrix} +10 \\ -2 \end{smallmatrix}$ mm.
- 6.5.5.2. The test pieces according to paragraph 6.5.3. shall be windscreens.
- 6.6. Test of resistance to abrasion
- 6.6.1. Apparatus
- 6.6.1.1. Abrading instrument as shown in Figure 4 2/ and consisting of:
- 6.6.1.1.1. A horizontal turntable, with centre clamp, which revolves counter-clockwise at 65 to 75 rev/min.
- 6.6.1.1.2. Two weighted parallel arms each carrying a special abrasive wheel freely rotating on a ball-bearing horizontal spindle; each wheel rests on the test specimen under the pressure exerted by a mass of 500 g.
- 6.6.1.1.3. The turntable of the abrading instrument shall rotate regularly, substantially in one plane (the deviation from this plane shall not be greater than ± 0.05 mm at a distance of 1.6 mm from the turntable periphery).
- 6.6.1.1.4. The wheels shall be mounted in such a way that when they are in contact with the rotating test piece they rotate in opposite directions so as to exert, twice during each rotation of the test piece, a compressive and abrasive action along curved lines over an annular area of about 30 cm^2 .

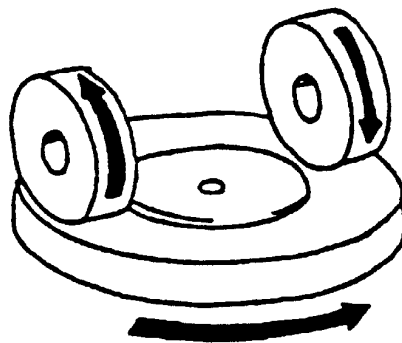

2/ An example of a suitable abrading instrument is that supplied by Teledyne Taber (United States of America).

Figure 4 Diagram of abrading instrument

Figure 4: Diagram of abrading instrument

- 6.6.1.2. Abrasive wheels ^{3/}, each 45 to 50 mm in diameter and 12.5 mm thick, composed of a special finely-screened abrasive embedded in a medium hard rubber.
 - 6.6.1.2.1. The wheels shall have a hardness of 72 ± 5 IRHD, as measured at four points equally spaced on the centreline of the abrading surface, the pressure being applied vertically along a diameter of the wheel and the readings being taken 10 seconds after full application of the pressure.
 - 6.6.1.2.2. The abrasive wheels shall be prepared for use by very slow rotation against a sheet of flat glass to ensure that their surface is completely even.
- 6.6.1.3. Light source consisting of an incandescent lamp with its filament contained within a parallelepiped measuring 1.5 mm x 1.5 mm x 3 mm. The voltage at the lamp filament shall be such that the colour temperature is $2,856 \pm 50$ K. This voltage shall be stabilised within $\pm 1/1000$.
- 6.6.1.4. Optical system consisting of a lens with a focal length f of at least 500 mm and corrected for chromatic aberrations.
 - 6.6.1.4.1. The full aperture of the lens shall not exceed $f/20$.
 - 6.6.1.4.2. The distance between the lens and the light source shall be adjusted in order to obtain a light beam which is substantially parallel.
 - 6.6.1.4.3. A diaphragm shall be inserted to limit the diameter of the light beam to 7 ± 1 mm. This diaphragm shall be situated at a distance of 100 ± 50 mm from the lens on the side remote from the light source.

^{3/} An example of suitable abrasive wheels are those that can be obtained from Teledyne Taber (United States of America).

- 6.6.1.5. Equipment for measuring scattered light (Figure 5), consisting of a photoelectric cell with an integrating sphere 200 to 250 mm in diameter. The sphere shall be equipped with entrance and exit ports for the light. The entrance port shall be circular and have a diameter at least twice that of the light beam. The exit port of the sphere shall be provided with either a light trap or a reflectance standard, according to the procedure described in paragraph 6.6.2.6. below. The light trap shall absorb all the light when no test piece is inserted in the light beam.
- 6.6.1.5.1. The axis of the light beam shall pass through the centre of the entrance and exit ports. The diameter b of the light-exit port shall be equal to $2 a \tan 4^\circ$, where a is the diameter of the sphere. The photoelectric cell shall be mounted in such a way that it cannot be reached by light coming directly from the entrance port or from the reflectance standard.
- 6.6.1.5.2. The surfaces of the interior of the integrating sphere and the reflectance standard shall be of substantially equal reflectance and shall be matte and non-selective.
- 6.6.1.5.3. The output of the photoelectric cell shall be linear within ± 2 per cent over the range of luminous intensities used. The design of the instrument shall be such that there is no galvanometer deflection when the sphere is dark.
- 6.6.1.5.4. The whole apparatus shall be checked at regular intervals by means of calibration standards of defined haze.

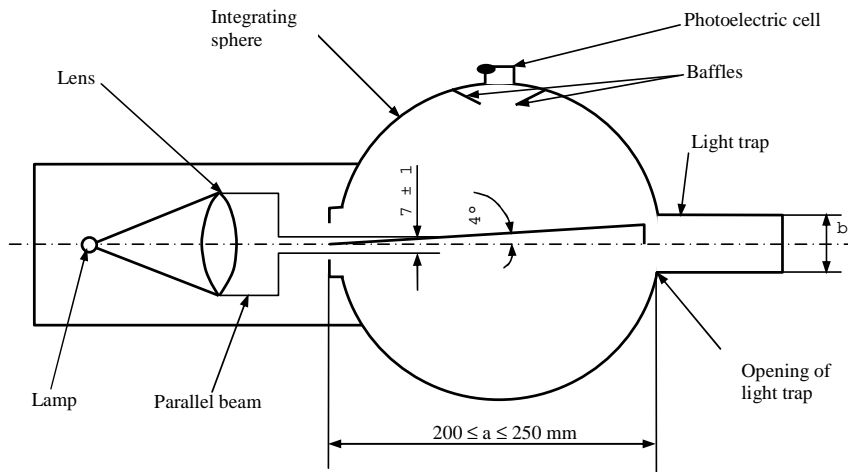

Figure 5: Hazemeter

- 6.6.2. Procedure

- 6.6.2.1. The abrasion test shall be carried out on that surface of the test piece which represents the outer side of the glass pane and also on the inner side if of plastics material.
- 6.6.2.2. Immediately before and after the abrasion, clean the test pieces in the following manner:
- (a) Wipe with a linen cloth under clean running water;
 - (b) Rinse with distilled or demineralised water;
 - (c) Blow dry with oxygen or nitrogen;
 - (d) Remove possible traces of water by dabbing softly with a damp linen cloth. If necessary, dry by pressing lightly between two linen cloths.

Any treatment with ultrasonic equipment is prohibited.

- 6.6.2.3. After cleaning, the test pieces shall be handled only by their edges and shall be stored to prevent damage to, or contamination of, their surfaces.
- 6.6.2.4. Recondition the test pieces as specified in paragraph 6.1. for a minimum time of 48 hours.
- 6.6.2.5. Immediately place the test piece against the entrance port of the integrating sphere. The angle between the normal (perpendicular) to the surface of the test piece and the axis of the light beam shall not exceed 8°.

- 6.6.2.6. Take four readings as indicated in the following table:

Reading	With test piece	With light trap	With reflectance standard	Quantity represented
T ₁	No	No	Yes	Incident light
T ₂	Yes	No	Yes	Total light transmitted by test piece
T ₃	No	Yes	No	Light scattered by instrument
T ₄	Yes	Yes	No	Light scattered by instrument and test piece

- 6.6.2.7. Repeat readings for T₁, T₂, T₃ and T₄ with other specified positions of the test piece to determine uniformity.

- 6.6.2.8. Calculate the total transmittance $T_t = T_2 / T_1$.

- 6.6.2.9. Calculate the diffuse transmittance T_d as follows: $T_d = \frac{T_4 - T_3(T_2 / T_1)}{T_1 - T_3}$

- 6.6.2.10. Calculate the percentage haze, or light, or both, scattered, as follows:
- 6.6.2.11. Haze, or light or both, scattered = $\frac{T_d}{T_i} \times 100\%$
- 6.6.2.12. Measure the initial haze of the test piece at a minimum of four equally spaced points in the unabraded area in accordance with the formula above. Average the results for each test piece. In lieu of the four measurements, an average value may be obtained by rotating the piece uniformly at 3 rev/sec or more.
- 6.6.2.13. For each type of safety glazing, carry out three tests with the same load. Use the haze as a measure of the subsurface abrasion, after the test piece has been subjected to the abrasion test.
- 6.6.2.14. Measure the light scattered by the abraded track at a minimum of four equally spaced points along the track in accordance with the formula above. Average the results for each test piece. In lieu of the four measurements, an average value may be obtained by rotating the piece uniformly at 3 rev/sec or more.
- 6.6.3. Test Pieces
- 6.6.3.1. The test pieces shall be flat samples measuring 100 x 100 mm.
- 6.7. Test of resistance to high temperature
- 6.7.1. Procedure
- 6.7.1.1. Heat to 100 °C.
- 6.7.1.2. Maintain this temperature for a period of two hours, then allow the test pieces to cool to the temperature specified in paragraph 6.1.1.
- 6.7.1.3. If the test piece has both external surfaces of inorganic material, the test may be carried out by immersing the test piece vertically in boiling water for the specified period of time, care being taken to avoid undue thermal shock.
- 6.7.2. Test pieces
- 6.7.2.1. The test pieces shall be flat samples measuring 300 x 300 mm, which have been specially made or cut from the flattest part of three windscreens or three panes, as the case may be, one edge of which corresponds to the upper edge of the glazing.

6.8. Test of resistance to radiation

6.8.1. Apparatus

6.8.1.1. Radiation source consisting of a medium-pressure mercury-vapour arc lamp with a tubular quartz bulb of ozone-free type; the bulb axis shall be vertical. The nominal dimensions of the lamp shall be 360 mm in length by 9.5 mm in diameter. The arc length shall be 300 ± 4 mm. The lamp shall be operated at 750 ± 50 W.

Any other source of radiation which produces the same effect as the lamp specified above may be used. To check that the effects of another source are the same, a comparison shall be made by measuring the amount of energy emitted within a wavelength range of 300 to 450 nanometres, all other wavelengths being removed by the use of suitable filters.

6.8.1.2. Power-supply transformer and capacitor capable of supplying to the lamp specified in paragraph 6.8.1.1. a starting peak voltage of 1,100 V minimum and an operating voltage of 500 ± 50 V.

6.8.1.3. Device for mounting and rotating the test pieces at 1 to 5 rev/min about the centrally-located radiation source in order to ensure even exposure.

6.8.2. Procedure

6.8.2.1. Check the regular light transmittance, determined according to paragraph 6.11., of three test pieces before exposure. Protect a portion of each test piece from the radiation, and then place the test pieces in the test apparatus 230 mm from and parallel lengthwise to the lamp axis. Maintain the temperature of the test pieces at 45 ± 5 °C throughout the test.

6.8.2.2. That face of the test piece which would constitute the outer face of the glazing shall face the lamp.

6.8.2.3. The exposure time shall be 100 hours. Each test piece shall be subjected to radiation such that the radiation on each point of the test piece produces on the interlayer the same effect as that which would be produced by solar radiation of $1,400 \text{ W/m}^2$ for 100 hours.

6.8.2.4. After exposure, measure the regular light transmittance again in the exposed area of each test piece.

6.8.3. Test pieces

6.8.3.1. The test pieces shall be flat samples measuring 76 x 300 mm or 300 x 300 mm, which have been specially made or cut from three windscreens or three panes, as the case may be, one edge of which corresponds to the upper edge of the glazing.

6.9. Test of resistance to humidity

6.9.1. Procedure

- 6.9.1.1. Keep samples in a vertical position for two weeks in a closed container in which the temperature is maintained at 50 ± 2 °C and the relative humidity at 95 ± 4 per cent.
- 6.9.1.2. If several test pieces are tested at the same time, spacing shall be provided between them.
- 6.9.1.3. Precautions shall be taken to prevent condensate from the walls or ceiling of the test chamber from falling on the test pieces.
- 6.9.1.4. Before assessment, laminated-glass test pieces shall have been maintained for two hours in the conditions specified in paragraph 6.1.
- 6.9.1.5. Before assessment, test pieces of glass faced with plastic and of glass-plastics shall have been maintained for 48 hours in the conditions specified in paragraph 6.1.

6.9.2. Test pieces

- 6.9.2.1. The test pieces shall be samples measuring 300 x 300 mm, which have been specially made or cut from three windscreens or three panes, as the case may be. One edge at least shall correspond to an edge of the glazing.

6.10. Test of resistance to temperature changes

6.10.1. Procedure

- 6.10.1.1. Test pieces shall be placed in an enclosure at a temperature of $-40^{\circ}\text{C} \pm 5$ °C for a period of 6 hours; they shall then be placed in the open air at a temperature of $23^{\circ}\text{C} \pm 2$ °C for one hour or until temperature equilibrium has been reached by the test pieces.
- 6.10.1.2. Test pieces shall then be placed in circulating air at a temperature of $+72^{\circ}\text{C} \pm 2$ °C for 3 hours.
- 6.10.1.3. After being placed again in the open air at $+23^{\circ}\text{C} \pm 2$ °C and cooled to that temperature, the test pieces shall be examined.

6.10.2. Test pieces

- 6.10.2.1. The test pieces shall be flat samples measuring 300 x 300 mm, which have been specially made or cut from three windscreens or panes, as the case may be.

6.11. Light transmittance test

6.11.1. Apparatus

6.11.1.1. Light source consisting of an incandescent lamp with its filament contained within a parallelepiped measuring 1.5 mm x 1.5 mm x 3 mm. The voltage at the lamp filament shall be such that the colour temperature is $2,856 \pm 50$ K. This voltage shall be stabilised within $\pm 1/1,000$.

6.11.1.2. Optical system consisting of a lens with a focal length f of at least 500 mm.

6.11.1.2.1. The full aperture of the lens shall not exceed $f/20$.

6.11.1.2.2. The distance between the lens and the light source shall be adjusted in order to obtain a light beam which is parallel.

6.11.1.2.3. A diaphragm shall be inserted to limit the diameter of the light beam to 7 ± 1 mm. This diaphragm shall be situated at a distance of 100 ± 50 mm from the lens on the side remote from the light source. The point of measurement shall be taken at the centre of the light beam.

6.11.1.3. Measuring equipment

6.11.1.3.1. The receiver shall have a relative spectral sensitivity in substantial agreement with the relative spectral luminous efficiency for the ICI ^{4/} standard photometric observer for photocopy vision. The sensitive surface of the receiver shall be covered with a diffusing medium and shall have at least twice the cross-section of the light beam emitted by the optical system. If an integrating sphere is used, the aperture of the sphere shall have a cross-sectional area at least twice that of the parallel portion of the beam.

6.11.1.3.2. The linearity of the receiver and the associated indicating instrument shall be within 2 per cent of the effective part of the scale.

6.11.1.3.3. The receiver shall be centred on the axis of the light beam.

6.11.2. Procedure

6.11.2.1. The sensitivity of the measuring system shall be adjusted in such a way that the instrument indicating the response of the receiver indicates 100 divisions when the safety glazing material is not inserted in the light path. When no light is falling on the receiver, the instrument shall read zero.

6.11.2.2. Place the glazing at a distance from the receiver equal to five times the diameter of the receiver. Insert the glazing between the diaphragm and the receiver and adjust its

^{4/} International Commission on Illumination.

orientation in such a way that the angle of incidence of the light beam is equal to $0 \pm 5^\circ$. The regular light transmittance shall be measured on the glazing, and for every point measured the number of divisions, n , shown on the indicating instrument, shall be read. The regular transmittance τ_r is equal to $n/100$.

6.11.3. Test pieces

6.11.3.1. Test pieces shall be either flat samples or finished products.

6.11.3.2. In the case of windscreens the test area shall be as defined in paragraph 7.1.3.4.

6.12. Optical distortion test

6.12.1. Apparatus

The apparatus shall comprise the following items, arranged as shown in Figure 6

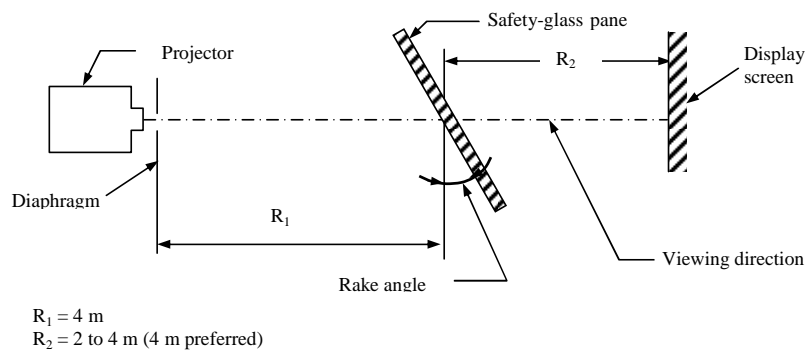

Figure 6: Arrangement of the apparatus for the optical distortion test

6.12.1.1. Projector with a high-intensity point light source. R_2

6.12.1.1.1. The projector shall have the following characteristics:

6.12.1.1.1.1. Focal length at least 90 mm.

6.12.1.1.1.2. Aperture 1/2.5.

6.12.1.1.1.3. 150 W quartz halogen lamp (if used without a filter).

6.12.1.1.1.4. 250 W quartz halogen lamp (if a green filter is used).

6.12.1.1.1.4.1. The projector is shown schematically in Figure 7. A diaphragm of 8 mm in diameter is positioned 10 mm from the front lens.

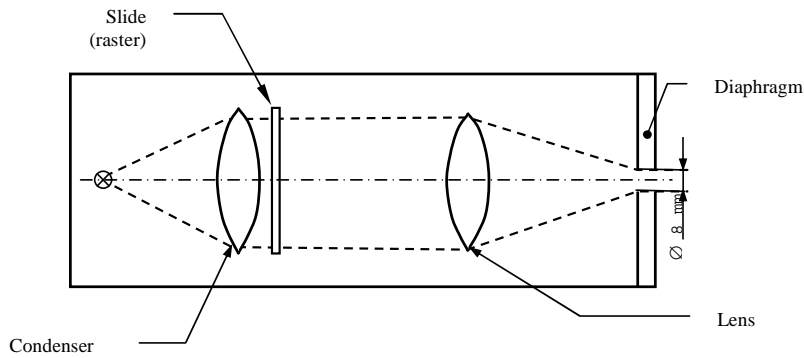

Figure 7: Optical arrangement of the projector

- 6.12.1.2. Slides (rasters) consisting, for example, of an array of bright circular shapes on a dark background (see Figure 8). The slides shall be of sufficiently high quality and contrast to enable measurement to be carried out with an error of less than 5 per cent. In the absence of the glazing to be examined, the dimensions of the circular shapes shall be such that when the circular shapes are projected they form an array of circles of diameter

$$\frac{R_1 + R_2}{R_1} \cdot \Delta x, \text{ where } \Delta x = 4 \text{ mm (Figures 6 and 9).}$$

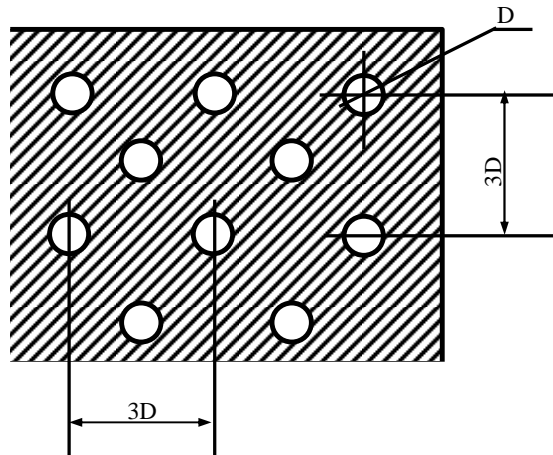

Figure 8: Enlarged section of the slide

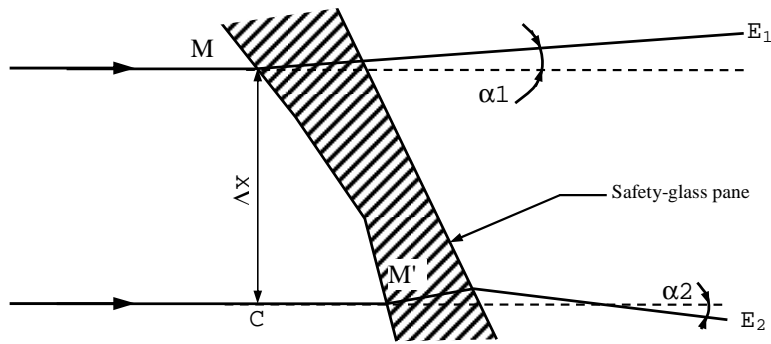

Figure 9: Diagrammatic representation of optical distortion

Notes:

$\Delta\alpha = \alpha_1 - \alpha_2$, i.e. the optical distortion in the direction M-M'.

$\Delta x = MC$, i.e. the distance between two straight lines parallel to the direction of vision and passing through the points M and M'.

- 6.12.1.3. Support stand, permitting vertical and horizontal scanning, rotation of the windscreen, and mounting of the windscreen at a full range of installation angles of inclination.
- 6.12.1.4. Checking template for measuring changes in dimensions. A suitable design is shown in Figure 10.

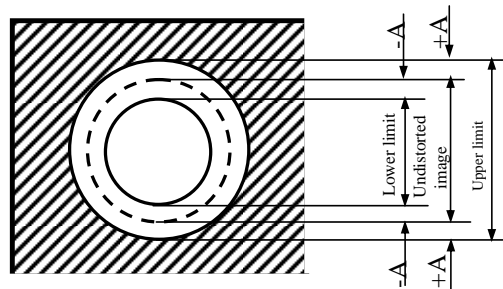

Figure 10: Design for a Suitable Checking Template

6.12.2. Procedure

6.12.2.1. General

- 6.12.2.1.1. Mount the windscreen on the support stand at the designed angle of inclination.
- 6.12.2.1.2. Project the test image through the area being examined.
- 6.12.2.1.3. Rotate the windscreen or move it either horizontally or vertically in order to examine the whole of the specified area.
- 6.12.2.1.4. The distance Δx shall be 4 mm.
- 6.12.2.1.5. The projection axis in the horizontal plane shall be maintained approximately normal to the trace of the windscreen in that plane.
- 6.12.2.2. Calculate the value of A (Figure 10) from the limit value $\Delta\alpha_L$ for the change in deviation and the value of R_2 , the distance from the windscreen to the display screen:

$$A = 0.145 \Delta\alpha_L \cdot R_2$$

The relationship between the change in diameter of the projected image Δd and the change in angular deviation $\Delta\alpha$ is given by

$$\Delta d = 0.29 \Delta\alpha \cdot R_2,$$

where:

- Δd is in millimetres;
- A is in millimetres;
- $\Delta\alpha_L$ is in minutes of arc;
- $\Delta\alpha$ is in minutes of arc;
- R_2 is in metres.

- 6.12.3. Expression of Results. Evaluate the optical distortion of the windscreen by measuring Δd at any point of the surface and in all directions in order to find Δd max.
- 6.12.4. Alternative Method. A strioscopic technique is permitted as an alternative to the projection techniques, provided that the accuracy of the measurements given in paragraph 6.12.2.2. is maintained.
- 6.12.5. Test pieces
- 6.12.5.1. The test pieces shall be windscreens.

6.13. Secondary image separation test

6.13.1. Target test

6.13.1.1. Apparatus

6.13.1.1.1. This method involves viewing an illuminated target through the windscreen. The target may be designed in such a way that the test can be carried out on a simple 'go-no go' basis.

6.13.1.1.2. The target shall be of one of the following types:

6.13.1.1.2.1. an illuminated 'ring' target whose outer diameter, D , subtends an angle of η minutes of arc at a point situated at x metres (Figure 11 (a)), or

6.13.1.1.2.2. an illuminated 'ring and spot' target whose dimensions are such that the distance, D , from a point on the edge of the spot to the nearest point on the inside of the circle subtends an angle of η minutes of arc at a point situated at x metres (Figure 11 (b)), where:

η is the limit value of secondary-image separation,

x is the distance from the safety-glass pane to the target (not less than 7 m),

D is given by the formula: $D = x \cdot \text{tg } \eta$

6.13.1.1.3. The illuminated target consists of a light box, 300 mm x 300 mm x 150 mm.

6.13.1.2. Procedure

6.13.1.2.1. Mount the safety-glass pane at the angle of inclination on a suitable stand in such a way that the observation is carried out in the horizontal plane passing through the centre of the target.

6.13.1.2.2. The light box shall be viewed, in a dark or semi-dark room, through each part of the area being examined, in order to detect the presence of any secondary image associated with the illuminated target.

6.13.1.2.3. Rotate the windscreen as necessary to ensure that the correct direction of view is maintained. A monocular may be used for viewing.

6.13.1.3. Expression of results. Determine whether:

6.13.1.3.1. When target (a) (Figure 11 (a)) is used, the primary and secondary images of the circle separate, i.e. whether the limit value of η is exceeded, or

6.13.1.3.2. When target (b) (Figure 11 (b)) is used, the secondary image of the spot shifts beyond the point of tangency with the inside edge of the circle, i.e. whether the limit value of η is exceeded.

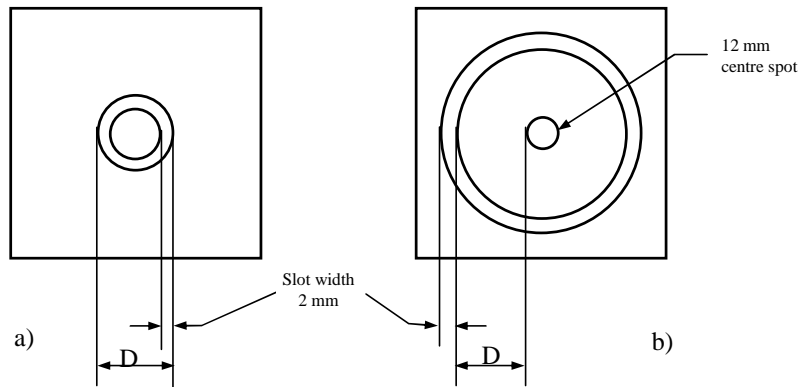

Figure 11: Dimensions of targets

6.13.2. Alternative collimation-telescope test

6.13.2.1. Apparatus

6.13.2.1.1. The apparatus comprises a collimator and a telescope and may be set up in accordance with Figure 12. However, any equivalent optical system may be used.

6.13.2.2. Procedure

6.13.2.2.1. The collimation telescope forms at infinity the image of a polar co-ordinate system with a bright point at its centre (Figure 13).

6.13.2.2.2. In the focal plane of the observation telescope, a small opaque spot with a diameter slightly larger than that of the projected bright point is placed on the optical axis, thus obscuring the bright point.

6.13.2.2.3. When a test piece which exhibits a secondary image is placed between the telescope and the collimator, a second, less bright point appears at a certain distance from the centre of the polar co-ordinate system. The secondary-image separation can be read out as the distance between the points seen through the observation telescope (Figure 13).

6.13.2.2.4. The distance between the dark spot and the bright point at the centre of the polar co-ordinate system represents the optical deviation.

6.13.2.3. Expression of Results. The windscreen shall first be examined by a simple scanning technique to establish the area giving the strongest secondary image. That area shall then be examined by the collimator-telescope system at the

appropriate angle of incidence. The maximum secondary-image separation shall be measured.

- 6.13.3. The direction of observation in the horizontal plane shall be maintained approximately normal to the trace of the windscreen in that plane.

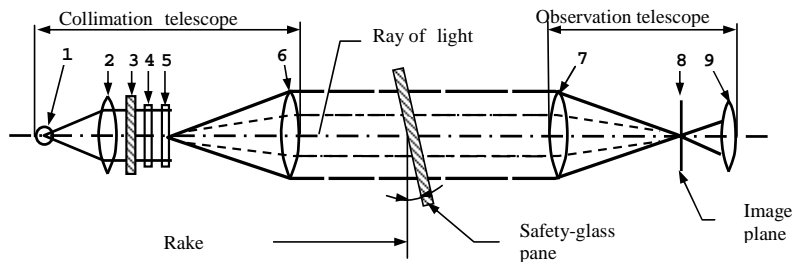

- (1) Lamp bulb
- (2) Condenser aperture > 8.6 mm
- (3) Ground-glass screen aperture > condenser aperture
- (4) Colour filter with central hole approximately 0.3 mm in diameter, diameter > 8.6 mm
- (5) Polar co-ordinate plate, diameter > 8.6 mm
- (6) Achromatic lens, $f \geq 86$ mm, aperture 10 mm
- (7) Achromatic lens, $f \geq 86$ mm, aperture 10 mm
- (8) Black spot, diameter approximately 0.3 mm
- (9) Achromatic lens, $f = 20$ mm, aperture < 10 mm.

Figure 12: Apparatus for collimation-telescope test

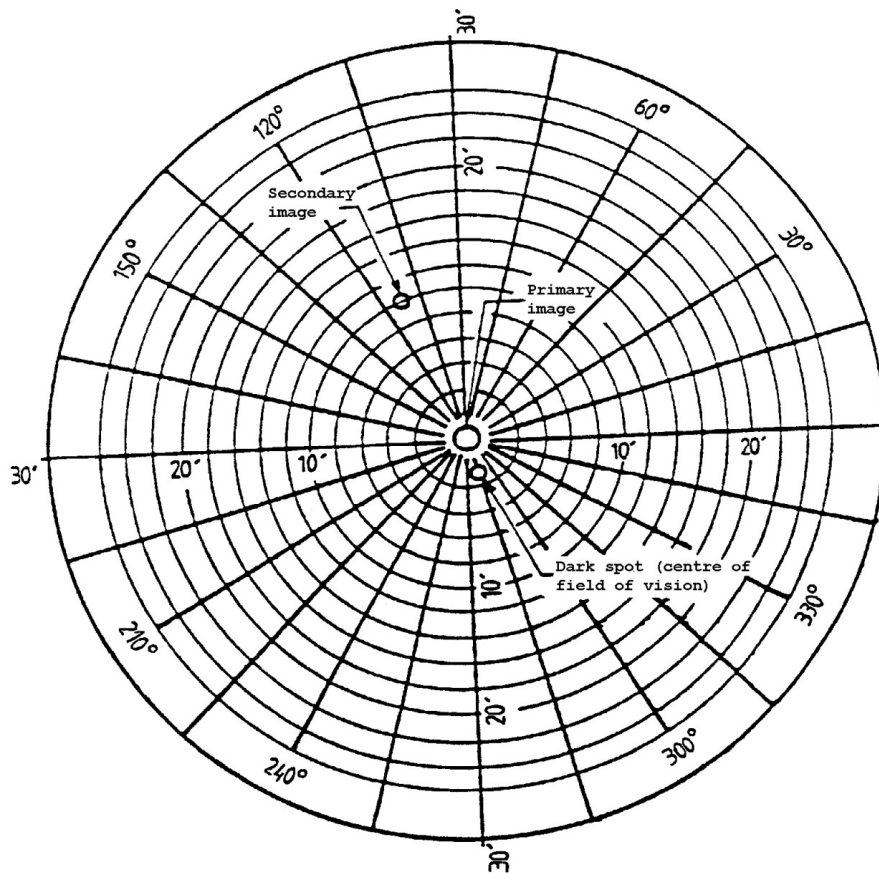

Figure 13: Example of observation by the collimation-telescope test method

6.13.4. Test pieces

6.13.4.1. The test pieces shall be windscreens.

6.14. Fire resistance test

6.14.1 Apparatus

6.14.1.1. Combustion chamber

6.14.1.1.1. The combustion chamber is illustrated by Figure 14, having the dimensions given in Figure 15.

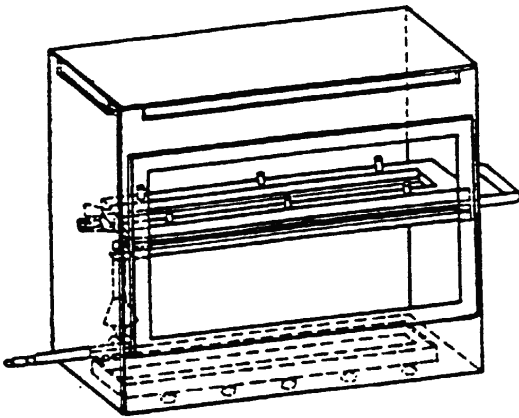

Figure 14: Example of Combustion Chamber with Sample Holder and Drip Pan

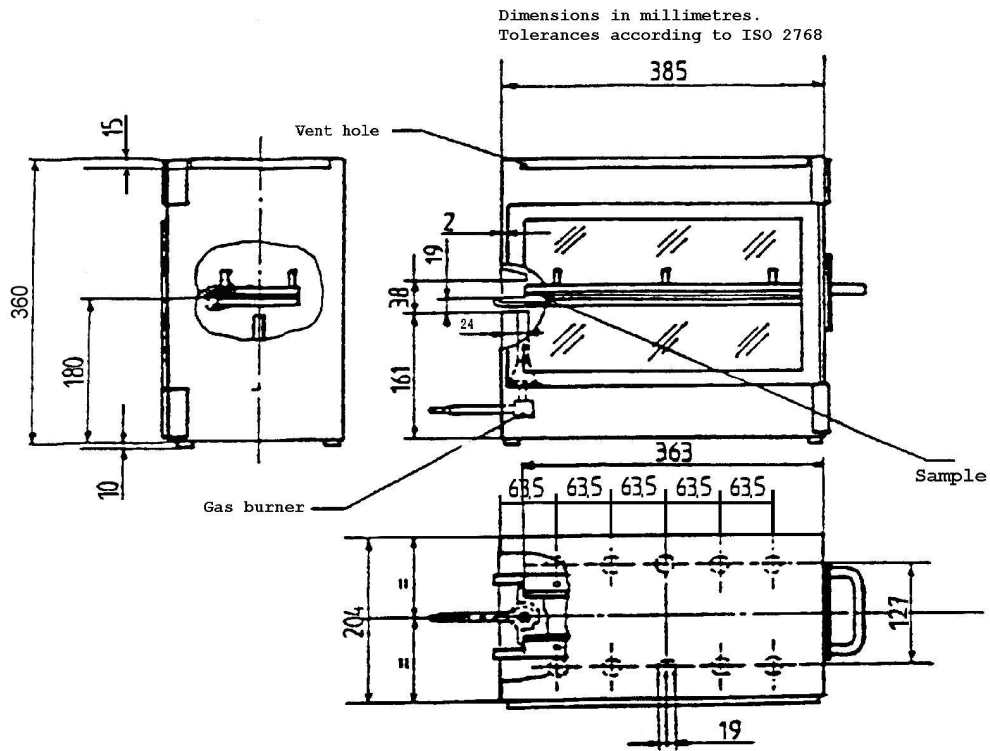

Figure 15: Example of Combustion Chamber

- 6.14.1.1.2. The combustion chamber is constructed of stainless steel.
- 6.14.1.1.3. The front of the chamber contains a flame-resistant observation window, which may cover the entire front and which can be constructed as an access panel.
- 6.14.1.1.4. The bottom of the chamber has vent holes, and the top has a vent slot all around.
- 6.14.1.1.5. The combustion chamber is placed on four feet, 10 mm high. The chamber may have a hole at one end for the introduction of the sample holder containing the sample; in the opposite end, a hole is provided for the gas-supply line. Melted material is caught in a pan (Figure 16) which is placed on the bottom of the chamber between vent holes without covering any vent hole area.

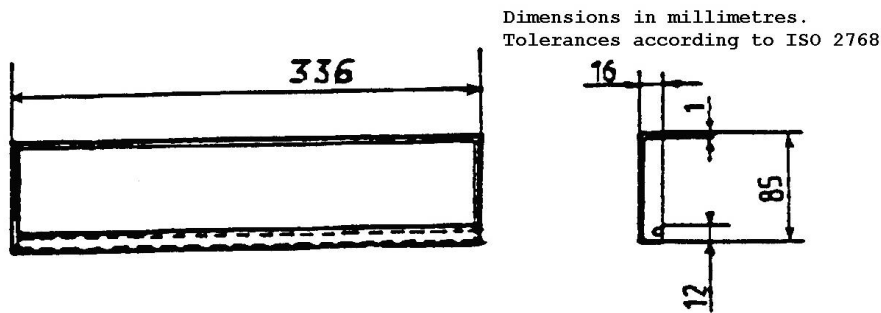

Figure 16: Typical drip pan

- 6.14.1.2. Sample holder
 - 6.14.1.2.1. The sample holder consists of two U-shaped metal plates or frames of corrosion-proof material. Dimensions are given in Figure 17.

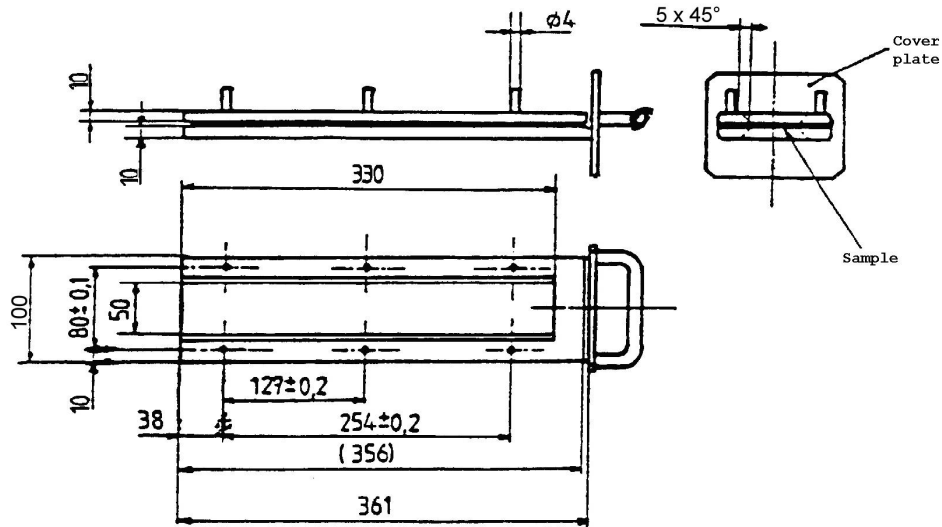

Figure 17: Example of sample holder

- 6.14.1.2.2. The lower plate is equipped with pins and the upper one with corresponding holes, in order to ensure a consistent holding of the sample. The pins also serve as measuring points at the beginning and end of the burning distance.
- 6.14.1.2.3. A support shall be provided in the form of heat-resistant wires 0.25 mm in diameter spanning the frame at 25 mm intervals over the bottom U-shaped frame (Figure 18).

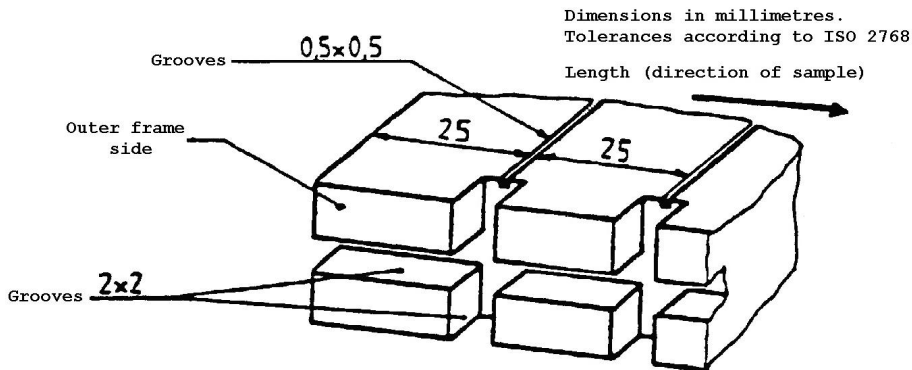

Figure 18: Example of section of lower U-frame design for wire support facility

- 6.14.1.2.4. The plane of the lower side of samples shall be 178 mm above the floor plate. The distance of the front edge of the sample holder from the end of the chamber shall be 22 mm; the distance of the longitudinal sides of the sample holder from the sides of the chamber shall be 50 mm (all inside dimensions). (Figures 14 and 15.)
- 6.14.1.3. Gas burner. The small ignition source is provided by a Bunsen burner having an inside diameter of 9.5 mm. It is so located in the test cabinet that the centre of its nozzle is 19 mm below the centre of the bottom edge of the open end of the sample (Figure 15).
- 6.14.1.4. Test gas. The gas supplied to the burner shall have a calorific value of about 38 MJ/m³ (for example natural gas).
- 6.14.1.5. Metal comb, at least 110 mm in length, with seven or eight smooth rounded teeth per 25 mm.
- 6.14.1.6. Stop-watch, accurate to 0.5 seconds.
- 6.14.1.7. Fume cupboard
- 6.14.1.7.1. The combustion chamber may be placed in a fume-cupboard assembly provided that the latter internal volume is at least 20 times, but not more than 110 times greater than the volume of the combustion chamber and provided that no single height, width, or length dimension of the fume cupboard is greater than 2.5 times either of the other two dimensions.
- 6.14.1.7.2. Before the test, the vertical velocity of the air through the fume cupboard shall be measured 100 mm forward of and to the rear of the ultimate site of the combustion chamber. It shall be between 0.10 and 0.30 m/s in order to avoid possible discomfort to the operator from combustion products. It is possible to use a fume cupboard with natural ventilation and an appropriate air velocity.
- 6.14.2. Procedure
- 6.14.2.1. Conditioning. The samples shall be conditioned for at least 24 hours, but not more than 7 days, at a temperature of 20 ± 5 °C and a relative humidity of 60 ± 20 per cent and shall be maintained under these conditions until immediately prior to testing.
- 6.14.2.2. Place samples with napped or tufted surfaces on a flat surface, and comb twice against the nap using the comb (paragraph 6.14.1.5.).
- 6.14.2.3. So place the sample in the sample holder (paragraph 6.14.1.2.1.) that the inner side faces downwards, towards the flame.
- 6.14.2.4. Adjust the gas flame to a height of 38 mm using the mark in the chamber, the air intake of the burner being closed. The flame shall burn for at least one minute, for stabilisation, before the first test is started.

- 6.14.2.5. Push the sample holder into the combustion chamber so that the end of the sample is exposed to the flame, and after 15 seconds cut off the gas flow.
- 6.14.2.6. Measurement of burning time starts at the moment when the foot of the flame passes the first measuring point. Observe the flame propagation on the side (upper or lower) whichever burns faster.
- 6.14.2.7. Measurement of burning time is completed when the flame has come to the last measuring point or when the flame is extinguished before reaching that point. If the flame does not reach the last measuring point, measure the burnt distance up to the point where the flame was extinguished. Burnt distance is the part of the sample destroyed, on the surface or inside, by burning.
- 6.14.2.8. If the sample does not ignite or does not continue burning after the burner has been extinguished, or the flame goes out before reaching the first measuring point, so that no burning time is measured, note in the test report that the burning rate is 0 mm/min.
- 6.14.2.9. When running a series of tests or performing repeat tests, make sure before starting a test that the temperature of the combustion chamber and sample holder does not exceed 30 ° C.

6.14.2.10. Calculation

The burning rate B, in millimetres per minute, is given by the formula $B = s/t \cdot 60$; where:
s is the burnt distance, in millimetres, t is the time in seconds, taken to burn the distance s.

6.14.3. Test pieces

6.14.3.1. Shape and dimensions

- 6.14.3.1.1. The shape and dimensions of samples are given in Figure 19. The thickness of the sample corresponds to the thickness of the product to be tested. It shall not be more than 13 mm. When sample-taking so permits, the sample shall have a constant section over its entire length.

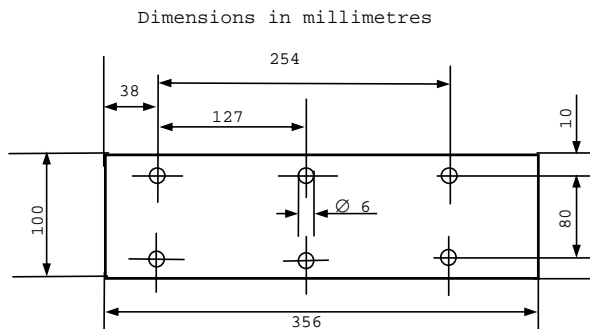

6.14.3.1.2. When the shape and dimensions of a product do not permit taking a sample of the given size, the following minimum dimensions shall be observed:

- (a) For samples having a width of 3 to 60 mm, the length shall be 356 mm. In this case the material is tested over the product width;
- (b) For samples having a width of 60 to 100 mm, the length shall be at least 138 mm. In this case the potential burning distance corresponds to the length of the sample, the measurement starting at the first measuring point;
- (c) Samples less than 60 mm wide and less than 356 mm long, and samples 60 to 100 mm wide and less than 138 mm long, cannot be tested according to the present method, nor can samples less than 3 mm wide.

6.14.3.2. Sampling

6.14.3.2.1. Five samples shall be taken from the material under test. In materials having burning rates differing according to the direction of the material (this being established by preliminary tests) the five samples shall be taken and be placed in the test apparatus in such a way that the highest burning rate will be measured.

6.14.3.2.2. When the material is supplied in set widths, a length of at least 500 mm covering the entire width shall be cut. From the piece so cut, the samples shall be taken at not less than 100 mm from the edge of the material and at points equidistant from each other.

6.14.3.2.3. Samples shall be taken in the same way from finished products when the shape of the product so permits. If the thickness of the product is over 13 mm it shall be reduced to 13 mm by a mechanical process applied to the side which does not face the passenger compartment.

6.14.3.2.4. Composite materials shall be tested as if they were homogeneous.

6.14.3.2.5. In the case of materials comprising superimposed layers of different composition which are not composite materials, all the layers of material included within a depth

of 13 mm from the surface facing towards the passenger compartment shall be tested individually

6.15. Test of resistance to chemicals

6.15.1. Chemicals used for the test

6.15.1.1. Non-abrasive soap solution: 1 per cent by mass of potassium oleate in deionized water;

6.15.1.2. Window-cleaning solution: an aqueous solution of isopropanol and dipropylene glycol monomethyl ether in concentration between 5 and 10 per cent by mass each and ammonium hydroxide in concentration between 1 and 5 per cent by mass;

6.15.1.3. Undiluted denatured alcohol: 1 part by volume methyl alcohol in 10 parts by volume ethyl alcohol;

Petrol or equivalent reference petrol: a mixture of 50 per cent by volume toluene, 30 per cent by volume 2,2,4-trimethylpentane, 15 per cent by volume 2,4,4-trimethyl-1-pentene and 5 per cent by volume ethyl alcohol;

N.B.: The composition of the petrol used shall be recorded in the test report.

6.15.1.5. Reference kerosene: a mixture of 50 per cent by volume n-octane and 50 per cent by volume n-decane.

6.15.2. Procedure

6.15.2.1. Immersion Test

6.15.2.1.1. Test pieces shall be tested with each of the chemicals specified in paragraph 6.15.1. above, using a new test piece for each test and each cleaning product.

6.15.2.1.2. Before each test, test pieces shall be cleaned according to the manufacturer's instruction, then conditioned for 48 hours at the conditions specified in paragraph 6.1. These conditions shall be maintained throughout the tests.

6.15.2.1.3. The test pieces shall be completely immersed in the test fluid and held for one minute, then removed and immediately wiped dry with a clean absorbent cotton cloth.

6.15.3. Test pieces

6.15.3.1. The test pieces shall be flat samples measuring 180 x 25 mm.

7. ANNEXES

7.1. Annex 7.1. Procedures for determining test areas on windscreens of Category 1-1 vehicles in relation to the "V" Points and Category 1-2 and 2 vehicles in relation to the "O" point.

7.1.1. Position of the "V" points

7.1.1.1. The position of the "V" points in relation to the "R" point as indicated by the X Y and Z co-ordinates in the three-dimensional reference system, are shown in Tables 1 and 2.

7.1.1.2. Table 1 gives the basic co-ordinates for a design seat-back angle of 25°. The positive direction of the co-ordinates is shown in this annex, Figure 3.

Table 1

"V" Point	A	b	c(d)
V ₁	68 mm	-5 mm	665 mm
V ₂	68 mm	-5 mm	589 mm

7.1.1.3. Correction for design seat-back angles other than 25 °

7.1.1.3.1. Table 2 shows the further corrections to be made to the X and Z co-ordinates of each "V" point when the design seat-back angle is not 25°. The positive direction of the co-ordinates is shown in this annex, Figure 3.

Table 2

Seat-back angle (in °)	Horizontal co-ordinates X	Vertical co-ordinates Z	Seat-back angle (in °)	Horizontal co-ordinates X	Vertical co-ordinates Z
5	- 186 mm	28 mm	23	- 18 mm	5 mm
6	- 177 mm	27 mm	24	- 9 mm	3 mm
7	- 167 mm	27 mm	25	0 mm	0 mm
8	- 157 mm	27 mm	26	9 mm	- 3 mm
9	- 147 mm	26 mm	27	17 mm	- 5 mm
10	- 137 mm	25 mm	28	26 mm	- 8 mm
11	- 128 mm	24 mm	29	34 mm	- 11 mm
12	- 118 mm	23 mm	30	43 mm	- 14 mm
13	- 109 mm	22 mm	31	51 mm	- 18 mm
14	- 99 mm	21 mm	32	59 mm	- 21 mm
15	- 90 mm	20 mm	33	67 mm	- 24 mm
16	- 81 mm	18 mm	34	76 mm	- 28 mm

Seat-back angle (in °)	Horizontal co-ordinates X	Vertical co-ordinates Z	Seat-back angle (in °)	Horizontal co-ordinates X	Vertical co-ordinates Z
17	- 72 mm	17 mm	35	84 mm	- 32 mm
18	- 62 mm	15 mm	36	92 mm	- 35 mm
19	- 53 mm	13 mm	37	100 mm	- 39 mm
20	- 44 mm	11 mm	38	108 mm	- 43 mm
21	- 35 mm	9 mm	39	115 mm	- 48 mm
22	- 26 mm	7 mm	40	123 mm	- 52 mm

7.1.2. Position of the "O" point

7.1.2.1. The eye-point "O" is the point located 625 mm above the R-point in the vertical plane parallel to the longitudinal median plane of the vehicle for which the windscreen is intended, passing through the axis of the steering wheel.

7.1.3. Test areas

7.1.3.1. The test areas shall be determined as follows:

7.1.3.1.1. For optical distortion and image separation measurement

In case of Category 1-1 vehicles according to paragraph 7.1.3.2.

In case of Category 1-2 and 2 vehicles according to paragraph 7.1.3.3.

7.1.3.2.1. For the measurement of the light transmittance in the transparent area of the windscreen according to paragraph 7.1.3.4.

7.1.3.2. Determination of two test areas for Category 1-1 vehicles using the "V" points

7.1.3.2.1. Test area A is the area on the outer surface of the windscreen bounded by the following four planes extending forward from the "V" points (see Figure 1):

- (a) A plane parallel to the Y axis passing through V_1 and inclined upwards at 3° from the X axis (plane 1);
- (b) A plane parallel to the Y axis passing through V_2 and inclined downwards at 1° from the X axis (plane 2);
- (c) A vertical plane passing through V_1 and V_2 and inclined at 13° to the left of the axis in the case of left-hand drive vehicles and to the right of the X axis in the case of right-hand drive vehicles (plane 3);
- (d) A vertical plane passing through V_1 and V_2 and inclined at 20° to the right of the X axis in the case of left-hand drive vehicles and to the left of the X axis in the case of right-hand drive vehicles (plane 4).

7.1.3.2.2. The "extended test area A" is Zone A, extended to the median plane of the vehicle, and in the corresponding part of the windscreen symmetrical to it about the

longitudinal median plane of the vehicle, and also in the reduced test area B according to paragraph 7.1.3.2.4. of this annex.

- 7.1.3.2.3. Test area B is the area of the outer surface of the windscreen bounded by the intersection of the following four planes (see Figure 2):
- (a) A plane inclined upward from the X axis at 7°, passing through V₁ and parallel to the Y axis (plane 5);
 - (b) A plane inclined downward from the X axis at 5°, passing through V₂ and parallel to the Y axis (plane 6);
 - (c) A vertical plane passing through V₁ and V₂ and forming an angle of 17° to the left of the X axis in the case of left-hand drive vehicles and to the right of the X axis in the case of right-hand drive vehicles (plane 7);
 - (d) A plane symmetrical with respect to the plane 7 in relation to the longitudinal median plane of the vehicle (plane 8).
- 7.1.3.2.4. The "reduced test area B" is test area B with the exclusion of the following areas 5/ (see Figures 2 and 3):
- 7.1.3.2.4.1. The test area A defined under paragraph 7.1.3.2.1., extended according to paragraph 7.1.3.2.2. of this annex;
- 7.1.3.2.4.2. At the discretion of the vehicle manufacturer, one of the two following paragraphs may apply:
- 7.1.3.2.4.2.1. Any opaque obscuration bounded downwards by plane 1 and laterally by plane 4 and its symmetrical in relation to the longitudinal median plane of the vehicle (plane 4');
- 7.1.3.2.4.2.2. Any opaque obscuration bounded downwards by plane 1, provided it is inscribed in an area 300 mm wide centred on the longitudinal median plane of the vehicle, and provided the opaque obscuration below the plane 5 trace is inscribed in an area limited laterally by the traces of planes passing by the limits of a 150 mm wide segment 6/ and parallel respectively to the traces of planes 4 and 4';
- 7.1.3.2.4.3. Any opaque obscuration bounded by the intersection of the outer surface of the windscreen:
- (a) With a plane inclined downwards from the X axis at 4°, passing through V₂, and parallel to the Y axis (plane 9);
 - (b) With plane 6;
 - (c) With planes 7 and 8 or the edge of the outer surface of the windscreen if the intersection of plane 6 with plane 7 (plane 6 with plane 8) does not cross the outer surface of the windscreen;

5/ But taking into account the fact that the datum points as defined under paragraph 7.1.3.2.5. shall be located in the transparent area.

6/ Measured on the outer surface of the windscreen and on the trace of plane 1.

- 7.1.3.2.4.4. Any opaque obscuration bounded by the intersection of the outer surface of the windscreen:
- (a) With a horizontal plane passing through V_1 (plane 10);
 - (b) With plane 3 7/;
 - (c) With plane 7 8/ or the edge of the outer surface of the windscreen if the intersection of plane 6 with plane 7 (plane 6 with plane 8) does not cross the outer surface of the windscreen;
 - (d) With plane 9;
- 7.1.3.2.4.5. Any opaque band situated within planes P3/P7 and P5/P10 respectively, that does not extend by more than 25 mm from the edge of the design glass outline.
- 7.1.3.2.4.6. An area within 25 mm from the edge of the outer surface of the windscreen or from any opaque obscuration. This area shall not impinge on the extended test area A.
- 7.1.3.2.5. Definition of the datum points (see Figure 3)
- The datum points are points situated at the intersection with the outer surface of the windscreen of lines radiating forward from the V points:
- 7.1.3.2.5.1. upper vertical datum point forward of V_1 and 7° above the horizontal (Pr1);
 - 7.1.3.2.5.2. lower vertical datum point forward of V_2 and 5° below the horizontal (Pr2);
 - 7.1.3.2.5.3. horizontal datum point forward of V_1 and 17° to the left (Pr3);
 - 7.1.3.2.5.4. three additional datum points symmetrical to the points defined under paragraphs 7.1.3.2.5.1. to 7.1.3.2.5.3. in relation to the longitudinal median plane of the vehicle (respectively Pr'1, Pr'2, Pr'3).

7/ For the other side of the windscreen, with a symmetrical plane with respect to plane 3 in relation to the longitudinal median plane of the vehicle.

8/ 7 for the other side of the windscreen, with plane 8.

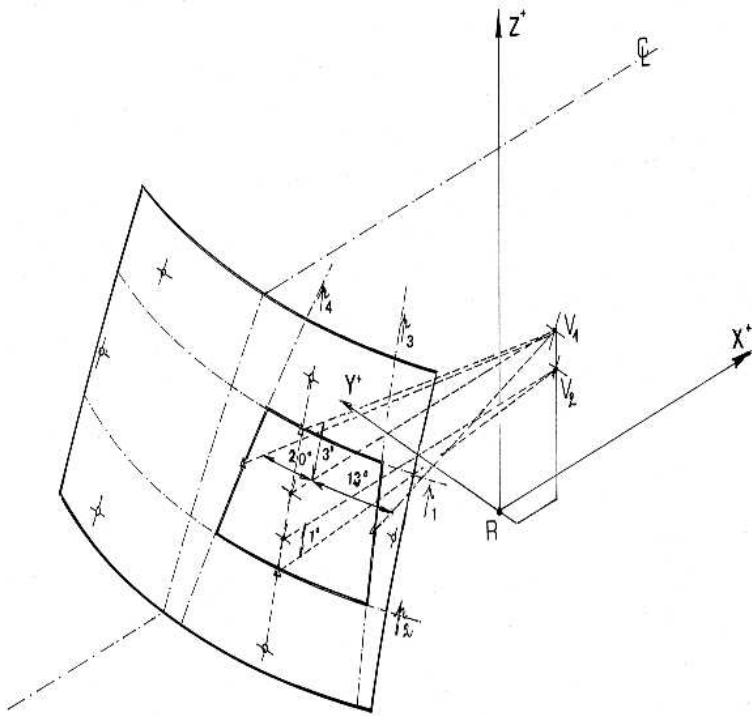

Figure 1: Test area "A" (example of a left-hand steering control vehicle)

<p>C_L: trace of the longitudinal median plane of the vehicle</p> <p>P_i: trace of the relevant plane (see text)</p>
--

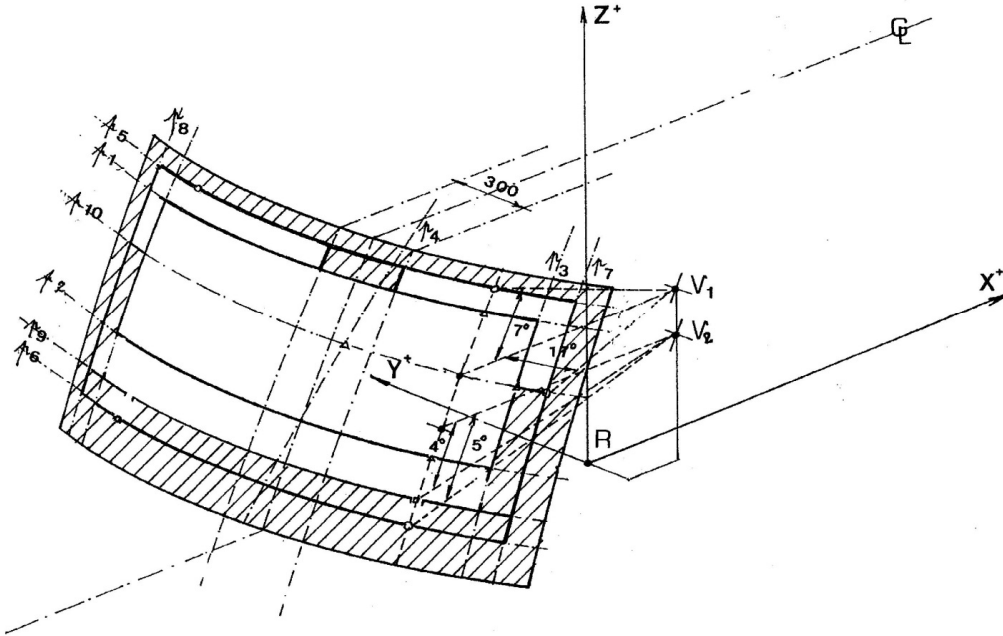

Figure 2(a): Reduced test area "B" (example of a left-hand steering control vehicle)

Upper obscuration area as defined in paragraph 7.1.3.2.4.2.2.

<p>C_L: trace of the longitudinal median plane of the vehicle P_i: trace of the relevant plane (see text)</p>

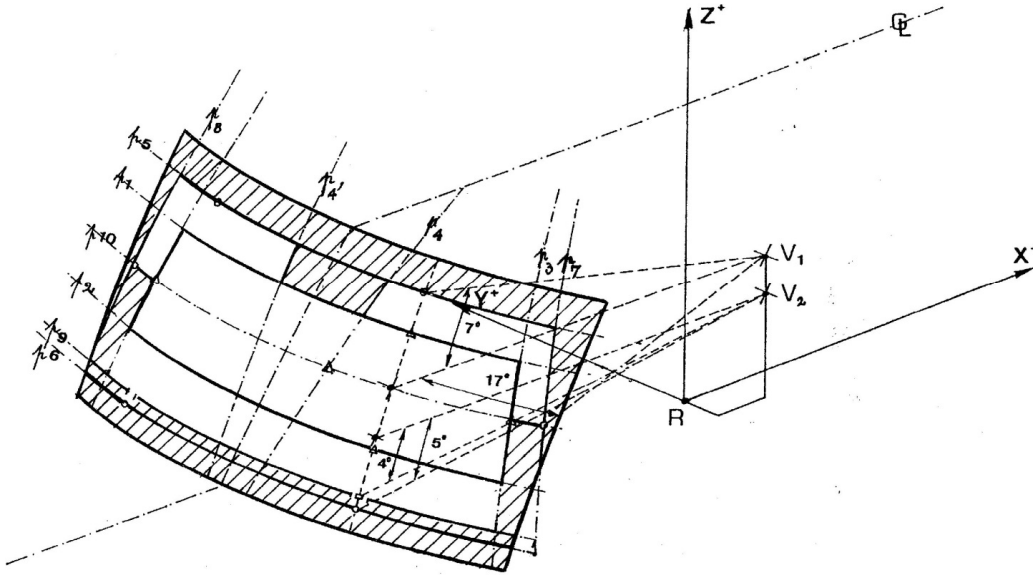

Figure 2(b): Reduced test area "B" (example of a left-hand steering control vehicle)

Upper obscuration area as defined in paragraph 7.1.3.2.4.2.1.

<p>C_L: trace of the longitudinal median plane of the vehicle</p> <p>P_i: trace of the relevant plane (see text)</p>
--

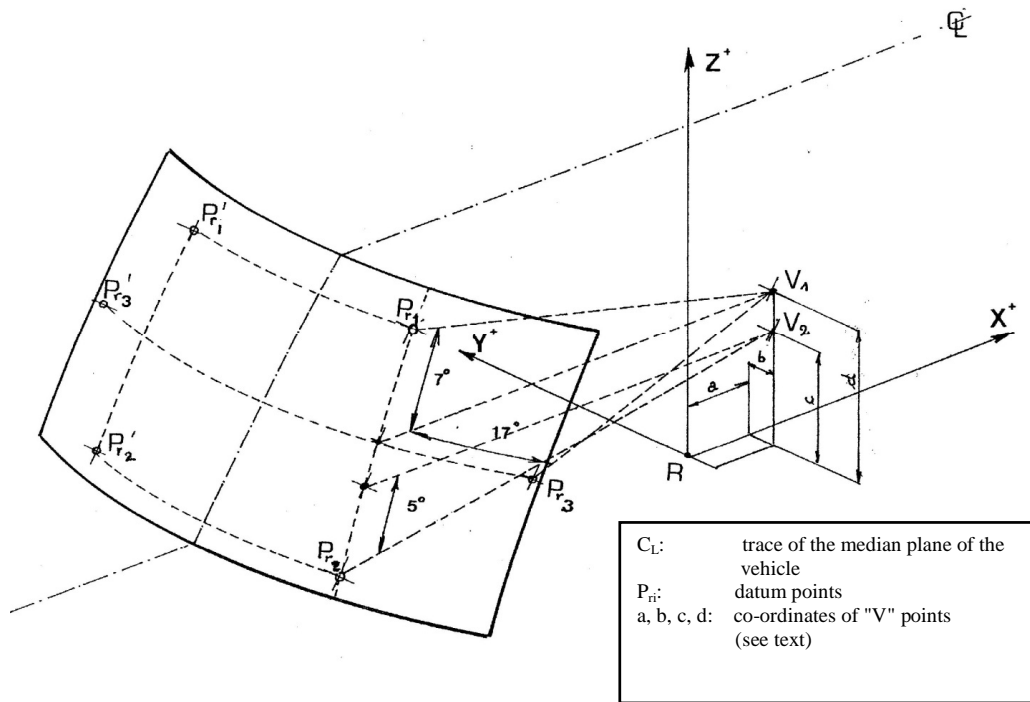

Figure 3: Determination of the datum points

(example of a left-hand steering control vehicle)

7.1.3.3. Determination of the Test Areas for Category 1-2 and 2 Vehicles using the "O" Point

7.1.3.3.1. The straight line OQ which is the horizontal straight line passing through the eye point "O" and perpendicular to the median longitudinal plane of the vehicle.

7.1.3.3.2. Zone I is the zone determined by the intersection of the windscreen with the four planes defined below:

P1 a vertical plane passing through O and forming an angle of 15° to the left of the median longitudinal plane of the vehicle;

P2 a vertical plane symmetrical to P1 about the median longitudinal plane of the vehicle.

If this is not possible (in the absence of a symmetrical median longitudinal plane, for instance) P2 shall be the plane symmetrical to P1 about the longitudinal plane of the vehicle passing through point O.

P3 a plane passing through a transverse horizontal line containing O and forming an angle of 10° above the horizontal plane;

P4 a plane passing through a transverse horizontal line containing O and forming an angle of 8° below the horizontal plane;

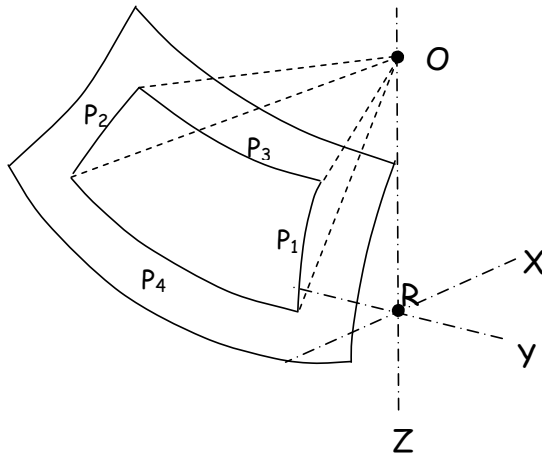

Figure 4: Determination of Zone I

7.1.3.4. Determination of the test area for light transmittance for all vehicle categories

The test area for light transmittance is the transparent area, excluding any opaque obscuration and any shade band. For practical reasons relating to the method of mounting and means of installation, it is accepted that a windscreen may incorporate an obscuration band which extends by not more than 25 mm from the edge of the design glass outline.

Additional opaque obscuration is also allowed in limited areas where it is intended that a sensing device, e.g. a rain-drop detector or rear view mirror, will be bonded to the inner side of the windscreen. The allowed areas where such devices may be applied are defined in paragraph 7.1.3.2.4. of this annex.

Annex 7.2. Measurement of the height of segment and position of the points of impact

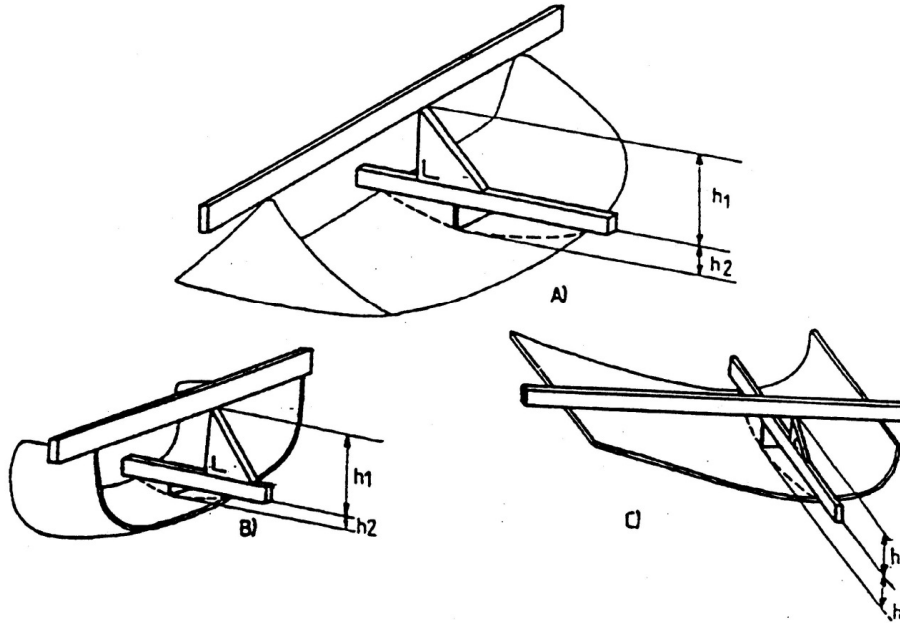
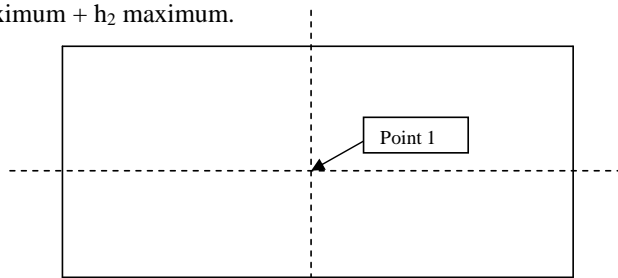

Figure 1: Determination of the height of segment "h"

In the case of glazing having a simple curvature, the height of segment will be equal to: h_1 maximum.

In the case of glazing having a double curvature, the height of segment will be equal to: h_1 maximum + h_2 maximum.



2(a) Flat glass pane

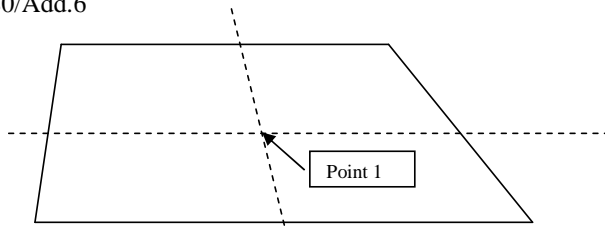

2(b) Flat glass pane

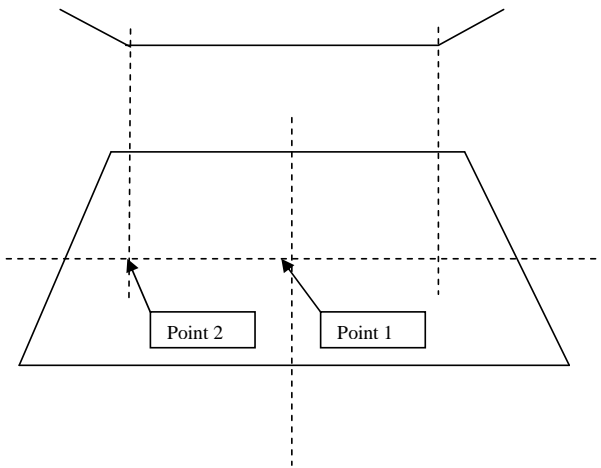

2(c) Curved glass pane

Figure 2: Prescribed points of impact for uniformly toughened glass panes

7.2 Procedures for determining test pieces for toughened glass

- o 7.2.1 Test pieces shall be determined as follows:
 - 7.2.1.1 Determination of test pieces which do not require opaque obscuration. Test pieces shall be 300 x 300 mm flat samples which are specially manufactured without any opaque obscuration area band, if the opaque obscuration band is not more than 25 mm inside the edge of the design glass outline.
 - 7.2.1.2 Determination of test pieces with opaque obscuration
Test pieces shall be 300 x 300 mm flat samples specially manufactured with opaque obscuration on the complete surface area if the opaque obscuration band is more than 25 mm inside the edge of the design glass outline.

Kommentar [m22]: New Section 7.2: Change Proposal by Industry (OICA/JAMA / ALLIANCE) presented in 4th meeting IWG PSG to split test specification in case of overhead glazing

7.2 Procedures for determining test pieces for toughened glass

- 7.2.1 Test pieces shall be determined as follows:
 - 7.2.1.1 Determination of test pieces which does not have opaque obscuration area
 - 7.2.1.1.1 Test pieces shall be 300 x 300 mm flat samples which is specially manufactured not to have any opaque obscuration area, if paragraphs 7.2.1.1.2. and 7.2.1.1.3. of this annex are met.
 - 7.2.1.1.2 For mounting the glass to vehicle, toughened glass shall incorporate opaque obscuration area no larger than 50% to the surface area of the finished product.
 - 7.2.1.1.3 If toughened glass is exposed to the inside of vehicle, the width of opaque obscuration area shall be no longer than 25mm from the edge of the design glass outline.
 - 7.2.1.2 Determination of opaque obscuration test pieces
 - 7.2.1.2.1 If a finished product does not comply with the requirements of paragraphs 7.2.1.1.2. and 7.2.1.1.3, test pieces shall be 300 x 300 mm flat samples, specially manufactured to have opaque obscuration area printed inside.

Kommentar [m23]: New Section 7.2: Change Proposal by KOREA presented in 4th meeting IWG PSG to split test specification in case of overhead glazing