

From: Daniel.J.Ridgeway@jci.com [mailto:Daniel.J.Ridgeway@jci.com]
Sent: Monday, June 18, 2012 11:14 AM
To: Smythe, Larry
Subject: Fw: GTR7 Email Sent By (smythel@nrd.nissan-usa.com).

Larry,

I had some folks at Johnson Controls review this document with the following comments. I doubt this has reached you in time, but wanted you to at least get some feedback from our side.

- The HR height requirement (5.5.1) makes no mention of a requirement for rear center position. The rear center position requirements listed in 4.4 start with HR width and skips height all together. The current ECE 17 requirement is 700 mm. Was this omitted intentionally, or will the 700 mm value still apply?
- Comment in the backset procedure states 10 N to be applied to the backset probe. This could add significant variation to HRs with thicker laminate. Is this expected to be part of the final procedure or just an investigation at this point?
- The measurement in Annex 5 does not take into account HRs with a non vertical front surface. It only measures the point horizontal from the center of the HRMD. If the HR has a significant forward or rearward angle the physical backset measurement using the probe could be different.
- I didn't see anything in the document about 3D cad measurement in the document? I agree the measurements are not repeatable. It appears the method for determining the head restraint height is changed. You find the point on the head restraint along the horizontal then measure the horizontal touching point along the torso angle - may be a slight change in the head restraint height values according to the STO.

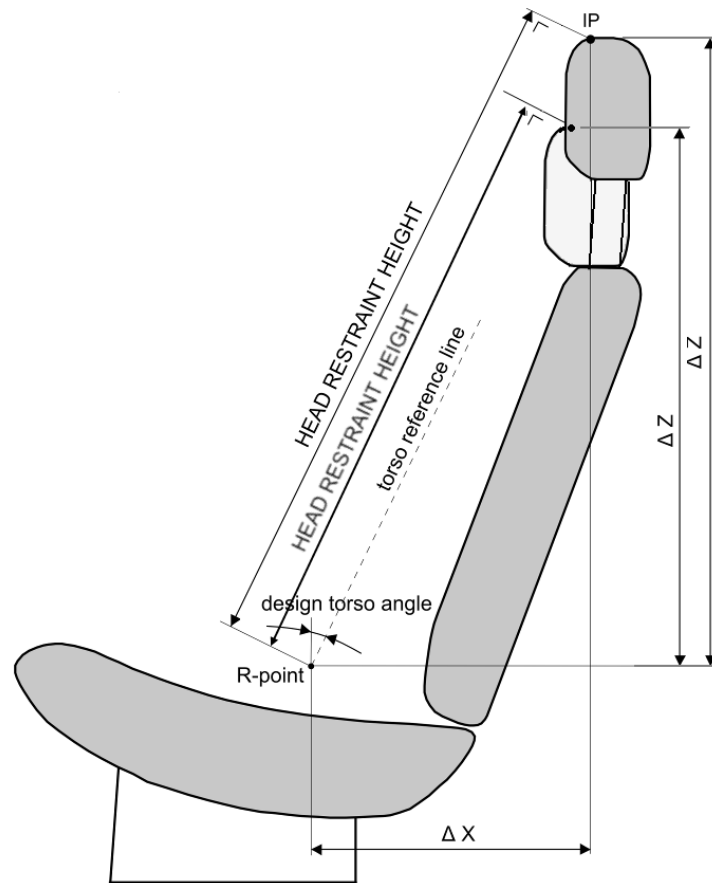

Figure 1-3

With Best Regards
Mit freundlichen Grüßen
宜しくお願ひ致します。

此致 敬礼!

건승하십시오

Saludos cordiales

Dan

Daniel Ridgeway
Engineering Manager
SMTE
Comfort & Human Factors Engineering
Automotive Experience
Tel.: 734-254-6208
Fax: 734-254-6277
Mobile: 734-478-5475
e-mail: Daniel.J.Ridgeway@jci.com
Internet: <http://www.johnsoncontrols.com/>

Johnson Controls, Inc
49200 Halyard Drive
Plymouth, MI 48170

----- Forwarded by Daniel J Ridgeway/ASG/Johnson_Controls on 06/18/2012 11:11 AM -----

From: Jeff Thompson/NA/Johnson_Controls
To: Daniel J Ridgeway/ASG/Johnson_Controls@Johnson_Controls, Patricia L White/ASG/Johnson_Controls@Johnson_Controls
Date: 06/06/2012 11:09 AM
Subject: Fw: GTR7 Email Sent By (smythel@nrd.nissan-usa.com).

FYI

Jeff Thompson
Purchasing
Johnson Controls - Automotive Experience
Office: 734.254.6278
Mobile: 248.703.3497

----- Forwarded by Jeff Thompson/NA/Johnson_Controls on 06/06/2012 11:08 AM -----

From: "StandardsWorks@sae.org" <StandardsWorks@sae.org>
To: <jeff.thompson@jci.com>
Date: 06/06/2012 09:41 AM
Subject: GTR7 Email Sent By (smythel@nrd.nissan-usa.com).

Dear HADD,

I just received that attached docs from the GTR7. Please review as we will discuss this at next week's meeting. Please pay special attention to manikin foot placement and HRMD measures.

Regards,

Larry