

EEVC/CEVE



European Experimental Vehicles Committee

EEVC Working Group 10 Report

Proposals for methods to evaluate pedestrian
protection for passenger cars

November 1994

Summary

In 1987 the European Experimental Vehicles Committee has set up Working Group 10 with the task to improve an existing proposal for an EC Directive with respect to pedestrian protection and to coordinate the necessary research.

This report gives a general description and background information of the test methods developed by EEVC WG10 for assessing the protection afforded to pedestrians by the fronts of cars in an accident. The test methods are based on sub-system tests, essentially to the bumper, bonnet leading edge and bonnet top surface.

The legform impactor used in the bumper tests, consists of two foam covered rigid segments representing the lower leg (tibia and foot) and upper leg (femur) of an adult, connected by a simulated knee joint that will rotate and translate laterally. The impact velocity of the legform impactor when striking the bumper in 'free flight' should be 40 km/h. The proposed acceptance levels for the three bumper tests are: 15 degrees of lateral knee bending rotation, 6 mm of lateral knee shearing displacement and 150 g lateral acceleration at the top of the tibia.

The upper legform impactor used in the bonnet leading edge tests, represents an adult upper leg. The impact mass, - velocity and - angle of the upper legform in the guided impact are dependent on the general shape of the vehicle front. The proposed acceptance levels for the three bonnet leading edge tests are: a total force of 4kN and a bending moment of 220 Nm.

An adult as well as a child headform impactor is used in the bonnet top tests, on the rearward and forward section of the bonnet respectively. The impact velocity of both headforms when striking the bonnet in 'free flight' should be 40 km/h. The proposed acceptance level for the nine bonnet top tests using the child headform impactor and for the nine bonnet top tests using the adult headform impactor is: the Head Performance Criterion calculated from the resultant acceleration time histories shall not exceed 1000.

The complete text of the test methods is included as Appendix.

The headform and upper legform impactors are now available. Prototype legform impactors have been available for some time and it is expected that a final version could be available in the Spring of 1995. The final static and dynamic certification requirements of this impactor could then be defined.

Several test programmes to current cars have shown that it is technically possible to fulfil the requirements proposed in the EEVC test method with new car designs. Nevertheless a phased-in introduction of the test requirements seems necessary, especially with respect to the 18 tests to the bonnet top.

It is also suggested to extend the proposed Directive to cover not only manufacturer mounted crash-bars, but also crash-bars (or bull-bars) fitted as after-market accessories, since several test programmes have shown how pedestrian unfriendly these (steel) bars are.

Contents	<i>page</i>
1 INTRODUCTION	4
2 WORK PROGRAMME	5
3 SUB-SYSTEM TEST METHODS	7
3.1 <u>Introduction</u>	
3.2 <u>Test area</u>	
3.2.1 Definitions	
3.2.2 Impact location	
3.3 <u>Test apparatus</u>	
3.3.1 Legform impactor	
3.3.2 Upper legform impactor	
3.3.3 Headform impactor	
3.4 <u>Impact conditions</u>	
3.4.1 Vehicle position	
3.4.2 Propulsion system	
3.4.3 Legform to bumper test	
3.4.4 Upper legform to bonnet leading edge test	
3.4.5 Headform to bonnet top test	
3.5 <u>Requirements</u>	
3.5.1 Legform to bumper test	
3.5.2 Upper legform to bonnet leading edge test	
3.5.3 Headform to bonnet top test	
3.5.4 Phasing of requirements	
4 EVALUATION OF TEST METHODS	16
4.1 <u>Introduction</u>	
4.2 <u>Legform to bumper test</u>	
4.3 <u>Upper legform to bonnet leading edge test</u>	
4.4 <u>Headform to bonnet top test</u>	
4.5 <u>Bull-bars</u>	
4.6 <u>Current vehicles</u>	
4.7 <u>Conclusions</u>	
5 COST BENEFIT STUDIES	20
6 CONCLUSIONS	21
REFERENCES	22
APPENDIX I - <u>Members/attenders of EEVC WG10 in 1991-1994</u>	26
APPENDIX II - <u>Proposal for test methods</u>	27

1 INTRODUCTION

In most European countries, unprotected road users like pedestrians account for a significant proportion of the road accident casualties. This was recognized by the European Experimental Vehicles Committee and several studies in this field were performed by Working Groups of EEVC [1,2,3]. Based on this research various recommendations for the front structure design of passenger cars were developed. Moreover, test methods and regulations have been proposed to assess pedestrian protection.

In the Spring of 1987 one of these proposals was discussed by the EEC ad-hoc working group 'Erga Safety' [4]. It was concluded that the basis of the proposal was promising however, additional research was needed to fill up some gaps. The European Experimental Vehicles Committee was asked to coordinate this research and at the end of 1987 EEVC Working Group 10 was set up.

The mandate of this group was 'to determine test methods and acceptance levels for assessing the protection afforded to pedestrians by the fronts of cars in an accident. The test methods should be based on sub-system tests, essentially to the bumper, bonnet leading edge and bonnet top surface. The bumper test should include the air dam; the bonnet leading edge test should include the headlight surround and the leading edge of the wings; the test to the bonnet top should include the scuttle, the lower edge of the windscreen frame and the top of the wings. Test methods should be considered that evaluate the performance of each part of the vehicle structure with respect to both child and adult pedestrians, at car to pedestrian impact speeds of 40 km/h. The different impact characteristics associated with changes in the general shape of the car front should be allowed for by variations in the test conditions (e.g. impact mass and velocity, direction of impact)'.

This report gives a general description and background information of the test methods proposed by EEVC WG10. Appendix II contains the complete text of the proposed test methods.

The work programme and time schedule of WG10 are presented in Chapter 2. The sub-system test methods are described in Chapter 3 and the evaluation of these methods in Chapter 4. Some remarks with respect to cost benefit studies associated with this topic are included in Chapter 5 and the conclusions of this report are summarized in Chapter 6.

2 WORK PROGRAMME

EEVC WG10 started its activities in January 1988. Both industry and research institutes were represented in the working group. A programme was set-up intended to develop the required test methods as described by the mandate.

The studies necessary to develop test methods were already presented in a *first* report of EEVC WG10, published in 1989 [5]. These development studies include full scale dummy tests, cadaver tests, accident reconstructions, analysis of accident data and computer simulations. Furthermore the developed test proposals should be tested against representative cars of current designs to determine the feasibility of the proposals. The compatibility with existing regulations, other safety features and basic operational requirements for cars should be assessed. Figure 1 shows the work programme.

These studies were performed in 1989/1990 by a European consortium acting under contract to the European Commission and under the auspices of EEVC Working Group 10. The consortium consisted of BAST, INRETS, LPB/APR, TNO and TRL. The studies were completed in June 1991 and were summarized individually in technical reports [6-11]. The summary report [12] includes an Annex called "Frontal surfaces in the event of impact with a vulnerable road user - proposal for test methods". Based on this document, EEC/DGIII has drafted an extension to the existing Council Directive 74/483/EEC ("external projections") for inclusion of the EEVC sub-system test methods for pedestrian safety [13]. This work was also summarized in a *second* EEVC WG10 report, published in 1991 [14].

The EEVC Main Committee decided to extend the mandate of WG10 in order '*to consider what work would be necessary to support the results obtained from the EC study and to finalize the work programme*'. WG10 restarted at the end of 1991 and since then the proposed test methods, including sub-system impactors, have been evaluated thoroughly. Changes and improvements were included in the working document "Frontal surfaces in the event of impact with a vulnerable road user - proposal for test methods". The members and organisations involved in the WG10 activities during the period 1991/1994 are presented in Appendix I.

This *third* report of EEVC WG10 will focus especially on the changes and improvements with respect to the previous version of the proposed test methods, as described in [12] and [14]. Also general background information will be given and choices that were made will be explained.

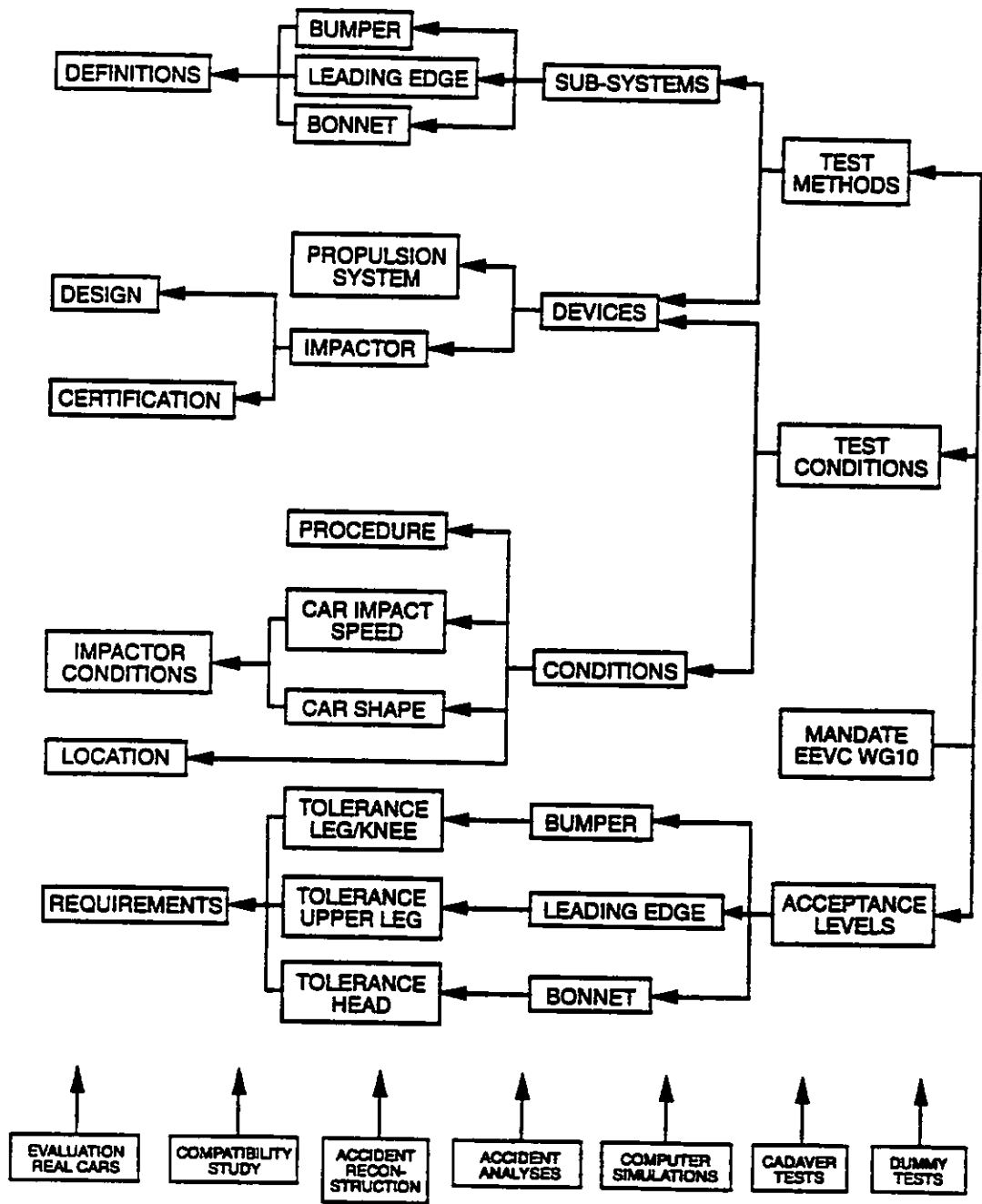

Figure 1. Mandate and work of EEVC WG10.

3 SUB-SYSTEM TEST METHODS

3.1 Introduction

In this chapter changes and improvements with respect to the previous version of the proposed test methods, as described in [12] and [14], will be presented. Also general background information will be given and choices that were made will be explained. Appendix II contains the complete text of the proposed test methods.

The test area's on the vehicle front are described in §3.2. The sub-system impactors, the test conditions and the test requirements are presented in §3.3, §3.4 and §3.5, respectively.

3.2 Test area

3.2.1 Definitions

Three sub-system tests are prescribed; legform to bumper, upper legform to bonnet leading edge and headform to bonnet top. The outer car structure representing these test areas is described in the test method¹. Attachments to these structures, for instance bull-bars and license plates, are also subject of these definitions and should be tested as such.

The bonnet top is divided in two areas; a forward area for a child headform impact and a rearward area (i.e. close to the windscreen) for an adult headform impact. Wrap around distances of 1000-1500mm and 1500-2100mm are defined for the boundaries of these two bonnet top test areas². The windscreen and A-pillars were not part of the mandate of WG10 and therefore not included as test area (the lower windscreen frame however is included) .

The width of each test area is divided in 3 equal parts; a left and right outer part and a middle part. The side of the test area's is also defined by means of the 'corners' of the bumper and the leading-edge, and the 'side' of the bonnet top.

For vehicles with a special shape, exclusions are included in the test methods. For instance no headform test should be performed if the lower windscreen frame is located forward of the 1000mm wrap around distance. No upper legform test needs to be performed if the determined kinetic energy of impact is 200 J or less, which can occur if the bonnet leading edge is located low and the bumper protrusion (i.e. bumper lead) is relatively large³. If the bumper is located high and close to the bonnet leading edge, an upper legform to bumper test rather than to the bonnet leading edge is possible⁴.

¹ Appendix II: Annex I; §2.2, §2.3 and §2.4.

² Appendix II: Annex I; §2.4.

³ Appendix II: Annex II; §5.3 and Figure 2.7.

⁴ Appendix II: Annex I; §2.3.1.

3.2.2 Impact location

A minimum of three legform to bumper tests should be performed, one on each of the three bumper parts. A minimum of three upper legform to bonnet leading edge tests should be performed, one on each of the three bonnet leading edge parts. A minimum of nine tests should be performed with the child headform impactor, three tests each on the three forward bonnet top parts. A minimum of nine tests should be performed with the adult headform impactor, three tests each on the three rearward bonnet top parts. Table 1 summarizes the minimum number of tests.

Table 1. Minimum number of required tests (see also text below table).

TEST AREA	left outer part	middle part	right outer part	total
bumper	1	1	1	3
leading edge	1	1	1	3
bonnet top - child	3	3	3	9
bonnet top - adult	3	3	3	9
total	8	8	8	24

The impact location should be on a 'position most likely to cause injury'⁵ in order to assess the injury risk for pedestrians. This position should be specified by the authorities after examining the vehicle and drawings supplied⁶.

The tests should be performed on different types of the vehicle structure, which means that it is not necessary to perform a test on a similar (read: symmetrical) construction in another part of the test area, even though this would be a 'high-injury-risk' location (e.g. bumper attachment in left and in right outer part of bumper test area).

Furthermore, the distance between different tests in one test area should be equal or larger than the diameter of the impactor used. This means for instance that the distance between the impact location of the test on the left outer part of the bumper and the impact location of the test on the middle part of the bumper should be at least 130 mm (i.e. diameter of legform impactor). Another example: the distance between the impact locations of the three impacts on the middle part of the bonnet top child area should be at least 130 mm (i.e. diameter of child headform impactor). The bonnet top is divided in two separate test area's, which means that the distance between an adult and child impact location can be less than this 130 mm (or 165 mm which is the diameter of the adult headform impactor).

⁵ Appendix II: Annex II; §4.2, §5.2 and §6.2.

⁶ Appendix II: Annex I; §3.3.

The distance between the impact location and the side of the vehicle should be equal to or more than the half diameter of the impactor used, to avoid a glance-off impact. For tests to the windscreen lower frame, contact of the headform impactor with the glass is not allowed before impacting the vehicle structure⁷.

The constraints indicated above could lead to fewer impacts than described in Table 1, for instance if the adult bonnet top area is very small.

3.3 Test apparatus

3.3.1 Legform impactor

The impactor that has been developed by INRETS for the bumper sub-systems test was chosen to represent an adult leg being impacted from the side. Accident studies have shown that in accidents at speeds up to 40 km/h, adults and particularly the aged, seem to be more at risk than children to leg injury that may result in permanent disability [14]. The legform impactor consists of two foam covered rigid segments representing the lower leg (tibia and foot) and upper leg (femur) of an adult, connected by a simulated knee joint that will rotate and translate laterally⁸. This lateral bending and shearing of the knee joint is resisted by deformable elements, which are replaced after each test.

Since the extension of the WG10 mandate, a lot of effort has been spent in the evaluation and improvement of the legform impactor [15]. The dimensions, masses and moment of inertia specifications have been improved and are based now on measurements from Robbins for a 50th percentile male [16]. A flesh-simulating foam has been selected ('Confor-foam') and in order to improve repeatability a cylindrical shape has been defined for this foam. The instrumentation has been improved; the angles between upper and lower leg are measured directly now, rather than by a non-linear cam mechanism. The knee protection criteria, which are bending angle and shearing displacement, are calculated from these measured angles. A calculation method has been defined by WG10.

A lot of effort has been spent in the optimization of the characteristics of the deformable elements to control the lateral bending and shearing motion of the knee joint. The quasi-static characteristics of the knee joint are presented in Figure 3.1 and 3.2 of Annex III in Appendix II. The elements were either too weak in bending or too stiff in shearing, or they deformed non-symmetrically around the knee axis, which makes the separation between bending and shearing difficult. Recently results of cadaver tests became available showing bending moments of 120-140Nm and associated bending angles of 9-11⁰, at the time of injury occurrence [17]. This bending stiffness seems much lower than the corridor presented in Figure 3.1 of Annex III⁹.

⁷ Appendix II: Annex II; §6.4.2.2.

⁸ Appendix II: Annex II; Figure 2.1.

⁹ The forces shown in Figure 3.1 of Annex III should be multiplied with 2m (see Figure 3.3) to obtain the applied bending moment.

However, these cadaver tests were performed at impact speeds of 16-20 km/h and due to the visco-elastic properties of the knee ligaments it can be anticipated that the lateral bending stiffness increases strongly with increasing impact speed [18]. Moreover, the absence of muscle force in the cadavers will lead to a lower bending stiffness than can be expected from human beings. Volunteers tests [19, 20] indicated a quasi-static lateral knee bending stiffness of 115-170Nm (without injury or discomfort).

The shear characteristic of the knee joint is a 'window' around the injury tolerance level of 4kN force and 6mm displacement¹⁰. WG10 considered also an alternative TRL knee design, in which the shearing is controlled by a leaf spring. The specifications of the legform¹¹ are also fulfilled by this second design. Evaluation and comparison of both designs should guide a final choice.

3.3.2 Upper legform impactor

Full-scale tests have shown that in a pedestrian accident the leading edge of the bonnet most frequently strikes the femur and pelvis of adults and the pelvis, abdomen or femur of children. Reports from European accident studies have shown that for accidents at speeds up to 40 km/h pelvic/femur fractures of AIS 3+ were more frequently to adults than to children. Child abdominal injury of AIS 3+ was rarely seen at speeds of 40 km/h or less [14]. As a consequence the impactor that has been developed by TRL for this sub-systems test represents a segment of an adult femur. The impactor consists of a foam covered tube mounted at either end through load cells to a support frame, which is in turn mounted through a torque limiting joint to a propulsion system¹². Supplementary weights can be attached to the support frame (i.e. rear member) to meet the impact conditions of the car under test. Strain gauges are attached to the impactor tube to measure bending moments.

Since the extension of the WG10 mandate, small improvements have been included in the upper legform design. The strain gauges are covered to protect them against damage. The material of the torque limiting joint has been changed since the use of asbestos is no longer allowed. A test programme has been performed to evaluate the temperature/time influence on the characteristics of the flesh simulating foam and to evaluate the durability of the foam [21]. It was concluded that the influence of the temperature is limited within the prescribed range for testing¹³. Furthermore, it was concluded that the flesh deteriorates slightly and becomes slightly softer with repeated testing, increasing the measured forces and bending moments. Therefore it is recommended to use new flesh before each regulatory test.

¹⁰ Appendix II: Annex III; Figure 3.2.

¹¹ Appendix II; Annex II; §4.4.1.

¹² Appendix II; Annex II; Figure 2.3.

¹³ Appendix II: Annex II; §4.4.2.1, §5.4.2.1 and §6.4.2.1.

A static calibration procedure has been developed to assess the sensitivity of the strain gauges. The dynamic certification procedure has been improved to obtain a more representative impact speed and impactor responses¹⁴.

3.3.3 Headform impactor

Accident data have shown that the head is the body region most frequently suffering from life threatening injuries in both child and adult pedestrian accidents [14]. As a consequence of these findings two assessments are included in this sub-systems test. One is based on an impactor representing a child headform to evaluate the forward section of the bonnet and wings and the second is based on an adult headform to assess the rear of the bonnet, wings and the scuttle.

Both of the headforms developed by BASt are of spherical shape and made of a semi-rigid material, covered by a rubber skin¹⁵. The adult impactor weighs 4.8 kg and the child impactor weighs 2.5 kg.

Since the extension of the WG10 mandate, small changes were included in the design of both headforms. The centre of gravity of the headform and the accelerometer are now located more accurately in the centre of the sphere. Furthermore the (end of the) skin is connected to the sphere to avoid rotation of the sphere inside the skin during an impact. A test programme has been performed to evaluate the influence of temperature and humidity on the impact responses of the skin [22]. It was concluded that the temperature, within the prescribed range, has no influence on the headform responses. A 5-10% increase in headform acceleration could be seen when the skin was soaked for 4 hours in water. It was recommended to store the skin in a humidity-controlled room.

The dynamic certification procedure has been improved, no different headform mass is required any more in the certification test. Moreover, the skin is certified now at several locations on the circumference¹⁶.

3.4 Impact conditions

3.4.1 Vehicle position

The vehicle or sub-system of the vehicle should be positioned such that it represents an impact between the vehicle, loaded with two occupants, and a pedestrian at an impact speed of 40 km/h. Brake diving is not simulated, because the car may not be braking at impact and many modern suspension systems are designed to reduce or eliminate brake dive. The suspension should be set for a driving speed of 40 km/h in normal running conditions, specified by the manufacturer, especially for vehicles with an active suspension or a device for automatic levelling¹⁷.

¹⁴ Appendix II; Annex III; §3.

¹⁵ Appendix II; Annex II; Figure 2.8 and 2.9.

¹⁶ Appendix II; Annex III; §4.

¹⁷ Appendix II; Annex I; §2.1.2.

In the legform to bumper test the vehicle or sub-system may be raised to avoid contact of the legform with the ground¹⁸.

Computer simulations showed that foot to ground friction appears to have only a minor influence on the loads generated in the leg during an impact. This shows that foot to ground friction forces may be omitted from a bumper sub-system test [14].

If the propulsion system used can not achieve the required impact angles necessary for the upper legform to bonnet leading edge test or for the headform to bonnet top test, the rear end of the vehicle may be raised to obtain the correct impact angle. However, this should not influence the performance of the vehicle (for instance by translation or rotation of the engine, creating additional space between engine and bonnet)¹⁹.

It is possible that the vehicle to be assessed incorporates special devices designed to protect vulnerable road users, for instance a bonnet top which is lifted when the leading edge is impacted by the pedestrian. These (dynamic) systems should be active during the appropriate test²⁰. If they are activated in real accidents by a mechanism outside the considered test area (e.g. bonnet lifting is activated by sensor in bumper), they should be activated correctly during or before the test by an external trigger or manually. It is the responsibility of the applicant for approval to show that the device is activated (fast enough) in a real accident.

3.4.2 Propulsion system

The type of propulsion system is not prescribed, however free flight impacts at 40 km/h with masses between 2.5 kg and 13.5 kg should be possible. The upper legform impactor should be mounted to the propulsion system by a torque limiting joint, to prevent damage to the system, and should be guided throughout the impact. This test requires impacts at 20 to 40 km/h at effective impactor masses (including guidance components) of 9.5 to 17.7 kg.

3.4.3 Legform to bumper test

The impact velocity of the 13.4 kg legform impactor when striking the bumper in 'free flight' is equal to the vehicle/pedestrian impact speed (40 km/h or 11.1 m/s). The impact direction is parallel to the longitudinal vehicle axis, with the legform impactor vertical. Small tolerances to these directions are allowed.

The impact position in the 'horizontal' direction is already described in §3.2. The impact position in the 'vertical' direction is prescribed by the dimensions of the legform impactor and by the bumper height; the bottom of the impactor is at ground level at the time of first contact with the bumper²¹.

¹⁸ Appendix II: Annex II; Figure 2.2.

¹⁹ Appendix II: Annex II; §2.1.2 and §2.2.3.

²⁰ Appendix II: Annex II; §2.1.3 and §2.2.4.

²¹ Appendix II: Annex II; Figure 2.2.

3.4.4 Upper legform to bonnet leading edge test

The impact conditions of the upper legform to bonnet leading edge test are dependent on the shape of the vehicle to be tested.

The bonnet leading edge height and the bumper lead are determined²² and based on these values the impact velocity (20-40 km/h), the impact angle (10-47.4°) and the impact energy are determined²³. The impact mass (9.5-17.7 kg) is calculated from the impact velocity and energy, and small adjustments are allowed to obtain standard increments of adjustable mass.

The impact direction is in the fore/aft vertical plane of the vehicle. Small tolerances to this direction are allowed. The impact position in the 'horizontal' direction of this guided impact is already described in §3.2. The centre of the impactor should be aligned with the bonnet leading edge²⁴.

3.4.5 Headform to bonnet top test

It is known from cadaver tests and mathematical model simulations that the head to bonnet impact velocity can be up to 20% higher than the vehicle impact speed [14]. This would mean a headform impact velocity of 48 km/h for a simulated 40 km/h pedestrian accident. EEVC WG10 decided to describe an impact velocity of 40 km/h for both the child and the adult headform to bonnet tests, because:

- headform impactor tests to a car body shell with the internal components removed have shown that it would be difficult to achieve a HIC value of less than 1000 from headform impact velocities of 45 km/h or greater;
- there is a trend to design passenger cars with a more 'vertical' bonnet top, resulting in head impact velocities similar to the vehicle impact speed.

The direction of impact is rearward and downward, at an angle of 50 degrees to the horizontal for the child headform tests and at an angle of 65 degrees for the adult headform tests. The impact direction is in the fore/aft vertical plane of the vehicle. Small tolerances to these directions are allowed.

The impact point on the car is defined by the point of first contact between the circumference of the headform impactor and the bonnet top. For tests to the windscreen lower frame the headform impactor should not contact the windscreen glass before impacting the vehicle structure²⁵.

²² Appendix II: Annex I; §2.

²³ Appendix II: Annex II; Figures 2.5, 2.6 and 2.7.

²⁴ Appendix II: Annex II; Figures 2.4.

²⁵ Appendix II: Annex II; §6.4.2.2.

3.5 Requirements

3.5.1 Legform to bumper test

Soft tissue 'crush' injuries caused by flat bumpers were discussed within WG10. Based on an expert classification [23], it was decided to give first priority to avoidance of knee ligament rupture and bone fractures.

The proposed acceptance levels are 15 degrees of lateral knee bending rotation, 6 mm of lateral knee shearing displacement and 150 g lateral acceleration at the top of the tibia²⁶. The 150 g acceleration value is aimed to limit the contact force applied to the tibia. The bending angle is associated with the bending moment at knee level and assesses the risk for ruptures of the knee ligaments. The acceptance level is based on cadaver tests [24].

In the second report of WG10 [14] an angle of 5 degrees was mentioned as acceptance level for shear rotation, which was based on impact forces of 4 kN and lateral shear displacements of 5-6 mm in cadavers. According to autopsies made after these tests it was found that rupture of the anterior cruciate ligament (ACL) is the typical injury associated with shearing mechanisms. When pulled it can be considered that about 25-30 mm of the ligament is lengthened and with an elongation at rupture of 20% [18], this corresponds to a limit of 5-6 mm for shearing displacement.

3.5.2 Upper legform to bonnet leading edge test

Based on pedestrian accident reconstructions and confirmed by available results from cadaver tests [8], acceptance levels are proposed by EEVC WG10: a total (instantaneous) force of 4kN and a bending moment of 220 Nm (measured at one or more strain gauges)²⁷.

3.5.3 Headform to bonnet top test

Rotational accelerations have been discussed by EEVC WG10, however, it was concluded that insufficient data is available to propose an acceptance level. Therefore only linear accelerations are measured and used; the proposed acceptance level is that the Head Performance Criterion, calculated from the resultant acceleration of the headform accelerometer time histories shall not exceed 1000²⁸.

Confirmation is still necessary for the child acceptance level of 1000, although it is mentioned in literature that "A HIC value of 1000, when used with the NHTSA head impact system, was verified as an accurate indicator of the threshold of serious head injury through experimental reconstruction of real pedestrian cases involving adults and children" [25].

²⁶ Appendix II: Annex I; §5.2.

²⁷ Appendix II: Annex I; §5.3.

²⁸ Appendix II: Annex I; §5.4 and §2.5.

3.5.4 Phasing of requirements

Because problems may arise for car manufacturers in obtaining the required safety levels (see also § 4.6), a phased-in introduction of the requirements seems feasible. This means that a certain percentage of the test area (or of the number of tests) should fulfil the requirements of that area and the remaining percentage could fail. This latter percentage can be decreased in a certain time period after introduction of the regulation.

4 EVALUATION OF TEST METHODS

4.1 Introduction

WG10 restarted at the end of 1991 and since then the proposed test methods, including sub-system impactors, have been evaluated thoroughly. Improvements have been included in the design of the impactors and in the test procedures.

In this chapter a summary of some evaluation programmes will be presented, as well as the performance of current passenger cars in these tests.

4.2 Legform to bumper test

Computer model simulations showed good results of the leg-model when compared with a complete dummy-model, if the bumper impact occurs below the knee level. With impacts above the knee level the leg-model showed somewhat lower responses [26]. It is felt that the test procedure allows for evaluation of car bumpers at 500 mm above ground level or below²⁹.

The legform impactor has been used by INRETS in several tests with different passenger cars. These tests did not show any important problems concerning durability and repeatability. Tests on the same car with different bumper heights showed the sensitivity of the test method and impactor design to this parameter which is directly related to the risk of knee injuries [15]. Large differences in bending angle and shearing displacement were also found when the bumper is impacted in the middle (far from the bumper attachment) or in front of the bumper fixation, which is a much stiffer area.

TRL [27] has evaluated the test procedure and concluded that the prescribed procedure was clear and easy to follow. It was stated that the number of tests required, combined with the selection of points most likely to cause injury, gives a reasonable coverage of the bumper. One recommendation was made in that respect and later on included in the procedure; since the outer thirds of the car are most likely to be symmetrical, a different test side should be selected (see §3.2). Coefficients of variation for a test series on a simulated vehicle were 4% for bending, 9% for shear and 4% for acceleration. It was concluded that the impactor design has a robust appearance. Several recommendations were given to further improve the impactor design and were included in the latest version (see § 3.3.1).

BAST [22] performed tests according to the EEVC method, without having previous experience and using a different propulsion system to INRETS. BAST concluded that the definitions and corresponding measurements on the car were simple. The durability of the impactor was good.

²⁹ If the bumper is located at 600 mm from the ground level, the upper leg test procedure applies, as described in §3.2.1.

A statement on repeatability of the test method could not be given, but it was found that it is not easy to keep inside the tolerances for impact height and vertical impact angle. However, BAST used a free flight distance of 1 m for the impactor, as described in earlier versions of the test method, while no minimum distance is prescribed in the latest version³⁰. It is expected that the repeatability of the test method will improve by that change [22].

4.3 Upper legform to bonnet leading edge test

In 1992, TRL evaluated the existing version of the test method and concluded that the test procedure, vehicle measurement and look-up methods proved easy to understand and use [28]. Some improvements, however, were proposed by TRL and accepted by WG10; a definition of the corner reference points and a minimum impact distance from these points³¹, and an additional requirement to cover repairs between tests³².

BAST [22] performed tests according to the EEVC method. BAST concluded that the definitions and corresponding measurements on the car were simple. The durability of the impactor was good. The repeatability of the test method was considered good, with only small differences in test results (i.e. 2%) between two similar tests.

4.4 Headform to bonnet top test

TRL has evaluated the test method and concluded that the procedures for identifying the test area were clear and easy to follow, the selection of test sites and the requirements for setting up and testing the car were also clear and easy to follow [29]. Only one point in the test procedure was found to require clarification; the difference between the centre of the dent on the bonnet and the line of free flight of the headform. Based on the TRL recommendation, WG10 defined the 'point of impact' as the 'point of first contact'³³. It was concluded that the repeatability of the impactors and test method was good.

4.5 Bull-bars

TRL and BAST performed several tests on so-called bull-bars or crash-bars fitted to the front of off-road vehicles. Tests with the upper legform impactor [30, 31] and tests with the child headform impactor [31, 32] showed how pedestrian unfriendly these bent and welded steel tubes are.

³⁰ Appendix II; Annex II; §3.1.2.

³¹ Appendix II; Annex I; §2.4.3 and Annex II; §5.4.2.2.

³² Appendix II; Annex I; §3.5.

³³ See §3.4.5.

Tests with the legform impactor showed, surprisingly, a decrease in bending angle and shearing displacement compared with the same off-road vehicle without a crash-bar. However, the tibia acceleration was increased indicating the higher stiffness of the crash-bar [31].

In Germany the percentage of off-road vehicles in the total number of cars is above 1% and approximately 62% are equipped with crash-bars. It is suggested that the proposed regulation should not only cover manufacturer mounted crash-bars, but be extended to cover also crash-bars fitted as after-market accessories [30].

4.6 Current vehicles

The performance of current vehicles with respect to the proposed test methods has been evaluated also by WG10 in several programmes.

Tests performed by INRETS showed that lowering the bumper of a medium size mass-production car by 88 mm can decrease the bending angle and shearing displacement in the legform to bumper test by more than 50%. It is concluded that it is possible to optimise the design of car front ends in terms of shape and materials to improve the protection of pedestrians against leg injuries [15].

Leg-to-bumper tests performed by the BASt according to the EEVC test method on three different cars, showed that none of the cars passed all three requirements in all three bumper tests. However, every car showed in at least one test that one or two requirements can be fulfilled [22]. It should be remembered that these cars are not designed for pedestrian protection.

TRL performed three tests on the bonnet leading edge of four popular European cars [28]. For one of the three tests to each car a 'weak' test point was selected rather than the point most likely to cause injury. This was done to get a measure of the best performance achieved by current cars. All cars exceeded the proposed acceptance levels. All four cars had heavy under-bonnet reinforcement which was carried right to the bonnet leading edge. Relatively simple changes to the car/bonnet design, such as moving the reinforcement back from the leading edge, would probably be sufficient to pass the test [28].

Upper legform to bonnet leading edge tests on three different cars have been performed by the BASt. Large differences in test results were found between tests on different points of one car and between different cars. All requirements were passed in one test on one of the 3 cars [22].

In 1992 BASt performed a series of headform impactor tests on 9 (popular) cars [33]. Only the bonnet (i.e. the moving part) was used as test area and not the wings, scuttle, etc. All points which seemed to be dangerous were tested with no restriction to the number of tests in each sub-area (as described by the EEVC test method). In 42% of all tests with the adult headform, the HIC was less than 1000, and in 31% the HIC was between 1000 and 1500. For the child headform tests, only 14% resulted in a HIC value below 1000, while in 48% of these tests the result was between 1000 and 1500. Large differences between cars were found; from 83% below HIC 1000 for one car to 100% above HIC 1500 for another car.

By means of double integration of the acceleration time histories, it was found that for obtaining a $HIC \leq 1000$ in the child head impact test a minimum distance of 50 mm is required between the bonnet and a stiff under-bonnet surface, for the adult head impact test 70 mm is sufficient [34]. Theoretical studies showed that with even less distance to the substructure the requirement can be met [35].

TRL performed headform impacts on 4 cars according to the EEVC test method [36]. Since the adult test area was narrow on all cars and to reduce costs of testing, it was decided to reduce the number of adult headform tests. None of the tests resulted in HIC values below 1000, however, several test sites came close to passing the requirements, taking the non-linear effects of the HIC calculation into account. One car was close to passing at most test sites.

Results of headform-to-bonnet tests on a 4x4 utility vehicle with an aluminium bonnet were discussed within WG10. In one out of four child headform tests and one out of four adult headform tests the requirement was fulfilled.

4.7 Conclusions

The 3 test methods have been evaluated in several research programmes performed with real vehicles. Several improvements have been discussed and subsequently included in up-dated versions of the test methods. The procedures seem easy to follow and the test methods appear to be reproducible and sensitive to vehicle design changes.

Several test programmes to current cars have shown that it is technically possible to fulfil the requirements proposed in the EEVC test method with new car designs. Several design guidelines have been developed, based on the experience gained in these programmes [37]. The proposed lead-time for this Directive is such that it would not normally be necessary to modify current car designs.

5 COST BENEFIT STUDIES

Introduction of the EEVC pedestrian test methods as a Directive should reduce the large number of killed and seriously injured pedestrians in Europe. Indications for savings were already given in the previous reports of WG10 [12, 14].

Since then several members of EEVC WG10 have been involved in cost-benefit studies concerned with the proposed regulation. These studies [38, 39, 40] have been discussed within WG10, however, since cost-benefit studies were not part of the terms of reference of the working group no results will be presented here.

6 CONCLUSIONS

EEVC Working Group 10 started its activities in 1988 with the task *'to determine test methods and acceptance levels for assessing the protection afforded to pedestrians by the fronts of cars in an accident. The test methods should be based on sub-system tests, essentially to the bumper, bonnet leading edge and bonnet top surface.* The studies necessary to develop test methods were already presented in a *first* report of EEVC WG10, published in 1989 [5]. The first results of the studies and the first version of the test methods was described in the *second* WG10 report, published in 1991 [14].

Since then the proposed test methods, including the sub-system impactors, have been evaluated thoroughly. Improvements have been included in the design of the impactors and in the test procedures. The procedures seem easy to follow and the test methods appear to be reproducible and sensitive to vehicle design changes.

The headform and upper legform impactors are now available on a commercial basis. Prototype legform impactors have been available for some time and it is expected that a final version could be available in the Spring of 1995. The final static and dynamic certification requirements of this impactor could than be defined. The whole text of the test methods is included in Appendix II of this report.

Several test programmes to current cars have shown that it is technically possible to fulfil the requirements proposed in the EEVC test method with new car designs, however, a phased-in introduction of the requirements seems feasible. It is suggested that the proposed regulation to be extended to cover also crash-bars or bull-bars fitted as after-market accessories, since several test programmes have shown how pedestrian unfriendly these (steel) bars are.

The pedestrian protection methods discussed in this report are only intended for the fronts of cars up to a wrap around distance of 2100mm or to the base of the windscreen if this is less. However, other parts of cars are also responsible for severe or fatal pedestrian injuries: the A-pillar, windscreen and upper windscreen frame. Buses and coaches, heavy good vehicles and motorcycles are also involved in a considerable number of pedestrian accidents. Thus, further research is required in these area's.

REFERENCES

1. European Experimental Vehicles Committee:
Pedestrian injury accidents.
Presented to the 9th ESV Conference, Kyoto, November 1982.
2. European Experimental Vehicles Committee:
Cycle and light-powered two-wheeler accidents.
Presented at the 9th IRCOBI Conference, Delft, September 1984.
3. European Experimental Vehicles Committee:
Pedestrian injury protection by car design.
Presented to the 10th ESV Conference, Oxford, July 1985.
4. Commission of the European Communities:
Frontal surfaces in the event of impact with a vulnerable road user.
Ad-hoc Working Group ERGA Passive Safety, document ERGA S/60, Brussels.
5. European Experimental Vehicles Committee:
Study of test methods to evaluate pedestrian protection for cars.
EEVC Working Group 10 report, presented to the 12th ESV Conference, Gothenburg, May 1989.
6. Janssen, E.G., Nieboer, J.J.:
Protection of vulnerable road users in the event of collision with a passenger car, Part I - Computer simulations.
TNO Report No. 75405002/I under Contract No. ETD/89/7750/M1/28 to the European Commission, December 1990.
7. Janssen, E.G. et al.:
Protection of vulnerable road users in the event of collision with a passenger car, Part II - Sub-systems test method evaluation and compatibility study.
TNO Report No. 75405002/II under Contract No. ETD/89/7750/M1/28 to the European Commission, December 1990.
8. Lawrence, G.J.L. et al.:
Development of a bonnet leading edge sub-systems test to assess protection for pedestrians.
TRRL report under Contract No. ETD/89/7750/M1/28 to the European Commission, January 1991.
9. Glaeser, K.-P.:
Development of a Head Impact Test Procedure for Pedestrian Protection.
BAST report under Contract No. ETD/89/7750/M1/28 to the European Commission, June 1991.
10. Cesari, D., Alonzo, F.:
Assessment of Test Methods to evaluate the protection afforded to pedestrians by cars.
INRETS report under Contract No. ETD/89/7750/M1/28 to the European Commission, December 1990.
11. Brun-Cassan, F.:
Assessment of Test Methods to evaluate the protection afforded to pedestrians by cars - Compatibility.
APR report under Contract No. ETD/89/7750/M1/28 to the European Commission, July 1991.
12. Commission of the European Communities:
Summary of the work of the consortium developing test methods to evaluate the protection afforded to pedestrians by cars (including test proposals).
European Commission Study Contract No: ETD/89/7750/M1/28, July 1991.

13. Commission of the European Communities:
Draft proposal for a Council Directive adapting to technical progress Council Directive 74/483/EEC relating to the external projections of motor vehicles including their effect on pedestrians.
Document III/4025-92, Brussels, April 1992.
14. European Experimental Vehicles Committee:
Proposals for test methods to evaluate pedestrian protection for cars.
EEVC Working Group 10 report, presented to the 13th ESV Conference, Paris, November 1991.
15. Cesari, D. et al.:
Optimization of pedestrian leg injury protection using a biofidelic human leg.
Presented at the 1994 International Conference on the Biomechanics of Impacts, Lyon, September 1994.
16. Robbins, D.H.:
Development of anthropometrically based design specifications for an advanced adult anthropomorphic dummy family.
Report no. UMTRI-83-53-2, Ann Arbor, 1983.
17. Cavallero, C., Cesari, D.:
Pedestrian Leg Injures - Mechanisms and Tolerance.
INRETS report LCB 9309 bis, July 1994.
18. Yang, J.:
Impact Biomechanics of the Lower Extremity in Traffic Accidents - Development and Validation of a Mathematical Model.
Chalmers University of Technology, Thesis, Gothenburg, March 1994.
19. Lawrence, G. J.L.:
Personal communication to EEVC WG10 chairman.
Crowthorne, October 1994.
20. Zellmer, H.:
Static knee bending moment volunteer tests - Personal communication to EEVC WG10 chairman.
Bergisch Gladbach, October 1994.
21. Lawrence, G.J.L., Hardy, B.J.:
An improved certification method for the pedestrian upper legform impactor.
EEVC WG10 document, 13-9-1994.
22. Zellmer, H.:
Evaluierung des Prüfverfahrens der EEVC WG10 zur Bestimmung der Fußgängerverträglichkeit von Pkw-Frontflächen (Evaluation of the EEVC WG10 test methods to assess the protection afforded to pedestrians by the front of cars).
BASt report, July 1994.
23. Cavallero, C.:
Inventory of possible injures on the pedestrian lower-limb level - Personal communication to EEVC WG 10.
INRETS, Marseille, 1992.
24. Cesari, D. et al.:
Mechanisms producing lower extremity injuries in pedestrian accident situations.
Proceedings of the 33rd AAAM Conference, Baltimore, 1989.

25. Laughlin, T.F., Kessler, J.W.:
Pedestrian Head Impact Against the Central Hood of Motor Vehicles - Test procedure and results.
SAE paperno. 902315, presented at the 34th Stapp Car Crash Conference, Orlando, November 1990.
26. Cesari, D. et al.:
Subsystem test for pedestrian lower leg and knee protection.
Presented to the 13th ESV Conference, Paris, November 1991.
27. Lawrence, G.J.L., Hardy, B.J.:
Evaluation of the leg to bumper impactor proposed for the EEVC pedestrian impact test procedure.
TRL project report PR/VE/66/93, S220C/NF, 1993.
28. Lawrence, G.J.L., Hardy, B.J.:
Report on tests using the draft directive for pedestrian protection on cars.
EEVC WG10 document, 25-11-1992.
29. Lawrence, G.J.L., Hardy, B.J.:
Evaluation of the head impactors proposed for the EEVC pedestrian impact test procedure.
TRL project report PR/VE/34/93, S220C/NF, 1993.
30. Lawrence, G.J.L., Hardy, B.J.:
Vehicle crash bars - Assessment of pedestrian injury potential.
TRL working paper WP/VS/225, S220C/NF, 1992.
31. Zellmer, H.:
Quantifizierung der Gefährdung von Fußgängern durch Frontschutzbügel an Geländefahrzeugen (Assessment of pedestrian protection afforded by crash-bars).
BASt report, Arbeitsprogramm-Nr.: 94 552, August 1994.
32. Zellmer, H.:
Test on crash bars for off-road vehicles with the EEVC WG10 child head form.
BASt report, June 1993.
33. Zellmer, H., Glaeser, K.-P.:
Performance of current cars in pedestrian accidents tested with the proposed EEVC head impactor.
BASt report, November 1992.
34. Zellmer, H., Glaeser, K.-P.:
The EEVC WG10 head impact test procedure in practical use.
Presented to the 14th ESV Conference, Munich, May 1994.
35. Okamoto, Y. et al.:
Concept of hood design for possible reduction in pedestrian head injury.
Presented to the 14th ESV Conference, Munich, May 1994.
36. Lawrence, G.J.L., Hardy, B.J.:
Evaluation of four cars using the EEVC pedestrian head impact test procedure.
TRL project report PR/VE/76/94, S220C/NF, 1994.
37. Lawrence, G.J.L., Hardy, B.J.:
Final report on pedestrian protection test procedures and design.
TRL project report PR/VE/81/94, S220C/NF, 1994.
38. Association des Constructeurs Europeens d'Automobiles:
Pedestrian Accidents in Europe - Developments and Challenges.
ACEA report, Brussels, September 1992, updated September 1993.

39. Lawrence, G.J.L et al.:

Costs and benefits of the EECV pedestrian impact requirements.

TRL project report 19, S220CVF, Crowthorne, 1993.

40. Bamberg, R., Zellmer, H.:

Nutzen durch fahrzeugseitigen Fußgängerschutz (Benefits from Vehicle-Pedestrian Protection Measures).

Berichte der BAST, Fahrzeugtechnik Heft F5, Bergisch Gladbach, April 1994.

APPENDIX I**Members/attenders of EEVC WG10 in 1991-1994**

E. Faerber	BASt
M. Beusenberg	TNO (secr.)
mrs. F. Brun-Cassan	LAB (LCB/APR)
Y. Caire	INRETS
D. Cesari	INRETS
A. Giles	SMMT/Rover
K.-P. Glaeser	BASt
P. Goudswaard	TNO (secr.)
N. Grew	SMMT/Rover
B. Hardy	TRL
W. Heiss	Mercedes-Benz
E. Janssen	TNO (chairman)
G. Lawrence	TRL
R. Lowne	TRL
P. Massaia	FIAT
mrs. I. Skogsmo-Planath	Volvo Car Corp.
A. Saladin	TNO (secr.)
R. Worth	DoT/UK
H. Zellmer	BASt

APPENDIX II

Proposal for test methods

**FRONTAL SURFACES IN THE EVENT
OF IMPACT WITH A
VULNERABLE ROAD USER**

PROPOSAL FOR TEST METHODS

EEVC WG 10

21 November 1994

ANNEX I

SCOPE, DEFINITIONS, APPLICATION FOR EC TYPE-APPROVAL, SPECIFICATIONS, TESTS AND CONFORMITY OF PRODUCTION

1. SCOPE

- 1.1. This Directive applies to the frontal surfaces of vehicles in categories M₁, and to N₁ vehicles derived from M₁ as defined in Annex I of Directive 70/156.
- 1.2 This Directive has the purpose of reducing injuries to pedestrians and other vulnerable road users who are hit by the frontal surfaces of the vehicles defined in paragraph 1.1.

2. DEFINITIONS

- 2.1.1 When performing measurements on the vehicle as described in this Annex, the vehicle should be positioned in its normal ride attitude as described in paragraph 2.1.2.
- 2.1.2 'Normal ride attitude' is the vehicle attitude in running order positioned on the ground, with the tires inflated to the recommended pressures, the front wheels in the straight-ahead position, with maximum capacity of all fluids necessary for operation of the vehicle, (with all standard equipment as provided by the vehicle manufacturer), with a 75 kg mass placed on the driver's seat and with a 75 kg mass placed on the front passenger's seat, and with the suspension set for a driving speed of 40 km/h in normal running conditions specified by the manufacturer (especially for vehicles with an active suspension or a device for automatic levelling).
- 2.2 'Bumper' is for this Directive the front, lower, outer structure of a vehicle. It includes all structures that are intended to give protection to a vehicle when involved in a low speed frontal collision with another vehicle and also any attachments to this structure. The reference height and lateral limits of the bumper are identified by the corners and the bumper reference line as defined in paragraph 2.2.1, 2.2.2 and 2.2.3.
- 2.2.1 'The Bumper Reference Line' identifies the significant points of pedestrian contact with the bumper. It is defined as the geometric trace of the upper most points of contact between a straight edge 700 mm long and the bumper, when the straight edge, held parallel to the vertical longitudinal plane of the car and inclined rearwards by 20°, is traversed across the front of the car, while maintaining contact with the ground and with the surface of the bumper (see Figure 1.1).

Where necessary the straight edge shall be shortened to avoid any contact with structures above the bumper.

- 2.2.2 'Bumper Height' is the vertical distance between the ground and the bumper reference line, defined in paragraph 2.2.1 with the vehicle positioned in its normal ride attitude.
- 2.2.3 'Corner of Bumper' is defined as the vehicle's point of contact with a horizontal straight edge 700 mm long, that falls inside a vertical plane which makes an angle of 60° with the vertical longitudinal plane of the car and is tangential to the outer surface of the bumper (see Figure 1.2).
- 2.2.4 'Ground Reference Level' is the horizontal plane parallel to the ground level, representing the ground level for a vehicle placed at rest on a flat surface with the handbrake on, with the vehicle positioned in its normal ride attitude.
- 2.2.5 A 'Third of the bumper' is defined as the geometric trace between the 'Corners of the bumper', measured with a flexible tape following the outer contour of the bumper, divided in 3 equal parts.
- 2.3 'Bonnet Leading Edge' for this Directive is the front upper outer structure including the bonnet and wings, the upper and side members of the headlight surround and any other attachments. The reference line identifying the position of the leading edge is defined by its height above the ground and by the horizontal distance separating it from the bumper (bumper lead), determined in accordance with paragraph 2.3.1, 2.3.2 and 2.3.3.
- 2.3.1 'Bonnet Leading Edge Reference Line' is defined as the geometric trace of the points of contact between a straight edge 1000 mm long and the front surface of the bonnet, when the straight edge, held parallel to the vertical longitudinal plane of the car and inclined rearwards by 50° and with the lower end 600 mm above the ground, is traversed across and in contact with the bonnet leading edge (See Figure 1.3). For vehicles having the bonnet top surface inclined at essentially 50° or less to the vertical, determine the reference line with the straight edge inclined at an angle of 40°.
- The top edge of the bumper shall be regarded as the bonnet leading edge for this Directive, if it is contacted by the straight edge during this procedure.
- 2.3.2 'Bonnet Leading Edge Height' for any section of a car is the vertical distance between the ground and the bonnet leading edge reference line defined in paragraph 2.3.1, with the vehicle positioned in its normal ride attitude.
- 2.3.3 'Bumper Lead' for any section of a car is the horizontal distance between the bumper reference line, as defined in paragraph 2.2.1 and the bonnet leading edge reference line, as defined in paragraph 2.3.1.
- 2.3.4 A 'Third of the bonnet leading edge' is defined as the geometric trace between the 'Corner reference points' as defined in paragraph 2.4.3, measured with a flexible tape following the outer contour of the leading edge, divided in 3 equal parts.

2.4 'Bonnet top' in this Directive is the outer structure that includes the upper surfaces of the bonnet and of the wings, the scuttle and the lower edge of the windscreen. It is bounded by the geometric trace of the 1000 mm and 2100 mm wrap around distances in the front and rear, as defined in paragraph 2.4.1, and the bonnet side reference lines, as defined in paragraph 2.4.2. When the windscreen extends forward of the 2100 mm wrap around distance, then the windscreen lower frame shall be the rear boundary.

2.4.1 '1000 mm Wrap Around Distance' is the geometric trace described on the top of the bonnet by one end of a 1000 mm long flexible tape, when it is held in a vertical fore and aft plane of the car and traversed across the front of the bonnet and bumper. The tape is held taut throughout the operation with one end held in contact with the ground, vertically below the front face of the bumper and the other end held in contact with the bonnet top (see Figure 1.4). The vehicle is positioned in the normal ride attitude.

Similar procedures shall be followed, using alternative tapes of appropriate lengths to describe 1500 and 2100 mm wrap around distances.

2.4.2 'Bonnet Side Reference Line' is defined as the geometric trace of the highest points of contact between a straight edge 700 mm long and the side of a bonnet, when the straight edge, held parallel to the lateral vertical plane of the car and inclined inwards by 45° is traversed down the side of the bonnet top, while maintaining contact with the surface of the body shell (see Figure 1.5).

2.4.3 'Corner reference point' is the intersection of the bonnet leading edge reference line and of the bonnet side reference line (see Figure 1.6).

2.4.4 A 'Third of the bonnet top' is defined as the geometric trace between the 'Bonnet side reference lines', measured with a flexible tape following the outer contour of the bonnet top, divided in 3 equal parts.

2.5 Head Performance Criteria (HPC) shall be calculated from the resultant of accelerometer time histories as the maximum (depending on t1 and t2) of the equation:

$$HPC = \left[\frac{1}{t_2 - t_1} \int_{t_1}^{t_2} a \, dt \right]^{2.5} (t_2 - t_1) \max$$

where 'a' is the resultant acceleration as a multiple of 'g' and t1 and t2 are any points in time (expressed in seconds) during the impact.

3. APPLICATION FOR EC TYPE APPROVAL

3.1 The application for EC type-approval of a vehicle type with regard to the behaviour of the frontal surfaces in the event of an impact with a vulnerable road user, shall be submitted by the vehicle manufacturer or his duly accredited representative.

- 3.2 Separate applications will be required for each model variation that has different engine or other under-bonnet component, component location, front structure or outer frontal surfaces, or different ride heights.
- 3.3 It shall be accompanied by the undermentioned documents in triplicate and the following particulars:
- 3.3.1 general arrangement drawings of the vehicle structure on an appropriate scale, showing the front half of the car including the outline of the engine, and detailed technical descriptions and drawings of all parts of the front of the car that may be involved in a frontal impact with a vulnerable road user;
- 3.3.2 a specification of all material used which may affect the performance of the vehicle to be tested.
- 3.4 The following must be submitted to the technical service responsible for conducting the approval tests:
- 3.4.1 a vehicle, which is representative of the vehicle type to be approved for the tests referred to in item 5.2, 5.3 and 5.4;
- 3.4.2 or a sub-section of the vehicle to be approved for the tests referred to in item 5.2, 5.3 and 5.4, provided that it complies with the conditions detailed in paragraph 2.2.1 of Annex II and provided that it can be shown that the absence of the components omitted has no effect on the performance prescribed in the requirements of this Directive;
- 3.4.3 plus duplicates of those parts of the vehicle regarded as essential to complete the tests referred to in item 5.2, 5.3 and 5.4.
- 3.4.4 It shall be the responsibility of the applicant for approval to show that the application of paragraph 3.4.2 is compatible with compliance with the requirements of this Directive.
- 3.5 The competent authorities should satisfy themselves that the vehicle for the second and subsequent tests, whether repaired or not, is still representative of the type for the purpose of the test.

4. APPROVAL

- 4.1 A form conforming to the model set out in Annex IV must be attached to the EC type-approval certificate.
- 4.2 In case of doubt, account shall be taken, when verifying the conformity of the vehicle to the requirements of this Directive of any data or test results provided by the manufacturer which can be taken into consideration in validating the approval test carried out by the technical service.
- 4.3 New approvals for model variations shall be added to the documents of the type approval.

5. SPECIFICATIONS

- 5.1 Compliance with the requirements of paragraphs 5.2, 5.3 and 5.4 shall be checked in accordance with the methods set out in Annex II.
- 5.2 In legform to bumper tests at impact speeds of 40 km/h; the maximum dynamic knee bending angle shall not exceed 15°, the maximum dynamic knee shearing displacement shall not exceed 6 mm, and the acceleration measured at the upper end of the tibia shall not exceed [150 g]¹.
- 5.3 In upper legform to bonnet leading edge tests at impact speeds up to 40 km/h, depending on the shape of the vehicle, the instantaneous sum of the impact forces with respect to time, to the top and the bottom of the impactor shall not exceed [4 kN] and the bending moment on the impactor shall not exceed [220 Nm].
- 5.4 In adult headform to bonnet top tests at an impact speed of 40 km/h, the Head Performance Criteria (HPC), calculated from the resultant of the headform accelerometer time histories, in accordance with paragraph 2.5, shall not exceed 1000, for the child headform to bonnet top tests HPC shall not exceed [1000] .

6. MODIFICATION OF THE VEHICLE

- 6.1 Any modification affecting the structure, the dimensions, the materials, or the position of parts which might affect the performance of the vehicle when impacting a vulnerable road user, shall be brought to the notice of the administrative department granting approval. The department may then either:
- 6.1.1 consider that the modifications made are unlikely to have an appreciable adverse effect and that in any case the vehicle still complies with the requirements; or
- 6.1.2 require the technical service responsible for conducting the tests, to carry out a further test, according to the nature of the modifications.
- 6.2 Confirmation or refusal of approval, specifying the alterations, shall be communicated by the form specified in Annex IV.

[] denotes values require confirmation

7. CONFORMITY OF PRODUCTION

- 7.1 Every vehicle prescribed under this Directive shall conform to the approved vehicle type, more particularly as regards features affecting the protection of vulnerable road users in the event of an impact by the front surface of the vehicle, and shall meet the requirements of paragraph 5 above.
- 7.2 The manufacturer shall carry out production inspections, tests or any checks which he deems necessary on components or pieces of equipment so as to ensure the conformity required in paragraph 7.1 above.
- 7.2.1 The results of these checks and tests shall be kept at the disposal of the administrative department which granted the approval.
- 7.2.2 If, after the above checks, it still appears that conformity is not certain, the administrative department may require a complete test to be carried out.

8. PENALTIES FOR NON-CONFORMITY OF PRODUCTION

- 8.1 The approval granted in respect of a vehicle type, pursuant to this Directive, may be withdrawn if the requirement laid down in paragraph 7.1 above is not complied with, or if the vehicle or vehicles selected have failed to pass the checks prescribed in paragraph 7.2 above.
- 8.2 If a Member State withdraws an approval it has previously granted, it shall forthwith so notify other Member States by means of a copy of the approval form bearing at the end in large letters the signed and dated statement "APPROVAL WITHDRAWN".

9. PRODUCTION DEFINITELY DISCONTINUED

- 9.1 If the holder of the approval completely ceases to manufacture the type of vehicle approved in accordance with this Directive, he shall so inform the authority which granted the approval, which shall in turn inform the other Member States by means of a copy of the approval form bearing at the end, in large letters, the signed and dated statement "PRODUCTION DISCONTINUED".

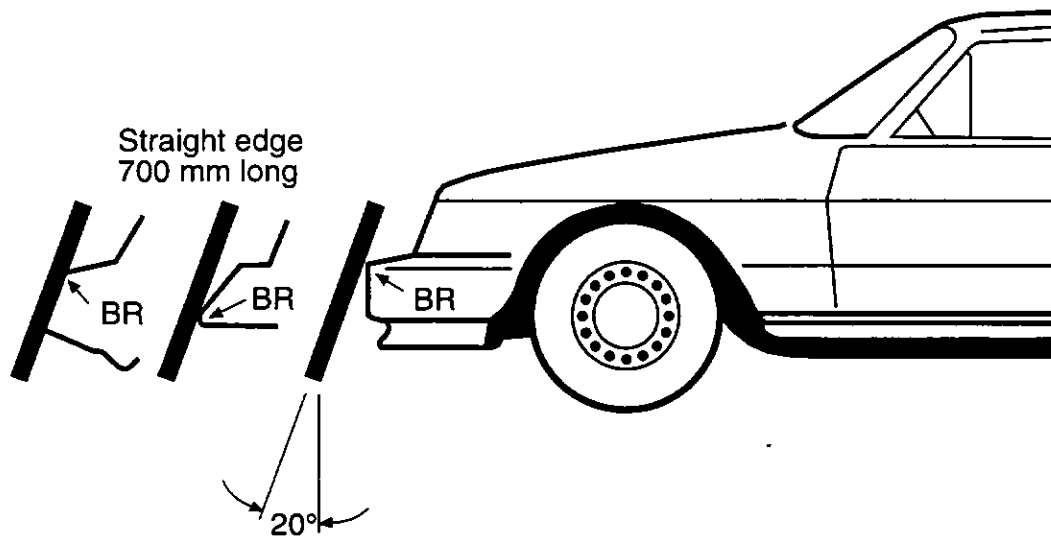

Figure 1.1 Determination of bumper reference line.

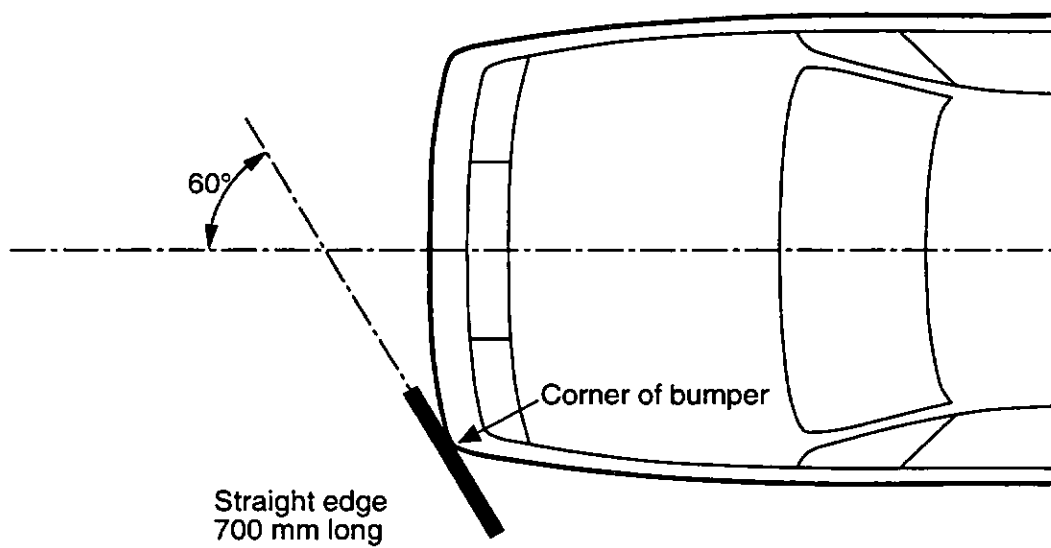

Figure 1.2 Determination of corner of bumper.

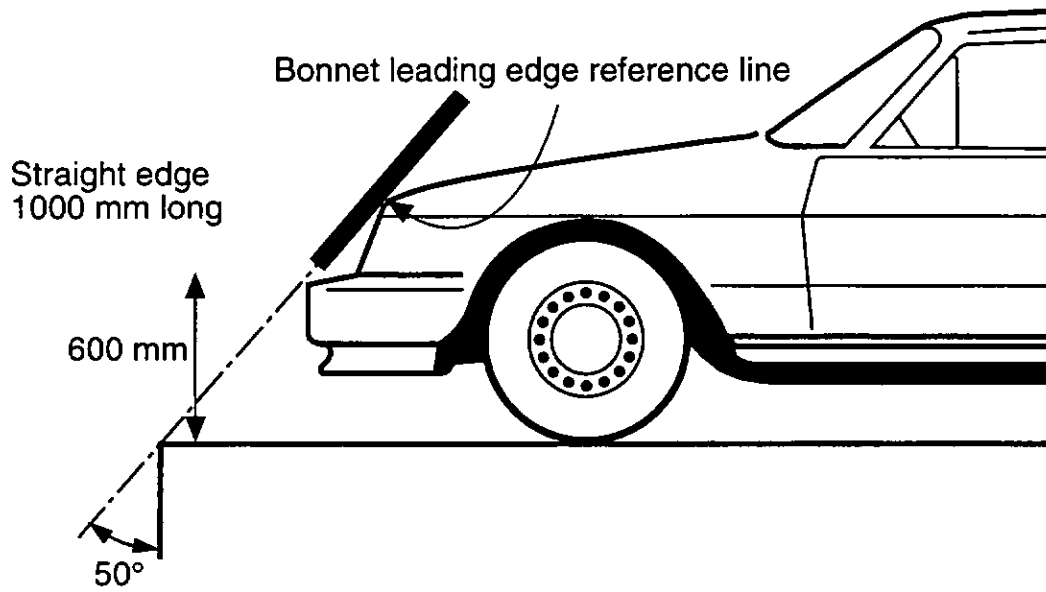

Figure 1.3 Determination of bonnet leading edge reference line.

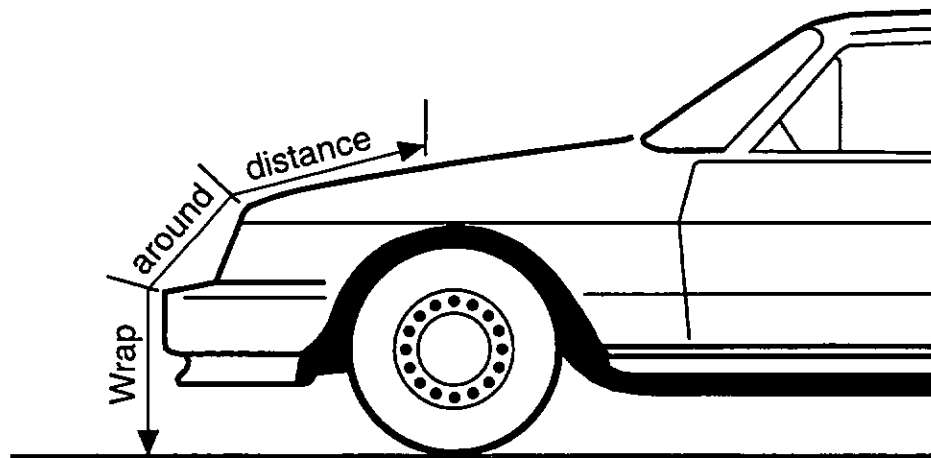

Figure 1.4 Determination of wrap around distance.

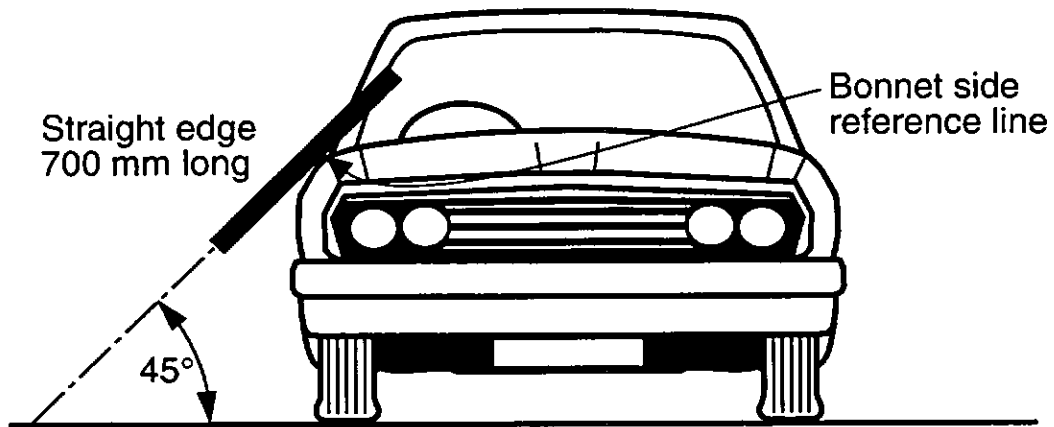

Figure 1.5 Determination of bonnet side reference lines.

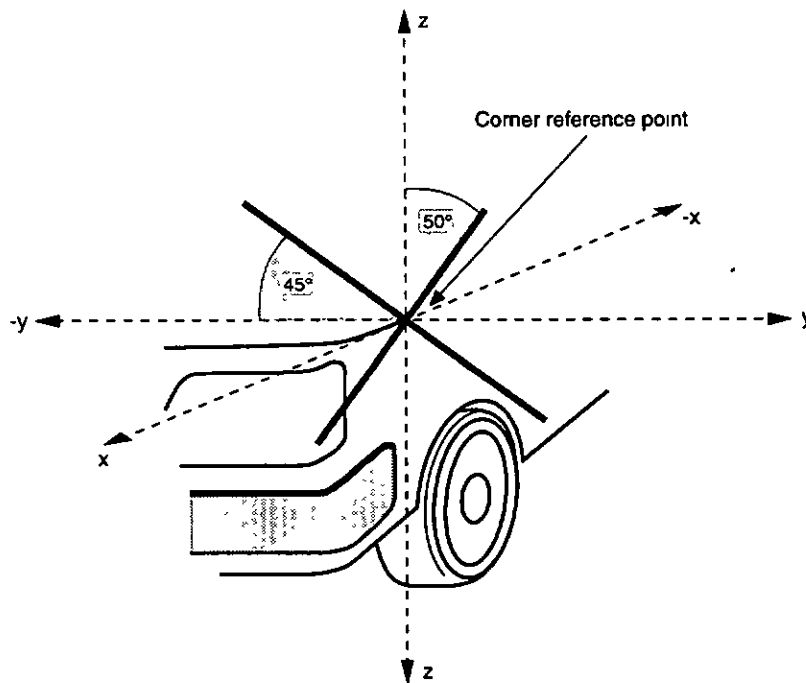

Figure 1.6 Determination of corner reference point; intersection of the bonnet leading edge reference line and the bonnet side reference line.

ANNEX II

REQUIREMENTS, EQUIPMENT, METHODS, RESULTS, ACCURACY AND EQUIVALENT PROCEDURES

1. PURPOSE

The bumper, bonnet leading edge and bonnet top shall be assessed against the requirements of paragraphs 5.2, 5.3 and 5.4 of Annex I, by the following tests.

2. STATE OF VEHICLE

2.1 Complete Vehicle. Tests on complete vehicles shall comply with the conditions detailed in paragraph 2.1.1 and 2.1.2.

2.1.1 The vehicle shall be in its normal ride attitude for legform to bumper tests defined in paragraph 4.4. The vehicle shall be either securely mounted on raised supports or at rest on a flat surface with the handbrake on.

2.1.2 The vehicle shall be securely mounted and comply with the requirements for direction and location of impact for the upper legform to bonnet leading edge and the headform to bonnet top tests defined in paragraphs 5.4 and 6.4. It is permissible to raise the rear-end of the vehicle in order to obtain the correct relative angle of impact between the impactor and the impacted vehicle. It shall be the responsibility of the applicant for approval to show that so raising the rear-end of the vehicle has no effect on the vehicle performance.

2.1.3 All devices designed to protect vulnerable road users shall be correctly activated before and/or be active during the appropriate test. It shall be the responsibility of the applicant for approval to show that the devices will activate as intended in a pedestrian impact.

2.2 Sub-System of Vehicle. Where only a sub-system of the vehicle is supplied for tests, it shall comply with the conditions detailed in paragraphs 2.2.1, 2.2.2 and 2.2.3.

2.2.1 All the parts of the vehicle structure and under bonnet components that may be involved in a frontal impact with a vulnerable road user shall be included in the test to demonstrate the performance and interactions of all the contributory vehicle components.

2.2.2 The vehicle sub-system shall be securely mounted in the normal vehicle ride attitude for legform to bumper tests defined in paragraph 4.4.

2.2.3 The vehicle sub-system shall be securely mounted and comply with the requirements for direction and location of impact for the upper legform to bonnet leading edge and the headform to bonnet top tests defined in paragraphs 5.4 and 6.4. It is permissible to raise the rear-end of the vehicle

sub-system in order to obtain the correct relative angle of impact between the impactor and the impacted vehicle sub-system. It shall be the responsibility of the applicant for approval to show that so raising the rear-end of the vehicle sub-system has no effect on the vehicle performance.

- 2.2.4 All devices designed to protect vulnerable road users shall be correctly activated before and/or be active during the appropriate test. It shall be the responsibility of the applicant for approval to show that the devices will activate as intended in a pedestrian impact.

3. PROPULSION SYSTEM

3.1 Application of Impactors

- 3.1.1 The upper legform impactor for the bonnet leading edge test shall be mounted to the propulsion system, by a torque limiting joint, to prevent large off centre loads damaging the guidance system. The guidance system shall be fitted with low friction guides that allow the impactor to move only in the specified direction of impact, when in contact with the vehicle.

- 3.1.2 The legform and headform impactors for the bumper and bonnet top tests shall be 'in free flight' at the moment of impact. The impactors shall be released to free flight at such a distance from the vehicle that the test results are not influenced by contact of the impactors with the propulsion system during rebound of the impactors.

3.2 Propulsion of Impactors

The impactors may be propelled by an air, spring or hydraulic gun, or by other means that can be shown to give the same result.

4. LEGFORM TO BUMPER TESTS

- 4.1 Purpose - to test for the requirements given in paragraph 5.2 of Annex I.

- 4.2 A minimum of three legform to bumper tests shall be carried out, one each to the middle and the outer thirds of the bumper, as described in paragraph 2.2.5 of Annex I, at positions judged to be the most likely to cause injury. Tests shall be to different types of structure, where they vary throughout the area to be assessed. The selected test points shall be a minimum of 130 mm apart, and a minimum of 75 mm inside the defined corners of the bumper. The positions tested by the laboratories shall be indicated in the test report.

- 4.3 Requirement - the bumper will satisfy the requirements of this Directive, if in the tests specified, the maximum dynamic bending angle and the maximum dynamic shearing displacement of the knee and the maximum acceleration measured at the upper end of the tibia, on the legform impactor, do not exceed the acceptance values given in paragraph 5.2 of Annex I.

4.4 Test Method

4.4.1 Test apparatus

4.4.1.1 The legform impactor shall consist of two foam covered rigid segments, representing femur (upper leg) and tibia (lower leg), joined by a deformable, simulated knee joint. The overall length of the legform impactor shall be 926 ± 5 mm, having a required test mass of 13.4 ± 0.1 kg and comply with the additional specifications of figure 2.1 including the notes.

4.4.1.2 Angular transducers shall be fitted to the femur and to the tibia. These shall be calibrated to measure the position of the femur and tibia relative to each other. One uniaxial accelerometer shall be fitted to the non-impacted side of the tibia, close to the knee joint, with its sensitive axis in the impact direction.

4.4.1.3 The instrumentation response values CFC and CAC shall be 180 Hz and 20° respectively for the angular transducers and 180 Hz and 500 g for the accelerometer, as defined in ISO 6487: 1987.

4.4.1.4 The legform impactor shall meet the performance requirement specified in paragraphs 1.2 and 2 of Annex III, and shall be fitted with foam cut from the sheet of material used for the dynamic certification test and fitted with deformable knee elements from the same batch as those used in the certification tests. The certified impactor may be used for a maximum of 20 impacts before re-certification. With each test new plastically deformable knee elements should be used. The impactor shall also be re-certified if more than one year has elapsed since the previous certification or if any impactor transducer output, in any impact, has exceeded the specified CAC.

4.4.1.5 The legform impactor shall be mounted, propelled and released as defined in paragraphs 3.1.2 and 3.2.

4.4.2 Test Procedure

4.4.2.1 The state of the vehicle or sub-system shall comply with the requirements of paragraphs 2.1 or 2.2 respectively. The stabilized temperature of the test apparatus and the vehicle or sub-system shall be $20^\circ \pm 4^\circ$ C.

4.4.2.2 Tests shall be made to the bumper between the corners, as defined in paragraph 2.2.3 of Annex I, to locations defined in paragraph 4.2.

4.4.2.3 The direction of impact shall be parallel to the longitudinal axis of the vehicle, with the axis of the legform vertical at the time of first contact.

4.4.2.4 The bottom of the legform impactor shall be at Ground Reference Level at the time of first contact with the bumper (see Figure 2.2), with a ± 10 mm tolerance.

When setting the height of the propulsion system, an allowance must be made for the influence of gravity during the period of free flight of the legform impactor.

At the time of first contact the impactor shall have the intended orientation about its vertical axis, for the correct operation of its knee joint, with a tolerance of $\pm 5^\circ$.

- 4.4.2.5 At the time of first contact the centre line of the legform impactor shall be within a ± 10 mm tolerance to the selected impact location.
- 4.4.2.6 During contact between the legform impactor and the vehicle, the legform impactor shall not contact the ground or any object not part of the vehicle.
- 4.4.2.7 The impact velocity of the legform impactor when striking the bumper shall be 11.1 ± 0.5 m/s.

5. UPPER LEGFORM TO BONNET LEADING EDGE TESTS

- 5.1 Purpose - to test for the requirements given in paragraph 5.3 of Annex I.
- 5.2 A minimum of three upper legform to bonnet leading edge tests shall be carried out, one each to the middle and the outer thirds of the bonnet leading edge, as described in paragraph 2.3.4 of Annex I, at positions judged to be the most likely to cause injury. Tests shall be to different types of structure, where they vary throughout the area to be assessed. The selected test points shall be a minimum of 150 mm apart, and a minimum of 75 mm inside the defined corner reference points. The positions tested by the laboratories shall be indicated in the test report.
- 5.3 Requirement - the bonnet leading edge will satisfy the requirements of this Directive if in the tests specified, the maximum sum of the impact forces to the top and the bottom of the upper legform impactor and the bending moments on the upper legform impactor do not exceed the acceptance values given in paragraph 5.3 of Annex I. A test is not required if the kinetic energy of impact, determined in paragraph 5.4.2.7 is 200 J or less.
- 5.4 Test Method
 - 5.4.1 Test apparatus
 - 5.4.1.1 The upper legform impactor shall be rigid, foam covered, and 350 ± 5 mm long (see Figure 2.3) and comply with the additional specifications of figure 2.3 including the notes.
 - 5.4.1.2 The upper legform impactor mass shall be dependent upon the general shape of the front of the car and determined as specified in paragraph 5.4.2.7.
 - 5.4.1.3 Two force measuring transducers shall be fitted to measure individually the forces applied at either end of the upper legform impactor, plus strain gauges measuring bending moments at the centre of the upper legform impactor and at positions 50 mm either side of the centre line, see Figure 2.3.

- 5.4.1.4 The instrumentation response values CFC shall be 180 Hz and CAC shall be 10 kN for force transducers and 1000 Nm for the bending moment measurements, as defined in ISO 6487: 1987.
- 5.4.1.5 The upper legform impactor shall meet the performance requirements specified in paragraphs 1.2 and 3 of Annex III, and shall be fitted with foam cut from the sheet of material used for the certification test. The certified impactor may be used for a maximum of 20 impacts before re-certification (this limit does not apply to propulsion or guidance components). The impactor shall also be re-certified if more than one year has elapsed since the previous certification or if any impactor transducer output, in any impact, has exceeded the specified CAC.
- 5.4.1.6 The upper legform impactor shall be mounted and propelled as specified in paragraphs 3.1.1 and 3.2.
- 5.4.2 Test Procedure
- 5.4.2.1 The state of the vehicle or sub-system shall comply with the requirements of paragraphs 2.1 or 2.2 respectively. The stabilized temperature of the test apparatus and the vehicle or sub-system shall be $20^{\circ} \pm 4^{\circ}$ C.
- 5.4.2.2 Tests shall be made to the bonnet leading edge, between the 'corner reference points', defined in paragraph 2.4.3 of Annex I, to locations defined in paragraph 5.2.
- 5.4.2.3 The upper legform impactor shall be aligned such that the centre line of the propulsion system and the longitudinal axis of the impacting upper legform impactor are in the fore and aft vertical plane of the section of the vehicle to be tested. The tolerances to these directions are $\pm 2^{\circ}$. At the time of first contact the impactor centre line shall be coincident with the bonnet leading edge reference line with a ± 10 mm tolerance, (see Figure 2.4) and laterally with the selected impact location with a tolerance of ± 10 mm.
- 5.4.2.4 The required impact velocity, the direction of impact and the upper legform impactor mass shall be determined as specified in paragraph 5.4.2.6 and 5.4.2.7. The tolerance to the impact velocity is $\pm 5\%$ and the tolerance to the impact direction is $\pm 2^{\circ}$. The upper legform impactor mass should be measured to an accuracy of better than $\pm 1\%$, and if the measured value differs from the required value then the required velocity should be adjusted to compensate, as specified in par. 5.4.2.7.
- 5.4.2.5 Determination of Vehicle Shape:
- (1) The position of the bumper reference line shall be determined as defined in paragraph 2.2.1 of Annex I.
 - (2) The bonnet leading edge reference line shall be determined as defined in paragraph 2.3.1 of Annex I.

- (3) For the section of bonnet leading edge to be tested the bonnet leading edge height and the bumper lead shall be determined as defined in paragraphs 2.3.2 and 2.3.3 of Annex I.

5.4.2.6 Determine the required impact velocity and the direction of impact from Figures 2.5 and 2.6 with reference to the values of bonnet leading edge height and bumper lead determined in paragraph 5.4.2.5.

5.4.2.7 The total mass of the upper legform impactor includes those propulsion and guidance components which are effectively part of the impactor during the impact, including the extra weights.
Calculate the value of the upper legform impactor mass from

$$M = \frac{2E}{V^2} \quad \text{where } M = \text{Mass [kg]} \\ E = \text{Impact Energy [J]} \\ V = \text{Velocity [m/s]}$$

The required velocity shall be the value derived in paragraph 5.4.2.6 and the energy shall be derived from Figure 2.7 with reference to the values of bonnet leading edge height and bumper lead determined in paragraph 5.4.2.5.

To allow the use of standard increments of adjustable mass, the upper legform impactor mass may be adjusted from the calculated value by up to $\pm 5\%$, provided the required impact velocity is also changed using the above formula to maintain the same impactor kinetic energy.

5.4.2.8 Fit the required adjustable mass to give the calculated value of upper legform impactor mass determined in paragraph 5.4.2.7.

6. HEADFORM TO BONNET TOP TESTS

6.1 Purpose - to test for the requirements given in paragraph 5.4 of Annex I.

6.2 Headform impactor tests shall be to the bonnet top as defined in paragraph 2.4 of Annex I. Tests to the forward section of the bonnet top defined in paragraph 6.4.2.3 shall be with a child headform impactor defined in paragraph 6.4.1.1. Tests to the rearward section of the bonnet top defined in paragraph 6.4.2.4 shall be with an adult headform impactor, defined in paragraph 6.4.1.1. A minimum of nine tests shall be carried out with each headform impactor, three tests each to the middle and the outer thirds of the forward and rearward bonnet top sections, as described in paragraph 2.4.4 of Annex I, at positions judged to be the most likely to cause injury. Tests shall be to different types of structure, where these vary throughout the area to be assessed. The selected test points for the adult headform impactor shall be a minimum of 165 mm apart and a minimum of 82.5 mm inside the defined bonnet side reference lines. The selected test points for the child headform impactor shall be a minimum of 130 mm apart and a minimum of 65 mm inside the defined bonnet side reference lines. Whenever test areas are too small to permit minimum spacing between tests, less than nine tests may be performed. The positions tested by the laboratories shall be indicated in the test report.

- 6.3 Requirement - The bonnet top shall comply with the requirements of this Directive, if in the tests specified, the values of Head Performance Criteria (HPC), calculated in accordance with paragraph 2.5 of Annex I do not exceed the acceptance values given in paragraph 5.4 of Annex I.
- 6.4 Test Method
- 6.4.1 Test apparatus
- 6.4.1.1 The child and adult headform impactors shall be rigid spheres fitted with a rubber skin and shall comply with the additional specifications of figure 2.8 and 2.9 including the notes. Diameters shall be 150 ± 2 mm for the adult and 115 ± 2 mm for the child headform spheres respectively, as shown in Figures 2.8 and 2.9. The total impactor masses shall be 4.8 ± 0.1 kg for the adult and 2.5 ± 0.05 kg for the child headform impactor.
- 6.4.1.2 One triaxial (or three uniaxial) accelerometer shall be mounted in the centre of the sphere for both child and adult headform impactors.
- 6.4.1.3 The instrumentation response values CFC and CAC for the accelerometer shall be 1000 Hz and 500 g respectively as defined in ISO 6487: 1987.
- 6.4.1.4 The headform impactors shall meet the performance requirement specified in paragraphs 1.2 and 4 of Annex III, and shall be fitted with a rubber skin. The certified impactor may be used for a maximum of 20 impacts before re-certification. The impactor shall be re-certified if more than one year has elapsed since the previous certification or if the transducer output, in any impact, has exceeded the specified CAC.
- 6.4.1.5 The headform impactors shall be mounted, propelled and released as specified in paragraphs 3.1.2 and 3.2 of Annex II.
- 6.4.2 Test Procedure
- 6.4.2.1 The state of the vehicle or sub-system shall comply with the requirements of paragraphs 2.1 or 2.2 respectively. The stabilized temperature of the test apparatus and the vehicle or sub-system shall be $20^\circ \pm 4^\circ$ C.
- 6.4.2.2 Tests shall be made to the bonnet top within the boundaries as defined in paragraph 2.4 of Annex I, and as specified in paragraphs 6.2, 6.4.2.3 and 6.4.2.4.
- For tests to the windscreen lower frame the headform impactor shall not contact the windscreen glass before impacting the vehicle structure.
- 6.4.2.3 A child headform impactor as defined in paragraph 6.4.1 shall be used for tests to the forward section of the bonnet top, with the points of first contact lying between boundaries described by wrap around distances of 1000 mm and 1500 mm or by the lower edge of the windscreen as defined in paragraph 2.4 of Annex I. The direction of impact shall be as specified in paragraph 6.4.2.5 and the impact velocity as specified in paragraph 6.4.2.6.

- 6.4.2.4 An adult headform impactor as defined in paragraph 6.4.1 shall be used for tests to the rearward section of the bonnet top, with the points of first contact lying between boundaries described by wrap around distances of 1500 mm and 2100 mm or by the lower edge of the windscreen as defined in paragraph 2.4 of Annex I.
The direction of impact shall be as specified in paragraph 6.4.2.5 and the impact velocity as specified in paragraph 6.4.2.6.
- 6.4.2.5 The direction of impact shall be in the fore and aft vertical plane of the section of the vehicle to be tested. The tolerance for this direction is $\pm 2^\circ$. The direction of impact of tests to the bonnet top shall be downward and rearward, as if the vehicle were on the ground. The angle of impact for tests with the child headform impactor shall be $50^\circ \pm 2^\circ$ to the Ground Reference Level. For tests with the adult headform impactor the angle of impact shall be $65^\circ \pm 2^\circ$ to the Ground Reference Level.
- 6.4.2.6 At the time of first contact the centre line of the headform impactor shall be within a ± 10 mm tolerance to the impact location.
- 6.4.2.7 The impact velocity of the headform impactor when striking the bonnet top shall be 11.1 ± 0.5 m/s.

7. EQUIVALENT PROCEDURES

- 7.1 Alternative tests shall be permitted at the discretion of the Approval Authority provided equivalence can be demonstrated. A report shall be attached to the approval documentation describing the method used and the results obtained or the reasons for not carrying out the test.
- 7.2 Responsibility for demonstrating the equivalence of the alternative method shall rest with the manufacturer or their agent wishing to use such a method.

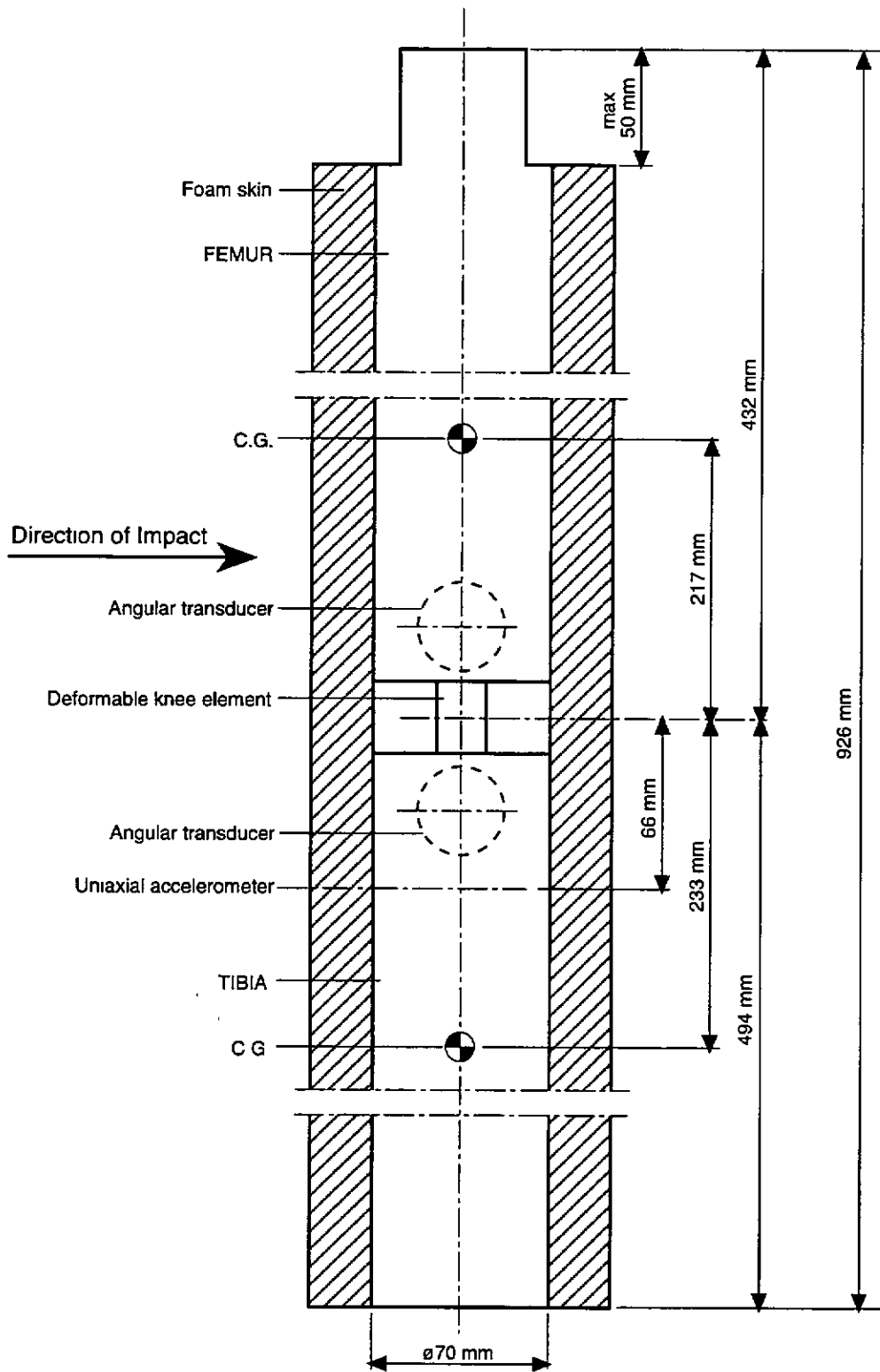

Figure 2.1 Legform impactor, with foam covering (dimensions in mm). See also notes.

Legform impactor - notes

1. The legform impactor shall be covered by a 25 mm thick Confor™ foam type CF-45 and a skin made of 6 mm thick neoprene.
2. The 'centre of the knee' is defined as the point about which the knee effectively bends. The 'femur' is defined as all components or parts of components (including flesh, skin covering and instrumentation) above the level of the centre of the knee. The 'tibia' is defined as all components or part of components (including flesh, skin covering and instrumentation) below the level of the centre knee. Note that the tibia as defined includes allowances for the mass etc. of the foot.
3. The total mass of the femur and tibia shall be 8.6 ± 0.1 kg and 4.8 ± 0.1 kg respectively, and the total mass of the legform shall be 13.4 ± 0.1 kg. The centre of gravity of the femur and tibia shall be 217 ± 10 mm and 233 ± 10 mm from the centre of the knee respectively. The moment of inertia of the femur and tibia, about a horizontal axis through the respective centre of gravity, shall be 0.127 ± 0.010 kgm² and 0.120 ± 0.010 kgm² respectively.
4. A uniaxial accelerometer shall be mounted on the non-impacted side of the tibia, 66 ± 5 mm below the knee joint centre, with its sensitive axis in the direction of impact.
5. The impactor shall be instrumented to measure the bending angle and the shearing displacement between femur and tibia.

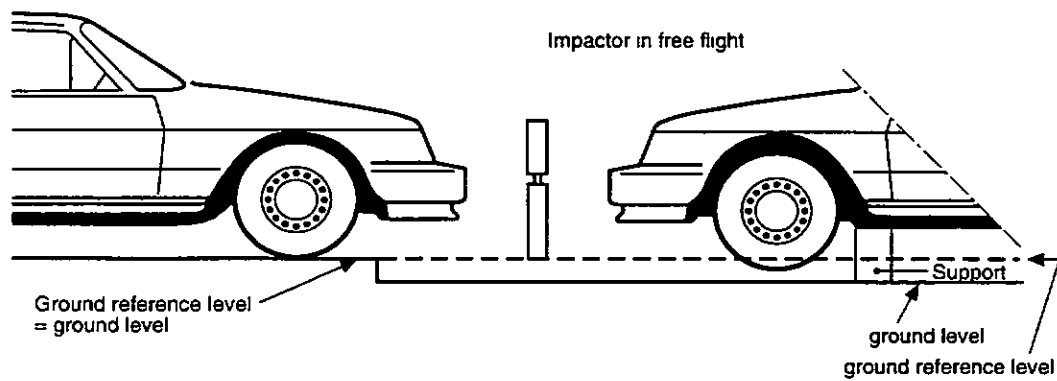

Figure 2.2 Legform to bumper tests for complete vehicle in normal ride attitude (left) and for complete vehicle or sub-system mounted on supports (right).

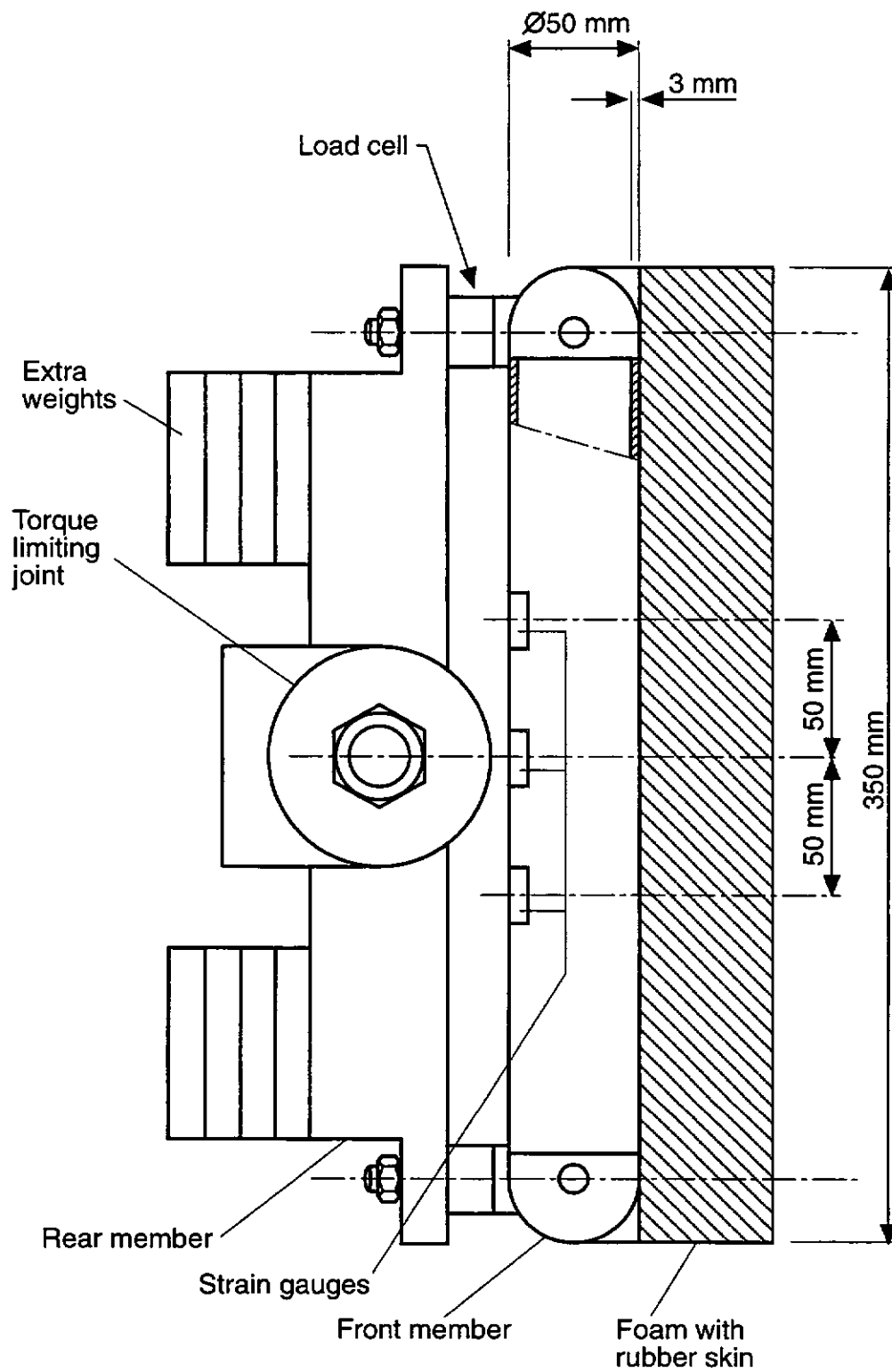

Figure 2.3 Upper legform impactor. See also notes.

Upper legform impactor - notes

1. The total mass of the upper legform impactor including those propulsion and guidance components which are effectively part of the impactor during the impact, excluding the extra weights, shall not be more than 9.5 kg.
2. The total mass of the front member and other components in front of the load cell assemblies, together with those parts of the load cell assemblies in front of the active elements, but excluding the foam and skin, shall be 1.95 ± 0.05 kg.
3. The foam shall be 2 sheets of 25 mm thick Confor™ foam type CF-45. The skin shall be a 1.5 mm thick fibre reinforced rubber sheet. The foam and rubber skin together shall weigh 0.8 ± 0.1 kg, and shall be folded back and attached to the sides of the rear member.
4. The front member shall be strain gauged to measure bending moments in three positions, as shown in Figure 2.3, each using a separate channel. The strain gauges are located on the impactor on the back of the front member. The two outer strain gauges are located 50 ± 1 mm from the impactor's symmetrical axis. The middle strain gauge is located on the symmetrical axis with a ± 1 mm tolerance.
5. The torque limiting joint shall be set so that the longitudinal axis of the front member is perpendicular to the axis of the guidance system, with a tolerance of $\pm 2^\circ$, with the joint friction torque set to a minimum of 650 Nm.
6. The centre of gravity of those parts of the impactor which are effectively forward of the torque limiting joint, including any weights fitted, shall lie on the longitudinal centre line of the impactor, with a tolerance of ± 10 mm.
7. The length between the load cell centrelines shall be 310 ± 1 mm and the front member diameter shall be 50 ± 1 mm.

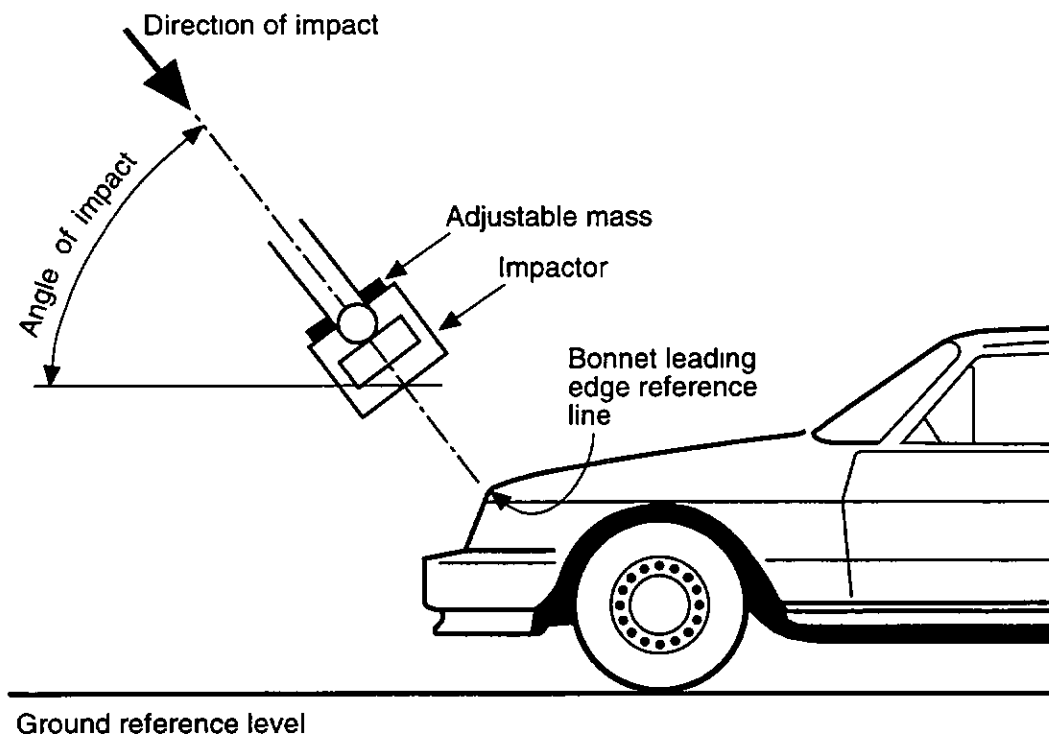
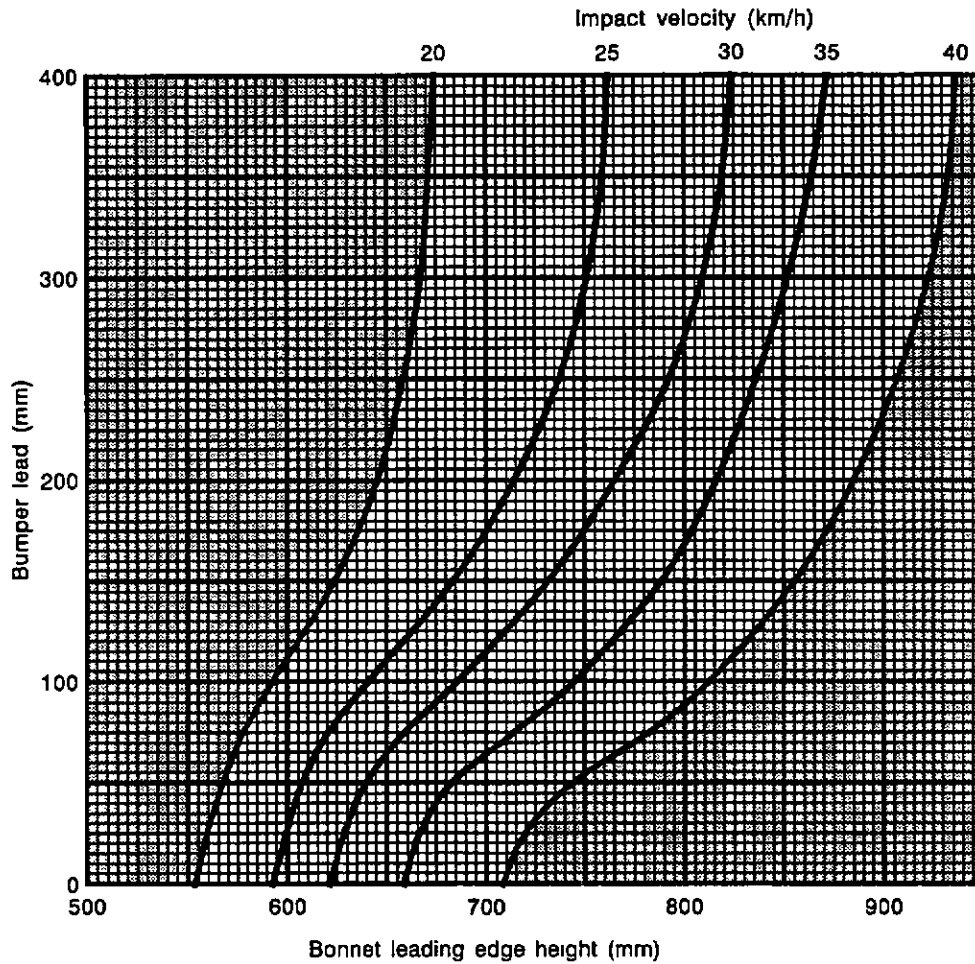

Figure 2.4 Upper legform to bonnet leading edge tests.



Notes:

1. Interpolate horizontally between curves.
2. With configurations below 20 km/h - test at 20 km/h.
3. With configurations above 40 km/h - test at 40 km/h.
4. With negative bumper leads - test as for zero bumper lead.
5. With bumper leads above 400 mm - test as for 400 mm.

Figure 2.5 Velocity of upper legform to bonnet leading edge tests with respect to vehicle shape.

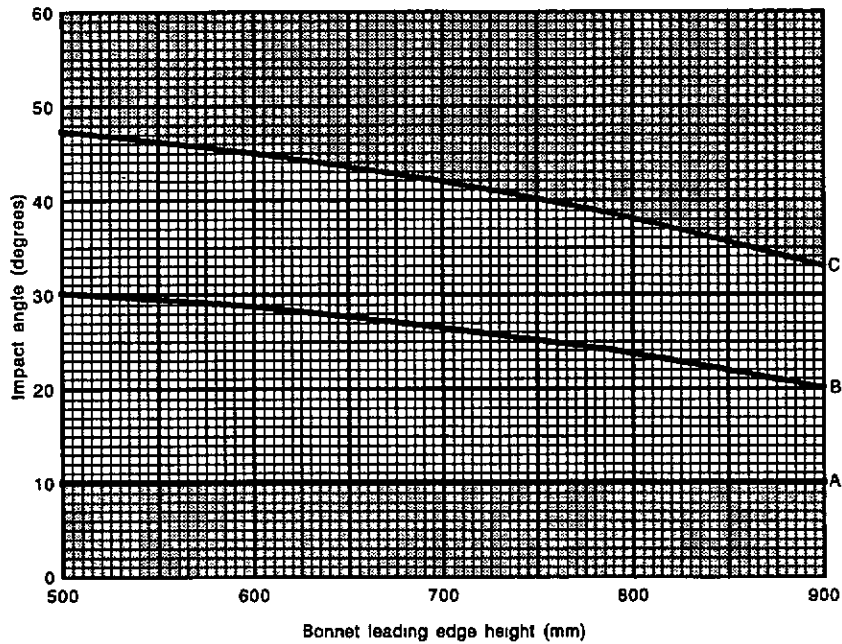

Key:-

- A ≤ 0 mm bumper lead
- B = 50 mm bumper lead
- C ≥ 150 mm bumper lead

Notes:

1. Interpolate vertically between curves.
2. With negative bumper leads - test as for zero bumper lead.
3. With bumper leads above 150 mm - test as for 150 mm.
4. With bonnet heights above 900 mm - test as for 900 mm.

Figure 2.6 Angle of upper legform to bonnet leading edge tests with respect to vehicle shape.

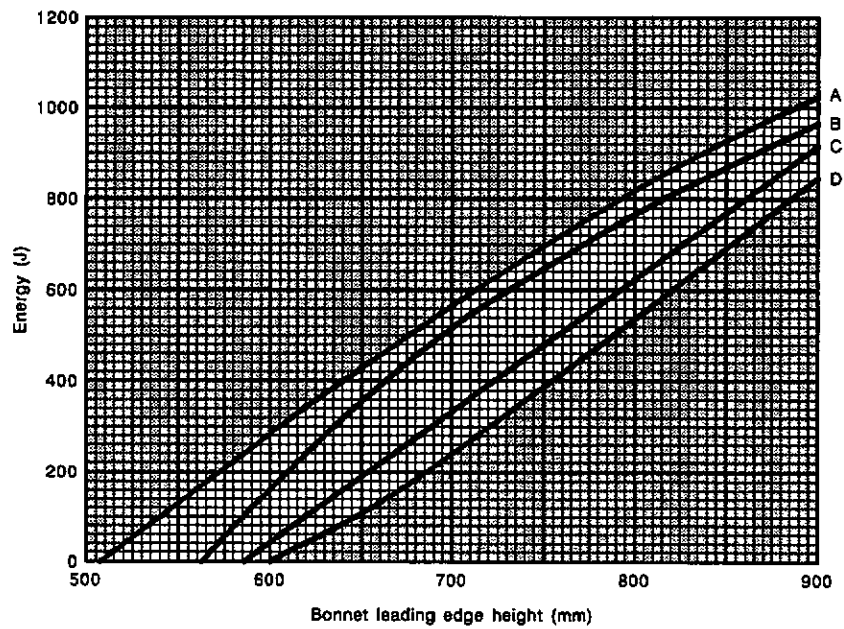

Key:-

- A \leq 0 mm bumper lead
- B = 100 mm bumper lead
- C = 225 mm bumper lead
- D \geq 350 mm bumper lead

Notes:

1. Interpolate vertically between curves.
2. With negative bumper leads - test as for zero bumper lead.
3. With bumper leads above 350 mm - test as for 350 mm.
4. With bonnet heights above 900 mm - test as for 900 mm.

Figure 2.7 Kinetic energy of upper legform to bonnet leading edge tests with respect to vehicle shape.

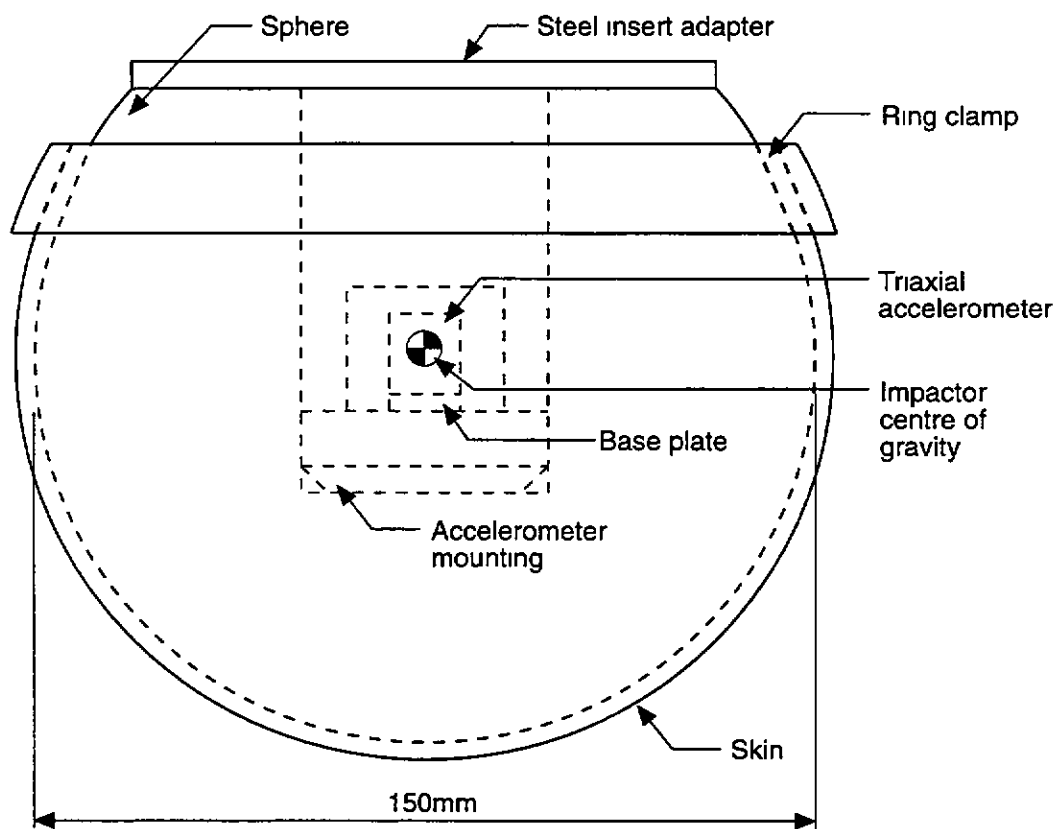

Figure 2.8 Adult headform impactor. See also notes.

Adult headform impactor - notes

1. The adult headform impactor is a sphere made of Phenolic Resin, with a suitable insert (e.g. steel) and of homogenous construction.
2. The sphere shall be covered with a 7.5 ± 0.1 mm thick rubber skin, which shall cover at least half of the sphere.
3. The centre of gravity of the adult headform impactor shall be located in the centre of the sphere with a tolerance of ± 10 mm.
4. A recess in the insert shall allow for mounting one triaxial or three uniaxial accelerometers within a tolerance of ± 10 mm to the centre of the sphere of the adult headform impactor.

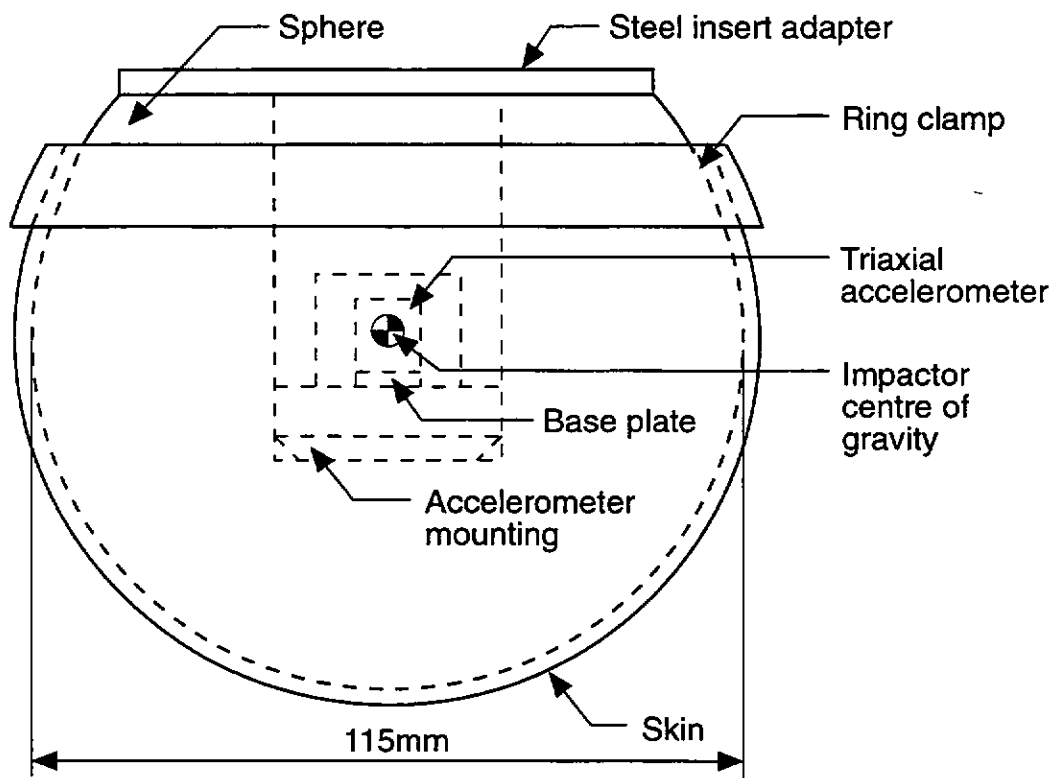

Figure 2.9 Child headform impactor. See also notes.

Child headform impactor - notes

1. The child headform impactor is a sphere made of Phenolic Resin, with a suitable insert (e.g. steel) and of homogenous construction.
2. The sphere shall be covered with a 7.5 ± 0.1 mm thick rubber skin, which shall cover at least half of the sphere.
3. The centre of gravity of the child headform impactor shall be located in the centre of the sphere with a tolerance of ± 10 mm.
4. A recess in the insert shall allow for mounting one triaxial or three uniaxial accelerometers within a tolerance of ± 10 mm to the centre of the sphere of the child headform impactor.

ANNEX III CERTIFICATION OF IMPACTORS

1. CERTIFICATION REQUIREMENTS

- 1.1 The impactors that are used in the three tests detailed in Annex II are required to comply with appropriate performance requirements.

The requirements for the legform impactor are specified in paragraph 2; the upper legform impactor requirements are specified in paragraph 3 and the adult and child headform impactor requirements are specified in paragraph 4.

- 1.2 The stabilized temperature of the impactor systems during certification shall be $20^{\circ} \pm 2^{\circ}$ C.

2. LEGFORM IMPACTOR CERTIFICATION

- 2.1 Static tests

- 2.1.1 The legform impactor shall meet the requirements specified in paragraph 2.1.2 when tested as specified in paragraph 2.1.4 and the legform impactor shall meet the requirements specified in paragraph 2.1.3 when tested as specified in paragraph 2.1.5.

For both tests the impactor shall have the intended orientation about its longitudinal axis, for the correct operation of its knee joint, with a tolerance of $\pm 2^{\circ}$.

- 2.1.2 When the legform impactor is loaded in bending in accordance with paragraph 2.1.4, the applied force/bending angle response shall be within the limits shown in Figure 3.1.

- 2.1.3 When the legform impactor is loaded in shearing in accordance with paragraph 2.1.5, the applied force/shearing displacement response shall be within the limits shown in Figure 3.2.

- 2.1.4 The legform impactor, without foam covering and skin, shall be mounted with the tibia firmly clamped to a fixed horizontal surface and a metal tube connected firmly to the femur, as shown in Figure 3.3.

A horizontal normal force shall be applied to the metal tube at a distance of 2.0 m from the centre of the knee joint and the resulting angle of knee deflection shall be recorded. The load shall be increased until the angle of deflection of the knee is in excess of 15° .

- 2.1.5 The legform impactor, without foam covering and skin, shall be mounted with the tibia firmly clamped to a fixed horizontal surface and a metal tube connected firmly to the femur and restrained at 2.0 m from the centre of the knee joint, as shown in Figure 3.4.

A horizontal normal force shall be applied to the femur at a distance of 50 mm from the centre of the knee joint and the resulting knee shearing displacement

shall be recorded. The load shall be increased until the shearing displacement of the knee is in excess of 6 mm.

2.2 Dynamic tests

2.2.1 The legform impactor shall meet the requirements specified in paragraph 2.2.2 when tested as specified in paragraph 2.2.4.

2.2.2 When the legform impactor is impacted against a deformable barrier, as specified in paragraph 2.2.4, the maximum upper tibia acceleration shall be not less than [] g and not more than [] g. The maximum bending angle shall be not less than [] and not more than []. The maximum shearing displacement shall be not less than [] mm and not more than [] mm.

2.2.3 The instrumentation response values CFC and CAC shall be 180 Hz and 20° respectively for the angular transducers and 180 Hz and 500 g for the accelerometer, as defined in ISO 6487: 1987.

2.2.4 The legform impactor, including foam covering and skin, shall be attached to a pendulum arm as shown in Figure 3.5 so that the impactor shall have the intended orientation about its vertical axis, for the correct operation of its knee joint with a tolerance of $\pm 2^\circ$. The centre of a Honeycomb barrier (Hexcell 1.8 lbs/cub.ft), which is 165 mm long, 105 mm wide and 50 mm thick, shall be placed 1775 mm below the rotation axis of the pendulum arm. The Honeycomb shall be fixed to a rigid support which is located 75 mm from a vertical plane through the rotation axis of the pendulum arm (see Figure 3.5). A 0.8 mm thick, 170 mm long, 110 mm wide, aluminium plate shall be placed in front of the Honeycomb.

The pendulum should have a mass of 15.4 ± 0.1 kg and a length of 1258 ± 10 mm from the rotation axis to the end of the arm. The moment of inertia around an axis through the centre of gravity aligned with the rotation axis is 1.5 ± 0.1 kgm². The centre of gravity is 556 ± 10 mm from the rotation axis.

The legform impactor shall be released from a specific drop height to obtain an impact velocity of 6.5 ± 0.1 m/s, measured at a distance of 1775 mm from the rotation axis of the pendulum arm. The centre of the Honeycomb barrier shall impact the legform impactor at a distance of 330 ± 5 mm from the bottom.

3. UPPER LEGFORM IMPACTOR CERTIFICATION

3.1 The upper legform impactor shall meet the requirement specified in paragraph 3.2 when tested as specified in paragraph 3.3.

3.2 Requirements

3.2.1 When the upper legform impactor is propelled into a stationary cylindrical pendulum the peak force measured in each load cell shall be not less 1.2 kN and not more than 1.55 kN and the difference between the peak forces measured in the top and bottom load cells shall not be more than 0.1 kN. Also, the peak bending moment measured by the strain gauges shall not be less than 190 Nm and not more than 250 Nm on the centre position and not less than 160 Nm and not more than 220 Nm for the outer positions. The difference between the upper and lower peak bending moments shall not be more than 20 Nm.

For all these values the readings used shall be from the initial impact with the pendulum and not from the arresting phase. Any system used to arrest the impactor or pendulum shall be so arranged that the arresting phase does not overlap in time with the initial impact. The arresting system shall not cause the transducer outputs to exceed the specified CAC.

3.2.2 The instrumentation response values CFC shall be 180 Hz and CAC shall be 10 kN for force transducers and 1000 Nm for the bending moment measurements, as defined in ISO 6487: 1987.

3.3 Test procedure

3.3.1 The upper legform impactor shall be mounted to the propulsion and guidance system, by a torque limiting joint. The torque limiting joint shall be set so that the longitudinal axis of the front member is perpendicular to the axis of the guidance system, with a tolerance of $\pm 2^\circ$, with the joint friction torque set to a minimum of 650 Nm. The guidance system shall be fitted with low friction guides that allow the impactor to move only in the specified direction of impact, when in contact with the pendulum.

3.3.2 The impactor mass shall be adjusted to give a mass of 12 ± 0.1 kg, this mass includes those propulsion and guidance components which are effectively part of the impactor during impact.

3.3.3 The centre of gravity of those parts of the impactor which are effectively forward of the torque limiting joint, including the extra weights fitted, shall lie on the longitudinal centreline of the impactor, with a tolerance of ± 10 mm.

3.3.4 The impactor shall be certified with previously unused foam.

3.3.5 The impactor foam shall not be excessively handled or deformed before, during or after fitting.

- 3.3.6 The impactor with the front member vertical shall be propelled horizontally at a velocity of 8.0 ± 0.1 m/s into the stationary pendulum as shown in Figure 3.6.
- 3.3.7 The pendulum tube shall have a mass of 3 ± 0.03 kg and an outside diameter of 150 ± 0.5 mm. The centre of gravity of the pendulum tube shall be on its longitudinal axis 75 ± 1.0 mm from the pendulum bottom. Total pendulum tube length shall be 275 ± 25 mm. It shall be suspended on two wire ropes of 1.6 ± 0.1 mm diameter and of 2.0 m minimum length. The surface of the pendulum shall be clean and dry. The pendulum tube shall be positioned so that the longitudinal axis of the cylinder is perpendicular to the front member (i.e. level) and to the direction of impactor motion, with the centre of the pendulum tube aligned with the centre of the impactor front member.

4. HEADFORM IMPACTOR CERTIFICATION

- 4.1 The child and the adult headform impactors shall meet the requirements specified in paragraph 4.2 when tested as specified in paragraph 4.3.
- 4.2 Requirements
- 4.2.1 When the child headform impactor is dropped from a height of 250 mm in accordance with paragraph 4.3 the peak resultant accelerations measured by one triaxial [or three uniaxial] accelerometers in the headform shall be not less than 210 g and not more than 260 g. The resultant acceleration time curve shall be uni-modal.
- 4.2.2 When the adult headform impactor is dropped from a height of 376 mm in accordance with paragraph 4.3 the peak resultant accelerations measured by one triaxial [or three uniaxial] accelerometers in the headform shall be not less than 225 g and not more than 275 g. The resultant acceleration time curve shall be uni-modal.
- 4.2.3 The instrumentation response values CFC and CAC for the accelerometer shall be 1000 Hz and 500 g respectively as defined in ISO 6487: 1987.
- 4.3 Test procedure
- 4.3.1 The headform impactor shall be suspended to a drop rig as shown in Figure 3.7.
- 4.3.2 The headform impactors shall be dropped from the specified heights by means that ensures instant release onto a rigid supported flat horizontal steel plate, 50 mm thick and 600 mm square which has a clean dry surface and a surface finish of between 0.2 and 2.0 micrometers.
- 4.3.3 The adult headform impactor shall be dropped with the rear face at an angle of 65° with the vertical and the child headform impactor shall be dropped with the rear face at an angle of 50° with the vertical, as specified in Figure 3.7. The

suspension of the headform impactor shall be such that the impactor does not rotate during the free fall.

- 4.3.4 The drop test shall be performed three times, with the head impactor rotated by 120° along its symmetry axis after each test.

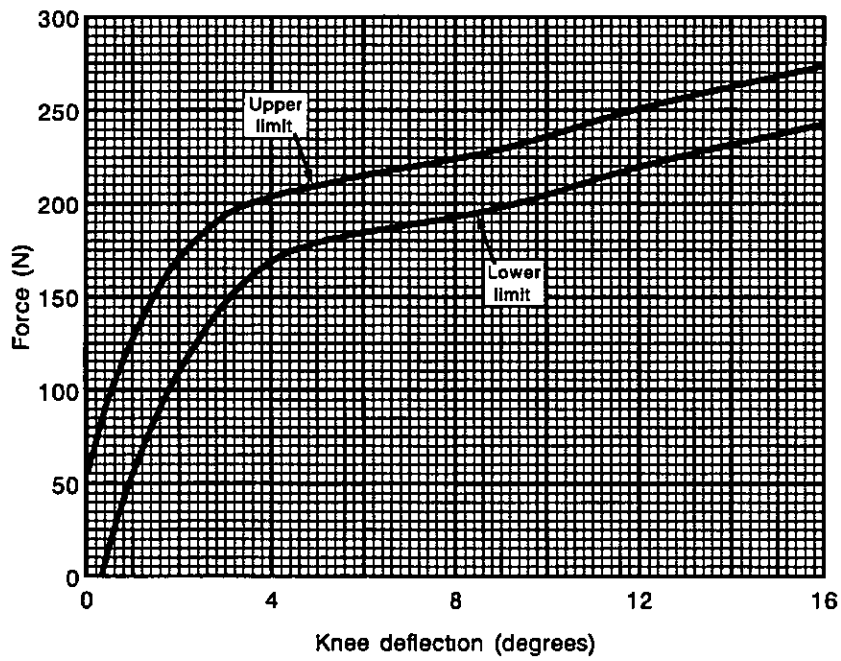

Figure 3.1 Force vs. angle requirement in static legform impactor bending test.

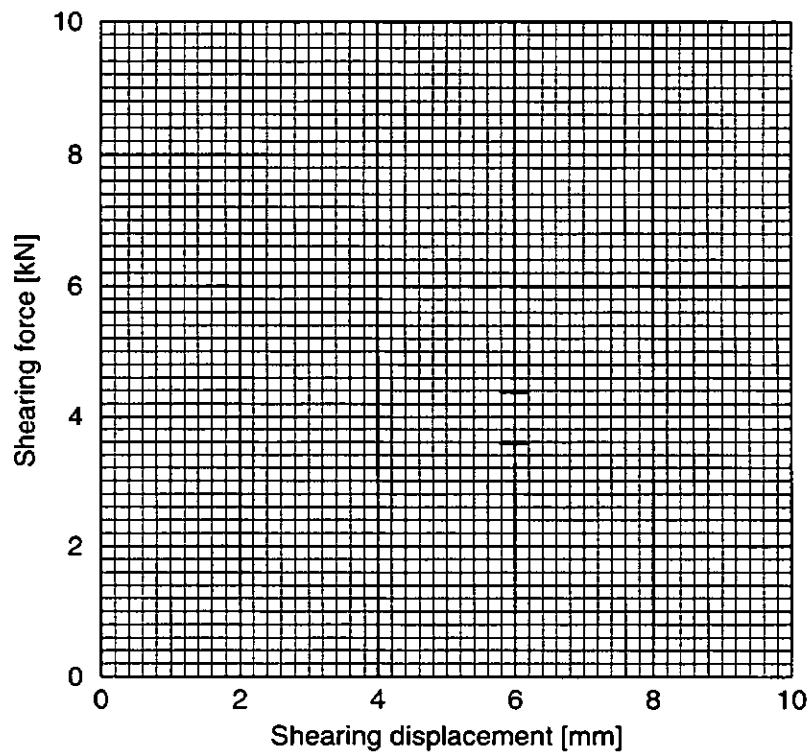

Figure 3.2 Force vs. displacement requirement in static legform impactor shearing test.

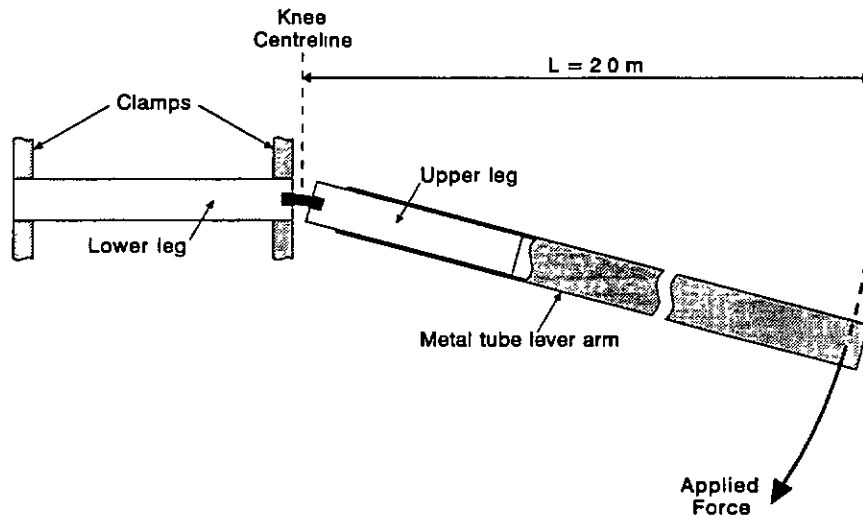

Figure 3.3 Test set-up for static legform impactor bending test.

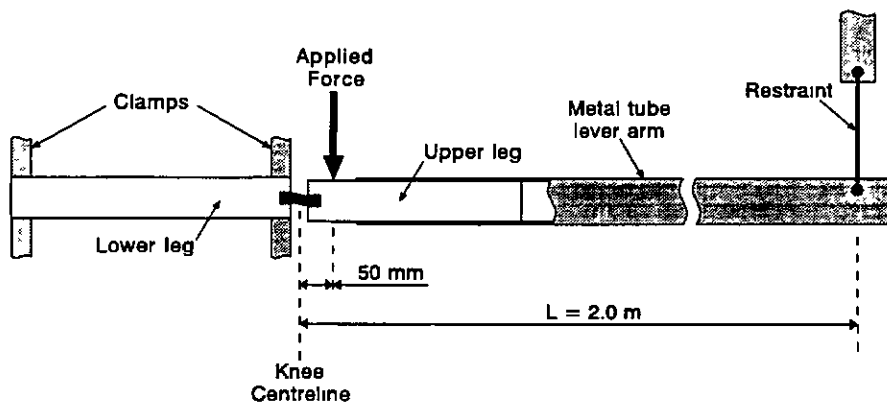

Figure 3.4 Test set-up for static legform impactor shearing test.

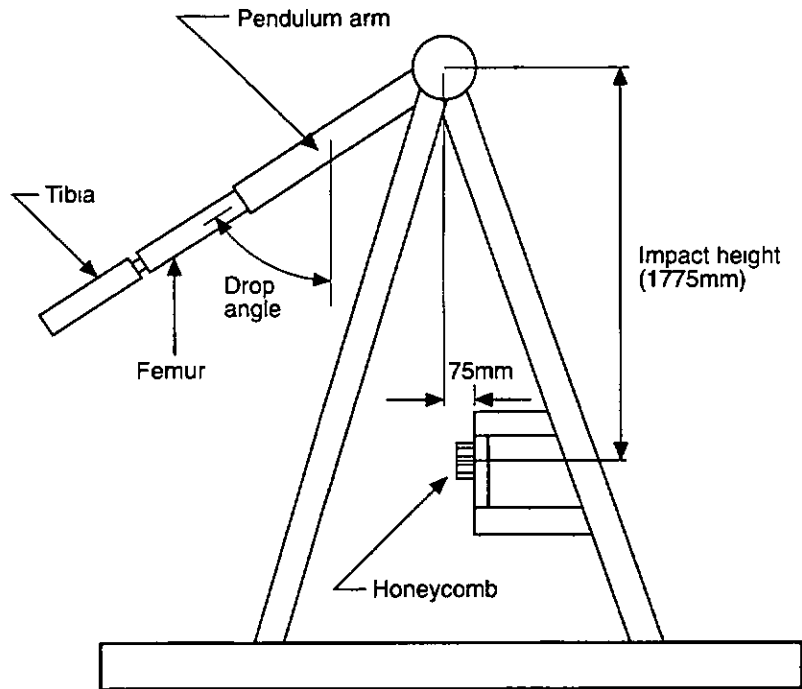

Figure 3.5 Test set-up for dynamic legform impactor certification test.

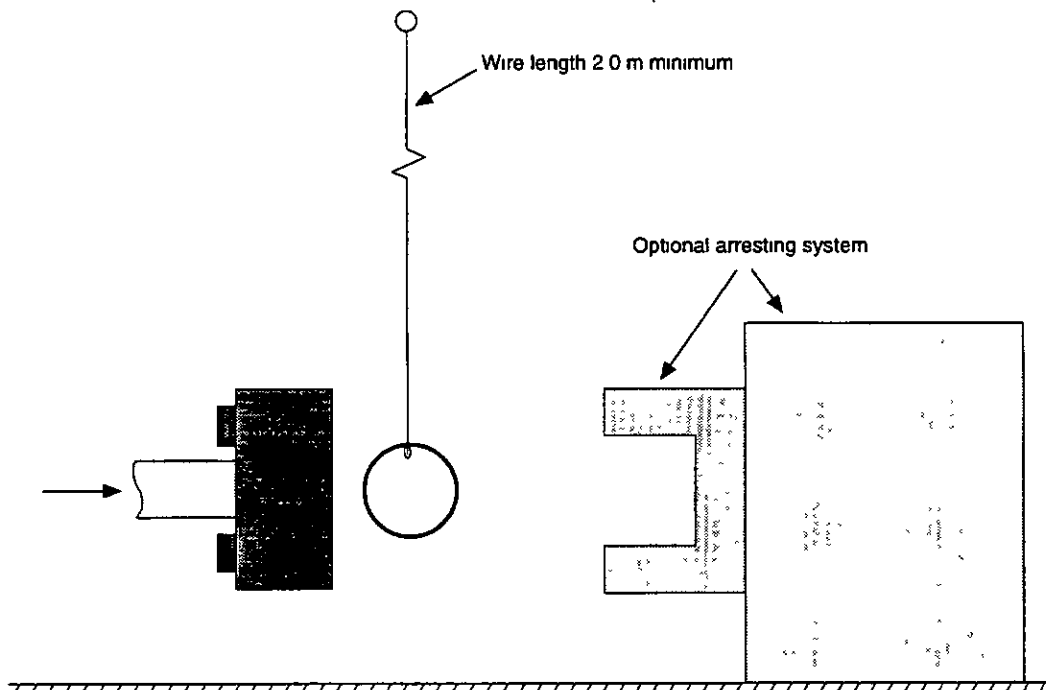

Figure 3.6 Test set-up for dynamic upper legform impactor certification test.

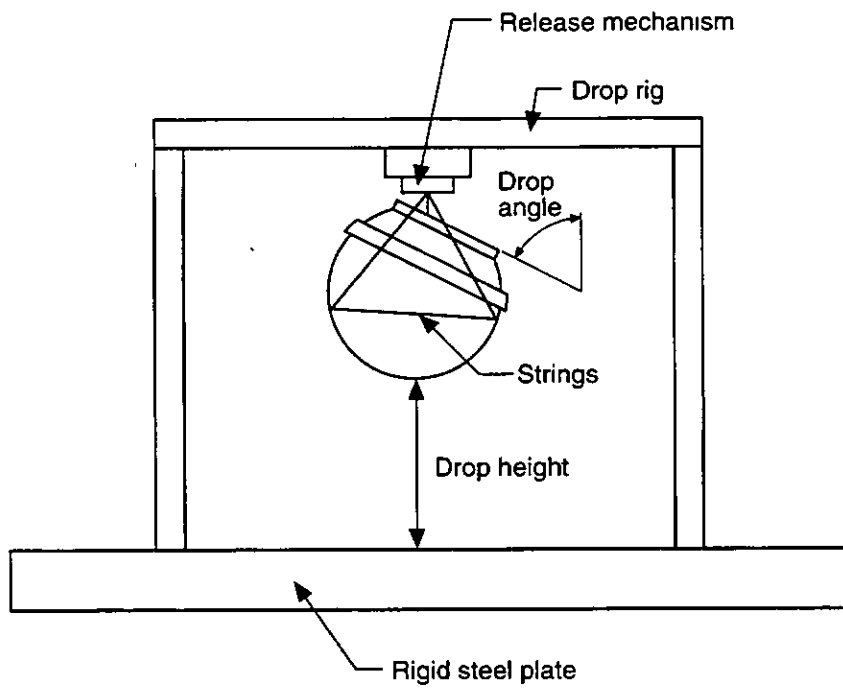

Figure 3.7 Test set-up for dynamic headform impactor certification test.

ANNEX IV

ANNEX OF THE EC TYPE-APPROVAL CERTIFICATE FOR A VEHICLE TYPE WITH REGARD TO THE BEHAVIOUR OF THE FRONTAL SURFACES IN THE EVENT OF AN IMPACT WITH A VULNERABLE ROAD USER.

(Article 4(2) and 10 of Council directive 70/156/EEC of 6 February 1970 on the approximation of the laws of the Member States relating to the type-approval of motor vehicles and their trailers).

Name of Administration _____

EC Type-approval number: _____

1. Trade name or mark of the motor vehicle

2. Vehicle type _____

3. Manufacturer's name and address _____

4. If applicable, name and address of the manufacturer's representative

5. Brief description of the frontal surfaces, items beneath the frontal surfaces and the components of the vehicle contributing to the protection of the vulnerable road user against the vehicle in the event of impact

6. Weight of the vehicle during the test
front axle _____
rear axle _____
Total: _____

7. (a) Reference height of bumper _____
 (b) Bonnet leading edge height _____
 (If undefinable mark ND)
 (c) Bumper lead _____
 (If undefinable mark ND).
8. (a) Maximum test values measured during the legform to bumper tests.
- (i) Knee bending angle _____
 (ii) Knee shearing displacement _____
 (iii) Tibia acceleration _____
- (b) Maximum test values measured during the upper legform to bonnet leading edge tests.
- (i) Force (sum) _____
 (ii) Bending moment (lower) _____
 (iii) Bending moment (centre) _____
 (iv) Bending moment (upper) _____
- (c) Maximum test values measured during the headform to bonnet top tests.
- (i) HPC from child headform tests
 to front of bonnet top _____
- (ii) HPC from adult headform tests
 to rear of bonnet top _____
9. Vehicle submitted for approval on _____
10. Technical service responsible for conducting approval tests _____
11. Date of report issued by the service _____
12. Number of report issued by that service _____
13. Approval granted/refused */
14. Place _____

15. Date _____

16. Signature _____

17. The following documents, bearing the approval number shown above, are annexed to this communication:

_____ drawings, diagrams and plans of the frontal surfaces and components beneath and the locations of the test positions.

*/ Strike out what does not apply