

EEVC/CEVE



European Experimental Vehicles Committee

EEVC Working Group 10 Report

**EEVC test methods to evaluate pedestrian protection afforded by
passenger cars**

15th ESV Conference. Melbourne, Australia, May 1996.

EEVC TEST METHODS TO EVALUATE PEDESTRIAN PROTECTION AFFORDED BY PASSENGERS CARS

E.G. Janssen

TNO Crash-Safety Research Centre

The Netherlands

On behalf of EEVC WG10

Paper Number 96-S7-W-17

ABSTRACT

In 1987 the European Experimental Vehicles Committee has set up Working Group 10 with the task to improve an existing proposal for an EC Directive with respect to pedestrian protection and to coordinate the necessary research. This Working Group finalized its activities in 1994.

This paper gives a general description and background information of the test methods developed by EEVC WG10 for assessing the protection afforded to pedestrians by the fronts of cars in an accident. The test methods are based on three sub-system tests, essentially to the bumper, bonnet leading edge and bonnet top surface. Each of the test conditions are generally based on a car to pedestrian impact velocity of 40 km/h but for the assessment of the leading edge of the bonnet, the test conditions are adjusted to compensate for the influence of vehicle shape. The acceptance levels for the tests are based on the characteristics of the weaker sections of the adult population including the aged, who have been shown to be the most susceptible to injury. The test methods are considered to be appropriate of children, but a separate child head impact test has been included to assess their particular requirements.

INTRODUCTION

In most European countries, unprotected road users like pedestrians account for a significant proportion of the road accident casualties. This was recognized by the European Experimental Vehicles Committee and several studies in this field were performed by Working Groups of EEVC [1,2,3]. Based on this research various recommendations for the front structure design of passenger cars were developed. Moreover, test methods and regulations have been proposed to assess pedestrian protection.

In the Spring of 1987 one of these proposals was discussed by the EEC ad-hoc working group 'Erga Safety' [4] It was concluded that the basis of the proposal was promising however, additional research was needed to fill up some gaps. The European Experimental Vehicles Committee was asked to coordinate this research and at

the end of 1987 EEVC Working Group 10 was set up

The mandate of this group was 'to determine test methods and acceptance levels for assessing the protection afforded to pedestrians by the fronts of cars in an accident. The test methods should be based on sub-system tests, essentially to the bumper, bonnet leading edge and bonnet top surface. The bumper test should include the air dam; the bonnet leading edge test should include the headlight surround and the leading edge of the wings, the test to the bonnet top should include the scuttle, the lower edge of the windscreen frame and the top of the wings. Test methods should be considered that evaluate the performance of each part of the vehicle structure with respect to both child and adult pedestrians, at car to pedestrian impact speeds of 40 km/h. The different impact characteristics associated with changes in the general shape of the car front should be allowed for by variations in the test conditions (e.g. impact mass and velocity, direction of impact)'.

Work programme

EEVC WG10 started its activities in January 1988. Both automobile industry and research institutes were represented in the working group. A programme was set-up intended to develop the required test methods as described by the mandate

The studies necessary to develop test methods have already been presented in a first report of EEVC WG10, presented to the 12th ESV Conference in 1989 [5]. These development studies included full scale dummy tests, cadaver tests, accident reconstructions, analysis of accident data and computer simulations. Furthermore the developed test proposals had to be tested against representative cars of current designs to determine the feasibility of the proposals. The compatibility with existing regulations, other safety features and basic operational requirements for cars was assessed. Figure 1 shows the work programme.

These studies were performed in 1989/1990 by a European consortium acting under contract to the European Commission and under the auspices of EEVC Working Group 10. The consortium consisted of BAST, INRETS, LAB/APR, TNO and TRL.

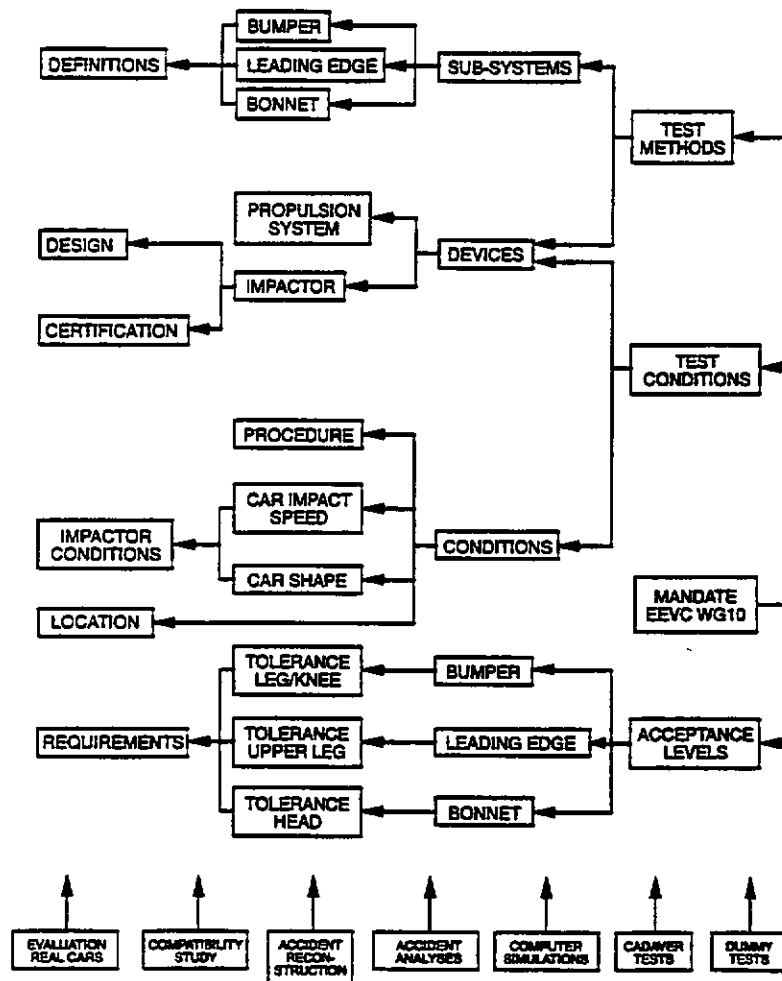

Figure 1. Mandate and work of EEVC Working Group 10.

The studies were completed in June 1991 and were summarized individually in technical reports [6-11]. The summary report [12] includes an Annex called "Frontal surfaces in the event of impact with a vulnerable road user - proposal for test methods". Based on this document, EEC/DGIII has drafted an extension to the existing Council Directive 74/483/EEC ("external projections") for inclusion of the EEVC sub-system test methods for pedestrian safety [13]. This work was also summarized in a second EEVC WG10 report, presented to the 13th ESV Conference in 1991 [14].

The EEVC Main Committee decided to extend the mandate of WG10 in order 'to consider what work would be necessary to support the results obtained from the EC study and to finalize the work programme'. WG10 restarted at the end of 1991 and since then the proposed

test methods, including sub-system impactors, have been evaluated thoroughly.

The members and organisations involved in the WG10 activities during the period 1991/1994 are presented in Appendix I.

The third and final report of EEVC WG10 [15] focused especially on the changes and improvements with respect to the previous version of the proposed test methods, as described in [12] and [14]. The Annex "Frontal surfaces in the event of impact with a vulnerable road user - proposal for test methods" was up-dated. Also general background information was given and choices explained. The current paper summarizes this work. Activities performed by the former members of WG10 since the end of 1994, will be presented as well.

TEST METHODS

In this section changes and improvements with respect to the previous version of the proposed test methods, as described in [12] and [14], will be presented. Also general background information will be given and choices that were made will be explained

General

Three sub-system tests are prescribed; legform to bumper, upper legform to bonnet leading edge and headform to bonnet top. The outer car structure representing these test areas is described in the test method. Attachments to these structures, for instance license plates, are also subject of these definitions and should be tested as such.

The bonnet top is divided in two areas, a forward area for a child headform impact and a rearward area (i.e. close to the windscreen) for an adult headform impact. Wrap around distances of 1000-1500 mm and 1500-2100 mm are defined for the boundaries of these two bonnet top test areas. The windscreen and A-pillars were not part of the mandate of WG10 and therefore not included as test area (the lower windscreen frame however is included).

The width of each test area is divided in 3 equal parts; a left and right outer part and a middle part. The side of the test area's is also defined by means of the 'corners' of the bumper and the leading-edge, and the 'side' of the bonnet top.

For vehicles with a special shape, exclusions are included in the test methods. For instance no headform test should be performed if the lower windscreen frame is located forward of the 1000 mm wrap around distance. No upper legform test needs to be performed if the determined kinetic energy of impact is 200 J or less, which can occur if the bonnet leading edge is located low and the bumper protrusion (i.e. bumper lead) is relatively large. If the bumper is located high and close to the bonnet leading edge, an upper legform to bumper test rather than to the bonnet leading edge is possible.

A minimum of three legform to bumper tests should be performed, one on each of the three bumper parts. A minimum of three upper legform to bonnet leading edge tests should be performed, one on each of the three bonnet leading edge parts. A minimum of nine tests should be performed with the child headform impactor, three tests each on the three forward bonnet top parts. A minimum of nine tests should be performed with the adult headform impactor, three tests each on the three rearward

bonnet top parts. Table 1 summarizes the total number of tests per test area. The impact location should be on a 'position most likely to cause injury' in order to assess the injury risk for pedestrians. This position should be specified by the authorities after examining the vehicle and drawings supplied.

The tests should be performed on different types of the vehicle structure, which means that it is not necessary to perform a test on a similar (read: symmetrical) construction in another part of the test area, even though this would be a 'high-injury-risk' location (e.g. bumper attachment in left and in right outer part of bumper test area).

Furthermore, the distance between different tests in one test area should be equal or larger than the diameter of the impactor used. This means for instance that the distance between the impact location of the test on the left outer part of the bumper and the impact location of the test on the middle part of the bumper should be at least 132 mm (i.e. diameter of legform impactor).

The distance between the impact location and the side of the vehicle should be equal to or more than the half diameter of the impactor used, to avoid a glance-off impact. For tests to the windscreen lower frame, contact of the headform impactor with the glass is not allowed before impacting the vehicle structure.

The constraints indicated above could lead to fewer impacts than described in Table 1, for instance if the adult bonnet top area is very small.

The vehicle or sub-system of the vehicle should be positioned such that it represents an impact between the vehicle, loaded with two occupants, and a pedestrian at an impact speed of 40 km/h. Brake diving is not simulated, because the car may not be braking at impact and many modern suspension systems are designed to reduce or eliminate brake dive. The suspension should be set for a driving speed of 40 km/h in normal running conditions, specified by the manufacturer, especially for vehicles with an active suspension or a device for automatic levelling.

In the legform to bumper test the vehicle or sub-system may be raised to avoid contact of the legform with the ground (see Figure 2). Computer simulations showed that foot to ground friction appears to have only a minor influence on the loads generated in the leg during an impact. This shows that foot to ground friction forces may be omitted from a bumper sub-system test [14].

If the propulsion system used can not achieve the required impact angles necessary for the upper legform to bonnet leading edge test or for the headform to bonnet top test, the rear end of the vehicle may be raised to obtain

the correct impact angle. However, this should not influence the performance of the vehicle (for instance by translation or rotation of the engine, creating additional space between engine and bonnet).

Table 1.
Total number of tests per test area

| TEST AREA | left outer part | middle part | right outer part | total |
|--------------------|-----------------|-------------|------------------|-------|
| bumper | 1 | 1 | 1 | 3 |
| leading edge | 1 | 1 | 1 | 3 |
| bonnet top - child | 3 | 3 | 3 | 9 |
| bonnet top - adult | 3 | 3 | 3 | 9 |
| total | 8 | 8 | 8 | 24 |

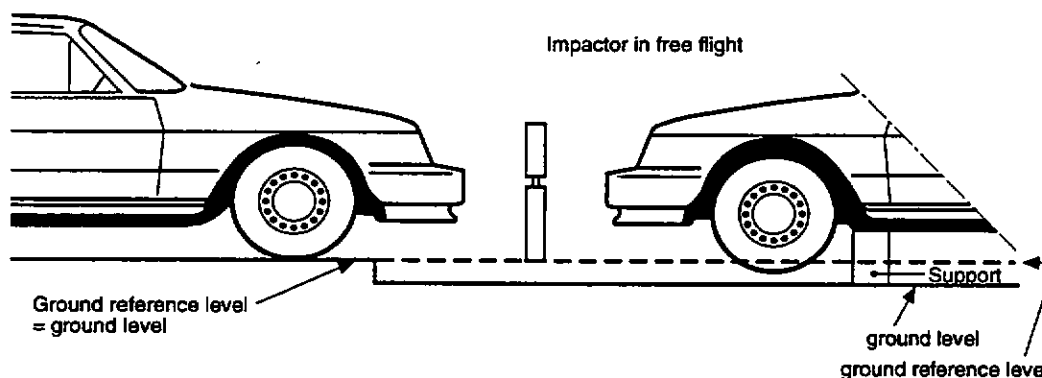

Figure 2. Legform to bumper test for complete vehicle in normal ride attitude (left) and for complete vehicle or subsystem mounted on supports (right).

It is possible that the vehicle to be assessed incorporates special devices designed to protect vulnerable road users, for instance a bonnet top which is lifted when the leading edge is impacted by the pedestrian. These (dynamic) systems should be active during the appropriate test. If they are activated in real accidents by a mechanism outside the considered test area (e.g. bonnet lifting is activated by sensor in bumper), they should be activated correctly during or before the test by an external trigger or manually. It is the responsibility of the applicant for approval to show that the device is activated (fast

enough) in a real accident.

The type of propulsion system is not prescribed, however free flight impacts at 40 km/h with masses between 2.5 kg and 13.5 kg should be possible. The upper legform impactor should be mounted to the propulsion system by a torque limiting joint, to prevent damage to the system, and should be guided throughout the impact. This test requires impacts at 20 to 40 km/h at effective impactor masses (including guidance components) of 9.5 to 17.7 kg.

Legform to bumper test

The original impactor that has been developed by INRETS for the bumper sub-system test was chosen to represent an adult leg being impacted from the side. Accident studies have shown that in accidents at speeds up to 40 km/h, adults and particularly the aged, seem to be more at risk than children to leg injury that may result in permanent disability [14].

Development of test method and impactor - Since the extension of the WG10 mandate, a lot of effort has been spent in the evaluation and improvement of the legform impactor [16]. Computer model simulations showed good results of the leg-model when compared with a complete dummy-model, if the bumper impact occurs below the knee level. With impacts above the knee level the leg-model showed somewhat lower responses [17]. It is felt that the test procedure allows for evaluation of car bumpers at 500 mm above ground level or below (if the bumper is located at 600 mm from the ground level, the upper leg test procedure applies)

The legform impactor has been used by INRETS in several tests with different passenger cars. These tests did not show any important problems concerning durability and repeatability. Tests on the same car with different bumper heights showed the sensitivity of the test method and impactor design to this parameter which is directly related to the risk of knee injuries [16]. Large differences in knee bending angle and knee shearing displacement were also found when the bumper is impacted in the middle (far from the bumper attachment) or in front of the bumper fixation, which is a much stiffer area.

TRL [18] has evaluated the test procedure and concluded that the prescribed procedure was clear and easy to follow. It was stated that the number of tests required, combined with the selection of points most likely to cause injury, gives a reasonable coverage of the bumper. Coefficients of variation for a test series on a simulated vehicle were 4% for bending, 9% for shear and 4% for acceleration. It was concluded that the impactor design has a robust appearance. Several recommendations were given to further improve the impactor design and were included in the latest version.

BASt [19] performed tests according to the EEVC method, using a different propulsion system to INRETS. BASt concluded that the definitions and corresponding measurements on the car were simple. The durability of the impactor was good. A statement on repeatability of the test method could not be given, but it was found that it is not easy to keep inside the tolerances for impact height and vertical impact angle. However, BASt used a free

flight distance of 1 m for the impactor, as described in earlier versions of the test method, while no minimum distance is prescribed in the latest version

The dimensions, masses and moment of inertia specifications of the legform impactor have been improved and are based now on measurements from Robbins for a 50th percentile male [20]. A flesh-simulating foam has been selected ('Confor-foam') and in order to improve repeatability a cylindrical shape has been defined for this foam. The instrumentation has been improved; the angles between upper and lower leg are measured directly now, rather than by a non-linear cam mechanism. The knee protection criteria, which are bending angle and shearing displacement, are calculated from these measured angles. A calculation method has been defined by WG10.

A lot of effort has been spent in the optimization of the characteristics of the deformable elements to control the lateral bending and shearing motion of the knee joint. WG10 considered also an alternative TRL knee design, in which the shearing is controlled by a leaf spring. The specifications of the legform are also fulfilled by this second design. Evaluation of the prototype design has been performed by BASt [21] and TNO [22]. BASt concluded that the TRL legform impactor showed satisfactory results and meets the requirements of an acceptable test device. However, they observed oscillations in the system, that should be damped by improvements to the prototype. TNO concluded that the repeatability was good. Oscillations in the system were also found by TNO and were further analyzed using a MADYMO mathematical model of the legform. Improvements have been proposed

Dynamic and static certification procedures have been developed for the legform impactor.

Impactor - The legform is 926 mm long and weighs 13.4 kg. It consists of two foam and skin covered rigid segments (see Figure 3) representing the lower leg (tibia and foot) and upper leg (femur) of an adult, connected by a simulated knee joint that will rotate and translate laterally. The motion of the knee joint is resisted by deformable elements, which are replaced after each test.

The legform is instrumented by angular transducers to measure the relative position of femur and tibia to each other. Additionally, an accelerometer is fitted to the non-impact side of the tibia, close to the knee joint (see Figure 3).

Test method - The impact velocity of the 13.4 kg legform impactor when striking the bumper in 'free flight' is equal to the vehicle/pedestrian impact speed (40 km/h or 11.1 m/s). The impact direction is parallel to the

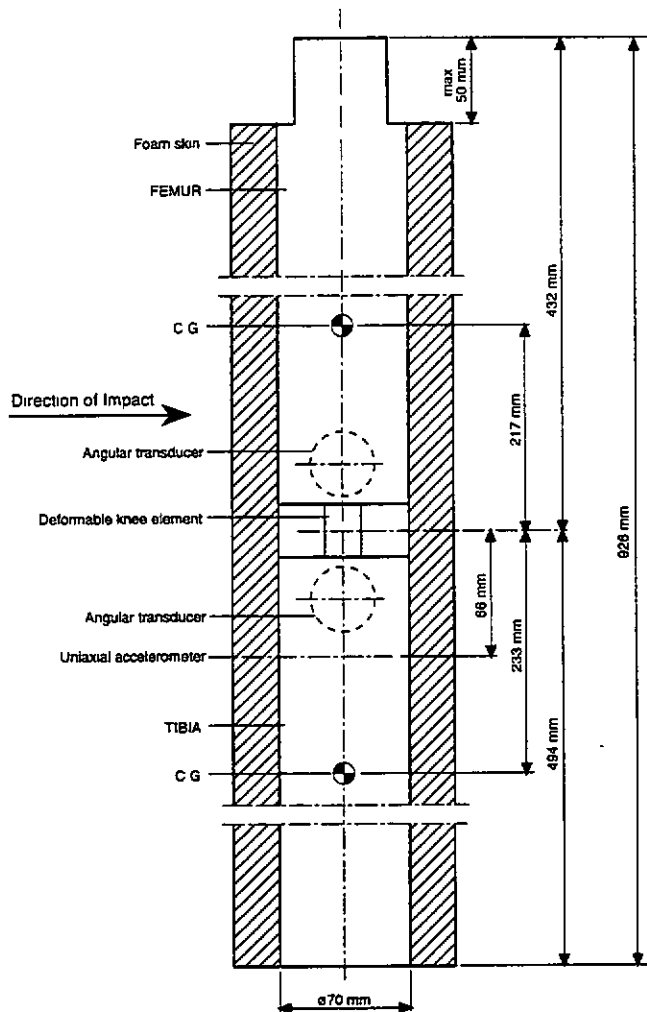

Figure 3. Legform impactor.

longitudinal vehicle axis, with the legform impactor vertical. Small tolerances to these directions are allowed. The impact position in the 'horizontal' direction is already described under 'general'. The impact position in the 'vertical' direction is prescribed by the dimensions of the legform impactor and by the bumper height; the bottom of the impactor is at ground level at the time of first contact with the bumper (see also Figure 2).

Acceptance levels - Soft tissue 'crush' injuries caused by flat bumpers were discussed within WG10. Based on an expert classification [23], it was decided to give first priority to avoidance of knee ligament rupture and bone fractures.

The proposed acceptance levels are 15 degrees of lateral knee bending rotation, 6 mm of lateral knee shearing displacement and 150 g lateral acceleration at the

top of the tibia. The 150 g acceleration value is aimed to limit the contact force applied to the tibia. The bending angle is associated with the bending moment at knee level and assesses the risk for ruptures of the knee ligaments. The acceptance level is based on cadaver tests [24].

In the second report of WG10 [14] an angle of 5 degrees was mentioned as acceptance level for shear rotation, which was based on impact forces of 4 kN and lateral shear displacements of 5-6 mm in cadavers. According to autopsies made after these tests it was found that rupture of the anterior cruciate ligament (ACL) is the typical injury associated with shearing mechanisms. When pulled it can be considered that about 25-30 mm of the ligament is lengthened and with an elongation at rupture of 20% [25], this corresponds to a limit of 5-6 mm for shearing displacement.

Upper legform to bonnet leading edge test

Full-scale tests have shown that in a pedestrian accident the leading edge of the bonnet most frequently strikes the femur and pelvis of adults and the pelvis, abdomen or femur of children. Reports from European accident studies have shown that for accidents at speeds up to 40 km/h pelvic/femur fractures of AIS 3+ were more frequently to adults than to children. Child abdominal injury of AIS 3+ was rarely seen at speeds of 40 km/h or less [14]. As a consequence the impactor that has been developed by TRL for this sub-systems test represents a segment of an adult femur.

Development of test method and impactor - Since the extension of the WG10 mandate, some improvements have been included in the upper legform design. The strain gauges are covered to protect them against damage. A test programme has been performed to evaluate the temperature/time influence on the characteristics of the flesh simulating foam and to evaluate the durability of the foam [26]. It was concluded that the influence of the temperature is limited within the prescribed range for testing. Furthermore, it was concluded that the flesh deteriorates slightly and becomes slightly softer with repeated testing, increasing the measured forces and bending moments. Therefore it is recommended to use new flesh before each regulatory test.

In 1992, TRL evaluated the existing version of the test method and concluded that the test procedure, vehicle measurement and look-up methods proved easy to understand and use [27]. Some improvements, however, were proposed by TRL and accepted by WG10; a definition of the corner reference points and a minimum

impact distance from these points, and an additional requirement to cover repairs between tests.

BASSt [19] performed tests according to the EEVC method. BASSt concluded that the definitions and corresponding measurements on the car were simple. The durability of the impactor was good. The repeatability of the test method was considered good, with only small differences in test results (i.e. 2%) between two similar tests

However, in 1995 BASSt performed again a series of tests and found a 'hidden load path' from the impact point at the front to parts of the impactor behind the load cells. The foam seems stiff enough dynamically to transmit these forces. Historically, the problem was not observed in early prototypes so it probably arose from design changes to improve the attachment method and appearance of the foam. Based on these findings and their own reanalysis TRL has improved the upper legform by reducing the area of the foam sheets that cover the impactor, so that there are gaps between the foam and the support system behind the load cells and the revised design no longer exhibits this problem.

A static calibration procedure has been developed to assess the sensitivity of the strain gauges. The dynamic certification procedure has been improved to obtain a more representative impact speed and impactor responses.

Impactor - The upper legform consists of a 350 mm long tube mounted at either end through load cells to a support frame, which is in turn mounted through a torque limiting joint to a propulsion system (see Figure 4). Supplementary weights can be attached to the support frame (i.e. rear member) to meet the impact conditions of the car under test. Strain gauges are attached to the impactor tube to measure bending moments. The impactor is covered by foam and a skin at the front side. The mass is dependent upon the general shape of the car front (see 'Test method').

Test method - The impact conditions of the upper legform to bonnet leading edge test are dependent on the shape of the vehicle to be tested.

The bonnet leading edge height and the bumper lead are determined and based on these values the impact velocity (20-40 km/h), the impact angle (10-47.4°) and the impact energy are determined (see Figures 5, 6 and 7). The impact mass (9.5-17.7 kg) is calculated from the impact velocity and energy (i.e. $2E/V^2$), and small adjustments are allowed to obtain standard increments of adjustable mass.

The impact direction is in the fore/aft vertical plane of the vehicle. Small tolerances to this direction are allowed. The impact position in the 'horizontal' direction of this

guided impact is already described under 'General'. The centre of the impactor should be aligned with the bonnet leading edge (see Figure 8).

Acceptance levels - Based on pedestrian accident reconstructions and confirmed by available results from cadaver tests [8], acceptance levels are proposed by EEVC WG10: a total (instantaneous) force of 4 kN and a bending moment of 220 Nm (measured at one or more strain gauges)

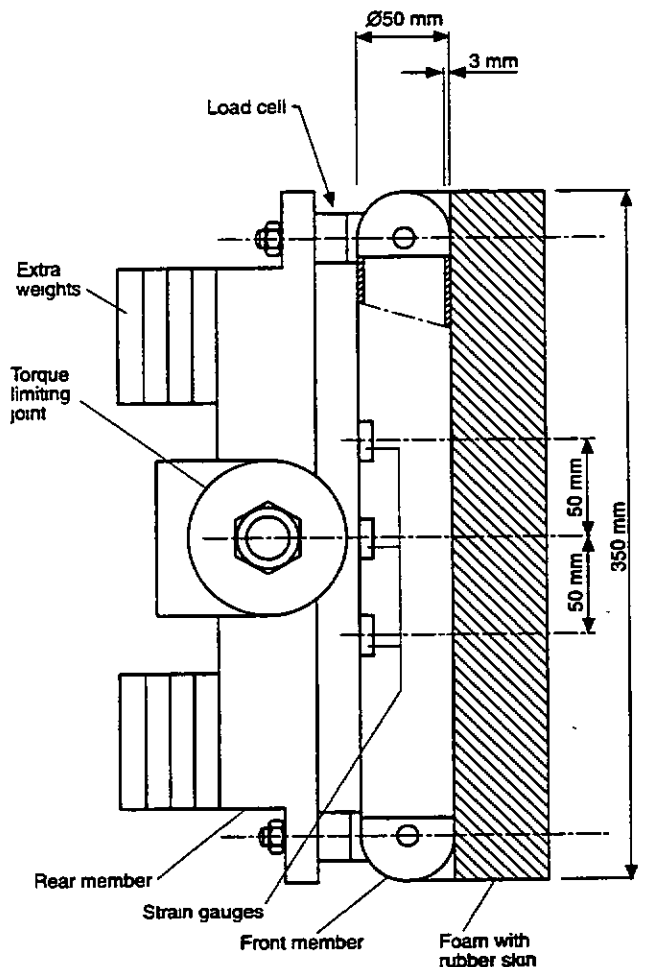
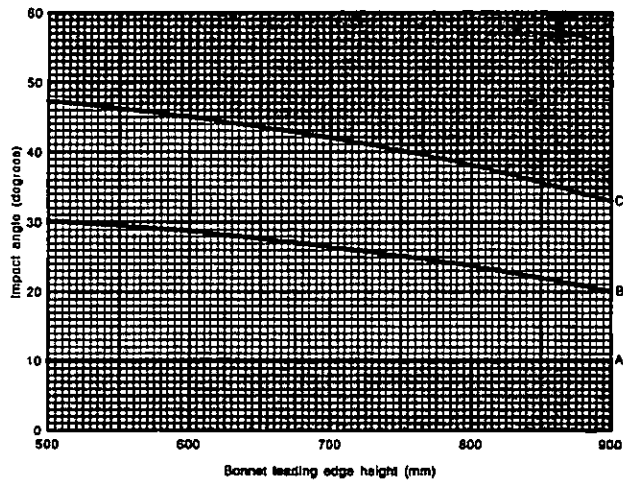

Figure 4. Upper legform impactor.



Key:-

- A ≤ 0 mm bumper lead
- B = 50 mm bumper lead
- C ≥ 150 mm bumper lead

Figure 5. Impact angle of upper legform impactor with respect to vehicle shape.

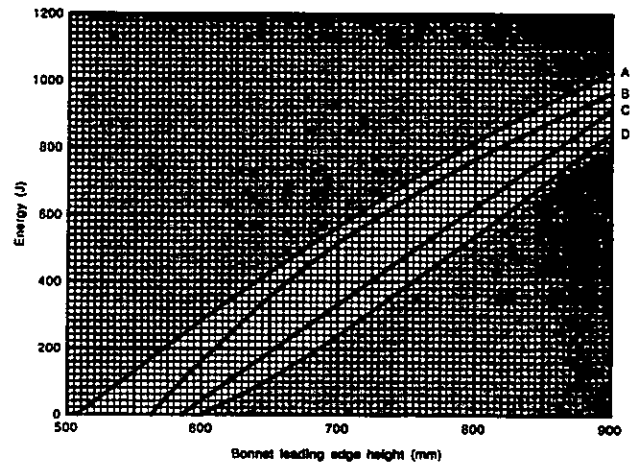

Key:-

- A ≤ 0 mm bumper lead
- B = 100 mm bumper lead
- C = 225 mm bumper lead
- D ≥ 350 mm bumper lead

Figure 7. Kinetic energy of upper legform impactor with respect to vehicle shape.

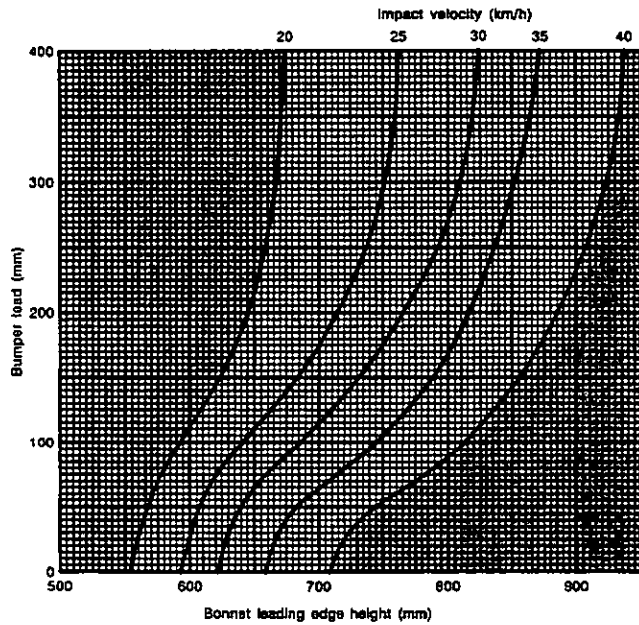

Figure 6. Velocity of upper legform impactor with respect to vehicle shape.

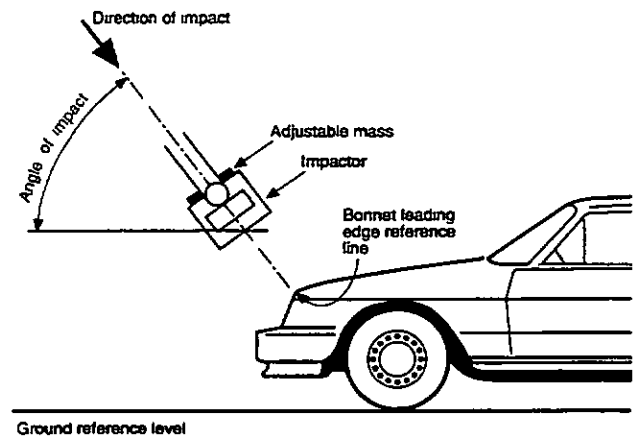

Figure 8. Upper legform to bonnet leading edge test.

Headform to bonnet tests

Accident data have shown that the head is the body region most frequently suffering from life threatening injuries in both child and adult pedestrian accidents [14]. As a consequence of these findings two assessments are included in this sub-systems test. One is based on an impactor representing a child headform to evaluate the forward section of the bonnet and wings and the second is based on an adult headform to assess the rear of the bonnet, wings and the scuttle.

Development of test method and impactors - Since the extension of the WG10 mandate, small changes were included in the design of both headforms. The centre of gravity of the headform and the accelerometer are now located more accurately in the centre of the sphere. Furthermore the (end of the) skin is connected to the sphere to avoid rotation of the sphere inside the skin during an impact. A test programme has been performed to evaluate the influence of temperature and humidity on the impact responses of the skin [19]. It was concluded that the temperature, within the prescribed range, has no influence on the headform responses. A 5-10% increase in headform acceleration could be seen when the skin was soaked for 4 hours in water. It was recommended to store the skin in a humidity-controlled room.

TRL has evaluated the test method and concluded that the procedures for identifying the test area were clear and easy to follow, the selection of test sites and the requirements for setting up and testing the car were also clear and easy to follow [28]. Only one point in the test procedure was found to require clarification; the difference between the centre of the dent on the bonnet and the line of free flight of the headform. Based on the TRL recommendation, WG10 defined the 'point of impact' as the 'point of first contact'. It was concluded that the repeatability of the impactors and test method was good.

The dynamic certification procedure has been improved, no different headform mass is required any more in the certification test. Moreover, the skin is certified now at several locations on the circumference.

Impactor - Both of the headforms developed by BASt are of spherical shape and made of a semi-rigid material, covered by a rubber skin (see Figures 9 and 10). An accelerometer is mounted in the centre of the sphere. The adult impactor has a diameter of 165 mm and weighs 4.8 kg. The child impactor has a diameter of 130 mm and weighs 2.5 kg.

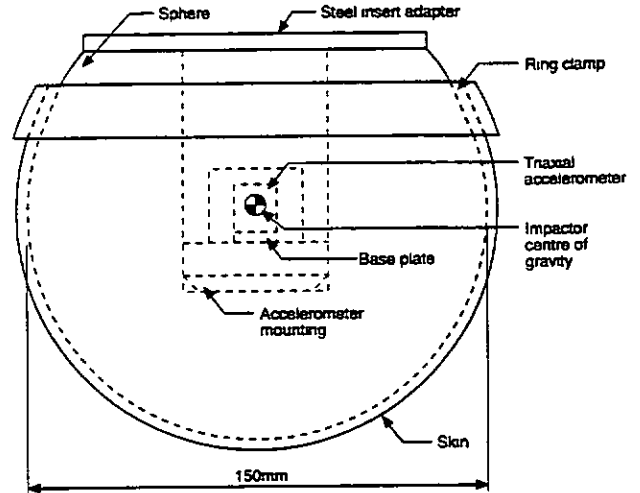

Figure 9. Adult headform impactor.

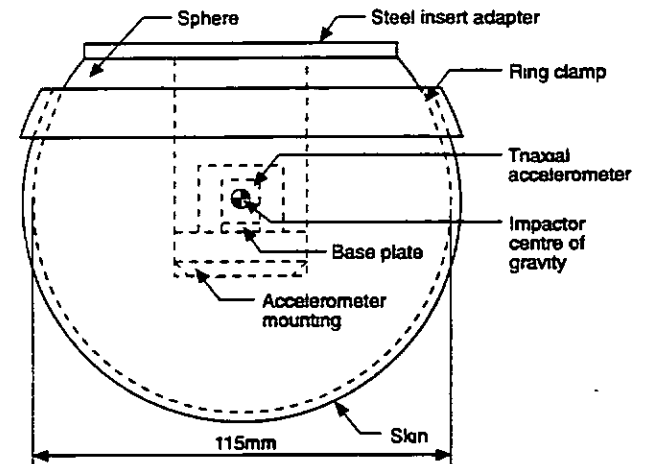

Figure 10. Child headform impactor.

Test method - It is known from cadaver tests and mathematical model simulations that the head to bonnet impact velocity can be up to 20% higher than the vehicle impact speed [14]. This would mean a headform impact velocity of 48 km/h for a simulated 40 km/h pedestrian accident. EEC WG10 decided to describe an impact velocity of 40 km/h for both the child and the adult headform to bonnet tests, because:

- headform impactor tests to a car body shell with the internal components removed have shown that it would be difficult to achieve a HIC value of less than 1000 from headform impact velocities of 45 km/h or greater;

- there is a trend to design passenger cars with a less horizontal bonnet top, resulting in head impact velocities similar to the vehicle impact speed.

The direction of impact is rearward and downward, at an angle of 50 degrees to the horizontal for the child headform tests and at an angle of 65 degrees for the adult headform tests. The impact direction is in the fore/aft vertical plane of the vehicle. Small tolerances to these directions are allowed.

The impact point on the car is defined by the point of first contact between the circumference of the headform impactor and the bonnet top. For tests to the windscreen lower frame the headform impactor should not contact the windscreen glass before impacting the vehicle structure.

Acceptance levels - Rotational accelerations have been discussed by EEVC WG10, however, it was concluded that insufficient data is available to propose an acceptance level. Therefore only linear accelerations are measured and used; the proposed acceptance level is that the Head Performance Criterion, calculated from the resultant acceleration of the headform accelerometer time histories shall not exceed 1000.

PERFORMANCE OF CURRENT VEHICLES

The performance of current vehicles with respect to the proposed test methods has been evaluated also by WG10 in several programmes. This aspect was also included in the work programme (see Figure 1) in order to assess the feasibility of the test methods.

Tests performed by INRETS showed that lowering the bumper of a medium size mass-production car by 88 mm can decrease the bending angle and shearing displacement in the legform to bumper test by more than 50%. It is concluded that it is possible to optimise the design of car front ends in terms of shape and materials to improve the protection of pedestrians against leg injuries [16].

Leg-to-bumper tests performed by the BASt according to the EEVC test method on three different cars, showed that none of the cars passed all three requirements in all three bumper tests. However, every car showed in at least one test that one or two requirements can be fulfilled [19]. It should be remembered that these cars are not designed for pedestrian protection.

TRL performed three tests on the bonnet leading edge of four popular European cars [27]. For one of the three tests to each car a 'weak' test point was selected rather than the point most likely to cause injury. This was done to get a measure of the best performance achieved by current cars. All cars exceeded the proposed acceptance

levels. All four cars had heavy under-bonnet reinforcement which was carried right to the bonnet leading edge. Relatively simple changes to the car/bonnet design, such as moving the reinforcement back from the leading edge, would probably be sufficient to pass the test [27].

Upper legform to bonnet leading edge tests on three different cars have been performed by the BASt. Large differences in test results were found between tests on different points of one car and between different cars. All requirements were passed in one test on one of the 3 cars [19].

In 1992 BASt performed a series of headform impactor tests on 9 (popular) cars [29]. Only the bonnet (i.e. the moving part) was used as test area and not the wings, scuttle, etc. All points which seemed to be dangerous were tested with no restriction to the number of tests in each sub-area (as described by the EEVC test method). In 42% of all tests with the adult headform, the HIC was less than 1000, and in 31% the HIC was between 1000 and 1500. For the child headform tests, only 14% resulted in a HIC value below 1000, while in 48% of these tests the result was between 1000 and 1500. Large differences between cars were found; from 83% below HIC 1000 for one car to 100% above HIC 1500 for another car. By means of double integration of the acceleration time histories, it was found that for obtaining a $HIC \leq 1000$ in the child head impact test a minimum distance of 50 mm is required between the bonnet and a stiff under-bonnet surface, for the adult head impact test 70 mm is sufficient [30]. Theoretical studies showed that with even less distance to the substructure the requirement can be met [31].

TRL performed headform impacts on 4 cars according to the EEVC test method [32]. Since the adult test area was narrow on all cars and to reduce costs of testing, it was decided to reduce the number of adult headform tests. None of the tests resulted in HIC values below 1000, however, several test sites came close to passing the requirements, taking the non-linear effects of the HIC calculation into account. One car was close to passing at most test sites. Results of headform-to-bonnet tests on a 4x4 utility vehicle with an aluminium bonnet were discussed within WG10. In one out of four child headform tests and one out of four adult headform tests the requirement was fulfilled.

Several test programmes to current cars have shown that it is technically possible to fulfil the requirements proposed in the EEVC test method with new car designs. Several design guidelines have been developed, based on the experience gained in these programmes [33].

Bull-bars

TRL and BAST performed several tests on so-called bull-bars or crash-bars fitted to the front of off-road vehicles. Tests with the upper legform impactor [34, 35] and tests with the child headform impactor [35, 36] showed how pedestrian unfriendly these bent and welded steel tubes are.

Tests with the legform impactor showed, surprisingly, a decrease in bending angle and shearing displacement compared with the same off-road vehicle without a crash-bar. However, the tibia acceleration was increased indicating the higher stiffness of the crash-bar [35].

In Germany the percentage of off-road vehicles in the total number of cars is above 1% and approximately 62% are equipped with crash-bars. It is suggested that the proposed Directive should not only cover manufacturer mounted crash-bars, but be extended to cover also crash-bars fitted as after-market accessories [34].

COST BENEFIT STUDIES

Introduction of the EEVC pedestrian test methods as a Directive should reduce the large number of killed and seriously injured pedestrians in Europe. Indications for savings were already given in the previous reports of WG10 [12, 14].

Since then several members of EEVC WG10 have been involved in cost-benefit studies concerned with the proposed Directive, however these studies were not part of the mandate of WG10 and were not extensively discussed. Further details can be found in [37, 38, 39, 40].

CONCLUSIONS

EEVC Working Group 10 started its activities in 1988 with the task 'to determine test methods and acceptance levels for assessing the protection afforded to pedestrians by the fronts of cars in an accident. The test methods should be based on sub-system tests, essentially to the bumper, bonnet leading edge and bonnet top surface'. The studies necessary to develop test methods were already presented in a *first* report of EEVC WG10, published in 1989 [5]. The first results of the studies and the first version of the test methods was described in the *second* WG10 report, published in 1991 [14].

Since then the proposed test methods, including the sub-system impactors, have been evaluated thoroughly. Improvements have been included in the design of the impactors and in the test procedures. The procedures seem

easy to follow and the test methods appear to be reproducible and sensitive to vehicle design changes. These developments are described in the *third* report of EEVC WG10 [15].

The headform and upper legform impactors are now available on a commercial basis. Prototype legform impactors have been available for some time and it is expected that a final version could be available in the summer of 1996.

Several test programmes to current cars have shown that it is technically possible to fulfil the requirements proposed in the EEVC test method with new car designs, however, a phased-in introduction of the requirements seems feasible. It is suggested that the proposed regulation to be extended to cover also crash-bars or bull-bars fitted as after-market accessories, since several test programmes have shown how pedestrian unfriendly these (steel) bars are.

The pedestrian protection methods discussed in this paper are only intended for the fronts of cars up to a wrap around distance of 2100 mm or to the base of the windscreen. However, other parts of cars are also responsible for severe or fatal pedestrian injuries: the A-pillar, windscreen and upper windscreen frame. Buses and coaches, heavy goods vehicles and motorcycles are also involved in a considerable number of pedestrian accidents. Thus, further research is required in these areas.

ACKNOWLEDGMENTS

The work presented in this paper has been conducted by the (former) members of EEVC WG 10 (see Appendix 1).

REFERENCES

1. European Experimental Vehicles Committee:
Pedestrian injury accidents.
Presented to the 9th ESV Conference, Kyoto, November 1982.
2. European Experimental Vehicles Committee:
Cycle and light-powered two-wheeler accidents
Presented at the 9th IRCOBI Conference, Delft, September 1984.
3. European Experimental Vehicles Committee:
Pedestrian injury protection by car design.
Presented to the 10th ESV Conference, Oxford, July 1985.
4. Commission of the European Communities:
Frontal surfaces in the event of impact with a vulnerable road user.
Ad-hoc Working Group ERGA Passive Safety, document ERGA S/60, Brussels.
5. European Experimental Vehicles Committee:
Study of test methods to evaluate pedestrian protection for cars.
EEVC Working Group 10 report, presented to the 12th ESV Conference, Gothenburg, May 1989.
6. Janssen, E.G., Nieboer, J.J.:
Protection of vulnerable road users in the event of collision with a passenger car, Part I - Computer simulations.
TNO Report No. 75405002/I under Contract No. ETD/89/7750/M1/28 to the European Commission, December 1990.
7. Janssen, E.G. et al.:
Protection of vulnerable road users in the event of collision with a passenger car, Part II - Sub-systems test method evaluation and compatibility study.
TNO Report No. 75405002/II under Contract No. ETD/89/7750/M1/28 to the European Commission, December 1990.
8. Lawrence, G.J.L. et al.:
Development of a bonnet leading edge sub-systems test to assess protection for pedestrians.
TRRL report under Contract No. ETD/89/7750/M1/28 to the European Commission, January 1991.
9. Glaeser, K.-P.:
Development of a Head Impact Test Procedure for Pedestrian Protection.
BASt report under Contract No. ETD/89/7750/M1/28 to the European Commission, June 1991.
10. Cesari, D., Alonzo, F.:
Assessment of Test Methods to evaluate the protection afforded to pedestrians by cars.
INRETS report under Contract No. ETD/89/7750/M1/28 to the European Commission, December 1990.
11. Brun-Cassan, F.:
Assessment of Test Methods to evaluate the protection afforded to pedestrians by cars - Compatibility.
APR report under Contract No. ETD/89/7750/M1/28 to the European Commission, July 1991.
12. Commission of the European Communities:
Summary of the work of the consortium developing test methods to evaluate the protection afforded to pedestrians by cars (including test proposals).
European Commission Study Contract No: ETD/89/7750/M1/28, July 1991.
13. Commission of the European Communities:
Draft proposal for a Council Directive adapting to technical progress Council Directive 74/483/EEC relating to the external projections of motor vehicles including their effect on pedestrians.
Document III/4025-92, Brussels, April 1992.
14. European Experimental Vehicles Committee:
Proposals for test methods to evaluate pedestrian protection for cars.
EEVC Working Group 10 report, presented to the 13th ESV Conference, Paris, November 1991.
15. European Experimental Vehicles Committee:
Proposals for methods to evaluate pedestrian protection for passenger cars.
EEVC Working Group 10 report, November 1994.
16. Cesari, D. et al.:
Optimization of pedestrian leg injury protection using a biofidelic human leg.
Presented at the 1994 International Conference on the Biomechanics of Impacts, Lyon, September 1994.

17. Cesan, D. et al.:
Subsystem test for pedestrian lower leg and knee protection.
Presented to the 13th ESV Conference, Paris, November 1991.
18. Lawrence, G.J.L., Hardy, B.J.:
Evaluation of the leg to bumper impactor proposed for the EEVC pedestrian impact test procedure.
TRL Unpublished Project Report PR/VE/66/93, S220C/VF, 1993.
19. Zellmer, H.:
Evaluierung des Prüfverfahrens der EEVC WG10 zur Bestimmung der Fußgängerverträglichkeit von Pkw-Frontflächen (Evaluation of the EEVC WG10 test methods to assess the protection afforded to pedestrians by the front of cars).
BASt report, July 1994.
20. Robbins, D.H.:
Development of anthropometrically based design specifications for an advanced adult anthropomorphic dummy family.
Report no. UMTRI-83-53-2, Ann Arbor, 1983.
21. Faerber, E.:
Legform impact tests to evaluate the TRL legform impactor for the EEVC WG10 test procedure for car related pedestrian protection.
BASt report, Bergisch Gladbach, December 1995.
22. Saladin, A.:
Prototype TRL legform impactor evaluation and dynamic certification tests.
TNO report no. 96. OR.BV.011.1/AS, Delft, March 1996.
23. Cavallero, C.:
Inventory of possible injuries on the pedestrian lower-limb level - Personal communication to EEVC WG 10.
INRETS, Marseille, 1992.
24. Cesan, D. et al.:
Mechanisms producing lower extremity injuries in pedestrian accident situations.
Proceedings of the 33rd AAAM Conference, Baltimore, 1989.
25. Yang, J.:
Impact Biomechanics of the Lower Extremity in Traffic Accidents - Development and Validation of a Mathematical Model.
Chalmers University of Technology, Thesis, Gothenburg, March 1994.
26. Lawrence, G.J.L., Hardy, B.J.:
An improved certification method for the pedestrian upper legform impactor.
EEVC WG10 document, 13-9-1994.
27. Lawrence, G.J.L., Hardy, B.J.:
Report on tests using the draft directive for pedestrian protection on cars.
EEVC WG10 document, 25-11-1992.
28. Lawrence, G.J.L., Hardy, B.J.:
Evaluation of the head impactors proposed for the EEVC pedestrian impact test procedure.
TRL Unpublished Project Report PR/VE/34/93, S220C/VF, 1993.
29. Zellmer, H., Glaeser, K.-P.:
Performance of current cars in pedestrian accidents tested with the proposed EEVC head impactor.
BASt report, November 1992.
30. Zellmer, H., Glaeser, K.-P.:
The EEVC WG10 head impact test procedure in practical use.
Presented to the 14th ESV Conference, Munich, May 1994.
31. Okamoto, Y. et al.:
Concept of hood design for possible reduction in pedestrian head injury.
Presented to the 14th ESV Conference, Munich, May 1994.
32. Lawrence, G.J.L., Hardy, B.J.:
Evaluation of four cars using the EEVC pedestrian head impact test procedure.
TRL Unpublished Project Report PR/VE/76/94, S220C/VF, 1994.
33. Lawrence, G.J.L., Hardy, B.J.:
Final report on pedestrian protection test procedures and design.
TRL Unpublished Project Report PR/VE/81/94, S220C/VF, 1994.

34. Lawrence, G.J.L., Hardy, B.J.:
Vehicle crash bars - Assessment of pedestrian injury potential.
TRL Unpublished Working Paper WP/VS/225, S220C/VF, 1992.

35. Zellmer, H.:
Quantifizierung der Gefährdung von Fußgängern durch Frontschutzbügel an Geländefahrzeugen (Assessment of pedestrian protection afforded by crash-bars).
BAST report, Arbeitsprogramm-Nr.: 94 552, August 1994.

36. Zellmer, H.:
Test on crash bars for off-road vehicles with the EEVC WG10 child head form.
BAST report, June 1993.

37. Association des Constructeurs Europeens d'Automobiles:
Pedestrian Accidents in Europe - Developments and Challenges.
ACEA report, Brussels, September 1992, updated September 1993.

38. Lawrence, G.J.L et al.:
Costs and benefits of the EEVC pedestrian impact requirements.
TRL project report 19, S220C/VF, Crowthorne, 1993.

39. Bamberg, R., Zellmer, H.:
Nutzen durch fahrzeugseitigen Fußgängerschutz (Benefits from Vehicle-Pedestrian Protection Measures).
Berichte der BAST, Fahrzeugtechnik Heft F5, Bergisch Gladbach, April 1994.

40. Van Kampen, L.T.B.:
Cost-benefit study concerning car front impact requirements to increase the crash-safety of pedestrians and cyclists.
SWOV report no. R-94-31, Leidschendam, 1994.

APPENDIX I

Members/attenders of EEVC WG10 in 1991-1994

| | |
|-------------------------|-----------------|
| M. Beusenber | TNO (secr.) |
| mrs. F. Brun-Cassan | LAB |
| Y. Caire | INRETS |
| D. Cesari | INRETS |
| E. Faerber | BAST |
| A. Giles | SMMT/Rover |
| K.-P. Glaeser | BAST |
| P. Goudswaard | TNO (secr.) |
| N. Grew | SMMT/Rover |
| B. Hardy | TRL |
| W. Heiss | Mercedes-Benz |
| E. Janssen | TNO (chairman) |
| G. Lawrence | TRL |
| R. Lowne | TRL |
| P. Massaia | FIAT |
| A. Saladin | TNO (secr.) |
| mrs. I. Skogsmo-Planath | Volvo Car Corp. |
| R. Worth | DoT/UK |
| H. Zellmer | BAST |