

Mobility

Van Mourik Broekmanweg 6
2628 XE Delft
P.O. Box 49
2600 AA Delft
The Netherlands

www.tno.nl

T +31 88 866 30 00
F +31 88 866 30 10
infodesk@tno.nl

TNO report

TNO 2012 R10679 | Final

**Report of the Research Program on an
Emissions and CO₂ Test Procedure for
Heavy Duty Hybrids (HDH)**

Date	27 September 2012
Author(s)	Stefan Hausberger - TUG G�rard Silberholz - TUG Antonius Kies – TUG Henk Dekker – TNO
Example number	TNO-060-DTM-2012-03353
Number of pages	51 (incl. appendices)
Number of appendices	0
Sponsor	European Commission DG Enterprise and Industry Directorate D - Industrial Innovation and Mobility Industries
Project name	Developing the Methodology for Certifying Heavy Duty Hybrids based on HILS
Project number	057.01451

All rights reserved.

No part of this publication may be reproduced and/or published by print, photoprint, microfilm or any other means without the previous written consent of TNO.

In case this report was drafted on instructions, the rights and obligations of contracting parties are subject to either the General Terms and Conditions for commissions to TNO, or the relevant agreement concluded between the contracting parties. Submitting the report for inspection to parties who have a direct interest is permitted.

  2012 TNO

Summary

The main goal of the project is to assess the Japanese HILS certification method as a basis for the development of an emissions and CO₂ test procedure for Heavy Duty Hybrids (HDH), which should be worldwide established. The test procedure should be based on the HILS (Hardware-in-the-Loop Simulation) method. The final worldwide HILS method should be – as far as reasonable - in agreement with the test procedure for conventional engines, i.e. the WHTC and the WHVC (World Harmonized Vehicle Cycle), the test cell environment, data evaluation procedures and emissions calculations specified in GTR No.4 under the 1998 Global Agreement.

Following the existing Japanese HILS method the approach planned was to develop a procedure starting with a vehicle cycle (speed pattern) and by using a vehicle model, a driver model and models of motor/generator and energy storage and the real ECU hardware and software transforming the vehicle cycle into a specific engine cycle by using Hardware In the Loop simulation. This new engine cycle is then used for testing the pollutant emissions on the engine test bench in the same way as it is done for a conventional engine.

The main work within the first phase of the project was evaluating existing procedures and software and elaborating a plan how to transfer these into a GTR version of a HILS test method. Related options for amendments of methods, of software and of data are also provided in the report. Based on these findings the strategy for phase two of the project was elaborated. Following main findings were made in the first project phase:

The Japanese HILS procedure and the HILS open source model were evaluated and possible enhancements (e.g. more topologies, component library, temperature signals to include cold start tests) were proposed.

In general the simulation model provides a good basis for a global regulation, but more work is needed before a worldwide test procedure can be drafted.

The review of vehicle related data resulted in three different options for the realisation of a World Heavy Duty Hybrid Cycle (WHDHC) which leads to power demand cycles at the power pack shaft which are similar to the test cycle for conventional engines (WHTC). The set of cycles comprise a vehicle speed cycle, a wheel hub power cycle and a power pack shaft cycle.

An important issue is to agree on a method to determine how the full load curve for hybrid power packs has to be defined.

It is not recommended to include PTO power demand in the test procedure for regulated pollutants since this would not be in line with the test procedure for conventional engines. PTO operation can be considered for the test procedure for CO₂ emissions of the entire vehicle. Options are the use of a benefit factor according to US EPA 40 CFR 1037.525 or including PTOs in the simulation tool or a combination of both.

A method to calculate WHVC weighting/scaling factors to represent real world vehicle operation was developed.

Also options to coordinate the HDH test procedure with CO₂ test procedures for Heavy Duty Vehicles (HDV) have been elaborated.

Abbreviations

AC	Air conditioning
CAP.....	Cooling Capacity [kW]
COP	Coefficient of Performance of an AC system [kW refrigerating capacity / kW power input to the compressor]
c_p	specific heat capacity [kJ/kg*K]
ECU	Engine Control Unit or general Electronic Control Unit
h	Enthalpy [kJ/kg]
HDV	Heavy Duty Vehicle
HCU	Hybrid Control Unit
HDH	Heavy Duty Hybrid
HILS.....	Hardware-In-the-Loop Simulation
HVAC.....	Heating Ventilation and Air Conditioning
ICE	Internal Combustion Engine
m	mass [kg] or mass flow [kg/s]
p.....	pressure [bar]
P.....	power [kW]
PTO.....	Power take Off
Q	heat or heat flow
R	Gas constant [kJ/kg*K]
r.....	latent heat [kJ/kg]
T.....	Temperature [°C or K]
x	absolute humidity [kg water / kg dry air]
·	relative humidity [-]

Contents

	Summary	2
	Abbreviations.....	3
1	Introduction.....	5
2	Summary Report.....	6
2.1	Task 1.2: Review of vehicle-related data.....	6
2.2	Task 4: Inclusion of PTO operation	10
2.3	Task 5: Development of WHVC weighting/scaling factors to represent real world vehicle operation.....	12
3	Detailed description of the tasks	16
3.1	Task 1.2: Review of vehicle-related data.....	16
3.2	Task 4: Inclusion of PTO operation	25
3.3	Task 5: Development of WHVC weighting/scaling factors to represent real world vehicle operation.....	41
4	References	50
5	References	51

1 Introduction

The HDH research program is executed by the Institute for Powertrains and Automotive Technology of the Vienna University of Technology (IFA), by the Institute for Internal Combustion Engines and Thermodynamics of the Graz University of Technology (TUG), by the Department of Signals and Systems of the Chalmers University of Technology and by TNO. The project is sponsored by the European Commission, OICA, Sweden and the Swedish Energy Agency (SEA).

This report describes the work performed by TUG within the research program on an emissions and CO₂ test procedure for Heavy Duty Hybrids (HDH) in phase 1 of the project.

The report is structured as follows:

Chapter 2 is almost identical to the relevant text of the “Summary Report” [1] of phase 1 of the project. Small amendments were done in the wording and in adding explanations how the normalised power course of the WHDHC was elaborated. Chapter 3 gives background information for work related to the sub-chapters of the summary report which were elaborated by TUG. Background information to the work from Chalmers and from IFA is given in separate final reports. This structure may facilitate the compilation of all information into one final report and may possibly also prevent unnecessary re-reading of the summary report.

2 Summary Report

2.1 Task 1.2: Review of vehicle-related data

Regulated pollutant emissions of conventional heavy duty engines for certification are being determined on an engine test bed using the world-harmonized test cycles WHSC and WHTC. The WHTC test cycle depends on the shape of the full load curve of the engine and leads to load points of the engine both in part and full load (Figure 1).

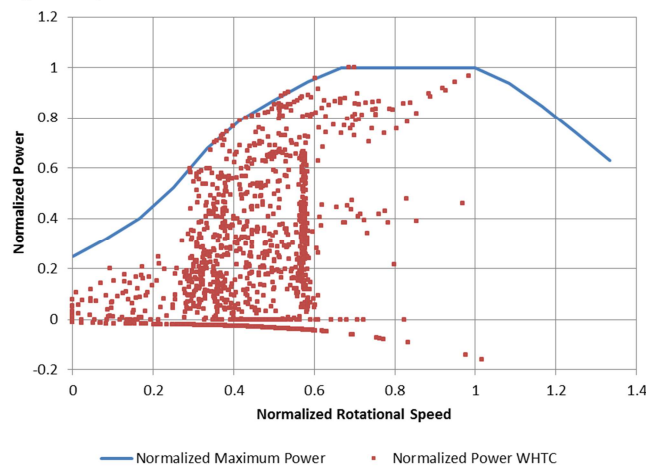

Figure 1: WHTC load points in 1 Hz (exemplary for one particular engine)

In the original Japanese HILS approach (Kokujikan No. 281) a vehicle speed cycle over time is used as input. However, the resulting engine load cycle will depend on the vehicle parameters when a vehicle speed cycle is used as input. Therefore especially engines of vehicles with high power to mass ratio are operated in part load only and the engine would never be run at load points with high power or even full load for pollutant emission certification purposes. As a result, emissions measured for conventional engines and for heavy duty hybrids might not be comparable. Figure 2 shows these facts for two vehicles according to the Japanese standard vehicle specification for the exhaust gas test procedure for heavy duty vehicles. These two vehicles driving the WHVC were simulated with the software PHEM. The same engine data was used for both vehicles, while the vehicle data was set according to Kokujikan No. 281. The result for the T4 vehicle with a very high power to mass ratio of 28 kW/ton shows large areas in the power pack map not covered by the test procedure. For more typical power to mass ratios the areas not covered by the test procedure are smaller but still can occur especially around the full load curve of the engine.

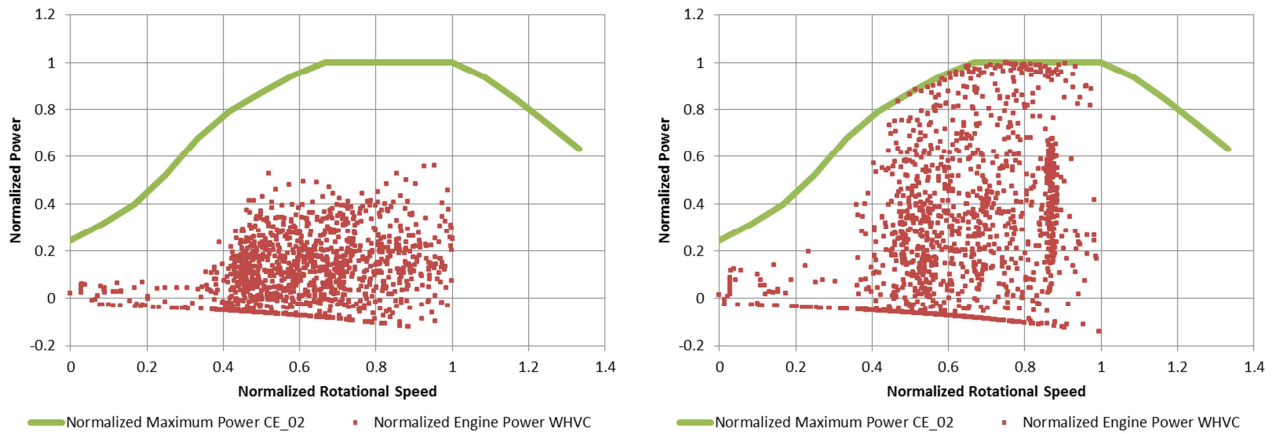

Figure 2: Left: Japanese T4 vehicle (mass 8,450kg, 240kW rated power) in WHVC
Right: Japanese T7 vehicle (mass 24,662kg, 240kW rated power) in WHVC

A new test cycle called WHDHC (world heavy duty hybrid cycle) was developed, which takes the shape of the hybrid power pack full load curve into account and thus leads to similar load points for hybrid power packs as the WHTC for conventional engines.

2.1.1 Generation of the WHDHC

In order to get similar load cycles for heavy duty hybrid power packs and conventional heavy duty combustion engines, a new method for generating the WHDHC was developed. This new test cycle depends only on the full load curve of the power pack system and not on vehicle related data. This makes the type approval of a hybrid power pack generally more comparable to conventional combustion engines.

Based on the hybrid power pack full load curve, the load cycle is calculated according to the WHTC method. So far, this step is not different from the procedure for conventional engines. From this WHTC load cycle, a fixed fraction for vehicle drivetrain losses¹ is subtracted to get the power cycle at the wheel hubs. To allow for charging of a hybrid vehicle's RESS (rechargeable energy storage system) during phases of deceleration, a corresponding negative power course for mechanical braking is added in the existing motoring phases of the WHTC². Figure 3 shows the resulting differences between WHTC and WHDHC.

¹ Efficiencies as used in the actual Japanese HILS model (Kokujikan No. 281).

² As a nature of an engine test cycle the WHTC has negative power only down to the engines motoring curve.

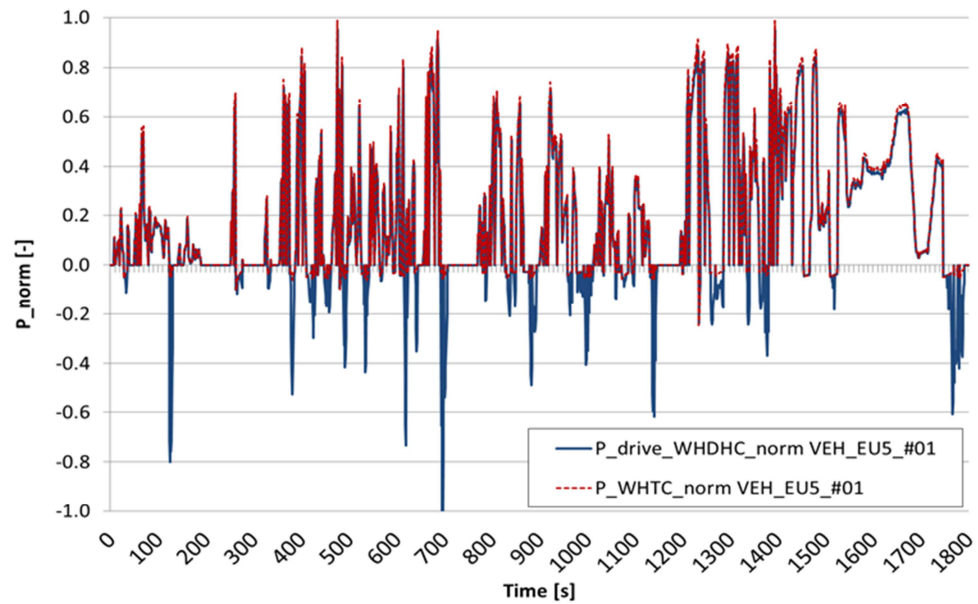

Figure 3: Power course of WHTC vs. WHDHC (exemplary for one particular vehicle)

2.1.2 Negative power for the WHDHC

The main task was to develop a normalized negative power (mechanical braking and engine motoring) course, which is representative for all vehicle categories. Analysis of real world driving data for several city buses in Vienna showed that the corresponding negative power cycle for the WHDHC is not dependent on the shape of the full load curve but can be normalized with the vehicle's rated power. For this task 13 generic heavy duty vehicles according to HBEFA 3.2 were simulated in the WHVC with the software PHEM and the resulting absolute values for negative power were normalized by the vehicle's rated power. From the results for these 13 generic heavy duty vehicles an average normalized negative power course was calculated ("P_neg_norm_average" in Figure 4 representing the "average normalized negative power cycle").

Another issue was the dependency of the negative power on the vehicle category. Due to less frontal area per kW rated power and advanced aerodynamic measures, long haulage vehicles have lower air resistance per kW rated power. Therefore, more normalized mechanical braking is necessary for large, long haulage HDV than for smaller trucks (Figure 4, right corner). To account for the influence of vehicle categories, a correction factor for the average normalized negative power cycle was developed by calculating the line of best fit for the data of all analysed vehicles. The average normalized negative power cycle shown in Figure 4 has to be multiplied by this correction factor and by the vehicle's rated power to get the absolute negative power over time for one particular vehicle in the WHDHC. Since both, $P_{neg_norm_average}$ and the P-Rated-Factor are normalised to the rated engine power, the rated power of the power pack is multiplied two times in Equation 1 (see chapter 3.1.1.2 for the derivation of the equation). In a final version the $P_{neg_norm_average}$ may be applied in absolute values with a then differently calibrated P-Rated-Factor.

$$P_{negative\ WHDHC}(t) = P_{neg_{normaverage}}(t) \times P_{Rated_Factor} \times P_{rated\ Powerpack}$$

with $P_{Rated_Factor} = 0.00367 * P_{rated\ Powerpack}$

Equation 1: Calculation of absolute negative power in WHDHC

Certainly these two equations can be merged to have a very simple and compact application.

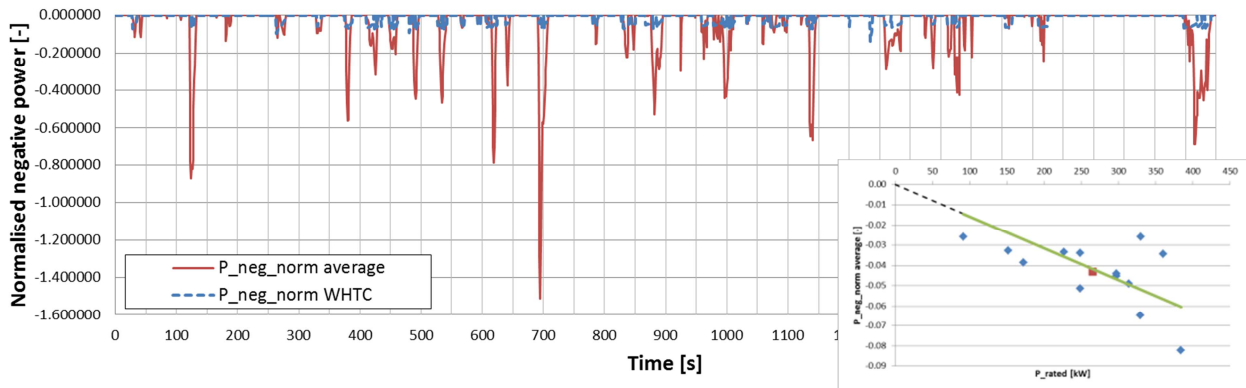

Figure 4: Average normalized negative power (P/P_{rated}) in the WHVC vs. normalized negative power in the WHTC

A Microsoft Excel tool was developed to automatically calculate the three versions of WHDHC test cycles as described in chapters 2.1.1 and 2.1.2 for a given full load curve of a particular hybrid power pack.

2.1.3 Different options for the WHDHC

There are different options to feed the WHDHC into a HILS model:

- B-1) As power cycle at the wheel hubs together with the WHVC as speed cycle. The existing HILS model needs then an adapted driver model to control the rotational speed at the wheel hub instead of the vehicle speed.
- B-2) As power cycle at the power pack shaft. The speed signal can be either the original WHTC engine speed or the rotational speed computed from the WHVC vehicle speed via the transmission ratios. The existing driver model in HILS also needs to be adapted with this version.
- B-3) The WHVC as vehicle speed cycle with individually calculated road gradient cycle, vehicle mass, air resistance and driving resistance data to create the same power cycle as the WHDHC at the wheel hub. An adaptation of the driver model would not be necessary for B-3) but the road gradient needs then to be considered in the set of vehicle longitudinal equations.

Option B-2) presents a simple method, since there is no gear box model needed. However, for some hybrid systems B-2) may not be applicable and for some hybrid vehicles the engine speed cycle from the WHTC may result in an unrealistic load cycle. This issue needs further validation work in the next phase of the project. For Option B-1) the load cycle simulated in HILS at the power pack depends on the gear box model. If only generic gear box models with fixed generic efficiencies for direct and indirect gears are used, the result should be very close to B-2) in all applications. It is not clear yet, if some future HDH would involve modelling of complex automatic or automatized gear boxes in a HILS system for realistic results. In this case option B-2) may be preferable.

Option B-3) would be necessary for hybrid systems where different axles are driven by different engines and/or electric motors.

Figure 5 shows the options B-1) and B-2). Both are ready to be used also on power pack test stands. All three options should give similar load cycles at the shaft of the power pack and all three options will not depend on vehicle specific data but only on the full load curve of the power pack. It is suggested to implement all three options in the HILS simulator to enable a comparison during the development phase of the HILS method. Maybe also in the final HILS version all options can be offered and the user selects the best option, which may depend on the HDH system under consideration.

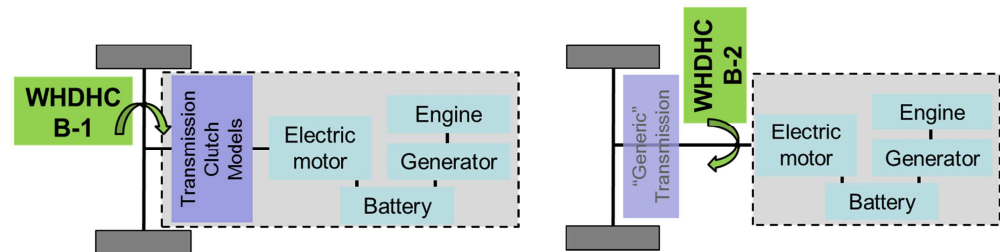

Figure 5: Different options to feed WHDHC into HILS model

For the verification of the HILS simulator set up the course of the torque at the wheel hub from on board measurements of the HDH can be used as input.

2.1.4 Open issues and necessary adaptations in the Japanese HILS method

The normalization of the rpm for heavy duty hybrid power packs needs to be further validated in the next phase of the project and adapted when necessary. The issue here is that for conventional engines the rpm values are normalized between idle speed being 0 and rated speed being 1. Since idle speed can be 0 rpm for hybrid power packs the de-normalisation of given load cycles results in slightly lower speeds and thus slightly lower power for hybrid power packs. Further investigation is necessary to determine whether these coherences pose a problem for the comparability of the WHTC method for conventional engines and the WHDHC method for hybrid power packs.

Since the WHDHC method is based on the full load curve of a hybrid power pack, a generally agreed method to determine the full load curve for hybrid power packs has to be defined. At the moment the summation of the full load curve of the engine and of the electric motors seems to be a reasonable approach where the short term maximum power of the motors shall be applied (see also chapter 3.1.1.1).

2.2 Task 4: Inclusion of PTO operation

2.2.1 Task 4.1: Options to simulate PTO power demand and Task 4.2: Options to transfer different engine work into a benefit system

Hybrid vehicles are in the position to deliver power demands from PTOs partly from recuperated energy and/or from engine operation in more favourable engine operating points. Therefore PTO power demand could be delivered by a HD Hybrid vehicle at lower specific emissions than by a conventional vehicle. Options to take this advantage into consideration have been analysed here.

The analysis leads to the following conclusions:

- 1) PTO operation adds a rather small proportion of average engine power over a driving cycle. Simulation runs based on EURO V engine emission maps in the WHVC with a constant additional engine load to simulate PTO

operation did not show significant changes in the resulting emissions in [g/kWh]. This result meets the expectations.

- 2) PTO power demand is not included in WHTC test cycle for conventional engines. Thus adding a power demand for PTO operation only to the WHDHC but not to the WHTC would not be a benefit for hybrid systems.
- 3) Changing the WHTC to include also PTO power demand is possible but the small influence on the resulting [g/kWh] seems not to justify the effort to change the established cycle.
- 4) Alternatively to an adaptation of the WHTC also the WHDHC could be adapted by just reducing the load cycle by a constant value to have then room to simulate an additional PTO power demand. Since the WHTC has zero load at idling, a "PTO reduction factor" cannot be applied where it should be applied for many HDV categories, i.e. at idling. Otherwise the basic simulation "without PTO" would run idling conditions at negative engine loads and would also not reach full load at other driving conditions.
- 5) As a final solution PTO benefits could be based on a "PTO_{benefit-factor}". The HILS model could be run with and without PTO power demand. To obtain the benefit-factor the same simulations would be necessary for the conventional power train system. The benefit factor could then be the ratio of engine work from the HDH power pack to the engine work from the conventional system. Such a correction factor could be applied to the measured emissions³. Following the approach from US EPA 40 CFR 1037.525 for CO₂ emissions this benefit factor could also be obtained by measurements instead of simulation.

However, since it is unlikely, that the regulated pollutant emissions in [g/kWh] change proportionally to the engine work, this method will not lead to founded results for NO_x, PM, PN, HC and CO but just to incentives to optimise the PTO connection to the hybrid system.

As a result of the investigations it is not recommended to consider PTO in the HILS method for the calculation of the engine test cycle for the regulated pollutants. The situation is different for CO₂. For energy consumption and CO₂ small improvements are already relevant and in addition the test methods for CO₂ from HDV are still under development and may be adapted more easily than the WHTC. Assuming that the HILS simulator will be applied also in context with the HDV-CO₂ test procedure to simulate the fuel consumption (or just the engine power and rpm course) as outlined in chapter 2.3.3, the test cycle for conventional and for hybrid vehicles could include a power demand for PTO for the vehicle classes where PTO operation is relevant. The PTO-cycle can be defined as course over time and distance together with the vehicle speed and the road gradient as outlined in the actual suggestion for a European HDC-CO₂ test procedure. Vehicle classes with relevant PTO operation are e.g.:

- Garbage trucks (compression work)
- City bus (air conditioning system)
- Municipal utility (e.g. road sweepers)
- Construction (e.g. work of a crane)

³ $[\text{g/kWh}]_{\text{corr}} = [\text{g/kWh}]_{\text{measured}} * \text{PTO}_{\text{benefit factor}}$

2.2.2 *Task 4.3: Collection of data for one vehicle mission profile*

It was agreed in the HDH group that as an example a PTO power demand cycle for the air conditioning (AC) cycle of a city bus shall be elaborated. A test cycle for hydraulic power take off is already available from US EPA.

To elaborate the AC cycle, a simulation tool developed in an earlier project for DG-ENTR was used to assess the mechanical power demand from the AC system as function of ambient temperature and humidity. The influence of the glazing quality could be considered by a correction factor. The data simulated was supplemented by measurements on a city bus in Graz which has an electric driven AC system. For which ambient conditions of temperature and humidity the cycle shall be finally defined needs further discussion and coordination with the HDV-CO₂ test procedures.

The application of the PTO cycle for HDV AC systems would be in the simulation of the vehicle specific CO₂/km value⁴. The HDV-CO₂-simulator could provide the power cycle at the wheel hubs together with the target power demand of the AC system for the vehicle specific input data in the corresponding test cycle. The HILS simulator then provides the resulting trajectories for engine power and rpm, which then can be used in the HDV-CO₂ simulator to interpolate the fuel consumption from the engine fuel map (see chapter 2.3.3).

2.3 **Task 5: Development of WHVC weighting/scaling factors to represent real world vehicle operation**

2.3.1 *Task 5.1: Analysis of typical profiles for vehicle speed and propulsion power*

Driving conditions are quite different between different vehicle classes and reach from mainly urban driving (e.g. city bus) to mainly highway driving (e.g. semi-trailers). Thus the entire WHVC is representative for an average HDV but not for the single vehicle classes. To be in the position to provide vehicle class specific results, weighting factors are elaborated which adapt results from the WHVC to single HDV classes.

The European draft HDV-CO₂ test procedure defines a matrix of HDV classes and corresponding representative real world driving cycles. This set of cycles was used for the elaboration of the WHVC-weighting factors.

2.3.2 *Task 5.2: Elaboration of weighting factors for different parts of the WHVC*

The software PHEM was used to calculate power demand, engine speed, energy consumption, emissions, vehicle speed and derivatives for the WHVC and for the CO₂-test cycle representative for a HDV class. Then the WHVC-weighting factors are gained iteratively to reach the lowest deviation in the results between the weighted WHVC and the representative driving cycle. The resulting WHVC-weighting factors are then valid for the considered vehicle category.

The WHVC is split into three different sub-cycles (urban, road, motorway) and for each of these sub-cycles the weighting factor is varied between 0 and 1 while the sum of the three weighting factors has to be 1.0 and in addition the maximum deviation for every single kinematic parameter has to be in a specified tolerance range. The fundamental equation for the developed method is shown in Equation 2.

⁴ Or g/ton-km or g/m³-km,...

$$\sum_{n=Urban,Road}^{Motorway} \left(WF_{WHVC-n} \times \sum_{i=Kin.Param1}^{Kin.Param j} WF_{Ki} \times \sqrt{\left(\frac{KPi_{RS} - KPi_{WHVC-n}}{KPi_{RS}} \right)^2} \right) = KP_{Tot} = Minimum$$

With: WF_{WHVC-n} WHVC weighting factor
 WF_{Ki} Weighting factor of the kinematic parameter i
 KPi_{RS} Value of the kinematic parameter I in the representative cycle
 KPi_{WHVC-n} Value of the kinematic parameter I in the WHVC sub-cycle
 KP_{Tot} Total weighted deviation of the kinematic parameters between weighted WHVC and representative real world cycle

Equation 2: Main equation for calculating the WHVC-weighting factors

The method for the calculation of WHVC weighting factors was applied for city buses yet (Figure 6). Unsurprisingly, for the considered city bus cycle the calculated weighting factors are 100% for the WHVC urban sub-cycle, the two remaining sub-cycles are weighted with 0%.

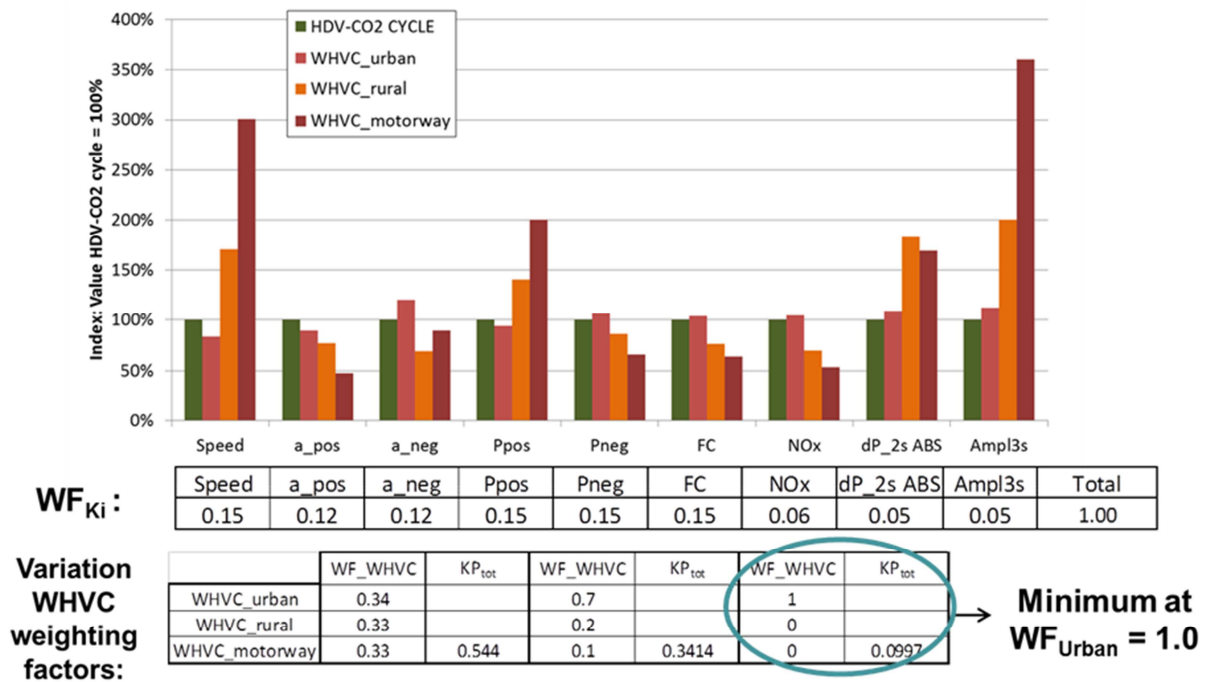

Figure 6: Calculation of WHVC weighting factors for city bus cycle

For the validation also a model of a hybrid city bus will be run in PHEM over the WHVC and in the representative CO₂ test cycle. Since the representative driving cycles for the European HDV-CO₂ test procedure are still under development, this task was only carried out for the already existing city bus cycle. As soon as the remaining cycles are available (expected until end of

2012), this task will be finalised for all cycles and an update of this chapter of the report will be made.

2.3.3 *Task 5.3: Elaboration of options to use the HILS method in the HDV CO₂ test procedure*

Test procedures for vehicle related CO₂ emissions from HDV exist in Japan, in US and in China. For the EU a test procedure is in preparation. Most of these test procedures use a simulation tool calculating the power demand from the engine to overcome the driving resistances, the losses in the drivetrain and the power demand from auxiliaries. The fuel consumption is then interpolated from an engine map. How the necessary input data (vehicle mass, air resistance, rolling resistance, engine map etc.) is measured and in which detail these test results are implemented into the simulation tool is different in the regulations and also different for the single components (from vehicle class dependent default values up to vehicle specific test data). The simulation of HDH is not installed in the CO₂ simulation tools yet since an accurate modelling of HDH would need a HILS model also for CO₂.

The main differences of the HILS method developed for the regulated pollutants against the CO₂ simulation tools are the ECUs as hardware in the loop, that the engine is measured instead of interpolations from engine maps and that generic vehicle data is used. The other parts of the simulation are similar.

Since the setup of a HILS model is quite a high effort a method was elaborated which allows the usage of the HILS model also for the CO₂ simulation. This shall also avoid that two different results for the CO₂ emissions are produced for one vehicle/power pack combination.

Two options are possible:

- 1) Using the HILS model to simulate the HDH and to simulate the same vehicle with a conventional engine in the WHVC with generic vehicle data or with the WHDHC. In both cases the fuel consumption could be interpolated from an engine map giving the [g/kWh]. Then the WHVC weighting factors are applied. The ratio between the results for the HDH and for the conventional engine could be applied as "Hybrid-Bonus Factor" for the vehicle related CO₂ emissions. Main disadvantage of this approach is that the HILS simulator needs then a subroutine for conventional HDV which most likely will be less detailed than the original HDV-CO₂ simulation tool⁵, especially in simulating auxiliaries and gear boxes. In such a case it will be questionable if the resulting Hybrid Correction Factor delivers commonly agreed ratios.
- 2) Taking the engine power and rpm course calculated by the HDV-CO₂ simulation tool as input for the HILS simulator instead of the WHDHC. The HILS simulator could then produce the torque and rpm signal for the combustion engine to interpolate the fuel consumption from the engine map. The latter could be done again in the HDV-CO₂ simulation tool to avoid influences of different interpolation methods. This method is like a

⁵ The current CO₂ models, such as the GEM model from US EPA, are also not very detailed. But it seems likely that these models will evolve to take the fuel saving potential from advanced technologies also into consideration in future. The effort to update all of these developments also in the HILS model is questionable.

bypass in the HDV-CO₂ simulation tool before the engine map interpolation (Figure 7).

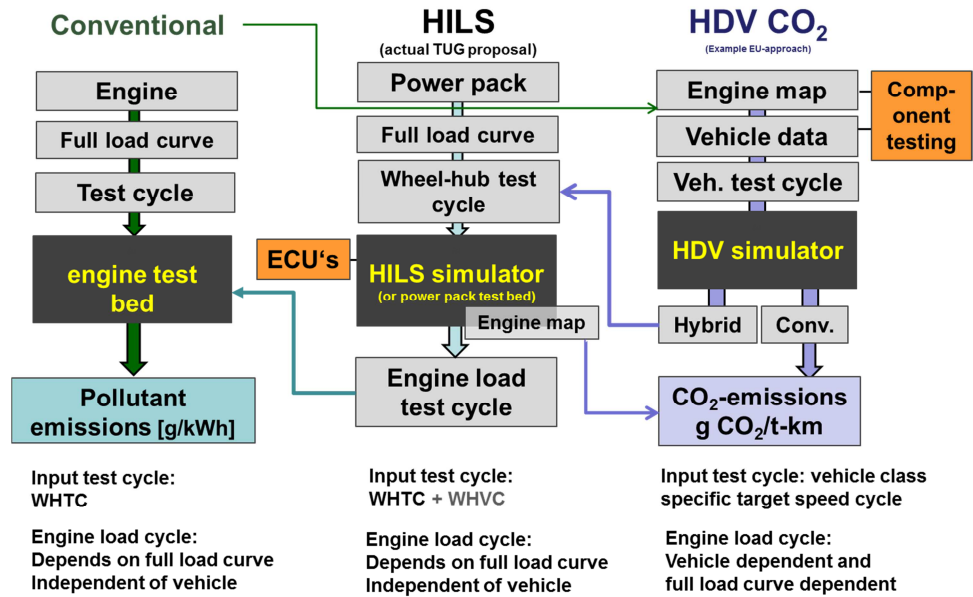

Figure 7: Option to harmonise the test procedures for pollutant emissions from combustion engines and from hybrid power packs with the CO₂ emissions from HDV

3 Detailed description of the tasks

3.1 Task 1.2: Review of vehicle-related data

As described in chapter 2.1 regulated pollutant emissions of conventional heavy duty engines are determined on an engine test bed. The engine is operated following predefined traces of rotational speed and torque which depend only on the full load curve of the engine. The parameters of the vehicle on which the engine is installed have no influence on the engine test cycle.

If a vehicle speed cycle over time is used for determining regulated pollutant emissions, as proposed in the original Japanese HILS (Kokujikan No. 281) approach, the resulting engine load cycle will depend on the vehicle parameters. Therefore, measured emissions for conventional heavy duty engines and heavy duty hybrids might not be comparable. In order to get similar load cycles for heavy duty hybrid power packs and conventional heavy duty combustion engines, a vehicle-independent alternative approach – called WHDHC (world heavy duty hybrid cycle) – for use in the Japanese HILS simulator was developed. This chapter provides additional information on how this test cycle was generated.

3.1.1 Generation of the WHDHC

Based on the hybrid power pack full load curve, the load cycle is calculated according to the WHTC method like for conventional engines. From this WHTC load cycle, a fixed fraction for vehicle drivetrain losses⁶ is subtracted to get the power cycle at the wheel hubs. To allow for charging of a hybrid vehicle's RESS (rechargeable energy storage system) during phases of deceleration, a corresponding negative power course for mechanical braking is added in the existing motoring phases of the WHTC⁷. This amended version of the WHTC is called in the following WHDHC (World Heavy Duty Hybrid Cycle). The development of the negative power course is described in the subsequent chapter.

3.1.1.1 Hybrid power pack full load curve

The application of a proper full load curve for the HDH power pack is important to obtain realistic load points in the WHDHC. A too low full load curve would exclude full load operation of the power pack in the resulting test, what would not result in a representative engine load profile for Heavy Duty Engines. A too high full load curve could result in a test cycle, which cannot be followed by the engine.

At the time being no standard exists, which describes how to define the full load curve of a hybrid power pack. Especially the potential for electric engines to run overload makes the definition complex. The possible overload against rated power is limited by the temperature of the engine and of the power electronics and thus depends on the time the overload shall be provided and also on ambient conditions, cooling capacity and on the foregoing engine load profile.

A final solution how to define the full load curve was not decided yet. The actual status is:

The full load is the maximum power the power pack can provide over short periods (~3 seconds) at single rpm steps. This would need an alternative mapping method than for the conventional engines (ECE/TRANS/WP.29/GRPE/2012/4,

⁶ Efficiencies as used in the actual Japanese HILS model (Kokujikan No. 281).

⁷ As engine test cycle the WHTC has negative power only down to the engines motoring curve.

chapter 7.4, which defines 4 to 6 minutes to sweep from minimum to maximum mapping speed).

It is open whether the full load curve shall be measured or if a calculated full load curve is acceptable.

Another important topic to be further analysed in the next project phase is the effect of the fact, that an electric motor has an “idling speed” of zero rpm while the idling speed of a HD combustion engine typically is in the range of 600 rpm. Although an electric motor has higher power than a combustion engine at low rpm, the power curve of the combustion engine is higher when plotted over the normalised engine speed (Figure 8). The electric engine would represent the motor of a serial hybrid concept. “Concept Hyb_#02” represents a parallel hybrid system which starts with the electric motor and connects the combustion engine when the idling speed of the combustion engine is reached. The rated power of the electric motor in a parallel hybrid is typically lower than in the serial hybrid where the electric motor has to provide the entire power to run the vehicle. This can be seen in the left picture up to 550 rpm.

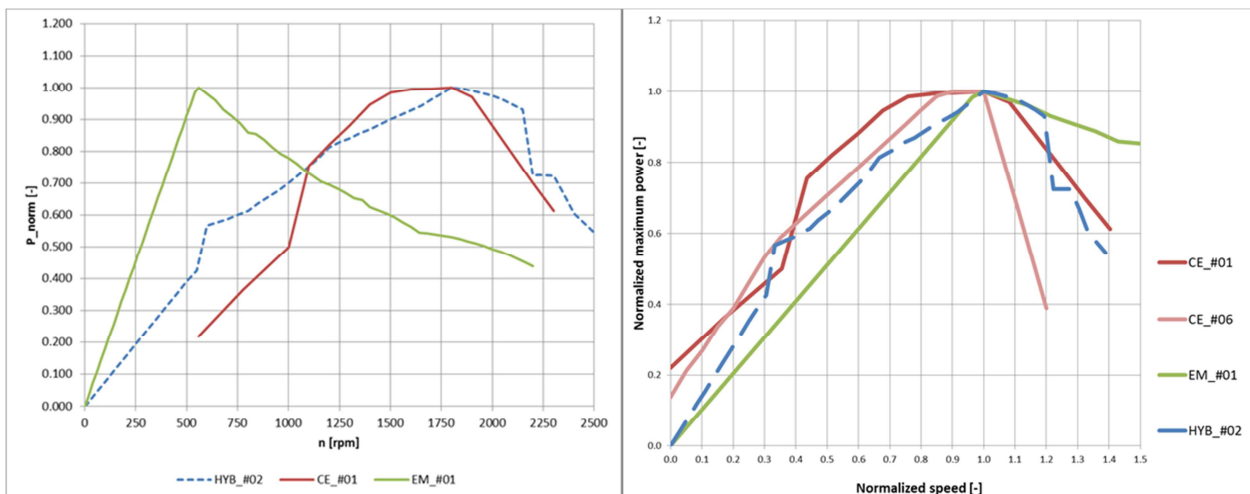

Figure 8: Schematic pictures of full load curves from different drive trains with absolute rpm (left picture) and rpm normalised between idling and rated speed (right picture)

This different characteristic influences the resulting WHTC since the idling speed is relevant for the reference speed of the WHTC de-normalisation procedure:

$$n_{\text{ref}} = n_{\text{norm}} \times (0.45 \times n_{\text{lo}} + 0.45 \times n_{\text{pref}} + 0.1 \times n_{\text{hi}} - n_{\text{idle}}) \times 2.0327 + n_{\text{idle}}$$

Since also the torque curve at speeds above the maximum power is quite different for electric motors and for combustion engines, the effects on the computed WHDHC need to be considered. A first analysis showed rather low differences. Figure 9 compares parts of the WHTC calculated from the full load curves shown before. The combustion engine with high torque at partial load has the highest power over the WHTC. Within the other three engines the electric motor tends to have higher power in the WHTC.

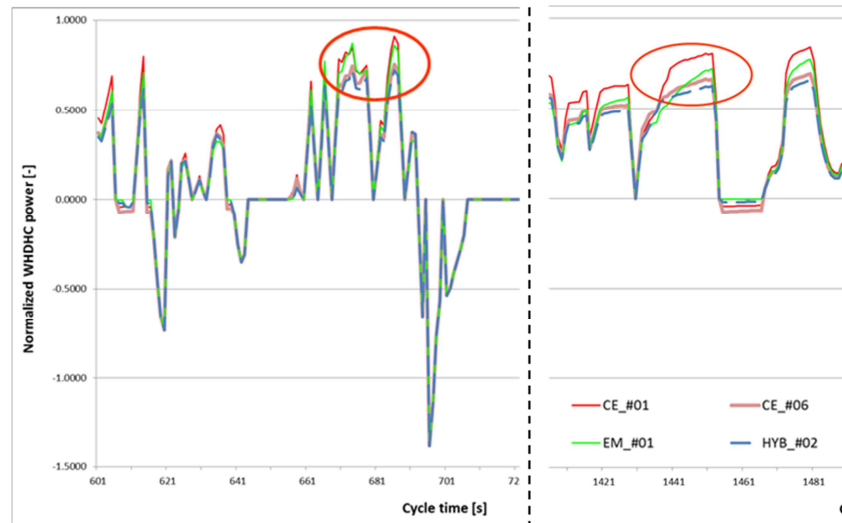

Figure 9: Comparison of the WHTC's resulting from full load curves from different drive trains shown in Figure 8

Since HDV are typically accelerated from low engine speeds with full open throttle position, the results for the WHTC seem to be plausible also for electric engines (i.e. if the engine delivers less power at a given speed, the driver is using less power). For a validation of this thesis data from in-use city bus tests in the cities of Vienna and of Graz were available. Since the engine torque was not measured in these tests the power at the wheels was computed from the driving resistances and from the road gradients similar to the HILS model. Figure 10 shows as example the distribution of acceleration and of power in 1 Hz resolution from tests at a Volvo Hybrid bus and at a conventional EURO III Evobus in Graz. The hybrid bus had lower torque at low engine speeds than the conventional bus and showed also lower maximum values in acceleration and driving power.

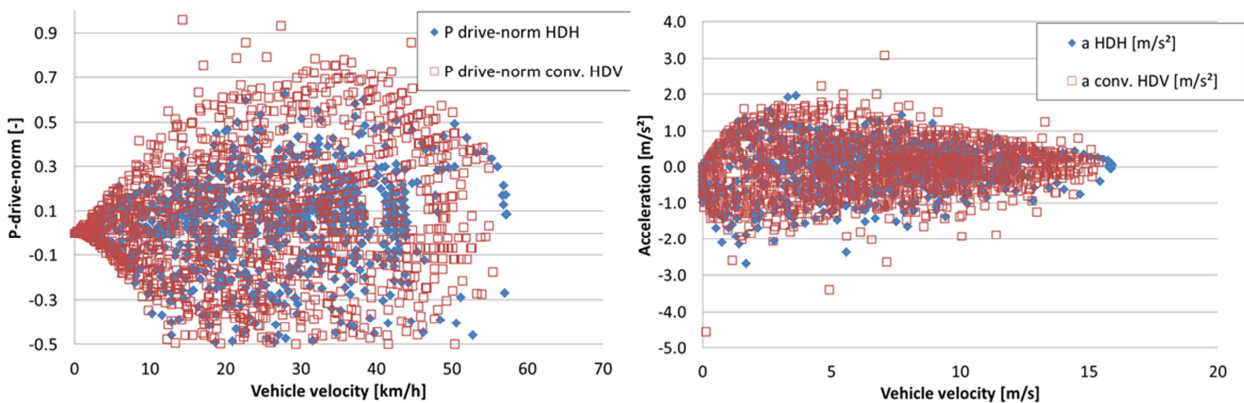

Figure 10: Comparison of power distribution and of acceleration for a conventional bus and for a parallel hybrid bus over three routes in the city of Graz

These findings support the option to apply the WHTC de-normalisation process also at serial and parallel power packs to create the basis for the WHDHC. A more in depth validation would need more detailed test data. Such data may be available in the next project phase when the HILS method will be applied on two HDH. However, this would need tests with the entire hybrid vehicle and with a comparable conventional vehicle on the same route with the same driver and under similar traffic conditions to enable a founded comparison of the differences in the engine

load in the WHTC and in real world driving. In any case it is suggested, that OEMs apply the tool developed for the calculation of the WHDHC for HDH power pack systems and compare the resulting test cycle with the cycle gained for conventional engines with similar rated power. This work is reserved for phase two of the project since no full load curves for HDH power pack systems were made available within phase 1.

3.1.1.2 Negative power for the WHDHC

Since the WHTC cycle is defined in normalized rotational speed and torque traces, also a corresponding normalized negative power (mechanical braking and engine motoring) course representative for all vehicle categories had to be developed. For this task real world driving data for several city buses in Vienna were analysed. Based on the respective full load curve the positive cycle work in the WHTC was calculated. The vehicles were also simulated in the urban part of the WHVC and different routes in Vienna according to the collected data with the software PHEM. Since the ratios between the positive work of different vehicles in the WHTC (see Figure 11) depend on the full load curves of the vehicles, the corresponding negative power in real world operation should follow a similar distribution if dependent on the shape of the specific full load curves. But the analysis showed that the corresponding negative power in real world operation follows the distribution simulated for the urban part of the WHVC which is not related to the vehicles full load curve (see Figure 12). As a consequence the corresponding negative power cycle for the WHDHC is normalized with the vehicle's rated power.

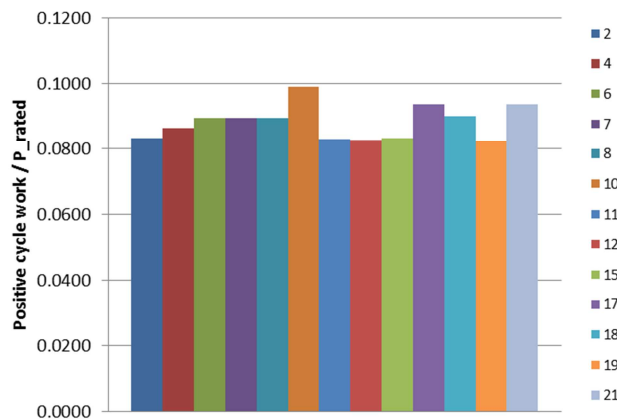

Figure 11: Normalized positive cycle work in WHTC for engines of different HDV's

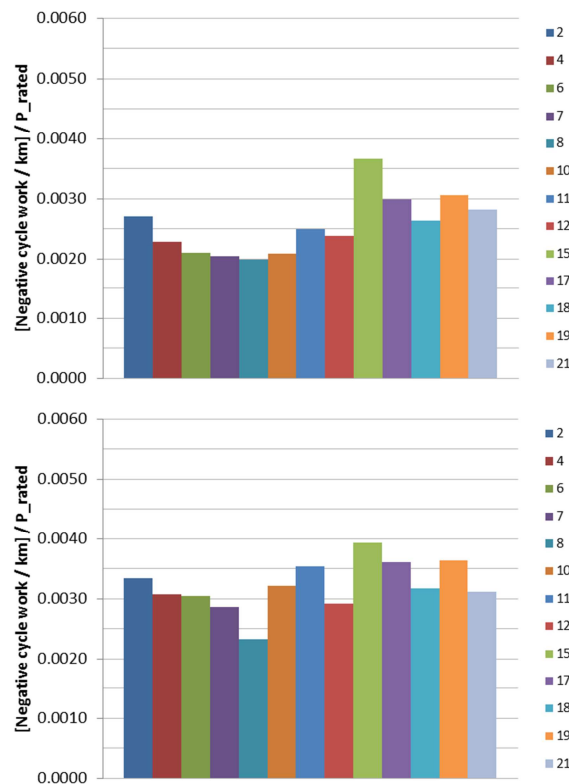

Figure 12: Normalized negative cycle work in WHVC (left) and on city routes in Vienna (right) for different HDV's (engines as in Figure 11)

The normalized positive cycle work in Figure 11 is the integral positive engine work over the whole test cycle divided by the engine rated power, the normalized negative cycle work in Figure 12 is the integral negative work (i.e. engine motoring torque and mechanical braking) over the whole cycle divided by the total cycle length and the vehicle rated power.

In order to define a universal normalized negative power trace, 13 generic heavy duty vehicles according to HBEFA 3.2 were simulated in the WHVC with the software PHEM and the resulting absolute values for negative power were normalized by each vehicle's rated power (see Figure 13). From these specific normalised results an average normalized negative power course was calculated (labelled "Average" in Figure 13).

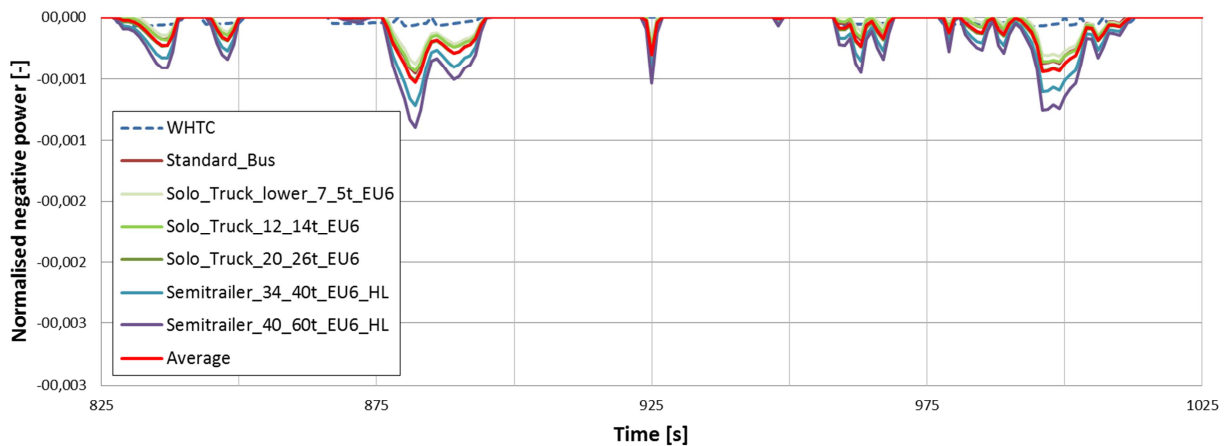

Figure 13: Normalized negative power trace for different vehicles in the WHVC (normalisation by division by the power pack rated power resulting in the unit kW/kW_{rated_power})

The average normalized negative power trace for the “average vehicle” in the WHVC is defined as:

$$P_{neg, norm, average}(t) = \sum_{i=vehicleNo.1}^{13} \frac{P_{neg, norm, i}(t)}{13} \quad [\text{kW}/\text{kW}_{\text{rated-power}}]$$

Figure 13 shows significant differences in the normalised negative power for the different HDV categories. The analysis of these differences showed a clear dependency on the vehicle size class. Long haulage vehicles for example have lower air resistance per ton vehicle mass. The mass is corresponding at deceleration events to the inertia force ($m \cdot a$) in driving direction. The air resistance is a force against the driving direction. Therefore, vehicles with a high ratio of mass to air resistance need more normalized mechanical braking (see Figure 13). To improve the fitting of the normalised negative power to different HDV size classes a vehicle size dependent correction factor is necessary. Since the resulting test cycle shall be independent from vehicle specific values, the vehicle mass and the air resistance are no suitable parameters for correction factors. If vehicle specific parameters are included, different test cycles would be computed even for each different version of a driver cabin mounted at a HDV model. This seems to be an inadequate high test burden for HDH power pack systems compared to conventional engines. Since on average the engine rated power mounted in a HDV is correlated to the vehicle mass⁸ the rated engine power was used for the correction factor instead of the vehicle specific parameters.

By calculating the line of best fit for the average normalized negative power over the cycle of all analysed vehicles (see Figure 14) a correction factor depending on the vehicle rated power was calculated. Based on the average of all simulated vehicles represented by the red square in Figure 14 and the equation for the line of best fit the correction factor for the average trace of negative power (P_{Rated_Factor}) was calculated according to Equation 3.

⁸ i.e. the heavier vehicle the higher the rated engine power.

It shall be noted, that the P-Rated-factor is dimensionless since it has the actual rated engine power in the numerator and the rated engine power of the average vehicle (i.e. 265.57kW) in the denominator.

$$P_Rated_Factor = \frac{-0.000158 \times P_{rated\ Powerpack}}{-0.000158 \times 265.57} = 0.003765 \times P_{rated\ Powerpack} \quad [-] \quad ^9$$

Equation 3: Calculation of the P_Rated_Factor

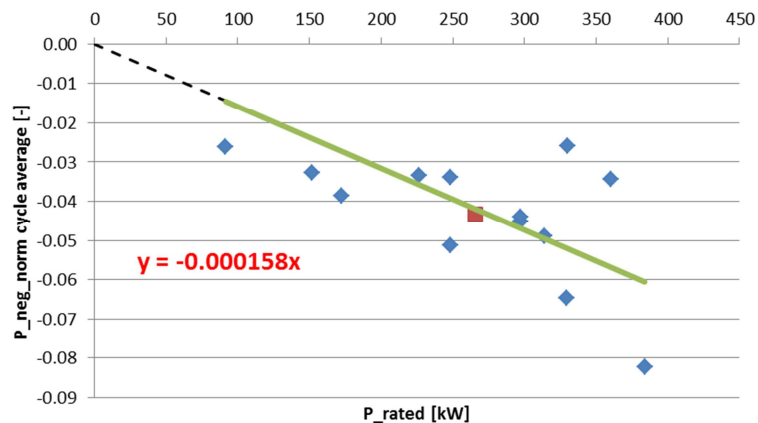

Figure 14: Dependency of normalized negative power trace on vehicle rated power

The average normalized negative power trace shown in Figure 15 as well as in Figure 13 has to be multiplied by this correction factor and by the vehicle's rated power to get the absolute negative power over time for one particular vehicle in the WHDHC (see Equation 4). Figure 16 illustrates the difference between the uncorrected average trace and the corrected trace in comparison to the original trace simulated for one specific vehicle.

$$P_{negative\ WHDHC}(t) = P_{negnormaverage}(t) \times P_Rated_Factor \times P_{rated\ Powerpack} \quad [kW]$$

Equation 4: Calculation of absolute negative power in WHDHC

⁹ The P_Rated_Factor represents just the ratio of the "normalised negative power" of the vehicle under consideration to the normalised negative power for the average vehicle. Normalised negative power does mean here the average negative power over the entire WHVC.

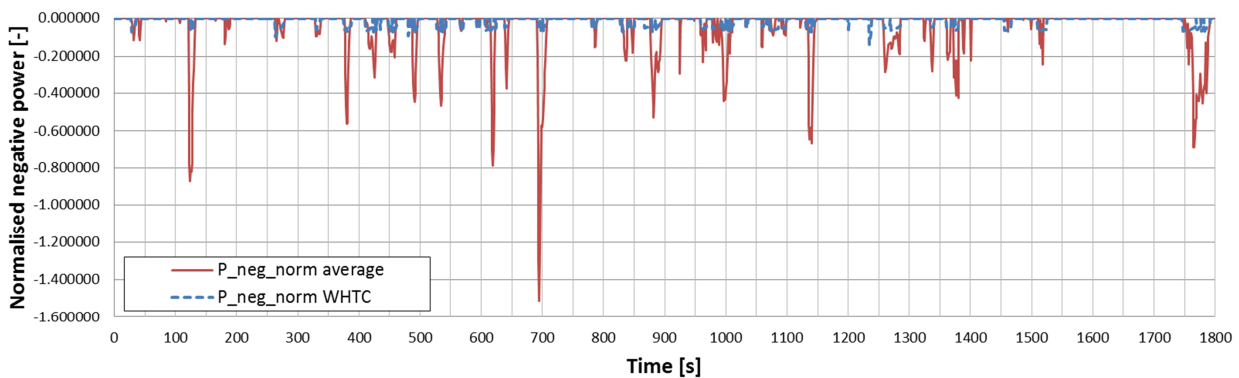

Figure 15: Average normalized negative power (P/P_{rated}) in the WHVC vs. normalized negative power in the WHTC

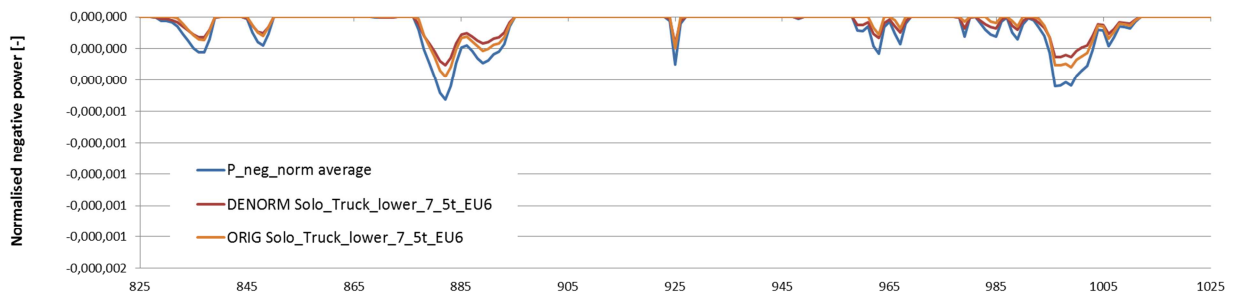

Figure 16: Original (labelled ORIG), corrected (labelled DENORM) and average normalized negative power trace exemplarily for one specific vehicle

3.1.1.3 Interface of WHDHC and HILS model

A Microsoft Excel tool was developed to automatically calculate the complete WHDHC test cycle as described in the previous chapters for a given full load curve of a particular hybrid power pack. As listed in chapter 2.1 there are different options to feed the WHDHC into the Japanese HILS model. All of these options are calculated automatically in the developed Excel tool.

For option B3 the WHVC as vehicle speed cycle is used as input with individually calculated road gradient cycle, vehicle mass, air resistance and driving resistance data to create the same power cycle as the WHDHC at the wheel hub. To get vehicle independent parameters for the calculation of driving resistances, an equation depending on the vehicle rated power was determined by the line of best fit for the data of the same 13 generic heavy duty vehicles according to HBEFA 3.2 mentioned in the preceding chapter. With these assumed vehicle parameters the power for acceleration, rolling resistance and air resistance is calculated over the WHVC and compared to the power of the WHDHC. The difference in power between these two cycles is compensated by calculating a corresponding road gradient course. The result is the WHVC speed cycle with specific vehicle parameters and a specific road gradient course which serves as input for the HILS simulator and leads to identical power traces at the wheel hub as the WHDHC (see Figure 17).

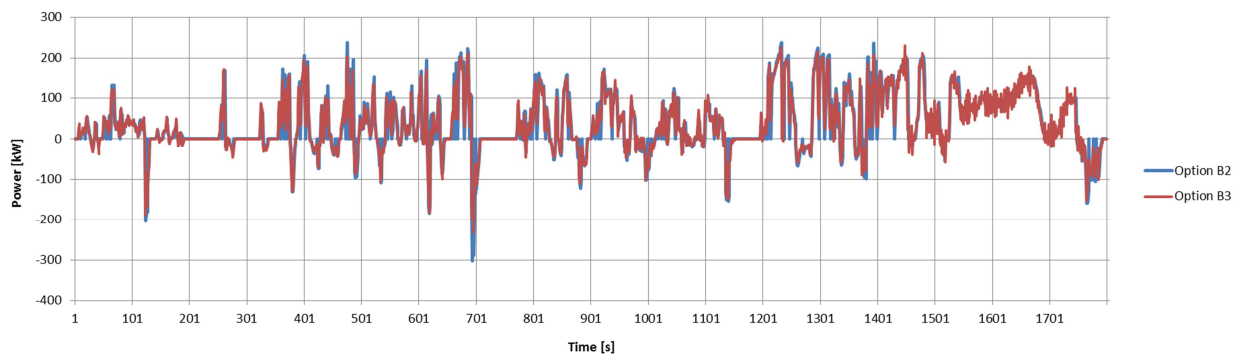

Figure 17: Power at wheel hub for WHDHC option B2 (direct calculation) vs. option B3 (calculation via WHVC)

Option B3 was tested with the vehicle data sets from HBEFA. Reasonable vehicle parameters and similar road gradients over the WHVC were computed for all vehicle categories. Further testing of the method shall be performed in combination with the HILS simulator in the next project phase. One issue with option B3 is that this approach leads to rather high values for the road gradient in short phases of the cycle (Figure 18). For ECU's which have intelligent loops to control the demanded power this may lead to problems when using this cycle as input in the HILS simulator.

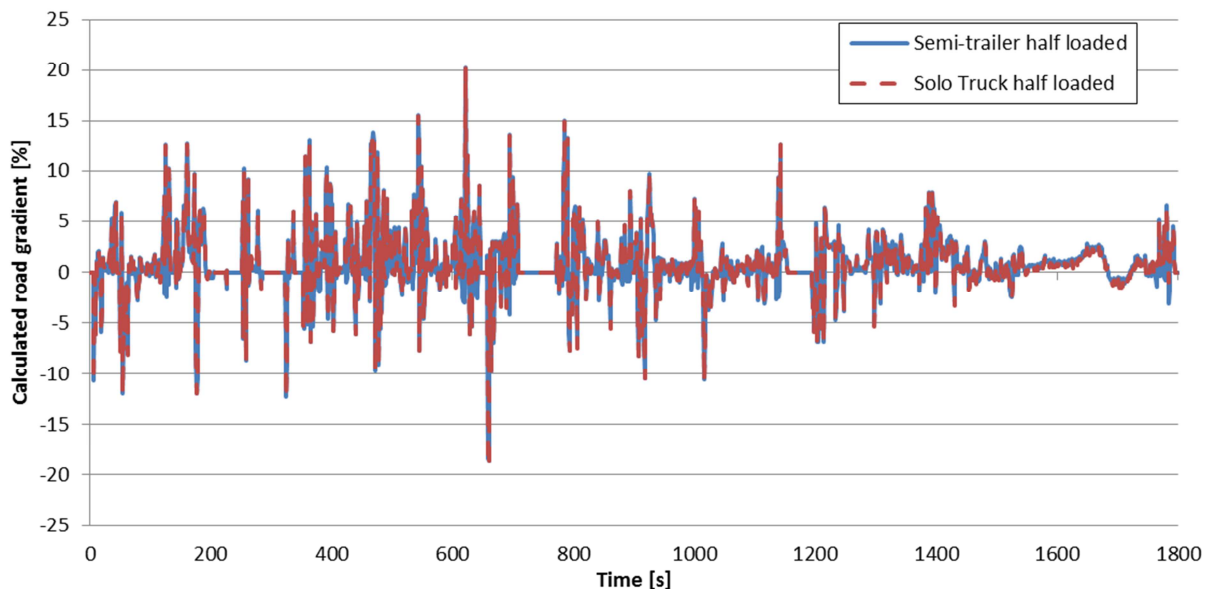

Figure 18: Road gradients to be simulated in the WHVC meet the WHTC power course exactly in option B3

Therefore the resulting change in cycle characteristics when limiting the road gradient to levels of $\pm 6\%$ and $\pm 10\%$ was analysed. According to Figure 19 the power trace of the vehicles simulated with the software PHEM in the WHVC still follows the corresponding direct wheel hub power trace quite well. Figure 20 illustrates the frequency distribution of normalized cycle power for the directly calculated WHDHC (wheelhub cycle) and the corresponding WHVC (speed cycle) with and without limitation of the calculated road gradient values. This distribution shows nearly the same characteristic as the original curve when limiting the road gradient. Furthermore the number of full load points that occur over the different

speed cycles was analysed. Here, too, no significant change was found when limiting the road gradient. Therefore the limitation of the calculated road gradient to +/-6% with regard to the mentioned problems with ECU monitoring functions was identified as a viable option.

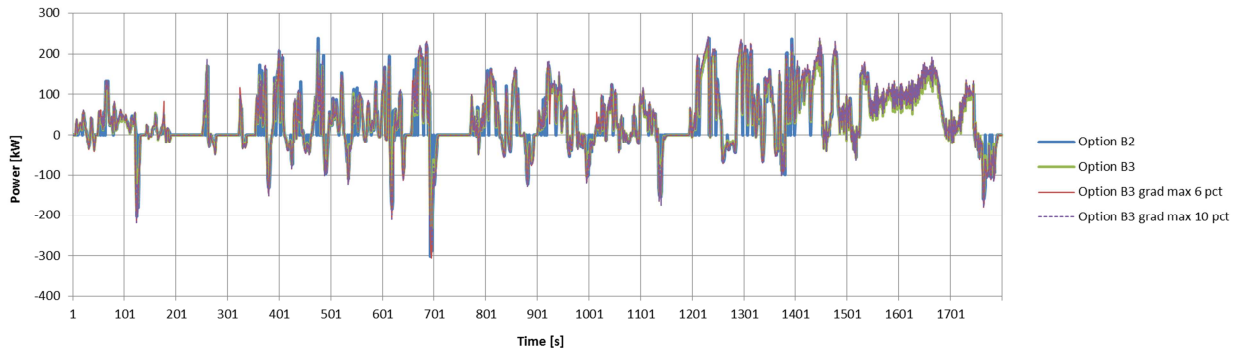

Figure 19: Power at wheel hub for WHDHC option B2 (direct calculation) vs. option B3 (calculation via WHVC) for different maximum road gradients

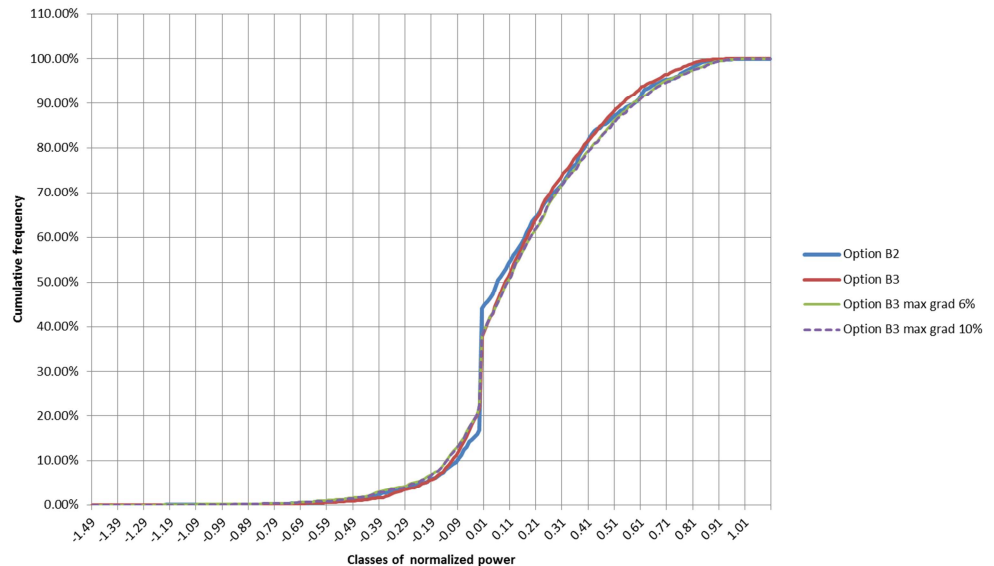

Figure 20: Frequency distribution for normalized power for WHDHC option B2 (direct calculation) vs. option B3 (calculation via WHVC) for different maximum road gradients

3.2 Task 4: Inclusion of PTO operation

A PTO is typically a driveshaft which is designed to take power from the power pack of the vehicles power source. On trucks the PTO can typically be ordered separately and is mounted to the transmission. The PTO can be linked to the transmission mechanically, by air valve or by hydraulic systems. Which devices are connected to the PTO is usually beyond the influence of the vehicle manufacturer. Typically a hydraulic pump is driven by the PTO since the hydraulic system allows transmitting the power to any location at the vehicle. The hydraulic power can then be used e.g. to operate the compactor of a garbage truck, a water pump on a fire truck or a winch on a truck crane.

If and how PTOs could be considered in the HILS type approval method for HDH was analysed in this project. In this chapter background information to chapter 2.2 is given.

3.2.1 Task 4.1: Options to simulate PTO power demand

PTO power demand can basically be simulated following two approaches:

- Define the “useful work, P_{use} ” to be delivered by the device operated at the PTO (e.g. the P_{use} of a winch over time in a test cycle = $m * g * \Delta h / \Delta t$) and demand the efficiency of the device as input parameter. The efficiency of a system like a winch would be defined by the mechanical efficiency of the winch and a map of the efficiency of the hydraulic system. With this input data the mechanical torque and speed at the transmission can be simulated over the test cycle.
- Define the mechanical power demand of a PTO (P_{PTO}) at the transmission directly and define the transmission ratio to the engine to allow computing the torque and speed.

Option a) is a reasonable approach if the test procedure shall assess also the efficiency of the hydraulic system and of the device connected to the PTO. This is not the case when an engine test cycle for regulated emissions of the power pack of a HDH shall be derived. Thus option b) is recommended since it seems to be the simplest but still sufficient approach in a simulation tool. The mechanical losses of the transmission to the PTO can be included into the PTO power demand cycle, then the power from the PTO can be simply subtracted from the power delivered by the engine. This approach fits into the forward calculating driver model of the Japanese HILS simulator. The power after PTO (P_{out}) is just the input power minus P_{PTO} .

$$P_{out} = P_{in} - P_{PTO}$$

From the power the torque transmitted to the driven wheels can be computed which is then necessary to simulate the resulting acceleration or deceleration of the vehicle (Figure 21).

$$M_{out} = M_{in} - M_{PTO} \times \frac{\omega_{PTO}}{\omega}$$

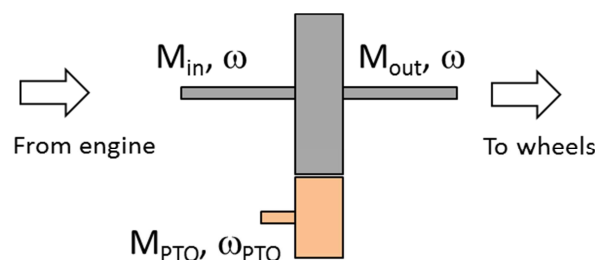

Figure 21: Schematic picture of the recommended interface of the transmission of a HDH power pack to a PTO power demand.

If the PTO is driven by an electric engine the resulting electric power needs to be calculated by the engine efficiency map. This power demand needs then to be connected to the battery model in the HILS simulator.

If PTO operation should be simulated in the HILS simulator, the main challenge will be to define a standardised interface where P_{PTO} has to be subtracted in the model

since the location of power take off may differ significantly (mechanical or electrical power, high or low Voltage circuit, etc.).

Beside the problem to define the interface in the model also P_{PTO} has to be defined. For this task the aforementioned option a) could be used to transfer measured “useful work” from PTO devices into a power demand at the PTO (see chapter 3.2.3.).

Even more important than interface and test cycle is to identify reasonable options, how the power demand from PTO may be used in the process of elaborating an engine test cycle for HDH. This task is described in chapter 3.2.2 below.

3.2.2 *Task 4.2: Options to transfer different engine work into a benefit system*

The additional work demanded by PTO over the test cycle is assumed to be in the range of 2% to 10% in typical mission profiles of vehicle categories where PTO have relevant influence on the total positive work delivered by the engine.

The method to include PTOs should result in some benefit for the HDH power pack if it uses the energy more efficient than the conventional engine.

The HILS method would be capable of simulating the engagement of electric motor, of a generator and of the combustion engine also when a power demand from a PTO is virtually added in the model.

The WHTC for conventional combustion engines does not include any PTO power demand in its power course. Thus a straight forward approach which would simply include PTO power for conventional and also for HDH propulsion systems is problematic since an adaptation of the WHTC cycle would be needed. Otherwise adding a power demand for PTO operation only to the HDH test cycle but not to the WHTC would not be a benefit for hybrid systems.

To test the potential influence of an additional power demand at PTO in the WHTC, the simulation tool PHEM from TUG was engaged with the generic EURO V data set developed for the HBEFA V3.1 ([2] and www.hbefa.net). The results showed very low influence on the resulting engine work based emissions [g/kWh]. Figure 22 shows results for fuel consumption, and raw NO_x emissions which varied between -2% and +1% with variations of the positive cycle work between -8% and +11%. The sensitivity of different engines may be different but in general the emissions in [g/kWh] are expected not to vary very much if the load cycle is changed within reasonable boundary conditions.

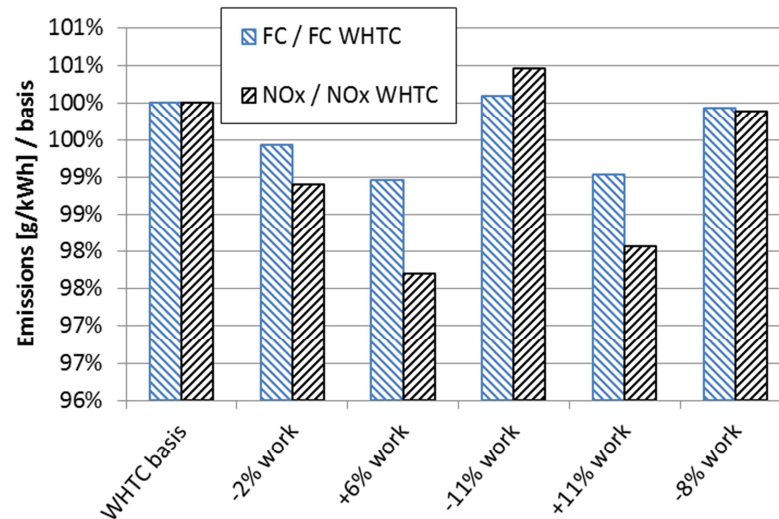

Figure 22: Simulation results for a generic EURO VI engine in the WHTC and in “WHTC-alike” cycles with slightly modified power course to test the influence of eventual PTO’s in the test cycle

Alternatively to an adaptation of the WHTC also the HDH test cycle (WHDHC) could be adapted by just reducing the load cycle by a constant value to have then room to simulate an additional PTO power demand. Since the WHTC has zero load at idling, also the resulting WHDHC has zero load at idling. Hence, a “PTO reduction factor” cannot be applied where it should be applied for many HDV categories, i.e. at idling. Otherwise the basic simulation “without PTO” would run idling conditions at negative engine loads and would also not reach full load at other driving conditions. PTO benefits could be based also on a “PTO-benefit-factor”. The HILS model could be run with and without PTO power demand to compute the additional work consumed by the PTO. To obtain the benefit-factor the same simulations would be necessary for the conventional power train system. The benefit factor could then be the ratio of additional engine work due to the PTO in the HDH power pack to the additional engine work due to the PTO the conventional system. Such a correction factor could be applied to the measured emissions¹⁰. However, since it is unlikely, that the regulated pollutant emissions in [g/kWh] change proportionally to the engine work, this method will not lead to founded results for NOx, PM, PN, HC and CO but just to incentives to optimise the PTO connection to the hybrid system. Therefore such an approach is only reasonable if the absolute emissions [g/h] or [g/km] of a vehicle are under discussion. In absolute units a reduced engine work reduces also the fuel consumption and the CO₂ emissions.

→ **As a result of the investigations it is not recommended to consider PTO in the HILS method for the calculation of the engine test cycle for the regulated pollutants in [g/kWh].**

The situation is different for CO₂, if the measurement unit for CO₂ is [g/km] or [g/t-km] or similar. For energy consumption and CO₂ small improvements are already relevant and in addition the test methods for CO₂ from HDV are still under development and may be adapted more easily than the WHTC. Beside PTO also power demand from auxiliaries which are not engaged in the engine test procedure could be added as consumers in the HILS model. However, each additional

¹⁰ $[\text{g/kWh}]_{\text{corr}} = [\text{g/kWh}]_{\text{measured}} * \text{PTO}_{\text{benefit factor}}$

component increases the complexity of the simulation model and will make an adaptation to specific makes and models more complicated. Therefore only relevant PTO and auxiliary units should be considered.

→ **Auxiliaries and PTO with reasonable share in the entire CO₂ emission from the HDV fleet could be included into the HILS model for simulation of energy consumption and CO₂ emissions on a [g/km] basis**

Assuming that the HILS simulator will be applied also in context with the HDV-CO₂ test procedure to simulate the fuel consumption (or just the engine power and rpm course, see chapter 3.3.2), the CO₂-test cycle for conventional and for hybrid vehicles could include a power demand for PTO for the vehicle classes where PTO operation is relevant.

Following the approach from US EPA 40 CFR 1037.525 for CO₂ emissions a “benefit factor” could also be obtained by measurements instead of simulation. The approach was presented by US EPA in Working paper N° HDH-07-09 [3] which is discussed also in the next chapter when PTO test cycles are shown. The benefit factor could be applied to the absolute emission units also and could replace the simulation in the HILS model.

3.2.3 *Task 4.3: Collection of data for one vehicle mission profile*

The PTO-cycle could be defined as course over time and distance together with the vehicle speed and the road gradient as discussed in chapter 2.2. Vehicle classes with relevant PTO operation are e.g.:

- Refuse trucks (compression work)
- Municipal utility (e.g. road sweepers)
- Construction (e.g. work of a crane)
- *City bus (air conditioning system)*

The basic method to handle the test cycles which include PTO operation was discussed before. In the following possible test cycles for refuse trucks and for the air conditioning system of a city bus are described. Although an AC system is not a PTO, the AC system of a city bus was selected since it is an important auxiliary in this HDV category. Important auxiliaries may be treated in the test procedure similar to important PTO devices.

3.2.3.1 *Refuse truck*

As described in the Working paper N° HDH-07-09 [3], the US EPA commissioned Southwest Research Institute (SwRI) to study the potential applications for hybrid PTO vehicles in industry and to determine what typical PTO operation would be. The SwRI obtained a utility truck and a refuse truck, instrumented them, and sent them to their owner for field operation. The refuse truck was operated for a week on a variety of routes. The utility truck was operated for two weeks in two different locations.

- The refuse vehicle was a class 8 residential vehicle with an automated side-load-arm (SLA). This vehicle was owned by a large refuse company.
- The utility vehicle was a class 8 vehicle with a bucket. This vehicle was in a rental fleet during testing.

The testing showed that the utility truck had different duty cycles depending upon the operator and location of the vehicle while the refuse truck duty cycle was similar day-to-day for the routes it covered. SwRI analysed the data and used cluster analysis to determine the most appropriate pump operation modes based upon the data for both vehicles. Two sub-cycles were developed, one for utility and one for

refuse operations. These were combined into one cycle, weighted for time within the cycle based on unit sales. The resulting PTO cycle is shown in Figure 23.

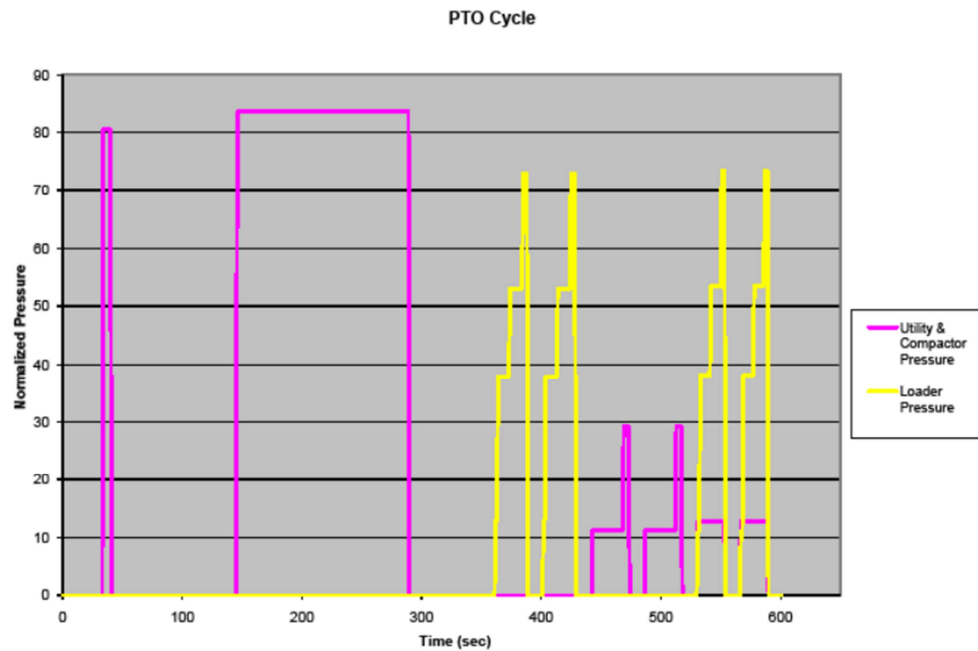

Figure 23: PTO cycle from EPA according to Working paper N° HDH-07-09

To implement such a test cycle into the HILS simulation, the PTO power demand needs to be supplemented by an appropriate vehicle speed profile. If brake energy is stored by the HDH system which could be used partly to operate the PTO, e.g. by a hydraulic system, the ratio of PTO operation and braking energy needs to be representative for real world operation. Such a “refuse truck cycle” may be extracted from the SwRI data if needed in future. Since it is not decided yet, if such a refuse truck PTO cycle will be used in future in the HILS approach, a first estimation of the feasibility of such a cycle on basis of the WHVC was performed from data in (Bach, 2003).

In (Bach, 2003) typical mission profiles of refuse trucks in the area of the city of Graz were recorded with GPS. Additionally each event of loading and compression of waste was recorded. On the chassis dynamometer for HDV of the TU Graz a refuse truck was then measured in a typical cycle also with loading of waste. The fuel consumption during vehicle idling but with loading and compressing was reported with 3.7 kg/h. This corresponds to approximately 10 kW power for PTO. In the real live missions the recorded average distance between stops for collecting waste was 125 metres with a total of 35 km. Then 120 km had to be driven to the waste deposit and back to the collection tour. Over the entire mission this results in 1.8 stops per km for waste collection. This data could be transferred into a cycle for P_{PTO} for refuse trucks in the HILS model. If the PTO test cycle shall be based also on the WHVC, almost all idling phases have to be used to simulate waste collection. In longer idling phases the collection of more than one refuse bin has to be simulated to have over the entire WHVC a representative number of PTO operation (Figure 24). This results in 29 PTO activities in the WHVC, i.e. on average in 1.4 PTO activations per km. Additional phases of compactor running may be added also during vehicle driving time.

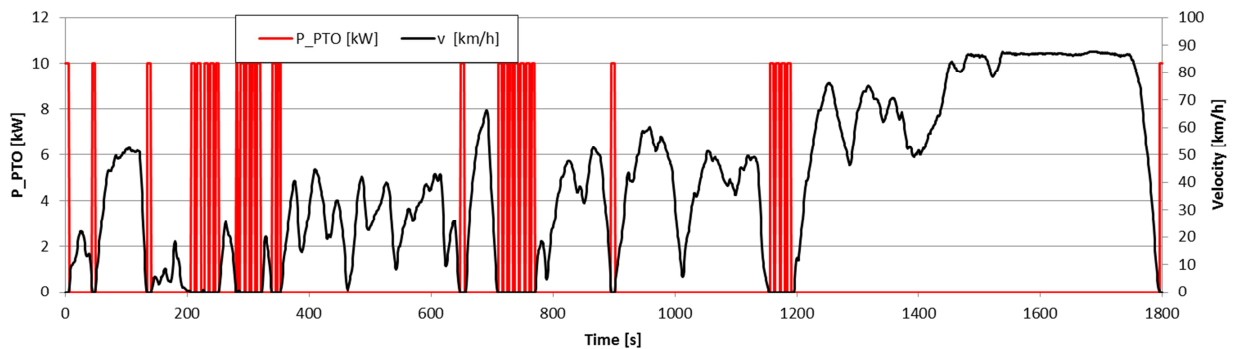

Figure 24: Schematic picture for the option of a “P_{PTO}” cycle for refuse truck operation added to the WHVC

3.2.3.2 Air conditioning system in a city bus

Although the air conditioning system of a city bus is not a PTO operation¹¹, it is discussed here since it is assumed to be a quite important device for HDH. Auxiliaries not operated at the engine test stand during type approval testing of the engine are in general not considered in the actual HILS method. Thus relevant auxiliaries shall be discussed together with PTOs since both can be simulated by adding a power consumer in the simulation tool. Similar to PTO's the HVAC system of a city bus can have a considerable share in the total cycle work. Depending on the ambient conditions and on the comfort settings the HVAC system can demand 0.5 up to 20 kW power (Working Paper No. HDH-09-06).

The power demand of the entire HVAC system covers:

- Power for the compressor in the coolant circuit (mechanical connected or with electric motor)
- Power for the blowers (usually electrically driven)

The power demand of the HVAC system depends on:

1. Ambient temperature and humidity
2. Target temperature in the cabin
3. Sun radiation
4. Area and quality of glazing
5. Air mass flow through AC system and % recirculated air
6. Technology of the air conditioning system

The influencing factors 1 to 3 shall be defined for reasonable average conditions. The factors 4 to 6 could be set as “generic” values to define actual technology. The factors 1 to 4 define the necessary cooling capacity. The factors 5 and 6 define the power demand of the HVAC system. The COP (Coefficient of Performance) value of an AC system is the ratio of cooling capacity to input power demand. Since a measurement campaign in a city bus hardly can cover average conditions for all above mentioned ambient weather data, a possible approach is the simulation of the AC system to obtain a power demand cycle (P_{AC-bus}). For this purpose an existing model from a project for DG Enterprise (Hausberger, 2010) was adapted to simulate the AC system of an average 2 axle city bus. To validate the

¹¹ it is not operated at a PTO interface at the transmission

results measurements have been performed on a Volvo 7000 Hybrid city bus in the city of Graz. In these measurements the power demand of the AC system was measured on different bus routes in the city of Graz.

3.2.3.2.1 Measurement of the mobile air conditioning on a city bus

In April 2012 the power consumption of the MAC units of a hybrid city bus, make Volvo 7700, was measured over two days in real world bus route operation. This bus type is equipped with three electrically powered MAC on the cabin roof. The AC system is make Spheros and Sütrak, with following data:

Maximum thermal cooling power $P_{cool,max} = 11.5 \text{ kW}_{th}$; operating voltage $U = 24 \text{ V}_{DC}$, max. electrical power consumption $P_{el,max} = 4.4 \text{ kW}_{el}$; working fluid R134a, working pressure 25 bar.

At running ICE the AC is powered by the mechanically driven alternator, during electric driving and standstill the necessary power is converted from the 600 V circuit, which is fed by the Li-Ion traction battery. The arrangement of the components is shown in Figure 25.

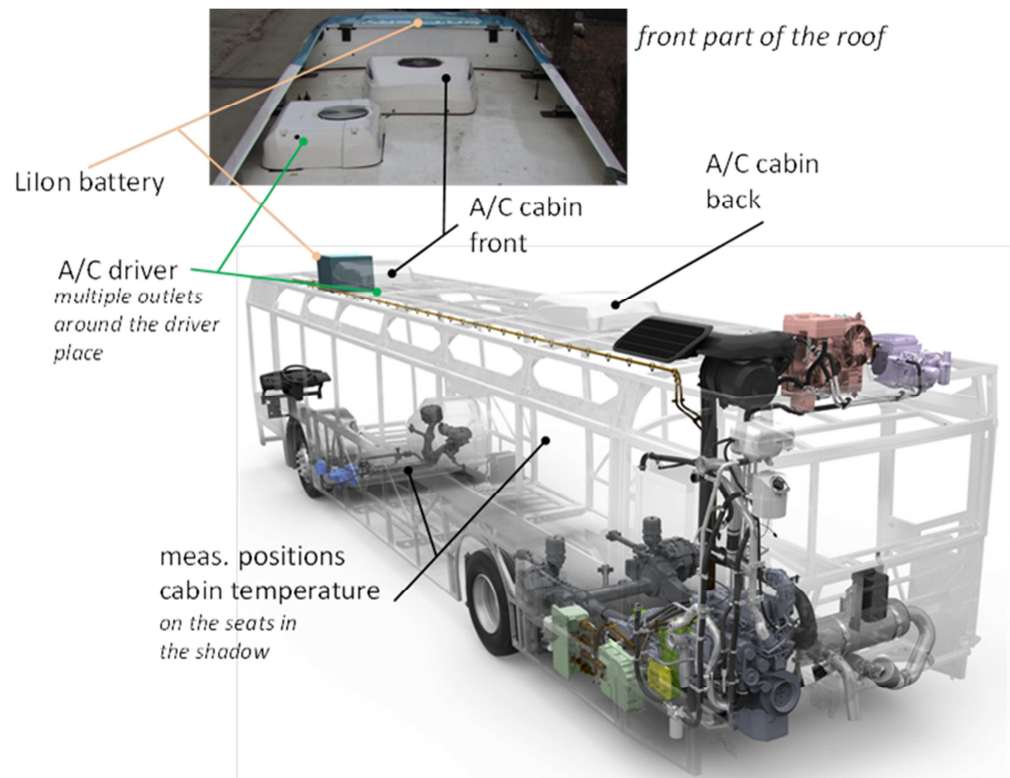

Figure 25: MAC components and measurement at the Volvo 7700 hybrid (construction picture: Volvo)

The electric power consumption of the MAC, including compressor, blower and control, was calculated by the measured current signals. In addition the outlet temperature of the cabin vents and the cabin interior temperature were recorded. Figure 26 shows as example the setup of the current measurement at one of the cabin ACs.

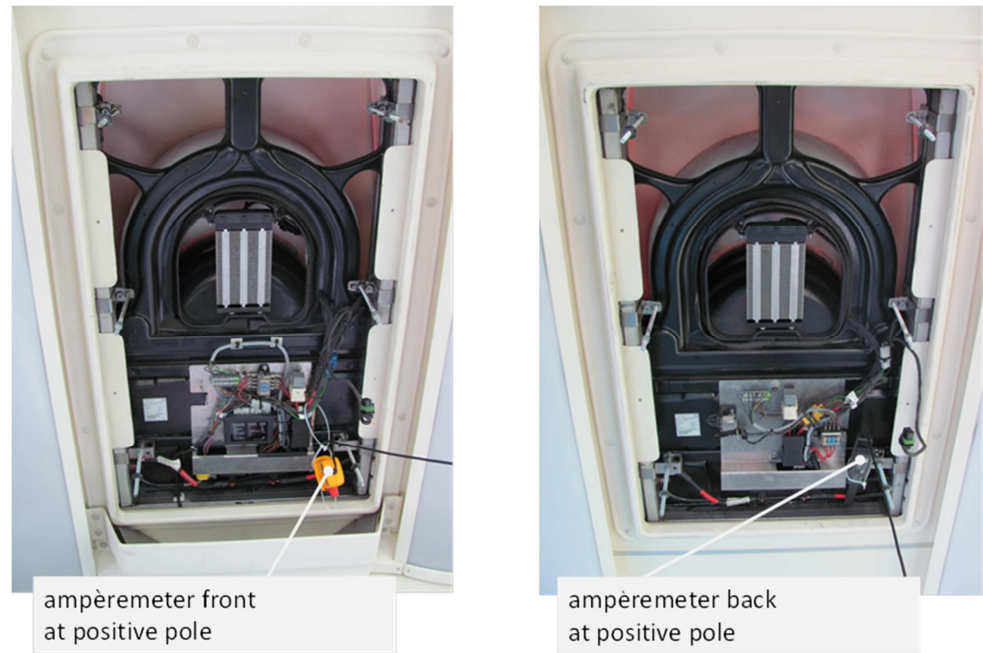

Figure 26: Current measurement of the cabin AC

To complete the measurement, the relevant weather data from the meteorological station at Karl Franzens University Graz were synchronized to the mobile data records, and all data were averaged in the single measurement periods. The location of the meteorological station which delivered the ambient conditions and the solar radiation is shown in Figure 28. The maximum distance to the actual bus position is 6.4 km. Due to cloudy weather conditions the recorded sun radiation is not fully representative for the actual heat load at the bus cabin. For these reasons the measured data was averaged over seven trips of the bus. The average ambient temperature was 21.1°C at 51% relative humidity with 556 W/m² sun intensity (varying between 365 and 732 W/m²), see Table 1. The “heat entrance” from sun radiation listed in Table 1 was calculated from sun radiation and from glazing size and quality with a simulation tool described in [4] for passenger cars. Saint-Gobain developed this tool which calculates transmission and heat transfer as function of type, installation angle and size of each glass installed in a vehicle. The calculation is based on a balance of transmission and reflection from radiation and the resulting glass temperature with corresponding heat transfer to ambient and to the cabin (Figure 27).

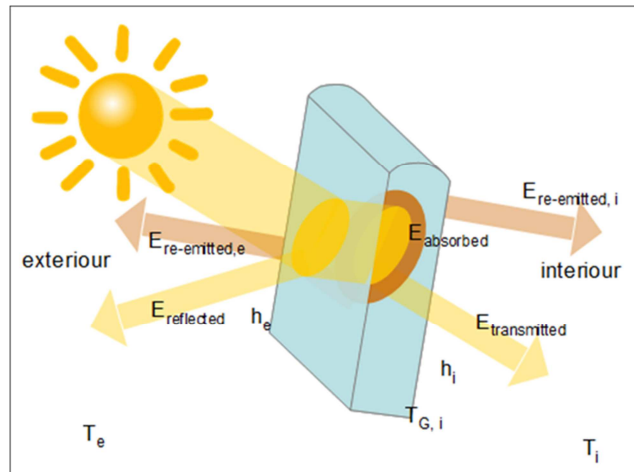

Figure 27: Schematic picture of the simulation of heat entrance through glazing into the vehicle cabin (tool from Saint-Gobain described in Hausberger, 2010)

The tool was originally used to establish simple look-up functions to consider benefit factors for better glazing quality and size in the AC type approval of passenger cars. This approach may also be followed for city buses to provide a “glazing correction factor” which describes the ratio of heat entrance with vehicle specific glass data to heat entrance for the “average” glass data used below. Such an approach would reward the use of better glass quality. This seems to be reasonable since this also reduces the cooling capacity demand in real bus operation.

Table 1: Measurement results in seven trips with the Volvo 7000 city bus in the city of Graz

	Sun intensity [W/m ²]	T-cabin [°C]	T-ambient [°C]	Heat entrance [W]	RH [%]	P_electr-AC measured [kW]
Measurement 1	724	21.0	22.0	3357	42%	2.2
Measurement 2	732	24.1	22.2	3142	41%	2.1
Measurement 3	652	24.9	22.8	2764	40%	2.4
Measurement 4	416	25.4	22.4	1620	42%	3.1
Measurement 5	617	22.3	19.5	2545	59%	2.8
Measurement 6	365	23.4	20.1	1363	58%	2.3
Measurement 7	386	23.4	19.0	1363	73%	2.1
Average	556	23.5	21.1	2307	51%	2.42

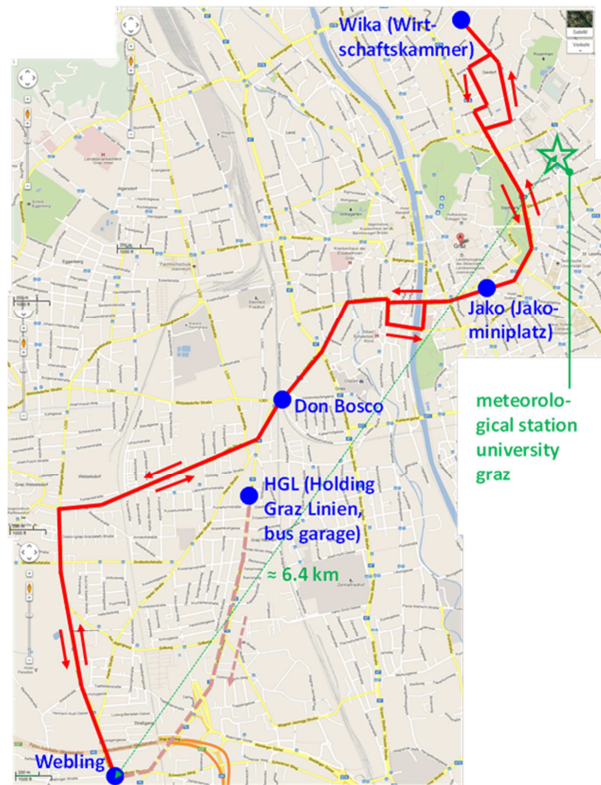

Figure 28: Plan of bus line 31 in Graz

3.2.3.2.2 Simplified simulation of the mobile air conditioning on a city bus

The simulation follows a heat balance based approach developed for passenger cars in [4], Figure 29.

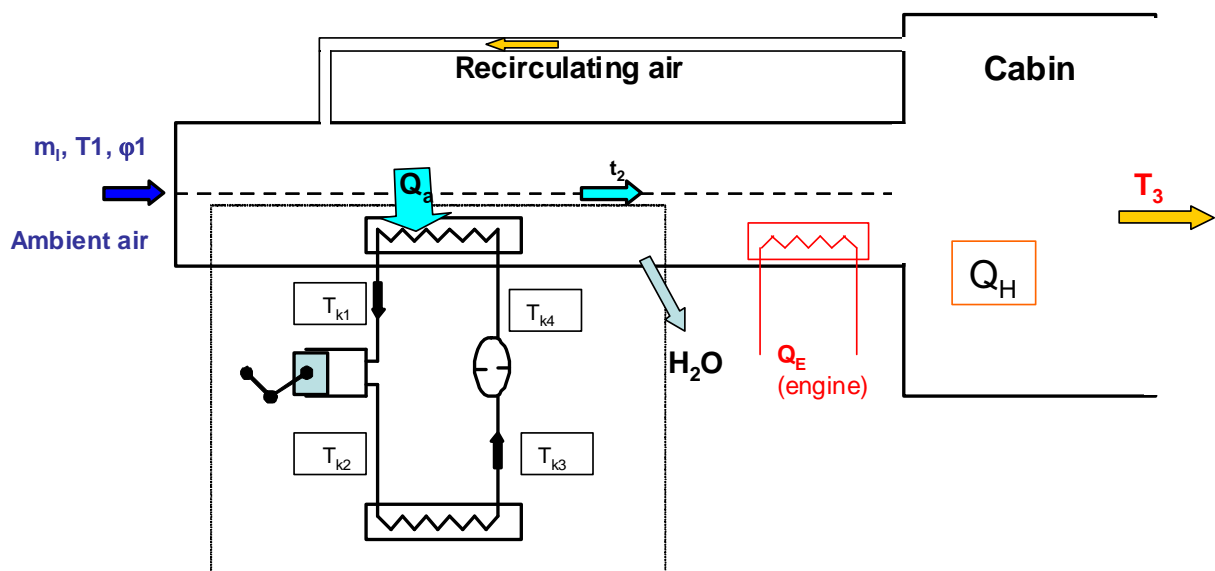

Figure 29: Schematic picture of the relevant parts of the MAC system

To calculate the Cooling Capacity CAP (Q_a) a heat balance can be made over the entire vehicle:

$$Q_a = \dot{m}_1 \cdot [h_{3(1+x)} - h_{1(1+x)} + (x_1 - x_2) \cdot C_w \cdot t_w] + Q_E + Q_H$$

The values for $h_{(1+x)}$ result from the temperature and the relative humidity of the humid air:

$$h_{i(1+x)} = c_{p_{dry\ air}} \times t_i + x_i \times (r_0 + c_{p_{steam}} \times t_i)$$

$$x_i = \frac{R_{dry\ air} \times p_{steam}}{R_{steam} \times p_{dry\ air}}$$

The partial pressure of steam and dry air is gained from the relative humidity and from the total pressure of the humid ambient air.

$$p_{steam_i} = \varphi_i \times p'_{steam_i} \quad \text{with } p'_{steam_i} \text{ as the saturation pressure.}$$

Table 2 summarizes the data used in the simulation.

Table 2: Data used for the moist air from the test cell to the vehicle cabin

Parameter	Value	Unit	Comment
R_{steam}	461.5	J/kgK	
$R_{dry-air}$	287	J/kgK	
$Cp_{dry-air}$	1	kJ/kgK	
Cp_{steam}	1.85	kJ/kgK	
C_{water}	4.19	kJ/kgK	
r_0	2500	kJ/kg	
Q_H	1.3	kW	Heat load from sun radiation, from opening and closing doors at the bus stop, from the driver, from the passengers and from heat transfer from the engine
% recirc. Air	0%	m_{rec}/m_{tot}	Zero % recirculated air are assumed here for the city bus operation ⁽¹⁾

(1). Average technology still needs to be verified by AC manufacturers.

The COP can be measured on an AC test stand or calculated from the air conditioning (AC) cycle. Figure 30 shows a simplified AC cycle. The CAP (Q_a) is entering the AC system during the evaporation of the coolant from 4 to 1. Then the coolant enters the compressor (1 to 2). After the compressor a higher temperature and pressure level is reached. With condensation from 2 to 3 the heat is released to the ambient. To close the cycle the coolant is then sucked through a throttle from 3 to 4.

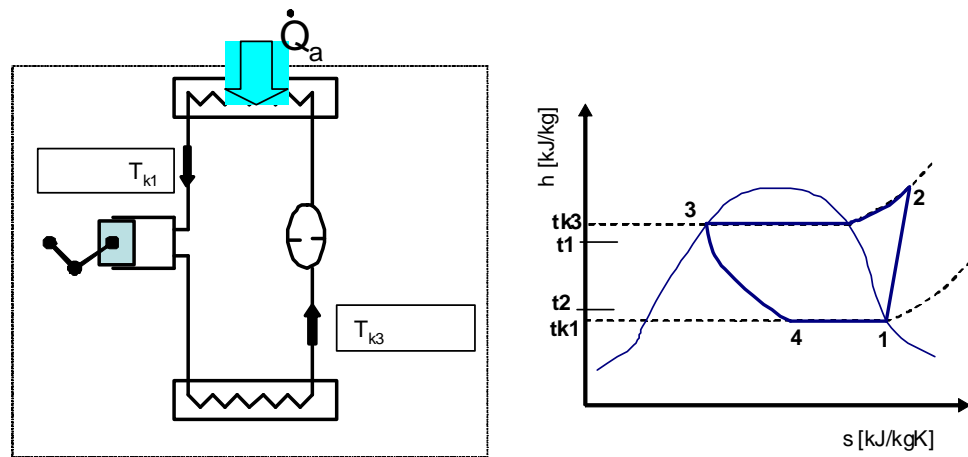

Figure 30: Schematic picture of the air conditioning cycle system

In the following the simulation of the simplified AC cycle is described.

If the temperature levels and the efficiencies of the compressor are known, the COP can be calculated for this simplified cycle:

$$\text{COP} = \frac{\dot{Q}_a}{P_{ce}} = \frac{h_4 - h_1}{(h_2 - h_1)/(\eta_m)}$$

The Enthalpy h_2 can be assessed by the isentropic standard cycle ($s = \text{constant}$ from over the compressor, i.e. point 1 to 2 in the AC cycle).

$$h_2 = \frac{h_{2s}}{\eta_{s-i}}$$

The power demand from the AC compressor can be estimated from the enthalpy difference, here for R134a as coolant, as:

$$P_{ce} = \dot{m}_{R134a} \times (h_2 - h_1)$$

The mass flow of the coolant can be calculated from the CAP demand:

$$\dot{m}_{R134a} = \frac{\dot{Q}_a}{(h_4 - h_1)}$$

The real AC cycles are more sophisticated, using e.g. under cooling at point 3 of Figure 30 and overheating at point 1. Again functions instead of look up tables are used for the properties of R 134a.

The values shown in Table 3 were used for the parameterisation of the simplified COP simulation.

Table 3: data used in the simulation of the AC cycle

Parameter	Value	Unit	Remarks
cp in superheated steam (1→2s)	1.1	[kJ/kgK]	Simplification to avoid look up table
η_{s-i}	0.6	-	Average efficiency compared to isentropic process
η_m	0.9	-	Average mechanical efficiency
$t_{k3} - t_1$	25	°C	Inclination of temperature in condenser against ambient
$t_2 - t_{k1}$	14	°C	Inclination of temperature in evaporator against t2

The simulation and its input parameters were validated by recalculation of the average measured bus route in the city of Graz. The total power demand measured from fan and compressor is around 2.2 kW which is good in line with the 2.0 kW simulated. However, the uncertainties especially for effects from opening and closing doors and from sun radiation are rather large.

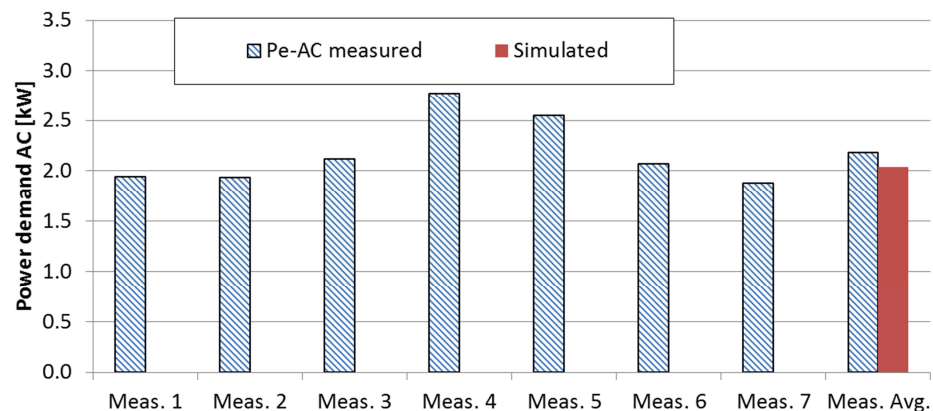

Figure 31: Comparison of measured and simulated total power demand of the AC system of the Volvo 7000 Hybrid bus on the bus route in the city of Graz

Since the ambient conditions were not “average” conditions during the measurements, the simulation tool can be used now to calculate typical power demand cycles for AC systems of a bus as P_{AC} power demand curve.

3.2.3.2.3 Power demand cycle suggested for AC of a city bus

From existing European weather data used in (Hausberger, 2010) ambient conditions of 24°C and 50% relative humidity and a sun intensity of 550 W/m² were used for the simulation of “average conditions”. Adaptations of these values are simply possible if available from other regions of the world. The heat transmitted from sun radiation into the bus cabin was simulated using the tool developed by Saint-Gobain (Hausberger, 2010) as shown already before. For the bus the 550 W/m² sun intensity lead to 2.7 kW heat entrance into the cabin with the glazing assumed to be representative for buses (Table 4).

Table 4: Glazing data used to simulate the heat entrance into the bus cabin due to sun radiation

Glass position	Glass type (VSG)	installed	installation angle	transparent area
		glasses amount		
			[°]	[m ²]
windscreen	2.1mm lite green - 0.76mm PVB - 2.1mm clear	1	75	2.64
front door quater	none	0		
front door side lite	2.1mm clear-PVB-PET-PVB-2.1mm clear	0	80	0
rear door side lite	2.1mm lite green - 0.76mm PVB - 2.1mm clear	10	80	1.1
rear door quater	3.15 dark grey	0	80	0
sixth lite 1	none	0		
sixth lite 2	none	0		
backlite	2.1mm clear-PVB-PET-PVB-2.1mm clear	1	80	2
sliding roof	none	0		

Beside the “suggested” average data also variations of ambient conditions have been simulated to show the sensitivity of the AC power demand. Results are shown in Table 5 and in Figure 32.

Table 5: Ambient conditions and HVAC settings as input into the simulation tool and resulting CAP and power demand for the AC system of a city bus in different conditions

Condition simulated	Ambient conditions			HVAC settings		Results				
	t1 [°C]	φ1 [%]	Qh [kW]	m-flow [kg/h]	t3 [°C]	Pel [kW]	Qa [kW]	m_R134a [kg/s]	Pce [kW]	fuel cons. [kg/h]
low	15	75%	2.3	1000	22	0.30	-0.3	0.00	0.14	0.16
medium	24	65%	6.0	3000	22	0.91	-14.0	0.11	9.03	2.39
high	30	45%	11.2	3600	22	1.10	-26.1	0.22	20.89	5.08
Extreme	40	90%	11.2	14000	28	4.26	-332.9	3.24	363.90	81.93
Volvo Bus in Graz	21	51%	3.9	3300	24	1.00	-1.8	0.01	1.03	0.23
Suggested	24	50%	5.0	3300	22	1.00	-7.6	0.06	4.89	1.52

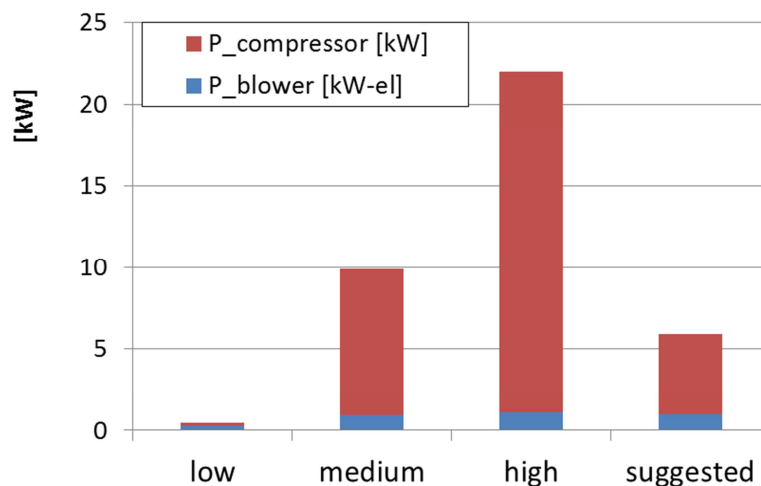

Figure 32: Power demand for the AC system of a city bus simulated for different conditions

For a 2 axle city bus in typical operation this simulation gives 1 kW electric energy for the blowers and 4.9 kW for the compressor of the AC system. The compressors can be driven by electric motors or mechanically connected to the power pack. Possible interfaces to the HILS simulation tool have been discussed already before.

For different size classes of buses and for coaches different AC power demand values can be defined.

Furthermore the generic AC system could be replaced for CO₂ emission simulation in future on demand of the OEM by OEM specific data if the OEM uses improved AC technologies. Similarly the glazing data could easily be exchanged in the simulation to provide a different heat entrance and thus reduce the demanded cooling capacity.

Figure 33 shows the AC power demand cycle in the WHVC. For the simulation of vehicle specific CO₂ emissions the WHVC may later be replaced by a specific city bus cycle or may be weighted by the “WHVC weighting factors (see chapter 3.3). Due to the simple constant AC power demand it can easily be transferred to any other cycle.

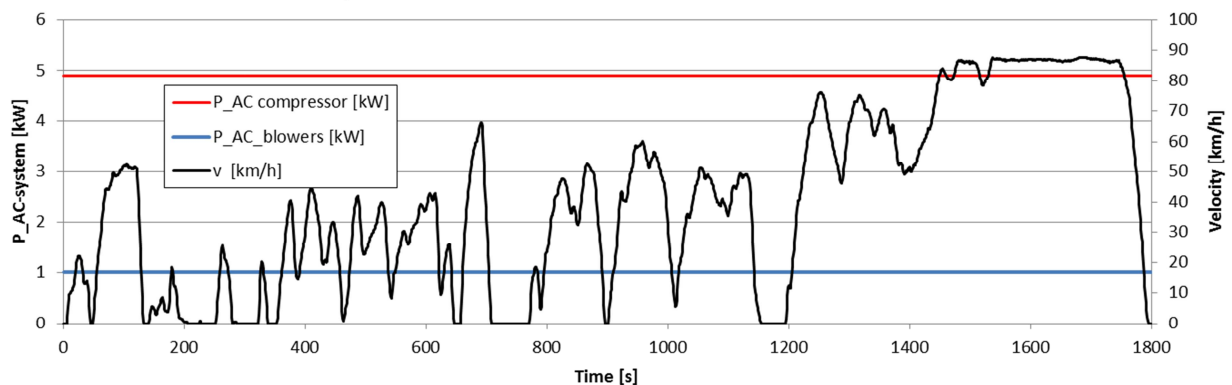

Figure 33: Schematic picture for the option of a “P_{AC}” cycle for a 2 axle city bus operation added to the WHVC

In Working Paper No HDH-09-06 [5] a simple bonus factor was discussed. This bonus factor does not consider AC technology and glazing quality but just sets the efficiency of the actuation of the AC system in a HDH in ratio to the efficiency of a conventional HDV. Since the efficiency of the AC actuation in a hybrid system can hardly be accurately assessed without HILS simulation or measurement, this approach was not further developed.

3.2.3.2.4 Recommendations for PTO and auxiliaries

It is recommended

- Not to consider PTO and auxiliaries in the HILS application when the engine test bed cycle for regulated pollutants is computed to be comparable to conventional engines. Similar to conventional engines several auxiliaries will be engaged in engine testing on the engine test bed. Adding PTO and auxiliaries just to HDH testing would just increase the engine load for HDH power packs compared to conventional engines.
- Consider to include relevant PTO and auxiliaries in the test procedure for vehicle related energy consumption and CO₂-emissions in [g/km]. Relevant are components which have potential for further improvement and which have a reasonable share in HDV CO₂ emissions. Since vehicle related CO₂ emissions have to be directly comparable for HDH and for conventional HDV, a harmonisation of the approaches for both vehicle categories is important (see also chapter 3.3.2).

3.3 **Task 5: Development of WHVC weighting/scaling factors to represent real world vehicle operation**

The WHVC was developed in such a way that it includes relevant real life vehicle operation with appropriate weightings. That means the cycle is representative for an average HDV but not for single vehicle classes. The separation of the WHVC cycle into three different road categories allows the application of weighting factors for the three different cycle parts in order to make the adapted WHVC fit real life operating conditions of a certain vehicle class properly [6].

The WHVC weighting factors shall give the WHVC parts “urban”, “road”, “motorway” different weights for different vehicle classes to adapt the resulting engine load better to real life operation of the vehicle.

As prerequisite for this task typical real world driving conditions have to be allocated to vehicle categories. The definition of vehicle categories needs to be explicit and has to be applicable to all HDV. Such allocations for test cycles to HDV classes exist in Japan and US. Here the European draft HDV-CO₂ test procedure is taken as basis since it has a very detailed classification into seven test cycle categories (see [4] for more details). The axle configuration and the maximum gross vehicle weight define the matrix of HDV classes and corresponding representative real world driving cycles (see Figure 34:).

Identification of vehicle class		Segmentation (vehicle configuration and cycle allocation)					Norm body allocation						
		Long haul	Regional delivery	Urban delivery	Municipal utility	Construction	Standard body	Standard trailer	Standard semitrailer				
Heavy Goods Vehicles	Identification of vehicle class		Segmentation					Norm body allocation					
	Axles	Axle configuration	Chassis configuration	Maximum GVW [t]	<-- Vehicle class	Long haul	Regional delivery	Urban delivery	Municipal utility	Construction	Standard body	Standard trailer	Standard semitrailer
	2	4x2	Rigid	>3.5 - 7.5	0		R	R			B0		
	2	4x2	Rigid or Tractor	7.5 - 10	1		R	R			B1		
			Rigid or Tractor	>10 - 12	2	R	R	R			B2		
			Rigid or Tractor	>12 - 16	3		R	R			B3		
			Rigid	>16	4	R+T	R		R		B4	T1	
			Tractor	>16	5	T+S	T+S						S1
		4x4	Rigid	7.5 - 16	6				R	R	B1		
			Rigid	>16	7					R	B5		
		Tractor	>16	8					T+S			W1?	
	3	6x2/2-4	Rigid	all weights	9	R+T	R		R		B6	T2	
			Tractor	all weights	10	T+S	T+S						S2
		6x4	Rigid	all weights	11					R	B7		
			Tractor	all weights	12					R			S3
		6x6	Rigid	all weights	13					R	W7		
			Tractor	all weights	14					R	W7		
4		8x2	Rigid	all weights	15		R				B8		
	8x4	Rigid	all weights	16					R	B9			
	8x6 & 8x8	Rigid	all weights	17					R	W9			

Identification of vehicle class		Segmentation and cycle allocation								
Axles	Axle configuration	Chassis configuration	Characteristics	Maximum GVW [t]	<-- Vehicle class	Heavy Urban	Urban	Suburban	Interurban	Coach
2	4x2	City	Class I + low floor or low entry, no luggage compartment	<18	B 1	HU	UR	SU		
		Interurban	Class II + luggage compartment and/or floor height ≤0.9m	<18	B2				IU	
		Coach	Class III + floor height ≥0.9m and/or double decker	<18	B3					CO
3	6x2	City	Class I + Low floor or low entry, no luggage compartment	>18	B4	HU	UR	SU		
		Interurban	luggage compartment and/or floor height ≤0.9m	>18	B5				IU	
		Coach	floor height ≥0.9m and/or double decker	>18	B6					CO

Figure 34: Matrix of 17 HGV classes with 5 corresponding test cycles and 6 bus and coach classes with 2 corresponding cycle-sets

With this classification matrix there are two basic options for the elaboration of weighting factors. Either the calculation is done for the total of 23 vehicle classes in order to consider class specific influences or seven sets of weighting factors are calculated which consider only cycle specific influences. Weighting factors for different vehicle categories which are allocated to the same CO₂ test cycle would be very similar since only the vehicle specific data has some influence on the resulting engine load cycle. Since the average vehicle specific data within each vehicle class is unknown, no additional accuracy would be gained by the more detailed approach. Therefore it is suggested to follow the much simpler solution with seven cycle specific WHVC weighting factors.

When the application of weighting factors will be implemented, the weighting can be used for conventional heavy duty engines as well as for hybrid powerpacks. A main field of application of the weighting factors could be the vehicle specific CO₂ emission testing for HDH and for conventional HDV since the WHVC could serve as

a common and short test cycle beside the CO₂ test cycles. If specific correction factors are to be obtained by measurements or by simulation in the WHVC, they could be converted to CO₂ test-cycle specific results by application of the WHVC weighting factors. Whether this option will be introduced is open.

3.3.1 *Elaboration of weighting factors for different parts of the WHVC*

The software PHEM was used to calculate power demand, engine speed, energy consumption, emissions, vehicle speed and derivatives for the three different sub-cycles (urban, road, motorway) of the WHVC and for the CO₂-test cycle representative for a HDV class. Then the WHVC-weighting factors for each of these WHVC-sub-cycles are calculated iteratively to reach the lowest deviation in the results between the weighted WHVC and the representative driving cycle. The resulting WHVC-weighting factors are then valid for the considered vehicle category.

When calculating the weighting factors the values are varied between 0 and 1 while the sum of the three weighting factors has to be exactly 1. Figure 35 lists the weighting factors for the different kinematic parameters of a test cycle, which are used in Equation 5. Depending on the final application of the WHVC weighting factors the values shown in Figure 35 may be tested with a sensitivity analysis to check if the WHVC weighting factors are robust for the application planned.

Speed	a_pos	a_neg	Ppos	Pneg	FC	NOx	dP_2s ABS	Ampl3s	Total
0.15	0.12	0.12	0.15	0.15	0.15	0.06	0.05	0.05	1.00

Figure 35: Weighting factors for kinematic parameters (WF_{Ki})

$$\sum_{n=Urban,Road}^{Motorway} \left(WF_{WHVC-n} \times \sum_{i=Kin.Param 1}^{Kin.Param j} WF_{Ki} \times \sqrt{\left(\frac{KPi_{RS} - KPi_{WHVC-n}}{KPi_{RS}} \right)^2} \right) = KP_{Tot} = Minimum$$

- With: WF_{WHVC-n}..... WHVC weighting factor
- WF_{Ki}..... Weighting factor of the kinematic parameter i
- KPi_{RS}..... Value of the kinematic parameter I in the representative cycle
- KPi_{WHVC-n}..... Value of the kinematic parameter I in the WHVC sub-cycle
- KP_{Tot} Total weighted deviation of the kinematic parameters between weighted WHVC and representative real world cycle

Equation 5: Main equation for calculation of WHVC weighting factors

With this main equation the lowest deviation KP_{Tot} in the kinematic parameters (KP_i) is calculated by variation of the weighting factors for the three sub parts of the WHVC (WF_{WHVC-n}). In addition the maximum deviation for every single kinematic parameter has to be in a specified tolerance range.

The method for the calculation of WHVC weighting factors was applied for city buses yet (see Figure 36). Unsurprisingly, for the considered city bus cycle the

calculated weighting factors are 100% for the WHVC urban sub-cycle, the two remaining sub-cycles are weighted with 0%.

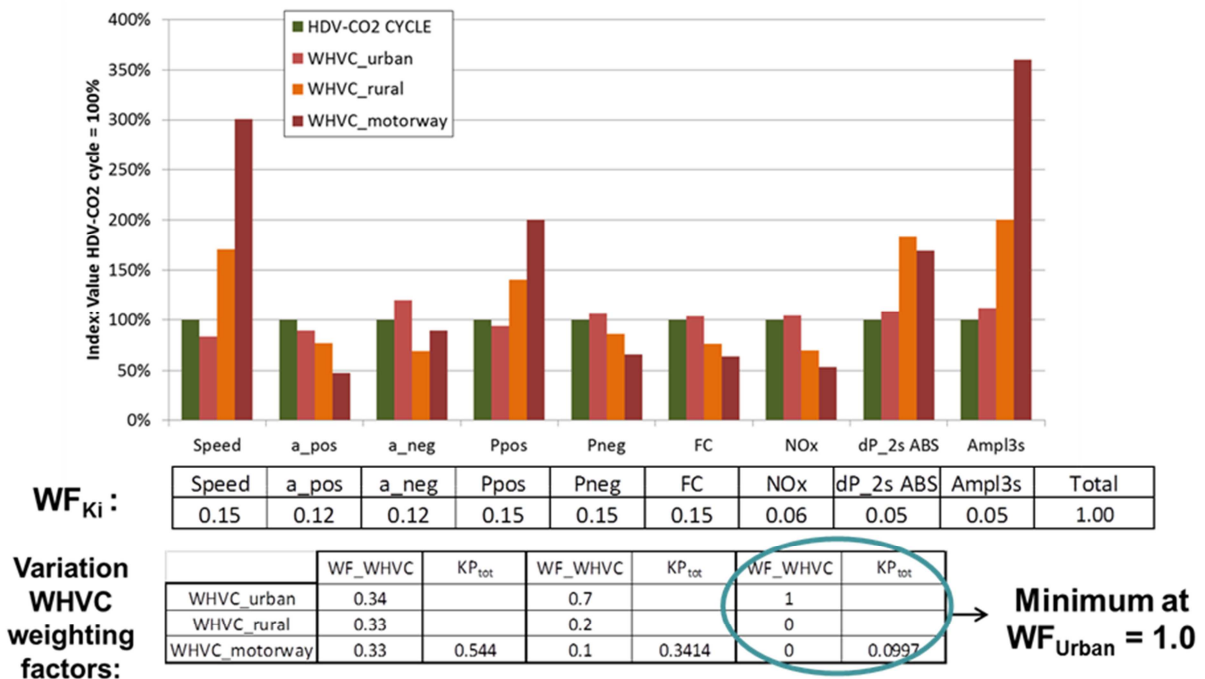

Figure 36: Calculation of WHVC weighting factors for city bus cycle

Since the representative driving cycles for the European HDV-CO₂ test procedure are still under development, this task was only carried out for the already existing city bus cycle. As soon as the remaining cycles are available (expected until end of 2012), this task will be finalised for all cycles and in a final validation phase the weighting factors for the different kinematic parameters will be analysed in order to determine the final values for the WHVC weighting factors.

The calculated weighting factors will then be valid for the European cycles listed in Figure 34. However, the method can be universally used by legislative institutions in other areas to get weighting factors for the WHVC which consider the influence of either specific vehicle classes or specific cycles in other countries. To apply the method for example to the Japanese standard vehicle specification for fuel efficiency as defined in Kokujikan No. 281 the kinematic parameters would have to be calculated for the Japanese test cycles and for the corresponding truck categories (Figure 37). Then the WHVC-weighting factors have to be gained by looking for the minimum deviation of KP_{Tot} between the weighted WHVC and the representative test cycle.

truck category			empty vehicle mass (kg)	maximum payload (kg)	number of persons	test vehicle mass (kg)	tire dynamic radius (m)	overall height (m)	overall width (m)	transmission gear ratio							diff gear ratio	rate of inter-city mode
category	vehicle mass range	pay load range								1st	2nd	3rd	4th	5th	6th	7th		
T1	3.5t < & ≤ 7.5t	≤ 1.5t	1957	1490	3	2757.0	real vehicle data of the most close to average v1000	1.982	1.695	real vehicle data	real vehicle data of the most close to average v1000	10%						
T2		1.5t < & ≤ 2t	2356	2000	3	3411.0		2.099	1.751									
T3		2t < & ≤ 3t	2652	2995	3	4204.5		2.041	1.729									
T4		3t <	2979	3749	3	4908.5		2.363	2.161									
T5	7.5t < & ≤ 8t	—	3543	4275	2	5735.5		2.454	2.235									
T6	8t < & ≤ 10t	—	3659	5789	2	6608.5		2.625	2.239									
T7	10t < & ≤ 12t	—	4048	7483	2	7844.5		2.541	2.350									
T8	12t < & ≤ 14t	—	4516	7992	2	8567.0		2.572	2.379									
T9	14t < & ≤ 16t	—	5533	8900	2	10038.0		2.745	2.480									
T10	16t < & ≤ 20t	—	8688	11089	2	14287.5		3.049	2.490									
T11	20t <	—	8765	15530	2	16585.0		2.934	2.490					30%				

Figure 37: Japanese standard vehicle specification for fuel efficiency – truck category exemplarily (Kokujikan No. 281)

3.3.2 Task 5.3: Elaboration of options to use the HILS method in the HDV CO₂ test procedure

We define here as HDV CO₂ test procedure a method, which results in the vehicle specific CO₂-emissions and/or fuel consumption in [g/km] or in derivate of this unit, e.g. [g/ton-km]. In contrary to the engine work based emissions [g/kWh] the vehicle specific CO₂ emissions certainly are much more sensible to the absolute level of work to be delivered by the propulsion system of a vehicle. In contrary to the regulated pollutant emissions (CO, HC, NO_x, PM) for fuel consumption and for CO₂ small differences already define whether a vehicle will be seen as very fuel efficient or not.

For these reasons a test procedure for HDV CO₂ emissions shall:

- Be very accurate in determining the difference between makes and models
- Provide the result for a typical mission profile of a vehicle category. Vehicle speed, gradient, vehicle loading, driver behaviour shall be representative to stimulate technological improvements which have similar benefits on the fuel efficiency in typical real world operation and in the test cycle. E.g. aerodynamic drag has low influence in a city bus cycle but high influence in a typical long haulage driving profile.
- Include those auxiliaries and PTO devices for which reasonable options to reduce their energy consumption exist and which also have a reasonable share in total CO₂ emissions from HDV.

Japan, USA and China do have already introduced CO₂ test procedures for HDV which partly fulfil these requirements. In the EU such a procedure is under development. The sources for the regulations for conventional HDV are listed below.

USA: In September 15, 2011 the final rule of “Greenhouse Gas Emissions Standards for Medium- and Heavy-Duty Engines and Vehicles” was published in the U.S. Code of Federal Regulations. Most parts for this approach can be found in Part 1037 of the 40 U.S. Code of Federal Regulations.

The US approach uses component testing combined with a simulation tool (GEM model).

Japan: The Japanese provisions and limits are described in the Japanese *Energy Conservation Standards*. The corresponding test procedure, called the TRIAS, was already published in 2007. The standards are given as km / liter and become applicable from April 1st, 2015.

The Japanese approach also uses component testing combined with a simulation tool.

China: No translation of the regulations were found yet. A first overview is given in www.theicct.org/2011/04/overview-vehicle-emissions-controls-china.

The Chinese approach is based on chassis dyno testing for a “parent vehicle” of a basic vehicle type. For variants of a parent vehicle the change in fuel consumption can be obtained by simulation or by measurements.

EU27: The introduction of the test method is foreseen in 2014 for some HDV categories. A first description of the test method can be found in [4].

The EU approach also uses component testing combined with a simulation tool (ECM model).

Since vehicle related CO₂ emissions shall be directly comparable for HDH and for conventional HDV, a harmonisation of the approaches for CO₂ testing for both vehicle categories is important. Since the existing approaches for conventional HDV around the world are not harmonised and certainly will give different results when applied for the same vehicle, the HILS method can hardly be made comparable to all existing methods.

For the elaboration of the option to make the HILS approach applicable for the determination of vehicle specific CO₂ emissions, we assumed the following scenario:

- 1) HILS will be applied as GTR first for type approval for regulated pollutant emissions from HDH engines in [g/kWh] units. The related test protocol and simulation tool will be finalised in 2014. HILS application for vehicle related CO₂ emissions will be implemented later
- 2) Existing regulations in US and Japan for treating HDH in vehicle specific CO₂ emissions will remain valid at least until 2015.
- 3) In the EU the HDH will not be included into the vehicle specific CO₂ emission test procedure before 2015
- 4) Until 2015 updates for the vehicle specific CO₂ emission test procedure for conventional HD vehicles could be made in US, Japan, EU and China if necessary. Thus all simulation tools could then provide the course of power demand and rotational speed simulated at the axle of the combustion engine from vehicle specific input data.
- 5) In these updates of the approaches for conventional HDV also auxiliaries and PTO can be included if found to be relevant. If not, these components shall also not be considered to be relevant for HDH.
- 6) If the influence of advanced HDV technology on fuel consumption shall be made visible by a simulation tool, high effort in programming is also

necessary for conventional vehicles (e.g. control of automatic gear boxes, intelligent control of energy flows in auxiliaries, floating engine maps¹², etc.). To include all functionalities into different simulation tools for HDH and for conventional HDV will cause difficulties in harmonisation and in the maintenance of the models. To overcome this problem either one model shall be used for all applications (HILS for all) or a nesting of the models is necessary.

- 7) Although “HILS for all” may be necessary in future from a scientific point of view, we do not expect this to be an option already in 2015 or 2016 since the effort to set up a HILS model with all relevant control units is high and therefore a costly approach if it has to be done for each HDV model. Such an approach needs sufficient time for necessary standardisations and testing to evaluate if this is a practicable solution.
- 8) Therefore the option of nesting the HILS model into a common and simpler HDV CO₂ model is elaborated here.

Several options have been drafted and have been discussed in the meetings of the HDH working group. The resulting option is shown in Figure 38.

Conventional: The test procedure for conventional engines is based on engine test bed measurements in one or more test cycles (e.g. UN/ECE Regulation No. 49; as amended in GRPE/2012/4). The engine load cycle typically depends on the full load curve of the engine to make sure the entire engine map is tested.

HILS: The HILS approach for regulated pollutants of a HDH power pack as described before would straight forward deliver an engine test cycle for the combustion engine on the engine test bed. Therefore the test procedure as defined for conventional engines can be applied by just replacing the test cycle. This approach is already implemented successfully in Japan. The actual suggested adaptation just makes sure that the power pack will run in similar relative load points to those required for the conventional engine. In the actual approach for all engines the WHTC is supposed. However, the approach works also for all other engine cycles. Instead of the “powerpack test cycle” as shown here also a vehicle speed cycle can be used as input.

HDV-CO₂: Vehicle specific component test results are used as model input in the simulation tools for the vehicle specific CO₂ emissions. Typically high effort is necessary to provide accurately measured values for driving resistances, transmission losses and efficiency maps or energy consumption maps of engines and auxiliaries. For calculating the CO₂-emissions a vehicle speed cycle is applied which is representative for the vehicle class of the type approved HDV model. The HDV simulator will then calculate the necessary engine torque and speed. The resulting engine load cycle is used in the HDV simulator for conventional HDV to interpolate CO₂ emissions or fuel consumption from an engine map. For HDH this cycle can be used as interface to the HILS model. This cycle from the HDV simulator (“HDV-CO₂ power pack cycle”) is in the format of the power pack axle

¹² “Floating engine map” means that several characteristics of the engine relevant for combustion and after treatment can be controlled by functions of ambient conditions and of sensor signals from components. E.g. injection timing and EGR rate of the engine can be varied at identical load points depending of the temperature of the SCR catalyst to fulfil the NO_x exhaust gas limits with maintaining best fuel efficiency under all driving conditions.

cycle (WHDHC B-2) as outlined before for the HILS simulator. If necessary the power cycles for the auxiliaries and for the PTO can be exchanged together with the power pack axle cycle by just adding more columns in the file.

HDH-CO₂: The HILS simulator is run with the “HDV-CO₂ power pack cycle” instead of the WHDHC. In the case of vehicle related CO₂ emissions the resulting load cycle for the ICE is then not measured on the test stand but simply used to interpolate the CO₂ emissions and the fuel consumption from the engine map. This can be done in the HILS simulator or in the HDV simulator as long as the same test procedures are used to obtain the map and the same interpolation routine is used. It seems to be more straight forward to do this calculation in the HDV-CO₂ simulator since there the conversion into [g/km], [g/ton-km] etc. can be done more easily since cycle length and vehicle loading are available in this tool.

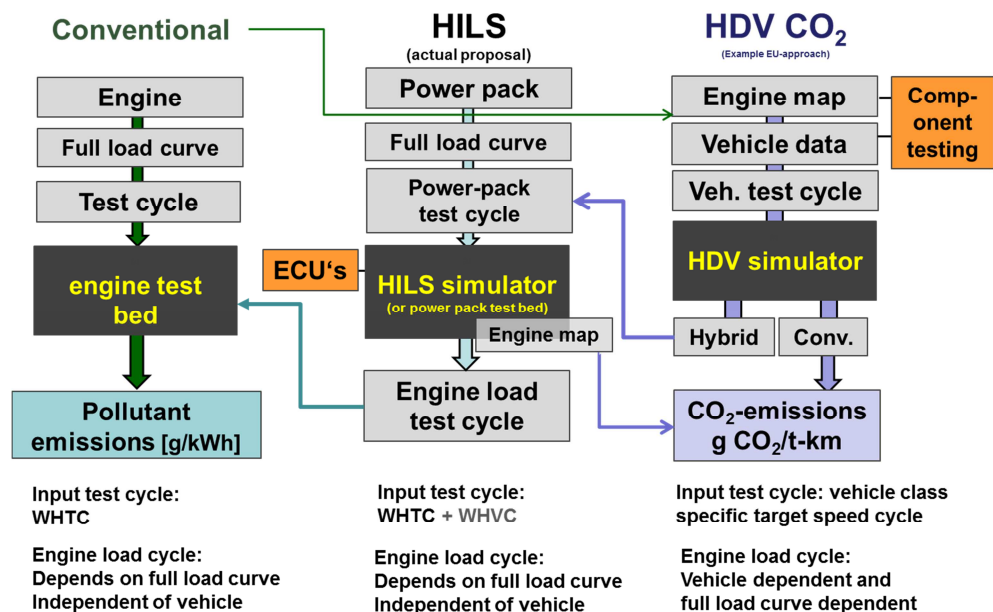

Figure 38: Data flow for a nesting of the test procedures for pollutant emissions from combustion engines of conventional HDV and of HDH with the test procedure for vehicle related CO₂ emissions

With this approach the nesting can be done by exchange of two standardised file formats. It is suggested to implement the WHDHC B-2 method in the HILS simulator to test the option described above in the next project phase. To run the WHDHC B-2 in the HILS model, the driver model of the existing HILS tool needs to be adapted. It is suggested just to add this second driver model and to implement a switch to select the proper driver model.

The approach shown cannot be applied to HDH with more than one power pack axle, such as a HDV with wheel hub motors. However, for these vehicles the option with the WHDHC B-1 (wheel hub cycle) could be applied if a simple split of the total torque to the single driven axles can be made. If this split needs to be controlled by the ECU, the method described does not work. In this case the entire vehicle has to be simulated with a vehicle speed cycle in HILS. It is not clear yet, if such HDH designs will be ready for type approval already in near future. If yes, effort will be necessary to make the power demand resulting from HILS comparable with the

results which the HDV CO₂ simulator would provide¹³. Otherwise the results in [g/km] could not be compared to those of other HDV.

¹³ For example the resulting total work at the wheel hubs can be compared from the HILS simulator and from the HDVCO2 simulator for the same vehicle input data. Then the emissions computed by the HILS model could be corrected by the ratio of wheel hub work over the test cycle provided from HDV-CO2 and from HILS. Certainly the same engine fuel consumption maps need to be applied in HILS and HDV-CO2.

4 References

- [1] H. Dekker, M. Planer, S. Hausberger and J. Fredriksson, "Summary report of the Research Program on an Emissions and CO2 Test Procedure for Heavy Duty Hybrids (HDH)," in *HDH-10-03*, Geneva, 2012.
- [2] S. Hausberger, M. Rexeis, M. Zallinger and R. Luz, "Emission Factors from the Model PHEM for the HBEFA Version 3," in *Report Nr. I-20/2009 Haus-Em 33/08/679*, 2009.
- [3] USEPA, "Heavy-Duty GHG Overview and Hybrid System Testing," in *HDH-07-09*, Vienna, 2011.
- [4] S. Hausberger, M. Rexeis, A. Kies, L.-E. Schulte, H. Steven, R. Verbeek and et.al., "Reduction and Testing of Greenhouse Gas Emissions from Heavy Duty Vehicles - LOT 2; Development and testing of a certification procedure for CO2 emissions and fuel consumption of HDV," in *Final Report Contract N° 070307/2009/548300/SER/C3*, 2012.
- [5] S. Hausberger and G. Silberholz, "Developing a Methodology for Certifying Heavy Duty Hybrids based on HILS," in *HDH-09-06*, Tokyo, 2012.
- [6] H. Stevens, "Development of a World-wide Harmonised Heavy-duty Engine Emissions Test Cycle," in *TRANS/WP29/GRPE/2001/2*, Geneva, 2001.
- [7] Kokujikan No. 281, "Test procedure for fuel consumption rate and exhaust emissions of heavy-duty hybrid electric vehicles using hardware-in-the-loop simulator system," March 16, 2007.
- [8] Kokujikan No. 282, "Test procedure for HILS system provisional verification for heavy-duty hybrid electric vehicles," March 16, 2007.
- [9] USEPA, "HD Hybrid Powertrain Testing," in *HDH-05-10*, Ann Arbor, 2011.
- [10] H. Bach, A. Weber, S. Hausberger and et.al., "Optimierungspotenziale in der Entsorgungslogistik (Potential for optimisations of logistics in the disposal of waste)," in *Schriftenreihe Umweltschutz und Ressourcenökonomie Band 40*, 2003.

5 References

Delft, 27 september 2012



Martijn van Ras
Projectleader

Placeholder



Henk Dekker
Author