

JULY 2017

A Direct Vision Standard for Heavy Goods Vehicles

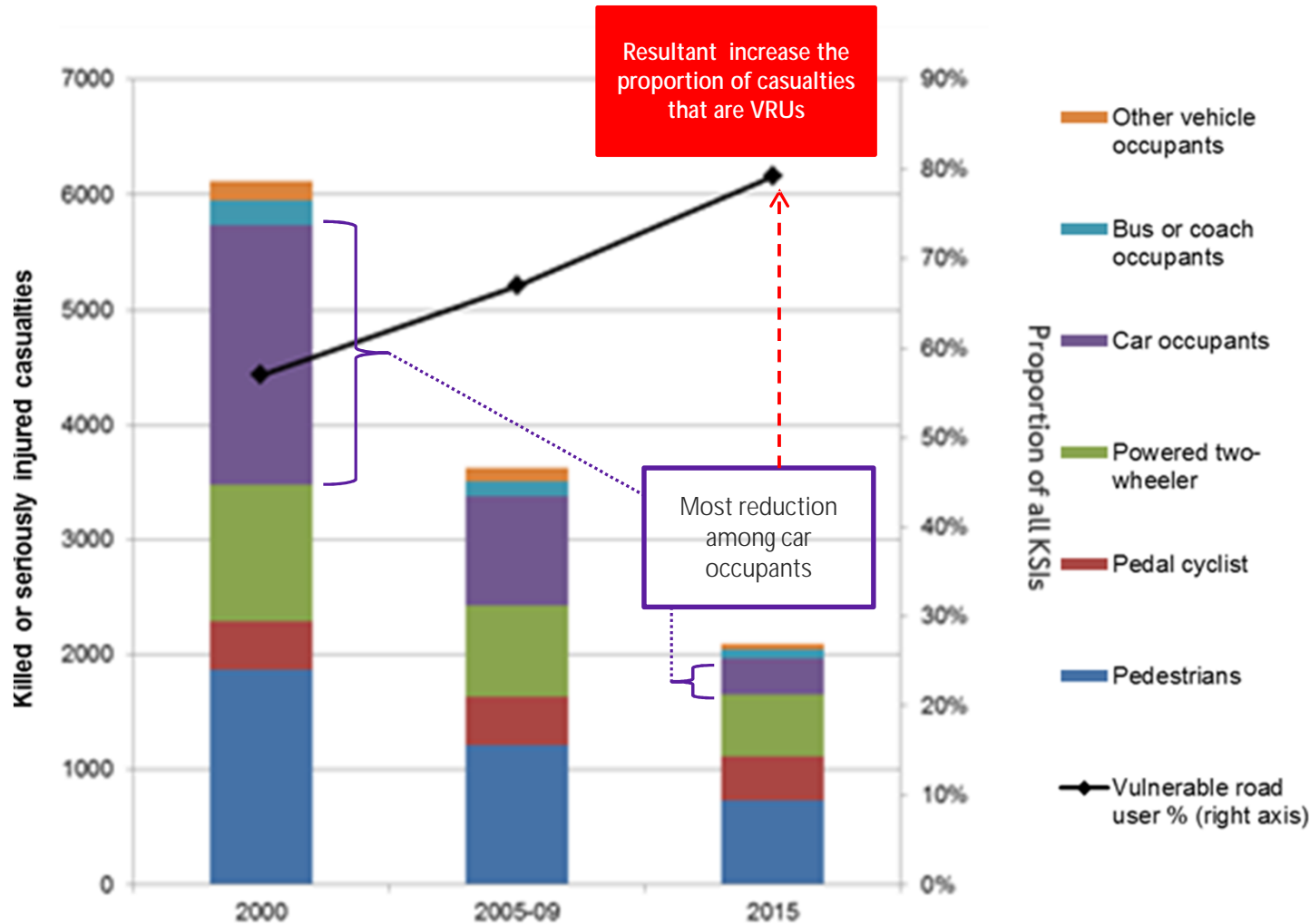

The road safety context for DVS – Vision Zero



Vulnerable road users are disproportionately involved in collisions (80% of all KSIs)

Changing travel patterns and increased pressure from a growing and ageing population



3 The road safety context for DVS – Vision Zero

To reduce road danger so that no deaths or serious injuries occur on London's roads

Vision Zero for London

A fundamental conviction that **loss of life and serious injuries are not acceptable nor inevitable**

Ensuring **road danger reduction is a common priority central to all transport schemes**

Requires **reducing the dominance of motor vehicles** and the targeting of **road danger at source**

People make mistakes so the system needs to accommodate the human factor and ensure impact energy levels are not sufficient to cause fatal or serious injury.



Safe Speed



Safe Roads



Safe Vehicles



Safe Behaviours



The road safety context for DVS – Road risk and HGVs

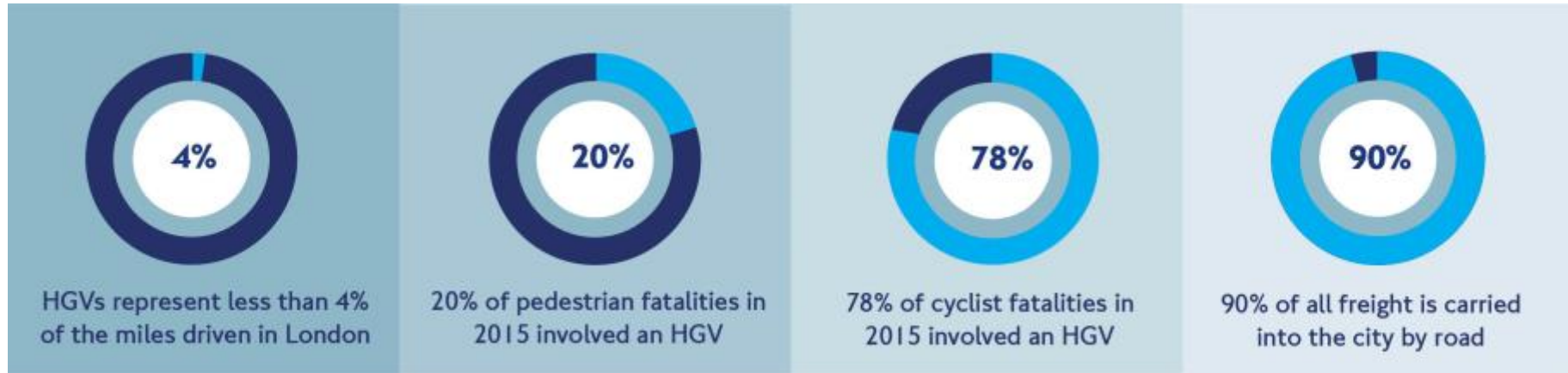

- HGVs are over represented in fatalities, especially with vulnerable road users.
- Evidence shows a clear correlation between HGV cab design and driver blind-spots, reaction times and the safety of vulnerable road users



A comprehensive safety programme

Safer operations

- Encouraging, supporting and recognising safe and compliant fleets

Safer people

- Improving driver and manager knowledge, skills and performance

Safer vehicles

- Stimulating innovative HGV design and providing evidence for change

Safer supply chains

- Using buying power and planning to manage road risk in supply chains



6

The Blindspot



Safer Trucks programme

Workstream 1

Improving the safety of existing vehicles through an approved testing methodology for retro-fit or dealer-fit HGV safety technology



Workstream 2

Evidence for next generation urban truck. Market research and technical research on operational off-road site conditions and benefits of direct vision



Workstream 3

Field of view standard and business case to support regulatory change through review of General Safety Regulation

Workstream 4

Encouraging uptake of 'safer trucks' through effective communications and programme evaluation



Safer Trucks: Providing the evidence for change

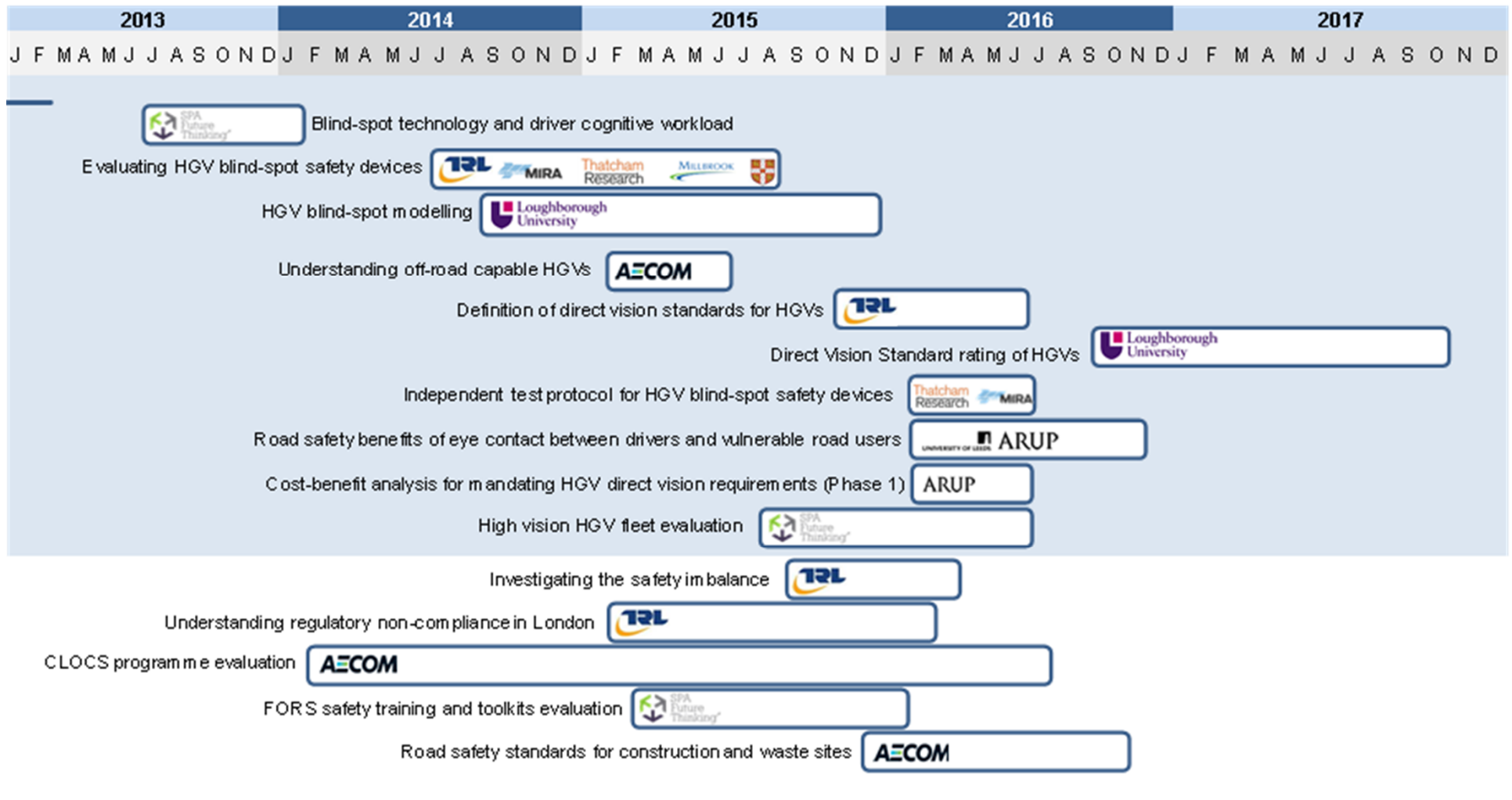

<https://tfl.gov.uk/info-for/deliveries-in-london/delivering-safely/safer-trucks>



Optimum Vision - Retrofit blind-spot technology



There is a 'tipping point' which is quickly being approached; there are only so many pieces of equipment drivers can manage before it becomes overwhelming

**Future Thinking, Driver
Distraction**

- HGV blind-spot technology has a part to play where direct vision is not possible
- HGV suitability for the urban environment is optimised through a combination of indirect and direct vision
- TfL is developing an objective, repeatable and robust testing protocol for use by aftermarket product suppliers (and vehicle manufacturers)
- Research has shown that whilst drivers and managers deem technology useful, cognitive overload can become an issue

Variation in direct vision - front

Up to 1.4 metre difference in blind-spot

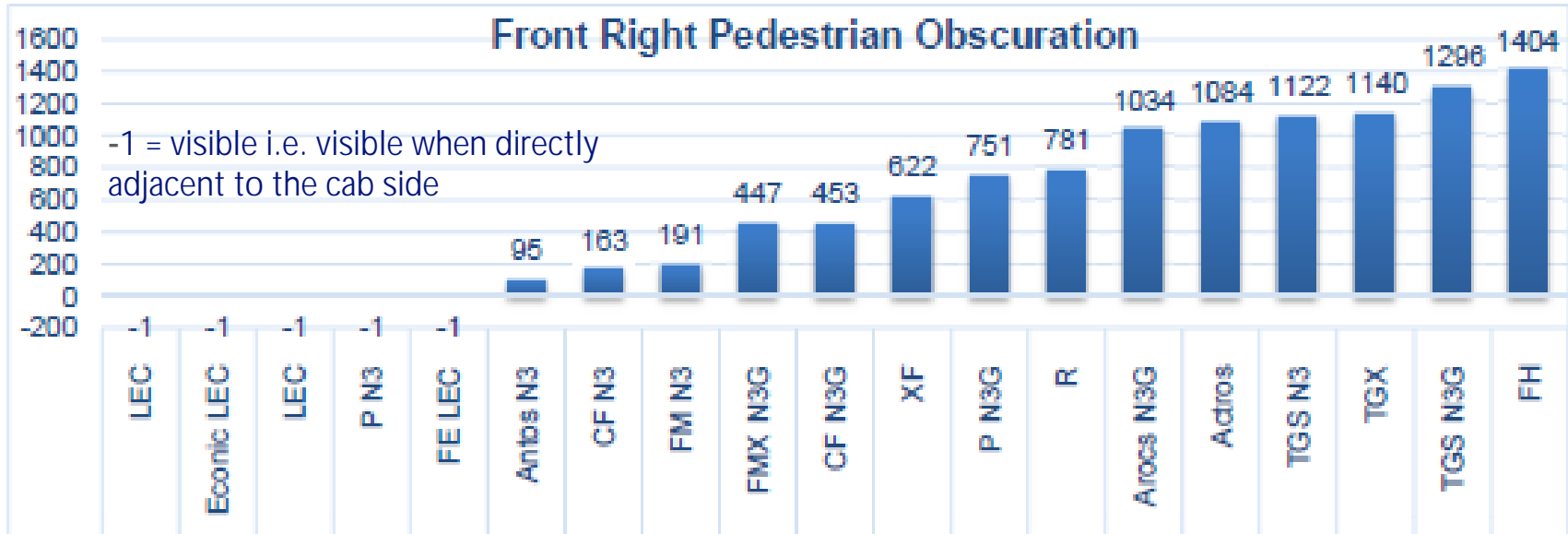
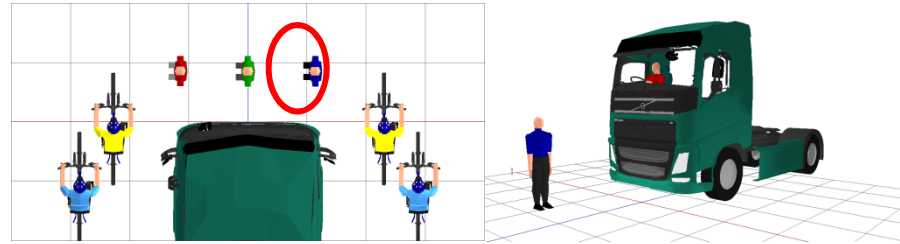

Variation in direct vision - nearside

Up to 2.5 metre difference in blind-spot

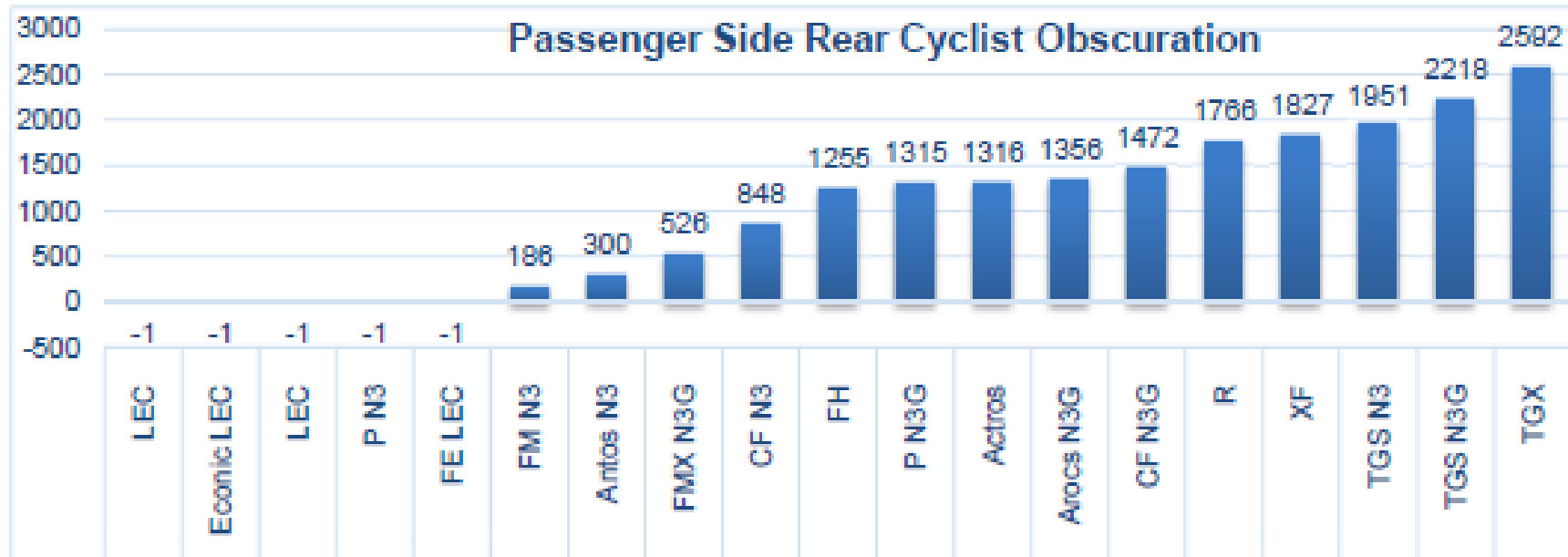
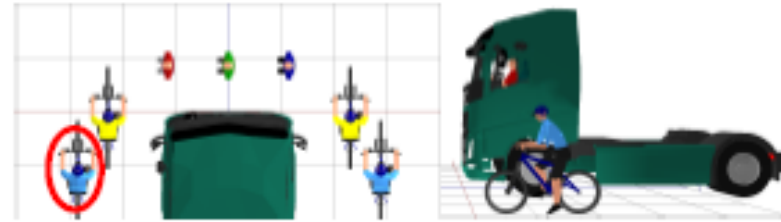

The case for Direct Vision

Exploring the road safety benefits of Direct Vision

- Understand the benefits of seeing vulnerable road users directly as opposed to indirectly
- Establish the extent to which increased direct vision could reduce driver reaction times
- Establish the extent to which increased direct vision could reduce collisions between HGVs and vulnerable road users

- 1 Literature review
- 2 Surveys
- 3 Laboratory experiments



The case for Direct Vision

1 Literature review

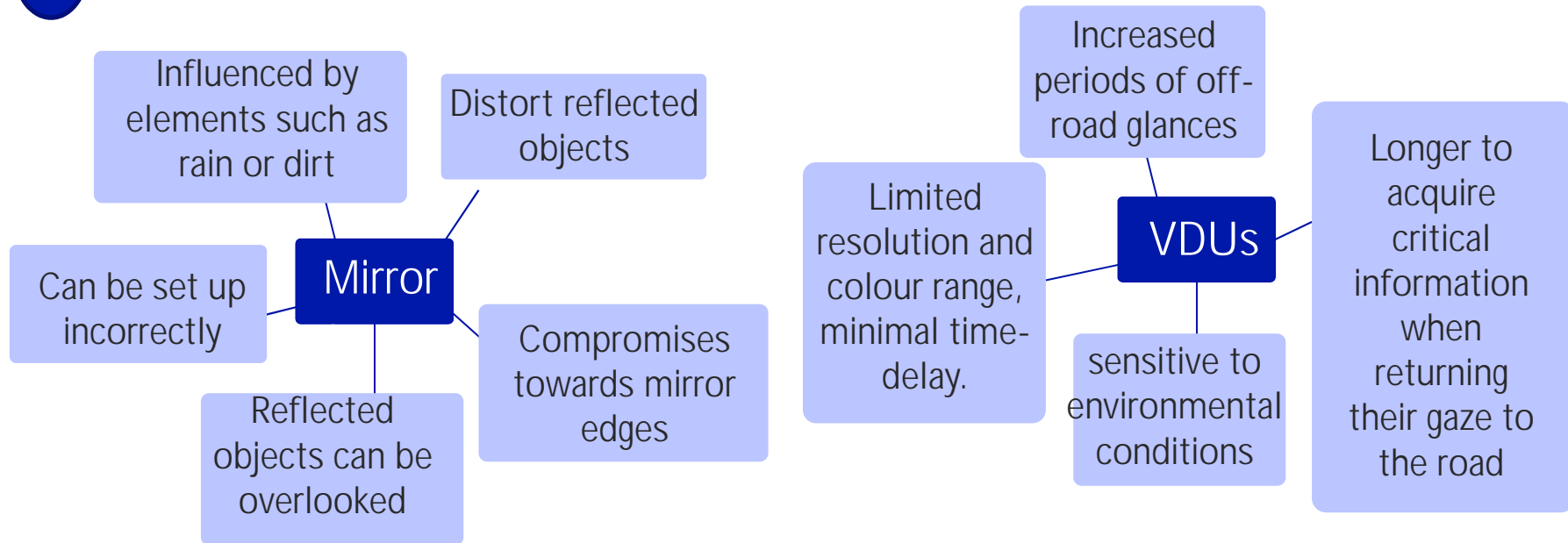

- Number of risks related to relying on mirrors for safe driving and glancing at VDUs when driving
- Increases cognitive load – put simply; its hard to think of lots of things at once
- Processing indirect visual information can result in impaired driver performance

The case for Direct Vision

2 Surveys – pedestrians, cyclists and HGV drivers



- Do not trust HGV drivers can see them through their mirrors or VDUs
 - Lower cab height and larger windows are safer
 - Eye-contact with HGV drivers makes them feel safer when passing a vehicle
-



- Do not trust HGV drivers can see them through their mirrors or VDUs
 - Agree that drivers positioned lower to the ground see them more easily
 - 86% of cyclists agree that drivers who have larger windows and 'bus style' doors see them more easily
 - Eye-contact with HGV drivers makes them feel safer
-



- Mirrors provide sufficient view - but sometimes difficult to recognise a cyclist in a mirror
- More advantages than disadvantages of VDU use
- Disagree that they are too high up to locate road users
- Most drivers try to make eye-contact with road users and believe this reduces likelihood of collision

The case for Direct Vision

3 Laboratory experiments

Indirect vision responses were on average **0.7s slower** compared to Direct viewing responses. This results in:

Speed	Extra Travel
15 mph	4.7m
10 mph	3.1m
5 mph	1.5m

Indirect vision resulted in increased incidence of **simulated** pedestrian collisions by **23%**

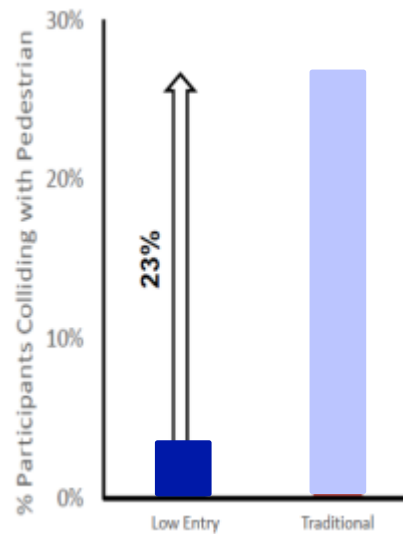

Driving whilst processing a **cognitive task** increased this incidence even further - by **40%**

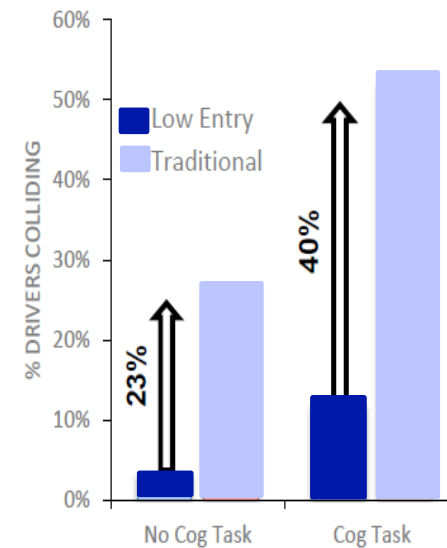

Research: Evaluation – live trials

'I feel much more confident driving in the higher vision cab. I don't want to go back to a standard tipper'



"I'd say just give it a go, it's opened my eyes. I didn't see how it could be improved before"



'You just need to sit in one of the old cabs then get in the new one to realise how important this change is'

'As a lorry driver, it pains me to say this, but its actually pretty good'



17

Safer Trucks

Link to film:

<https://tfl.gov.uk/info-for/deliveries-in-london/delivering-safely/safer-trucks>



Dynamics of the collisions – moving off

- Vehicle initially stationary:
 - Often at formal crossings, sometimes other junctions or just queues
- Pedestrian crosses from the nearside,
 - Sometimes straight sometimes initially coming from rearward of front of truck. Sometimes described as rushing to cross before lights changed
 - Usually elderly, speeds not rigorously known
 - Older suggests slower than average
 - Descriptions of rushing may counter
 - Witness descriptions almost always:
 - Driver ‘didn’t see them’
 - Pedestrian ‘couldn’t get out of the way fast enough’
- Forward separation between cab and pedestrian not often quantified in the data

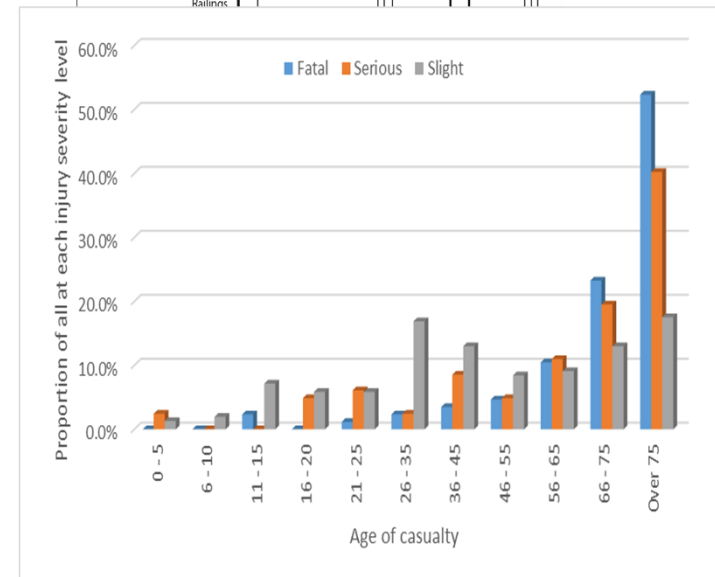
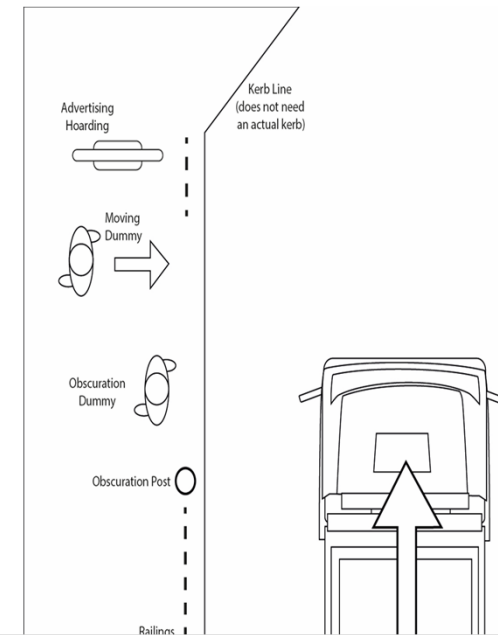

Dynamics of left turn collisions (in UK)

Type 1

- Both HGV and cycle move off from rest together. HGV Turns left.
- Impact point typically nearside front
- **c.30% of Cyclist Left turn fatalities** based on a small sample studied in depth

Type 2

- Cyclist moves up inside of stationary HGV at speed. HGV moves off and turns left
- Impact point typically nearside front
- **c.40% of Cyclist Left turn fatalities** based on a small sample studied in depth

Type 3

- HGV and cycle both moving, sometimes cycle undertaking, sometimes HGV overtaking, low relative speed. HGV Turns left.
- Impact point anywhere along full length
- **c.30% of Cyclist Left turn fatalities** based on a small sample studied in depth

Objectives of the Direct Vision Standard

The DVS is an objective measure of the volume of space visible directly by the driver. HGVs can be rated 0-5 stars where 0* is poor direct vision and 5* is excellent

It was developed for a number of uses:

Influencing purchasing decisions:

- Objectively categorises HGVs by direct vision for the first time
- Informs operator purchasing decisions so they can buy the 'best in class' vehicle fit for use in an urban environment for each application
- Encourage manufacturers' to voluntarily promote higher star rated vehicles to their customers , improve current vehicle specifications and guide future designs

Influencing regulation:

- Lobby for inclusion within future European regulations governing HGV designs

Accelerated adoption of safer HGVs in London:

- Including the DVS in procurement contracts
- Mayor's proposals for scheme to ban or restrict of vehicles with poor DVS rating



DVS development and stakeholder engagement

- The need for a DVS was identified at industry working groups governing TfL's Safer Trucks and Construction Logistics and Community Safety (CLOCS) programmes in **July 2014**
- The aims and objectives of the DVS were reviewed by a number of industry stakeholders including operators, clients of those operators and vehicle manufacturers in **March 2015**
- TRL were commissioned to develop the first iteration of the DVS, which was published in **September 2016**.
- Loughborough University was commissioned to test the TRL method in the 'real world' and begin to rate HGVs to the DVS and model Euro VI N3 cabs in **October 2016**
- Since **October 2016 we have worked with** following principal vehicle manufacturers to do this:

Volvo

Renault

Scania

Mercedes-Benz

MAN

DAF

Iveco

Dennis Eagle

- As of **June 2017** all of the manufacturers have had direct engagement with TfL and 7 of the 8 have either provided vehicle CAD data or supplied vehicles to carry out the ratings



Definition and testing of a Direct Vision Standard for Trucks

Loughborough University Design School: Design Ergonomics Research Group
[Research Sponsored by Transport for London](#)

Dr. Steve Summerskill

Dr. Russell Marshall, Dr Abby Paterson, Antony Eland, James Lenard, Steve Reed

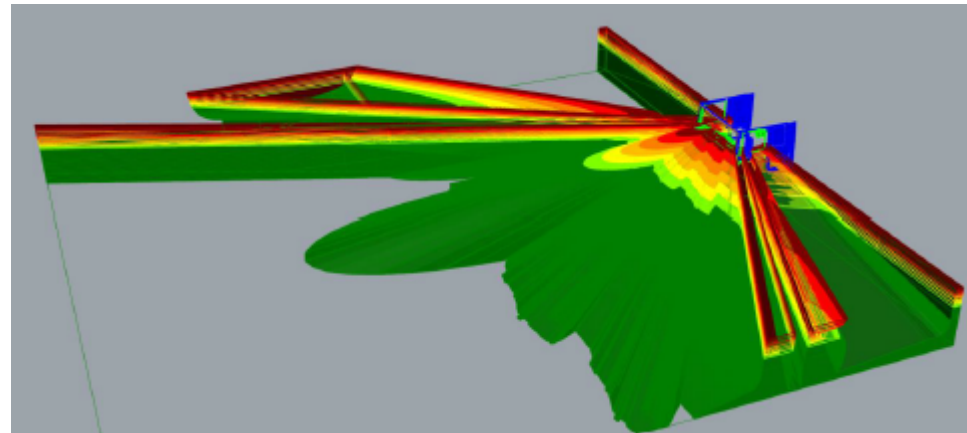
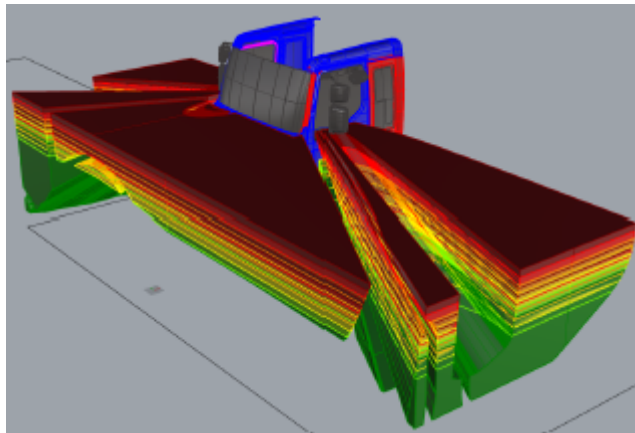

Contents

Detailed review of the work performed so far

- Previous work
- Accident data analysis summary
- Definition of the assessment zones
- The candidate weighting schemes used in the analysis
- The process of performing the analysis
- Sample of vehicles used
- The use of VRU simulations as a real world measure

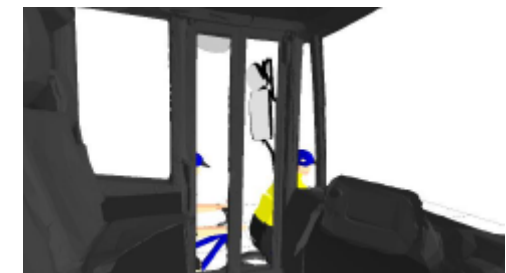
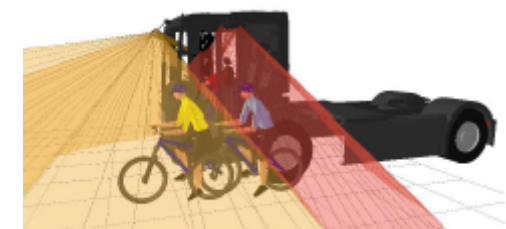
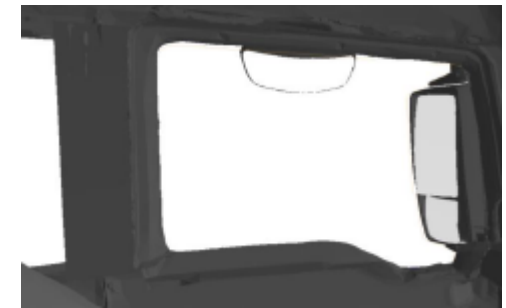
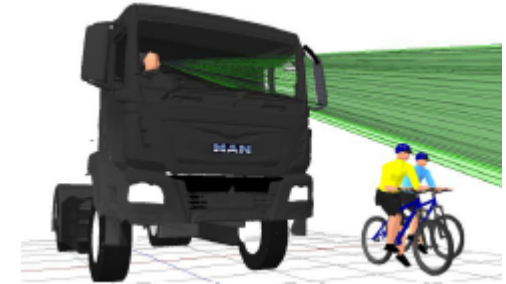

Previous experience of the Design School team – leading to the definition of need for a Direct vision Standard (DVS)

Background - DfT Project 2010-2012

Using Digital Human Software to simulate and quantify blind spots

- This technique was successfully used to identify a key blind spot next to the drivers cab
- The LDS team then supported the DfT in the definition of a revision of the United Nations Economic Commission for Europe Regulation 46 which specifies mirror coverage
- We acted as the UK experts at the 100th UNECE GRSG meeting which led to a revision of UNECE Regulation 46 to increase the required area of mirror coverage

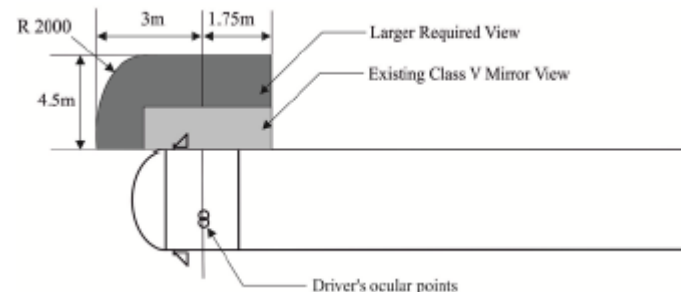

This change was applied to all new vehicles from July of 2015

Background – TfL Project 2013-2015

Assessing the vehicle fleet to determine the differences and highlight blind spot design features

- 19 vehicles modelled and tested to determine their blind size variability and design features which cause that variability.

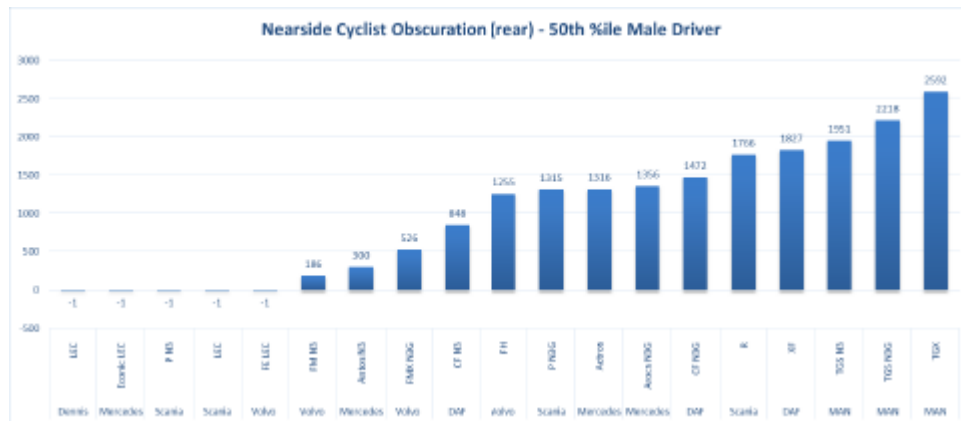

Results TfL Project 2013-2015 – Example of exploring the important design variables

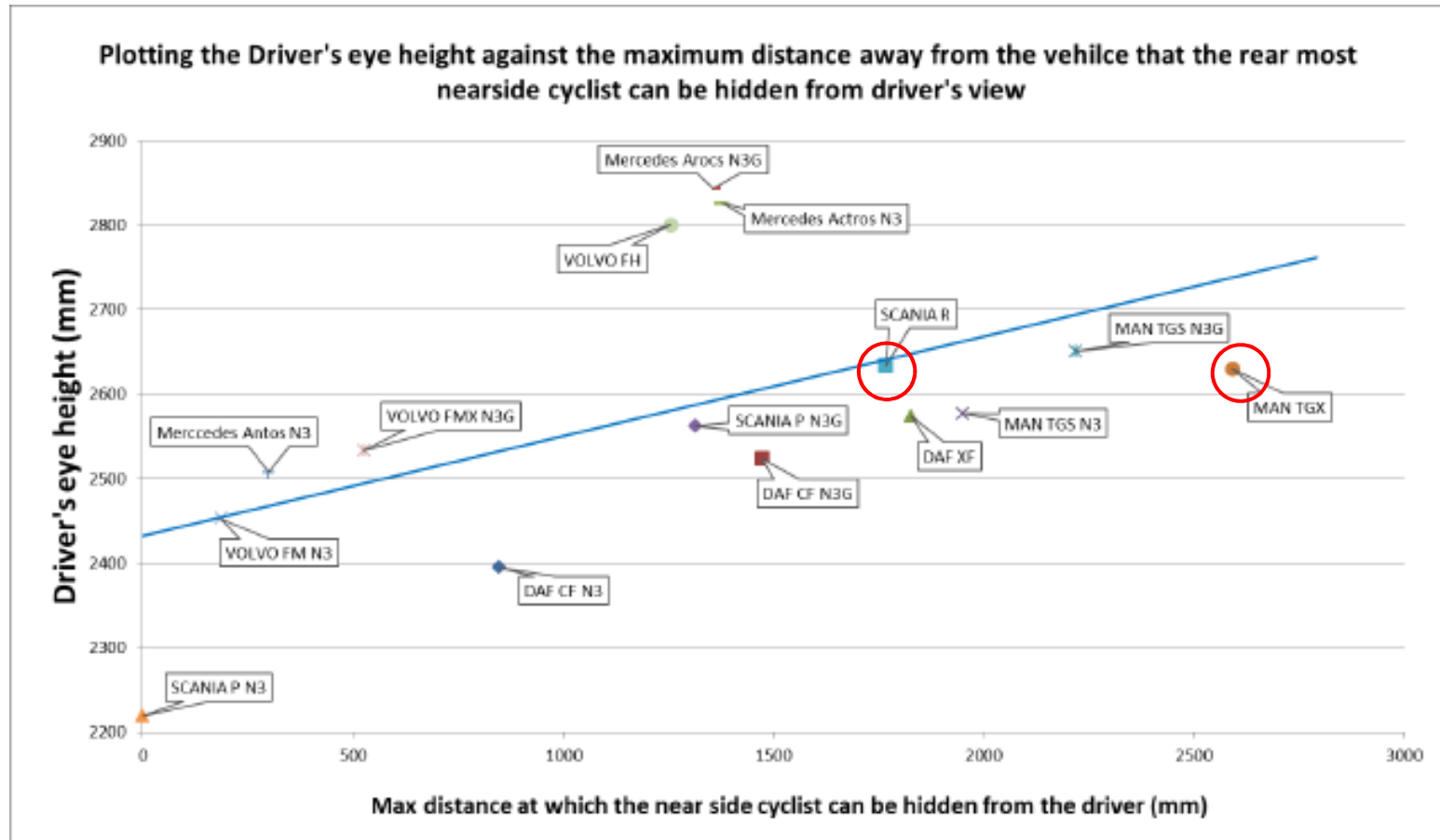

- *This means that there is a link between the eye height of the driver above the floor and the maximum distance that a cyclist can be hidden to the near side*
- There were however some anomalies which required further investigation to allow key design features to be identified

Results TfL Project 2013-2015 – Example of exploring the important design variables

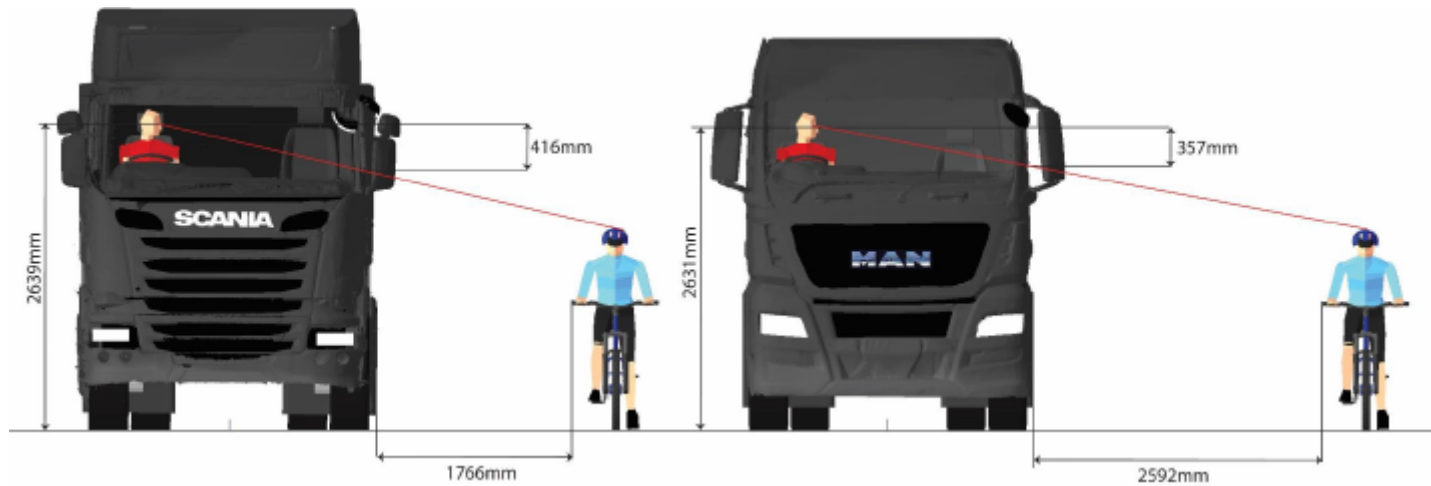

- MAN TGX has a lower driver eye height above the ground, but the cyclist is fully hidden further away from the vehicle when compared to the Scania R
- This is due to the drivers eye point being relatively higher above the window sill in the Scania R

Results TfL Project 2013-2015 – Example of exploring the important design variables



Scania R

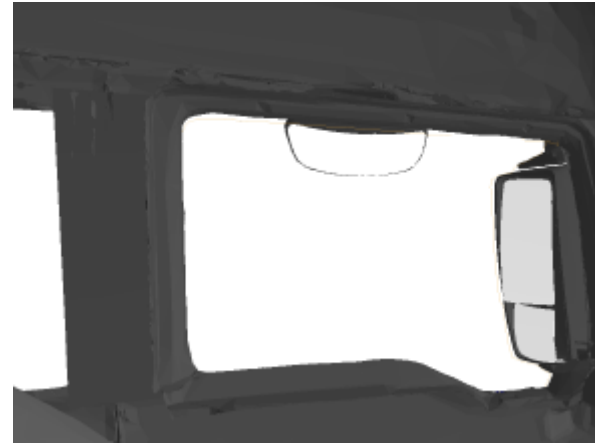

MAN TGX

- Driver's eye views of the passenger window
- The higher window sill at the rear edge of the window in the MAN TGX reduces the field of view in this critical area
- **This project defined the need for a [Direct Vision Standard](#)**

Direct vision Standard (DVS)

How the standard will work

- Predefined assessment volumes will be placed around a truck
- The percentage of those assessment volumes that cannot be seen by a driver will be subtracted
- The remainder will be used to calculate the rating for the vehicle
- Weightings have been explored that account for common accident locations based upon analysis of the UK STATS 19 database

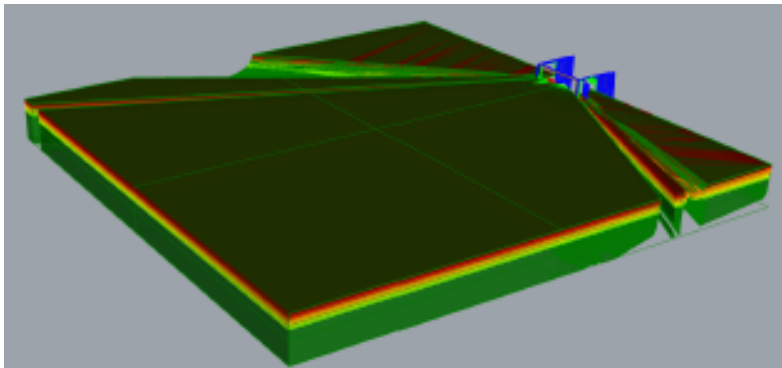

How the standard will work

- The Draft DVS produced by TRL has now being developed and refined by the LDS
- The following slides outline the process that has been performed to date

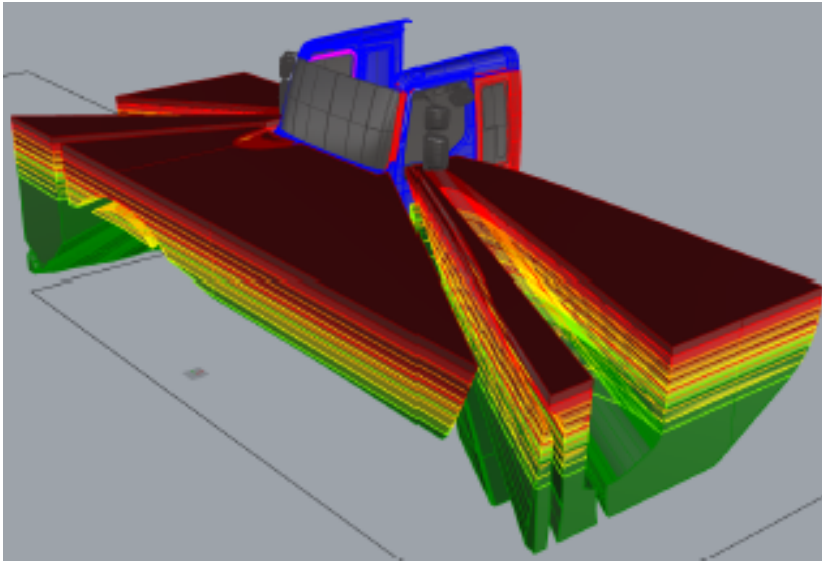

Accident data review to define the areas of greatest risk

34 DVS Standard: Reviewing the standard definition – Area of greatest risk

- The analysis of the UK accident database (STATS 19) for accidents between Vulnerable road users and HGVs above 7.5 tonnes has been performed
- This analysis was performed for all accidents between 2010 and 2015.
- Nationally this involves 2443 accidents
- Each accident is categorised and recorded by a police office using the STATS 19 form accident recording form which is used when someone has been injured or killed on the highway
- The manoeuvre is recorded as well as the contributory factors.
- There are numerous accident categories including data on accident causation which had to specially requested by the accident data analyst
- Analysis has been undertaken on those collisions whereby the visibility or the blindspot may have played a role

DVS Standard: Defining the candidate weighting scheme – ‘Area of greatest risk’

- The accident data allows us to weight the importance of vision around the truck by;
 - Using the data on the first point of contact between a HGV and vulnerable road user during an accident
 - Or
 - Using the data which tells us the manoeuvre that the vehicle was making during the accident
- The image to right shows the importance weighting based upon first point of contact for all accidents where “blind spot” was listed as a contributory factor
- The exploration of weighting the data highlighted that this **did not improve vehicle differentiation.**

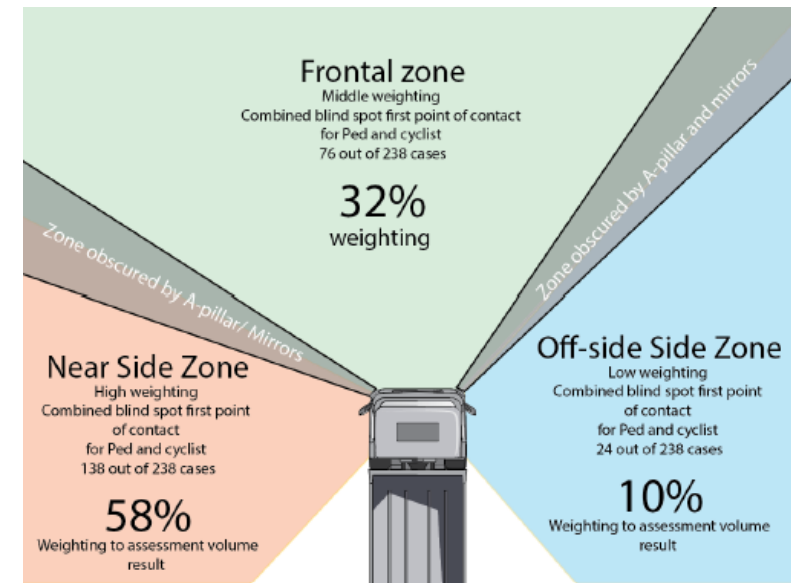

Application of weightings to the results

- The accident data has been useful in highlighting the nature of accidents, the strong link with blind spots as per the contributory factors data and highlighting issues such as the proportion of the older population that are involved in accidents involving pedestrians
- Weightings have the potential to direct redesign effort to the area of greatest risk
- There are however potential issues with the use of accident data
 - The data available is a relatively small sample
 - The long term of benefits of using weightings based upon accident data which may change based upon the intervention of the standard is questionable
 - See later for a comparison of the results with and without accident data weightings

Assessment zones definition

How the standard will work – Full height range and look-up tables

- New features of the DVS standard and its definition process that have been specified by the LDS team
- The height at which a cab is mounted in a vehicle above the ground is a key variable associated with the performance of a design in the DVS rating system
- A cab can vary in height due a number of specified features such as tyre type, suspension type and axel configuration
- The initial proposal for the DVS standard definition process was defined as testing existing vehicles with cabs mounted at their **most sold heights**
- This has now been expanded to include the **maximum mounting height**, **minimum mounting height**, the most sold height, and **increments between the maximum and minimum mounting heights**
- This allows a look up table to be produced for each cab design
- By taking measurements from an existing cab (the height of cab floor behind the accelerator pedal) the rating of an existing vehicle can be determined using the look up table
- Manufacturers have had the opportunity to review and make comment on this proposal after the stakeholder meeting in March of 2017.

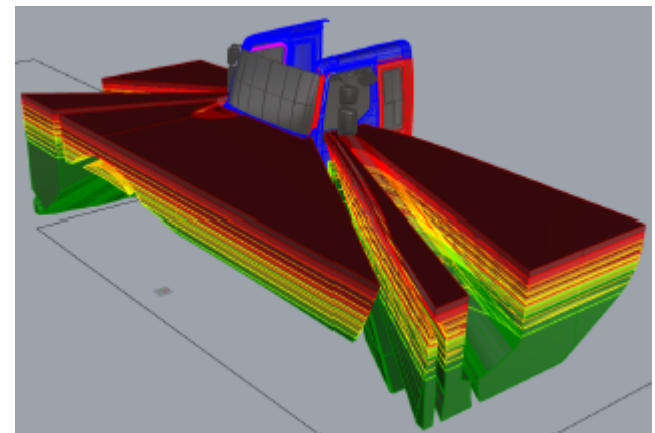
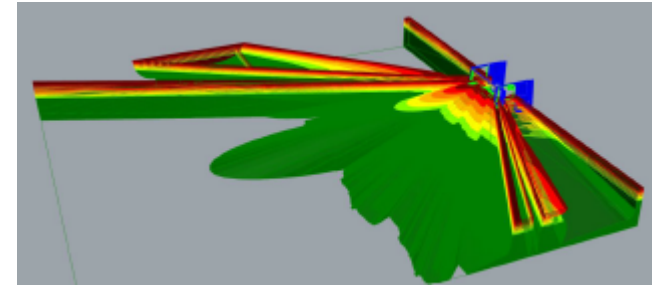

Assessment zones used in the analysis

Example: Visibility Assessment Zones – Candidate 1 trimmed

- The premise of this candidate is that any vehicle which does not allow visibility of the defined VRU outside of the mirror coverage zone is performing badly as people can fit in the blind spot.
 - The zones have no offset from the edge of the vehicle to avoid any issue of how small a VRU could be
 - The zone extends to the nearside by 4.5m to replicate the Class V mirror zone
 - The zone extends to the front of the vehicle by 2m to replicate the Class VI mirror zone
- Based upon UNECE reg 46 values

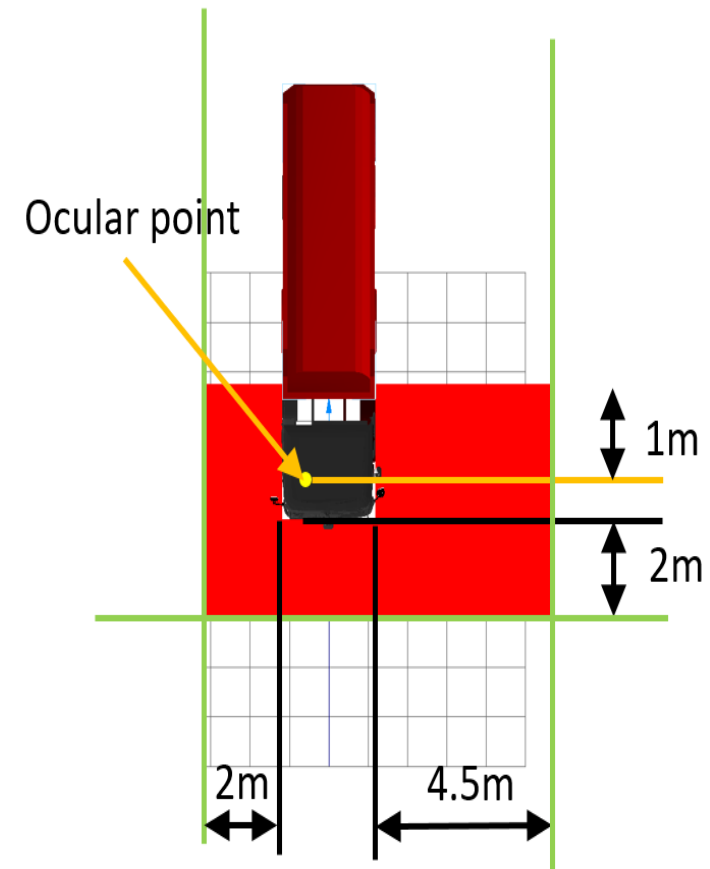

Example: Visibility Assessment Zones – Candidate 1

- The zones around the vehicle consist of six horizontal layers
- The layers are split to recognise the variation in the size European population and to provide coverage to the ground plane
 - This has benefits of transparency, including all VRUs in the definition, including children
- The zones extend between:
 - 1.177m above the ground plane – defined by the shoulder height of a 5th %ile Italian female
 - 1.605m above the ground plane – defined by the shoulder height of a 99th %ile Dutch Male
 - The premise is that seeing the head and shoulders of a person will allow them to be recognised by the driver

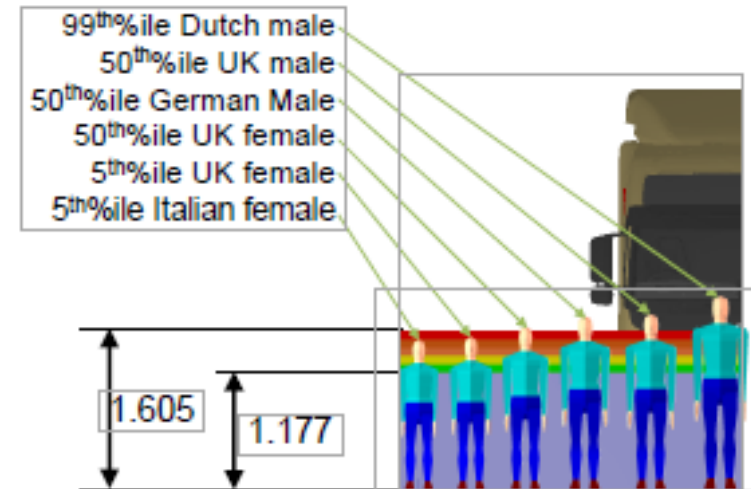

Defining the assessment procedure

DVS Standard: Defining the assessment methodology in terms of eye points and projection types

- We have held detailed discussions about the application of the TRL draft version of DVS with a number of manufacturers, and met with all manufacturers to discuss the concept and changes to the TRL proposal
- This has highlighted the importance of an expedient but accurate assessment method for the DVS as manufacturers will have high number of design variants to test during the development phase of a vehicle design

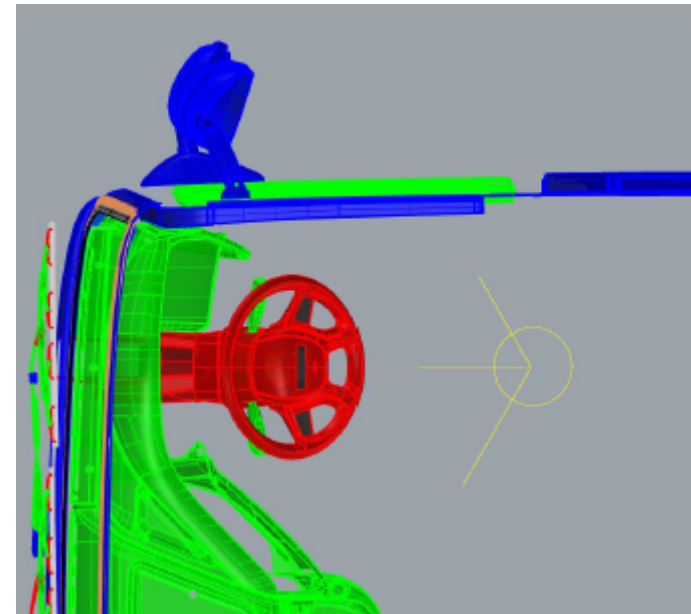

DVS Standard: Defining the assessment methodology in terms of eye points and projection types

- The proposal at this stage it to define the eye point using method defined in UNECE Reg 46
 - 635mm above the R point (SgRP)
- And using the method defined in UNECE Reg 125 to define a neck point and head rotation.
 - 60 degrees to the left and right of central vision about the defined neck point
- With **monocular vision** any glazed area rearwards of the A-pillar (nearside and offside) will be projected using an eye position and with the eye looking in the corresponding direction, and the forward view through the windscreen will be projected with the eye facing forwards
- See figure. e.g. The drivers side window is projected using the eye shown in bottom two images.
- In this way the complexity of projecting multiple eye points as per the ambinocular method is reduced as the projections for both eyes do not need to be combined

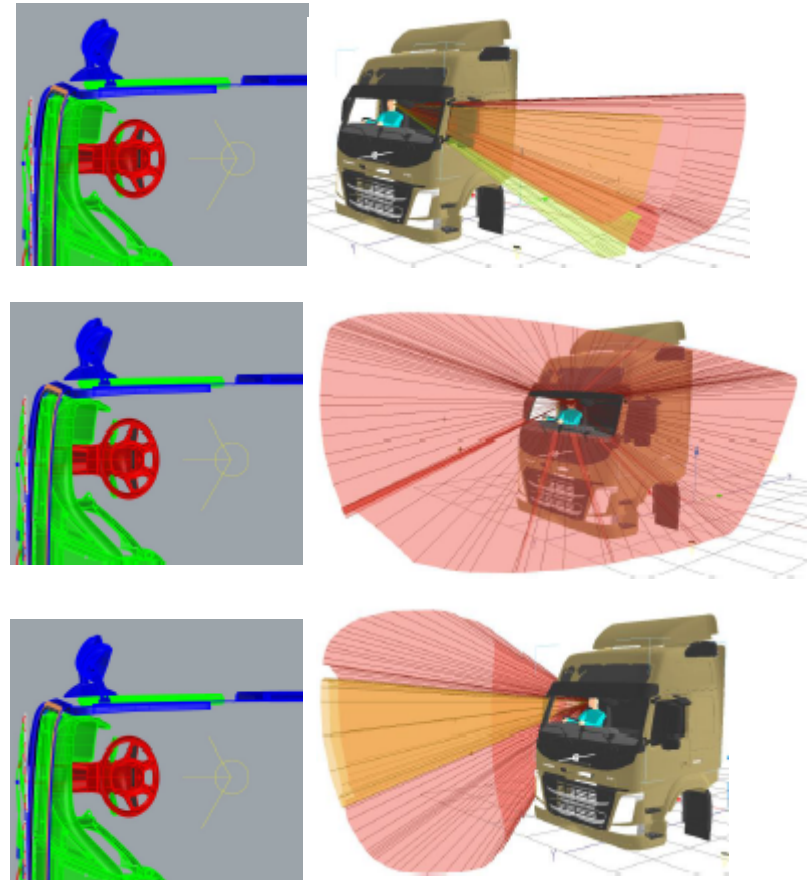

DVS Standard: Defining the assessment methodology in terms of eye points and projection types

- What can be seen from the defined eye point is being projected using the MESHOUTLINE tool in the CAD software Rhino
- This allows a path to be defined which can be used to define a visible volume of space which can then be subtracted from the assessment zones to define the score for the vehicle
 - This is the same process that was performed in SAMMIE CAD in the previous project (TfL, 2015)
- The weightings discussed above can be then applied to each zone
- As we are calculating the volume of the assessment zone which can be seen through the windscreen and side windows separately, the weighting for accident severity derived from the accident data can be applied to these separate zones to give an overall rating for each vehicle

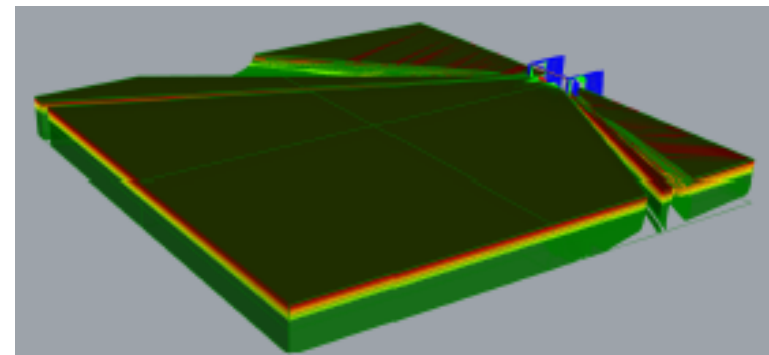
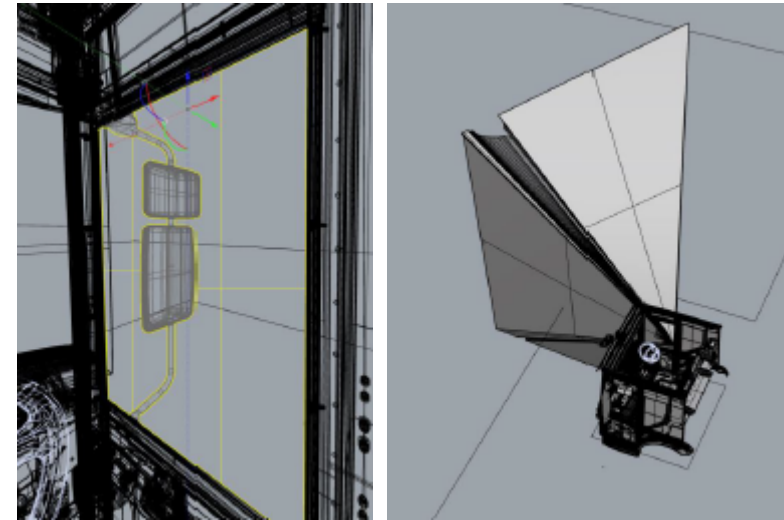

Volumetric results (in performance order, no link to previous table)

Volumetric results for Candidate 1 Trimmed in order of performance (higher is better)

- With a set of volumes defined we needed a method by which we could assign certain volumes to certain star ratings
- A simple subdivision of the results would not relate to the real world problem that the DVS is trying to address
- Therefore the following slides show how we linked the volumetric results to the real world

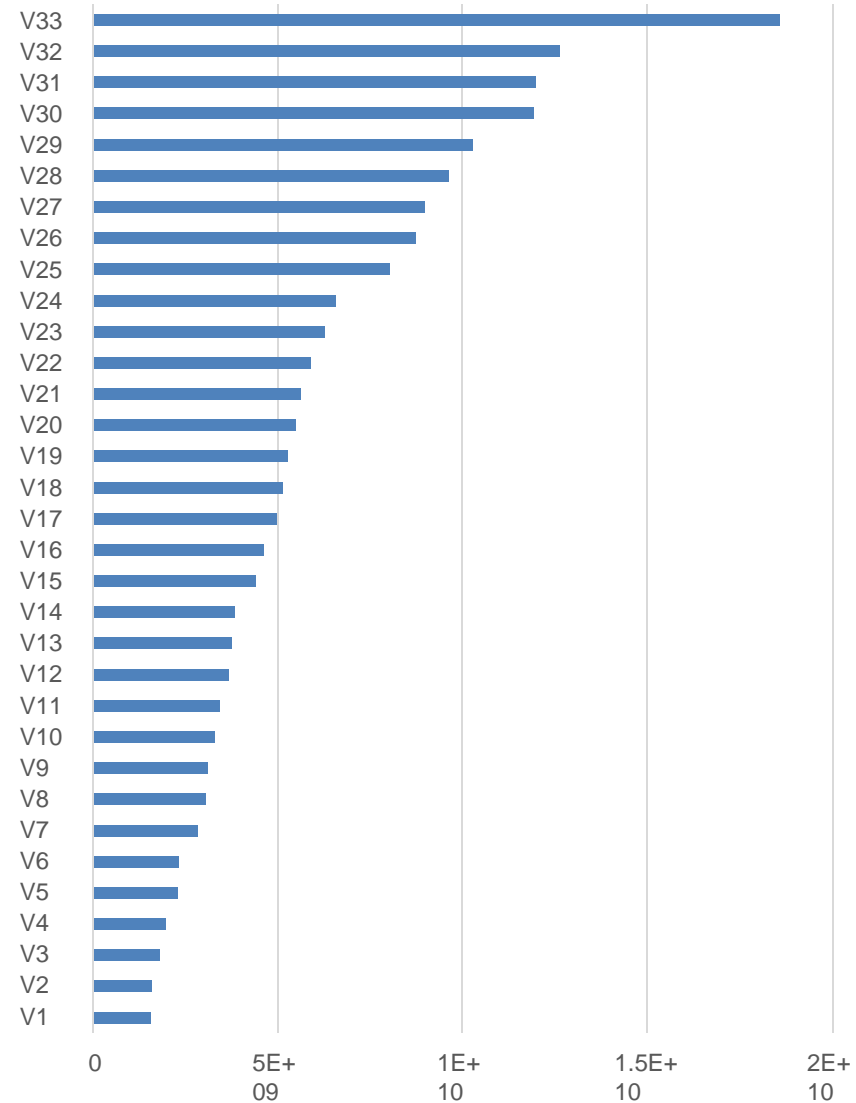

Quantifying the volumetric results

Quantifying the volumes against real world performance

- A number of VRU simulations were created and orientated around the vehicle
- The distance at which the head and shoulders of the VRU could be seen to the sides and front of the vehicle were calculated and correlated with the volumetric results

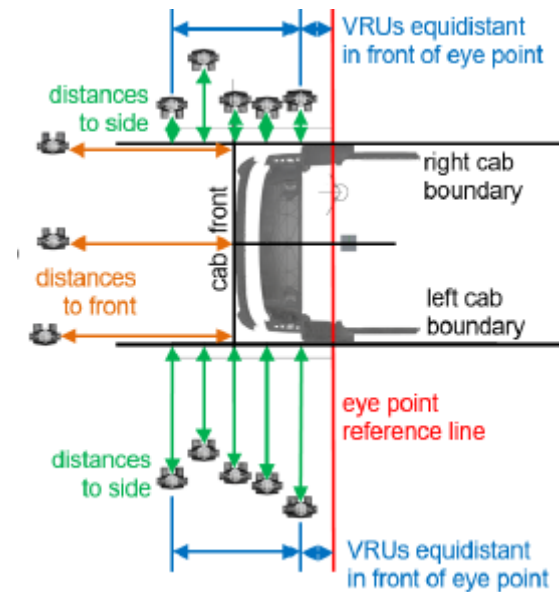
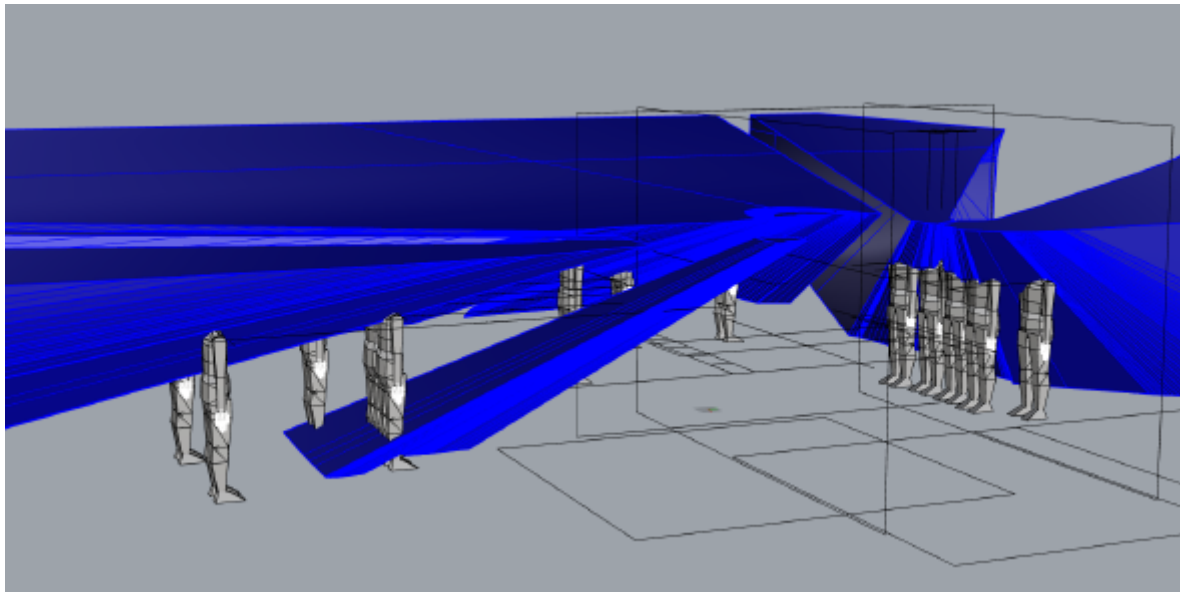

Quantifying the volumes against real world performance

- This use of the potential VRU heights makes an assumption that seeing the head and shoulders is sufficient to allow recognition by a driver
- We have opted to use the 5thile Italian female as the key VRU
- This means that the full European population is covered by the standard (-5% of Italian females)
- **Therefore if the head and shoulders of the smallest European female (apart from 5% of Italian females) can be seen then in theory the whole adult population of Europe can be seen.**

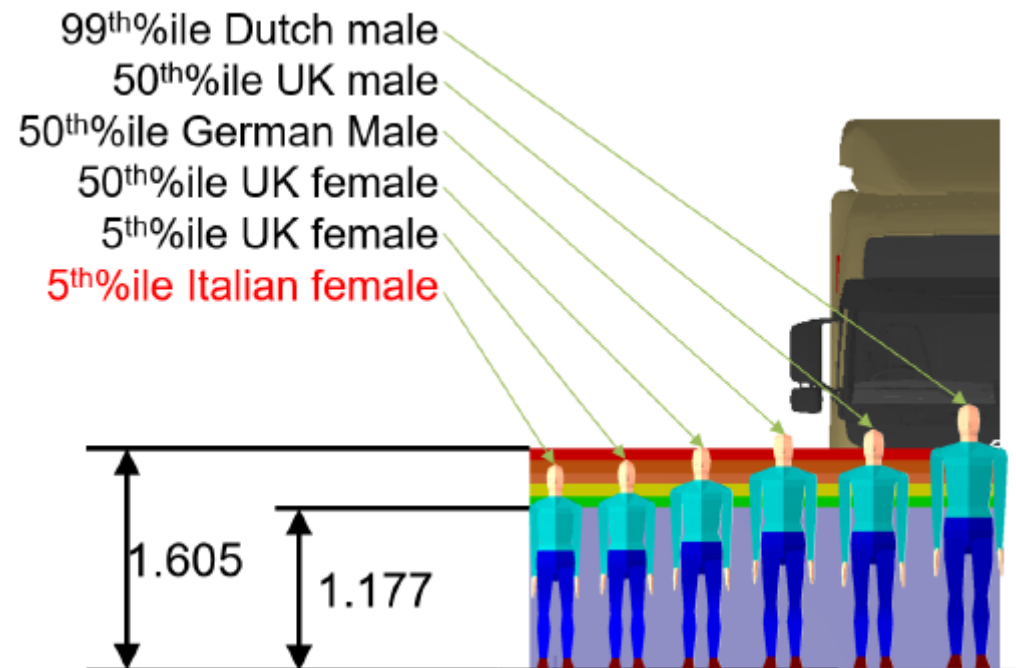

Quantifying the volumes against real world performance

- The boundaries of the cab are identified to the front, left and right
- 5 VRUs (5th %ile Italian female pedestrian) are positioned to left and right, and 3 VRUs to the front
- VRUs to the sides are positioned head of the eye point in equal increments extending into mirror obscuration zones
- VRUs to the front are positioned on the centreline of the cab at to either side
- Distances from the shoulder line to the front / side recorded

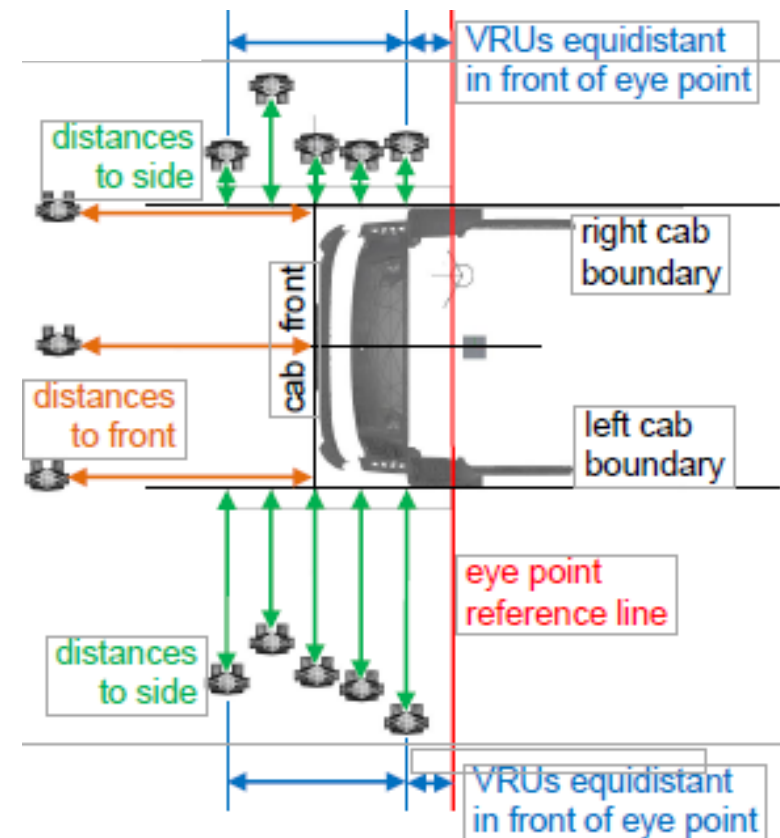

Quantifying the volumes against real world performance

- As expected there is a strong (0.87) correlation between the VRU distances and the volumes visible
- This allows the distances to be used to illustrate the meaning of the star rating boundaries
- For example, a 5 star vehicle allows a pedestrian to be visible to the near side at a distance between 0m and 1m

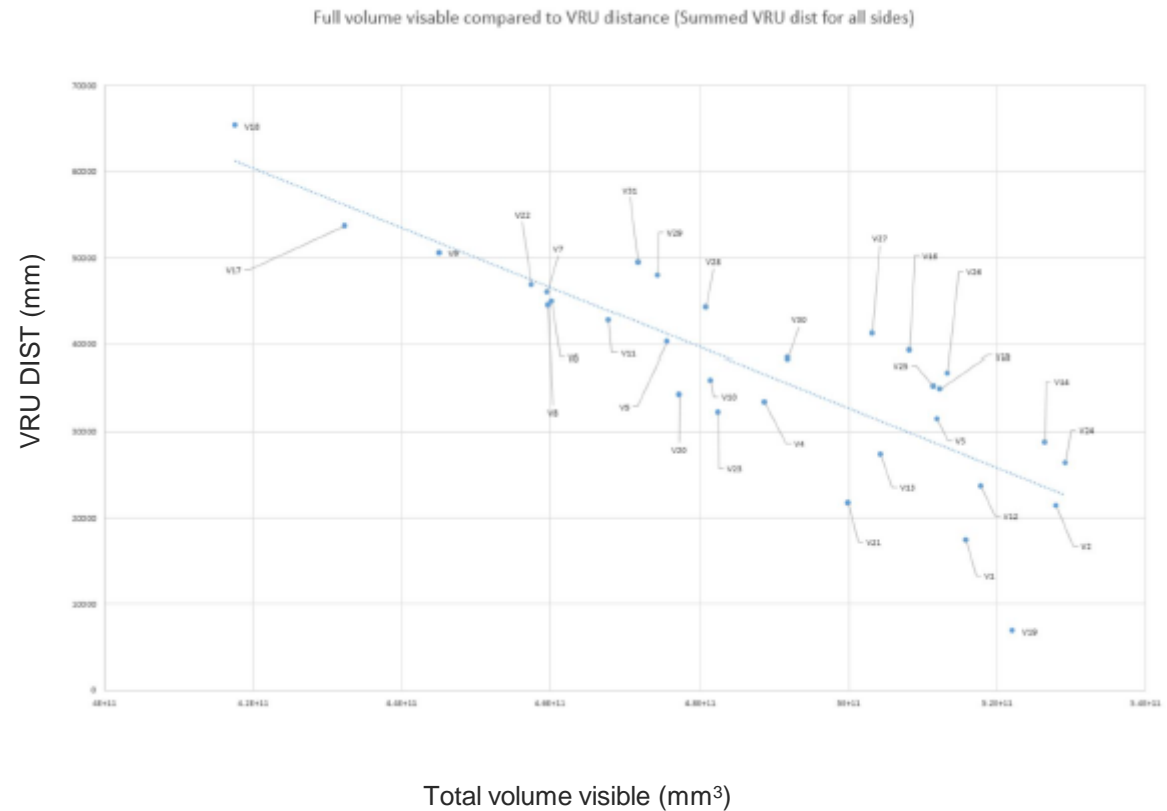
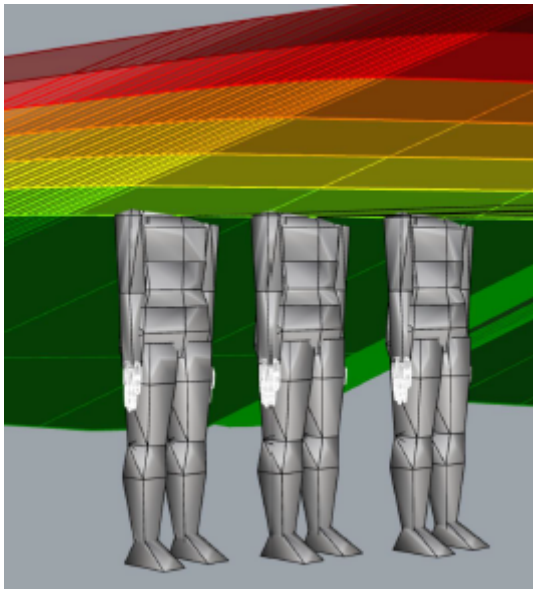

Quantifying the volumes against real world performance

- The aim here is not have a VRU location assessment as part of the DVS
- Instead we are using the VRU distance results for the sample of 33 vehicles to quantify the performance of the sample, and support the definition of the star rating system
- The presentation of the anonymised results this afternoon will show how the VRU distances have been used to define the 3 star rating

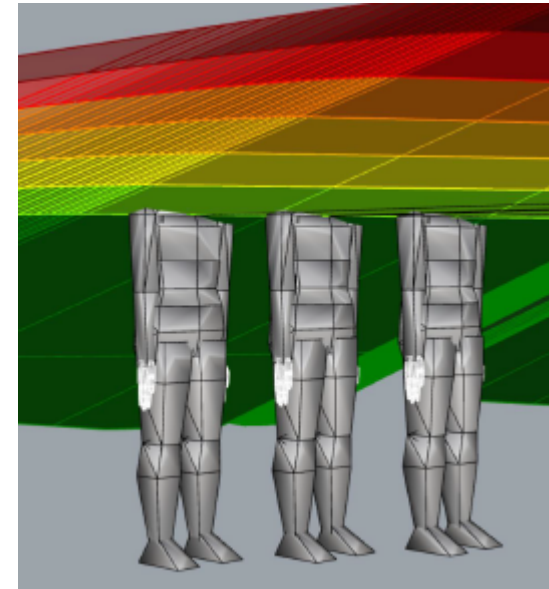

Summary

- The volumetric results have been produced for a sample **of 33 vehicles** for the candidate 1 trimmed assessment zone
- We have used the distance away at which the head shoulders of 13 VRUs can be visible to the driver in specific locations with reference to the cab
- This has allowed us to correlate the volumetric results to the VRU locations which gives a real world measure of performance

The initial graphs which compared the VRU distance (all sides Summed) to the full volume that was tested (Candidate 1 trimmed)

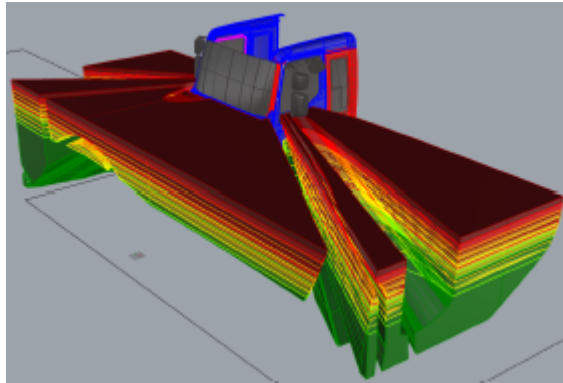

2m x 4.5m assessment volume (smallest of 2 used)

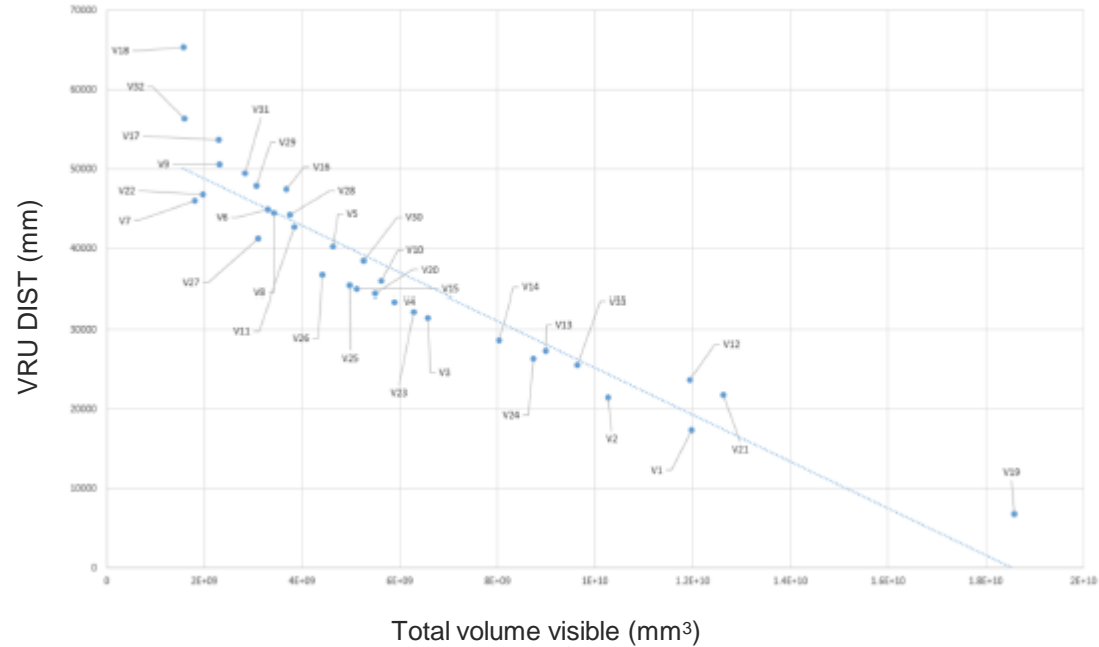
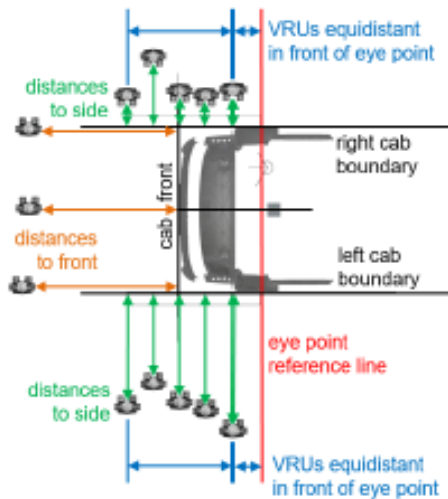

The initial graphs which compared the VRU distance (all sides Summed) to the full volume that was tested (Candidate 1 trimmed)

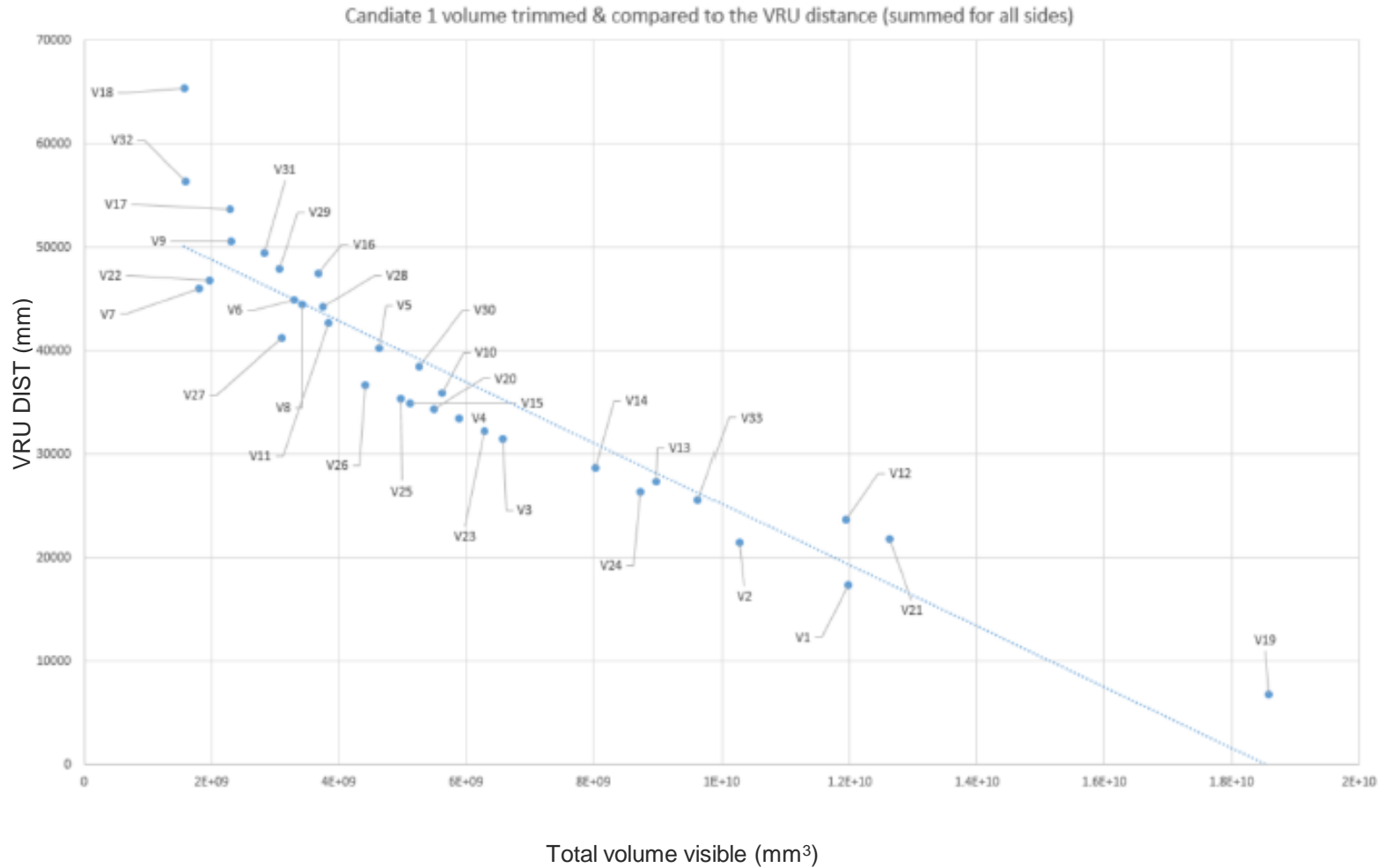

The initial graphs which compared the VRU distance (all sides Summed) to the full volume that was tested (Candidate 1 trimmed)

- Much better differentiation between the designs using the smaller assessment method
- Better capability to differentiate between designs using sets of VRU distances as star rating boundaries
- However, we did say that we would look at the effects of weighting the volumes by accident data and by the height of the VRU by assigning weightings to each of the coloured bands

Candidate 1 volume trimmed & compared to the Summed VRU distance for all sides

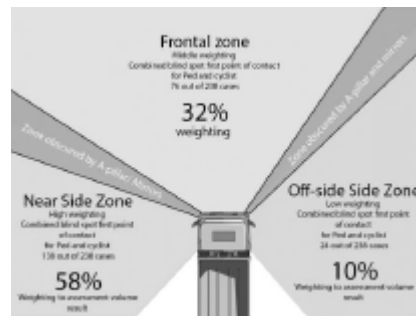
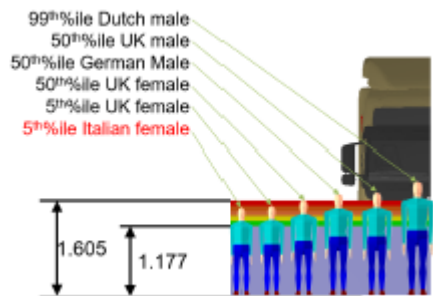
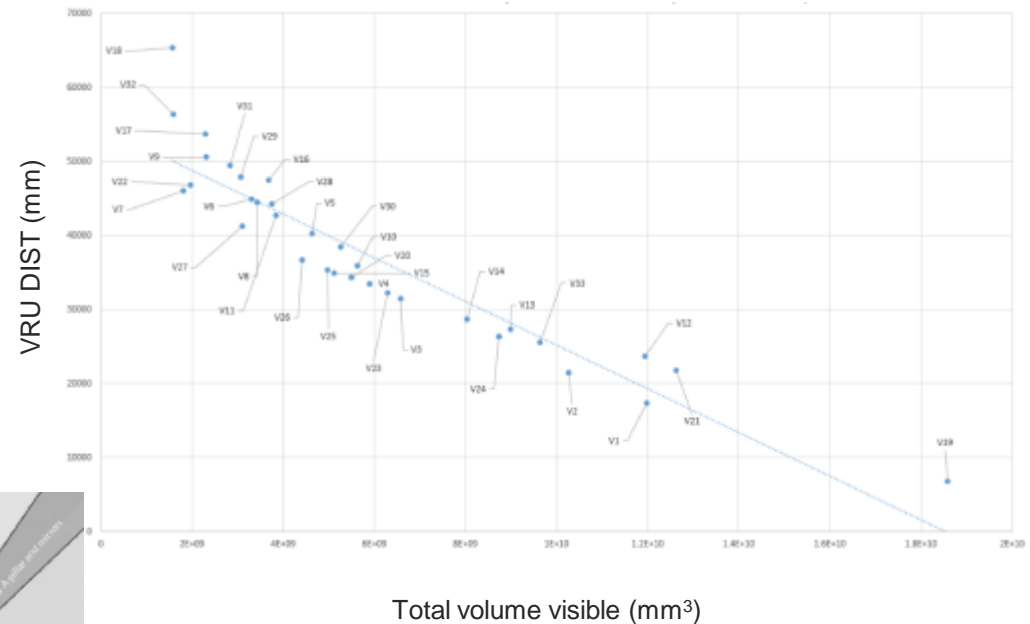

VRU distance (all sides Summed) to the **weighted 'by accident data' volume (Candidate 1 trimmed)**

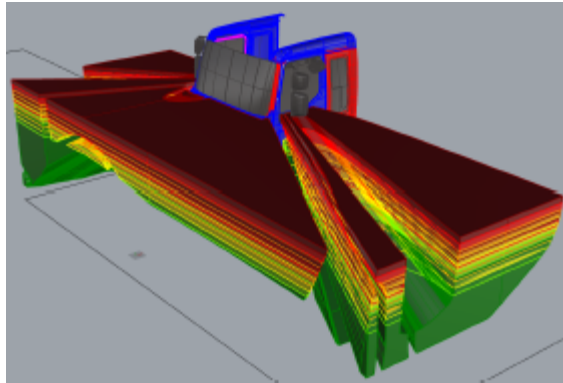

2m x 4.5m assessment volume (smallest of 2 used)

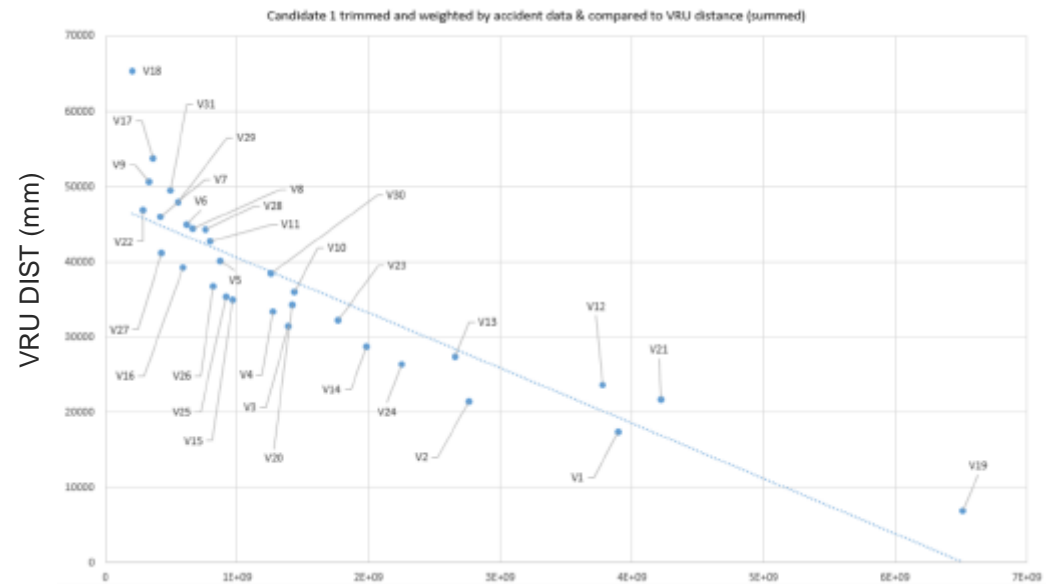
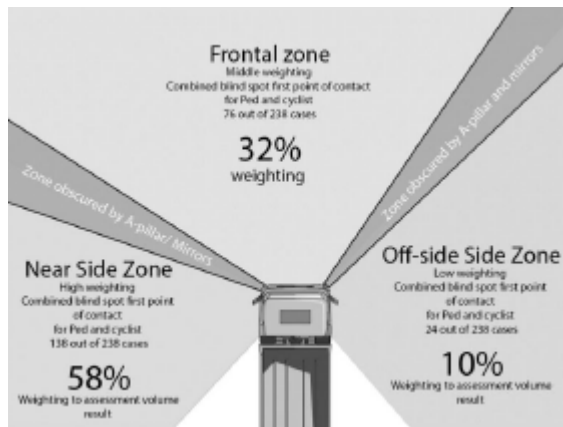

Total volume visible (mm³)

- We also tried a 45% (near side zone) 45% (Front zone) and 10% (off side zone) with similar results to the above

VRU distance (all sides Summed) to the **weighted 'by accident data'** volume (Candidate 1 trimmed)

- Results clustered to the left hand side of the graph as the due to the weighting which makes differentiation more difficult – worse performing trucks clustered together
- Non-Weighted
- Weighted

Candidate 1 volume trimmed & compared to the Summed VRU distance for all sides

Candidate 1 volume trimmed and weighted by accident data & compared to the Summed VRU distance for all sides

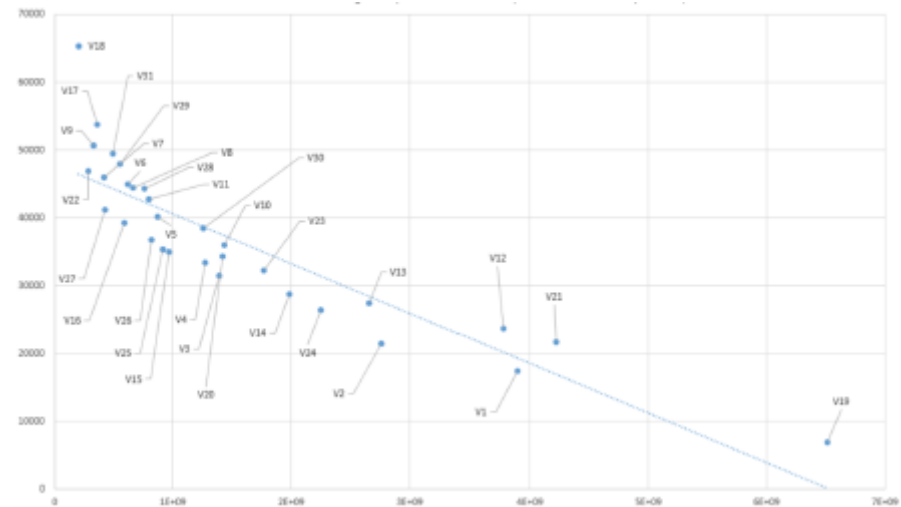
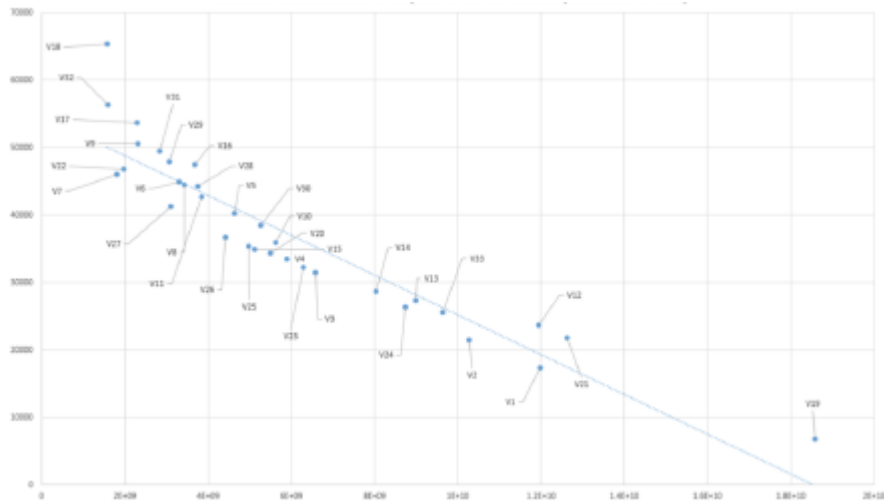

VRU distance (all sides Summed) to the height weighted volume (Candidate 1 trimmed)

- Weighted so that each vertical zone is twice as important as the one above it.

Dark Green	Green	Yellow	Gold	Orange	Red
0.507937	0.253968	0.126984	0.063492	0.031746	0.015873

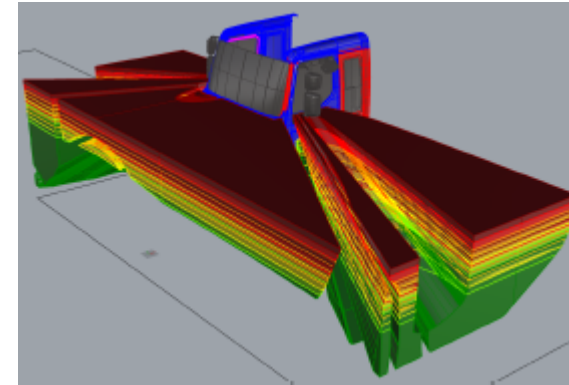

2m x4.5m assessment volume (smallest of 2 used)

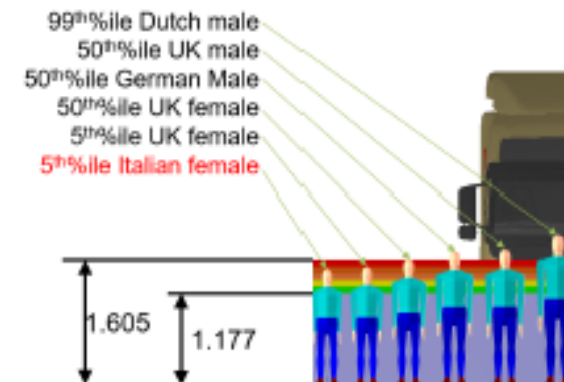

VRU distance (all sides Summed) to the height weighted volume (Candidate 1 trimmed)

- Results clustered to the left hand side of the graph as the due to the weighting which makes differentiation more difficult – worse performing trucks clustered together
- Non-weighted

Candidate 1 volume trimmed & compared to the Summed VRU distance for all sides

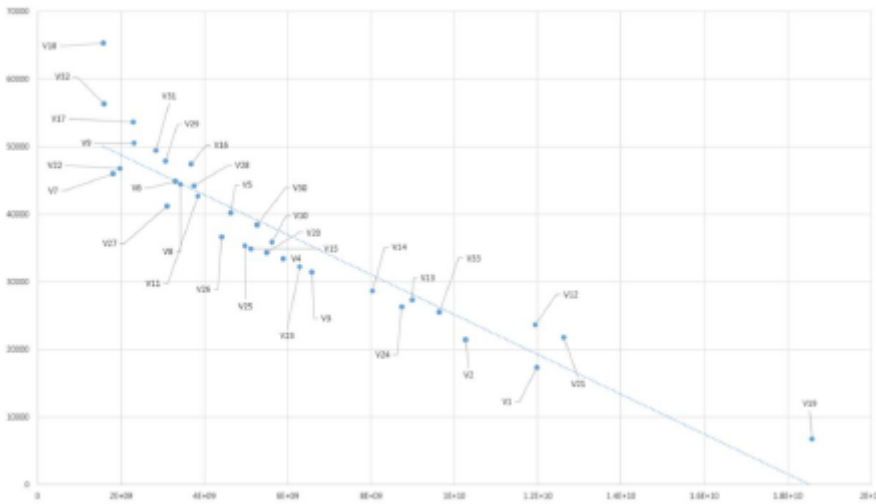

- Weighted

Candidate 1 volume trimmed and weighted by height & compared to the Summed VRU distance for all sides

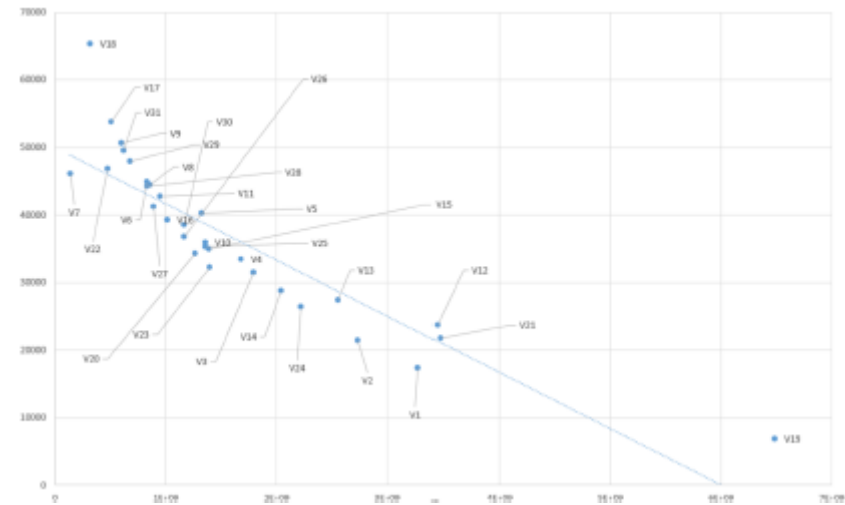

Proposal: to use a *non-weighted* volume (candidate 1)

- Therefore weighting does not help to differentiate between vehicle designs
- We propose using the non-weighted version below

Candidate 1 volume trimmed & compared to the Summed VRU distance for all sides

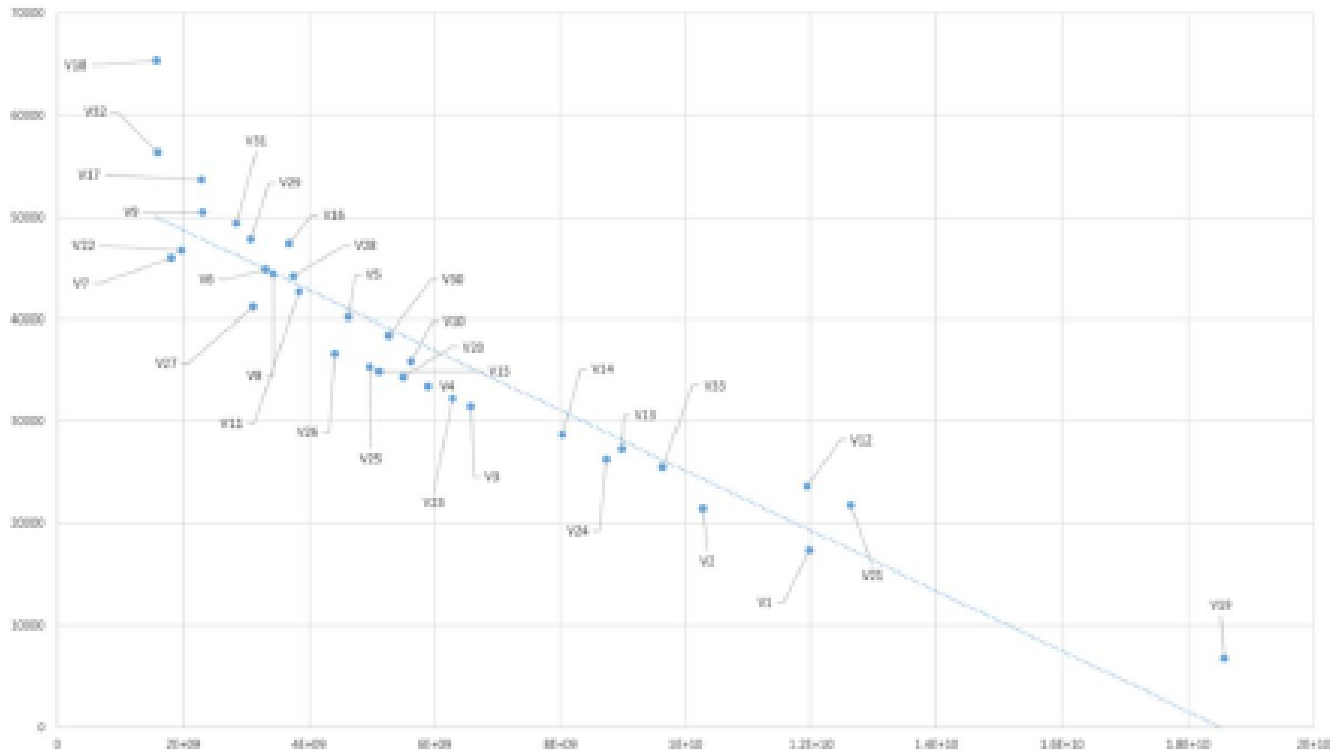

Example: Identification of boundaries

- We examined the data for the VRU results in order to define a test that was seen as a cut off for direct vision (zero star)
- We defined one test where the average distance of VRUs (3 to the front and 5 to the left) of whom the head and shoulders can be seen is greater than 4.5m to the passenger side and 2 m to the front, the vehicle fails.
- This is because a vehicle that fails this test would have blind spots between the volume of space covered by direct vision and that covered by the indirect vision through the mirrors which can hide the example VRU

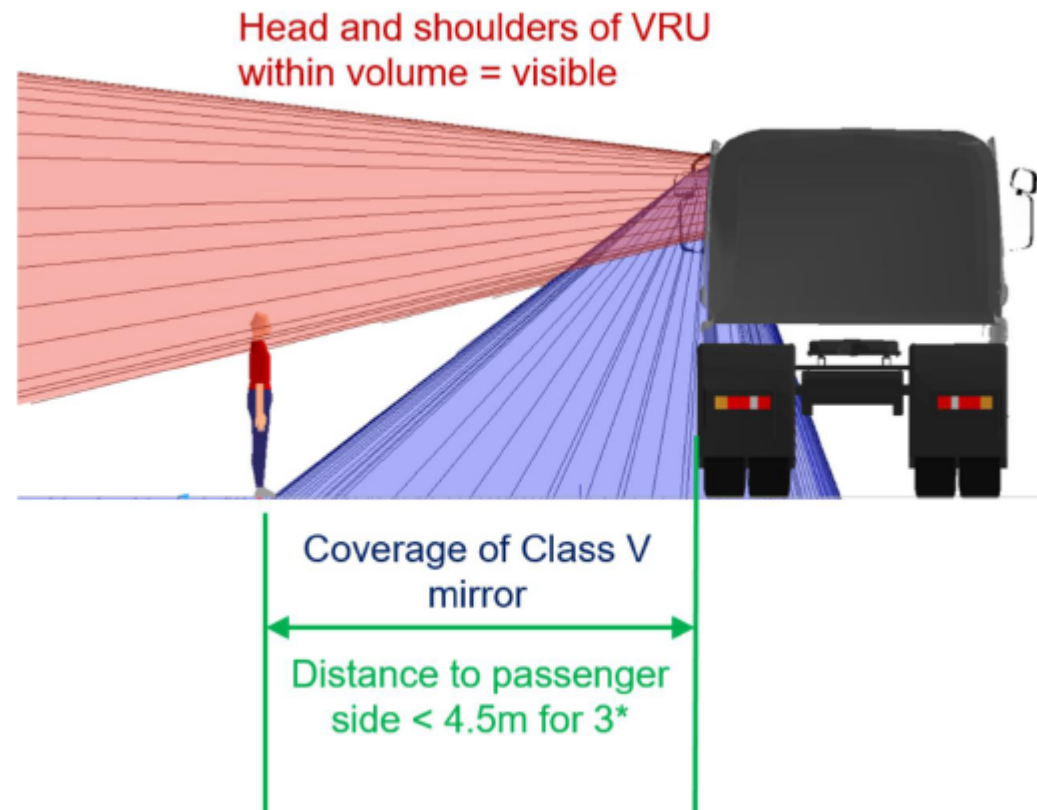

Example :Identification of boundaries

Unfortunately only 5 vehicles meet this test to the front

& Less than half of the sample meet this test to the passenger side

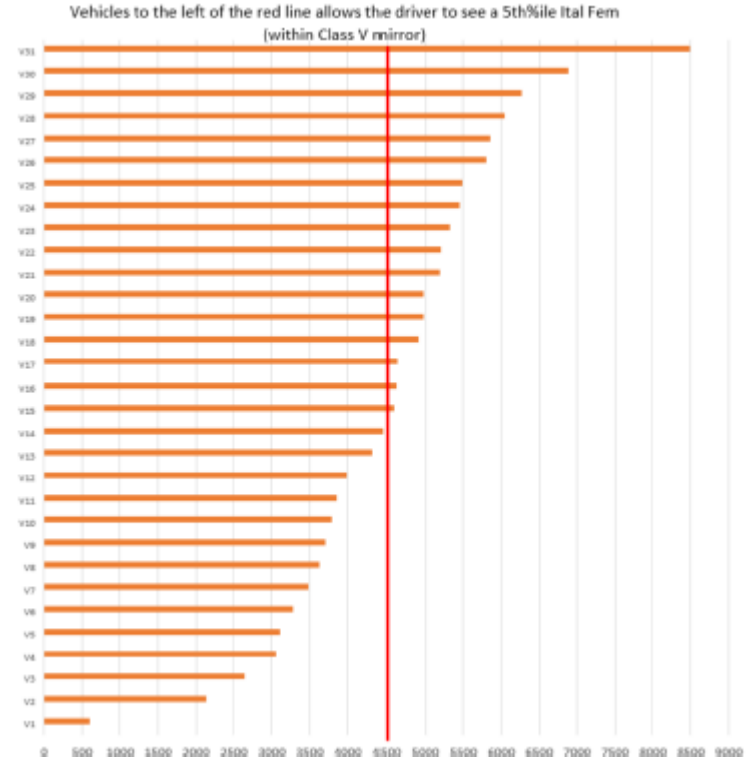
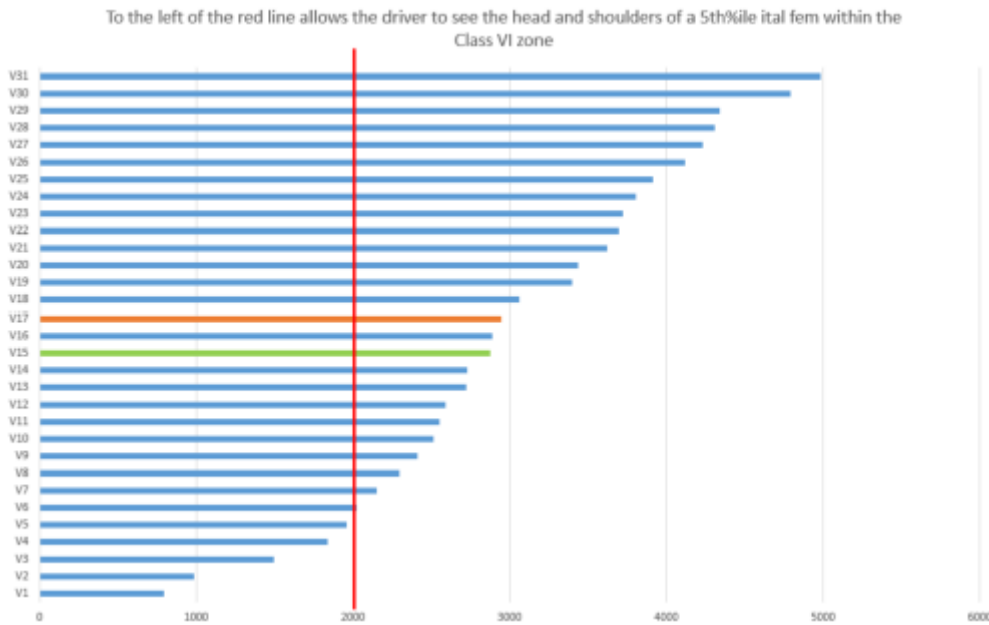

Performance to the front is poor

Example: setting of star boundaries

Candidate 1 volume trimmed & compared to the Summed VRU distance for all sides

- This proposal defines 7 of the examined sample as zero star
- 1 of the examined vehicles as 5 star
- More vehicles to be added

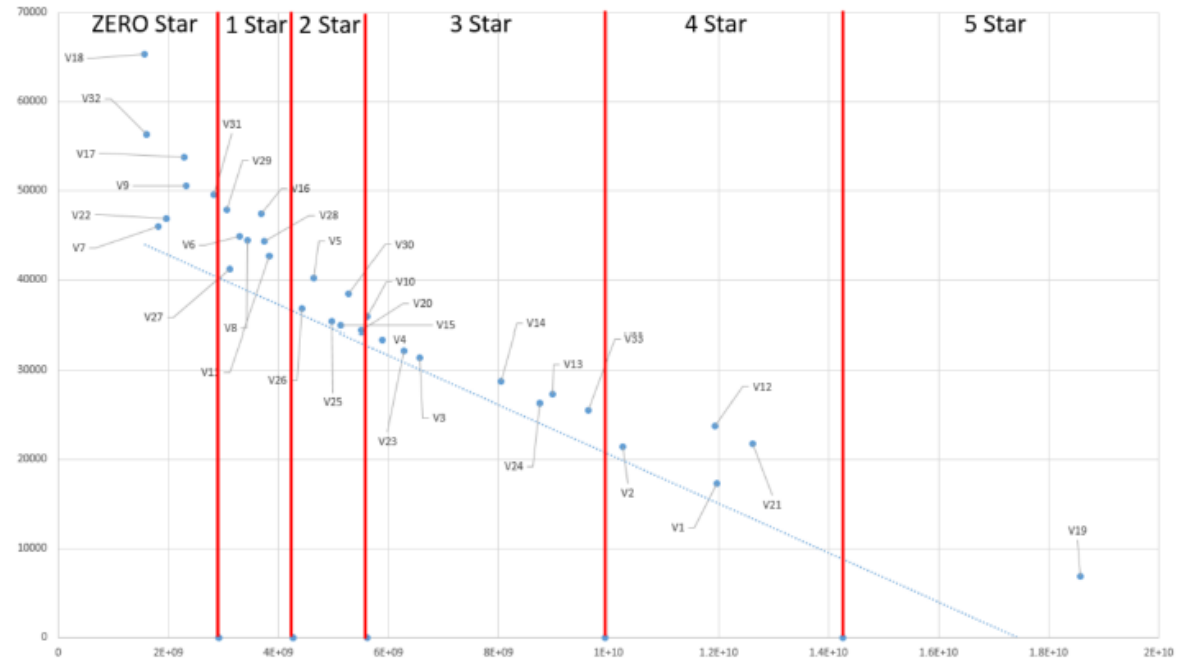

Summary

- Using volumes Trimmed to the size of mirror coverage zones as per UNECE reg 46 provided the clearest way to subdivide the volumetric results at this point
- Weighting by accident data and by height simply compressed the results for volume in a manner which reduced the ability of the DVS to differentiate between designs
- Feedback from the expert group held on 21 June suggested we should look at a smaller zone on the nearside – that analysis is taking place now
- VRU distances at which the head and shoulders of a 5thile Italian Female (therefore including all European adults above this) have been used so far to quality the volumetric performance - we have also invited suggestions for other
- The sample as a whole performed poorly tests to define the boundary of zero star
 - Test 1. Can a 5thile Italian female be seen (head and shoulders at least) when standing at the edge of the class V mirror zone (4.5m) to the passenger side of the cab?
 - Test 2. Can a 5thile Italian female be seen (head and shoulders at least) when standing at the edge of the class VI mirror zone (2m) to front of the cab?
- We would like the opinion of the manufacturers on this proposal and will consider alternatives where practical in the time period defined by TfL

Direct Vision Standard - next steps

- Work to date and full methodology was presented to vehicle manufacturers and 'Expert Group' on 21 June
 - Awaiting feedback
 - Further tests to determine and finalise DVS ratings with recommendation to TfL Project Board and City Hall
- Scoping on measurement, certification and labelling mechanism – sub working group end of July
- Look-up tables to be produced to enable ratings of different make/model/height configurations
 - N3 Euro VI – Summer 2017
 - Euro V (and IV) Autumn 2017
- Second round of consultation on the Mayor's proposals is due Autumn 2017

JULY 2017

Thank you

Hannah.White@tfl.gov.uk

