

Proposal is based on GRRF-85-02-Rev.

Proposals for Category C2 with Blind Spot Sensors

Proposal for the 03 series of amendments to UN Regulation No. 79

I. Proposal

Insert a new paragraph 2.4.16. and 2.4.17., to read:

"2.4.16. A "Lane Change Procedure (LCP)" in the case of ACSF of Category C starts when the direction indicator lamps are activated by a deliberate action of the driver and ends when the direction indicator lamps are deactivated. It comprises the following operations:

- (a) Activation of the direction indicator lamps by a deliberate action of the driver,
- (b) Lateral movement of the vehicle towards the lane boundary *
- (c) Lane change manoeuvre,
- (d) Resumption of the lane keeping function,
- (e) Deactivation of direction indicator lamps.

***: may be initiated by a second deliberate action of the driver**

2.4.17. A "Lane Change Manoeuvre (LCM)" is part of the lane change procedure and,

- (a) Starts when the outside edge of the tyre tread of the vehicle's front wheel closest to the lane markings touches the inside edge of the lane marking to which the vehicle is being manoeuvred,
- (b) Ends when the rear wheels of the vehicle have fully crossed the lane marking."

Renumber paragraph 5.1.10., as Paragraph 5.1.11

Insert a new paragraph 5.6.3., to read:

"(Reserved for ACSF of category B2)"

Insert a new paragraph 5.6.4., to read:

"5.6.4. Special Provisions for ACSF of Category C

Any ACSF system of Category C shall fulfil the following requirements.

5.6.4.1. General

5.6.4.1.1. A vehicle equipped with an ACSF of Category C shall also be equipped with an ACSF of Category B1 complying with the requirements of this Regulation.

5.6.4.1.2. When the ACSF of Category C is activated (stand by) the ACSF of Category B1 shall aim to center the vehicle in the lane.

This shall be demonstrated to the technical service during type approval.

- 5.6.4.2. Activation/deactivation of the ACSF of Category C system**
- 5.6.4.2.1.** The default status of the system shall be off at the initiation of each new engine start/run cycle.
- This requirement does not apply when a new engine start/run cycle is performed automatically, e.g. the operation of a stop/start system.
- 5.6.4.2.2.** The vehicle shall be equipped with a means for the driver to activate (standby mode) and deactivate (off mode) the system. The same means as for an ACSF of Category B1 may be used.
- 5.6.4.2.3.** The system shall only be activated (standby mode) after a deliberate action by the driver.
- Activation by the driver shall only be possible on roads where pedestrians and cyclists are prohibited and which, by design, are equipped with a physical separation that divides the traffic moving in opposite directions and which have at least two lanes in the direction the vehicles are driving. These conditions shall be ensured by the use of at least two independent means.
- In the case of a transition from a road type with a classification permitting an ACSF of Category C, to a type of road where an ACSF of Category C is not permitted, the system shall be deactivated automatically.
- 5.6.4.2.4.** It shall be possible to deactivate the system (off mode) at any time by a single action of the driver. Following this action, the system shall only be able to be reactivated (standby mode) by a deliberate action of the driver.
- 5.6.4.2.5.** Notwithstanding the requirements above it shall be possible to perform the corresponding tests in Annex 8 of this Regulation on a test track.
- 5.6.4.3. Overriding**
- A steering input by the driver shall override the steering action of the system. The steering control effort necessary to override the directional control provided by the system shall not exceed 50 N.
- The system may remain activated (standby mode) provided that priority is given to the driver during the overriding period.
- 5.6.4.4. Lateral acceleration**
- The lateral acceleration induced by the system during the lane change manoeuvre:
- (a) Shall not exceed 1 m/s² in addition to the lateral acceleration generated by the lane curvature, and
- (b) Shall not cause the total vehicle lateral acceleration to exceed the maximum values indicated in tables of paragraph 5.6.2.1.3.
- The moving average over half a second of the lateral jerk generated by the system shall not exceed 5 m/s³.
- 5.6.4.5. Human Machine Interface (HMI)**
- 5.6.4.5.1.** Unless otherwise specified, the optical signals identified in paragraph 5.6.4.5. shall be easily distinguishable from each other (e.g. different symbol, colour, blinking, text).
- 5.6.4.5.2.** When the system is in standby mode (i.e. ready to intervene), an optical signal shall be provided to the driver.

- 5.6.4.5.3. When the lane change procedure is ongoing an optical signal shall be provided to the driver.
- 5.6.4.5.4. When the lane change procedure is suppressed, in accordance with paragraph 5.6.4.6.8., the system shall clearly inform the driver about this system status by an optical warning signal and additionally by an acoustic or haptic warning signal. In case the suppression is initiated by the driver, an optical warning is sufficient.
- 5.6.4.5.5. A system failure shall be signalled immediately to the driver by an optical warning signal. However, when the system is manually deactivated by the driver, the indication of failure mode may be suppressed.
- If a system failure occurs during a lane change manoeuvre, the failure shall be signalled to the driver by an optical, and an acoustic or haptic warning.
- 5.6.4.5.6. The system shall provide a means of detecting that the driver is holding the steering control and shall warn the driver in accordance with the warning strategy below:
- If, after a period of no longer than 3 seconds after the initiation of the lane change procedure, the driver is not holding the steering control, an optical warning signal shall be provided. This signal shall be the same as the signal specified in paragraph 5.6.2.2.5. .
- The warning signal shall be active until the driver is holding the steering control, or until the system is deactivated, either manually or automatically.
- 5.6.4.6. Lane change procedure
- 5.6.4.6.1. The initiation of a lane change procedure of an ACSF of Category C shall only be possible if an ACSF of Category B1 is already active.
- 5.6.4.6.2. The lane change procedure requires, and shall start immediately after, a manual activation by the driver of the direction indicator to the intended side for the lane change.
- 5.6.4.6.3. When the lane change procedure starts, the ACSF of Category B1 shall be suspended, and the ACSF of Category C shall carry on the lane keeping function of ACSF of category B1, until the lane change manoeuvre starts.
- 5.6.4.6.4. The lateral movement of the vehicle towards the intended lane shall not start earlier than 1 s after the start of the lane change procedure. Additionally the lateral movement to approach the lane marking and the lateral movement necessary to complete the lane change manoeuvre, shall be completed as one continuous movement.
- The lane change manoeuvre shall not be initiated before a period of 3.0s and not later than 5.0 s after the deliberate action of the driver described in paragraph 5.6.4.6.2.. **Alternatively the lane change manoeuvre may be initiated by a second deliberate action of the driver performed not later than [10] seconds after the procedure start.**
- 5.6.4.6.5. The lane change manoeuvre shall be completed in less than:
- (a) 5 s for M₁, N₁ vehicle categories,
 - (b) 10 s for M₂, M₃, N₂, N₃ vehicle categories.
- 5.6.4.6.6. Once the lane change manoeuvre has completed, ACSF of Category B1 lane keeping function shall resume automatically.

- 5.6.4.6.7. The direction indicator shall remain active throughout the whole period of the lane change manoeuvre and shall be deactivated by the system no later than 0.5 seconds after the resumption of ACSF of Category B1 lane keeping function as described in paragraph 5.6.4.6.6.. **Automatic deactivation of the direction indicator is required only if the lane change manoeuvre is initiated automatically.**
- 5.6.4.6.8. Suppression of the lane change procedure
- 5.6.4.6.8.1. The lane change procedure shall be suppressed automatically by the system when at least one of the following situations occurs before the lane change manoeuvre has started:
- (a) The system detects a critical situation (as defined in para. 5.6.4.7),
 - (b) The system is overridden or switched off by the driver,
 - (c) The system reaches its boundaries (e.g. lane markings are no longer detected),
 - (d) The system has detected that the driver is not holding the steering control at the start of the lane change manoeuvre,
 - (e) The direction indicator lamps are manually deactivated by the driver,
 - (f) The lane change manoeuvre has not commenced within 5.0 s following the deliberate action of the driver described in para. 5.6.4.6.2., **or the second deliberate action is not performed by the driver latest [10] seconds after the procedure start, whichever is appropriate.**
 - (g) The lateral movement described in paragraph 5.6.4.6.4 is not continuous.
- 5.6.4.6.8.2. Manual deactivation of the lane change procedure, using the manual control of the direction indicator, shall be possible for the driver at any time.

5.6.4.7. Critical situation

5.6.4.7.1 Critical situation for systems with automatic initiation of the LCM (see. Par. 5.6.4.6.4):

A situation is deemed to be critical when, at the time a lane change manoeuvre starts, an approaching vehicle in the target lane would have to decelerate at a higher level than 3m/s^2 , 0.4 seconds after the lane change manoeuvre has started, to ensure the distance between the two vehicles is never less than that the ACSF vehicle travels in 1 second.

The resulting critical distance at the start of the lane change manoeuvre shall be calculated using the following formula:

$$S_{critical} = (v_{rear} - v_{ACSF}) * t_B + (v_{rear} - v_{ACSF})^2 / (2 * a) + v_{ACSF} * t_G$$

Where:

- v_{rear} = Actual speed of the approaching vehicle or 130 km/h whatever value is lower.
- v_{ACSF} = Actual speed of the ACSF vehicle
- a = 3 m/s^2 (Deceleration of the approaching vehicle)
- t_B = 0.4 s (Time after the start of the manoeuvre at which the deceleration of the approaching vehicle starts)

$t_G = 1s$ (Remaining gap of the vehicles after the deceleration of the approaching vehicle)

5.6.4.7.2 Critical situation for systems requiring a separate (second) deliberate action to initiate the LCM (see. Par. 5.6.4.6.4)

A situation is deemed to be critical when at the time the second deliberate action is performed, an approaching vehicle in the intended lane is located in the area defined in paragraph 5.6.4.8.2.2.

5.6.4.8. Minimum distance and minimum operation speed

5.6.4.8.1 Minimum distance and minimum operation speed for systems with automatic initiation of the LCM (see. Par. 5.6.4.6.4)

5.6.4.8.1.1. The ACSF of Category C shall be able to detect vehicles approaching from the rear in an adjacent lane up to a distance S_{rear} as specified below:

The minimum distance S_{rear} shall be declared by the vehicle manufacturer. The declared value shall not be less than 55 m.

The declared distance shall be tested according to the relevant test in Annex 8 using a two-wheeled motor vehicle of Category L3 as the approaching vehicle.

The minimum operation speed V_{smin} , down to which the ACSF of Category C is permitted to perform a lane change manoeuvre, shall be calculated with minimum distance S_{rear} using the following formula:

$$V_{Smin} = a * (t_B - t_G) + v_{app} - \sqrt{a^2 * (t_B - t_G)^2 - 2 * a * (v_{app} * t_G - S_{rear})}$$

Where:

$S_{rear} =$ Minimum distance declared by the manufacturer in [m]

$V_{app} = 36.1$ m/s (Speed of the approaching vehicle = 130 km/h)

$a = 3$ m/s² (Deceleration of the approaching vehicle)

$t_B = 0.4s$ (Time after the start of the manoeuvre at which the deceleration of the approaching vehicle starts)

$t_G = 1s$ (Remaining gap of the vehicles after the deceleration of the approaching vehicle)

$V_{smin} =$ in m/s Resulting minimum activation speed of the ACSF of Category C

If the vehicle is operated in a country with a general maximum speed limit below 130 km/h, this speed limit may be used as an alternative for V_{app} in the above formula to calculate the minimum operation speed V_{smin} . In this case the vehicle shall be equipped with a mean to detect the country of the operation and shall have information available on the general maximum speed limit of this country.

Notwithstanding the requirements above in this paragraph, the ACSF of Category C is permitted to perform a lane change manoeuvre at speeds lower than the calculated V_{smin} provided that the following conditions are met:

(a) The system has detected another vehicle in the adjacent lane into which the lane change is planned at a distance lower than S_{rear} and

(b) The situation is not deemed to be critical according to paragraph 5.6.4.7.1 (e.g. at low speed differences and $V_{app} < 130$ km/h).

(c) The declared value S_{rear} is greater than the calculated value $S_{critical}$ from paragraph 5.6.4.7.1.

5.6.4.8.1.2. The vehicle system detection area on ground level shall be at minimum as shown in the figure below.

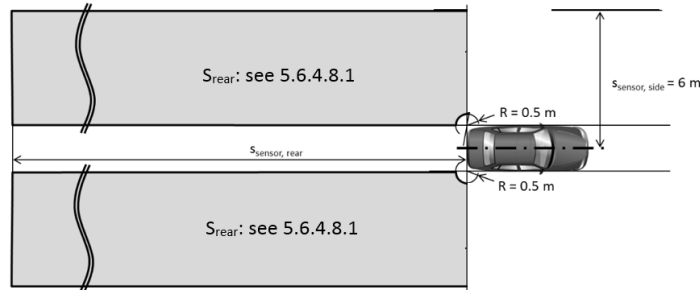

5.6.4.8.2 Minimum distance for systems requiring a separate (second) deliberate action to initiate the LCM (see. Par. 5.6.4.6.4)

5.6.4.8.2.1. The ACSF of Category C shall be able to detect vehicles approaching from the rear in an adjacent lane up to a distance S_{Rear} of 3m behind the vehicle.

5.6.4.8.2.2. The vehicle system detection area on ground level shall be at minimum as shown in the figure below.

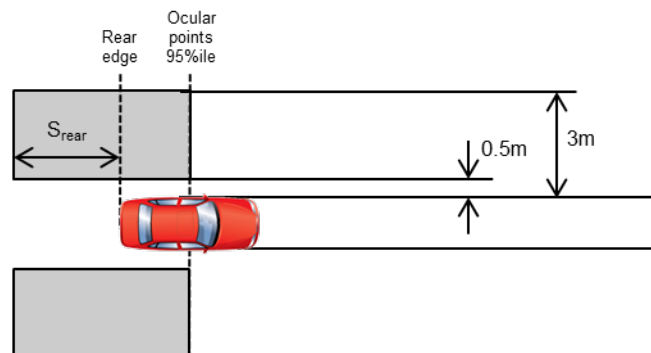

5.6.4.8.3. After each vehicle new engine start/run cycle (other than when performed automatically, e.g. the operation of a stop/start systems), the ACSF of Category C function shall be prevented from performing a lane change manoeuvre until the system has detected, at least once, a moving object at a distance greater than the minimum distance S_{rear} declared by the manufacturer in 5.6.4.8.1.1. or the value from paragraph 5.6.4.8.2.1 whatever is appropriate.

5.6.4.8.4. The ACSF of Category C shall be able to detect blindness of the sensor (e.g. due to accumulation of dirt, ice or snow). The ACSF of Category C shall be prevented, upon detection of blindness, from performing the lane change manoeuvre. The status of the system shall be signalled to the driver no later than on the initiation of the lane change manoeuvre. The same warning as the one specified in paragraph 5.6.4.5.5. (system failure warning) may be used.

5.6.4.9. System information data

- 5.6.4.9.1.** Following data shall be provided together with the documentation package required in Annex 6 of this regulation to the Technical Service at the time of type approval.
- 5.6.4.9.1.1.** The conditions under which the system can be activated and the boundaries for operation (boundary conditions). The vehicle manufacturer shall provide values for V_{smax} , V_{smin} and ay_{smax} for every speed range as mentioned in the table of paragraph 5.6.2.1.3. of this Regulation.
- 5.6.4.9.1.2.** Information about how the system detects that the driver is holding the steering control.
- 5.6.4.9.1.3.** The means to override and to suppress or cancel.
- 5.6.4.9.1.4.*** Information about how the failure warning signal status and the confirmation of the valid software version related ACSF performance can be checked via the use of an electronic communication interface.
- 5.6.4.9.1.5.*** Documentation about which system software version related ACSF performance is valid. This documentation shall be updated whenever a software version was amended.

* This paragraph shall be reviewed once the UNECE WP.29 IWG ITS/AD Task Force on Cyber Security and Over the air issues has finalized its work on measures for software identification and, if necessary, amended accordingly.

- 5.6.4.9.1.6.** Information on the sensor range over lifetime. The sensor range shall be specified such way that any influence on deterioration of the sensor shall not affect the fulfilment of paragraph 5.6.4.8.3. and 5.6.4.8.4. of this Regulation.
- 5.6.4.10.** The vehicle with ACSF of Category C shall be tested in accordance with relevant vehicle test(s) specified in Annex 8 of this Regulation. For driving situations not covered by the tests of Annex 8, the safe operation of the ACSF shall be demonstrated by the vehicle manufacturer on the base of Annex 6 of this Regulation."

Insert new paragraph 12.7., to read:

"[...]."

**TEST section still needs to be checked for necessary updates for C2
(Numbering references to be checked as well)**

Insert a new paragraph 3.5 in Annex 8, to read:

"3.5. Tests for ACSF of Category C Systems

If not specified otherwise all vehicle test speeds shall be based on $V_{app}=130$ km/h.

The vehicle manufacturer shall demonstrate to the satisfaction of the Technical Service that the requirements are fulfilled for the whole speed range. This may be achieved on the basis of appropriate documentation appended to the test report.

3.5.1. Lane change functional test

3.5.1.1. The test vehicle shall be driven in a lane of a straight test track, which has at least two lanes in the same direction of travel, with road markings on each side of the lanes. The vehicle speed shall be $(V_{min} + 10)$ km/h.

The ACSF of Category C shall be activated (standby mode) and another vehicle shall approach from the rear in order to enable the system as specified in paragraph 5.6.4.8.3.

The approaching vehicle shall then pass the vehicle under test entirely.

A lane change into the adjacent lane shall then be initiated by the driver.

The lateral acceleration and the lateral jerk shall be recorded during the test.

3.5.1.2. The requirements of the test are fulfilled if:

(a) The lateral movement towards the marking does not start earlier than 1 second after the lane change procedure was initiated,

(b) The lateral movement to approach the lane marking and the lateral movement necessary to complete the lane change manoeuvre are completed as one continuous movement,

(c) The recorded lateral acceleration does not exceed 1m/s^2 ,

(d) The moving average over half a second of the lateral jerk does not exceed 5 m/s^3 ,

(e) The measured time between the start of the lane change procedure and the start of the lane change manoeuvre is not less than 3.0s and not more than 5.0s,

(f) The system provides an information to the driver to indicate that the lane change procedure is on-going,

(g) The lane change manoeuvre is completed in less than 5s for M1, N1 vehicle categories and less than 10s for M2, M3, N2, N3 vehicle categories,

(e) ACSF of Category B1 automatically resumes after the lane change procedure is completed, and

(f) The direction indicator is deactivated not before the end of the lane change manoeuvre and no later than 0.5s after B1 has resumed.

- 3.5.1.3** The test according to 3.5.1.1 shall be repeated with a lane change in the opposite direction.
- 3.5.2** Minimum activation speed test V_{smin}
- 3.5.2.1** Minimum activation speed test V_{smin} based on $V_{app} = 130$ km/h.
- The test vehicle shall be driven with in a lane of a straight track which has at least two lanes in the same direction of travel and road markings each side of the lane.
- The vehicle speed shall be $(V_{smin} - 10\text{km/h})$.
- The ACSF of Category C shall be activated (standby mode) and another vehicle shall approach from the rear in order to enable the system as specified in paragraph 5.6.4.8.3..
- The approaching vehicle shall then pass the vehicle under test entirely
- A lane change procedure shall then be initiated by the driver.
- The requirements of the test are fulfilled if the lane change manoeuvre is not performed.
- 3.5.2.2** Minimum activation speed test V_{smin} based on country specific general maximum speed limit below 130 km/h.
- In case V_{smin} is calculated, based on a country specific general maximum speed limit instead of $V_{app} = 130$ km/h as specified in 5.6.4.8.1, the tests described in the subparagraphs below shall be performed. For this purpose it is allowed to simulate the country of operation in agreement between the vehicle manufacturer and the technical service.
- 3.5.2.2.1** The test vehicle shall be driven with in a lane of a straight track which has at least two lanes in the same direction of travel and road markings each side of the lane.
- The vehicle speed shall be $(V_{smin} - 10\text{km/h})$.
- The ACSF of Category C shall be activated (standby mode) and another vehicle shall approach from the rear in order to enable the system as specified in paragraph 5.6.4.8.3..
- The approaching vehicle shall then pass the vehicle under test entirely.
- A lane change procedure shall then be initiated by the driver.
- The requirements of the test are fulfilled if the lane change manoeuvre is not performed.
- 3.5.2.2.2** The test vehicle shall be driven with in a lane of a straight track which has at least two lanes in the same direction of travel and road markings each side of the lane.
- The vehicle speed shall be $(V_{smin} + 10\text{km/h})$.
- The ACSF of Category C shall be activated (standby mode) and another vehicle shall approach from the rear in order to enable the system as specified in paragraph 5.6.4.8.3..
- The approaching vehicle shall then pass the vehicle under test entirely.
- A lane change procedure shall then be initiated by the driver.
- The requirements of the test are fulfilled if the lane change manoeuvre is performed.

- 3.5.2.2.3** The manufacturer shall demonstrate to the satisfaction of the technical service that the vehicle is able to detect the country of operation and that the general maximum speed limit of this country is known.
- 3.5.3. Overriding test**
- 3.5.3.1.** The test vehicle shall be driven in a lane of a straight test track, which has at least two lanes in the same direction of travel, with road markings on each side of the lanes.
- The vehicle speed shall be ($V_{\text{min}} + 10\text{km/h}$).
- The ACSF of Category C shall be activated (standby mode) and another vehicle shall approach from the rear in order to enable the system as specified in paragraph 5.6.4.8.3..
- The approaching vehicle shall then pass the vehicle under test entirely.
- A lane change into the adjacent lane shall then be initiated by the driver.
- The steering control shall be firmly controlled by the driver to maintain the vehicle in the straight direction.
- The force applied by the driver on the steering control during the overriding manoeuvre shall be recorded.
- 3.5.3.2.** The test requirements are fulfilled if the measured overriding force does not exceed 50 N, as specified in 5.6.4.3.
- 3.5.3.3.** The test according to 3.5.3.1 shall be repeated with a lane change in the opposite direction.
- 3.5.4. Lane change procedure suppression test**
- 3.5.4.1.** The test vehicle shall be driven in a lane of a straight test track, which has at least two lanes in the same direction of travel, with road markings on each side of the lanes.
- The vehicle speed shall be ($V_{\text{min}} + 10\text{km/h}$).
- The ACSF of Category C shall be activated (standby mode) and another vehicle shall approach from the rear in order to enable the system as specified in paragraph 5.6.4.8.3..
- The approaching vehicle shall then pass the vehicle under test entirely.
- A lane change procedure shall then be initiated by the driver.
- The test shall be repeated for each of the following conditions, which shall occur before the lane change manoeuvre has started:
- (a) The system is overridden by the driver;
 - (b) The system is switched off by the driver;
 - (c) The vehicle speed is reduced to ($V_{\text{min}} - 10\text{ km/h}$);
 - (d) The driver has removed his hands from the steering control and the hands-off warning has been initiated;
 - (e) The direction indicator lamps are manually deactivated by the driver;
 - (f) The lane change manoeuvre has not commenced within 5.0 s following the initiation of the lane change procedure. (e.g. another vehicle is driving in the adjacent lane in a critical situation as described in 5.6.4.7.).

- 3.5.4.2.** The requirements of the test are fulfilled if the lane change procedure is suppressed, for each of the test cases above.
- 3.5.5.** Sensor performance test
- 3.5.5.1** The test vehicle shall be driven in a lane of a straight test track, which has at least two lanes in the same direction of travel, with road markings on each side of the lanes.
- The vehicle speed shall be ($V_{\text{min}} + 10\text{km/h}$).
- The ACSF of Category C shall be activated (standby mode).
- Another vehicle shall approach from the rear on the adjacent lane, with a speed of 120km/h.
- The approaching vehicle shall be a type approved high volume series production L3 motorcycle with an engine capacity not exceeding 600 ccm without front fairing nor windscreen and shall aim to drive in the middle of the lane.
- The distance between the rear end of the test vehicle and the front end of the approaching vehicle shall be measured (e.g. with a differential GPS), and the value when the system detects the approaching vehicle shall be recorded.
- 3.5.5.2.** The requirements of the test are fulfilled if the system detects the approaching vehicle latest at the distance declared by the vehicle manufacturer (S_{rear}), as specified in 5.6.4.8.1.
- 3.5.6** Sensor blindness test
- 3.5.6.1.** The test vehicle shall be driven in a lane of a straight test track, which has at least two lanes in the same direction of travel, with road markings on each side of the lanes.
- The vehicle speed shall be ($V_{\text{min}} + 10\text{km/h}$).
- The ACSF of Category C shall be activated (standby mode) and another vehicle shall approach from the rear in order to enable the system as specified in paragraph 5.6.4.8.3.
- The approaching vehicle shall then pass the vehicle under test entirely.
- The rear sensor(s) shall be made blind, with means agreed between the vehicle manufacturer and the Technical Service, which shall be recorded in the test report. This operation may be carried out at standstill, provided no new engine start /run cycle is performed.
- The vehicle shall be driven to a speed of ($V_{\text{min}} + 10\text{km/h}$), and a lane change procedure shall be initiated by the driver.
- 3.5.6.2.** The requirements of the test are fulfilled if the system:
- (a) detects the sensor blindness,
 - (b) provides a warning to the driver as defined in 5.6.4.8.4. and,
 - (c) is prevented from performing the lane change manoeuvre.
- In addition to the above mentioned test, the manufacturer shall demonstrate to the satisfaction of the Technical Service that the requirements defined in paragraph 5.6.4.8.4. are also fulfilled under different driving scenarios. This may be achieved on the basis of appropriate documentation appended to the test report.
- 3.5.7.** Engine start/run cycle test
- The test is divided in 3 consecutive phases as specified below.

The vehicle speed shall be ($V_{\text{min}} + 10\text{km/h}$).

3.5.7.1. Phase 1 – Default-off test

3.5.7.1.1. Following a new engine start /run cycle performed by the driver, the test vehicle shall be driven in a lane of a straight test track, which has at least two lanes in the same direction of travel, with road markings on each side of the lanes.

The ACSF of Category C shall not be activated (off mode) [and another vehicle shall approach from the rear and the approaching vehicle shall pass the vehicle entirely].

The direction indicator used to initiate a lane change procedure shall be activated by the driver for a period greater than 5 seconds.3.5.7.1.2. The requirements of the test phase 1 are fulfilled if the lane change manoeuvre is not initiated.

3.5.7.2. Phase 2

The objective of the test is to check that the lane change manoeuvre is prevented if the system has not detected any moving object at a distance equal or greater than the distance S_{rear} (as specified in paragraph 5.6.4.8.3.).

3.5.7.2.1. Following a new engine start /run cycle performed by the driver, the test vehicle shall be driven in a lane of a straight test track, which has at least two lanes in the same direction of travel, with road markings on each side of the lanes.

The ACSF C1 shall be manually activated (standby mode).

A lane change procedure shall then be initiated by the driver.

3.5.7.2.2. The requirements of the test phase 2 are fulfilled if the lane change manoeuvre has not started (as the pre-condition specified in 5.6.4.8.3. is not fulfilled).

3.5.7.3. Phase 3 – Lane change enabling conditions test

The objective of the test is to check that the lane change manoeuvre is only possible once the system has detected a moving object at a distance equal or greater than the distance S_{rear} (as specified in paragraph 5.6.4.8.3.).

3.5.7.3.1. Following the completion of the test phase 2, another vehicle shall approach from the rear on the adjacent lane in order to enable the system as specified in paragraph 5.6.4.8.3.

The approaching vehicle shall be a type approved high volume series production vehicle.

The distance between the rear end of the test vehicle and the front end of the approaching vehicle shall be measured (e.g. with a differential GPS), and the value when the system detects the approaching vehicle be recorded.

After the rear coming vehicle has entirely passed the vehicle under test, a lane change procedure shall be initiated by the driver.

3.5.7.3.2. The requirements of the test phase 3 are fulfilled if

(a) the lane change manoeuvre is executed,

(b) the approaching vehicle is detected latest at the distance declared by the vehicle manufacturer (S_{rear})."