

CLEPA Input on Flexible Exhaust System Technologies

Flexible exhaust system technologies

Rationale

Rationale:

„Flexible“ exhaust systems are a general concern by regulators

• **Conventional exhaust systems** are already flexible in terms of their response over frequency / engine rpm

• **Exhaust systems with passive valves** driven by exhaust flow. Customer cannot select/change sound performance.

• **Exhaust systems with electronically actuated systems**
Customer can select pre-defined and homologated operation modes

• **Replacing exhaust systems with electronically actuated systems**
Customer can control and may alter sound emission of the originally equipped & homologated exhaust system.

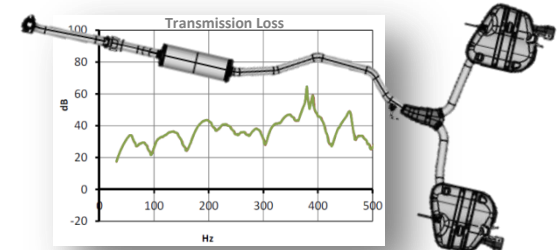

Source: Faurecia, Innovation selling toolkit presentations for external communication.

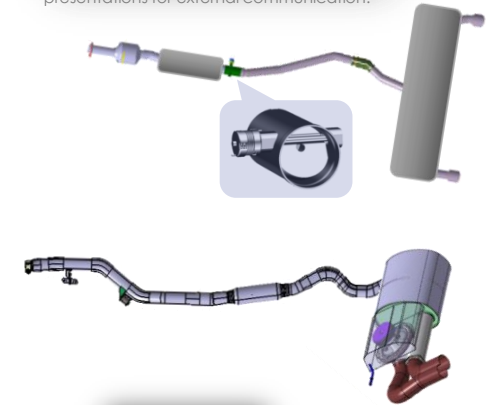

Source: <https://www.maxhaust.com/>

Flexible exhaust system technologies

Passive valves

Passive (self-actuated) valves are **opened by gas flow** against the spring force

- Valve closed at low flow rates
 - > high restriction reducing noise emission at idle and cruising
- Valve opens at high flow rates
 - > low restriction leading to a reduced backpressure (improved fuel economy)

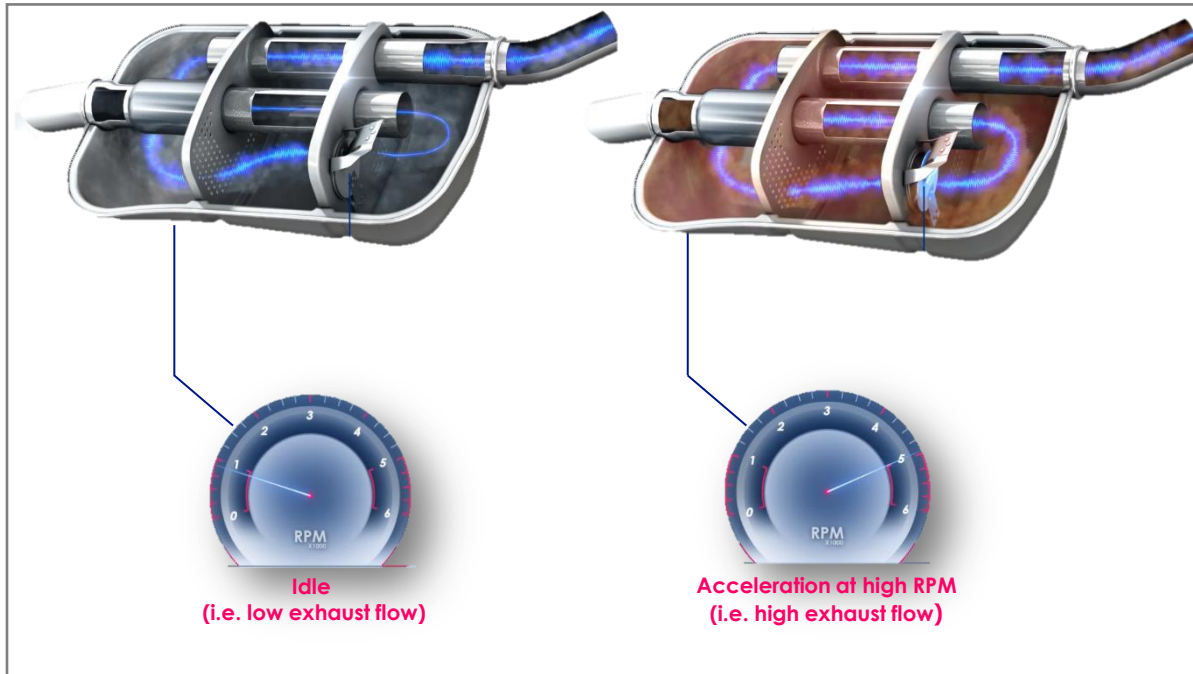

Source: Faurecia, Innovation selling toolkit presentations for external communication.

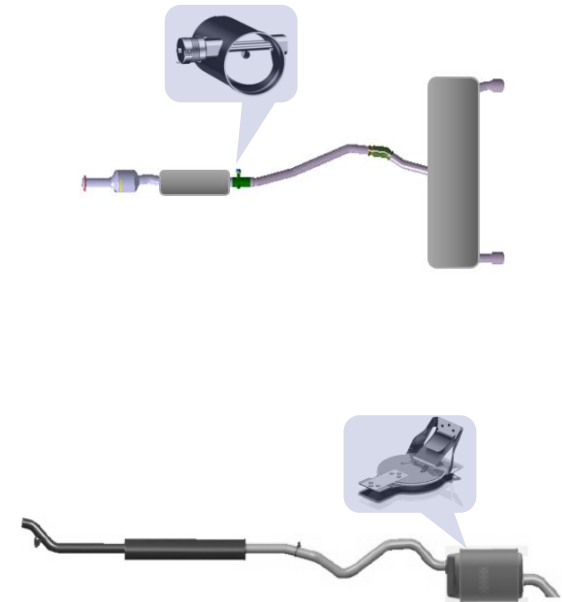

Flexible exhaust system technologies

Actuated valves

Electronically actuated valves are **operated in a similar strategy (pre-defined and homologated)**

- Valve closed at low flow rates / special vehicle conditions
 - > high restriction reducing noise emission at idle, cruising / cylinder deactivation
- Valve opens at high flow rates
 - > low restriction leading to a reduced backpressure (improved fuel economy)

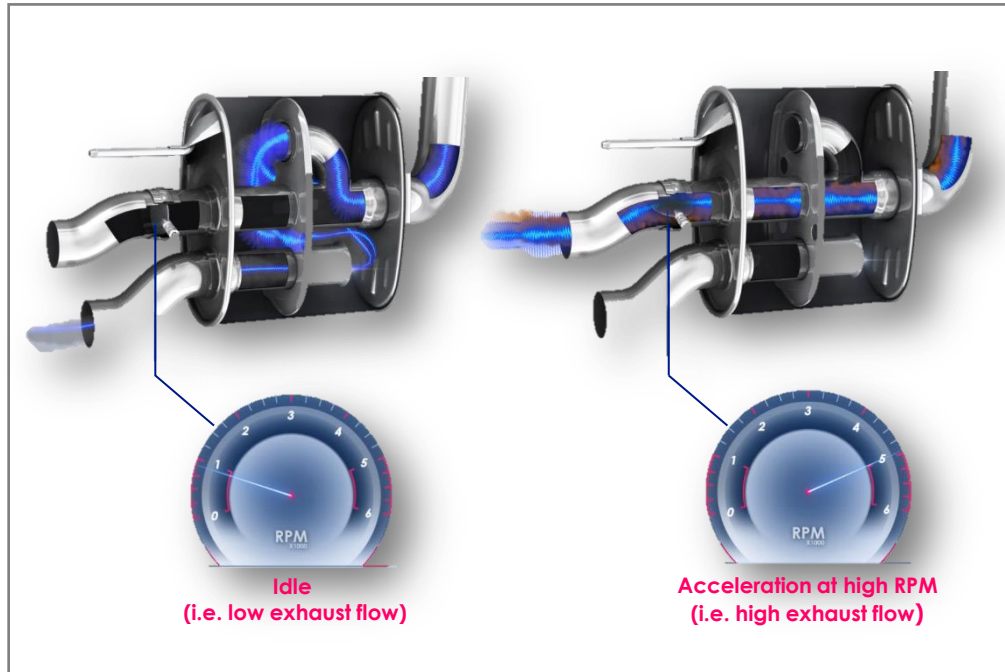

Source: Faurecia, Innovation selling toolkit presentations for external communication.

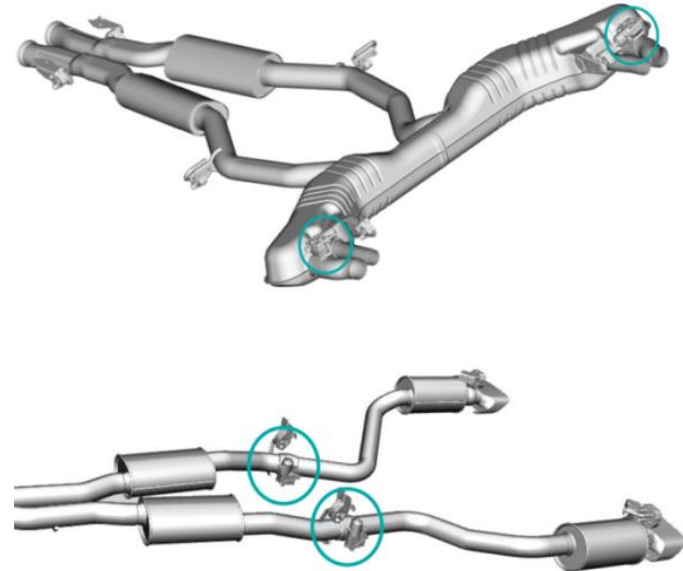

Flexible exhaust system technologies

Active noise cancellation & sound generation

Exhaust Dynamic Sound Generation

Adding defined sound/ frequencies to existing frequency content

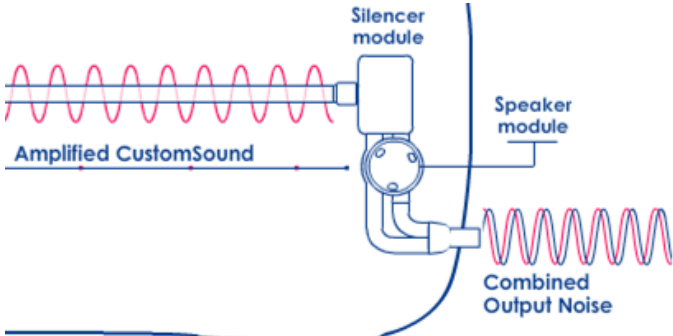

Exhaust Dynamic Noise Cancellation

Reducing existing frequency content

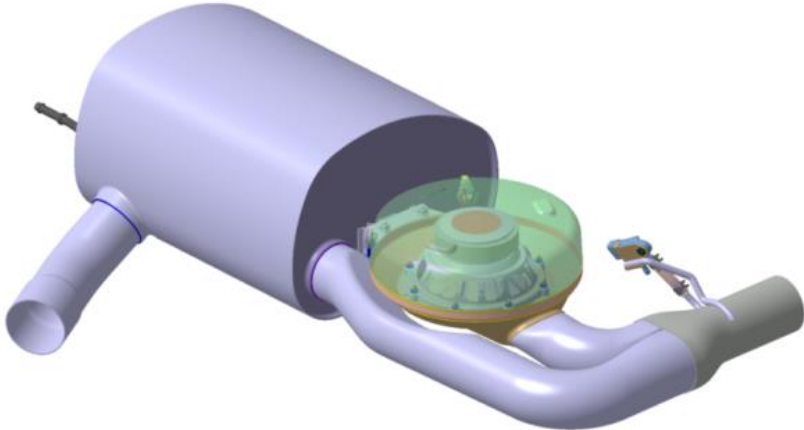
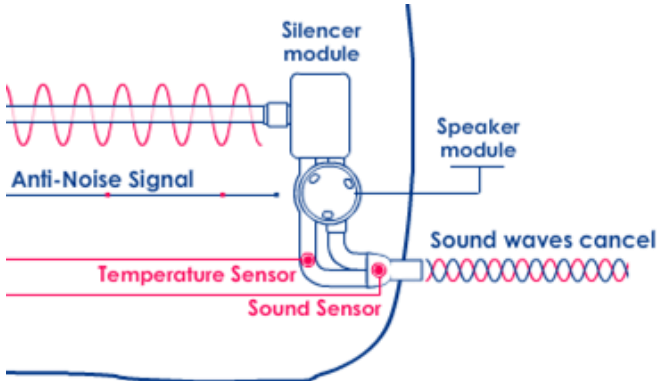

Source: Faurecia, Innovation selling toolkit presentations for external communication.

Flexible exhaust system technologies

Active Sound Generation (ESDG) application example

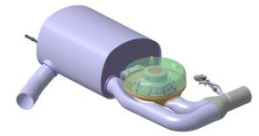

Case study with $PMR < 120 \text{ kW/t}$ vehicle shows that...

- ❑ ...an ESDG system enhances the sportiness of the sound emitted by the vehicle
- ❑ ...while a proper sound box application does not significantly increase the emitted noise (Annex 3) nor does it affect the linearity of noise emission (Annex 7).

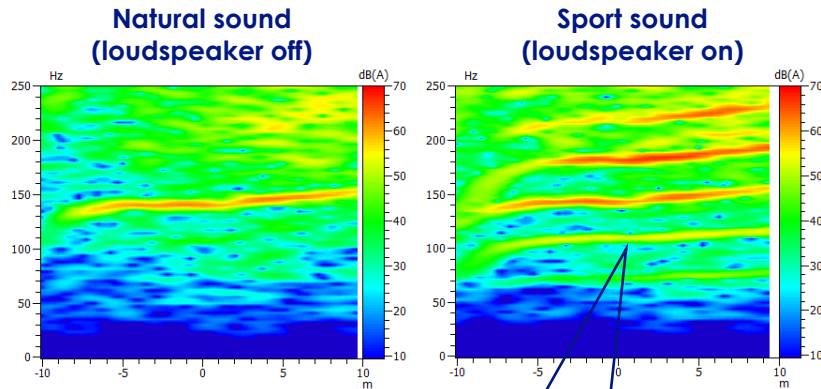

Continuous addition of engine order sound

Test according to Annex 3 of R51.03

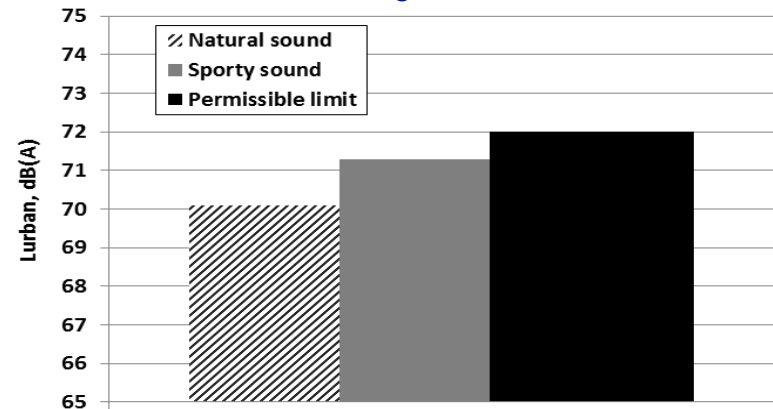

Source: Tobias Schindele, "Vehicle Noise Emission Legislation - Opportunity for innovative exhaust system solutions", Inter Noise 2017, Hongkong

Flexible exhaust system technologies

Active Noise Cancellation (EDNC) application example

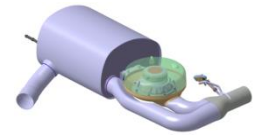

Case study with $PMR < 120 \text{ kW/t}$ vehicle shows that...

- ...great potential of active cancellation to reduce vehicle noise emission and hence pass-by noise levels

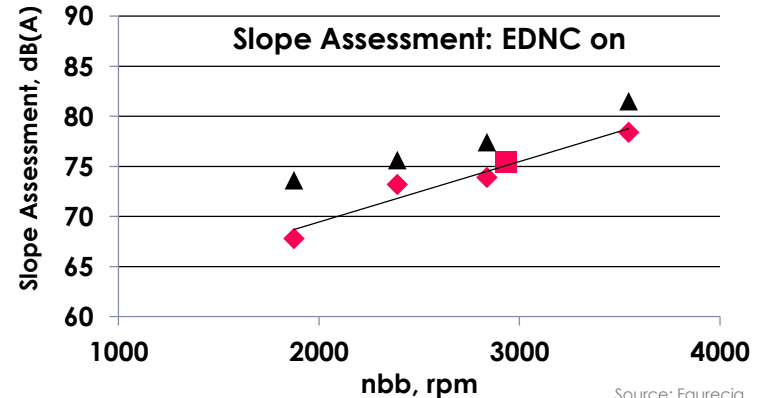
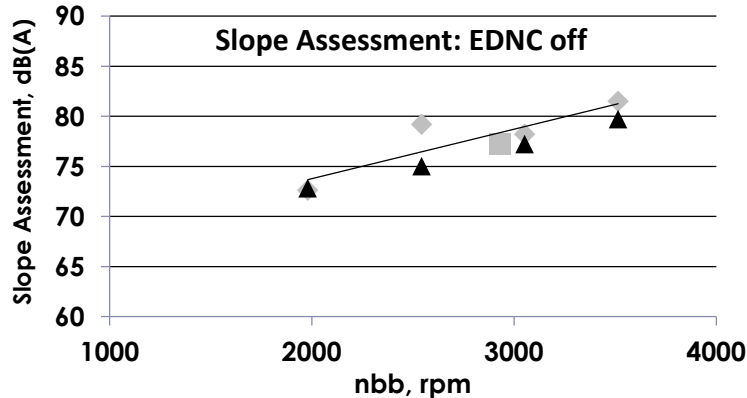
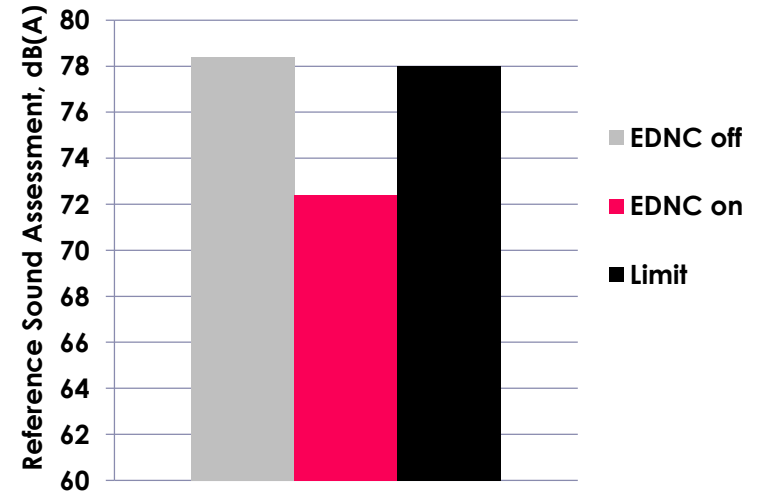
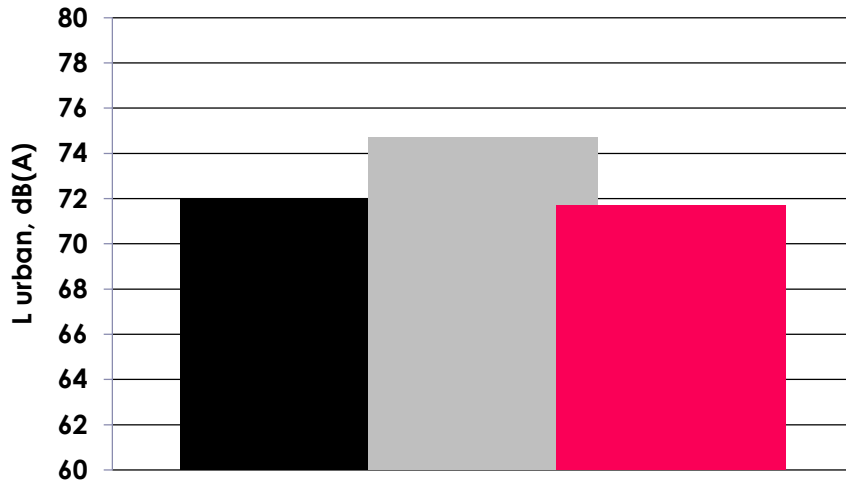

Source: Faurecia

Flexible exhaust system technologies

Conclusion

- ❑ **There are different levels of flexibility with regards to exhaust system technologies while this presentation focuses on original equipment exhaust systems with passive or active valves as well as active sound box systems.**

- ❑ **Flexible exhaust system technologies, such as active sound box systems or valves with pre-defined and homologated operation modes, are enabling technologies to reduce the overall vehicle noise emission and ensure compliance for the upcoming pass-by noise limit stages.**

**Thank you for your
attention.**

Questions?