

Flex PLI GTR

User Manual

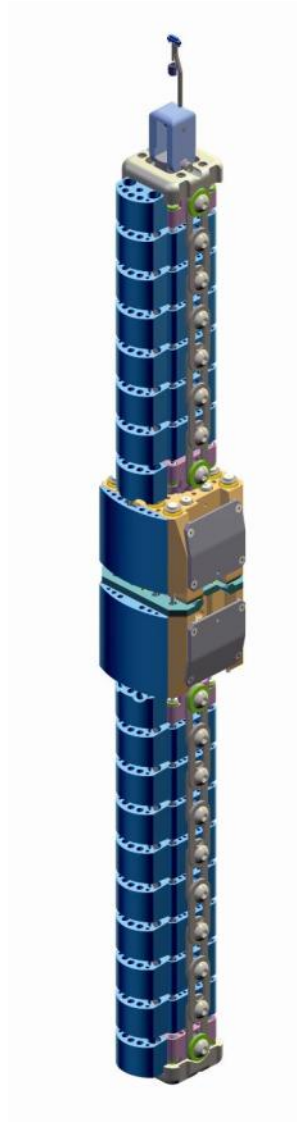



For information on Humanetics products, please visit our web site at www.humaneticsatd.com or contact:

Humanetics Innovative Solutions
47460 Galleon Drive
Plymouth, MI 48170, USA
Telephone: (+1) 734-451-7878
Fax: (+1) 734-451-9549

No part of this publication may be reproduced, stored in a retrieval system or transmitted in any form or by any means, electronic, photocopying, recording, mechanical or otherwise, without the express written consent of Humanetics Innovative Solutions.

Copyright © 2012 Humanetics Innovative Solutions. All rights reserved.

The information in this manual is furnished for informational use only, and is subject to change without notice. Humanetics Innovative Solutions assumes no responsibility or liability for any errors or inaccuracies that may appear in this manual.

Table of Contents

Section 1.	Introduction.....	9
1.1	Overview.....	9
1.2	Tools Required.....	11
Section 2.	Instrumentation	14
2.1	Standard 12 Channel instrumentation	14
2.2	Optional instrumentation.....	14
2.3	ISO MME Codes.....	20
2.3.1	Co-ordinate System.....	23
2.3.2	Signal Polarity, Sensor function check	24
2.3.3	Filter Class	24
2.4	Data Acquisition Options.....	25
2.5	Off Board DAS	25
2.6	Messring M=BUS On Board Data Acquisition	27
2.6.1	M=BUS description	27
2.6.2	24 Channel M=BUS.....	29
2.7	DTS Onboard SLICE Nano DAS	31
2.7.1	SLICE 24 Channel Option	35
2.7.2	Electrical Interference	35
2.8	DTI Hentschel Onboard DAS	36
2.8.1	DTI Description	36
2.9	KT MicroDAU Onboard DAS.....	38
2.9.1	MicroDAU Description.....	38
Section 3.	Assembly and Disassembly	41
3.1	Femur Exploded View	43
3.1.1.	Femur (Upper Leg) Assembly	45
3.1.2.	Femur assembly after static certification	49
3.1.3.	Femur Disassembly.....	49
3.2	Knee Exploded View	50
3.2.1.	Knee Assembly	51

3.2.2.	Assembly After Certification	54
3.2.3.	Knee Disassembly	54
3.3	Tibia Exploded View	56
3.3.1.	Tibia Assembly	58
3.3.2.	After Calibration:	61
3.3.3.	Tibia Disassembly	61
3.3.4.	Leg Assembly	61
3.3.5.	Fitting flesh	62
3.3.6.	Leg Disassembly	64
Section 4.	Maintenance	65
4.1	Introduction	65
4.2	General External Damage inspection	65
4.3	Support Roller	65
4.4	Red Neoprene Suit Covers	65
4.5	Protective Plastic End Covers (Part 133-5516).....	65
4.6	Tibia and Femur	66
4.6.1.	Assembly Segment Play.....	66
4.6.2.	Buffers between segments	66
4.6.3.	Shoulder Bolt and Segment Screw Tightness Check.....	66
4.7	Knee	66
4.7.1.	Knee Meniscus	66
4.7.2.	Knee spring cables and bone stopper cables.....	66
4.8	Sensor and Electrical Maintenance	67
4.8.1.	General Electrical Maintenance	67
4.8.2.	Bone Maintenance.....	67
4.8.3.	String Potentiometer Maintenance.....	67
Section 5.	Weight Specification.....	68
Section 6.	Calibration and certification testing.....	69
6.1	Calibration and Certification Overview	69
6.2	Femur and Tibia Bone Assembly Certification	70
6.2.1	Introduction.....	70

6.2.2 Femur and Tibia assembly Certification..... 70

6.3 Knee Certification..... 75

Section 7. Pendulum Dynamic Certification..... 77

7.1 Introduction..... 77

7.2 Pendulum Rig Assembly Instruction 78

7.3 Leg Preparation for Pendulum Dynamic Calibration 81

7.4 Pendulum Rig Preparation 83

7.5 Running a test..... 85

7.6 Data Processing..... 85

Section 8. Dynamic Inverse Certification Test 87

8.1 Introduction..... 87

8.2 Inverse Test Description 87

8.3 Preparation of the Inverse Test set up..... 88

8.4 Leg Preparation of the leg for Dynamic Inverse Test..... 89

8.5 Running a Dynamic Inverse Test..... 90

8.6 Data Processing..... 91

Section 9. Vehicle Test 92

9.1 Introduction..... 92

9.2 Leg Loading limits in free flight..... 92

9.3 WARNING! VIOLENT REBOUND!..... 92

9.4 Catch Rope..... 92

9.5 Impactor Pusher Plate 93

Table of Figures

Figure 1 .	T-Handle Wrenches.....	11
Figure 2 .	Hex Wrenches	12
Figure 3 .	Ratchet offset wrench with hex bits kit	12
Figure 4 .	Leg wire setting tool 133-5112.....	13
Figure 5 .	Knee spacer tool 133-5113.....	13
Figure 6 .	Optional Instrumentation for Femur.....	15
Figure 7 .	Detail A, Exploded View, upper and lower knee.....	16
Figure 8 .	Wire routing for Detail A optional sensors	16
Figure 9 .	Wire routing out of segment for optional sensors Detail A in upper knee	17
Figure 10 .	Similar arrangement to Detail A, but with 2 uniax Kyowa accels. Assembly 133-7600	17
Figure 11 .	Sensor IES 3103 ARS triax for Knee upper and lower used with M=BUS, (mount 133-7522)	18
Figure 12 .	Kyowa accel 3 axis option for leg top and bottom locations, (mount 133-7530).....	18
Figure 13 .	Optional Instrumentation, for Tibia	19
Figure 14 .	Leg Local Sign Convention.....	23
Figure 15 .	Leg manipulations for positive output.....	24
Figure 16 .	Clamping Arrangement and Position for Off board Wires	25
Figure 17 .	Off Board wiring left hand side of impact face.....	26
Figure 18 .	Off Board wiring right hand side of impact face.....	26
Figure 19 .	Wiring Diagram for 12 channel M=BUS.....	27
Figure 20 .	M=BUS arrangement in knee 12 channels LH side to impact direction	28
Figure 21 .	M=BUS arrangement 12 channels RH side of impact direction	28
Figure 22 .	Clamping of M=BUS Disconnect Connector	28
Figure 23 .	M=BUS Terminator housing installation in upper knee	29
Figure 24 .	Fixing M=BUS Wire to Launcher	29
Figure 25 .	Right hand side of knee M=BUS 24 channels, sensors not connected	30
Figure 26 .	Top right hand side of knee M=BUS 24 channels, sensors connected.....	30
Figure 27 .	Bottom right hand side of knee M=BUS 24 channels, sensors connected	30
Figure 28 .	Top left hand side of knee Messring 24 channels sensors connected.....	31
Figure 29 .	Bottom left hand side of knee M=BUS 24 channels, sensors connected.....	31
Figure 30 .	Wiring diagram for 12 channel SLICE	32
Figure 31 .	Typical 12 channel Slice wiring to knee.....	32
Figure 32 .	SLICE disconnect connector	33
Figure 33 .	LH of leg with knee covers fitted 12 channels. Leg wires are not shown secured.....	33
Figure 34 .	Right hand side of knee 12 channels showing connectors	34

Figure 35 .	Leg with disconnect wire, TDAS interface and power supply.....	34
Figure 36 .	Optional SLICE unit 24 channel option (right side).....	35
Figure 37 .	Left side wiring example of 24 channel SLICE	35
Figure 38 .	DTI DAS left hand side of knee showing Di Mod hubs.....	36
Figure 39 .	DTI DAS right hand side of knee showing crash recorder on the left and DiMod hub on the right.....	37
Figure 40 .	DTI DAS General Overview.....	37
Figure 41 .	Exploded view of knee showing Micro Dau integration	38
Figure 42 .	Showing drawing of Micro Dau part numbers.....	39
Figure 43 .	Right hand side of impact face, lower covers removed.....	39
Figure 44 .	Left hand side of impact face, covers fitted	40
Figure 45 .	Schematic layout of 12 channel Micro Dau	40
Figure 46 .	Leg assembly, Exploded View.....	41
Figure 47 .	Femur Assembly, Exploded View	43
Figure 48 .	133-8129 base with 133-5514 segment and bone clamps inside	46
Figure 49 .	133-8129 base with 133-5514 segment, bone clamps and bone assembly	47
Figure 50 .	Fitting and tightening first blue segment.....	47
Figure 51 .	Fitting thin bone spacer with captive shim	48
Figure 52 .	Bone exit cable restraint use cable ties (ties not shown trimmed or tightened)	49
Figure 53 .	Knee Assembly, Exploded View	50
Figure 54 .	Meniscus string pot assembly wire feed.....	52
Figure 55 .	Meniscus with all string pots assembled. String pots identified.....	52
Figure 56 .	Meniscus wire clamp	53
Figure 57 .	Attachment plate, crimp wires in tension ready for knee femur block assembly.....	54
Figure 58 .	Cross wire feed through on knee.....	54
Figure 59 .	Tibia Assembly, Exploded View.....	56
Figure 60 .	Typical shim arrangement with .05 shim inside captive shim.....	59
Figure 61 .	Assembly of last two segments on tibia.....	60
Figure 62 .	Fitting last two segments to tibia, applying force using M10 bolts.....	60
Figure 63 .	Screws to be tightened to 8 Nm non impact side	62
Figure 64 .	Assembly of first flesh layer	62
Figure 65 .	Zipper locations alternating on the sides (schematic cross section)	63
Figure 66 .	Assembly of flesh second layer	63
Figure 67 .	Rubber flesh assembly Velcro positions.....	64
Figure 68 .	Rubber flesh tied on with Velcro	64
Figure 69 .	Leg with outer cover fitted.....	64
Figure 70 .	String potentiometer pull wire length ± 1 mm	67
Figure 71 .	Example of fixing Teflon sheet to base plate.....	70

Figure 72 .	Bone and knee fixture 133-8120 for static assembly bending test femur shown	71
Figure 73 .	Static certification fixture 133-8120 showing knee	72
Figure 74 .	Bone Assembly Fixture (femur shown under bending).....	73
Figure 75 .	Femur assembly certification corridor moment vs. deflection showing typical results	74
Figure 76 .	Tibia assembly certification corridor moment vs. deflection showing a typical results.....	74
Figure 77 .	Knee Certification Fixture	75
Figure 78 .	Figure MCL sensor elongation Upper and lower corridor.....	76
Figure 79 .	Figure ACL and PCL upper and lower corridors.....	76
Figure 80 .	Diagram of Dynamic Pendulum Fixture	77
Figure 81 .	Exploded view Dynamic Rig part nr 133-8400	79
Figure 82 .	Check screws with 8 Nm torque	81
Figure 83 .	Stop cable clearance adjustment using setting tool	82
Figure 84 .	Recommended method to align knee to remove any twist and shear.....	82
Figure 85 .	Attaching Pendulum Ballast Weight	83
Figure 86 .	Attaching Pendulum Rig Pivot hinge	83
Figure 87 .	Checking the Impact Block position adjustment	84
Figure 88 .	Examples of release latches.....	84
Figure 89 .	Diagram of Dynamic Inverse Certification Test set up	88
Figure 90 .	Paper cloth wrapping of honeycomb	89
Figure 91 .	Launch guide with 15° tilt toward guided impactor	90
Figure 92 .	Optional catch rope bracket 133-5034	93
Figure 93 .	Impactor guide width setting 113mm.....	93
Figure 94 .	Humanetics Launch plate Part Nr 133-8200 (Aluminum and Carbon Fiber).....	94

Table List

Table 1.	Contents of the tool kit provided with the leg on delivery	13
Table 2.	12 Channel Instrumentation.....	14
Table 3.	Example of Optional Instrumentation Parts List	19
Table 4.	ISO MME Sensor Code table	22
Table 5.	Wire label codes for all sensors.....	23
Table 6.	Flex PLI Parts List.....	42
Table 7.	Femur Assembly, Parts List.....	44
Table 8.	Knee Assembly, Parts List.....	51
Table 9.	Tibia Assembly, Parts List	57
Table 10.	Flex PLI GTR Mass	68
Table 11.	Sensor Mass Breakdown.....	68
Table 12.	FLEX-PLI-GTR certification steps.....	69
Table 13.	Parts List for static fixture 133-8120	72
Table 14.	Pendulum Dynamic Rig Part List.....	80
Table 15.	Pendulum test corridors	86
Table 16.	Inverse test corridors	91

Section 1. Introduction

1.1 Overview

Pedestrian Lower Legform Impactors are used to evaluate pedestrian protection afforded by passenger vehicles in case of vehicle collision with a pedestrian. The current EEVC WG17 Pedestrian lower legform impactor is known to have certain limitations regarding the biofidelity and the repeatability of the test results. Therefore, Japan proposed to use a completely new legform, the so-called Flexible Pedestrian Legform Impactor (FlexPLI). In the year 2000, the Japan Automobile Manufacturers Association, Inc. (JAMA) and the Japan Automobile Research Institute (JARI) initiated development of the “Flexible Pedestrian Leg form Impactor”. In 2002, an initial design was made available, followed by the Flex-GT version in 2006. The FLEX-PLI features biomechanically based femur, tibia and knee design, with biofidelic bending characteristics. In the knee the ligaments are represented according to human anthropometry. A Technical Evaluation Group (FLEX-TEG), consisting of governmental and industrial parties evaluated the possibility to use the leg form impactor for Global Technical Regulation on Pedestrian Safety (PS-GTR). Humanetics was a member of this group as dummy manufacturer and was asked to review the GT design and manufacture the leg. This review highlighted a number of improvements and the proposed GTR design was accepted. The performance of the leg was intended to remain the same to ensure existing test data was still valid.

The main improvements were centralising the knee ligament deflection sensors to avoid impact direction sensitivity, balancing the spring force load in the knee joint to reduce knee joint twist about vertical axis, various improvements related to handling and repeatability, introduction of full bridge strain gauge

configuration, additional optional sensors and incorporating on board Data Acquisition Systems (DAS) to improve free flight motion.

Humanetics also reviewed the quasi static calibration procedures for internal bones, thigh, knee and lower leg assemblies. The pendulum dynamic calibration rig and procedure were also updated to provide more realistic loading. The high speed inverse linear guided impactor test is also a requirement for the GTR9 regulation.

The standard leg instrumentation has 12 channels; this includes 3 full bridge strain gage sensors in the thigh and 4 in the lower leg all measuring leg bending moment, an accelerometer and 4 string potentiometers in the knee, each one measures specific ligament elongation. There are also options for a further 26 linear accelerometer channels and 9 Angular Rate Sensors (ARS).

Flex GTR has symmetric design so can represent a right or left leg.

1.2 Tools Required

Several types of standard tools are used in the assembly and disassembly of the dummy. T-handle wrenches (Figure 1) and hex wrenches (Figure 2) can be used to access most of the fasteners in the dummy. In some cases, access to fasteners is easier if a ratchet offset wrench with hex bits is used (Figure 3).





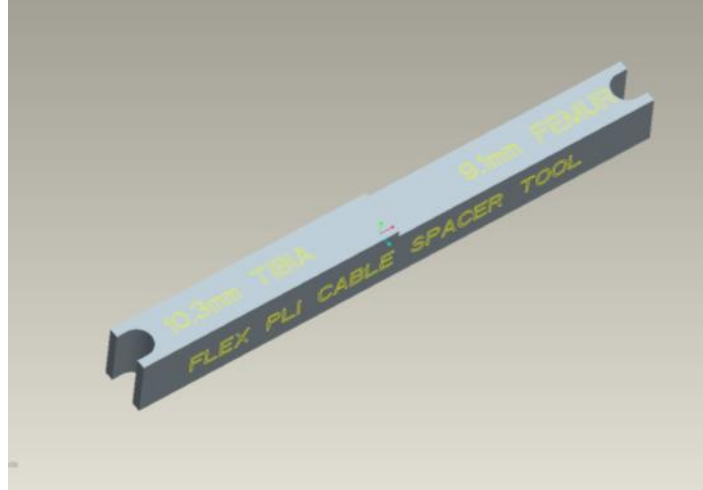

Figure 4 . Leg wire setting tool 133-5112

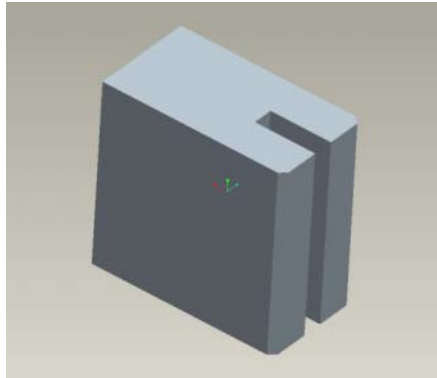

Figure 5 . Knee spacer tool 133-5113

Note: Apart from the string potentiometer #2-56 UNC cap head screws and the ARS optional angular rate sensors which use #0-80 cap heads all the leg screws are metric.

QTY	PART NO.	DESCRIPTION
1	6002565	Transport Case
25 meter roll	6002558-13	Double Sided Tape, 50mm Wide
20	5000522	M5 Nyloc Nuts
1	133-5112	Wire Setting Tool
1	5000819	Open Ended Wrench, 4mm
1	9003192	Open Ended Wrench, 1/8"
2	133-5113	Setting Tool, Knee
10	133-5025	Double Sided Tape, Impact Segment

Table 1. Contents of the tool kit provided with the leg on delivery.

Note: A strong double sided tape supplied by Teraoke is used extensively on the Flex leg. Humanetics recommends the use of this tape or a tape with the same strength to maintain performance.

Section 2. Instrumentation

2.1 Standard 12 Channel instrumentation

FLEX-PLI-GTR is offered with 12 channel standard instrumentation, measuring tibia and femur bending moments and knee ligament elongations as well as tibia acceleration in impact direction. The standard instrumentation channels are listed in Table 2. The channels intended for injury assessment are the 4 tibia bending moments, knee medial collateral ligament (MCL) elongation and ACL and PCL elongations are being monitored. These channels are controlled by the certification procedures given in Sections 8 and 9.

Instrument Channels	Purpose	Standard	DAS
Femur moment 1,2 and 3	-	3	Standard Option iDummy
Tibia moment 1,2,3 and 4	Injury Assessment	4	
Tibia Top Acceleration AX	-	1	
MCL elongation	Injury Assessment	1	
ACL elongation	Monitoring	1	
PCL elongation	Monitoring	1	
LCL elongation	-	1	
	Total	12	

Table 2. 12 Channel Instrumentation

2.2 Optional instrumentation

The FLEX-PLI offers a range of optional instrumentation for research purpose. When running regulatory tests with optional instrumentation it is recommended to check that the total mass of the tool, including a certain amount of cable length, does not exceed the regulatory requirement. Each individual femur and tibia segment can be instrumented with an accelerometer in impact direction. Tri-axial accelerometers and/or angular rate sensors are also available at various locations. It is recommended that damped accelerometers are used on FLEX PLI.

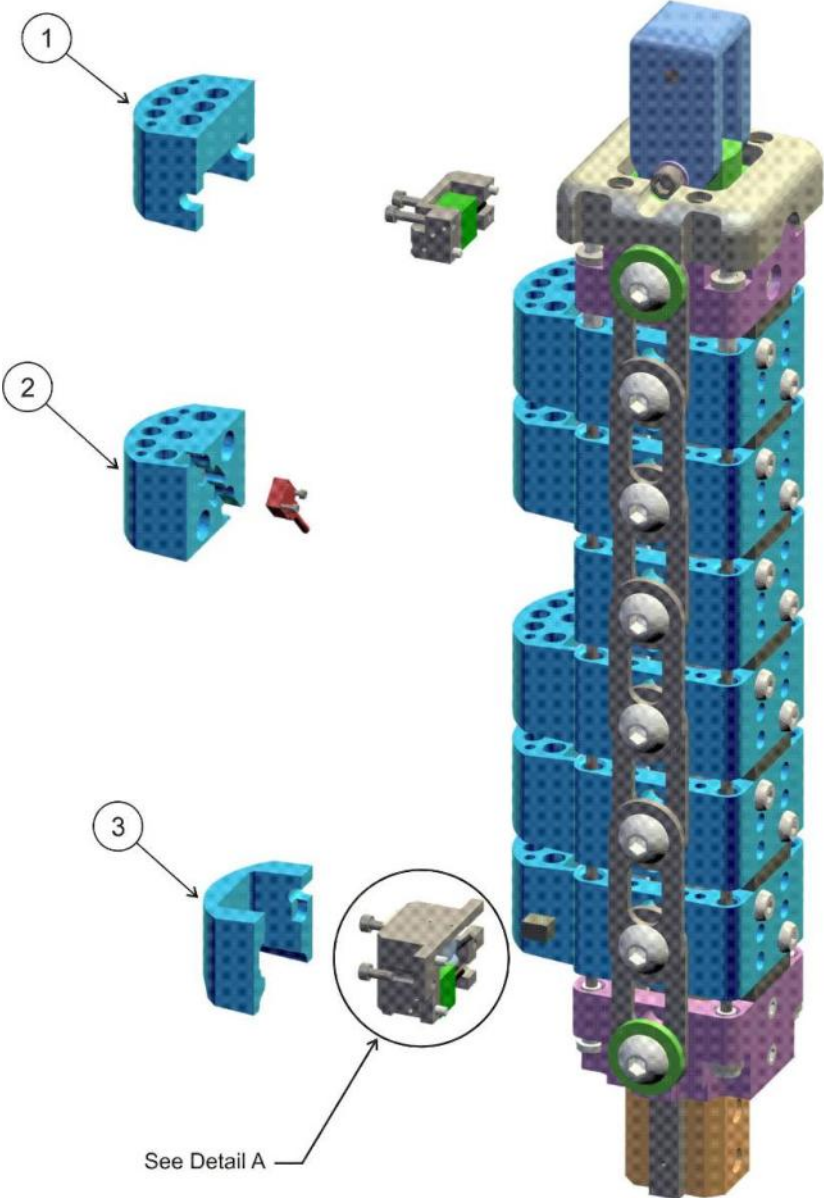

Figure 6 . Optional Instrumentation for Femur

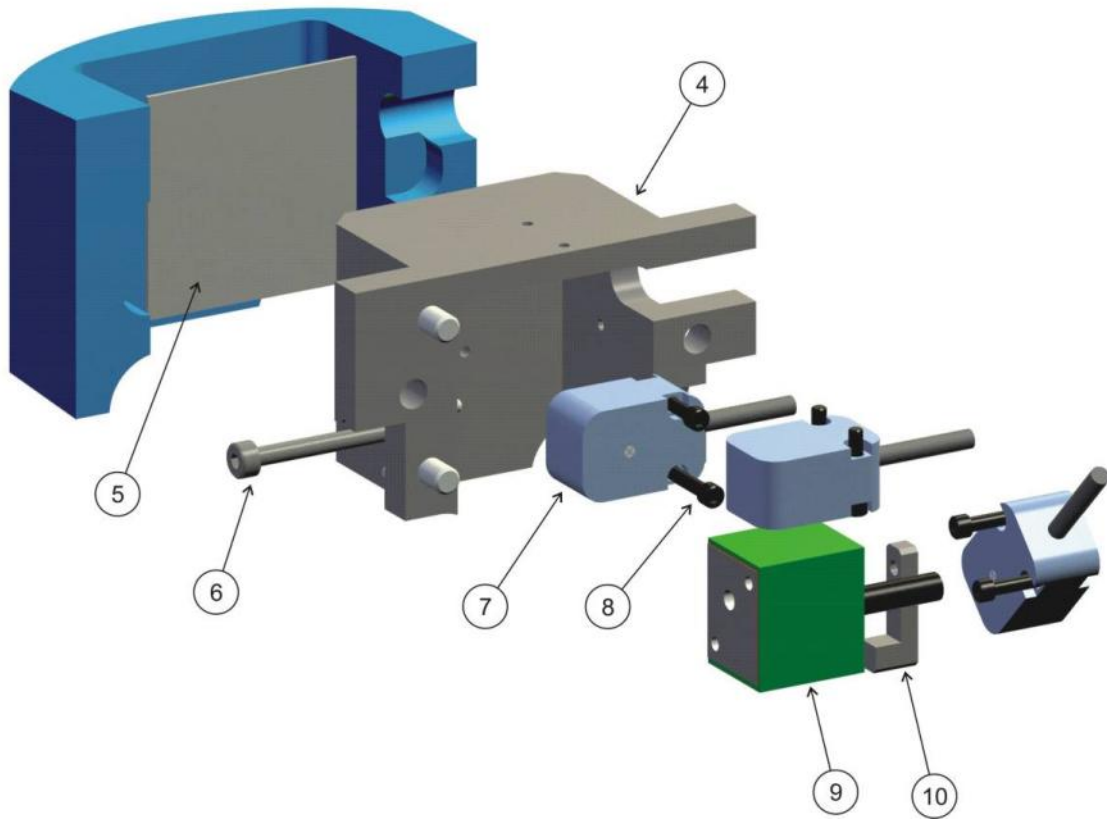

Figure 7 . Detail A, Exploded View, upper and lower knee

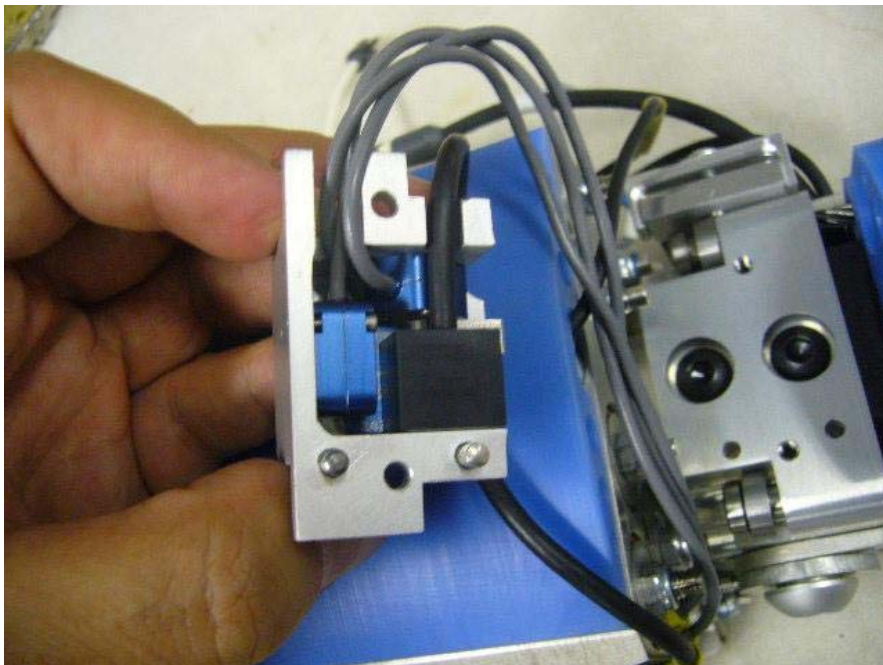

Figure 8 . Wire routing for Detail A optional sensors

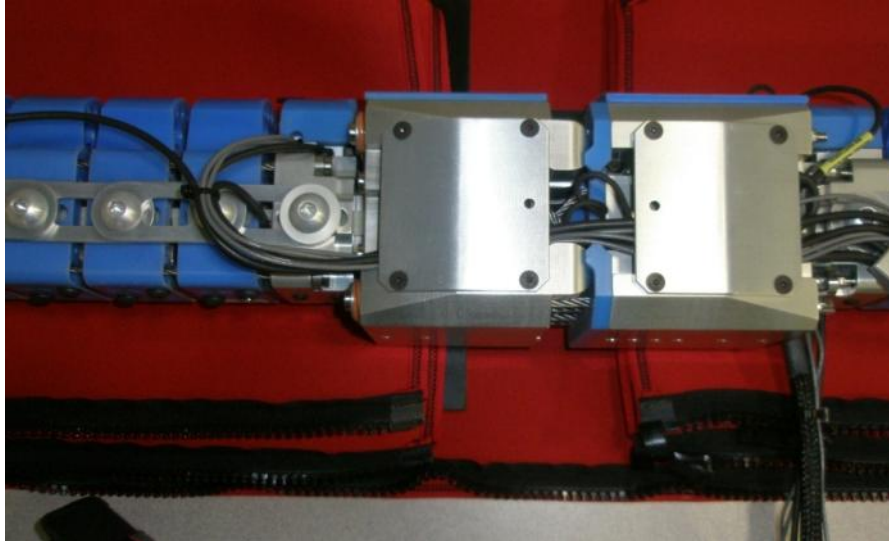

Figure 9 . Wire routing out of segment for optional sensors Detail A in upper knee

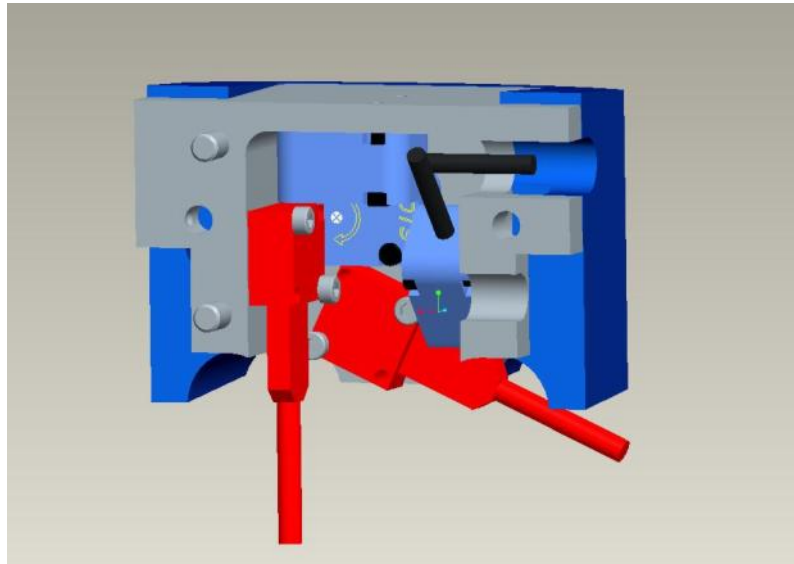

Figure 10 . Similar arrangement to Detail A, but with 2 uniax Kyowa accels. Assembly 133-7600

There is also an alternate mirror image of 133-7600 available to route wires to the opposite side to prevent wires going around the knee thus avoiding wire damage.

Sensor IES 3103 ARS triax for Detail A position used with M=BUS. A single uniax accel either a Kyowa ASE-500 or MSI model 64 or similar can also be used here with this sensor. Assembly 133-7522, Figure 11. Figure 12 shows Kyowa accelerometer option for femur top and tibia bottom locations.

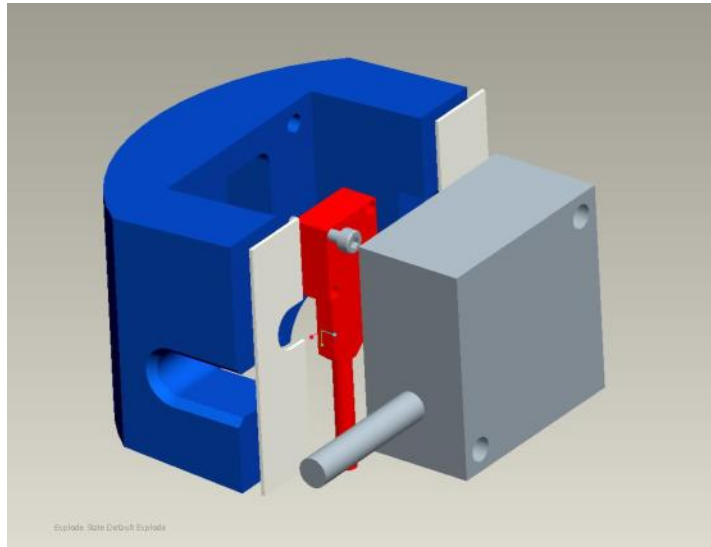

Figure 11 . Sensor IES 3103 ARS triax for Knee upper and lower used with M=BUS, (mount 133-7522)

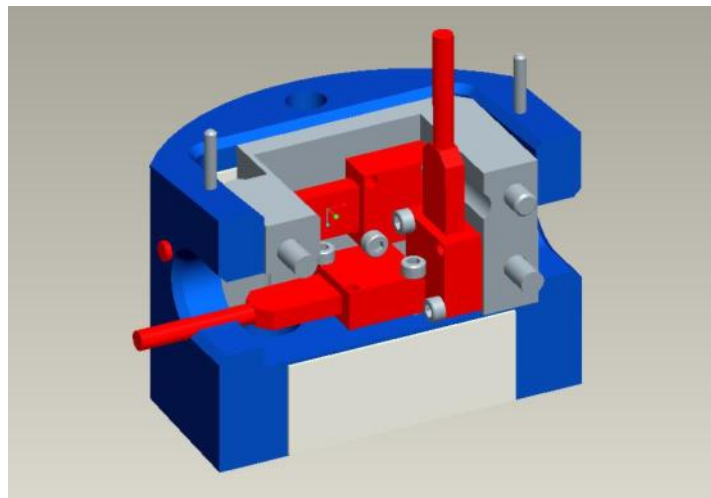

Figure 12 . Kyowa accel 3 axis option for leg top and bottom locations, (mount 133-7530)

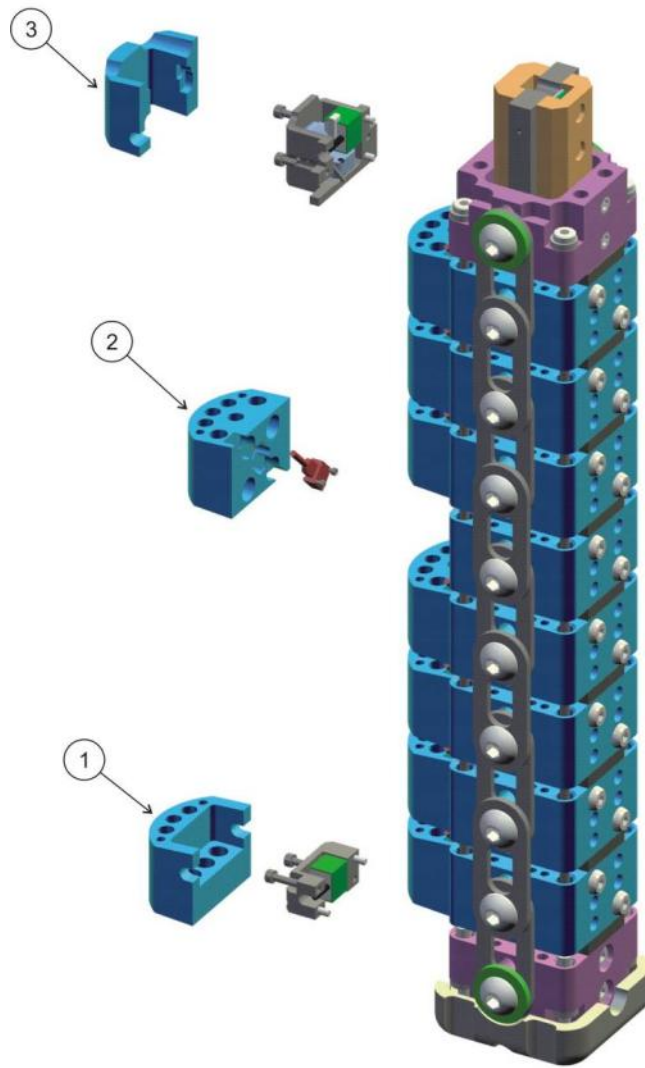

Figure 13 . Optional Instrumentation, for Tibia

ITEM	QTY	PART NO.	DESCRIPTION
1	1	133-7508	ACCEL INSTRUMENTED OPTION LEG TOP & BOTTOM
2	6	133-7514	IMPACT SEGMENT - INSTRUMENTED ASSEMBLY (FEMUR)
2	8	133-7514	IMPACT SEGMENT - INSTRUMENTED ASSEMBLY (TIBIA)
3	1	133-7507	ACCEL & ARS INSTRUMENTED OPTION FOR KNEE
4	1	133-7502	KNEE END ACCEL MOUNT
5	1	133-7516	TAPE, DOUBLE SIDED
6	1	5000164	SCREW, SHCS M2 X 0.4 X 18
7	3	IT-TBD	DTS ANGULAR RATE SENSOR
8	6	9003103	SCREW, SHCS #0-80 X 5/16
9	1	MS-68C	ACCELEROMETER, LINEAR TRIAXIAL, MEASUREMENT SPECIALTIES MS 68C
10	1	133-7506	SPECIAL M2 ACCEL FIXING

Table 3. Example of Optional Instrumentation Parts List

2.3 ISO MME Codes

For the identification of sensor channels and for computer processing of signals the following codes have been established for ISO MME.

No.	Location (Description)	Category	Test Object	Position	Transd Main Location	Fine Location 1	Fine Location 2	Fine Location 3	Physical Dimension	Direction	Filter Class
1	Femur Moment 3 Upper, X	standard	0	0	FEMR	UP	00	PF	MO	X	C
2	Femur Moment 2 Middle, X	standard	0	0	FEMR	MI	00	PF	MO	X	C
3	Femur Moment 1 Lower, X	standard	0	0	FEMR	LO	00	PF	MO	X	C
4	Knee LCL Elongation	standard	0	0	KNEE	LC	00	PF	DS	Z	C
5	Knee ACL Elongation	standard	0	0	KNEE	AC	00	PF	DS	Z	C
6	Knee PCL Elongation	standard	0	0	KNEE	PC	00	PF	DS	Z	C
7	Knee MCL Elongation	standard	0	0	KNEE	MC	00	PF	DS	Z	C
8	Tibia Moment 1 Upper, X	standard	0	0	TIBI	UP	00	PF	MO	X	C
9	Tibia Moment 2 Middle Upper, X	standard	0	0	TIBI	MI	UP	PF	MO	X	C
10	Tibia Moment 3 Middle Lower, X	standard	0	0	TIBI	MI	LO	PF	MO	X	C
11	Tibia Moment 4 Lower, X	standard	0	0	TIBI	LO	00	PF	MO	X	C
12	Knee Bottom Acceleration, Y	standard	0	0	KNEE	BO	00	PF	AC	Y	C
13	Femur Top Acceleration, X	additional	0	0	FEMR	TP	00	PF	AC	X	C
14	Femur Top Acceleration, Y	additional	0	0	FEMR	TP	00	PF	AC	Y	C
15	Femur Top Acceleration, Z	additional	0	0	FEMR	TP	00	PF	AC	Z	C
16	Femur Segment 1 Acceleration, Y	additional	0	0	FEMR	01	00	PF	AC	Y	C
17	Femur Segment 2 Acceleration, Y	additional	0	0	FEMR	02	00	PF	AC	Y	C
18	Femur Segment 3 Acceleration, Y	additional	0	0	FEMR	03	00	PF	AC	Y	C
19	Femur Segment 4 Acceleration, Y	additional	0	0	FEMR	04	00	PF	AC	Y	C
20	Femur Segment 5 Acceleration, Y	additional	0	0	FEMR	05	00	PF	AC	Y	C

21	Femur Segment 6 Acceleration, Y	additional	0	0	FEMR	06	00	PF	AC	Y	C
22	Knee Upper Acceleration, X	additional	0	0	KNEE	UP	00	PF	AC	X	C
23	Knee Upper Acceleration, Y	additional	0	0	KNEE	UP	00	PF	AC	Y	C
24	Knee Upper Acceleration, Z	additional	0	0	KNEE	UP	00	PF	AC	Z	C
25	Knee Upper Angular Rate, ωX	additional	0	0	KNEE	UP	00	PF	AV	X	C
26	Knee Upper Angular Rate, ωY	additional	0	0	KNEE	UP	00	PF	AV	Y	C
27	Knee Upper Angular Rate, ωZ	additional	0	0	KNEE	UP	00	PF	AV	Z	C
28	Knee Lower Acceleration, X	additional	0	0	KNEE	LO	00	PF	AC	X	C
29	Knee Lower Acceleration, Y	additional	0	0	KNEE	LO	00	PF	AC	Y	C
30	Knee Lower Acceleration, Z	additional	0	0	KNEE	LO	00	PF	AC	Z	C
31	Knee Lower Angular Rate, ωX	additional	0	0	KNEE	LO	00	PF	AV	X	C
32	Knee Lower Angular Rate, ωY	additional	0	0	KNEE	LO	00	PF	AV	Y	C
33	Knee Lower Angular Rate, ωZ	additional	0	0	KNEE	LO	00	PF	AV	Z	C
34	Tibia Segment 1 Acceleration, Y	additional	0	0	TIBI	01	00	PF	AC	Y	C
35	Tibia Segment 2 Acceleration, Y	additional	0	0	TIBI	02	00	PF	AC	Y	C
36	Tibia Segment 3 Acceleration, Y	additional	0	0	TIBI	03	00	PF	AC	Y	C
37	Tibia Segment 4 Acceleration, Y	additional	0	0	TIBI	04	00	PF	AC	Y	C
38	Tibia Segment 5 Acceleration, Y	additional	0	0	TIBI	05	00	PF	AC	Y	C
39	Tibia Segment 6 Acceleration, Y	additional	0	0	TIBI	06	00	PF	AC	Y	C
40	Tibia Segment 7 Acceleration, Y	additional	0	0	TIBI	07	00	PF	AC	Y	C
41	Tibia Segment 8 Acceleration, Y	additional	0	0	TIBI	08	00	PF	AC	Y	C

42	Tibia Bottom Acceleration, X	additional	0	0	TIBI	BO	00	PF	AC	X	C
43	Tibia Bottom Acceleration, Y	additional	0	0	TIBI	BO	00	PF	AC	Y	C
44	Tibia Bottom Acceleration, Z	additional	0	0	TIBI	BO	00	PF	AC	Z	C

Table 4. ISO MME Sensor Code table

Location (Description)	Wire Label Code	TRIAX Sensor wire label code	ISOMMECODE
Femur Moment 3 Upper, X	F3	F1-3	00FEMRUP00PFMOXC
Femur Moment 2 Middle, X	F2		00FEMRMI00PFMOXC
Femur Moment 1 Lower, X	F1		00FEMRLO00PFMOXC
Knee LCL Elongation	LCL		00KNEELC00PFDSZC
Knee ACL Elongation	ACL		00KNEEAC00PFDSZC
Knee PCL Elongation	PCL		00KNEEPC00PFDSZC
Knee MCL Elongation	MCL		00KNEEMC00PFDSZC
Tibia Moment 1 Upper, X	T1	T1-3	00TIBIUP00PFMOXC
Tibia Moment 2 Middle Upper, X	T2		00TIBIMIUPPFMOXC
Tibia Moment 3 Middle Lower, X	T3		00TIBIMILOPFMOXC
Tibia Moment 4 Lower, X	T4		00TIBILO00PFMOXC
Knee Bottom Acceleration, Y	AY-KB		00KNEEBO00PFCAYC
Femur Top Acceleration, X	AX-FT	A-FT	00FEMRTP00PFACXC
Femur Top Acceleration, Y	AY-FT		00FEMRTP00PFACYC
Femur Top Acceleration, Z	AZ-FT		00FEMRTP00PFACZC
Femur Segment 1 Acceleration, Y	AY-S1		00FEMR0100PFACYC
Femur Segment 2 Acceleration, Y	AY-S2		00FEMR0200PFACYC
Femur Segment 3 Acceleration, Y	AY-S3		00FEMR0300PFACYC
Femur Segment 4 Acceleration, Y	AY-S4		00FEMR0400PFACYC
Femur Segment 5 Acceleration, Y	AY-S5		00FEMR0500PFACYC
Femur Segment 6 Acceleration, Y	AY-S6		00FEMR0600PFACYC
Knee Upper Acceleration, X	AX-KU	A-KU	00KNEEUP00PFACXC
Knee Upper Acceleration, Y	AY-KU		00KNEEUP00PFACYC
Knee Upper Acceleration, Z	AZ-KU		00KNEEUP00PFACZC
Knee Upper Angular Rate, ωX	ARX-KU	AR-KU	00KNEEUP00PFAVXC
Knee Upper Angular Rate, ωY	ARY-KU		00KNEEUP00PFAVYC
Knee Upper Angular Rate, ωZ	ARZ-KU		00KNEEUP00PFAVZC
Knee Lower Acceleration, X	AX-KL	A-KL	00KNEELO00PFACXC
Knee Lower Acceleration, Y	AY-KL		00KNEELO00PFACYC
Knee Lower Acceleration, Z	AZ-KL		00KNEELO00PFACZC
Knee Lower Angular Rate, ωX	ARX-KL	AR-KL	00KNEELO00PFAVXC
Knee Lower Angular Rate, ωY	ARY-KL		00KNEELO00PFAVYC
Knee Lower Angular Rate, ωZ	ARZ-KL		00KNEELO00PFAVZC
Tibia Segment 1 Acceleration, Y	AY-S7		00TIBI0100PFACYC
Tibia Segment 2 Acceleration, Y	AY-S8		00TIBI0200PFACYC
Tibia Segment 3 Acceleration, Y	AY-S9		00TIBI0300PFACYC
Tibia Segment 4 Acceleration, Y	AY-S10		00TIBI0400PFACYC
Tibia Segment 5 Acceleration, Y	AY-S11		00TIBI0500PFACYC
Tibia Segment 6 Acceleration, Y	AY-S12		00TIBI0600PFACYC

Tibia Segment 7 Acceleration, Y	AY-S13		00TIBI0700PFACYC
Tibia Segment 8 Acceleration, Y	AY-S14		00TIBI0800PFACYC
Tibia Bottom Acceleration, X	AY-TB	A-TB	00TIBIBO00PFACXC
Tibia Bottom Acceleration, Y	AY-TB		00TIBIBO00PFACYC
Tibia Bottom Acceleration, Z	AZ-TB		00TIBIBO00PFACZC

Table 5. Wire label codes for all sensors

2.3.1 Co-ordinate System

The recommended local co-ordinate system for standardization follows the SAE J-211 dummy co-ordinate system.

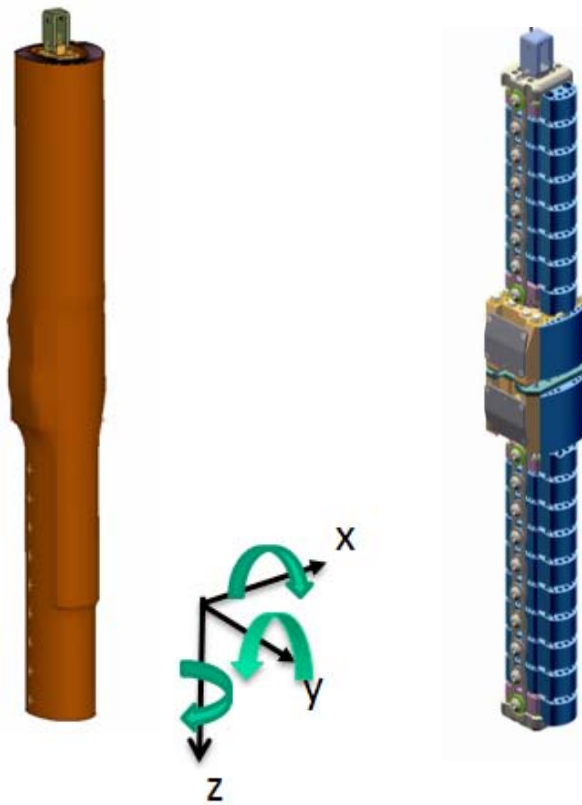

Figure 14 . Leg Local Sign Convention

2.3.2 Signal Polarity, Sensor function check

The leg can be manipulated manually as shown in Figure 15 below to test polarity and function for positive output. A spacer can be placed under the leg to assist in the bending of the leg. The positive outputs shown in Figure 15 below are preferred for standardization; users can use their own polarity if required.

For accelerometers signal polarity a blow in the direction of the positive axis should result in a positive acceleration output (Figure 14). Example: a blow (f.i. with a wooden hammer) on the blue impact cover in negative y-direction should give a negative y-acceleration.

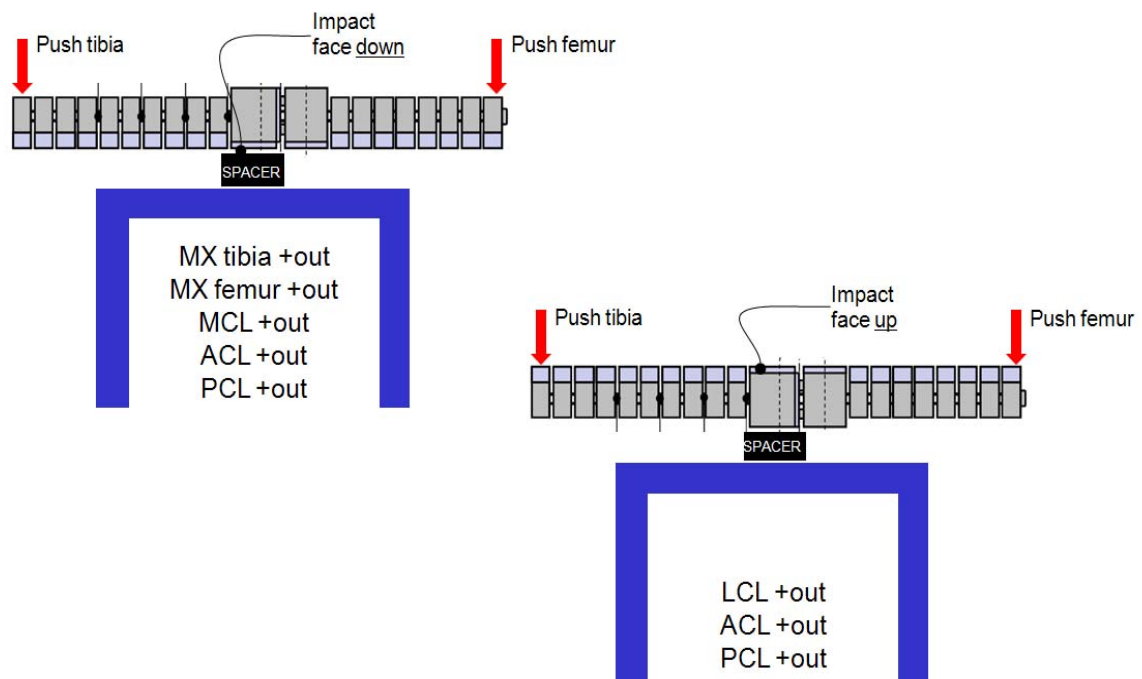

Figure 15 . Leg manipulations for positive output

2.3.3 Filter Class

The filter class to be used on the Flex PLI is CFC180 for all channels.

2.4 Data Acquisition Options

The FLEX PLI can be used with various options for data acquisition systems. The most basic version is a system with connection cables to a static laboratory Data Acquisition System (DAS), the so called off-board DAS option. As the FLEX-PLI is a tool that is in free flight after launch, the off board cables may affect the free flight trajectory accuracy and the cables are susceptible to damage when the tool lands after rebound from the vehicle. Therefore the use of off board DAS is not recommended. Currently Humanetics can provide onboard DAS systems from Messring, DTS, Hentschel, Kayser-Threde and Kyowa. These systems are described in paragraphs 2.6, 2.7, 2.8 and 2.9. This section is provided in the manual for information only. For detailed and up to date information on DAS systems, please refer to the original DAS equipment manufacturer.

2.5 Off Board DAS

For off board DAS umbilical cables of 10m long exit the leg just below the knee. This position is close to the CG of the leg to minimize the mass affect from the cables in free flight. The cables are clamped to the leg via the top shoulder link bolts of the tibia to provide restraint protection to the connectors see Figure 16. See Figure 17 for left hand side wiring arrangement. The connectors at the off board DAS side are specified by the customer and fitted by Humanetics as all users have different systems.

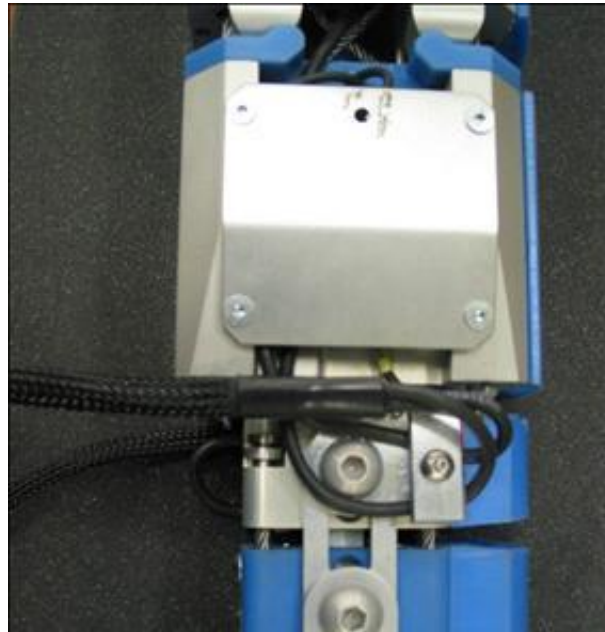

Figure 16 . Clamping Arrangement and Position for Off board Wires

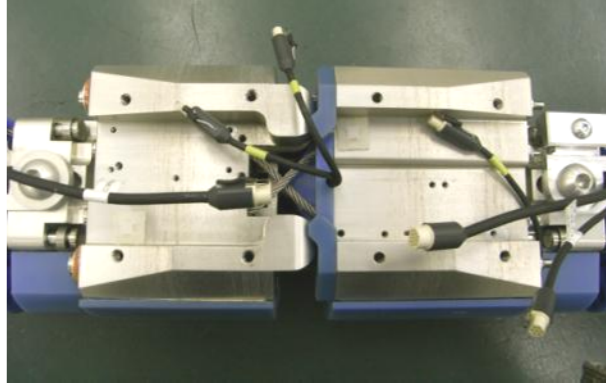

Figure 17 . Off Board wiring left hand side of impact face

Most of the wiring for the off board configuration is in the tibia block. Only the femur bone wire passes over the knee joint, see Figure 18 for wiring on right hand side.

All the sensors use miniature round connectors with locking latch, either a 7 pin or 16 pin is used. The 16 pin connectors are for the 3 femur strain gages and for 3 of the 4 tibia strain gages. 16 pin connectors are also used for optional triaxial accelerometers.

All the sensor wires are identified to ensure correct connection.

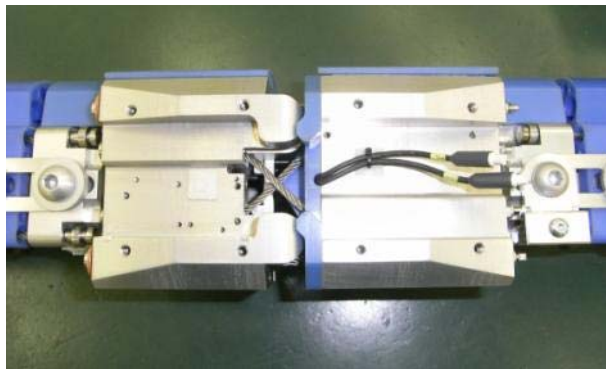

Figure 18 . Off Board wiring right hand side of impact face

The leg wires must be balanced to ensure good free flight after launch with 6 channels each side. On the right side are 2 single channel string pots, 1 single channel accelerometer and 1 three channel wire for the three femur bone gages. On the left side there are 2 single channel string pots, 1 single channel tibia bone gage and 1 three channel wire for the other tibia bone gages.

It is important to route the off board cables out of the knee to ensure good free flight to the target. See Figure 14 for an example. Users can establish their own wire routing but the important issues to note are that both sides are balanced and there is no restriction at release from the pusher plate when fired.

2.6 Messring M=BUS On Board Data Acquisition

2.6.1 M=BUS description

An overview of the M=BUS system is shown in Figure 19. The M=BUS is a 6 channel logger fitted inside an aluminium housing; connection is made to the logger via a plug in PCB board. Each logger has its own battery. For the standard 12 channels there are two M=BUS units one either side of the knee in the tibia knee block, three M3 FHCS fix the units to the knee. The sensor connection is made by either a 7 pin or 16 pin miniature round connector with locking latch. For M=BUS left hand side of leg see Figure 20. For detailed use and specifications please refer to the suppliers user instructions.

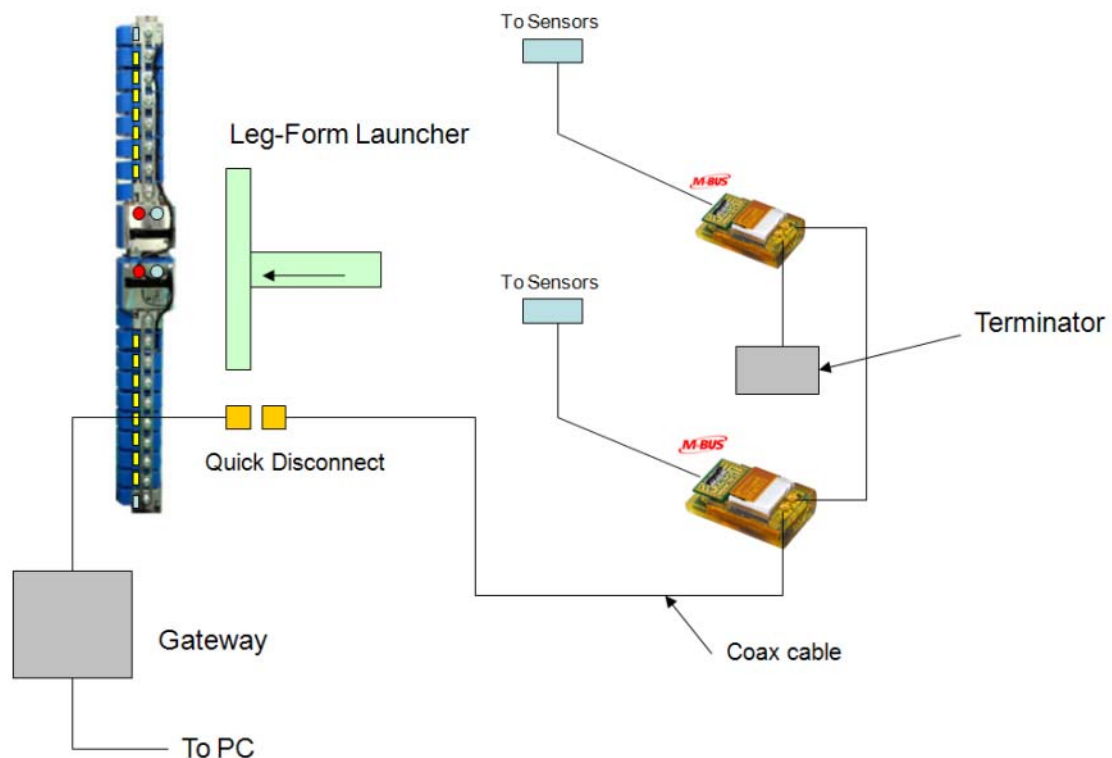

Figure 19 . Wiring Diagram for 12 channel M=BUS

For leg wire routing please refer to Figure 20 below, this is typical for both sides.

The disconnect wire is a blue coax cable, the brass end fitting can be clamped to one of the off board cable clamps just below the knee see Figure 22. This direct clamping avoids any damage to the connector. Be careful not to crush the connector when clamping. Only one cable clamp requires fitting for Messring installation. A hole also has to be cut in the outer red cover to allow exit of the cable if this exit location is used. Users can also route the disconnect out of the top of the leg to avoid cutting the outer red cover, a longer disconnect wire would be needed for this.

After the test the disconnect is reconnected and data can be downloaded to a PC installed with the Messring Crashsoft software.

Inside the femur block there is a terminator housing to complete the coax wiring, see Figure 23, two M3 SHCS retain the part. The terminator can only be accessed when the knee is disassembled. If the knee is stripped down for access it is recommended the knee is recertified.

The loggers are programmed to specific sensors for sensitivity, range and software recognition. Loggers cannot change location and connector labels must match to ensure connection to the sensor.

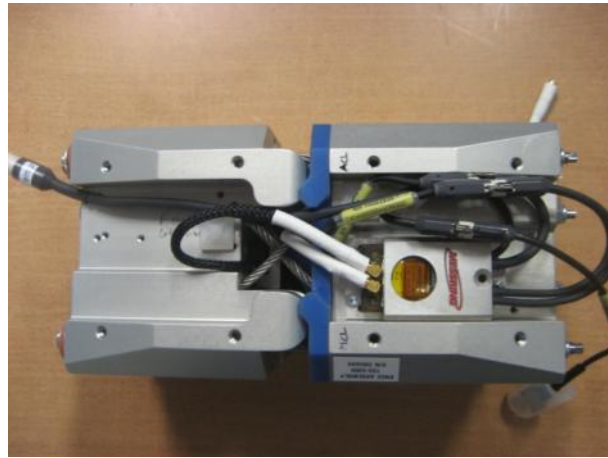

Figure 20 . M=BUS arrangement in knee 12 channels LH side to impact direction

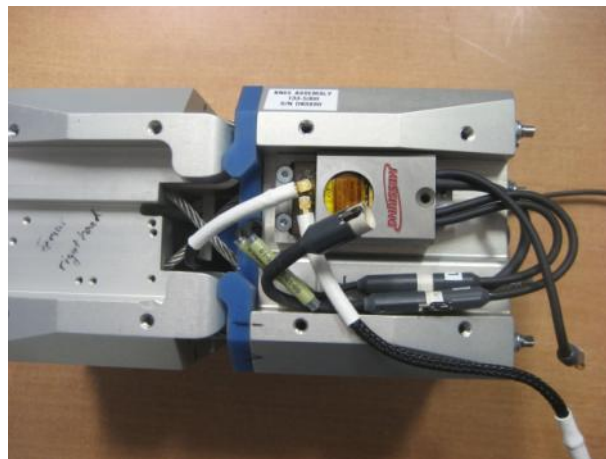

Figure 21 . M=BUS arrangement 12 channels RH side of impact direction

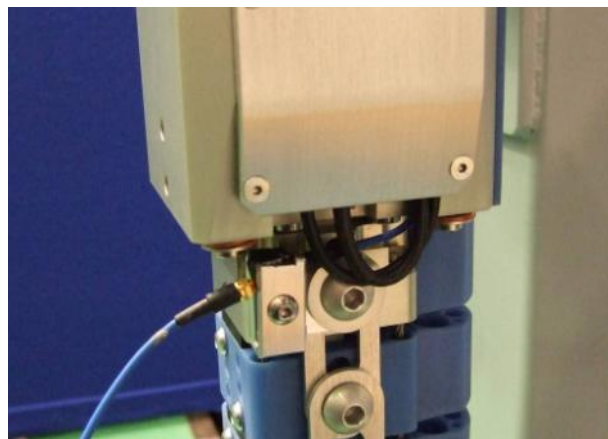

Figure 22 . Clamping of M=BUS Disconnect Connector

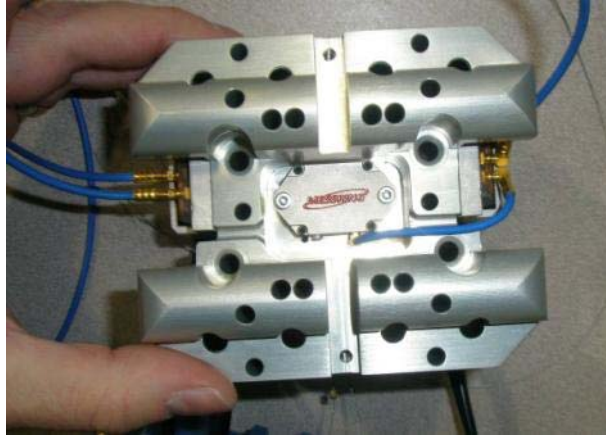

Figure 23 . M=BUS Terminator housing installation in upper knee

Figure 24, shows the M=BUS disconnect wire on the launcher and how the coax wire is routed and fixed to the launcher. The disconnect design has a low release force, however a strong tape is recommended to hold the wire in place.



Figure 24 . Fixing M=BUS Wire to Launcher

2.6.2 24 Channel M=BUS

Four, six channel loggers can be fitted to the leg to provide 24 channels of data recording. See figures below for typical installation. Wire connections can vary according to optional sensors installed.



Figure 25 . Right hand side of knee M=BUS 24 channels, sensors not connected

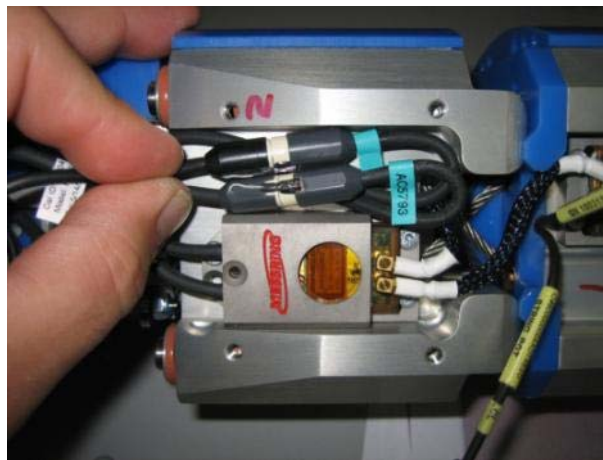

Figure 26 . Top right hand side of knee M=BUS 24 channels, sensors connected



Figure 27 . Bottom right hand side of knee M=BUS 24 channels, sensors connected

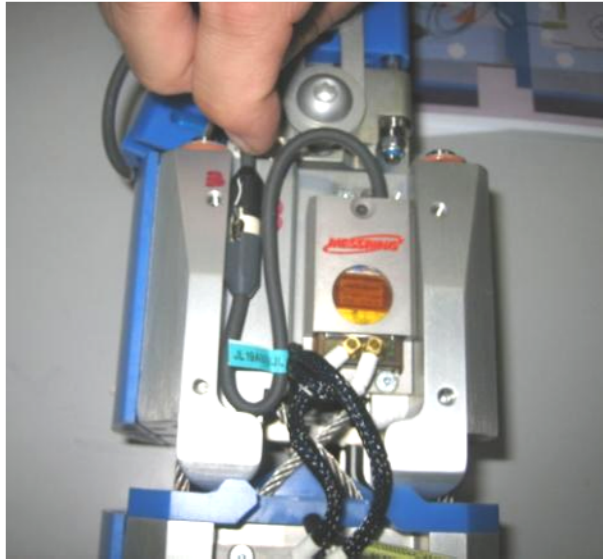

Figure 28 . Top left hand side of knee Messring 24 channels sensors connected



Figure 29 . Bottom left hand side of knee M=BUS 24 channels, sensors connected

2.7 DTS Onboard SLICE Nano DAS

For detailed use and specifications please refer to suppliers user instructions.

The SLICE is a modular system where a 3 channel bridge SLICE can be stacked onto a base SLICE; in this case one base SLICE handles 12 channels of data. As the FLEX-PLI has limited space to package the SLICE stack a mounting board has been designed by DTS to link four bridges together allowing one base SLICE to be used. The unit is fixed using four M3 pozi head screws. Sensor connection to the DAS is via either 7 or 16 pin round miniature connectors see Figure 30 & 31 for 12 channel wiring arrangement. After disconnect the SLICE is powered by a Super capacitor mounted on the same side of the knee as the standard 12 channel DAS See Figure 31. The super capacitor is quickly charged when reconnected. The wire disconnect is a round 12 pin connector hard mounted to the launch guide bracket at the top of the femur see Figure 32. This disconnect position allows disconnect in the push phase from the launcher to avoid the connector affecting free flight stability. On reconnect the test data can be downloaded to a PC.

If required there is provision to wire in a tape switch for T=0, a wire is provided for this option out of the super cap housing.

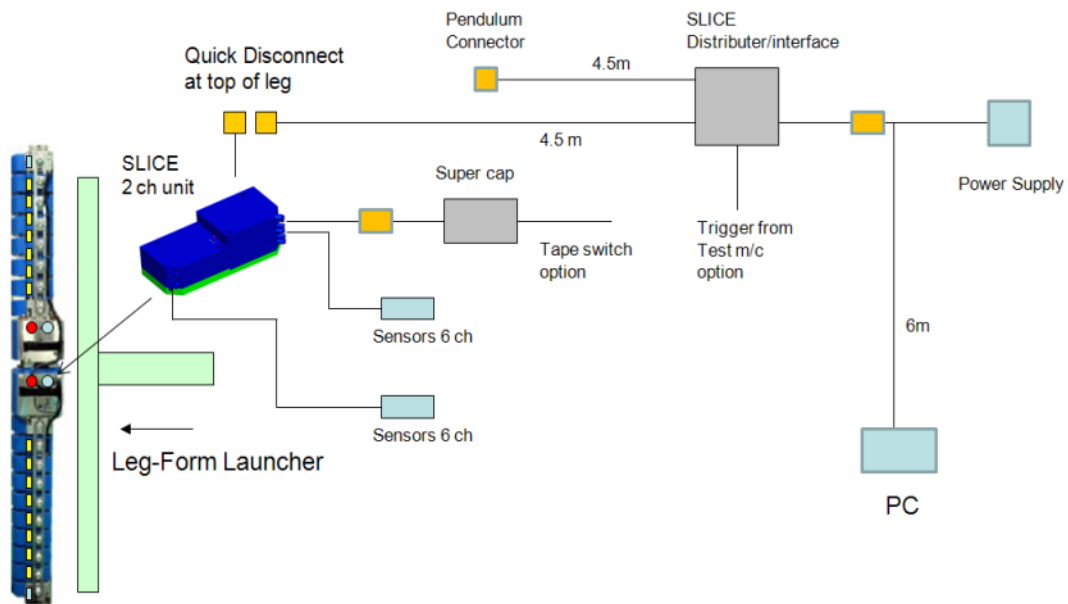

Figure 30 . Wiring diagram for 12 channel SLICE

Typical Slice wiring to knee with SLICE units, on the right in tibia knee block and super cap on the left in femur knee block, Figure 31.



Figure 31 . Typical 12 channel Slice wiring to knee

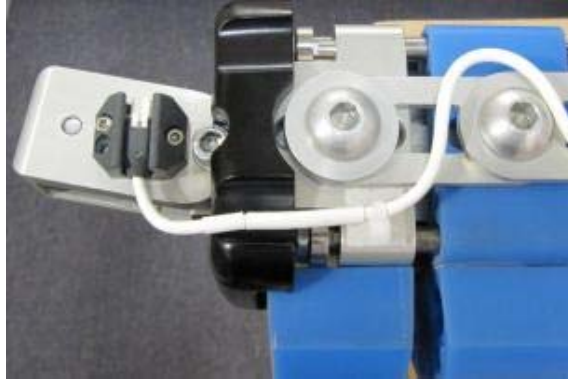

Figure 32 . SLICE disconnect connector

To assemble the SLICE fit the SLICE unit with the higher stack part closest to the knee joint as shown in Figure 31 using four M3 Pozi type screws two 25mm and two 20mm long. Then fit the super capacitor with the disconnect wire pointing downward towards the tibia using four M3 x 16 long screws. All the connectors are identified so connect like for like, MCL to MCL etc. For the two string pot wires that pass across the knee tie wrap mounts are provided both sides to anchor the wires, see Figure 34 showing connectors on the right hand side of the knee. Route the wires as shown to provide adequate slack in the knee joint to prevent any disconnection or damage to the wires when the knee flexes. The disconnect bracket is fixed to the launch guide as shown in Figure 32 using M2.5 screws and the 12 pin connector is mated with the connector coming out of the bottom of the base SLICE. Most of the wires and connectors are behind the knee covers but the gage wires coming out of the leg must be properly restrained. There should be two tie wraps fixing the bone gage wires coming out of each bone (tibia and femur) to the end link where it exits the leg. Before fitting the covers note there are two covers with three holes, one of these covers part 133-5314 must be fitted over the SLICE unit for screw head clearance as shown in Figure 33, the other cover 133-5315 is necessary for 24 channel DAS when two SLICE units are fitted. If 24 channels are not being used this cover can go to any of the other three locations.



Figure 33 . LH of leg with knee covers fitted 12 channels. Leg wires are not shown secured.

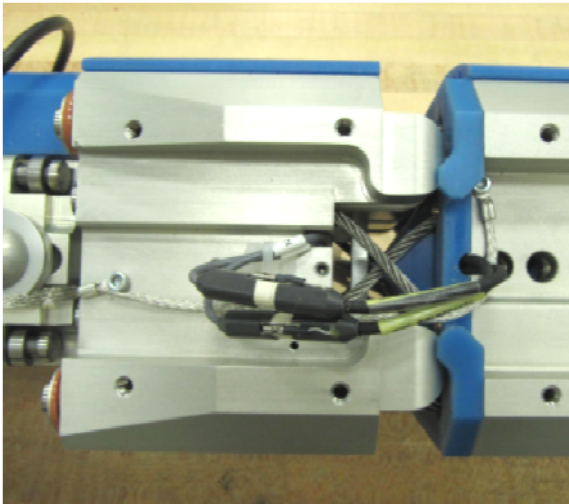

Figure 34 . Right hand side of knee 12 channels showing connectors



Figure 35 . Leg with disconnect wire, TDAS interface and power supply

2.7.1 SLICE 24 Channel Option

To complete the system to 24 channels for optional instrumentation, an additional 12 channel SLICE unit is packaged on the opposite side to the standard 12 channel units in the upper knee for balance and for access to upper leg sensors to reduce the number of wires crossing the knee joint. See below. The arrangement of SLICE bridge units and wiring will vary depending on the optional sensors selected.



Figure 36 . Optional SLICE unit 24 channel option (right side)



Figure 37 . Left side wiring example of 24 channel SLICE

2.7.2 Electrical Interference

The SLICE system has been designed with protective circuitry for EMI (Electro Magnetic Interference), RFI (Radio Frequency Interference) and ESD (Electro Static Discharge), up to 8000 V. Since Flex PLI can generate ESD due to its Nylon covered suit and parts the following best practices should be considered.

1. Use of anti-static spray inside the red skin covers. These sprays work by making it more difficult for static charge to build up on non metallic surfaces.
2. Ground all test fixtures, test articles and even Flex PLI. A ground wire could be a small expendable wire off board. Although an inconvenience on a wireless device this would be a simple way to prevent ESD and maintain data quality.

3. Any metal parts with mounted sensors should have good continuity back to the knee blocks where the DAS is mounted. An earthing kit for 12 or additional channels can be provided.
4. If possible keep laboratory humidity at a level sufficient to prevent dry conditions as dry conditions promote static build up.

2.8 DTI Hentschel Onboard DAS

2.8.1 DTI Description

The DTI (Digitized Transducer Interface) DAS consists of three hubs (Figure 38 & 39), a 48 channel Hentschel data recorder (X3) from type 327.04 and an LED quick release unit (Figure 38). The LED shows the status of the DAS using numerous color signals, an overview of the status signals can be found in the recorder manual. The quick release is achieved through a modified Lemosa 2F connector. Depending on the channel configuration one hub may be removed if not needed.

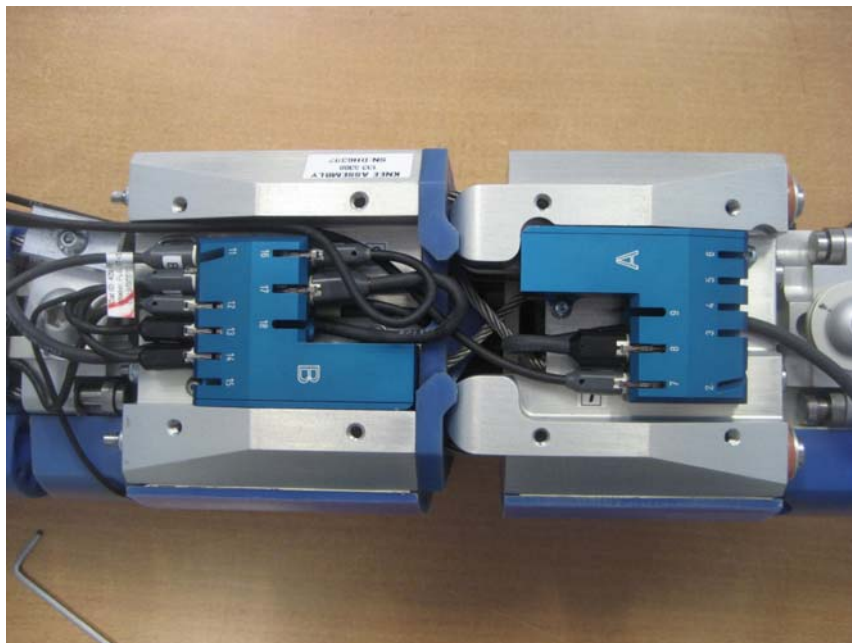

Figure 38 . DTI DAS left hand side of knee showing Di Mod hubs

The hubs contain the DiMods (Digitized Modules) for each of the sensors; each hub is engraved with a letter (A; B; C). The DiMods store individual sensor data then it is transferred to the recorder at a slower rate to ensure data quality. The DiMods for the attached sensors are located within the hub, it is therefore imperative that the correct sensor is connected to the corresponding port. To achieve this both the connector sensor side and the port have been labeled uniquely. Each hub has 9 ports. 7 x 7 pin and 2 x 16 Pin. The six 7 pin ports that are positioned away from the centre of the knee are sensor ports, as are the two 16 pins ports. The 7 pin ports that are closest to the middle of the knee (Nr.7, 16, 25) are for the data recorder bus line.



Figure 39 . DTI DAS right hand side of knee showing crash recorder on the left and DiMod hub on the right.

There is no standard configuration for the DTI leg. The configuration of the leg is set by the customer and the sensors and hubs are configured according to these wishes. The maximum number of channels this system can theoretically supply is 36; this system is therefore capable of keeping pace with possible future developments of the FlexPLI. Figure 40 shows a schematic overview of the system set up.

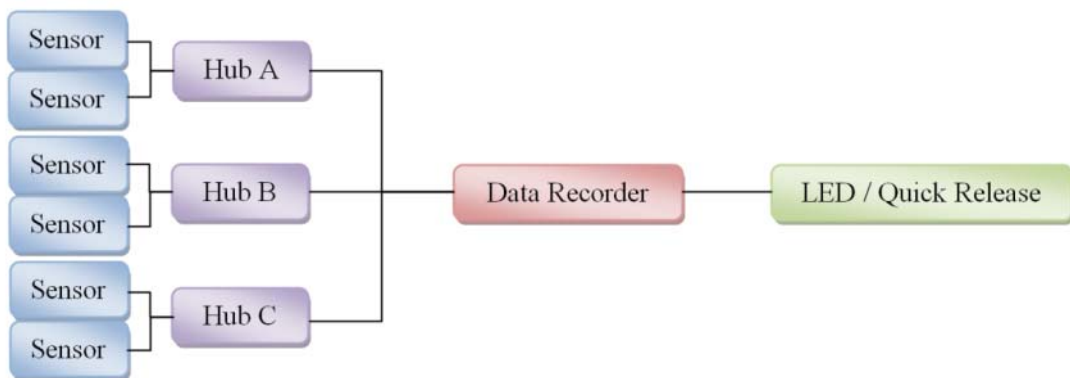

Figure 40 . DTI DAS General Overview

The sensors (including the leg bones) require calibration with the DTI DAS as a complete unit. If a sensor is changed the dimod has to be physically reconfigured and calibrated to allow for changes in the sensitivity.

2.9 KT MicroDAU Onboard DAS

2.9.1 MicroDAU Description

The Flex PLI leg can be configured to use a KT MicroDAU onboard data acquisition system. This configuration is a 12 channel system with battery backup and USB communication. The design allows any existing leg to have a MicroDAU iDummy configuration with minimal additional parts. MicroDAU modules are designed to replace the knee covers over each of the four knee cavities with three to six channels in each cavity. A lithium battery is provided for approximately 30 minutes of standalone operation.

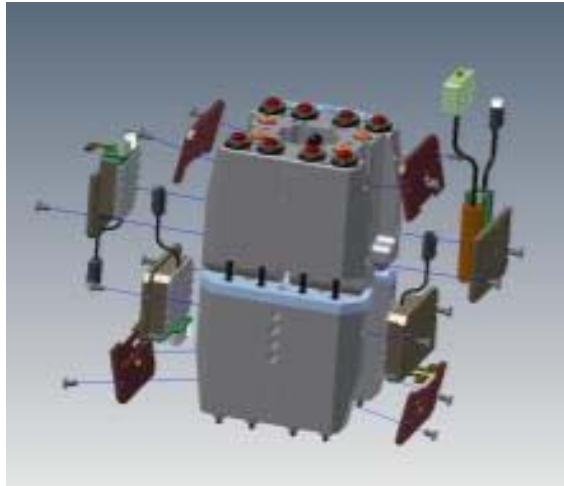

Figure 41 . Exploded view of knee showing Micro Dau integration

The MicroDAU configured leg requires 5.0v input at 600mA during operation using USB communication through the standard Kistler Crash Designer software. For detailed operation of the MicroDAU system and Crash Designer software please refer to Kistler documentation.

The MicroDAU system consists of 4 modules. The battery module (133-5713) contains the battery, charger, USB hub, the leg power/comm exit cable and communication to the rest of the modules. The battery is lithium/manganese chemistry and provides power for 30 minutes of operation. Three additional sensor modules (133-5710, 133-5711 and 133-5712) contain 3 or 6 data acquisition channels. Each module provides connectors for single channels, such as potentiometers or three channels such as femur or tibia moments. Modules 133-5711 and 133-5712 also provide power/comm inputs and outputs while module 133-5710 contains only power/comm inputs.

Modules are designed to be 'daisy chained' as shown in Figure 42. The battery module begins the chain, with each module connected to next module. Module 133-5710 is the last module in the chain. Clearance is provided under each module for power/comm and sensor cables. The clearance is tight due to space restraints so care must be take to assure cables are not overlapping or pinched during assembly.

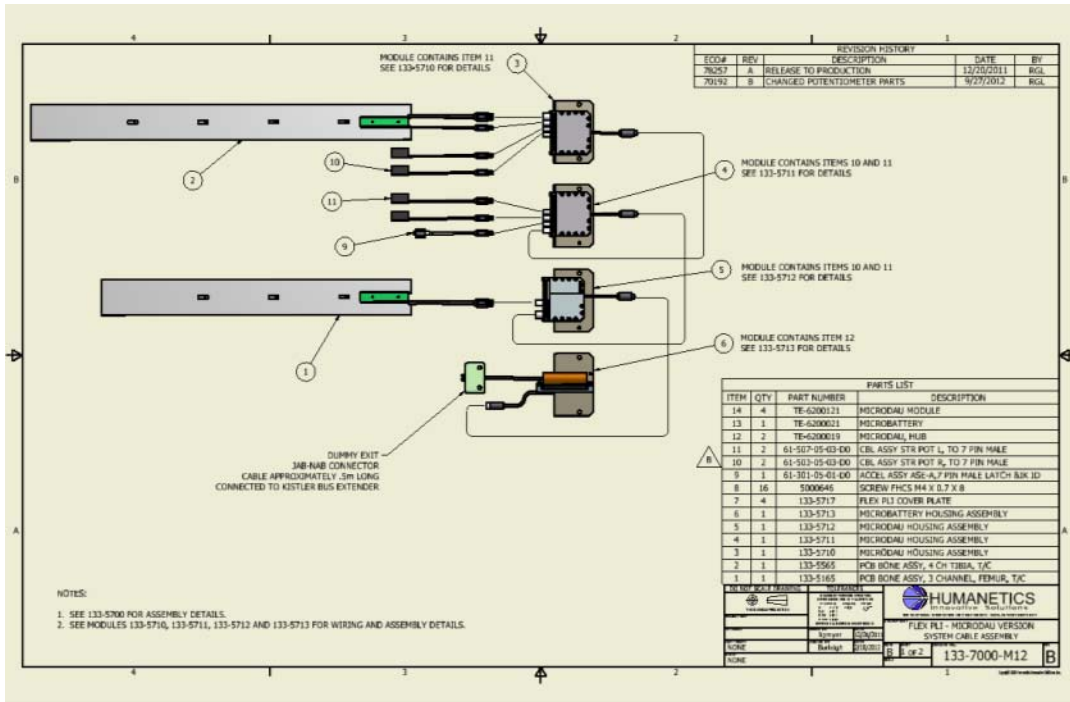

Figure 42 . Showing drawing of Micro Dau part numbers

The battery module also provides the leg exit cable. This cable is configured with a magnetic breakaway connector assembly. Magnets are configured such that electrical contact is solidly made while preventing unwanted misalignment. The connector is specifically designed for easy and safe disconnect to prevent cable, sensor or data acquisition system damage.



Figure 43 . Right hand side of impact face, lower covers removed



Figure 44 . Left hand side of impact face, covers fitted

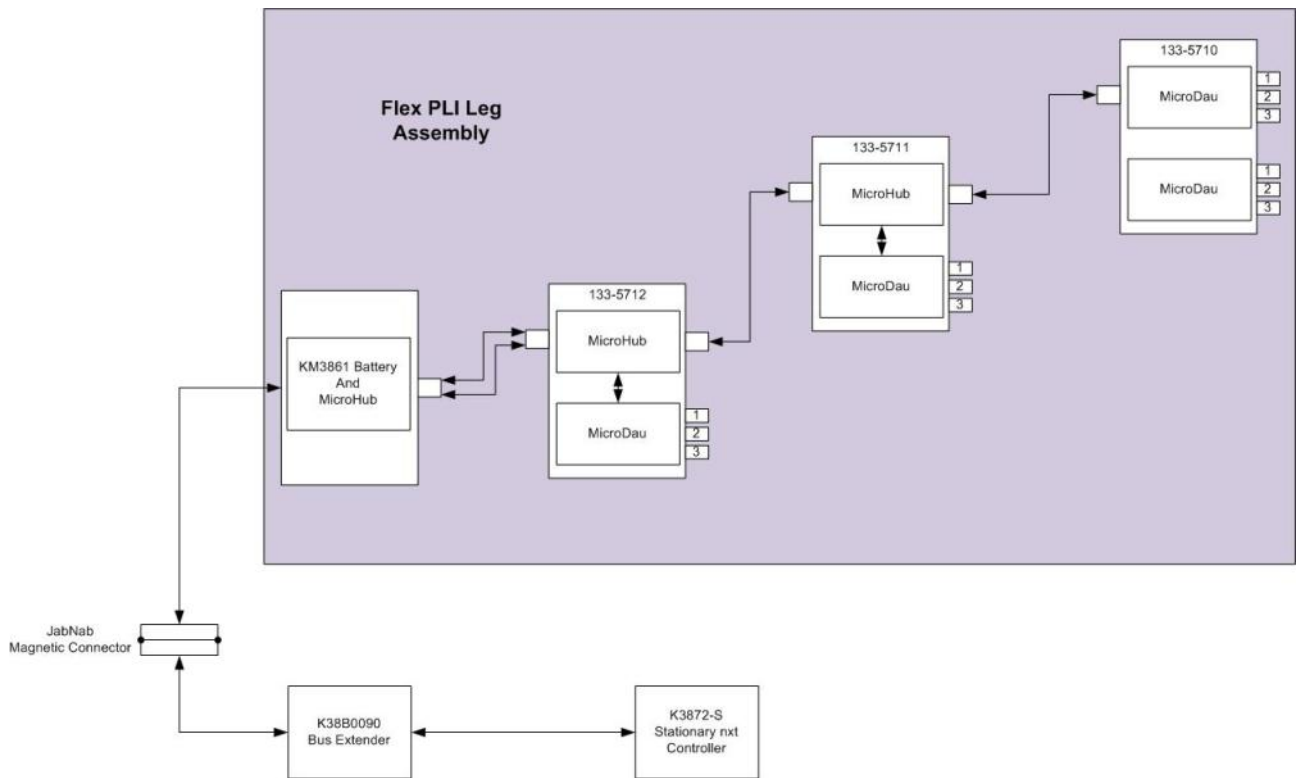

Figure 45 . Schematic layout of 12 channel Micro Dau

Section 3. Assembly and Disassembly

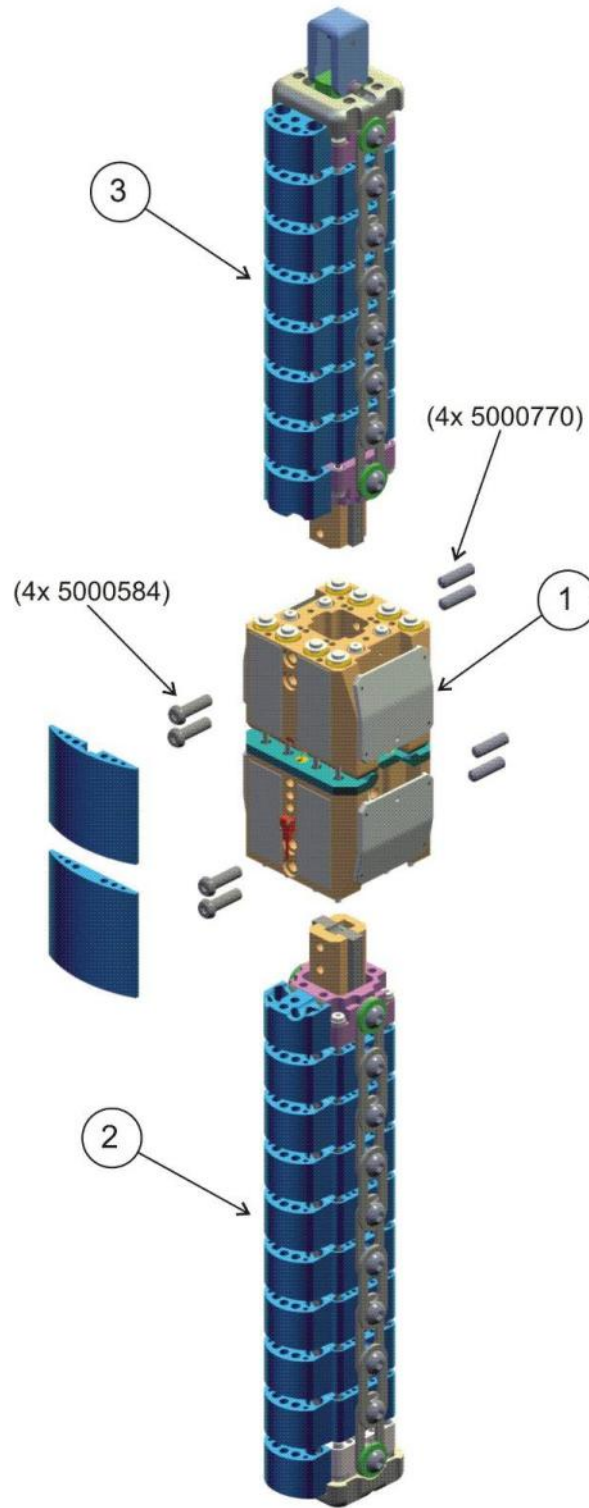

Figure 46 . Leg assembly, Exploded View

ITEM	QTY	PART NO.	DESCRIPTION
1	1	133-5300	KNEE ASSEMBLY, FLEX PLI
2	1	133-5500	TIBIA ASSEMBLY, FLEX PLI
3	1	133-5100	FEMUR ASSEMBLY, FLEX PLI
4	1	133-5020	BUFFER SHEET ASSEMBLY, LEG (NOT SHOWN)
5	1	133-5013	COVER, INNER, FEMUR (NOT SHOWN)
6	1	133-5014	COVER, OUTER, FEMUR (NOT SHOWN)
7	1	133-5015	COVER, INNER, TIBIA (NOT SHOWN)
8	1	133-5016	COVER, OUTER, TIBIA (NOT SHOWN)
9	1	133-5017	COVER, FLEX PLI GTR (NOT SHOWN)
10	6	133-5019	VELCRO BUNDLE TIE, 500mm LONG (NOT SHOWN)

Table 6. Flex PLI Parts List

3.1 Femur Exploded View

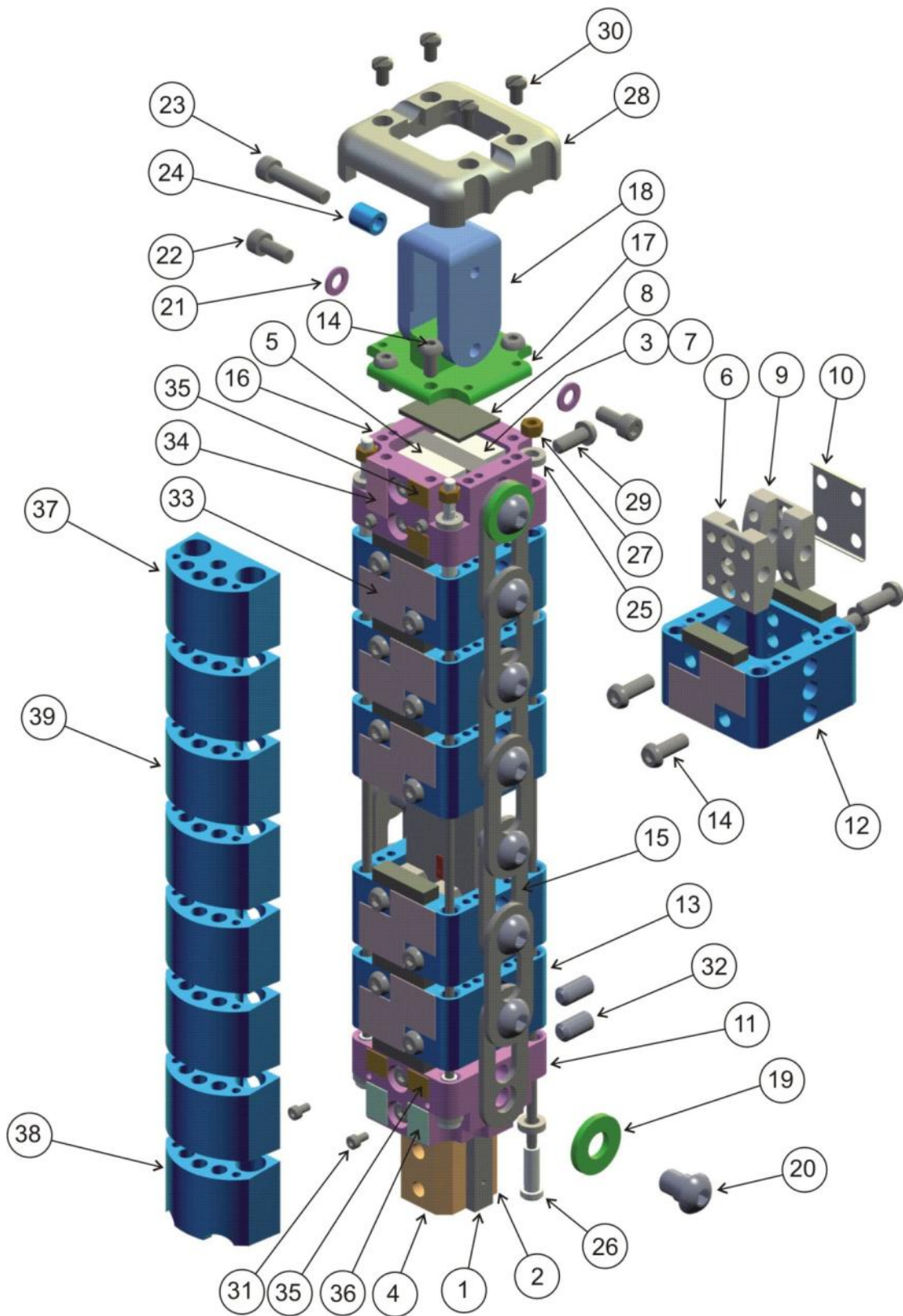

Figure 47 . Femur Assembly, Exploded View

ITEM	QTY	PART NO.	DESCRIPTION
1	1	133-5165	FEMUR BONE ASSEMBLY TESTED & CERTIFIED
2	1	133-5508	BONE CLAMP THIN, KNEE
3	1	133-5503	BONE CLAMP THIN, FEMUR/TIBIA
4	1	133-5506	BONE CLAMP THICK, KNEE
5	1	133-5502	BONE CLAMP THICK, FEMUR/TIBIA
6	5	133-5505	SPACER, BONE CONTACT, THICK
7	1	133-5504	SHIM, BONE CLAMP (.4 THICK) OPTIONAL
8	1	133-5510	RUBBER BUFFER, FEMUR/TIBIA END
9	5	133-5507	SPACER, BONE CONTACT, THIN
10	5	133-5509	SHIM (0.4 THICK) OPTIONAL
11	1	133-5514	INNER SEGMENT, KNEE
12	5	133-5534	INNER SEGMENT ASSEMBLY
13	1	133-5535	INNER SEGMENT ASSEMBLY CLOSES TO KNEE
14	28	5000465	SCREW, BHCS M6 X 1 X 18
15	14	133-5515	LINK
16	1	133-5108	SEGMENT TOP, FEMUR
17	1	133-5102	PLATE, TOP
18	1	133-5103	LAUNCH GUIDE
19	4	133-5104	WASHER, 12 ID X 26 OD X 3
20	16	133-5106	SHOULDER BOLT
21	2	5000094	WASHER, FLAT M6 (6.7 ID X 12.5 OD X 1.0 THK.)
22	2	5000604	SCREW, SHCS M6 X 1 X 14
23	1	5000008	SCREW, SHCS M6 X 1 X 30
24	1	133-5107	ROLLER
25	8	133-5521	WASHER, CABLE
26	4	133-5110	CABLE ASSEMBLY, FEMUR
27	4	5000522	HEX NUT, M5 X 0.8 NYLOK
28	1	133-5516	END COVER
29	6	5000072	SCREW, BHCS M6 X 1 X 16
30	4	5000814	SCREW BHCS, M5 X .8 X 8
31	4	5000393	SCREW, SHCS M3 X .5 X 6
32	2	5000769	SCREW, MSSFP M8 X 16
33	6	133-5025	TAPE, IMPACT SEGMENT
34	1	133-5028	TAPE, END COVER, 12 X 24
35	4	133-5027	TAPE, END COVER, 10 X 12
36	2	133-5026	TAPE, END COVER, 12 X 16
37	1	133-5518	COVER, END IMPACT
38	1	133-5519	COVER, END IMPACT, (KNEE END)
39	6	133-5517	IMPACT SEGMENT
40	5	133-5001	SHIM, (T0-5) OPTIONAL (NOT SHOWN)
41	2	133-5002	SHIM, BONE CLAMP (T0-05) OPTIONAL (NOT SHOWN)
42	2	133-5003	SHIM, BONE CLAMP (T0-5) OPTIONAL (NOT SHOWN)
43	2	133-5004	SHIM, BONE CLAMP (T0-6) OPTIONAL (NOT SHOWN)
44	5	133-5005	SHIM (T0-6) OPTIONAL (NOT SHOWN)
45	15	133-5012	SHIM, (.05) OPTIONAL (NOT SHOWN)

Table 7. Femur Assembly, Parts List

3.1.1. Femur (Upper Leg) Assembly

Before assembly check all rubber buffers are bonded to segments. In the unlikely event a buffer should become dislodged, damaged or lost it will need re-bonding. When bonding the segment buffers ensure surfaces of both parts are prepped before bonding, prepare plastic with 240 grit paper and rubber with 80 grit, degrease then bond with Loctite 401 or similar.

When handling the bone core it is recommended that gloves are worn to prevent getting splinters in the hand. Do not run your hand along the bone without protection.

Start the assembly from the knee end of the bone. The insert leg pivot 133-8129 from the static calibration fixture will be required for assembly as this will allow the bone to be assembled flush with the end clamps, make assembly stable when building and simplify segment assembly.

Fit bone clamp 133-5506 inside the fixture base 133-8129 with curved end upwards and groove side inwards, loosely fix with 2x M8 x 20 screws. Fit the inner segment knee 133-5514 over the clamp and attach finger tight with 2x M6 x 16 BHCS. See Figure 48.

Place 133-5508 over the bone PCB curved end up and insert bone and clamp into the base see Figure 49. The PCB is on the rear of the leg (non impact side).

Fit 2x M8 x 12 SSFP (Socket Set Flat Point) screw into the fixture base then the 2x M8 x 16 SSFP into 133-5514 segment. Tighten all the screws to 3 Nm.

Lay the PCB exit wire to the side required for the specific DAS wiring requirement. If the knee assembly is to hand you will be able to check the DAS as to which side this needs to go.

Fit 133-5505 (spacer bone contact thick) to segment 133-5535 (blue segment with rubber buffers both sides) using 2x M6 x 18 zinc plated BHCS (Button head cap screw). Fit screws diagonally then slide over the bone with the thick spacer on the impact side. Take care not to damage the black strain gage cover running down the centre of the bone. The difference in thickness between the rear thin curved spacers and the front impact thick curved spacers is 0.5mm (12.25 thin and 12.75mm thick). The thinner spacer allows for the shim thickness.

The bone segments should have been laid out in the order they were disassembled, this should help reassembly, if not the process will still be the same. If the leg has seen a number of tests some wear may have taken place and a different shim configuration would be required to ensure the bone is rebuilt with as tight a segment fit as possible. This tight fit allows for wear in future testing and will help keep the leg certified.

Using the previous shim arrangement with its internal flat shims inside the captive shim see Figure 60, locate against the spacer bone contact thin (133-5507) see Figure 51 and push this assembly centrally into the gap against the bone. **Note: When fitting the shim assembly use thumb force only, pushing down on the top of the spacer. Do not hammer shims into place.** You should feel high resistance when pushing this assembly in. You can check the fit by rotating the segment on the bone Z axis. If there is any play remove and add a 0.05 mm (133-5012), 0.1 mm (133-5029) or 0.2 mm (133-5030) flat shim inside the captive shim or any combination of these to get a tight fit. When the spacer assembly does not fit usually you only need to remove a 0.05 shim and that will be as tight as you can achieve. When fit is as tight as possible with thumb pressure ensure screw holes are aligned then fix the shim assembly with 2x M6 x 18 BHCS fitted diagonally and tighten front and rear screws to 3 Nm. Use the set screw key if needed to align the holes if not aligned by inserting into the hole and levering the inner assembly into position.

For the next segment assembly attach a spacer bone contact thick to the blue segment part 133-5534 using 2x M6 x 18 zinc plated BHCS fitted diagonally as per the previous segment. Slide over the bone with rubber buffers on top side and spacer to the front impact side. Try fitting the same rear shim arrangement as the previous shim assembly. Adjust shims if still loose; remove a 0.05 shim if the

assembly cannot be pushed into the segment. Align holes to the segment and fit the two rear M6 x 18 BHCS diagonally and torque all 4x M6 screws front and rear to 3 Nm.

Repeat for the next 3 segments.

For the last 2 segments fit 133-5502 (Bone clamp thick) to the last blue segment and to 133-5108 (Segment top femur) using 2x M6 x 18 BHCS for the blue segment and 2x M6 x 16 for the top aluminium segment.

Replace the previous large shim (shim bone clamp) that went over the clamp 133-5503 (Bone clamp thin) and fix into the aluminium segment 133-5108 using 2x M6 x 16 BHCS. Also fit the 2x M6 x 18 BHCS through the back of the blue segment and tighten. Slide or push these two segments over the top of the bone. If the fit is loose, over either of the segments add more 0.05 shims until the fit is tight. A higher push force will probably be needed for this fit as the inner dimension of the two segments may not be perfectly identical, placing the leg on the ground and holding with long M10 bolts located in the link shoulder bolt threads will help stability if needed. Once the fit is tight, tighten all the screws to 3 Nm. Check the distance between the top of the bone and the top of the aluminium segment. This should be between 1.5 and 2 mm and should match the small rubber buffer glued to the underside of the stainless steel top plate. This buffer removes any end play on the bone. On initial assembly this buffer may have been padded out to prevent bone end play. It is important no end play is present. Fit the top plate with 4x M6 x 18 BHCS.

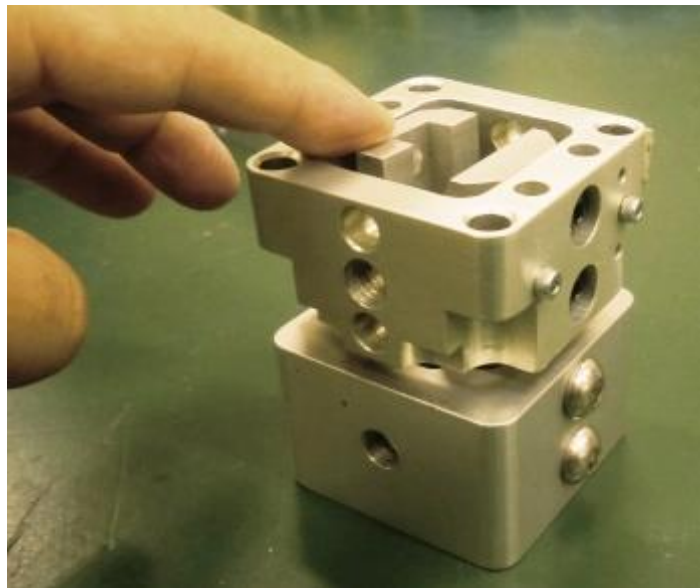

Figure 48 . 133-8129 base with 133-5514 segment and bone clamps inside



Figure 49 . 133-8129 base with 133-5514 segment, bone clamps and bone assembly



Figure 50 . Fitting and tightening first blue segment

Pass the connector through a side link 133-5515 and fit all the links starting from the knee end and 4x end washers using the aluminium shoulder bolts as shown on assembly Figure 47 both sides. The segments may need adjusting slightly to fit the shoulder bolts. Torque all shoulder bolts to 3 Nm. Note some links will need to be removed later for static certification. Starting from the knee end with the links should pull segments to correct leg length and avoid further adjustment.



Figure 51 . Fitting thin bone spacer with captive shim

Place washer (133-5521) over each of the four stainless steel cables (133-5110) and from the knee end, feed through the corner holes in the leg segments. Place washer (133-5521) over threaded fitting and fit four M5 Nyloc nuts. Set the gap between nut and washer to 9.1mm. Check with spacer tool 133-5112. Humanetics recommends the Nyloc nuts should only be used twice after first removal. If the double sided tape is not already fitted degrease all the front segments and fit the 6x double sided tape profiles (133-5025) to the plastic segments then fit all the impact segments (133-5517) locating over two BHCS. When handling parts with tape try to avoid touching it as this will extend its life. If the tape loses its stickiness or gets folded over replace with new.

Fit the 4x M3 x 8 SHCS if not already fitted to the front of the two end aluminium end segments.

Degrease the front of the segments and fit the small double sided tape parts if not already fitted as shown in exploded view Figure 47. Fit the two end impact covers 133-5518 and 133-5519.

Where the bone wire comes out through the link, tie on two cable ties one on the link and one on wire attached to each other as shown in Figure 52 to provide restraint to the wire. The femur must be certified before full leg assembly. Remove the base 133-8129 if not being directly calibrated after build.

Note: a few of the links, washers and shoulder screws will need to be removed and replaced to fit onto the static certification fixture 133-8120. Keep parts together ready for final assembly.



Figure 52 . Bone exit cable restraint use cable ties (ties not shown trimmed or tightened)

3.1.2. Femur assembly after static certification

Fit removed links and shoulder bolts. After pendulum test fit launch guide and roller as shown in exploded view. Fit end cover (133-5516) with 4x M5 x 8 screws. Also fit any optional sensors and mounts if not already fitted.

3.1.3. Femur Disassembly

Disassembly is the reverse of the assembly starting from the top of the femur. Care must be observed when removing bone spaces and shims not to damage bone wires and gages. The double sided tape can be reused if still sticky and if it is not folded over. It will also be important to check for any damaged parts that would need replacement, see section 4. When removing the segments it would be wise to lay them out in order or number their position so that segments, spacers and shims can go back to the same position. This is not critical but is recommended by Humanetics.

3.2 Knee Exploded View

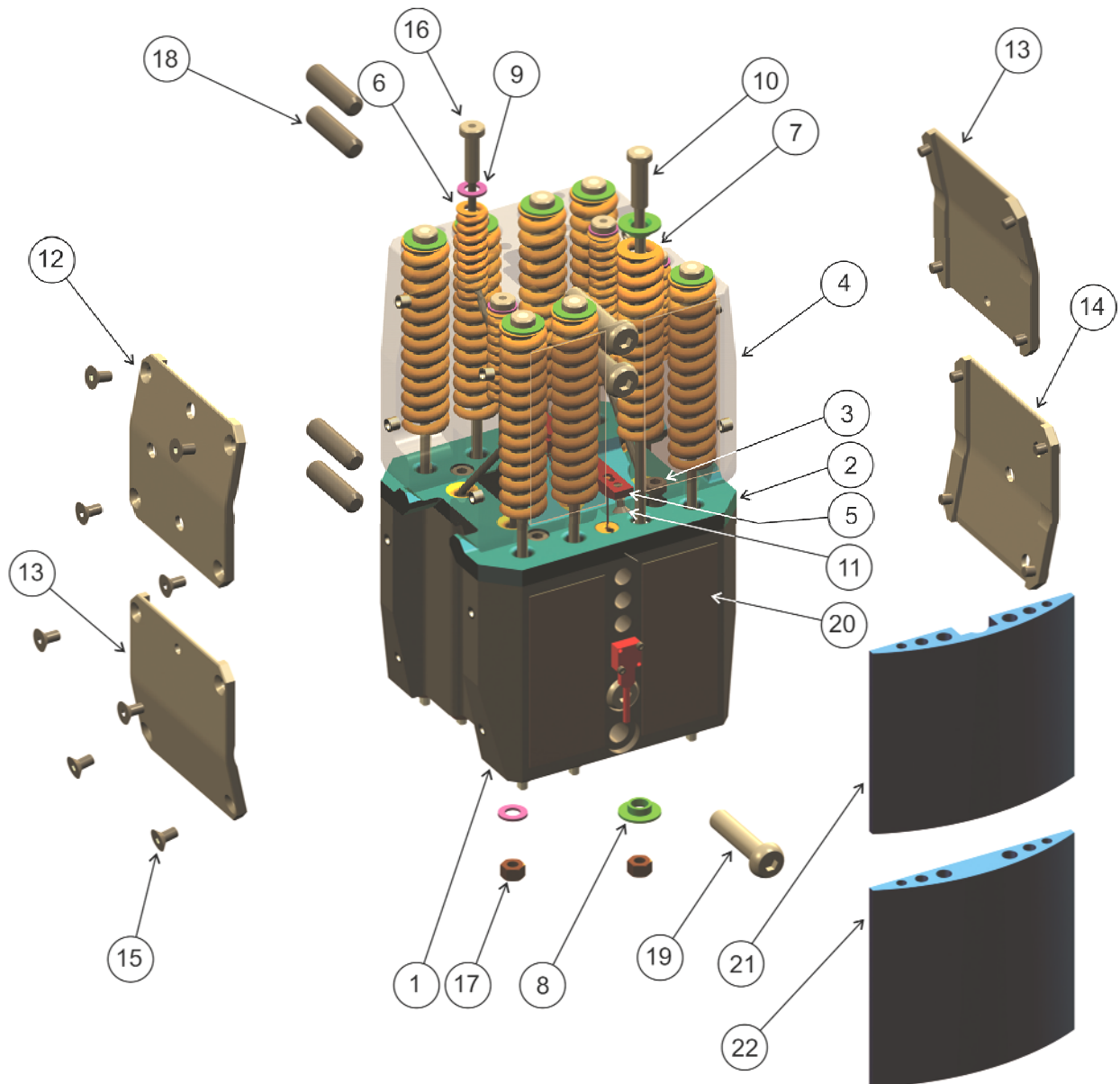

Figure 53 . Knee Assembly, Exploded View

ITEM	QTY	PART NO.	DESCRIPTION
1	1	133-5330	KNEE BLOCK, TIBIA, FLEX PLI
2	1	133-5313	MENISCUS ASSEMBLY
3	4	5000774	SCREW, SHCS M5 X .8 X 10, LOWHEAD
4	1	133-5320	KNEE BLOCK, FEMUR
5	1	133-5302	ATTACHMENT PLATE, STRING POT
6	8	9003159	SPRING, 12 X 40 (AMISTAR DB 12 x 40)
7	16	9003158	SPRING, 18 X 80 (AMISTAR DB 18 x 80)
8	16	133-5310	SPRING CAP
9	8	133-5311	CABLE WASHER
10	8	133-5350	CABLE ASSEMBLY, KNEE ML

11	2	5000203	SCREW, FHCS M3 X 0.5 X 10
12	1	133-5315	COVER, KNEE, FEMUR RIGHT SIDE
13	2	133-5306	COVER, KNEE
14	1	133-5314	COVER, KNEE, TIBIA LEFT SIDE
15	16	5000844	SCREW, FHCS M4 X 0.7 X 8, ZINC
16	4	133-5360	AP CABLE ASSEMBLY
17	12	5000522	HEX NUT, M5 X 0.8 NYLOK
18	4	5000770	SCREW, MSSFP M8 X 30
19	4	5000850	SCREW, BHCS M8 X 1.25 X 35, ZINC
20	4	133-5018	TAPE, FRONT COVER
21	1	133-5304	COVER, UPPER KNEE, FLEX PLI
22	1	133-5305	COVER, LOWER KNEE, FLEX PLI

Table 8. Knee Assembly, Parts List

3.2.1. Knee Assembly

Make a note of the string pot serial numbers and their ligament positions this is needed for DAS identification for sensitivity input. Also see paragraph 4.8.3 for string pot check.

Referring to Meniscus assembly (133-5313) feed the connector of one of the right hand (RH) pull string pots through the inner side of one of the central holes, see Figure 54. The RH and the LH string pots can be identified from the serial number; the RH has an R at the end of the number and the LH an L. The two RH pull string pots are positioned closest to the main flange of the meniscus, one is shown fitted in Figure 54. Attach the string pot with the #2-56 x ¼ long cap head screws making sure the pull wire is directed towards the furthest away outer bronze bush. Fit the other RH pull string pot in the same way on the opposite side. Pass the pull wires through their designated bushes see figure 55. Carry out the same procedure with the Left hand pull string pots, the pull wires are directly in line with the two inner bushes. Feed the pull wires through the bushes. Make sure electrical wires are inside the cavity as much as possible then run cables through channels both sides and clamp with retaining plate see Figure 56. Fit assembly to knee block bottom ensuring pot wires are in their grooves. The threads of the four M5x10 low head cap screws used to retain the meniscus will need to have low strength thread lock applied (e.g. loctite 222). This will prevent the screws coming lose when in service.

If the Messring on board DAS system is to be installed a terminator has to be fitted at this stage. For details of onboard DAS installation see Section 2.

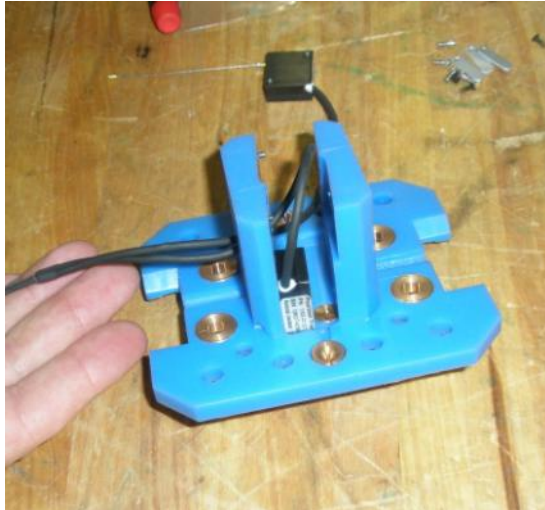

Figure 54 . Meniscus string pot assembly wire feed

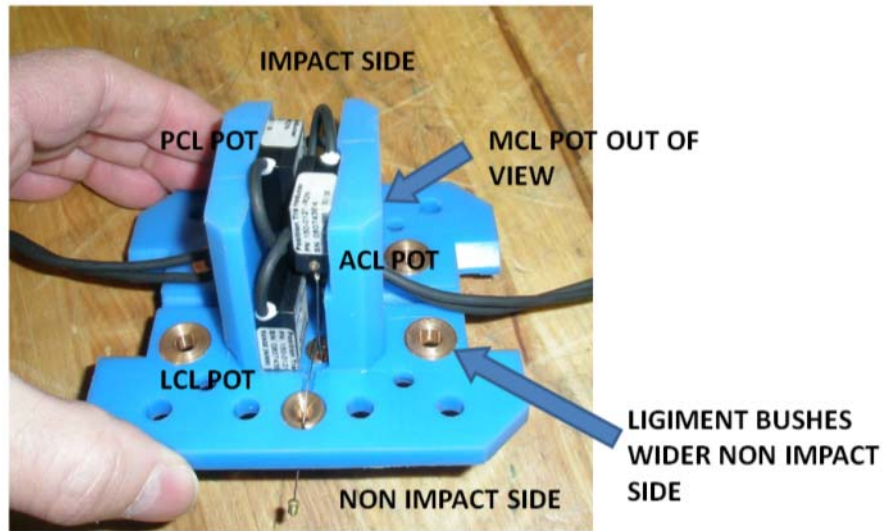

Figure 55 . Meniscus with all string pots assembled. String pots identified

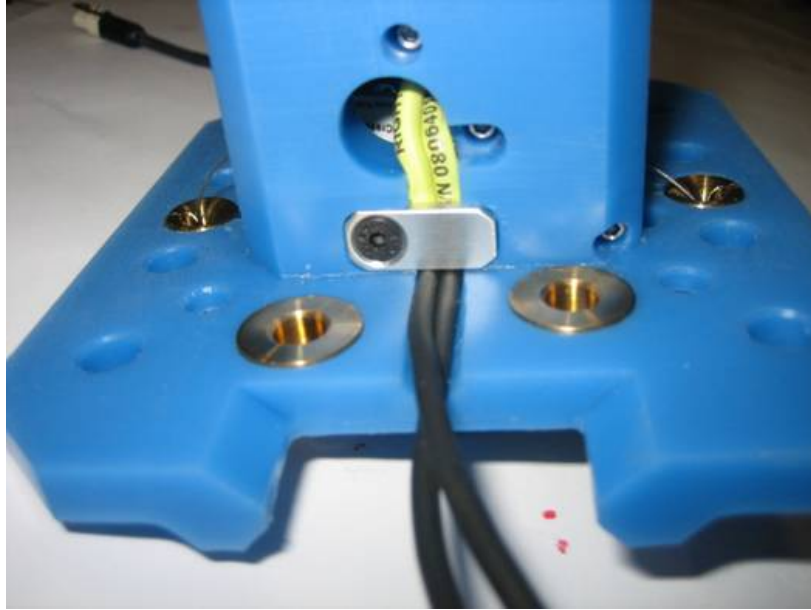

Figure 56 . Meniscus wire clamp

Pass all four ball crimps through attachment plate (133-5302) and place two spacers below it, the pot wires will then be in tension see Figure 57. Two tubular plastic spacers are shown in the photo to show setup clearly, there are special spacers in the tool kit for this purpose 133-5113.

Place four of the $\text{\O}12 \times 40$ long springs (9003159) into the knee block femur and place washer (133-5311) on top of springs; insert wires (133-5360) through springs. Lower this block assembly carefully over the tibia knee block guiding the wires across to their designated holes and locating over the attachment plate see Figure 58. Double check the knee femur block is the right way round, ref exploded view figure 53, and the wires are in their correct aligned holes and not crossed over. Carefully turn the whole assembly over and locate the remaining $\text{\O}12$ springs over the wires. Fit all four washers and Nyloc nuts; tighten nuts down until the washers are exactly flush with the Femur block. Two wrenches 8mm and 1/8" are required to tighten nuts. Humanetics recommends that the Nyloc nuts are only used twice after first disassembly, after that new nuts should be fitted. Fix the attachment plate with 2x M3x8 countersunk screws. Place eight $\text{\O}18$ springs into the femur block counter bores and place washer (133-5310) on top, feed through the 8 wires (133-5350). Turn knee over and fit remaining 8 springs into their counter bores, fit washers (133-5311) and M5 Nyloc nuts, tighten until washers are flush with Tibia block, this can be checked with a flat edge. As a double check the spring protrusion on the Femur block should be 3mm. In this condition the knee is now ready for certification. Keep remaining parts together for final assembly.

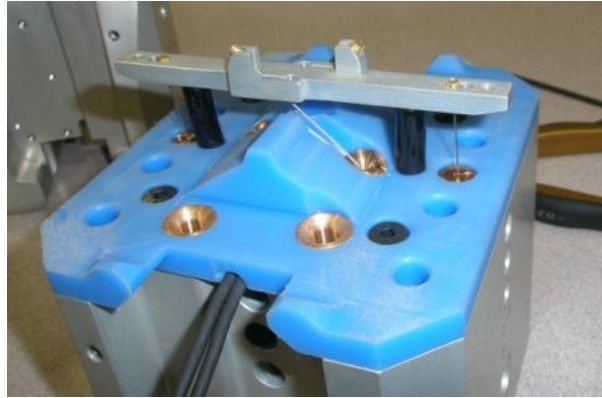

Figure 57 . Attachment plate, crimp wires in tension ready for knee femur block assembly



Figure 58 . Cross wire feed through on knee

3.2.2. Assembly After Certification

The remaining parts are fitted at the final leg assembly stage see 3.3.4. These are single channel accelerometer to impact side of tibia block. The front tape, blue impact covers and the side covers.

3.2.3. Knee Disassembly

Remove aluminum side and front blue plastic covers if these have not already been removed to disassemble leg bones. See section 3.3.4 for details.

Take off the accelerometer if not already removed then remove the 8 large springs from each end by unscrewing the eight M5 Nyloc nuts on one end of the wires. Hold the wire on its end with a 1/8" open ended wrench to allow this.

Before removing the small cross ligament springs the attachment plate holding the string pot wires must be unscrewed otherwise string pots could be damaged when the two knee blocks are pulled apart.

Remove the two M3 flat head screws fixing the attachment plate to the femur block.

Now unscrew the four M5 Nyloc nuts holding the central cross wires and remove the four smaller springs from the tibia block.

Lift the femur block away from the tibia block. The fitting on the end of the cross wire can catch on the hole in the counter bore so the cables may require some realignment to free them. Remove the wires and

smaller springs from the femur block. On the tibia block disconnect the crimped ends of the spring pots from the attachment plate and remove attachment plate.

To remove the meniscus for access to spring pots remove the four M5 low head cap screws and pull it away from the tibia block. These should have been loctited in so may be stiff. If the string pots need servicing remove wire retaining clamps and unscrew the #2-56 cap screws fixing the pots.

Check all parts for damage and replace if necessary. Take note to check there has been no slippage on the crimps on the string pot mechanical wires. The left hand and right hand pull wires should both be 61.5 mm from the stop at the potentiometer to the start of the ball fitting see figure 70. It is recommended that the Knee assembly is re-certified after reassembly.

3.3 Tibia Exploded View

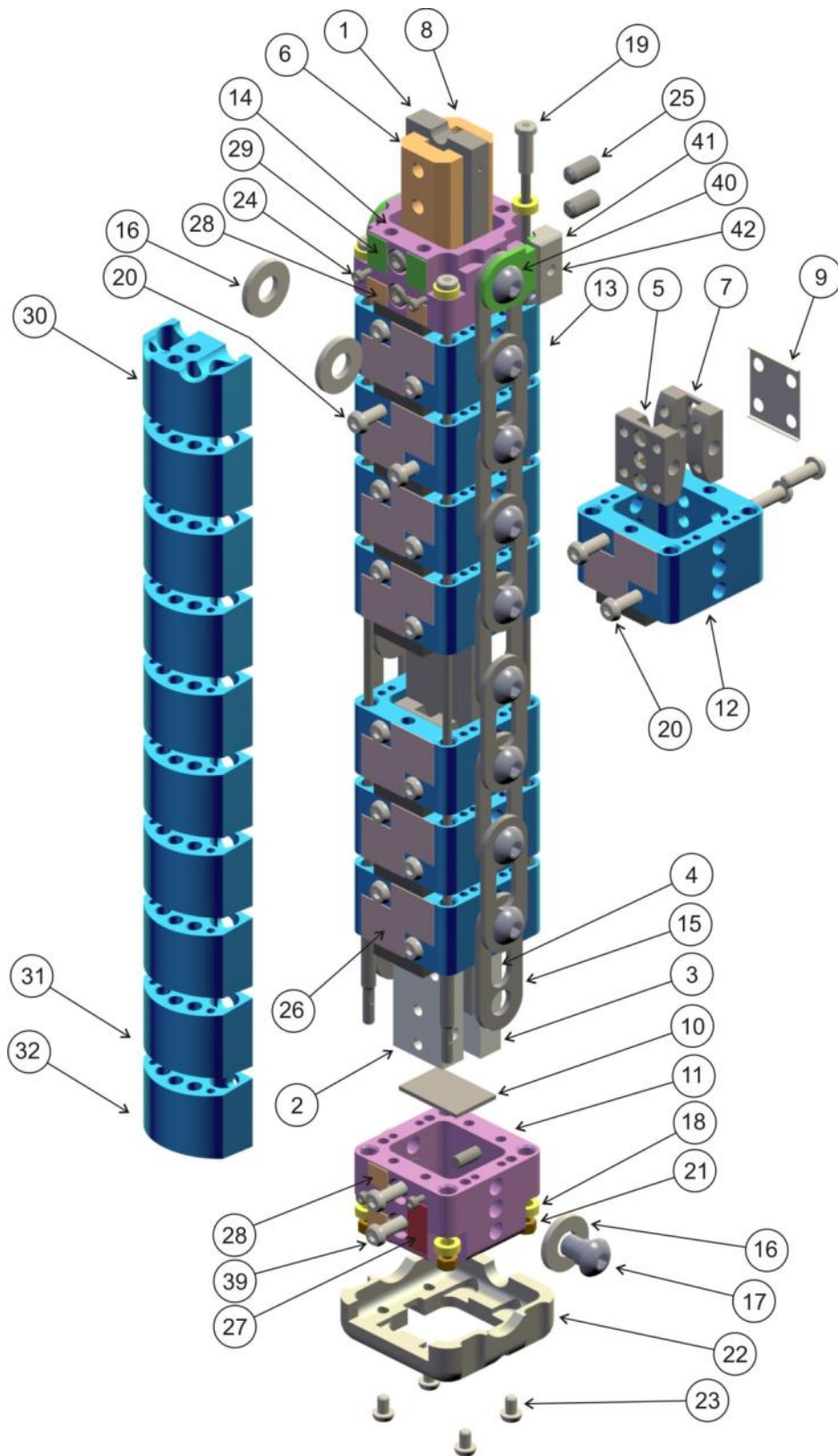

Figure 59 . Tibia Assembly, Exploded View

ITEM	QTY	PART NO.	DESCRIPTION
1	1	133-5565	TIBIA BONE ASSEMBLY TESTED & CERTIFIED
2	1	133-5502	BONE CLAMP THICK, FEMUR/TIBIA
3	1	133-5503	BONE CLAMP THIN, FEMUR/TIBIA
4	1	133-5504	SHIM, BONE CLAMP (.4 THICK)
5	7	133-5505	SPACER, BONE CONTACT, THICK
6	1	133-5506	BONE CLAMP THICK, KNEE
7	7	133-5507	SPACER, BONE CONTACT, THIN
8	1	133-5508	BONE CLAMP THIN, KNEE
9	7	133-5509	SHIM (0.4 THICK)
10	1	133-5510	RUBBER BUFFER, FEMUR/TIBIA END
11	1	133-5511	SEGMENT BOTTOM, TIBIA
12	7	133-5534	INNER SEGMENT ASSEMBLY
13	1	133-5535	INNER SEGMENT ASSEMBLY CLOSES TO KNEE
14	1	133-5514	INNER SEGMENT, KNEE
15	18	133-5515	LINK
16	4	133-5104	WASHER, 12 ID X 26 OD X 3
17	20	133-5106	SHOULDER BOLT
18	8	133-5521	WASHER, CABLE
19	4	133-5530	CABLE ASSEMBLY, TIBIA
20	32	5000465	SCREW, BHCS M6 X 1 X 18
21	4	5000522	HEX NUT, M5 X 0.8 NYLOK
22	1	133-5516	END COVER
23	4	5000814	SCREW, BHCS M5 X 0.8 X 8
24	4	5000393	SCREW, SHCS M3 X .5 X 6
25	2	5000769	SCREW, MSSFP M8 X 16
26	8	133-5025	TAPE, IMPACT SEGMENT
27	1	133-5028	TAPE, END COVER, 12 X 24
28	4	133-5027	TAPE, END COVER, 10 X 12
29	2	133-5026	TAPE, END COVER, 12 X 16
30	1	133-5519	COVER, END IMPACT, (KNEE END)
31	8	133-5517	IMPACT SEGMENT
32	1	133-5518	COVER, END IMPACT
33	7	133-5001	SHIM, (T0-5) OPTIONAL (NOT SHOWN)
34	2	133-5002	SHIM, BONE CLAMP (T0-05) OPTIONAL (NOT SHOWN)
35	2	133-5003	SHIM, BONE CLAMP (T0-5) OPTIONAL (NOT SHOWN)
36	2	133-5004	SHIM, BONE CLAMP (T0-6) OPTIONAL (NOT SHOWN)
37	7	133-5005	SHIM (T0-6) OPTIONAL (NOT SHOWN)
38	21	133-5012	SHIM, .05 (OPTIONAL) (NOT SHOWN)
39	6	5000072	SCREW, BHCS M6 X 16
40	2	133-5522	WIRE EXIT BASE
41	2	133-5523	WIRE EXIT CLAMP
42	2	5000654	SCREW, BHCS M5 X .8 X 12

Table 9. Tibia Assembly, Parts List

3.3.1. Tibia Assembly

Before assembly check all rubber buffers are bonded to segments. If for any reason a buffer should become dislodged, lost or damaged it will need replacing or re-bonding. When bonding the buffer ensure surfaces of both parts are prepared before bonding, prepare plastic with 240 grit paper and rubber with 80 grit, degrease then bond with Loctite 401 or similar.

When handling the bone core it is recommended that gloves are worn to prevent getting splinters in the hand. Do not run your hand along the bone without protection.

Start the assembly from the knee end of the bone. The insert leg pivot 133-8129 from the static calibration fixture will be required for assembly as this will allow the bone to be assembled flush with the end clamps, make assembly stable when building and simplify segment assembly. Fit bone clamp thick 133-5506 inside the fixture base 133-8129 with curved end upwards and groove side inwards, Fix finger tight with 2x M8 x 20 screws. Fit the inner segment knee 133-5514 over the clamp and attach finger tight with 2x M6 x 16 BHCS.

Place bone clamp thin 133-5508 over the bone PCB and insert bone and clamp together into the base see Figure 49. The PCB is on the rear of the leg (non impact side).

Fit 2x M8 x 12 SSFP (Socket Set Flat Point) screws into the fixture base then the 2x M8 x 16 SSFP into 133-5514 segment. Tighten all the screws to 3 Nm

Lay the PCB exit wire to the side required for the specific DAS wiring requirement. If the knee assembly is to hand you will be able to check the DAS as to which side this needs to go.

Fit 133-5505 (spacer bone contact thick) to segment 133-5535 (blue segment with rubber buffers both sides) using 2x M6 x 18 zinc plated BHCS. Fit screws diagonally then slide over the bone with the thick spacer on the impact side. Take care not to damage the black strain gage cover running down the centre of the bone. The difference in thickness between the rear thin curved spacers and the front impact thick curved spacers is 0.5mm (12.25 thin and 12.75mm thick). The thinner spacer allows for the shim thickness.

The bone segments should have been laid out in the order they were disassembled, this should help reassembly, if not the process will still be the same. If the leg has seen a number of tests some wear may have taken place and a different shim configuration would be required to ensure the bone is rebuilt with as tight a segment fit as possible. This tight fit allows for wear in future testing and will help keep the leg certified.

Using the previous shim arrangement with its internal flat shims inside the captive shim, see figure 60, locate against the spacer bone contact thin (133-5507) see Figure 51 and push this assembly centrally into the gap against the bone. **When fitting the shim assembly use thumb force only, pushing down on the top of the spacer. Do not hammer shims into place.** You should feel high resistance when pushing this assembly in. You can check the fit by rotating the segment on the bone Z axis. If there is play remove and add a 0.05 mm (133-5012), 0.1 mm (133-5029) or 0.2 mm (133-5030) flat shims inside the inner captive area or any combination of these to get a tight fit. When the spacer assembly does not fit usually you only need to remove a 0.05 shim and that will be as tight as you can achieve. When fit is as tight as possible with thumb pressure ensure screw holes are aligned then fix the shim assembly in the segment with 2x M6 x 18 BHCS fitted diagonally and tighten front and rear screws to 3 Nm. You can use the Allan key to align the holes if not aligned by inserting into the hole and levering the inner assembly into position.

For the next segment assembly attach a spacer bone contact thick to the blue segment part 133-5534 using 2x M6 x 18 zinc plated BHCS fitted diagonally as per the previous segment. Slide over the bone, rubber buffers on top side and spacer to the front impact side. Try fitting the same new shim arrangement as the previous shim assembly. Adjust shims if still loose; remove a 0.05 shim if the assembly cannot be

pushed into the segment. Align holes to the segment and fit the two rear M6 x 18 BHCS diagonally and torque all 4 M6 screws front and rear to 3 Nm.

Repeat for the next 5 segments.

Check inside 133-5511 (Segment bottom tibia) that the rubber buffer is still bonded inside the bottom of the part. If not this will need to be located and re-bonded to prevent bone end play

For the last 2 segments fit 133-5502 (Bone clamp thick) to the last blue segment and to 133-5511 (Segment bottom tibia) using 2x M6 x 18 BHCS for the blue segment and 2x M6 x 16 BHCS for the aluminium segment. Ensure the bone clamp thick is on the impact side.

Replace the previous large shim (shim bone clamp) and any other thinner shims that went over the clamp 133-5503 (Bone clamp thin) and place this assembly inside the two segment assembly, fix to the aluminium segment using 2x M6 x 16 BHCS and 2x M6 x 18 BHCS to the blue segment. See figure 61.

Slide or push these two segments over the top of the bone. Check there is no gap between the bone and the rubber buffer by looking through the holes in the side of the end aluminium segment. If there is this should be packed so that there is no bone end play. If the fit is loose over either of the segments add a 0.05 shim until the fit is tight on both segments. A higher push force will probably be needed for this fit as the inner dimension of the two segments may not be identical, placing the leg on the ground and holding with long M10 side bolts will help stability if needed, see Figure 62. Once fit is tight, tighten all eight screws to 3 Nm.

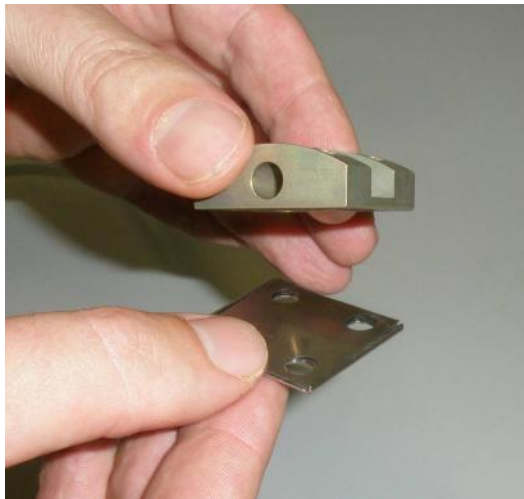

Figure 60 . Typical shim arrangement with .05 shim inside captive shim

Pass the connector through a link 133-5515 then assemble all the links and washers from the knee end with shoulder screws as shown in exploded view both sides. The segments may need adjusting slightly to align holes for shoulder bolts. If off board DAS or Messring DAS is being used fit the wire clamps (133-5522 & 133-5523) under the shoulder bolts closest to the knee see Figure 16. The two washers (133-5104) will have to be removed to fit these clamps. The wire clamps are generally only used for off board wires or Messring DAS disconnect.

Place washer 133-5521 over each stainless steel cable 133-5530 and feed through the 4 corner holes in all the leg segments from the knee end. Place another 133-5521 washer over threaded fitting end and fit four M5 Nyloc nuts. Set the gap between nut and washer to 10.3 mm using 4 and 8mm wrenches. Check gap with spacer tool 133-5112. If the Nyloc nuts are removed Humanetics recommends they are only used twice.

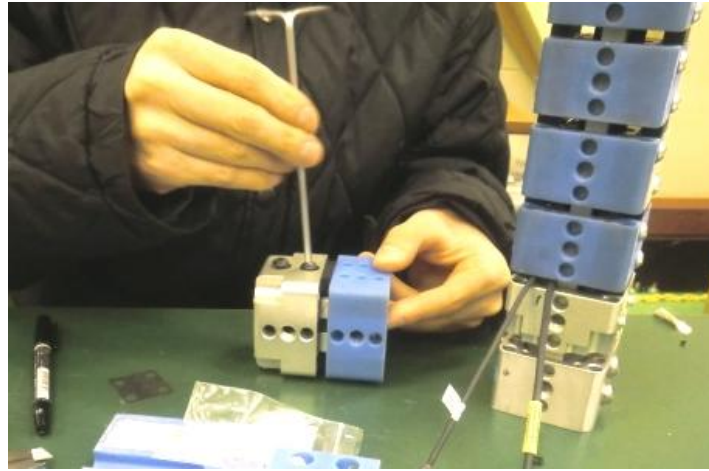

Figure 61 . Assembly of last two segments on tibia



Figure 62 . Fitting last two segments to tibia, applying force using M10 bolts

If fitting new double sided tape, unpeel cover material from the tape on one side (133-5025) and fit over each segment as shown in exploded view figure 59. Fit an impact segment (133-5517) locating over two BHCS and press down onto the tape. Reusing existing tape on segments is OK as long as the tape is flat and still very sticky.

Where the bone wire comes out through the link, tightly tie on two cable ties as shown in Figure 52 to provide restraint to the wire. The assembly is now ready for calibration.

Note: When recalibrating a few of the links, washers and shoulder screws will need to be removed and replaced to allow fitting to the calibration fixture. Keep all parts together ready for final assembly.

3.3.2. After Calibration:

Fit removed links and side shoulder bolts. The end cover (133-5516) should be fitted after pendulum calibration with M5 button head cap screws. Also fit any optional instrumentation.

3.3.3. Tibia Disassembly

Disassembly is the reverse of assembly starting at the bottom of the tibia. Care must be observed when removing bone spaces and shims not to damage bone wires and gages down the center of the bone. The double sided tape can be reused if still sticky and is not folded over. It will also be important to check for any damaged parts that would need replacement, see section 4. When removing the segments it would be wise to lay them out in order or number their position so that segments, spacers and shims can go back to the same position. This is not critical but is recommended by Humanetics.

3.3.4. Leg Assembly

When the leg is not being used or shipped the tight fitting flesh system should be removed to prevent stretching and long term indentation from the leg components.

To access the screws in the knee first step is to carefully prize away the two blue front plastic covers (if assembled). Use a screw driver inside one of the cover lightening holes and gently lever away from the double sided tape attaching it to the knee. Insert the Femur into the knee block femur (133-5320). Fit two M8x35, BHCS into the knee block front counter bored holes and tighten see figure 46. Fit two M8x30 set screws to the rear of the leg and screw in to their stops. Carry out the same fitting for the tibia. All these 8x M8 screws must be tightened to 8 Nm as do the 4x non impact side M8 set screws in the aluminum leg segments see Figure 63 below. Note when tightening the segment screws start with the screw nearest to the knee to avoid the inner spacer levering over inside the segments.

Remove the four side knee covers if fitted, and make wire connections. For off board or on board configurations, wires will require careful routing and securing see section 2. Fit the accelerometer to the front of the knee tibia block and connect wire to DAS. Refit all front and side covers. The disconnect wire will either exit at the top of the leg or just below the knee depending on DAS used. If exiting at the top make sure wire is tied to links and has sufficient play between to allow for the femur to bend and not pull on the wire.

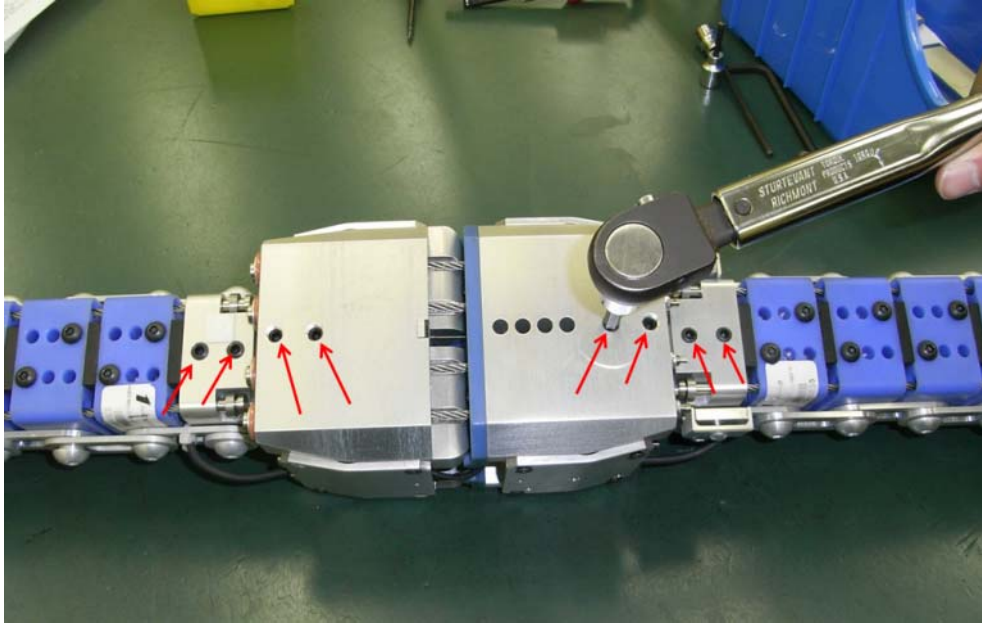

Figure 63 . Screws to be tightened to 8 Nm non impact side

3.3.5. Fitting flesh

On the day of the test or for certification the flesh covers are fitted over the leg. To simplify the fitting of the flesh system all the covers should be laid on the bench in reverse order of assembly. Place the large outer cover on the bench with lettering face down. Lay 6 strips of Velcro tape over with fluffy side down, then place the rubber buffer sheet assembly 133-5020 over the strips. The large rubber part goes to the top of the leg; this is the opposite end to where the zipper on the outer cover starts. Adjust the tape so that all the Velcro strips line up with the six markers on the rubber see figure 64. Lay Thigh 2 and Leg 2 covers over, with the two knee end inside arrows pointing towards each other allowing a gap for the knee area then do the same with Thigh 1 and leg 1 covers. Place the leg assembly onto the laid out flesh covers with thigh (femur) section over thigh covers and leg (tibia) over leg covers with the leg assembly on its side. Fit the black plastic protective end covers to the ends of the leg with 4x M5 BHCS.

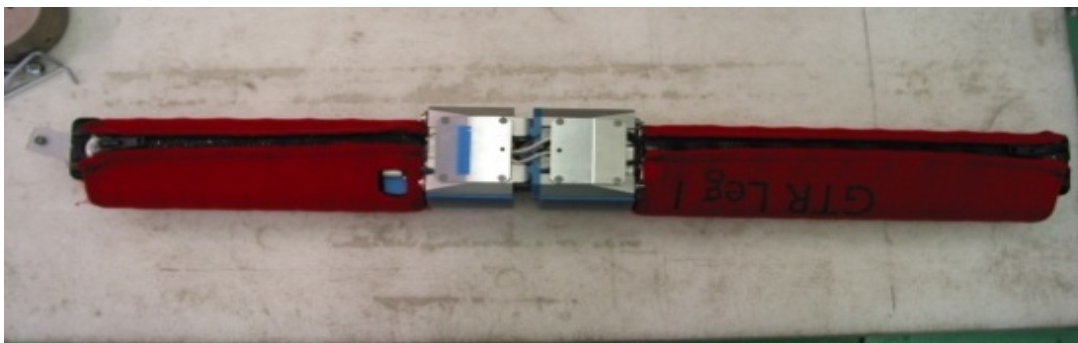

Figure 64 . Assembly of first flesh layer

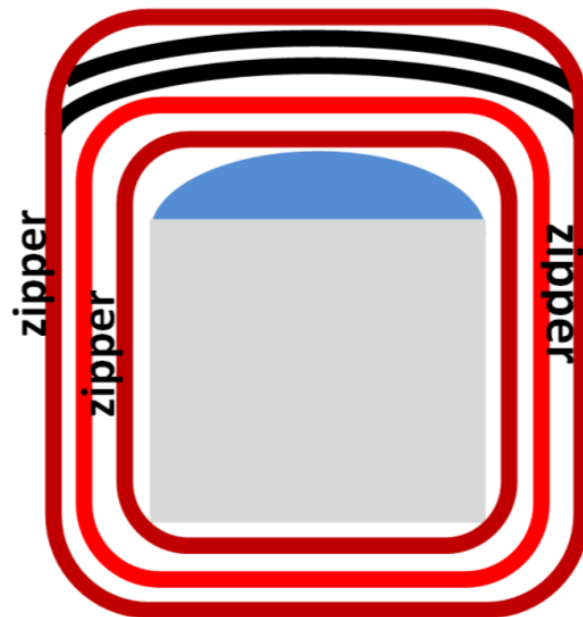

Figure 65 . Zipper locations alternating on the sides (schematic cross section)

Do up the zippers on Thigh 1 and Leg 1 making sure each zipper is positioned on the side of the leg, in the area of the shoulder bolts. Turn the leg over and do up the Thigh 2 and Leg 2 zippers making sure these zippers are on the opposite side to the first. No zipper should be at the back or the front of the leg or it will interfere with the flat surface of the launcher plate or sustain damage due the impact.

Wrap the rubber buffer assembly tightly around the leg using the six Velcro straps. The thick wider part of the rubber system fits just above the top of the femur knee block. See Figure 68, there are markers on the rubber showing the exact position for the Velcro. It is important that the fluffy side of the Velcro is to the outside otherwise the outer cover cannot be stretched over due to grip from the eye side of the Velcro. To get a tight fit with the Velcro it is easier to get someone to pull the rubber sheet around the leg while you are locking the Velcro.

Finally pass any off board wires or disconnect through any holes in the outer cover if applicable and wrap the outer cover around the leg. The outer cover must be zipped up from the bottom of the leg to make zipper fitting easier. If Messring onboard DAS is being used just one wire will exit the leg just below the knee if that position is used. It may be necessary to cut a hole for this wire. Once the zipper is completely zipped up lay the zipper Velcro tag over to protect zipper and to prevent zipper coming undone.

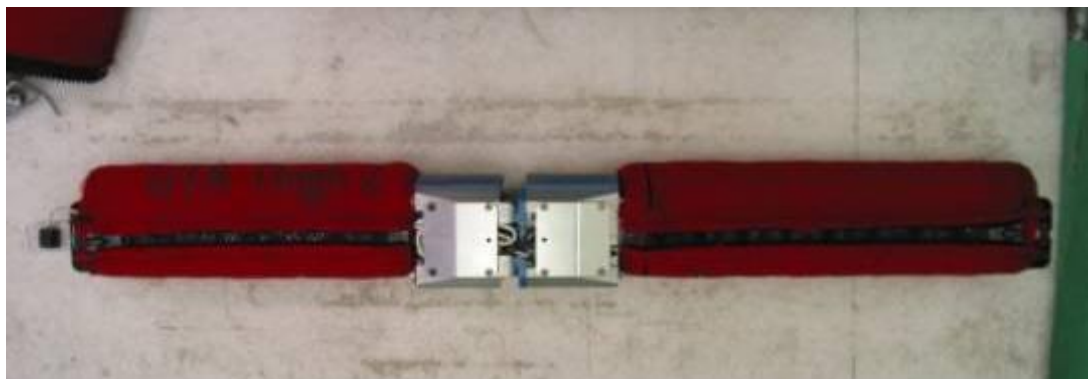

Figure 66 . Assembly of flesh second layer

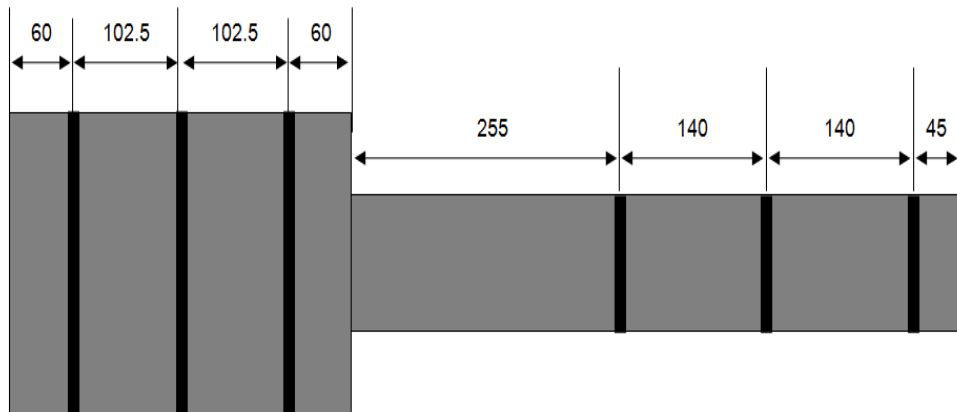

Figure 67 . Rubber flesh assembly Velcro positions

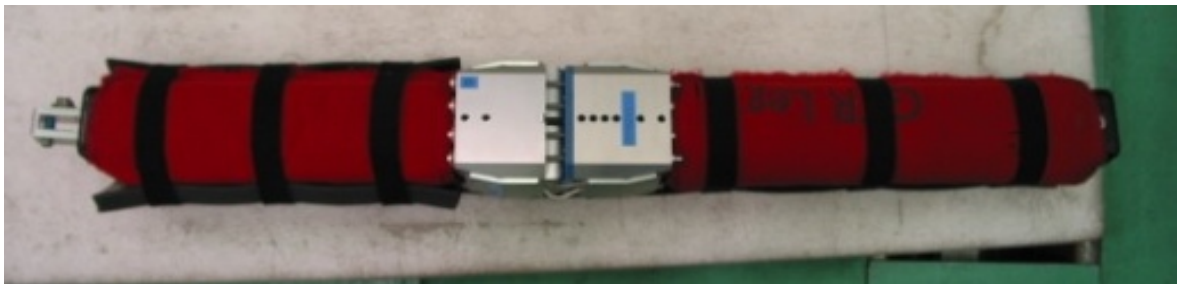

Figure 68 . Rubber flesh tied on with Velcro



Figure 69 . Leg with outer cover fitted

3.3.6. Leg Disassembly

Remove outer cover, flesh rubber and remaining covers. Unclamp off board wires (if fitted) and remove side covers from knee. Disconnect sensor wires as required. Remove front blue covers on knee and remove M8 screws and set screws connecting the femur and tibia to the knee. The leg parts can then be pulled out of the knee.

Section 4. Maintenance

4.1 Introduction

If the leg is passing pendulum or inverse tests that is the main indicator that the leg is suitable to continue testing. If the leg is not passing, this would indicate wear or damage has taken place and the problem needs to be investigated and corrected. Obviously, your first indication of problems would appear with unexpected output of the leg after a vehicle test. Severely exceeding injury criteria may also be a first indication of overloading and would indicate further inspection is necessary. This section aims to give a systematic checking procedure and guidance on when parts require inspection, adjustment, replacement, reassembly or recalibration.

The external visual inspections listed below should be carried out at a minimum after every 10 vehicle tests. The internal inspections should be carried out during every disassembly e.g. when a part has been replaced, during bone re-shimming, during recalibration of sensors or when investigating an internal problem. If the femur, knee or tibia has been reassembled static certification should be carried out along with as a minimum a pendulum certification to ensure the leg is functioning correctly.

4.2 General External Damage inspection

If any parts should become cracked or worn they should be replaced. Examples would be front impact segments or worn side link holes or shoulder screws where the links become very loose.

Double sided tape is used in a number of areas. This can be reused if still sticky and not folded over; otherwise it should always be replaced. All rubber bumpers and rubber flesh sheets should be free of damage.

4.3 Support Roller

Check the blue polymer roller in the top support U bracket at the top of the femur that it is not damaged or worn.

4.4 Red Neoprene Suit Covers

The suit covers, particularly the outer cover is prone to damage as it is the soft contact surface to the vehicle bumper. Small cuts and tears are not a problem, but large tears or zipper damage will require replacement. The zipper maintains the tight fit of the covers and this fit should be maintained.

If the leg is not in use or being transported the covers must always be removed as they will become stretched and indented internally by the legs parts

4.5 Protective Plastic End Covers (Part 133-5516)

These are to protect the ends of the leg when it makes contact with the ground on rebound. These should be durable now metal inserts have been molded into the part. It is advised to take precautions against severe continuous ground impact, for instance by the use of catch ropes or cushioning of the test surroundings. If the leg is likely to be rebounding on the ground after impact, the end covers should be fitted otherwise damage will occur to the end aluminum segments of the leg. The end covers should be replaced if they can no longer be fitted due to damage. (For details on catch rope bracket refer to section 9, vehicle test).

4.6 Tibia and Femur

4.6.1. Assembly Segment Play

With use the bone segments will become loose due to small indentations to the bone and light wear to the curved magnesium interfaces with the bone. If there is concern with the amount of play the tibia or femur assembly should be re-shimmed and statically recertified. See section 6.2. The tibia and femur segments should always be reassembled as tight as possible on any rebuild. There is no specific play limit to when the bone requires re-shimming. If the bone is passing dynamic tests it is OK to use. Should there be significant wear to the curved magnesium interfaces i.e. a prominent flat, these should be replaced but this has not yet been seen in these parts.

4.6.2. Buffers between segments

The two rubber buffers between segments must be in place, central to the axis and bonded to the outer edge of the blue polymer segment. If one should become dislodged or damaged the bone must be disassembled and a new rubber buffer added. See beginning of femur or tibia assembly section 3 for bonding. On reassembly segment shim fit must be as tight as possible.

4.6.3. Shoulder Bolt and Segment Screw Tightness Check

Shoulder bolts and segment screws should be tightened to 3 Nm. This includes the M6 button head segment screws behind the bone front polymer covers as well as the rear M6 screws.

4.7 Knee

4.7.1. Knee Meniscus

The knee meniscus is the blue polymer plate screwed on top of the knee tibia block. This can become worn with use due to contact with the femur knee block. If this wear has created a significant groove in the plastic this could affect free shear motion in the knee and should be replaced. Also if wear has reached the meniscus attachment screws, the meniscus must be replaced.

The bronze cross cable bushes will also wear, this is normal after a large number of tests. It will be more likely the meniscus will wear before these bushes become a problem. These bushes will be new when the meniscus assembly is replaced. All the bronze bushes are pressed in, if one should become loose it must be bonded in or the meniscus replaced. See section 3 of this manual for disassembly and assembly.

4.7.2. Knee spring cables and bone stopper cables

On disassembly it will be noticed that the four knee cross ligament cables will become kinked due to their fixed position. This is normal and as long as the wire filaments are not cut or worn down, the end fittings not pulled away from the cable, and threads are undamaged, they are suitable for reuse. This also applies to the other eight ligament cables in the knee and the four bone stopper cables.

4.8 Sensor and Electrical Maintenance

4.8.1. General Electrical Maintenance

Check electrical cables and connectors for damage and wear. Particularly pay attention to the routing and fixation of the cables in areas with large motion, e.g. around the knee and the point of exit of the cables. Also check that cables have sufficient slack to allow the full range of motion in the knee joint when flexed in testing. Repair broken cables or connectors as necessary.

4.8.2. Bone Maintenance

Warning: There may be tiny glass fibers on the outer surface of the bone that could be irritating to the skin. It is advised to protect the hands with gloves when handling the bone and not to run your hand along the length of the bone. The bone will likely see localized small cracks at the curved interface of the segments after some use. This is normal and may not greatly affect the performance of the bone. If this cracking is severe the bone should be replaced, however if the leg is still passing dynamic certification this would be at the discretion of the user. On reassembly dust off the bone and magnesium segments contact surfaces with a soft brush. At this point, with the bone disassembled also check for wear or damage to electrical components and repair as necessary. The timing for gage calibration is stated in Table 12.

4.8.3. String Potentiometer Maintenance

The timing for sensor recalibration is stated in Table 12. For the string potentiometers check that the pull cables are tight when the knee is assembled and not loose or deformed. If this is the case with injury channels ACL, PCL and MCL, they will need replacing. The LCL is not an injury channel but does give information on the test. So replacement is advised as well. On disassembly of the knee the string crimps should be checked for possible slippage, the dimension from the crimp to the pot is 61.5 mm \pm 1. Also check the spring pull by gently pulling on the pot wires, they should all feel the same. Be careful not to exceed the 38 mm travel. If the pots have not been calibrated for a while it may be worth calibrating while the knee is dismantled. Also check for damage and wear of electrical cables and connectors and repair as necessary.



Figure 70 . String potentiometer pull wire length \pm 1mm

Section 5. Weight Specification

Leg Part	Weight (kg)	Weight Tol (kg)
Femur (133-5100)	2.46	±0.12
Knee (133-5300)	*4.28	±0.21
Tibia (133-5500)	2.64	±0.13
Femur, Knee & Tibia	9.38	±0.47
Flesh System	**3.82	±0.21
Leg Total	13.2	±0.7

Table 10. Flex PLI GTR Mass

*If off board DAS is used knee has 0.1 kg allocated for cables.

** Includes tape and Velcro straps

Description	Mass without Wiring
String Pot (series ISO subminiature)	15g
Kyowa ASE-500-AS7	3g
DTS ARS (optional)	3g
Model 68C Measurement Specialties (optional)	7g
IES 3103 three axis gyro sensor	22g
Model 64 Measurement Specialties (optional)	1g

Table 11. Sensor Mass Breakdown

Section 6. Calibration and certification testing

6.1 Calibration and Certification Overview

Certification of the FLEX-PLI-GTR requires nine different procedures to ensure certified performance of all components. All steps that may be performed by the users are discussed in this section. Calibration of string potentiometers, accelerometer and bending moment strain gauges are not presented in this user manual, as this requires operations only to be carried out by experienced and trained lab personnel. All certification tests shall be conducted in a temperature controlled test environment with a stabilized temperature of 20 ± 2 °C and the temperature shall be recorded. The subsequent steps of certifying the FLEX-PLI-GTR is given in Table 12.

Table 12. FLEX-PLI-GTR certification steps

Step	Description	When Required	Pass-Fail Requirement
0a	Femur Gauge Calibration	1. Annually, recommended	1. $\pm 1.0\%$ linearity full scale 2. $\pm 2.0\%$ hysteresis full scale all gauges
0b	Tibia Gauge Calibration	2. After exceeding injury thresholds for FLEX-GTR in an application test, recommended	
0c	String Potentiometer Calibration	1. Annually	$\pm 1.0\%$ (VRCI-P-100A ¹)
0d	Accelerometer Calibration	1. Annually	1. $\pm 1.0\%$ linearity full scale
1a	Femur Assembly Bending Test	1. Annually recommended	1. Femur centre bending moment-deflection corridor 2. Tibia centre bending moment-deflection corridor
1b	Tibia Assembly Bending Test	2. After exceeding injury thresholds, recommended 3. After maintenance and/or component exchange, recommended	
2	Knee Assembly Bending Test	1. Annually recommended 2. After exceeding injury thresholds, recommended 3. After maintenance and/or component exchange, recommended	1. MCL moment - elongation corridor 2. ACL and PCL moment - elongation corridors
3	Dynamic Pendulum Impact	1. Annually 2. After 10 vehicle tests max 3. After exceeding injury thresholds 4. After maintenance and/or component exchange	1. Peak bending moment tibia 1, tibia 2, tibia 3 and tibia 4 2. peak elongation MCL, PCL and ACL
4	Dynamic Linear Guided Impact	1. Annually 2. After 30 vehicle tests 3. After exceeding injury thresholds 4. After maintenance and/or component exchange	1. Peak bending moment tibia 1, tibia 2, tibia 3 and tibia 4 2. Peak elongation MCL, PCL and ACL

¹ <http://www.veci-vrci.com/VRCI-P-100A.pdf>. 'Industry standard wire wound and non wire wound precision potentiometers'.

6.2 Femur and Tibia Bone Assembly Certification

6.2.1 Introduction

Prior to the femur and tibia assembly certification, the bone cores are tested to established corridors. Each pair of gages on impact side and none impact side (compression and tension) are tested individually to check correct function and establish gage sensitivity at 380 Nm in the loaded direction. It is highly recommended that this operation is carried out by Humanetics. Bone gage sensitivities must be taken from the bone gage calibration sheet provided in the calibration report.

The assembly components are certified to ensure a certified response at component level and to assure passing dynamic certification.

6.2.2 Femur and Tibia assembly Certification

This operation requires the use of a materials testing load frame machine with high definition load cell and calibration fixture 133-8120.

Before testing a 3.2 mm thick Teflon sheet is fixed to a base plate at each end using double sided tape to prevent the sheet sliding on the plate. See pictures below Figure 68.

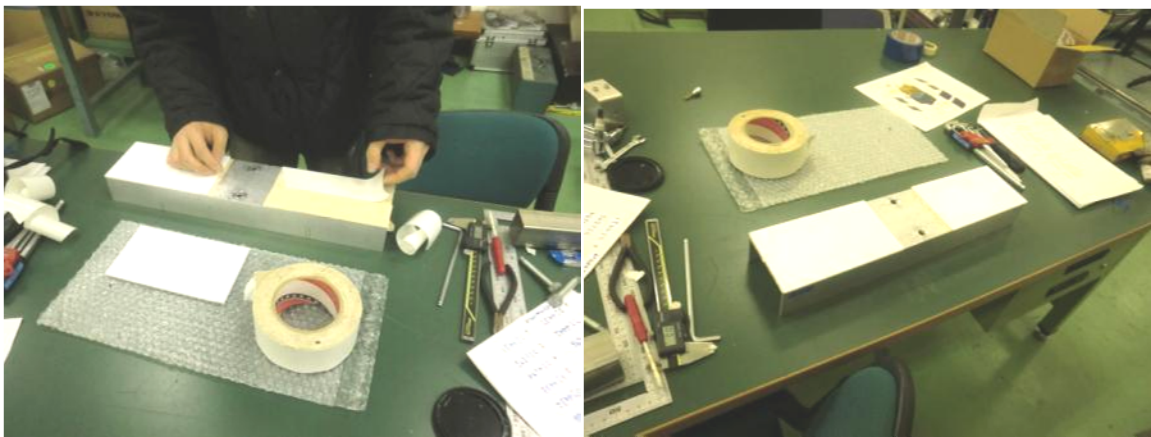

Figure 71 . Example of fixing Teflon sheet to base plate

Assemble the bone to the 133-8120 fixture; see drawing Figure 69 & 70 for details. Place the assembled fixture over the Teflon sheets see Figure 74. Do not tighten the two cap head screws item 7 in figure 69 at the end segments of the assembly to allow free rotation.

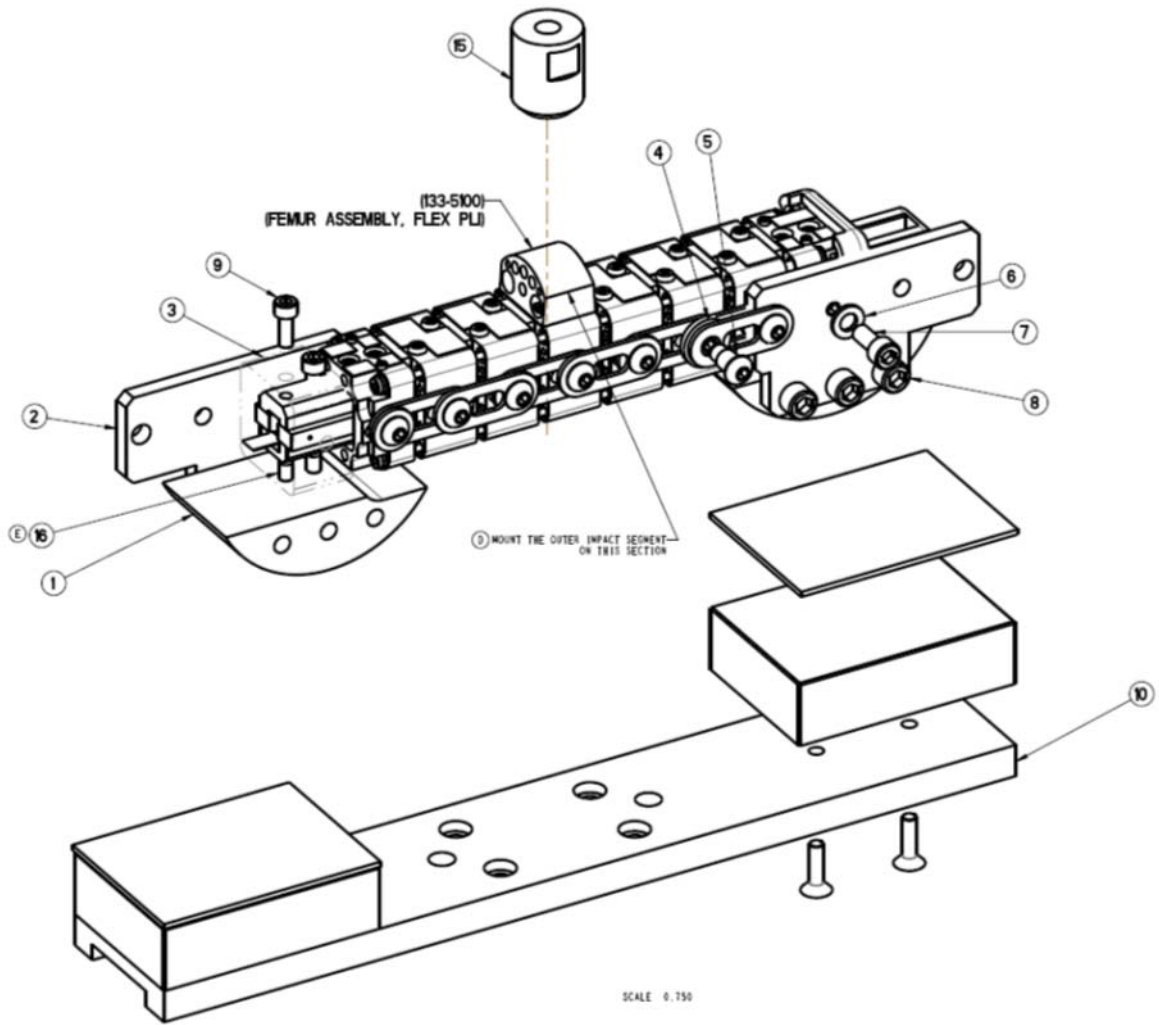

Figure 72 . Bone and knee fixture 133-8120 for static assembly bending test femur shown

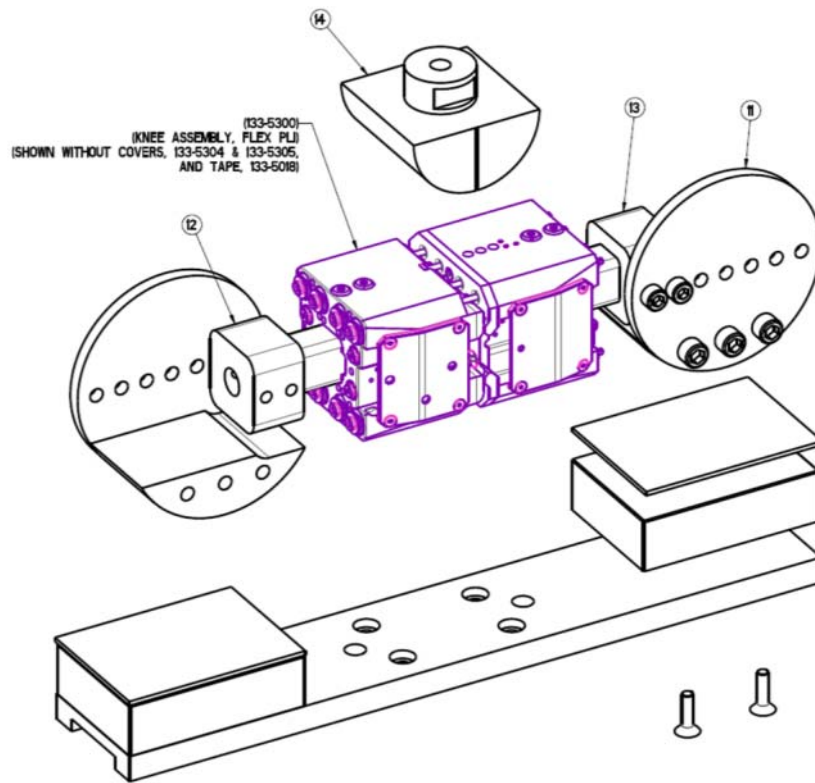

Figure 73. Static certification fixture 133-8120 showing knee

ITEM	QTY	PART NO.	DESCRIPTION
1	2	133-8125	PIVOT BASE
2	2	133-8124	SIDE PLATE, LEGS
3	1	133-8129	INSERT LEG PIVOT
4	2	133-8127	SPACER
5	4	133-8128	SHOULDER BOLT (11.90MM)
6	2	5000105	WASHER, FLAT M10
7	6	5000071	SCREW, SHCS M10 X 1.5 X 22
8	6	5000441	SCREW, SHCS M12 X 1.75 X 30
9	2	5000075	SCREW, SHCS M8 X 1.25 X 20
10	1	133-8150	BASE ASSEMBLY
11	2	133-8126	KNEE PIVOT SIDE PLATE
12	1	133-8121	KNEE CALIBRATION INSERT, FEMUR SIDE
13	1	133-8122	KNEE CALIBRATION INSERT, TIBIA SIDE
14	1	133-8105	KNEE LOADING PROFILE
15	1	133-8102	LEF LOADING SPIGOT
16	2	5000916	SCREW, MSSFP M8 X 12

Table 13. Parts List for static fixture 133-8120

The femur bone is loaded centrally on the forth plastic impact cover from the knee and on the tibia the fifth plastic impact cover (which is the centre of each bone). The loading spigot is connected to a high definition load cell on a load frame. Connect assembly to recording equipment.

The loading spigot is at zero load just touching the impact cover. Each bone assembly is loaded to 380 Nm. Check deflection/moment output must be inside corridor see Tables 14 and 15. Temperature for this test must be between 20 ± 2 °C. Note that the loading path from the machine must have no rubber damping otherwise the load curve will be inaccurate. To calculate moment loading centres, femur is 330mm and tibia 410mm. For femur moment $MF = [F (N)/2] \times 0.165 (m)$ and for tibia $MT = [F (N)/2] \times 0.205 (m)$. Loading rate is to be between 10 and 100 mm/min.

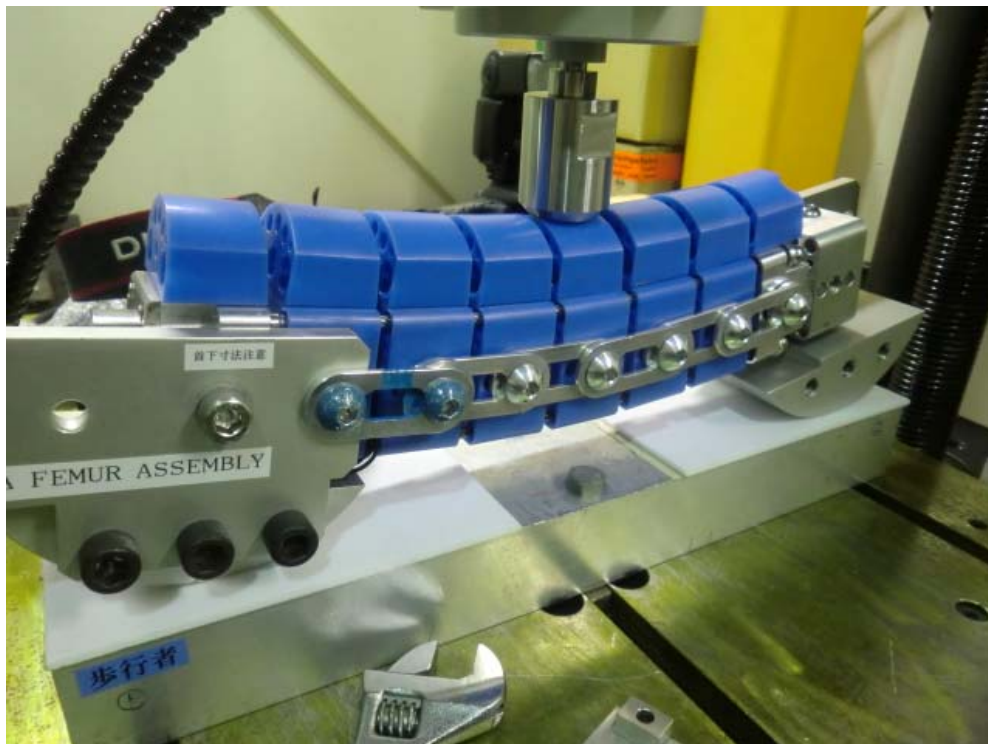

Figure 74 . Bone Assembly Fixture (femur shown under bending)

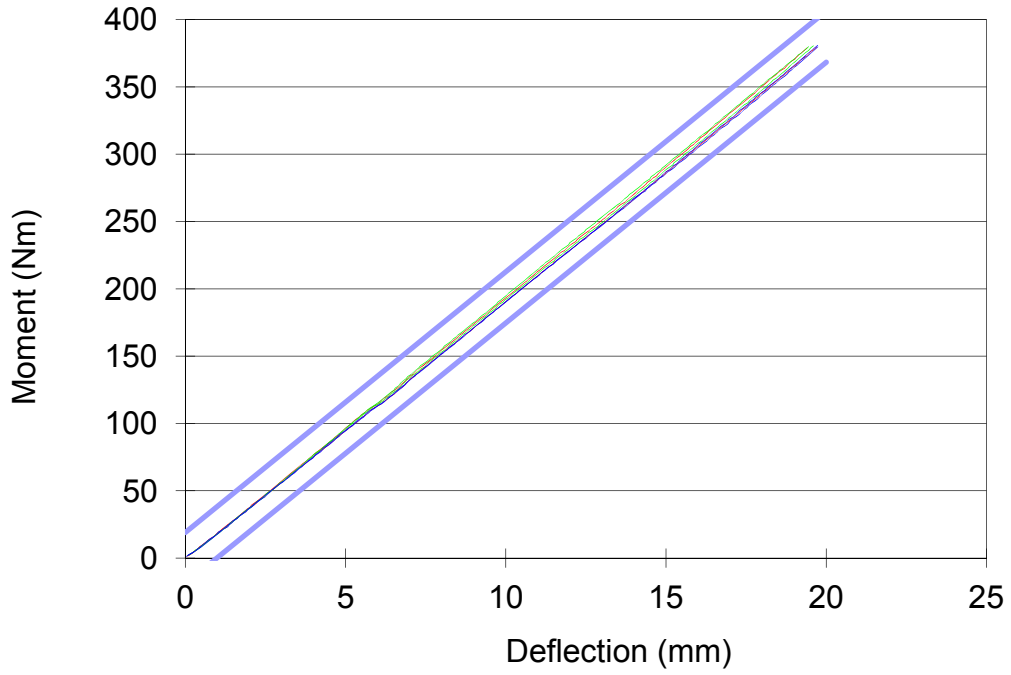

Figure 75 . Femur assembly certification corridor moment vs. deflection showing typical results

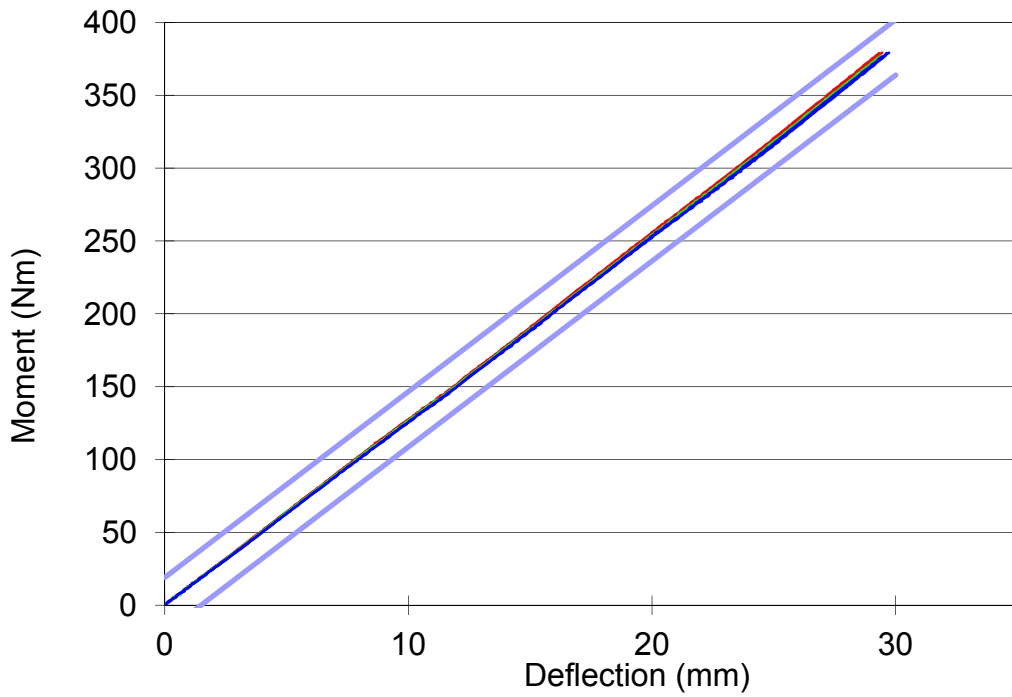

Figure 76 . Tibia assembly certification corridor moment vs. deflection showing a typical results

6.3 Knee Certification

This operation requires the use of a materials testing machine with high definition load cell and some parts from calibration fixture 133-8120 see Figure 73. Temperature for this test must be between $20 \pm 2^\circ\text{C}$. Locate the femur insert into the femur knee block, the femur insert is 3mm longer than the tibia insert so it is important the correct insert is in the correct knee block or results will be wrong. Fit 2x M8 x 35 BHCS and tighten, then fit the 2x M8 x 30 set screws on the opposite side and torque all screws to 8 Nm. Follow the same procedure for the tibia insert. Assemble the fixture as shown ensuring the impact side is on the top and the two blue plastic covers have been removed along with the accelerometer if fitted and double sided tape. It is important to check that the two knee blocks are aligned before starting the test to remove any shear or twist in the assembly. A procedure like that used in figure 84 can be used and double checked with a straight edge.

Place assembly over the center of the base plate with 3.2 mm thick Teflon sheets fitted with double sided tape as in Figure 71.

The testing machine must be fitted with $\varnothing 100\text{mm}$ 'D' shaped profile part 133-8105, see Figure 73. The center of the profile must be aligned with the top of the meniscus; a line is marked on the loading profile for this visual alignment. Plug string pots into recording equipment. A piece of Neoprene minimum size $85 \times 50 \times 5\text{mm}$ thick is placed over the loading point to prevent damage to the knee. The 85 mm dimension is the knee width dimension. This Neoprene is the same material used in the covers. The loading profile is brought down to contact the Neoprene at the zero load point. Then the test loading is started.

The knee is then loaded to 4 KN, speed rate must be between 10 and 100 mm/min. Calculate the bending moment at knee with: $M_k = [F/2] \times 0.2$.

LCL, ACL, PCL, and MCL string pot deflections are recorded. The LCL deflection is only checked for function in this test as it would be in compression. The results must be inside the corridors given in Figure 78 and 79. If the result does not fit into the corridor the springs may be tightened or loosened.

Humanetics recommends the nuts are not adjusted more than 1mm from the nominal flush washer position to the knee block to avoid affecting the designed full range of motion of the knee. The knee ligament outputs should all be positive, the LCL will bottom out around 3mm.



Figure 77 . Knee Certification Fixture

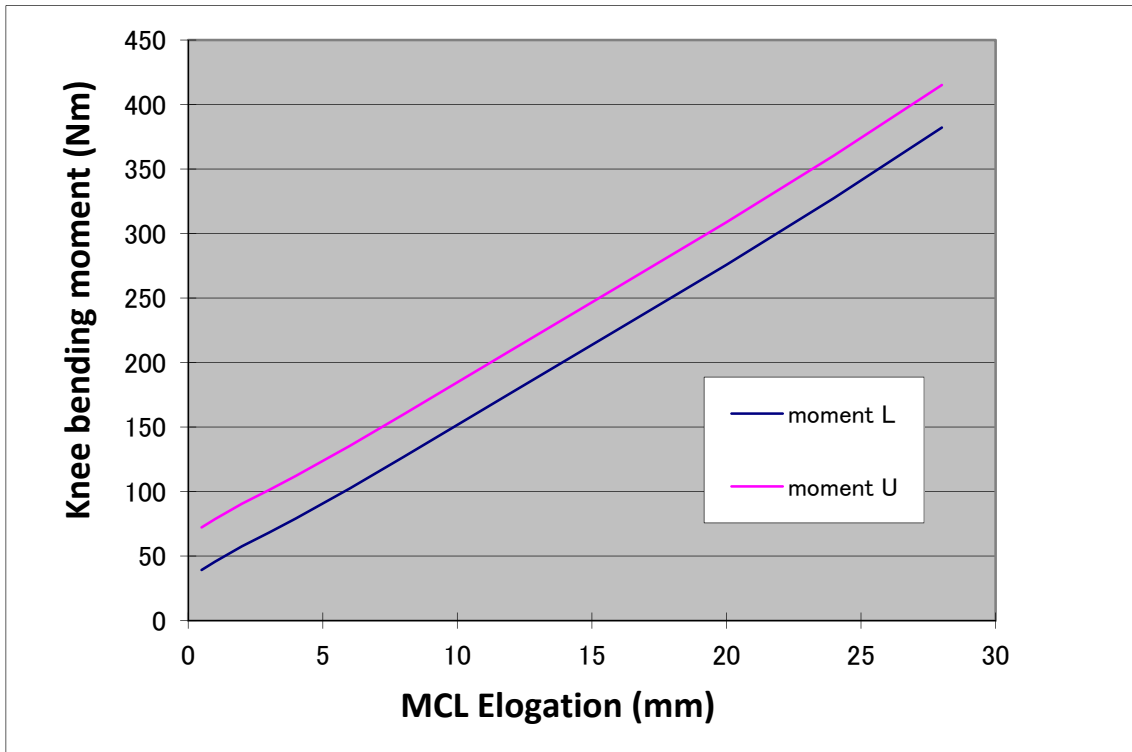

Figure 78 . Figure MCL sensor elongation Upper and lower corridor

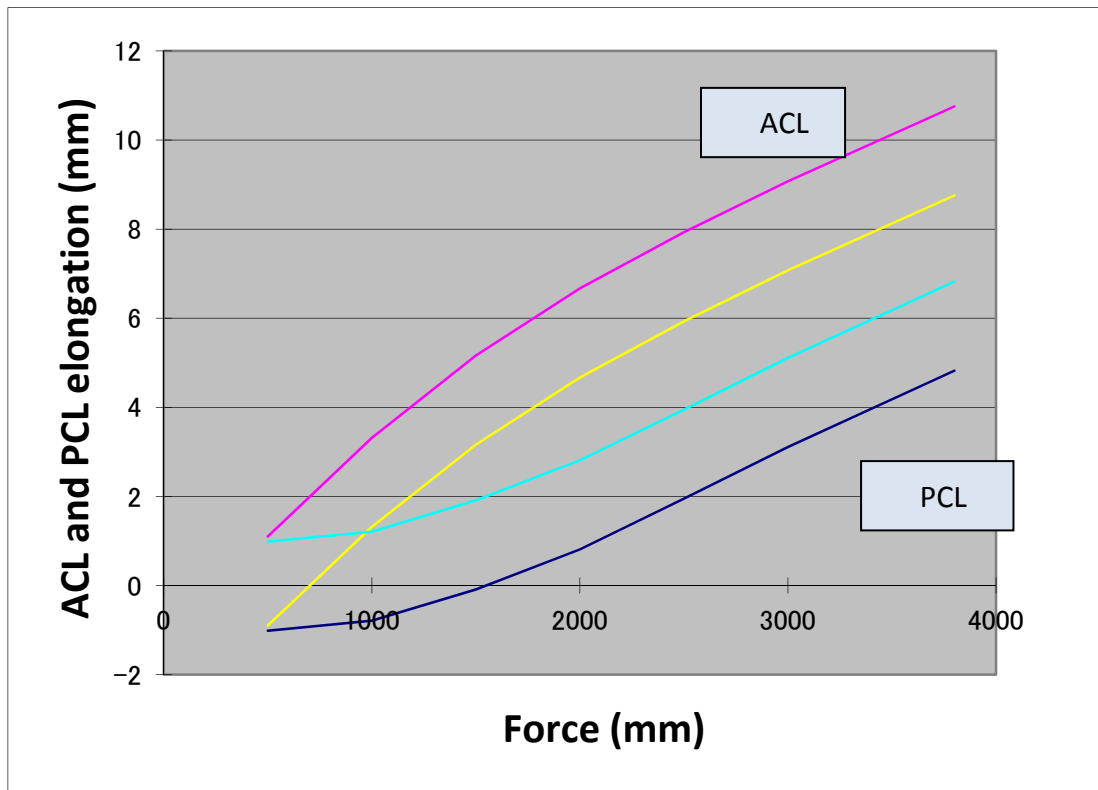

Figure 79 . Figure ACL and PCL upper and lower corridors

Section 7. Pendulum Dynamic Certification

7.1 Introduction

The dynamic pendulum certification test is carried out on the Dynamic Certification Test Rig, Part Nr 133-8400, as diagrammatically shown in Figure 73. Only 7 channels are required and must meet the proposed GTR9 requirement see Table 17. For assembly instructions of the test rig refer to 7.2.

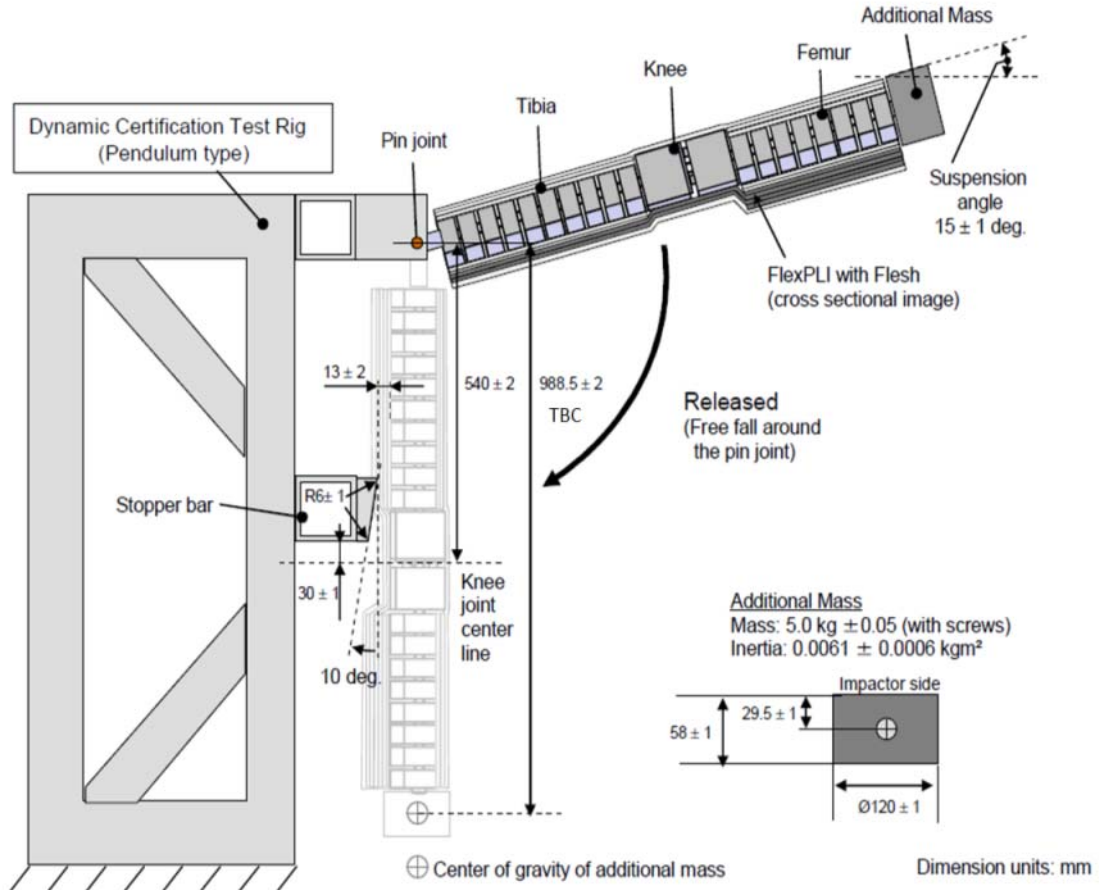

Figure 80 . Diagram of Dynamic Pendulum Fixture

This test is carried out at build and mandatory after every 10 vehicle tests. This test can be carried out at any time if required to check the leg before testing. The test must be carried out at a stabilized temperature of $20^\circ\text{C} \pm 2$ and must be recorded. The leg assembly is tested with the flesh cover parts fitted and the leg is upside down, so that the leg pivots from the bottom of the tibia. This is to increase the amount of test energy to a similar loading level of a vehicle impact, an additional 5.0kg mass is also added to the femur end.

7.2 Pendulum Rig Assembly Instruction

If the assembly has been stripped down, use the following steps to assemble the rig. Otherwise skip this and go to the next section.

Stand the Left and Right support weldments, (133-8401 & 133-8402) opposite each other and about 400mm apart, ensure the tapped hole flanges are facing inwards. Fit the cross bars (133-8412) and tighten, this will bring the side supports together. Now loosen the screws on the cross bars and fit Impact Bar (133-8420) and pivot cross bar (133-8415) tighten the screws this will pull the support weldments square with the Impact and pivot cross bars. The Cross Bar screws can now be tightened.

The top 'A' frame assembly can be assembled on the ground and lifted on to the base or assembled directly on to the base. Note it will be important to keep all the screws loose while the parts are being fitted. Fit the two 'A' Frames (133-8424), then fit two side supports making sure diagonals go in the opposite direction. Do up all the bolts so there is no slack but the parts can still move.

Fit the top cross member (133-8431) and then tighten all the screws ensuring the top cross member is in line with the impact face. Fit the pivot clearance block. Fit the control release box, this can be fitted either side depending on user requirement. Fit the release latch and connect up to the control box, tape or loop the wire to the frame. The control box comes with a gate switch. If a safety barrier is required around the fixture during testing, this gate switch can be used in the barrier to ensure the barrier gate is closed during the testing.

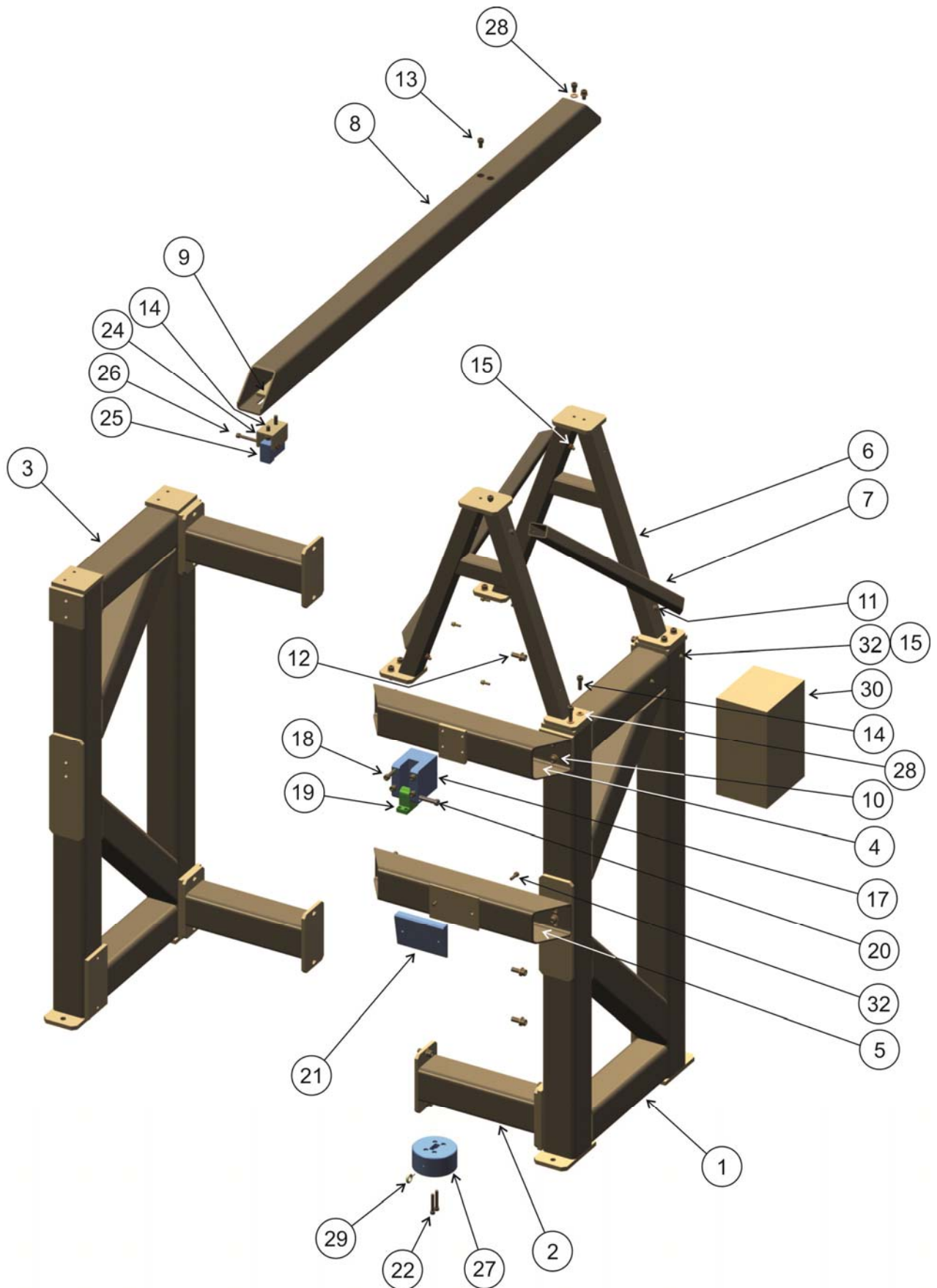

Figure 81 . Exploded view Dynamic Rig part nr 133-8400

ITEM	QTY	PART NO.	DESCRIPTION
1	1	133-8401	LEFT BASE SUPPORT WELDMENT
2	3	133-8412	BASE CROSS BAR WELDMENT
3	1	133-8402	RIGHT BASE SUPPORT WELDMENT
4	1	133-8415	PIVOT CROSS BAR WELDMENT
5	1	133-8420	IMPACT BAR WELDMENT
6	2	133-8424	A-FRAME SUPPORT
7	2	133-8429	A-FRAME SIDE SUPPORT
8	1	133-8431	TOP CROSS MEMBER
9	1	133-8432	NUT PLATE
10	20	5000267	WASHER, FLAT M12 (13.0 ID X 24.0 OD X 2.5 THK.)
11	4	5000587	SCREW, SHCS M8 X 1.25 X 70
12	20	5000441	SCREW, SHCS M12 X 1.75 X 30
13	4	5000314	SCREW, SHCS M10 X 1.5 X 16
14	10	5000444	SCREW, SHCS M10 X 1.5 X 30
15	8	5000552	WASHER, FLAT M8 (8.4 ID X 16.0 OD X 1.6 THK.)
16	5	5000486	HEX NUT, M8 NYLOK
17	1	133-8419	PIVOT CLEARANCE BLOCK
18	4	5000785	SCREW, SHCS M10 X 1.5 X 120
19	1	133-8418	PIVOT HINGE
20	1	5000786	SCREW, SHSS M12 X 50
21	1	133-8423	IMPACT BLOCK
22	2	5000028	SCREW, SHCS M8 X 1.25 X 50
23	6	9000244	WASHER, FLAT ¼"
24	1	133-8438	BRACKET RELEASE MECH
25	1	6002571	RELEASE SYSTEM (TENNEN BV 099-005-A)
26	1	5000499	SCREW, SHCS M8 X 1.25 X 60
27	1	133-8436	CALIBRATION BALLAST FEMUR
28	10	5000105	WASHER, FLAT M10 (10.85 ID X 20 OD X 2.5 THK.)
29	1	5000797	EYEBOLT, M6 X 1 X 12, ZINC-PLATED (MCM#3107T41)
30	1	6002575	RELEASE SYSTEM CONTROL BOX (TENNEN BV TE-RSCB-100)
31	6	5000001	SCREW, SHCS M6 X 1 X 20
32	2	5000030	SCREW, SHCS M8 X 1.25 X 25
33	1	6001587	CONNECTOR SOCKET (NOT SHOWN)
34	2	6001588	SOCKET TERMINAL (NOT SHOWN)
35	2	6001737	PIN TERMINAL (60618-1 NEWARK)
36	1	6001738	CONNECTOR, AMP MATE-N-LOCK (NOT SHOWN)
37	11 FT.	6003042	SERVICE CORD (16AWG 2-CONDUCTOR) (NOT SHOWN)

Table 14. Pendulum Dynamic Rig Part List

7.3 Leg Preparation for Pendulum Dynamic Calibration

Step 1: Check the eight M8 set screws shown in Figure 82 are tightened to 8 Nm;

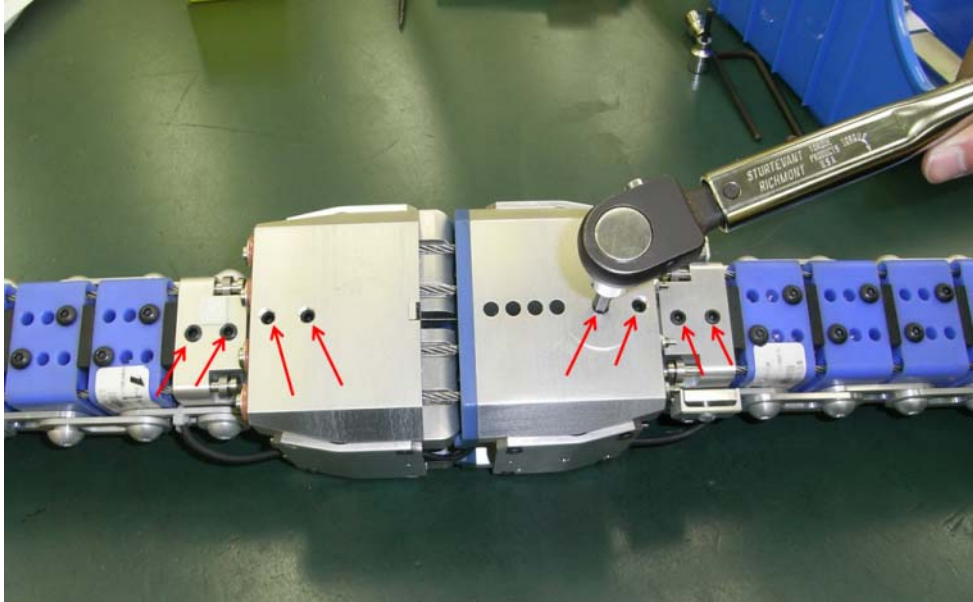

Figure 82 . Check screws with 8 Nm torque

Step 2: After 60 vehicle tests remove the knee blue front covers and check the 4x M8 button head screws attaching the legs are tightened to 8 Nm;

Step 3: Check the four stop cable clearances passing through the femur are set to 9.1 mm and 10.3 on the tibia. See figure 83 a special tool 133-5112 is used for this;

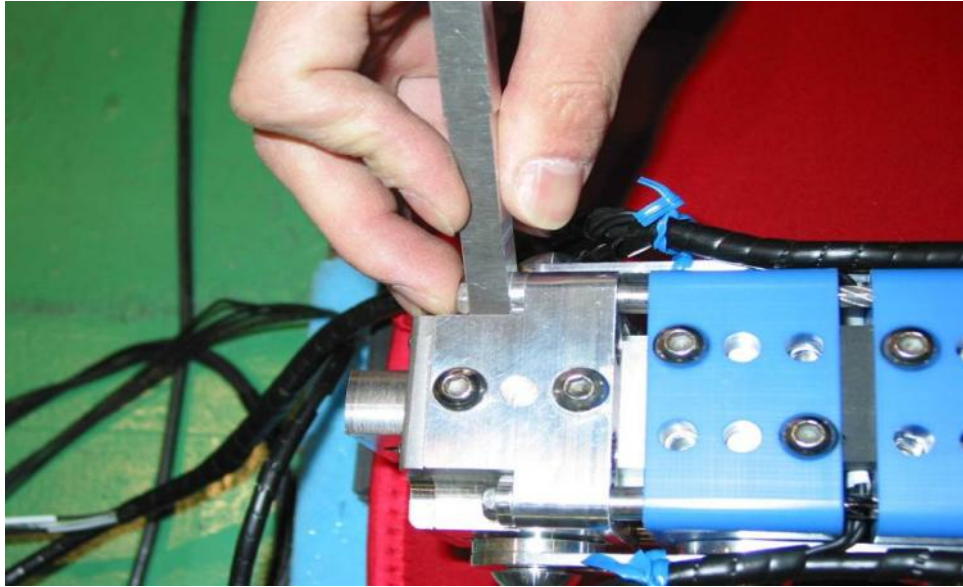

Figure 83 . Stop cable clearance adjustment using setting tool

Step 4: Check knee blocks are aligned to ensure knee is not twisted or in a shear condition before the test. Using two equal height blocks push down on the back of the knee for y direction and also on one side of the knee for x direction as shown in picture below. A straight edge can be used to double check alignment after any adjustment. See Figure 84;

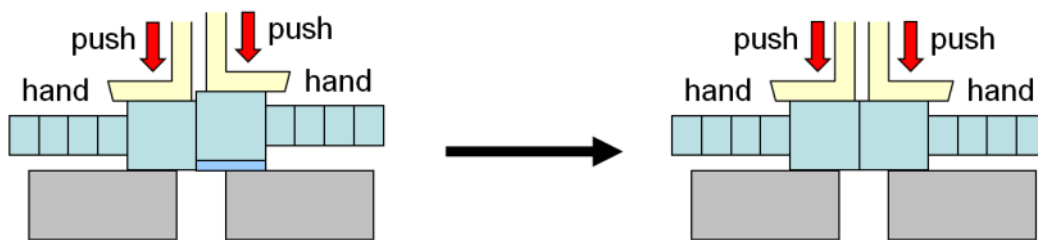

Figure 84 . Recommended method to align knee to remove any twist and shear

Step 5: Check all segment screws and side aluminum shoulder screws are tightened to 3 Nm. The impact covers would need removal to check front segment screws;

Step 6: Remove the aluminum launch guide (Figure 47 item 18, Part Nr 133-5103,) U shaped bracket fitted to the top of the femur along with the black protective cover (Figure 47 item 28, Part Nr 133 - 5516);

Step 7: Attach the ballast weight (Part Nr 133-8436) as shown in Figure 85 to the top of the femur using two M8 x 50 long cap head screws;

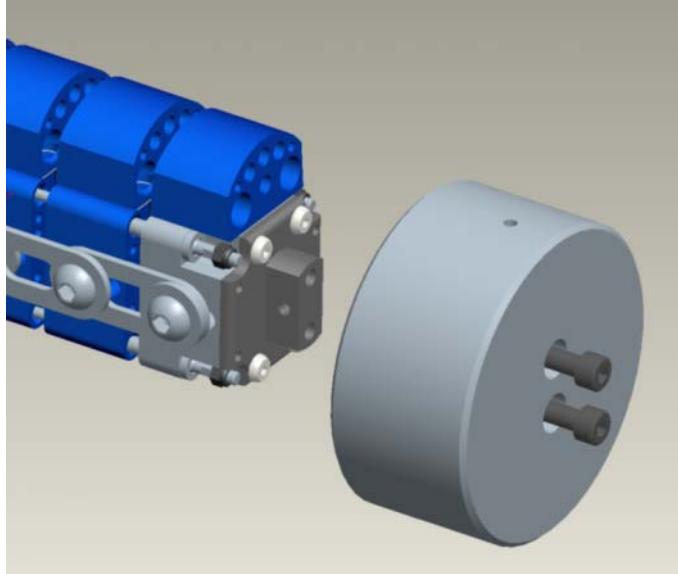

Figure 85 . Attaching Pendulum Ballast Weight

Step 8: Remove the black protective cover (Part Nr 133 – 5516) from the tibia bottom and attach the Pivot Hinge (Part Nr 133-8418) as shown in Figure 86 using four M6 x 18 long screws.

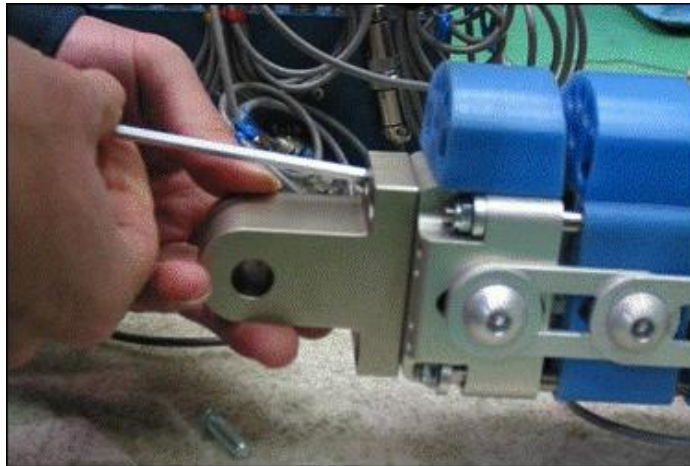

Figure 86 . Attaching Pendulum Rig Pivot hinge

Step 9: See next step in section 7.3 for fixture preparation. The checking and adjustment of the pendulum Impact Block (Part 133–8423) must be done with a bare leg without the suit. Check the Impact block is adjusted to the specification, fit the suit according to the instructions in section 3.3.5 allowing for the electrical wires to exit at the end of the Pivot Hinge at the top of the (upside down) leg. The leg is now ready to be hung on the rig.

7.4 Pendulum Rig Preparation

Suspend the bare leg (without suit) on the fixture with the Pivot Hinge in the Pivot Clearance Block and the Shoulder Bolt (Figure 81, item 17 and 20). Check that the distance from the bottom of the Impact Block is 30 ± 1 mm above the top of the plastic blue Meniscus (Figure 53 item 2, Part Nr 133 – 5313) of the knee and 13 ± 2 mm from the front of the impact face (point nearest to the leg) to the impact

segments of the tibia. Adjust the height of the Impact Block by moving the Impact Bar Weldment (Figure 81, item 5) up or down (4 screws that mount tube to frame). Adjust the horizontal Impact Block to Leg distance to 13 ± 2 mm by adding add shims to the back of the Impact Block or the Pivot Clearance Block.

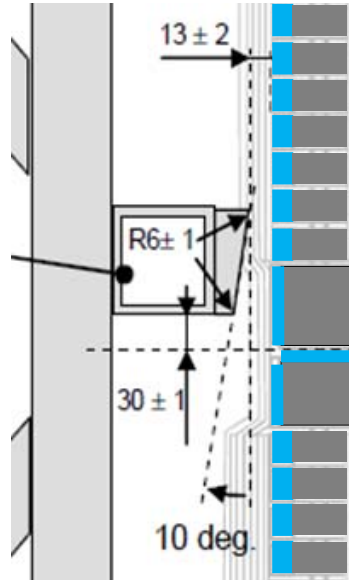

Figure 87 . Checking the Impact Block position adjustment

Next step is to make a loop of steel wire rope of the proper length, such that the drop angle matches the required suspension angle of $15^\circ \pm 1^\circ$ above horizontal (Figure 80). Suspend the leg with the Pivot Hinge to the Pendulum Rig. The leg is lifted up to the release mechanism (figure 88) and held in position with the steel wire rope attached to the ballast weight. Adjust the loop length to the required suspension angle of $15^\circ \pm 1^\circ$. Check the angle with a digital inclinometer laid on the back of the knee. The steel rope is tied to the ballast weight via an eye bolt which can be used for fine height adjustment. The Pendulum Rig is now ready for running a test.

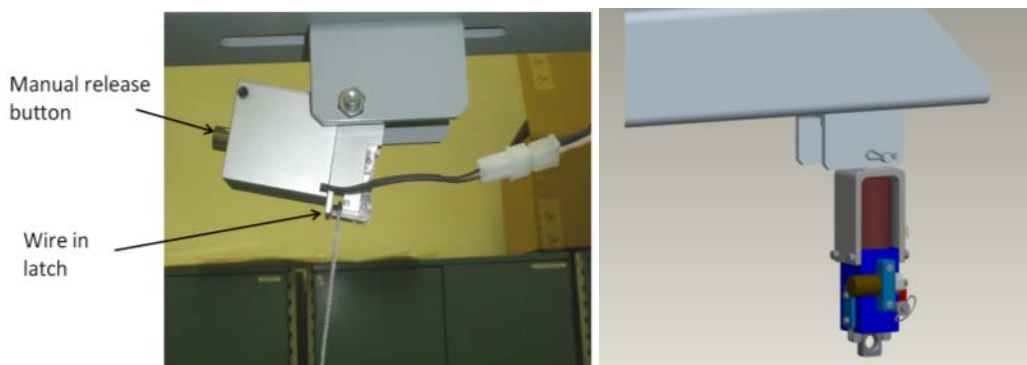

Figure 88 . Examples of release latches

7.5 Running a test

The test facility used for the certification must have a stabilized temperature of 20 ± 2 °C during the certification and the temperature is to be recorded.

Step 1. Hook up the sensors on the Data Acquisition System (DAS) and check the sensor polarities (Section 2.3.2 and figure 15) by flexing the leg.

Step 2. Fit the suit according instruction in section 3.3.5 allowing for the electrical wires to exit at the end of the Pivot Hinge at the top of the (upside down) leg. The leg is now ready to be hung on the rig.

Step 3. Fit the leg to the pivot block on the rig using the M10 Socket Head Shoulder Screw (SHSS). Route the disconnect wire as required out of the end of the tibia or below the knee depending on type of DAS and tape up to the rig so that it does not interfere with the free swing motion of the leg when tested. If using off board DAS the wires are routed out of the top of the leg.

Step 4. With the leg hanging down vertically, start up and initiate the DAS and set the DAS such that the sensors are zeroed to zero sensor output in this position. **Important: The leg sensors are zeroed in the vertical impact position before lifting to 15 degree above horizontal.**

Step 5. The leg is lifted up to the release mechanism and held in position using the steel wire rope loop attached to the ballast weight. The rope has been made so that the angle of the leg before release is 15° above the horizontal. Check once more the angle with a digital inclinometer on the back of the knee. The steel rope is tied to the ballast weight via an eye bolt, which can be used for fine height adjustment.

WARNING: After the impact the leg swings back violently and can seriously injure anyone standing in the rebound area. Releasing the leg must be done from the side of the rig; under no circumstances should anyone be behind the leg or in its swing plane during testing. It is highly recommended that a safety barrier is erected in the swing/rebound area ensuring no one is inside the drop zone during release to avoid any injury. The release can be switched through a safety system and a control box that can only be operated with the barrier closed ensuring that no one is in close range of the rebounding leg.

Step 6. Arm the DAS system and release the leg. The trigger for data collection can be from the accelerometer on the leg, started manually or from a speed gate. After initial impact the leg will continue to bounce, where possible the leg should be caught or stopped to prevent this. The springs in the knee and the elastic response from the rubber flesh create a strong rebound. If there is any doubt about safety allow the leg to bounce after impact.

If a test is to be repeated the leg should rest for 45 minutes minimum before repeating. If another flesh set is used the test does not need to wait 45 minutes.

7.6 Data Processing

All data shall be filtered CFC180. The certification corridors of all the GTR9 injury channels are given in Table 15. These peak values are to be within 250 ms after impact.

GTR Pendulum Dynamic Calibration Results	Peak Moment @ Tibia Gage 1	Peak Moment @ Tibia Gage 2	Peak Moment @ Tibia Gage 3	Peak Moment @ Tibia Gage 4	Peak ACL Elongation	Peak MCL Elongation	Peak PCL Elongation
Unit	Nm				mm		
Upper	272	219	166	111	10.5	24.0	5
Lower	235	187	139	90	8	20.5	3.5

Table 15. Pendulum test corridors

Section 8. Dynamic Inverse Certification Test

8.1 Introduction

To ensure a certified dynamic response of the FLEX-PLI-GTR leg, the Dynamic Inverse Certification must be done after the initial manufacture and repeated after no more than 30 vehicle tests. The preparation for the leg and execution of the test is described in this section. The 7 injury channels must meet the test corridors as per the proposed GTR 9 specification.

8.2 Inverse Test Description

The inverse test is a dynamic calibration test where the fully assembled leg is suspended stationary vertically $\pm 2^\circ$ from a sprung hook which releases within 10 ms after impact. The leg is struck with a linear guided impactor of 8.15 ± 0.1 kg mass including the honeycomb face with an impact velocity of 11.1 ± 0.2 m/s (40 kph the same speed as the GTR9 vehicle test). The linear guided impactor face must contact the knee within ± 2 mm vertically from the top of the blue Meniscus (top of tibia knee block). A schematic of the test set up is given in Figure 89.

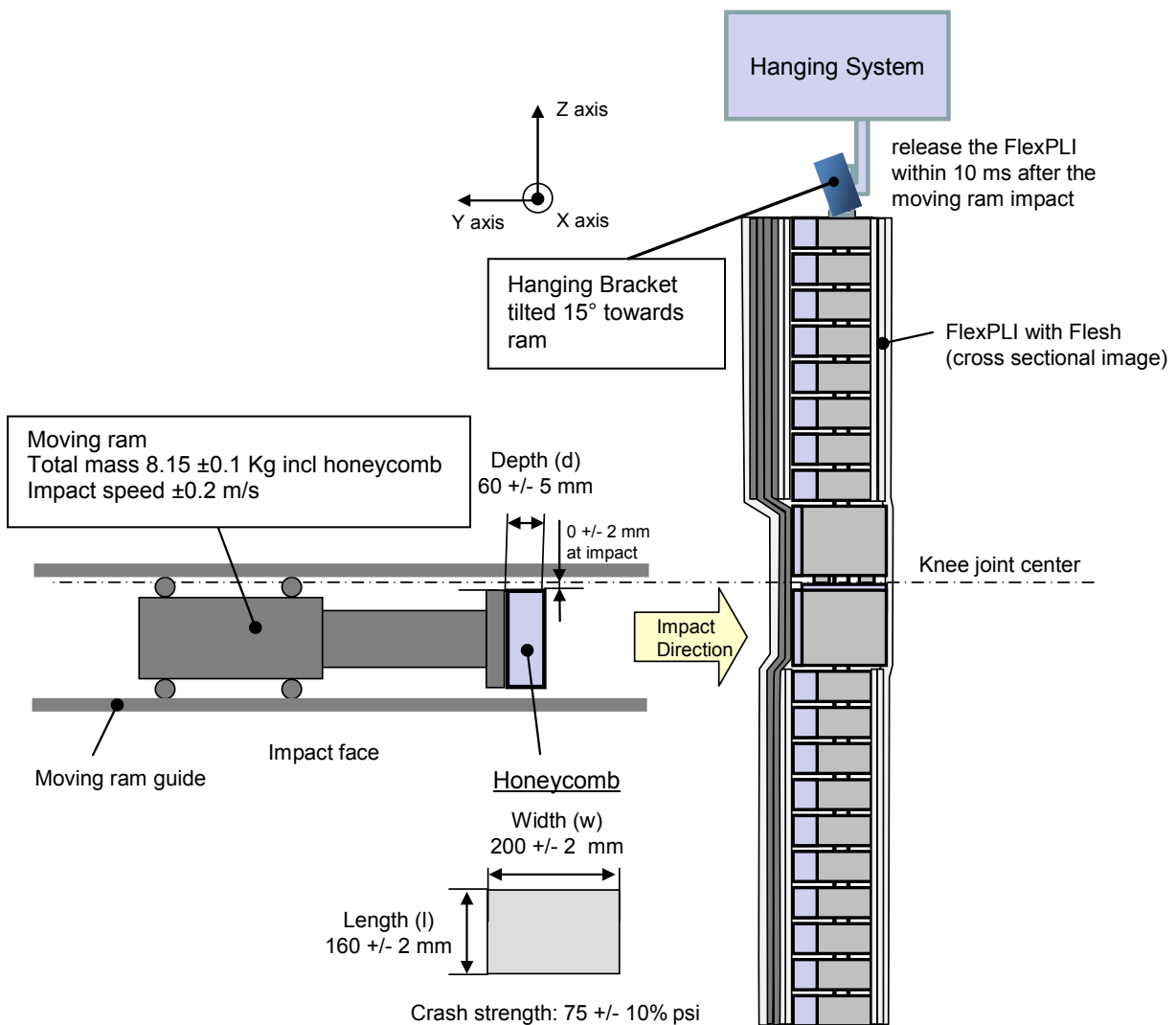

Figure 89 . Diagram of Dynamic Inverse Certification Test set up

8.3 Preparation of the Inverse Test set up

The linear guide impactor face is covered with 5052 Aluminum honeycomb with a crush strength of 75 PSI \pm 10. The size of the honeycomb is width 200 \pm 2mm, length 160 \pm 2mm and depth 60 \pm 5mm. The honeycomb is specified as 3/16" cell size with a density of 3.1 or 2.0 pcf (pounds per cubic foot) or 1/4" cell size with density of 2.3 pcf.

The honeycomb block is covered with paper cloth of less than 1mm thick. See Figure 90. The paper cloth is wrapped around the honeycomb and taped at the back to hold in position. The paper helps to prevent damage to the leg covers.

It is recommended to fix the Honeycomb to the impactor using strong double sided tape to help maintain position on impact. The top of the impactor plate must be in line with the honeycomb at time of first contact and the upper edge of the honeycomb must be in line with the knee joint (top of blue tibia knee block) \pm 2 mm.

On impact the leg is to be released from the hanging bracket within 10 ms to ensure free flight condition.

The impactor free travel and travel during impact are important to obtain good results. The linear guided impactor must be free to stroke during the entire duration of the contact with the leg. Humanetics recommends a free travel of 70mm before impact and allowed travel after first contact of 190 to 220 mm to ensure all energy from the impactor is transferred during the contact period.

The speed should be measured in the free travel phase ideally at a sample rate around 100 MHz due to the high speed and just before impact.

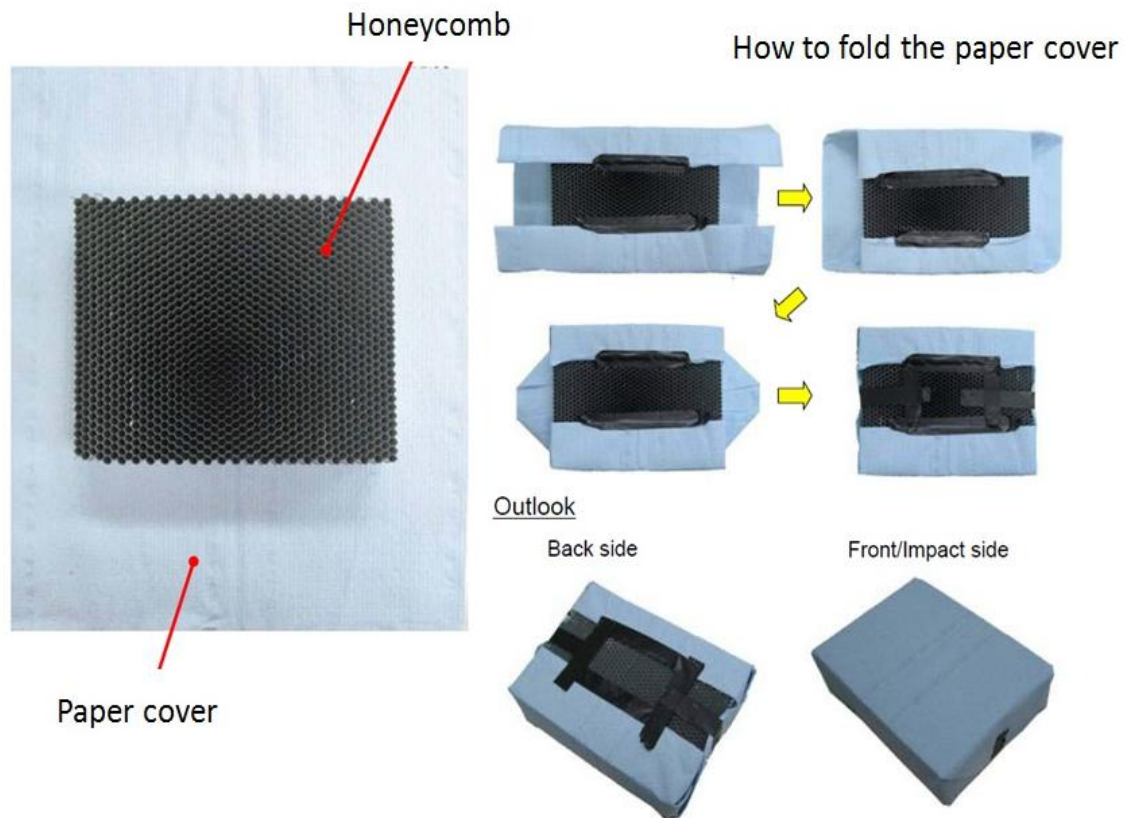

Figure 90 . Paper cloth wrapping of honeycomb

8.4 Leg Preparation of the leg for Dynamic Inverse Test

Step 1: Check the eight M8 set screws shown below are tightened to 8 Nm.

Step 2: After 60 vehicle tests remove the knee front covers and check the 4x M8 button head screws attaching the legs are tightened to 8 Nm

Step 3: Check the four stop cable clearances passing through the femur are set to 9.1 mm and 10.3 on the tibia. See figure 83 a special tool 133-5112 is used for this.

Step 4: Check knee blocks are aligned to ensure knee is not twisted or in a shear condition before the test. Using two equal height blocks push down on the back of the knee for y direction and also on one side of the knee for x direction as shown in picture below. A straight edge can be used to double check alignment after any adjustment. See figure 84.

Step 5: Check all segment screws and side aluminum shoulder screws are tightened to 3 Nm.

Step 6. Hook up the sensors on the Data Acquisition System (DAS) and check the sensor polarities (Section 2.3.2 and figure 15) by flexing the leg.

Step 7: Fit the inner flesh system as described in 3.3.5

Step 8: Check all wires are correctly positioned to avoid damage and any exit wires are restrained.

Step 9: Fit the outer skin cover.

The leg is now ready for suspension on the test rig.

8.5 Running a Dynamic Inverse Test

The test facility used for the certification must have a stabilized temperature of 20 ± 2 °C during the certification and the temperature is to be recorded.

The pitch angle of the impactor (rotation around y-axis) at the time of first contact shall be within a tolerance of $0 \pm 2^\circ$ in relation to the lateral vertical plane. The roll angle of the impactor (rotation around x-axis) at the time of first contact shall be within a tolerance of $0 \pm 2^\circ$ in relation to the longitudinal vertical plane. The yaw angle of the impactor (rotation around z-axis) at the time of first contact shall be within a tolerance of $0 \pm 2^\circ$.

Step 1. Suspend the leg on the inverse test rig on the release mechanism with its launch guide.

Step 2: Make sure the launch guide at the top of the femur is locked tilting 15° towards the impactor. Lock in position using the two M6 screws both sides. This allows the leg to hang vertically on the spring loaded release mechanism. See Figure 91 below.

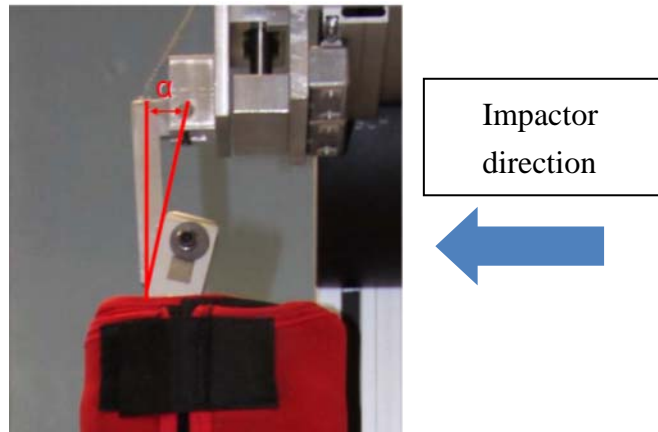

Figure 91 . Launch guide with 15° tilt toward guided impactor

Step 3. With the leg hanging down vertically, start up and initiate the DAS and set the DAS such that the sensors are zeroed to zero sensor output in this position. **Important: The leg sensors are zeroed in the vertical impact position.**

WARNING: After the impact the leg is thrown violently away from the test rig and can seriously injure anyone standing in the flight area. It is highly recommended that a safety barrier is erected in the flight area ensuring no one is inside this danger zone during the test to avoid any injury.

Step 4. Arm the DAS system and release the linear guided impactor. The trigger for data collection can be from the accelerometer on the leg, contact switch or from a speed gate.

If a test is to be repeated the leg should rest for 45 minutes minimum before repeating. If another flesh set is used the test does not need to wait 45 minutes.

8.6 Data Processing

All data shall be filtered CFC180. The Inverse Certification corridors of all the GTR9 injury channels are given in Table 16. Peak values shall be within 50 ms after impact.

GTR Inverse Dynamic Calibration Results	Peak Moment @ Tibia Gauge 1	Peak Moment @ Tibia Gauge 2	Peak Moment @ Tibia Gauge 3	Peak Moment @ Tibia Gauge 4	Peak ACL Elongation	Peak MCL Elongation	Peak PCL Elongation
Units	Nm				mm		
Upper	272	252	192	108	10.0	21	6.0
Lower	230	210	166	93	8.0	17	4.0

Table 16. Inverse test corridors

For further details of the test requirements refer to document ECE/TRANS/WP.2.9/GSRP/2009/21

Section 9. Vehicle Test

9.1 Introduction

For the vehicle test a special launch plate or pusher is required which is attached to a firing ram or launch system, for an example see Figure 94. The design of the pusher and stroke length is important to maintain stable release conditions when the leg leaves the launcher. The leg is fired at the vehicle at 40 kph or 11.1 m/s \pm 0.2.

For the specifications and requirements of the test refer to ECE/TRANS/WP.2.9/GSRP/2009/21

9.2 Leg Loading limits in free flight

The loading level of the impactor during free flight for tibia bending moments are recommended to be less than +/- 10 Nm and for knee ligaments (MCL, ACL, PCL) elongations are recommended to be less than +/- 1mm. If there are oscillations in the leg when fired, adjusting the height of the bone pushing pads on the launcher plate should prevent this. The thicker covers of the femur and tibia are softer than the knee which can generate more pushing load at the knee than over the bones creating an oscillation in flight. The aim would be to get an even push along the whole length of the leg. Depending on the acceleration and stiffness of the pusher different users will need different pusher pad heights to avoid oscillation.

The side link shoulder screws on the aluminium segments can become loose in testing. It is an option to use a weak thread lock on these to prevent them coming loose.

9.3 WARNING! VIOLENT REBOUND!

After impact with the vehicle the leg can be thrown high into the air or can be deflected some distance in any direction depending on the geometry of the bumper. Therefore it will be important to protect anyone exposed in the test lab. Laboratory staff must be clear of the test site and they must be behind suitable barriers during the launch.

9.4 Catch Rope

A catch rope attachment bracket is available to attach at each end of the leg allowing a 4 point rope attachment. The protective covers are removed and replaced with high strength aluminum Catch Rope Bracket, see Figure 92. This allows the leg to be tied into a frame preventing any damage or injury from rebound. The ropes are quickly retracted after impact to keep the leg inside the frame.

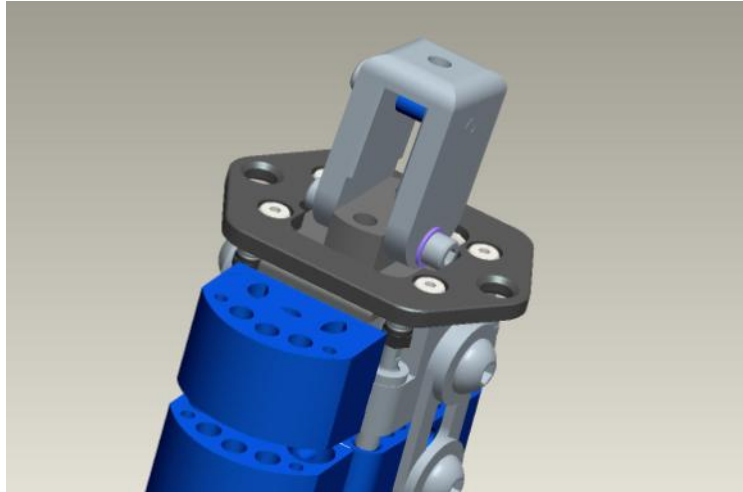

Figure 92 . Optional catch rope bracket 133-5034

9.5 Impactor Pusher Plate

To obtain a stable release the pusher system must be very stiff and to help with acceleration away from the ram the pusher assembly should have low mass. The Impactor pusher guides must be set to 113mm as shown in Figure 93 below.

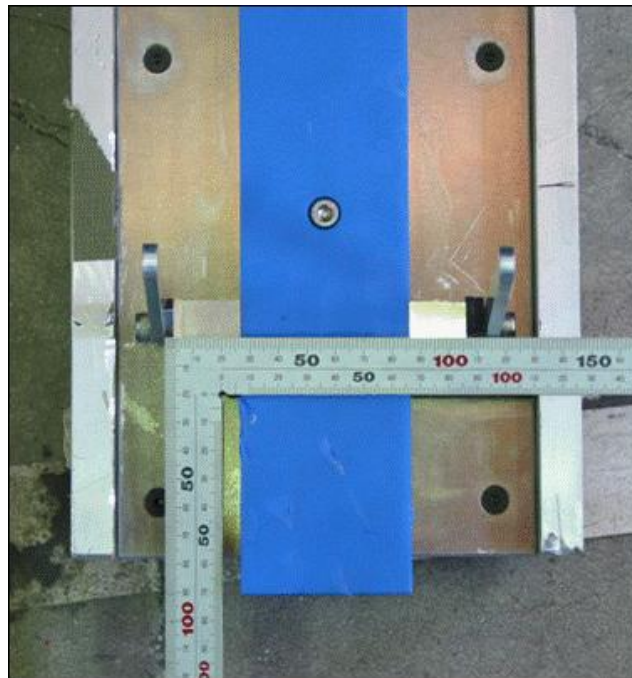

Figure 93 . Impactor guide width setting 113mm

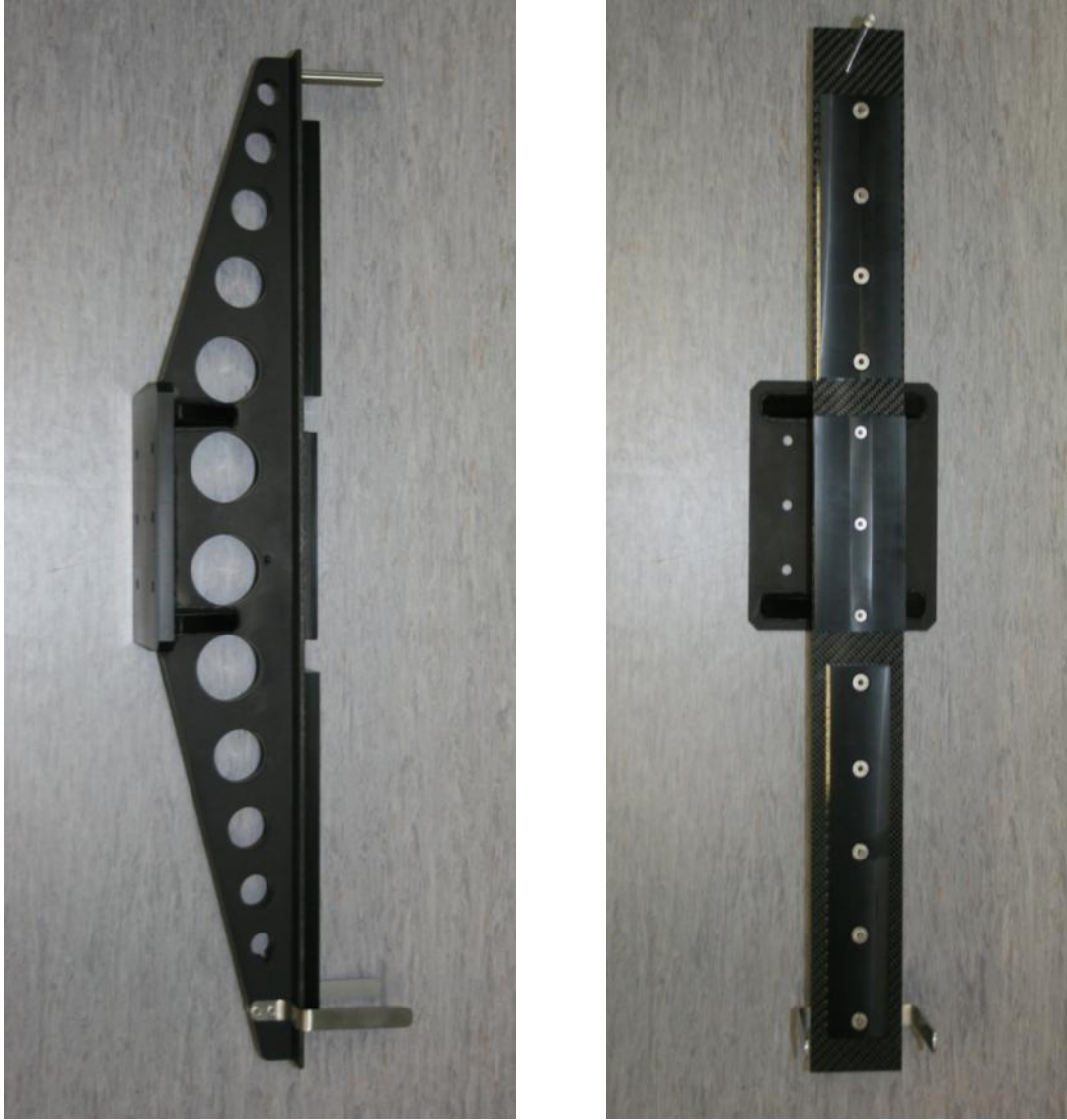

Figure 94 . Humanetics Launch plate Part Nr 133-8200 (Aluminum and Carbon Fiber)

The interface plate that attaches to the launcher is drilled to match customer hole pattern.