

DRAFT

**Global technical regulation No. XX**

POLE SIDE IMPACT

## A. STATEMENT OF TECHNICAL RATIONALE AND JUSTIFICATION

### 1. INTRODUCTION AND PROCEDURAL BACKGROUND

At the 150<sup>th</sup> session of WP.29 in March 2010, Australia introduced an informal document (WP.29-150-11), proposing the development of a global technical regulation (gtr) on pole side impact. There were five key elements to this proposal, namely that:

- i) a high number of fatalities occurred in pole side impacts (that is, impacts with narrow objects such as telegraph poles, signposts and trees) and other side impacts in Australia and other countries;
- ii) there was wide variation between side and pole side crash tests both in regulation and voluntary standards;
- iii) there was wide variation between the crash dummies being used in the crash tests and concerns over their biofidelity, raising concerns about their effectiveness in predicting real world injury outcomes;
- iv) the development of the WorldSID, with its superior biofidelity, provided a unique opportunity to improve the international crash test regime for side impacts through development of gtr on pole side impact, thereby improving the safety of motorists and minimising costs to consumers and industry; and
- v) a pole side impact standard was likely to produce benefits for side impacts generally by driving improvements in head protection.

AC.3 requested the secretariat to distribute WP.29-150-11 with an official symbol for consideration and vote at the June 2010 session. It was agreed to transmit WP.29-150-11 to GRSP to consider at its May 2010 session and to assess the need for an informal group.

At its 47<sup>th</sup> session in May 2010, GRSP considered Australia's formal proposal (ECE/TRANS/WP.29/2010/81) together with a further informal paper (GRSP-47-28), which included a proposed task list (subsequently developed into terms of reference), and endorsed establishment of an informal group under the chairmanship of Australia, subject to the consent of AC.3.

At the 151<sup>st</sup> session of WP.29 in June 2010, AC.3 considered Australia's formal proposal and agreed to develop the gtr and to establish the Informal Group. AC.3 also agreed that the initial tasks of the Informal Group should be to (i) confirm the safety need for a gtr in light of the increasing prevalence of electronic stability control in the vehicle fleet and (ii) simultaneously assess potential candidate crash test standards to be addressed by the proposed gtr. The proposal is included among the *Proposals for developing gtrs*, adopted by AC.3 (ECE/TRANS/WP.29/AC.3/28).

In subsequent major developments, at the 154<sup>th</sup> session of WP.29 in June 2011, AC.3 adopted the terms of reference of the informal group and its first progress report (ECE/TRANS/WP.29/2011/87).

At the 157<sup>th</sup> session of WP.29 in June 2012, AC.3 adopted the second progress report of the informal group, together with a change to the informal group's terms of reference to clearly provide for a

second phase of gtr development to incorporate the WorldSID 5<sup>th</sup> percentile female (ECE/TRANS/WP.29/2012/59).

At the 51<sup>st</sup> session of GRSP in May 2012, the informal group submitted an initial draft of part B of the gtr (GRSP-51-16).

**[further major procedural steps to be added as appropriate]**

In developing the gtr, the informal group has undertaken a significant program of work including:

- i) Review of previous work, particularly work undertaken on side impact protection by: the International Harmonised Research (IHRA) Side Impact Working Group; the European Enhanced Vehicle Safety Committee (EEVC); the Advanced Protection Systems (APROSYS) research program; and the United States of America, including its Final Regulatory Analysis to amend Federal Motor Vehicle Standard No.214 (FMVSS 214) to add an oblique pole test, published in 2007;
- ii) Conduct of extensive primary research, including crash tests programs conducted by Australia and Canada (including jointly), the United States of America, France, Japan and the Republic of Korea. This research has been the subject of detailed reporting in informal group meetings and is available on the informal group's website at <<https://www2.unece.org/wiki/pages/viewpage.action?pageId=3178630>>;
- iii) Consideration of work by the informal group on the harmonization of side impact dummies (see Section 4 below for more detail); and
- iv) Commissioning of research, through Australia, by the Monash University Accident Research Centre on the safety need, effectiveness and benefits and costs of the gtr<sup>1</sup>. **[this report is currently in draft; will be finalised upon receipt of IG comments]**

## 2. THE SAFETY CONCERN

The passive safety countermeasures expected to be used in vehicles to meet the requirements of the pole side impact gtr (most likely side curtain airbags and thorax airbags) are likely to reduce injury risk in pole side impact crashes as well as other side impact crashes, including high severity vehicle-to-vehicle side impact crashes and/or where head injury risks not simulated by current regulatory barrier tests occur as a result of geometric incompatibility between vehicles. It was recognised in framing the informal group's terms of reference that there may also be benefits in rollover crashes.

As a primary task, the informal group undertook a substantial amount of research on the number of occupant fatalities and serious injuries in pole side impacts, other side impacts and rollover crashes in contracting parties. Key data is presented in Table 1.

---

<sup>1</sup> Fitzharris et al, *Assessment of the need for, and the likely benefits of, enhanced side impact protection in the form of a Pole Side Impact Global Technical Regulation*, Monash University Accident Research Centre (2012). This report was largely based on Australian data, but with the cooperation of the UK Department for Transport, the Transport Research Laboratory and BASt also included analysis of UK and German data.

**[Following Table 1 is indicative table only – will be edited when data is finalised; the table will present a common year’s data for all countries, either 2009 or 2010]**

DRAFT

**Table 1: Fatalities and Injuries in Pole Side Impacts, Other Side Impacts and Rollovers**

Country	Year	Population	Total Road Fatalities	4-Wheeled Vehicle Occupant Fatalities	Pole Side Impact Fatalities	Other Side Impact Fatalities	Rollover Fatalities	Total Serious Injuries	4-Wheeled Vehicle Occupant Serious Injuries	Pole Side Impact Serious Injuries	Other Side Impact Serious Injuries	Rollover Serious Injuries
<b>US</b>	2009	307006550	33808	23885	1371	4872	8794	216769	166734	3813	45695	29894
% of total road fatalities/si					4.06%	14.41%	26.01%			1.76%	21.08%	13.79%
% of 4-wheeled occupant fatalities/si					5.74%	20.40%	36.82%			2.29%	27.41%	17.93%
Per 100,000			11.01	7.78	0.45	1.59	2.86	70.61	54.31	1.24	14.88	9.74
<b>Canada</b>	2009	32931956	2217	1513	60	215	203	11501	7671	161	720	835
% of total road fatalities/si					2.71%	9.70%	9.16%			1.40%	6.26%	7.26%
% of 4-wheeled occupant fatalities/si					3.97%	14.21%	13.42%			2.10%	9.39%	10.89%
Per 100,000			6.73	4.59	0.18	0.65	0.62	34.92		0.49	2.19	2.54
<b>Germany</b>	2009	82002356	4152	2318	396	632	53	68567	32443	2372	10893	921
% of total road fatalities/si					9.54%	15.22%	1.28%			3.46%	15.89%	1.34%
% of 4-wheeled occupant fatalities/si					17.08%	27.26%	2.29%			7.31%	33.58%	2.84%
Per 100,000			5.06	2.83	0.48	0.77	0.06	83.62	39.56	2.89	13.28	1.12
<b>France</b>	2009	64494000	4273	2399	181	333	201	33323	15191	325	1474	877
% of total road fatalities/si					4.24%	7.79%	4.70%			0.98%	4.42%	2.63%
% of 4-wheeled occupant fatalities/si					7.54%	13.88%	8.38%			2.14%	9.70%	5.77%
Per 100,000			6.63	3.72	0.28	0.52	0.31	51.67	23.55	0.50	2.29	1.36
<b>Great Britain</b>	2009	60000000	2222	1123	122	353	255	24690	10965	484	3769	1668
% of total road fatalities/si					5.49%	15.89%	11.48%			1.96%	15.27%	6.76%
% of 4-wheeled occupant fatalities/si					10.86%	31.43%	22.71%			4.41%	34.37%	15.21%
Per 100,000			3.70	1.87	0.20	0.59	0.43	41.15	18.28	0.81	6.28	2.78
<b>Netherlands</b>	2009	16485787	644	316	21	57	N/A	1513	415	22	79	N/A
% of total road fatalities/si					3.26%	8.85%				1.45%	5.22%	
% of 4-wheeled occupant fatalities/si					6.65%	18.04%				5.30%	19.04%	
Per 100,000			3.91	1.92	0.13	0.35		9.18		0.13	0.48	
<b>South Korea</b>	2009	48607000	5870	1978	204	1024	190	126378	251964	1985	148442	1987
% of total road fatalities/si					3.48%	17.44%	3.24%					
% of 4-wheeled occupant fatalities/si					10.31%	51.77%	9.61%			0.79%	58.91%	0.79%
Per 100,000			12.08	4.07	0.42	2.11	0.39		518.37	4.08	305.39	4.09
<b>Australia</b>	2006	20697880	1602	1095	161	172	284					
% of total road fatalities/si					10.05%	10.74%	17.73%					
% of 4-wheeled occupant fatalities/si					14.70%	15.71%	25.94%					
Per 100,000			7.74	5.29	0.78	0.83	1.37					

<b>Notes:</b>																			
si = serious injuries.																			
= Data not provided.																			
Different definition used (see country note).																			
Unless otherwise stated, 4-Wheeled Vehicle means all vehicles with at least 4-wheels																			
US - Serious injuries are incapacitating injuries.																			
Canada - Fatalities and serious injuries include estimates for two provinces; figures for pole side and other side impacts and rollovers are for M1 and N1 vehicles only. Percentages of occupant fatalities may therefore be understated.																			
Germany - Population is at 31 Dec 2008; seriously injured figures represent persons who were immediately taken to hospital for inpatient treatment (of at least 24 hours); figures for pole side and other side impacts and rollovers are for M1 vehicles only. Percentages of occupant fatalities may therefore be understated.																			
Great Britain - Figures do not include Northern Ireland; serious injury definition used: An injury for which a person is detained in hospital as an "in patient", or any of the following injuries whether or not they are detained in hospital: fractures, concussion, internal injuries, crushings, burns (excluding friction burns), severe cuts, severe general shock requiring medical treatment and injuries causing death 30 or more days after the accident. An injured casualty is recorded as seriously or slightly injured by the police on the basis of information available within a short time of the accident. This generally will not reflect the results of a medical examination, but may be influenced according to whether the casualty is hospitalised or not. Hospitalisation procedures will vary regionally.																			
Netherlands - Figures for pole side and other side impacts and rollovers are for M1 vehicles and N1 (delivery vans only). Percentages of occupant fatalities may therefore be understated. Figures are not available for rollovers.																			
South Korea - The definition for total serious injuries is more than 3 weeks treatment in hospital; the figures for 4-wheeled vehicle occupant serious injuries, pole and other side impact serious injuries and rollover injuries comprise all injuries.																			
Australia - fatality and AIS3+ injury data estimates are being obtained for Australia.																			

The data clearly demonstrates a major safety need. For example, in 2009, based on German, French, UK and Dutch figures, over 4,800 vehicle occupants were killed in side impacts in the EU (over 1,628 in pole side impacts; over 3,174 in other side impacts)<sup>2</sup>; 6,243 were killed in the US (1,371 in pole side impacts; 4, 872 in other side impacts); [XXX] were killed in Australia ([XXX in pole side impacts; XXX in other side impacts]) and 1,228 were killed in Korea (204 in pole side impacts; 1024 in other side impacts).

**[scope to update figures to 2010?].**

In the eight countries for which data is provided, in [2009] an average of over [5] percent of the road toll was killed in pole side impacts and over [12] percent of the road toll was killed in other side impacts, representing an average of [9] and [24] percent of vehicle occupant fatalities respectively.

Assessment of the scale of serious injuries arising from pole side impacts and other side impacts is more difficult as definitions of serious injury have varied between the countries providing data and the figures provided in Table 1 should accordingly be treated with caution.

However, analysis of UK CCIS data indicates that for every person killed in a pole side impact crash there are 3.1 MAIS3+ injuries or 25.5 MAIS1+ injuries and that for every person killed in a vehicle to vehicle side crash (by far the largest component of other side impacts) there are 2.7 MAIS3+ injuries or 123.2M AIS1+ injuries. **[source: weighted average in draft Fitzharris current Table 4.14].**

These figures indicate the very large numbers of serious injuries associated with side impacts reinforcing the safety need indicated by the fatality figures. Within this, it might be noted that pole side impacts are relatively rare as a crash type, but that they represent a disproportionately high level of fatalities and AIS3+ injuries indicating the lethal nature of pole side impacts.

Analysis of the cause of death or of injury types also indicates some clear patterns. For example, Fitzharris shows the following breakdown of fatalities in Australia in 2006: **[year to be checked]**

<sup>2</sup> APROSYS, *Advanced Side Impact Test Methods*, APROSYS Final Event (2009) indicated that there were approximately 10,000 car occupant fatalities in side impact crashes in Europe annually.

**Table 2: Coroner ruled causes of death for frontal, pole side impact and other side impact crashes for occupants of M1 / N1 vehicles combined<sup>3</sup>**

Coroner ruled cause of death	Frontal	PSI	Side – other
	% of 1272 occupants	% of 616 occupants	% of 795 occupants
Head	42.9%	54.2%	47.8%
Face	12.3%	9.9%	6.2%
Neck	8.3%	8.0%	9.4%
Thorax	42.1%	36.4%	43.0%
Abdominal/pelvic	22.4%	25.0%	25.9%
Spine	9.8%	7.5%	10.9%
Upper extremity	10.6%	11.0%	7.5%
Lower extremity	16.4%	11.0%	8.9%
External	4.8%	1.9%	1.3%
Multiple	36.7%	37.8%	36.1%
Injury not specified	2.8%	2.4%	2.3%

This shows head injuries as the major cause of death for both pole side impacts and other side impacts (and notably more prevalent than in frontal impacts), followed by thorax, abdominal/pelvic and spine injuries.

Analysis of AIS1+ injuries by Fitzharris using insurance claims data in the Australian state of Victoria for vehicle models dated 2000 or later (that is, after UN Regulation 95 was mandated) in the period 2000-2010 shows somewhat different patterns:

**Table 3. Injuries sustained by occupants of M1 passenger cars in near side impacts<sup>4</sup>**

AIS body region	AIS 1 +				AIS 3+			
	PSI		Vehicle		PSI		Vehicle	
	N	%	N	%	N	%	N	%
Head	121	57.1%	321	37.1%	25	11.8%	48	5.5%
Face	45	21.2%	70	8.1%	Nil	Nil	Nil	Nil
Neck	2	0.9%	3	0.3%	Nil	Nil	Nil	Nil
Thorax*	76	35.8%	276	31.9%	45	21.2%	75	8.7%

<sup>3</sup> [Draft of Fitzharris: Table 5.2, p62] Cause of death is specified by the Coroner in his/her 'Findings' following autopsy and / or other investigations including medical records and Medical Practitioner reporting of the cause of death. In the coding of deaths: 'Deaths resulting from external causes require the information surrounding the circumstances of injury to be reported. This includes the place of incident and activity. There is no time frame on when the injury occurred as long as there is a direct link between the injury or condition and the death' (p.121) 40. National Coronial Information Service. National Coronial Information System Coding Manual and User Guide, Version 4.0. Melbourne: Victorian Institute of Forensic Medicine, 2010. Cause of death was known for 1272 (84.5%) of frontal impact occupants, 795 side-other impact occupants (84.2%) and 616 (87%) pole side impact occupants; occupants can have multiple injuries specified as cause of death; note – where specified as 'multiple', no specific region is provided.

<sup>4</sup> [Draft of Fitzharris: Table 6.4, p85] The number of vehicle to vehicle crashes was 865 and pole side impacts 212.

Abdomen-pelvis	80	37.7%	281	32.5%	14	6.6%	17	2.0%
Spine	63	29.7%	286	33.1%	3	1.4%	6	0.7%
Upper extremity	107	50.5%	294	34.0%	2	0.9%	Nil	Nil
Lower extremity	67	31.6%	213	24.6%	18	8.5%	11	1.3%

Thorax injuries are the major cause of AIS3+ injury for both pole side impacts and other side impacts, followed by head, abdominal/pelvic and spine injuries (reflecting the fact that head injuries are more likely to be fatal).

**[Are there other sources with similar data? Is it possible to obtain a ratio of fatalities to AIS3+ head injuries?]**

These figures will be relevant in considering the injury criteria for the gtr set out below. However, the prevalence of head injury in both pole side impacts and other side impacts is also important in that it both underlines safety need and is relevant to assessment of benefits. In Australia, for example, the most recent value of statistical life is AUD\$4.9 million (US\$5.1 million)<sup>5</sup>. Based on insurance claims data, it has been estimated that the societal and lifetime care cost of severe brain injury (taken to be AIS4+) at AUD\$4.8m and moderate brain injury (taken to be AIS3) at\$3.7 million<sup>6</sup>.

Category 2 Vehicles

In general the majority of data provided in Table 1 relates either to Category 1 vehicles or has not been disaggregated by vehicle category. This makes assessment of safety need more difficult for Category 2 vehicles than it is for Category 1.

In the United States of America, the regulation impact statement, published in support of the implementation of the oblique pole side impact test in FMVSS 214 in 2007, aggregated data for Category 1 and Category 2 vehicles. The test applies to Category 1 and Category 2 vehicles (which commonly includes pickups), with some exceptions.

Australia presented data to the informal group that indicated that as a proportion of N1 vehicle fatalities, pole side impacts and other side impacts were approximately as common as they were among M1 vehicles. However, the large majority of fatalities and serious injuries in N1 vehicles in Australia involve passenger derived utility vehicles, 4X2 pick-ups/cab chassis utility vehicles and 4X4 pick-ups/cab chassis utility vehicles.

These vehicles are increasingly being used as passenger vehicles and in many cases are exempt from the requirements of UN Regulation 95 as their seating reference height is over 700mm.

<sup>5</sup> As at 14 November 2012

<sup>6</sup> [reference to be provided from Fitzharris]



The Australian situation highlights the fact that the composition of vehicle fleets, and therefore safety need, in Category 2 is highly variable from country to country. This matter will be considered further when the applicability of the gtr is considered in Section 5 below.

### Electronic Stability Control

The informal group considered the extent to which the safety concern associated with pole side impacts and other side impacts would be addressed by the advent of Electronic Stability Control (ESC).

In this regard it is noted that the fitment of ESC to vehicles has increased significantly recently and in Europe will be mandatory for almost all Category 1, 1.2 and 2 vehicles by 2013 **[other countries/regions?]**. The group also considered research presented by BAST, NHTSA and Monash University Research Centre, showing the following crash reductions:

BAST – **[about 40 percent of single vehicle crashes];**

NHTSA - single vehicle run-off-crashes: 35 percent for passenger cars; 67 percent for sports utility vehicles (preventing 41 percent of fatal crashes and 35 percent of serious injuries)

MUARC: single vehicle crash reductions: 24 percent for passenger cars; 54 percent for four wheel drive M1 vehicles and 45 percent for N1 vehicles.

These are significant figures, but even where ESC is fitted or will be fitted, this will still leave a large proportion of pole side impacts to be addressed. Moreover, ESC is much less effective in multi-vehicle crashes which make up the majority of all side impacts. MUARC's recent research indicates negligible or no benefits<sup>7</sup>.

NHTSA's regulation impact statement for the addition of the pole side impact test to FMVSS 214 assumed 100 percent implementation of ESC while still showing major benefits. Preliminary calculations by MUARC for Australia also show major benefits, while assuming 100 percent implementation of ESC.

The informal group also considered the potential for other active safety systems, such as collision avoidance systems to reduce the fatalities and injuries occurring in side impacts. The benefits from such systems are largely yet to be established, while the proposed gtr responds to a major current safety need. Nevertheless it will be possible for Contracting Parties to consider developments in active safety when considering adoption of the gtr into domestic regulation.

**[OICA text on ESC to be considered. MUARC report will also provide adjusted effectiveness rates for ESC allowing, eg, for the fact that ESC equipped vehicles are driven by the safest drivers. This may also need to be considered.]**

### Rollover Crashes

---

7 [reference]

In Table 1 countries provided data indicating that a high proportion of road fatalities and injuries occurred in rollover crashes. While it is reasonable to assume that a portion of rollover fatalities and injuries would be avoided by the implementation of the gtr, it is not clear to what extent rollovers are associated with pole side and other side impacts; nor to what extent countermeasures for the gtr will address them. The main benefit of pole side impact countermeasures in protecting vehicle occupants in a rollover is by prevention of ejection through side windows. This may only be effective in a subset of crashes as it is necessary for sensors to detect rollovers without side impact (unless the rollover is initiated by a side impact) and for the deployed curtain to cover the window area and remain in place sufficiently long to prevent ejection.

It might also be noted that ESC is likely to be at its most effective in countering rollovers, particularly among N1 vehicles. It will be for Contracting Parties to determine the extent the gtr will address fatalities and injuries in rollover crashes, in light of their own circumstances, when considering adoption of the gtr.

### 3. EXISTING REGULATIONS AND INTERNATIONAL VOLUNTARY STANDARDS

As indicated in Table 4, test procedures for pole side impact tests – either in regulation or in voluntary standards – are highly variable internationally. **[should we also cover side impact?]**

**Table 4: Current Pole Test Procedures**

	<b>Impact Angle</b>	<b>Impact Velocity</b>	<b>Dummy</b>	<b>Comments</b>
<b>Regulatory</b>				
US FMVSS 201	90°	29 km/h	SID H3 (50 <sup>th</sup> percentile male)	<b>[phasing/applicability]</b>
US FMVSS 214 Advanced	75°	26-32 km/h	ES-2RE (50 <sup>th</sup> percentile male)	<b>[phasing/applicability]</b>
			SID-IIs (5 <sup>th</sup> percentile female)	<b>[phasing/applicability]</b>
<b>Voluntary Standards - NCAPs</b>				
U.S. NCAP	75°	32 km/h	SID-IIs (5 <sup>th</sup> percentile female)	
Euro NCAP	90°	29 km/h	ES-2 (50 <sup>th</sup> percentile male)	
KNCAP	90°	29 km/h	ES-2 (50 <sup>th</sup> percentile male)	
ANCAP	90°	29 km/h	ES-2 (50 <sup>th</sup> percentile male)	
JNCAP	No test			
Latin NCAP	No test			
China NCAP	<b>[???</b>			

As this table indicates, the United States of America is the only country which has implemented a regulatory pole side impact standard. It did this first with the perpendicular test requirement in FMVSS 201 (as an alternative to upper interior headform testing where head protecting airbags are fitted) and is currently phasing in an oblique test requirement in FMVSS 214. In Europe and a number of countries outside Europe, pole side impact tests are conducted by New Car Assessment Programs (NCAPs), although whether and how NCAPs conduct tests vary. In many member countries of WP.29 neither regulatory nor voluntary pole side impact tests operate.

#### 4. WORLDSID

##### Biofidelity

The WorldSID was developed by government and industry organisations and has demonstrated improved overall biofidelity when compared to the current test tools used in side impact testing. The WorldSID 50<sup>th</sup> percentile male's expanded capability includes an improved shoulder range of motion and displacement measurement, more human-like shoulder and thorax motion, improved external oblique biofidelic response, and abdominal displacement measurement capability.

Currently the EuroSID 2 (ES-2) 50<sup>th</sup> percentile male is used in pole side impact testing by a number of NCAPs, while the ES-2RE 50<sup>th</sup> percentile male is specified for use in the pole side impact test in FMVSS 214. However, both the WorldSID taskforce and NHTSA have conducted research that has shown the WorldSID 50<sup>th</sup> percentile male to be considerably more biofidelic than both ES-2 and ES-2RE. On the 10 point ISO TR9790 biofidelity rating scale, the WorldSID taskforce found the WorldSID 50<sup>th</sup> percentile male to have a rating of 8.0, the ES-2 50<sup>th</sup> percentile male a rating of 4.7, and the ES-2RE 50<sup>th</sup> percentile male a rating of 4.2. Furthermore, the shoulder of the ES-2 dummy has a substantially lower biofidelity rating than the WorldSID 50<sup>th</sup> percentile male. Shoulder design substantially affects dummy response during pole and side airbag interactions, while biofidelity is extremely important in narrow object crashes as the margins between minor and serious or fatal injury are relatively small.

The informal group regards the WorldSID as having major benefits as a test tool that should translate into superior countermeasures providing real world protection. The informal group unequivocally recommends that the gtr use WorldSID as the test tool.

##### Preparing WorldSID for use as a test tool

AC.3 agreed to the establishment of an informal group on harmonization of side impact dummies chaired by the United States of America at the 151st meeting of WP.29, with the primary focus of the informal group being to ready WorldSID for use as a test tool. This coincided with AC.3's agreement to the establishment of the informal group on the gtr and, as intended by AC.3, the two groups have worked in close conjunction with each other.

##### The Two Phase Approach

Drawings and associated documentation for the WorldSID 50<sup>th</sup> percentile male are expected to be available for citation in the gtr in 2013 whereas the timetable for the WorldSID 5<sup>th</sup> percentile female to reach this stage of development appears likely to extend to 2014 or beyond.

As some contracting parties indicated a desire to implement the gtr using the WorldSID 50<sup>th</sup> percentile male as soon as this was practical, there was significant discussion in the informal group over whether and how to address small occupant protection in the gtr, while recognising that it would not be possible for the United States of America to agree to a gtr that was in any way less stringent than FMVSS 214. FMVSS 214 currently includes test procedures for both the ES2-RE 50<sup>th</sup> percentile male and SID-IIs 5th percentile female in the oblique angle pole side impact test.

The informal group also noted that NHTSA estimated that small occupants (5'4" or less) represented 25 percent of all near side occupant fatalities and serious injuries in side impacts in the US in the period 2002-04. In calculating the benefits for the amendment to FMVSS 214 to include a pole side impact test, NHTSA estimated that the use of the SID-IIs 5th percentile female would save an additional 78 lives a year (PSI-01-10).

As a consequence the informal group agreed to a two phase approach to the gtr subsequently endorsed by GRSP and AC.3, to enable contracting parties to implement a pole side impact standard utilising the WorldSID 50<sup>th</sup> percentile male and, if warranted, subsequently implement a pole side impact standard utilising the WorldSID 5<sup>th</sup> percentile female.

As noted in the Introduction and Procedural Background (paragraph [XX]), the terms of reference for the informal group were amended to provide for a second phase of gtr development to incorporate the WorldSID 5<sup>th</sup> percentile female.

Part B of this gtr provides for the second phase of work by including place marks for future text on the WorldSID 5<sup>th</sup> percentile female; and explicit provision for contracting parties to apply any pre-existing domestic pole side impact requirements for 5<sup>th</sup> percentile female side impact dummies, prior to availability of the WorldSID 5<sup>th</sup> percentile female.

## 5. KEY ELEMENTS OF THE GTR

### Application/Scope

The application of the requirements of this gtr refers, to the extent possible, to the revised vehicle classification and definitions outlined in the 1998 Global Agreement Special Resolution No. 1 (S.R.1) concerning the common definitions of vehicle categories, masses and dimensions.

The informal group agreed to recommend a wide application in the gtr in terms of vehicle categories; specifically, that it apply to all Category 1-1 vehicles; Category 1-2 vehicles with a Gross Vehicle Mass of up to 4,500 kg; and Category 2 vehicles with a Gross Vehicle Mass of up to 4,500 kg.

This maximises the ability of jurisdictions to effectively address regional differences in their vehicle fleets. However, it is important to note that Contracting Parties have the discretion to exclude particular vehicle types, for which there is insufficient national safety need to justify regulation or for which the test requirement in the gtr is not feasible. If a Contracting Party determines that its domestic regulatory scheme and/or safety needs are such that full applicability is inappropriate, it may limit domestic implementation of the gtr to certain vehicle categories or mass limits. The Contracting Party could also decide to phase-in the requirements for certain vehicles. To make this clear, a footnote was added to the Application/Scope section of Part B to make it clear that Contracting Parties can decide to limit the applicability of the regulation. This approach recognizes

that niche vehicles that are unique to a Contracting Party would best be addressed by that jurisdiction, without affecting the ability or need for other Contracting Parties to regulate the vehicles. When a Contracting Party proposes to adopt the gtr into its domestic regulations, it is expected that the Contracting Party will provide reasonable justification concerning the application of the regulation.

Accident statistics from some regions indicate certain vehicles, particularly cargo vehicles such as 1 box vans are rarely involved in side impacts with rigid narrow objects such as poles and trees. Furthermore, many of these vehicles also have high seating positions which are likely to reduce the exposure of occupants to injurious head and thorax impact loadings in other side impact crashes. In vehicle-to-vehicle side impact crashes the most likely sources of struck side occupant head injuries are head contact with the bonnet/hood of a striking vehicle, head contact with the vehicle interior (for example, the b-pillar) or head-to-head contact with an adjacent occupant seated in the same seat row. Struck side occupant thorax injuries in vehicle-to-vehicle side impacts are most likely to be caused by rapid loading of the occupant thorax by an intruding b-pillar, armrest or door trim. Occupants of vehicles with high seating reference points would be expected (by virtue of their seating height) to have reduced exposure to head-to-striking vehicle bonnet/hood contacts, as well as less exposure to high vehicle interior (such as the b-pillar or armrest) intrusion velocities at the occupant head and thorax seating level in vehicle-to-vehicle side impacts.

It is also understood that vans, mini-buses and mini-trucks are typically driven and used differently to normal passenger cars and pick-ups. The way in which these vans, mini-buses and mini-trucks are driven and the purposes for which they are used will influence the likelihood (risk) of these vehicles being involved in fatal and/or serious pole side impact and other side impact crashes.

The gtr informal group therefore decided to include criteria Contracting Parties may use, if warranted by national safety need data, to exempt certain Category 1-2 and Category 2 vehicles from the requirements of the gtr at the time of implementation in domestic regulation. These vehicles are robustly characterized as Category 1-2 and Category 2 vehicles where the angle alpha ( $\alpha$ ), measured rearwards from the centre of the front axle to the R-point of the driver's seat is at least 22 degrees; and the ratio between the distance from the drivers' R-point to the centre of the rear axle (L101-L114) and the centre of the front axle and the drivers' R-point (L114) is greater than or equal to 1.3.

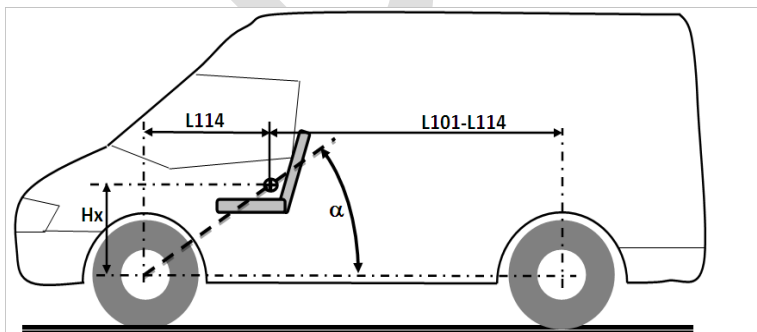

L114 and L101 based on SAE J-1100. HX not standardized.

OICA made a presentation (PSI-07-08) at the 7th meeting of the informal group detailing vehicle dimensions and showing how these specific measurements can accurately define vehicle types. An  $\alpha$

of at least 22 degrees was proposed because it would enable the exemption of mini-buses, vans and mini-trucks with high seating positions (i.e. high seating reference points) and/or where the occupant is seated over the front axle, without exempting pick-ups. A ratio between the distance from the drivers' R-point to the centre of the rear axle (L101-L114) and the centre of the front axle and the drivers R-point (L114) greater than or equal to 1.3 was proposed because it characterises vehicles which have significant cargo space and a centre of gravity considerably rearward of the drivers' R-point.

#### Angle of Impact

The informal group considered three different impact configurations for possible use in the gtr test procedure, namely:

- i) the oblique angle currently used in the FMVSS 214 pole test, with the pole aligned with the centre of gravity of the dummy head;
- ii) the perpendicular angle used by a number of NCAPs in their pole tests, including EuroNCAP and Australian NCAP, with pole aligned with the centre of gravity of the dummy head; and
- iii) a perpendicular test procedure with the location of the pole offset 100 mm forward of the head centre of gravity.

The informal group discounted configuration (iii) above at an early stage as an unnecessary departure from existing procedures, with no demonstrated benefit, at a time when major change would already be required to incorporate WorldSID into a test procedure.

This left the informal group to select the most appropriate configuration from a perpendicular and an oblique angle impact, aligned with the head centre of gravity. There were two primary factors in its consideration of this matter: the angle of impact in real world pole side impacts and the outcome being sought.

The oblique angle test emerged as the recommended test angle having regard to both criteria. US, German and Australian data indicated that pole side crashes occurred at predominantly oblique angles (earlier EEVC analysis indicating that 90 degree angle crashes were more common was recorded within a range of plus or minus 15 degrees and therefore not contradictory).

In all other respects evidence favoured an oblique angle test over a perpendicular angle test or was, at least, neutral: the oblique angle test was shown to load the WorldSID thorax better than a perpendicular test; manufacturers indicated that the oblique test encouraged more robust sensors; previous concerns regarding repeatability were shown to be unfounded; and data was presented suggesting oblique angle impacts were likely to become more common for vehicles fitted with ESC.

Most importantly, an oblique angle test was also expected to produce higher head injury values in testing, drive an extended coverage area by head protecting curtain airbags and be less sensitive to seat position and seat back angle<sup>8</sup>.

---

<sup>8</sup> [references to be provided]

As reflection of a number (but not all) of these points, the regulatory impact assessment for the amendment to introduce an oblique angle pole side impact test in FMVSS 214 calculated that an oblique angle test would save at least 87 more lives a year than a perpendicular angle test.

### Test Speed

Apart from one exception described below, the gtr provides that the “test vehicle...shall be impacted at any speed up to and including 32 km/h, with a stationary pole.” This wording provides the flexibility for both self-certification and type approval authorities to adopt approaches in implementing the gtr that are consistent with their normal practice. For example FMVSS 214 currently allows vehicles to be tested at a speed between 26 and 32 km/h and this approach will be able to be maintained under the gtr. Type approval authorities will, on the other hand, be able to specify a single test speed of 32 km/h.

There was some discussion within the informal group about whether type approval authorities could determine test speeds from within a range. However, it was recognised that this could potentially mean vehicle manufacturers being required to do many different tests at different speeds in type approval markets. In contrast, to address the speed range requirements of self-certification authorities, manufacturers can use appropriate tools including simulation models to satisfy themselves they meet all potential test speeds.

The informal group agreed that it would be appropriate for type approval authorities to set the test speed at 32 km/h with a tolerance of plus or minus 1 km/h as this would allow a reasonable margin either side of the maximum test speed at which contracting parties may require a vehicle to meet the gtr. It should be noted that this tolerance would not necessarily require manufacturers to obtain type approval for test speeds greater than 32 km/h. It simply means test speeds of 32 km/h plus or minus 1 km/h would be accepted for type approval purposes. Where test speed can be controlled more accurately, for example to within plus or minus 0.5 km/h as has been required of EuroNCAP test facilities, type approval tests could consistently be conducted within the allowable range, without manufacturers being required to demonstrate compliance in excess of the 32 km/h maximum test speed of the gtr.

### *Exception for narrow vehicles*

The exception from the requirement that the “test vehicle...shall be impacted at any speed up to and including 32 km/h, with a stationary pole,” is set in Annex 1, paragraph 7.2, of Part B and reads:

The maximum test velocity may be reduced to 26 km/h for vehicles with a width of 1.50 m or less. Contracting parties selecting this option shall notify the Secretary General in writing when submitting the notification required by section 7.2 of the Agreement Concerning the Establishing of Global Technical Regulations for Wheeled Vehicles, Equipment and Parts Which Can Be Fitted.

This provision was agreed by the informal group in response to a request from Japan to provide a temporary concession for Kei-cars in the gtr. In agreeing to this concession the informal group took the view that it was better for Kei-cars to be brought clearly within the ambit of the gtr than be subject to exclusions to the gtr made in domestic law (an alternative Japan could otherwise have adopted). In this respect the informal group was mindful that Kei-cars or narrow cars are being manufactured in other markets and are likely to become increasingly prevalent in the global market.

Japan made a number of points in support of its case. In PSI-05-06, for example, Japan indicated that Kei-cars (which have a width of less than 1.50 m and are categorized as small cars), tend to have speeds in single vehicle crashes lower than standard-size cars. In addition, a survey on pole side impact accidents in Japan also showed that the danger recognition speed in single vehicle crashes of Kei-cars is lower than standard-size cars by about 5 to 7 km/h around the 70th percentile range. The 26 km/h test speed covers the Kei-car accidents at a rate equivalent to that of 32 km/h for the other vehicles.

Moreover, in the case of narrow vehicles with a width of 1.50 m or less, since the distance between door outer panel and seat centre is short, it is difficult to meet the injury criteria for the crash speed of 32 km/h with current crash safety technologies.

Japan however stressed that the exemption should be removed (that is, narrow vehicles should be tested at a speed of 32 km/h) when it is technically viable for narrow cars to meet all requirements of the gtr.

For this reason, the exemption should be kept under regular review, including in the second phase.

In agreeing the concession, the informal group also agreed that it would be a matter for each Contracting Party to determine whether Kei-cars tested at 26 km/h could be admitted to its market. It was noted that this principle could be reflected in transposition of the gtr into UN Regulation.

#### Injury Criteria

In formulating injury criteria for the WorldSID 50<sup>th</sup> percentile male in this gtr, the informal group had regard to the injury risk curves agreed by ISO Working Group 6 (ISO WG6)<sup>9</sup> for the shoulder, thorax, abdomen and pelvis adjusted for a 45-year-old male (WS-08-04; WS-09-07).

The informal group also had regard to the comparatively young age profile of vehicle occupants in pole side impacts (various studies suggested a median age of about 24 years of age), although it was noted that the age profile of vehicle occupants in other side impacts was older (with a median age of about 45 years of age).<sup>10</sup> Setting injury criteria on the basis of injury curves adjusted for a 45-year-old provides greater protection where the demographic associated with a particular crash type is younger (and more physically robust). This should produce additional road safety benefits and be considered in benefit calculations.

The informal group also noted that FMVSS 214 includes four injury criteria for the ES-2RE 50<sup>th</sup> percentile male (45-year old) in the pole side impact test, namely: head injury, thorax injury, abdominal force and pelvis injury.<sup>11</sup>

#### *Head Injury*

---

9 ISO/SC12/TC22/WG6 (Injury criteria), which worked in conjunction with the ACEA-Dummy Task Force.

10 In the Australian state of Victoria in the period 1999 to 2010, 77 percent of all fatalities in pole side impacts were aged under 45, while 52 percent of all fatalities in vehicle to vehicle side impacts were aged under 45.

11 Head injury (HIC36  $\leq$  1000  $\approx$  50% AIS3+), thorax injury (rib deflection  $\leq$  44mm  $\approx$  50% AIS3+), abdominal force (2.5 kN  $\approx$  50% AIS3+) and pelvis injury ((pubic force  $\leq$  6kN  $\approx$  50% AIS3+).



As noted earlier, a very high proportion of fatalities and AIS3+ injuries in pole side impacts and other side impacts are caused by head injuries, predominantly brain injuries. The informal group determined that the head protection performance should be based on the Head Injury Criterion (HIC) 36, given the ability of the HIC to estimate the risk of serious to fatal head injury in motor vehicle crashes.

The informal group agreed that the HIC36 must not exceed 1000, which is equivalent to approximately a 50 percent risk of AIS3+ head injury adjusted for a 45-year-old male.

The informal group also considered the Brain Injury Criterion (BRIC) currently being developed by the United States of America. The BRIC specifically addresses injuries caused through rotational acceleration of the brain and has significant potential as an injury criterion, especially as there is some evidence in the field of cases where the HIC is thought to have been relatively low but serious brain injury has still occurred. However, the BRIC still requires significant development and evaluation. The informal group agreed that progress on the BRIC and possible incorporation in the gtr should be considered as part of the second phase. Part B includes a place mark for a future BRIC requirement.

*[Shoulder Performance – requirement and text to be determined]*

#### *Thorax Performance*

A high proportion of fatalities and AIS3+ injuries in pole side impacts and other side impacts are also caused by thorax injuries.

The informal group agreed that the maximum thorax rib deflection must not exceed [55] mm, which is equivalent to approximately 50 percent risk of AIS3+ thorax injury for a 45-year-old male.

There was initially some concern that using a thorax injury risk curve for a 45 year old to set this limit may not guarantee appropriate protection for older occupants, especially given many countries now have ageing populations. However, it was noted that accidents statistics from a number of countries (including Australia, Germany, the UK, and the United States of America) show a substantial majority of occupants killed or seriously injured in pole side impact crashes to be aged less than or equal to 45. In contrast, accident statistics from these same countries show a substantial proportion of occupants killed or seriously injured in other side impact crashes are aged over 45. The thorax protection needs of older occupants in particular may therefore be more appropriately addressed by updating mobile deformable barrier to vehicle side impact requirements. For example, a thorax injury risk curve for a 67 year old (the average age of the cadavers used in tests from which injury risk curves are derived) may appropriately be used to set the thorax rib deflection limit if mobile deformable barrier side impact regulations are reviewed.

The informal group also considered including a peak thorax viscous criterion, however at this stage ISO WG 6 has not been able to construct an injury risk curve with an acceptable quality index. Progress in developing a peak thorax viscous criterion could be considered further in the second phase.

The gtr includes reference to **[Addendum [XX]]** of the Mutual Resolution. This Addendum includes the drawings and user manual for the WorldSID 50<sup>th</sup> male Build Level F. This includes 2-dimensional

rib deflection measurement (2D-IRTRACC) despite the thorax injury criterion for the gtr at this stage including a 1-dimensional deflection limit. This is because the thorax injury risk curves developed to date are 1-dimensional injury risk curves, suitable for side impact tests in which the dummy thorax is loaded in a predominantly lateral direction (for example, 75 degree oblique pole side impact tests). The use of 2D-IRTRACC allows for two dimensional thorax (and abdominal) deflection based injury criteria to be used in the future without requiring a change to the dummy rib deflection measurement system.

#### *Abdominal/Pelvic Performance*

A smaller, yet still significant, proportion of fatalities and AIS 3+ injuries in pole side impacts and other side impacts are caused by abdominal/pelvic injuries.

The abdominal ribs of the WorldSID 50<sup>th</sup> percentile adult male dummy partially overlap the floating thorax ribs of a mid-size adult male. This means increased loading of the WorldSID 50<sup>th</sup> male abdominal ribs would be expected to increase the risk of both AIS 3+ thorax and AIS 3+ abdominal injuries. For this reason ISO WG6 had constructed a thorax injury risk curve for a 45 year old male as a function of the maximum thorax and abdominal rib deflection. ISO WG6 determined the 50 percent AIS 3+ thorax injury risk threshold value as a function of the maximum thorax or abdominal rib deflection to be 58 mm. ISO WG6 determined the 50 percent AIS 3+ abdominal injury risk threshold value as a function of the maximum abdominal rib deflection to be [92 mm]. Dummy ribs cannot physically deflect this much. To protect both the thorax and the abdomen, the informal group therefore agreed that the maximum abdominal rib deflection must not exceed [58] mm.

To protect the pelvis, the informal group agreed that the maximum pubic symphysis force must not exceed 3.36 kN, which is equivalent to approximately a 50 percent risk of AIS3+ pelvic injury for a 45-year-old male.

The informal group also agreed that the lower spine acceleration must not exceed 75g ( $1g = \text{the acceleration due to gravity} = 9.81 \text{ m/s}^2$ ), except for intervals whose cumulative duration is not more than 3ms.

While ISO WG6 preferred abdominal rib deflection as the best predictor of abdominal injury risk, the lower spine acceleration criterion has also been included because it may in some specific circumstances detect severe lower thorax and abdominal loadings a 1-dimensional abdominal rib deflection criterion may not. This concern may be addressed in the future by the introduction of 2-dimensional rib deflection criteria, but in the meantime this acceleration based criterion is expected to detect unusual loadings, such as excessive airbag loadings from behind the dummy, without requiring vehicle design changes for normal load conditions.

This concern arose from analysis of a pole side impact test conducted by Australia and Canada using RibEye ([PSI-06-13](#)).

It was generally noted that the differences between the theoretical IRTRACC deflection and the peak middle LED y-axis displacement (that is, the WorldSID half thorax compression) were in most cases small, especially for oblique pole tests. However, it was noted that in one test, the loading of the thorax/abdomen from behind by the seat mounted side airbag had caused substantial forward rotation of the ribs. As a result, the theoretical IRTRACC deflection in this test was considerably less

than the peak middle RibEye LED y-axis deflection. However, the 3ms lower spine acceleration was well over 75g (120+ g) and this was the only test to produce a 3ms lower spine acceleration in excess of 75g.

Other pole side impact tests jointly conducted by Australia/Transport Canada show that at the least a 60 mm maximum abdominal rib deflection would typically be required under normal vehicle-to-pole side impact dummy load conditions to generate a 3ms lower spine acceleration in excess of 75g.

The informal group also considered including a peak abdominal viscous criterion, however at this stage ISO WG6 has not been able to construct an injury curve with an acceptable quality index. Progress in developing a peak abdominal viscous criterion could be considered further in the second phase.

***[Sacro-Iliac – Steve Ridella to provide words]***

#### Seat Adjustment and Installation Requirements

**[approach and wording to be determined]**

#### Impact Alignment Tolerance

[The informal group considered research undertaken by Australia (PSI-05-10) which showed that changing the pole impact alignment by 100mm can make as much difference to the WorldSID 50<sup>th</sup> peak rib deflection responses as changing the angle of impact by 15 degrees.

The FMVSS 214 and EuroNCAP pole side impact protocols include a  $\pm 38$ mm impact alignment tolerance (making a 76mm wide allowable impact zone). However, analysis of actual impact alignments in Australian and Canadian pole side impact research tests, Australian NCAP pole tests and US NCAP pole tests indicated that it is feasible to consistently produce an actual impact alignment within 15mm of the target impact alignment.

The informal group accordingly agreed to a  $\pm 25$  mm impact alignment tolerance. This will ensure type approvals are issued based on tests of comparable stringency.] **[Awaiting US views]**

#### Electrical Safety

The informal group noted that AC.3 had agreed to a proposal for a gtr on electric vehicle safety and that an informal group had been established to progress the gtr. It was decided to leave electrical vehicle safety requirements out of the draft regulatory text for the pole side impact gtr for now, pending a possible future proposal from appropriate experts. Progress on this matter can be considered as part of the second phase.

#### Unlocking of Door

There was some discussion within the Informal Group whether there should be a requirement in the gtr for the doors to be unlocked after impact. It was agreed that this matter could be considered further if and when a workable proposal was able to be developed in conjunction with a safety need case. This matter can be considered further as part of the second phase.

## 6. REGULATORY IMPACT AND ECONOMIC EFFECTIVENESS

**[Awaiting finalisation of MUARC report for drafting]**

## 7. SUMMARY OF ISSUES TO BE CONSIDERED IN THE SECOND PHASE

In the above text, a number of issues have been identified for consideration in the second phase. For ease of reference, these can be briefly summarised as:

- i) Incorporation of WorldSID 5<sup>th</sup> percentile female in the gtr;
- ii) Review of test speed exemption for narrow vehicles;
- iii) Progress on the Brain Injury Criterion (BRIC) and possible incorporation in the gtr;
- iv) Progress in developing a peak thorax viscous criterion;
- v) Progress in developing a peak abdominal viscous criterion;
- vi) Electrical safety requirements; and
- vii) A possible requirement in the gtr for the doors to be unlocked after impact.

## 8. LEADTIME

It should be noted that the requirements of the draft gtr are generally more stringent than existing legislation or even voluntary standards at the time of adoption of the gtr. In addition, many countries do not yet have pole side impact requirements under either regulation or voluntary standards.

It is therefore recommended that Contracting Parties implementing this gtr allow adequate lead time before full mandatory application, considering the necessary vehicle development time and product lifecycle.