



Task Force – Bumper Test Area: EC study update

Presented by Jolyon Carroll
Senior Researcher – 18 March 2013



Agenda

EC study to support Task Force

- 1 Update...
- 2 Understanding of issue
- 3 Collation of previous research – e.g. Euro NCAP
- 4 Vehicle geometry
- 5 Other items – test work, etc.

2nd meeting: Task Force – Bumper Test Area

- At the 2nd meeting concerning modification of the legform test procedure TRL presented an update for the EC study
 - Presented contents of a draft service request
 - Project objectives matching the activities of this group

- TRL have now won that contract

Context for group and EC study

Regulation (EC) No 78/2009 – type approval with regard to protection of pedestrians

- Technical prescription of test area in Commission Regulation (EC) 631/2009
- Bumper corner =
... the vehicle's point of contact with a vertical plane which makes an angle of 60° with the vertical longitudinal plane of the vehicle and is tangential to the outer surface of the bumper.

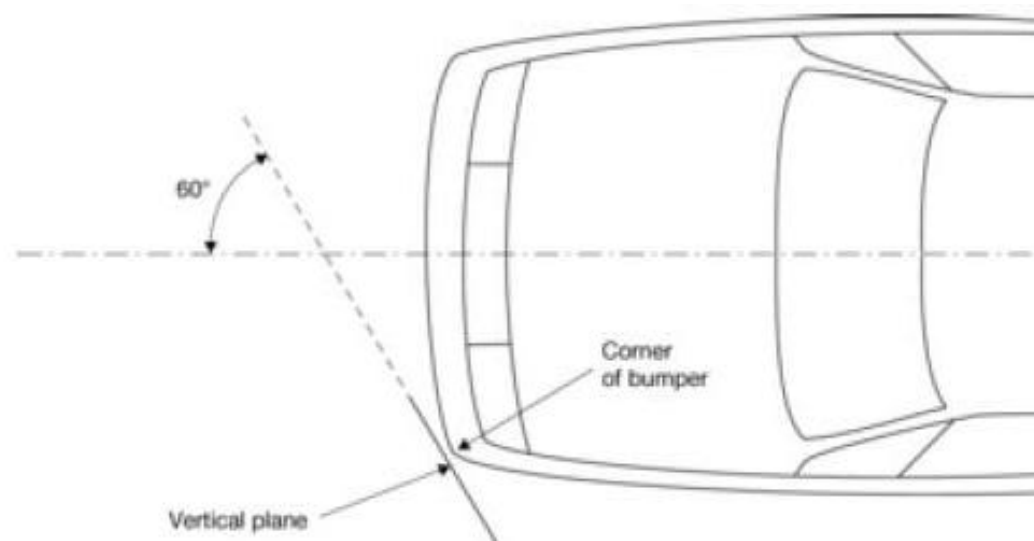

Context for group and EC study

- UN Global Technical Regulation (GTR) No. 9
 - Text on bumper area not altered in current draft phase 2 amendment
 - Amended GTR would use the same definition as Commission Regulation
 - Request for clarification on bumper test area (OICA)
- Task Force – Bumper Test Area
 - Set-up to consider the bumper corner definition

Context for group and EC study

- Subject of EC study:
 - To investigate whether the 60 degree plane definition could be adjusted in a sensible and cost-effective way to define the corners of the bumper as being close to the side of the vehicle

- Previously given a summary of project tasks
- Now have initial updates regarding preliminary progress...
 - Some tasks are progressing well
 - Others are due to start soon (e.g. testing, accident case review)

Understanding of issue: Why did EEVC WG10 change bumper corner definition to 60° plane?

- Before or at the start of the current project, TRL was aware of:
 - Change from 45° to 60° occurred between draft test procedures in ERGA document of 1985 and those in TRRL (now TRL) report of 1991
 - TRL proposal to EEVC WG17 in 2002 to change to 45°
 - WG17 decided that further work was necessary before this could be accepted
 - Another meeting document referred to UN Reg. 42, FMVSS581 and CMVSS581 in connection with this item
 - Reduced bumper test area observed in cars tested for Euro NCAP
 - Proposal by Oliver Zander (BAST) to modify the Bumper Test Area (document GTR9-2-03, especially slide 3)
 - This referenced "Personal correspondence between B. Hardy (TRL) and O. Zander (BAST), July 2009" {thank you for the reminder, Oliver}

Understanding of issue: Why did EEVC WG10 change bumper corner definition to 60° plane?

- TRL has now examined the papers it holds relating to EEVC WG10, especially:
 - Minutes of EEVC WG10 meetings
 - Minutes of meetings of those members participating in an EC contract
 - Draft pedestrian test procedures
 - Reports to the EC by the contractors
 - Papers by the contractors to the 1991 ESV conference

Understanding of issue: Why did EEVC WG10 change bumper corner definition to 60° plane?

- The change in bumper corner definition from using a 45° plane to using a 60° plane seems to have occurred at the 22-23 October 1990 meeting of WG10
 - An 'EC Contractors' meeting on 4 Sept 1990 referred to an urgently required paper on the definition of test areas
 - A "Discussion paper on the determination of the areas of a car to be tested for pedestrian safety", undated, presumably by the chairman (John Harris), still used a plane at 45° to define the bumper corner
 - At the 22-23 October 1990 meeting, according to the minutes, John Harris distributed a "draft proposal for EEC type-approval, specifications, tests and conformity of production". Unfortunately, TRL's WG10 files didn't include a copy.
 - The meeting proceeded to go through this document paragraph-by-paragraph.

Understanding of issue: Why did EEVC WG10 change bumper corner definition to 60° plane?

- In relation to the definition of the corners of the bumper the minutes simply state:
 - “Geneva reg. 42 uses 60 degrees to C/L to define the corners of the bumper.”
 - This must have been a busy meeting, being the last meeting before the test procedures were submitted to the EC, so the very limited discussion recorded in the minutes should not be surprising

Understanding of issue: Why did EEVC WG10 change bumper corner definition to 60° plane?

- Subsequent test procedures used a 60° plane:
 - Report by TRRL to the UK Department of Transport, July 1991
 - "Summary of the work of the consortium developing test methods to evaluate the protection afforded to pedestrians by cars (including test proposals). Chairman's report under Contract No. ETD/89/7750/M1/28 to the European Commission." "Revised 17 December 1991"

- Concerns about the capability of the lower legform were unlikely to be the reason for the change to a 60° plane, as the decision predated the availability of a working lower legform

Understanding of issue: Use of 60 degrees in other regulations

- UNECE Reg. 42, FMVSS581 (USA) and CMVSS581 (Canada) were mentioned as using 60° in an EEVC WG17 document
- All three involve testing to ensure the effectiveness of the bumpers in protecting the vehicle from damage in minor impacts
- UNECE Reg. 42:
 - Defines the vehicle corner using a plane at 60°
 - Requires two types of test:
 - a longitudinal impact test, with the extremities of the impactor to be between the vehicle corners
 - a corner impact test, with the impactor at 60°, so the impact will be centred on the corner

Understanding of issue: Use of 60 degrees in other regulations

- Comparing Reg. 42 (front and rear protective devices) and Reg. 127 (pedestrian safety performance), etc.
 - Both use a plane at 60° to define the corner
 - Reg. 127 uses the corner as the limit of the tested area, with impact centres at least a legform radius inside the corner
 - Reg. 42 uses the corner to define the centre of the impact for the corner test. The tested area will extend significantly beyond the defined corner.
- Is it appropriate to use the same 60° corner definition when the definitions are used differently?

Euro NCAP bumper corners and test points

Summary of information supplied to Task Force

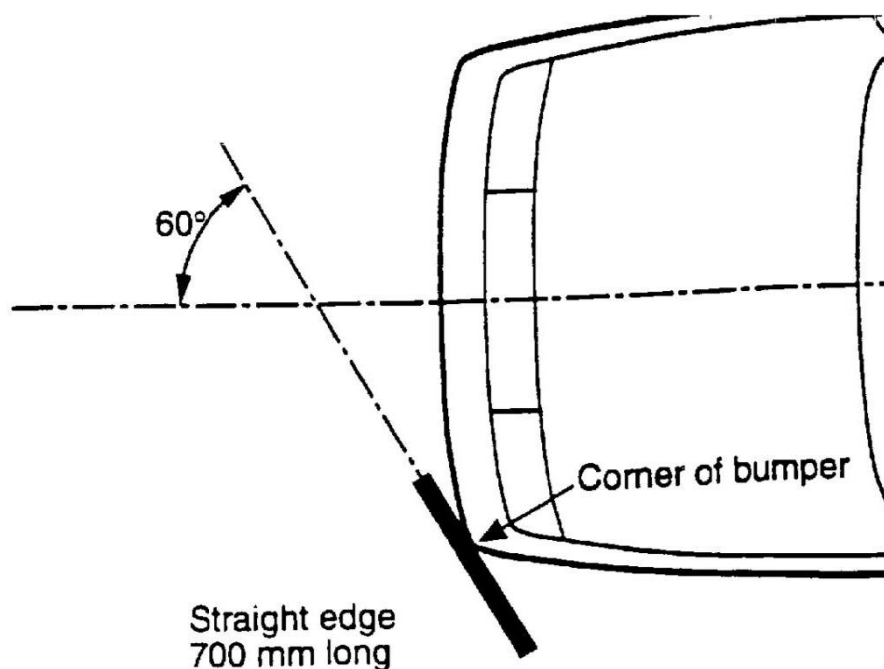

Version 2.0 Testing Protocol

- November 1999
- Bumper Corner:
 - Point of contact with a straight edge, at 60° to the vehicle's vertical longitudinal plane
- Test Points distributed between bumper corners
- Designed to test the portion of the front bumper that is likely to be struck by a pedestrian
- Bumper corner definition remains unchanged despite modern car design

Euro NCAP bumper corners

VW Golf evolutions

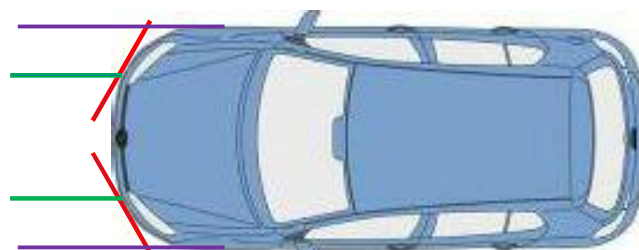

2009-2012
(Mk VI)

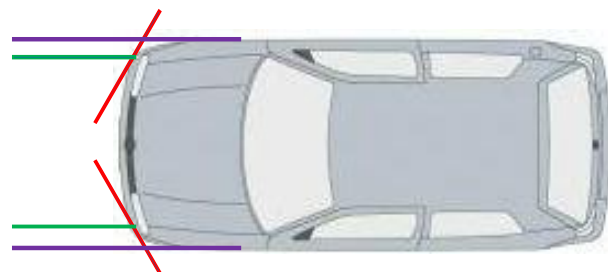

1997-2003
(Mk IV)

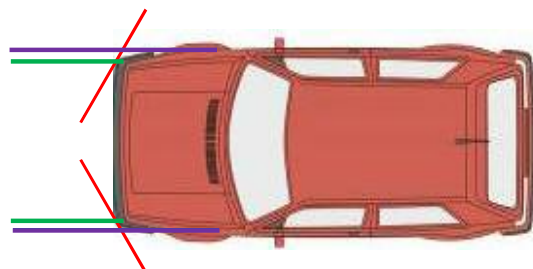

1983-1992
(Mk II)

Bumper Design Trends

- Vehicles incorporating more “curvey” front bumpers
- Technical Working Group became aware that testable zones were becoming smaller relative to the width of the vehicle
- TWG began privately monitoring vehicles and testing performance outside of the defined bumper corners

- Red lines – 60° planes
- Green lines – corners
- Purple lines – width of vehicle

Examples: Testing outside corners

Volvo V60

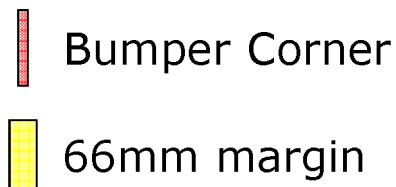

Private Monitoring and Testing

- TWG identified the Volvo V60 for monitoring
- Tested 2 points outside of conventional areas
 - “S2” – On the bumper corner (disregarding the 66mm margin)
 - “S1” – Outside the bumper corner near the tow-eye
- 3 parameters used to assess test point performance
 - Tibial acceleration (g)
 - Knee shear displacement (mm)
 - Knee bending angle ($^{\circ}$)

Examples: Testing outside corners

Volvo V60

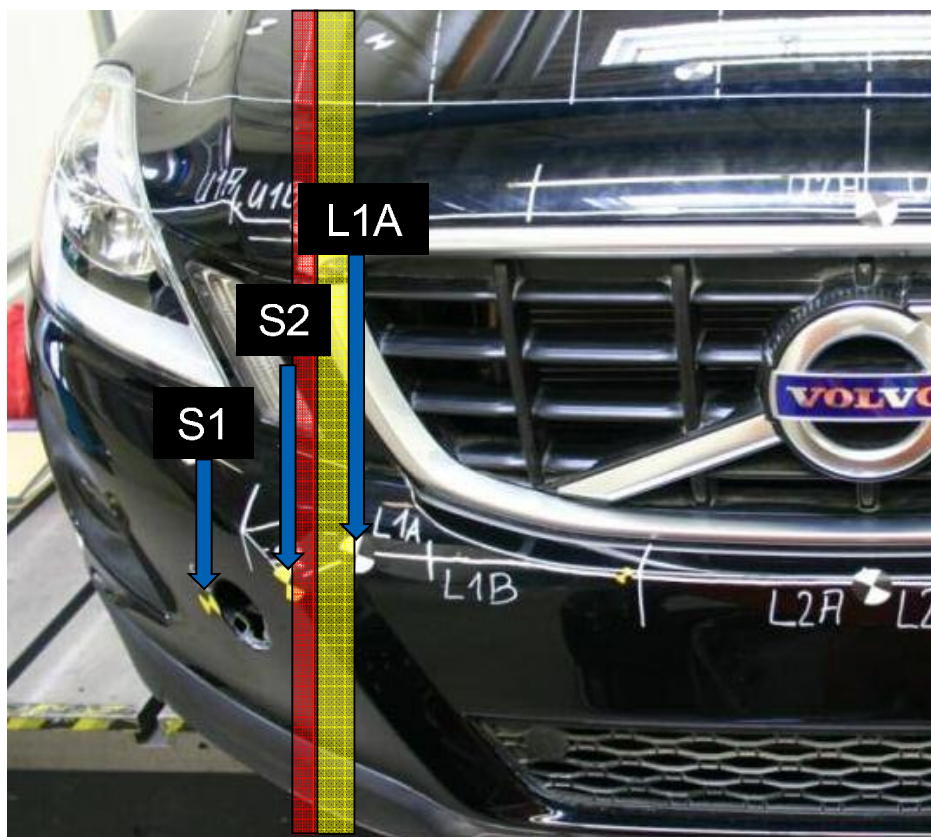

Private Monitoring and Testing

- L1A (normal test point) scored well in all 3 parameters
- S2 scored **poorly** in tibial acceleration
- S1 values for tibial acceleration and knee bending angle **failed to score in the NCAP system**

	Tibial accel (g)	Knee shear dis. (mm)	Knee bending angle (°)
L1A (normal)	91	2.0	9.8
S2	164	3.4	14.8
S1	363	3.5	25.5

Examples: Testing outside corners

Honda Insight

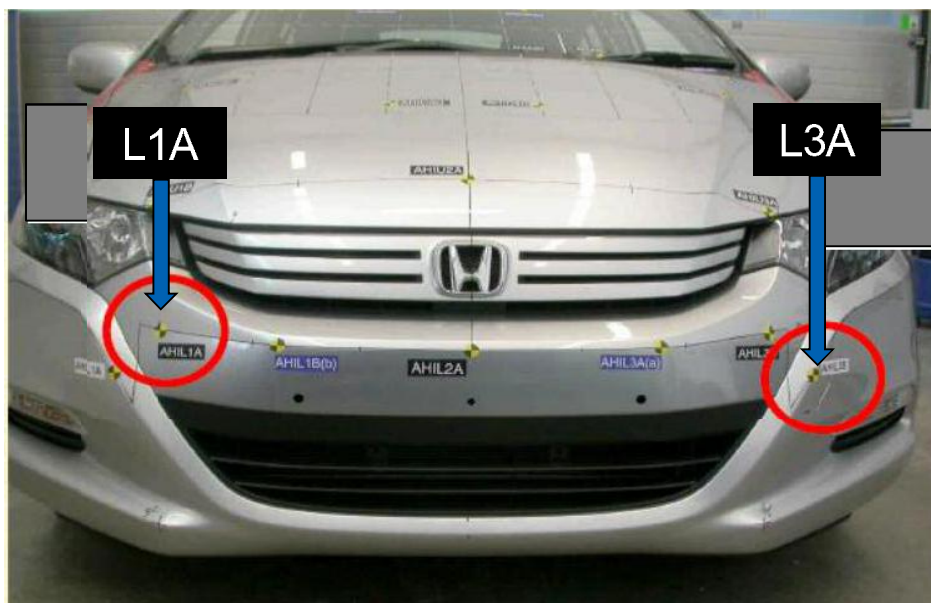

Private Monitoring and Testing

- Honda Insight also selected for monitoring and showed dramatic performance differences across the bumper
- Testing outside of the normal zone results in **failure to score under the NCAP system** in all 3 parameters

	Tibial accel (g)	Knee shear dis. (mm)	Knee bending angle (°)
L1A (normal)	91	2.0	9.8
L3A (outside)	329	7.5	22.1

Examples: Testing outside corners

Honda Insight



- Further examination of the Insight's underlying structures revealed the potential cause of the differing performance figures.



- Stiff structures beneath the front bumper panel and outboard of the bumper bar and pedestrian protection structures were associated with the poor performance.

Monitoring

Bumper Removal



Private Monitoring and Testing

- Euro NCAP began removing the bumper panels to reveal the underlying structures
- Applied 60° plane to underlying structures (i.e. bumper bar)
- Had the general effect of increasing the bumper width
- Structures outside of the bumper bar that were still identified as potentially injurious
- But there are experimental difficulties in testing these outboard structures

Monitoring

Experimental difficulties





	Normal test zones			Monitored test zones	
	L1A	L2A	L3B	L3bis	L3out
Knee bending angle - deg	9.43	3.55	9.43	0.3	0.11
Knee Shear Displacement - mm	2.24	2.69	2.24	1.49	1.57
Tibial acceleration - g	109.6	108.1	109.6	50.2	70

Oblique surfaces

- Monitoring highlighted experimental difficulties when testing structures outside of bumper corners
- Surfaces tend to be at oblique angles
- Inconsistencies were recorded in all parameters
- The decision was made to limit testing to within the edges of the bumper bar to prevent experimental discrepancies

Summary: Changes to Euro NCAP Testing Protocol

Amendments made during monitoring period

v4.2 (June, 2008)	v4.3 (Feb, 2009)	v5.0 (Oct, 2009)
<ul style="list-style-type: none">▪ v4.2 used during monitoring period▪ Bumper corners defined by 60° planes▪ 3 impact points along the bumper (>132mm apart)▪ Points must be a minimum of 66mm inside the corners▪ Additional tests may be performed on injurious structures outside of the corners 	<ul style="list-style-type: none">▪ Initial amendements:▪ Bumper corners defined by 60° planes▪ 3 impact points along the bumper (>132mm apart)▪ No 66mm margin – can test up to corners▪ Additional tests may be performed on injurious structures outside of the corners – results included in final report of vehicle 	<ul style="list-style-type: none">▪ Major amendements:▪ Bumper corners defined by 60° planes▪ Bumper panel is removed before testing▪ 3 impact points along, BUT limited to the bumper bar (>132mm apart)

Vehicle geometry

- Consider the proportion of vehicle front outside of test area
 - What is representative of the vehicle fleet?
 - Vehicle measuring task
 - Compare width of vehicle with bumper test area
 - Is any further information available to support this task?
 - Request for vehicle geometry information included as action in minutes from 1st meeting
 - Presentations made available from Audi and BMW
 - Thank you

Vehicle geometry

- Car selection based on the most popular manufacturers and models:
 - 2012 Sales figures for top 10 vehicles in Europe
 - JATO, Dec 2012
 - 2012 Sales figures for top 10 vehicles in UK
 - DfT statistical data set VEH01, Nov 2012
- Mostly the same manufacturers and models
- Best selling vehicles likely to be in greater number of accidents due to sheer numbers
 - No statistics to support this yet



Vehicle geometry

2012 sales figures for best selling cars

Top UK Sellers	
1. Ford Fiesta	96,112
2. Ford Focus	81,832
3. Vauxhall Corsa	77,751
4. VW Golf	63,368
5. Vauxhall Astra	62,575
6. Vauxhall Insignia	46,324
7. VW Polo	45,992
8. BMW 3'series	42,471
9. Nissan Qashqai	39,406
10. Mini Mini	35,845

Top European Sellers	
1. VW Golf	408,412
2. Ford Fiesta	389,553
3. VW Polo	269,000
4. Vauxhall Corsa	249,596
5. Ford Focus	226,378
6. Renault Clio	225,287
7. Vauxhall Astra	216,802
8. Nissan Qashqai	193,695
9. Renault Megane	184,633
10. VW Passat	182,194

Vehicle geometry

Measurements of testable area

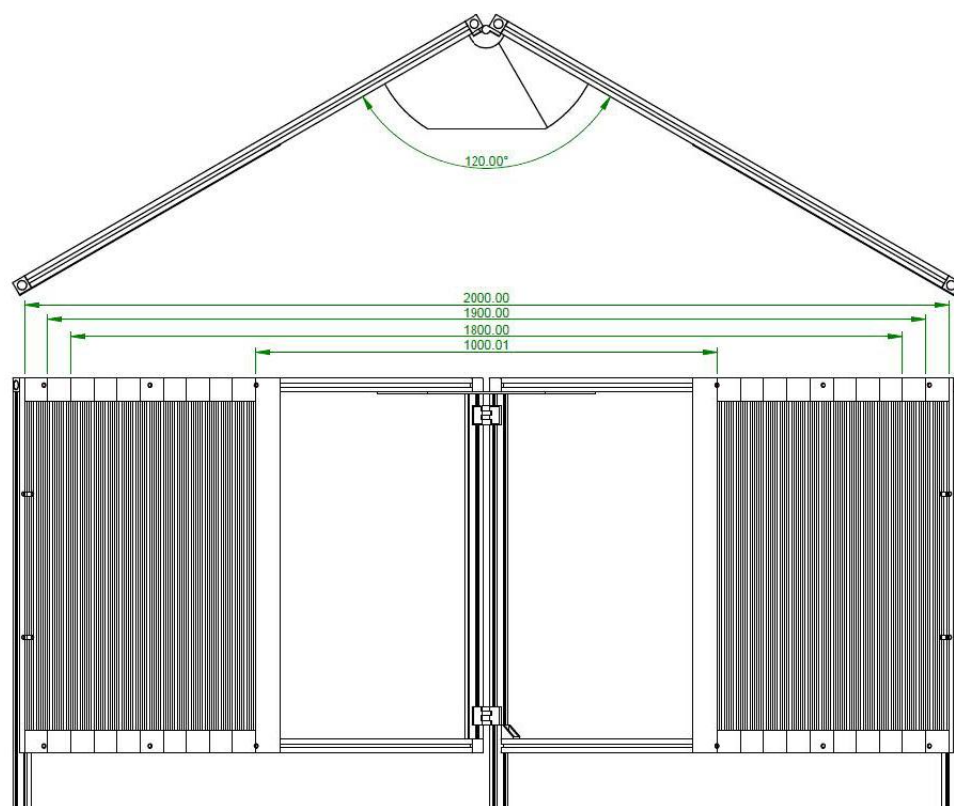

Bumper corner measuring device

- Collapsible device machined out of aluminium and steel
- Opens and locks at 120° angle
- Measures distance between panels when locked in position
 - 10mm gradations lasered onto panels
- Designed to immitate regulatory procedure for defining bumper corners and measure the testable area between bumper corners
- Also locks into 90° angle

Vehicle geometry

Measurements of testable area



- Measuring device is locked into 120° angle
- Aligned with centre of vehicle front
- Walked forwards until contact made

- Points of contact define the “bumper corners”
- As per regulatory testing
- Gradations accurately measure distance between corners

- Distance between corners compared against the quoted total width of the vehicle (excluding door mirrors)
- Procedure is then repeated at 90° angle

Example results of vehicle measurements

Bumper "corners" displayed with blue lines:



Example results of vehicle measurements

1. Ford Fiesta – 389,553

2002-2008

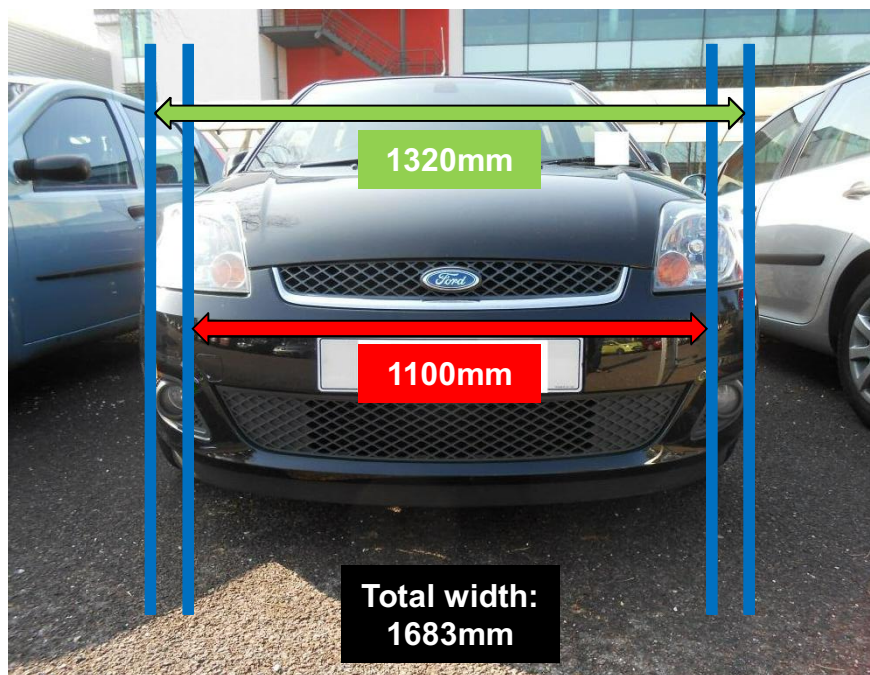

% of vehicle width tested

90°	79%
120°	65%

2008-2012

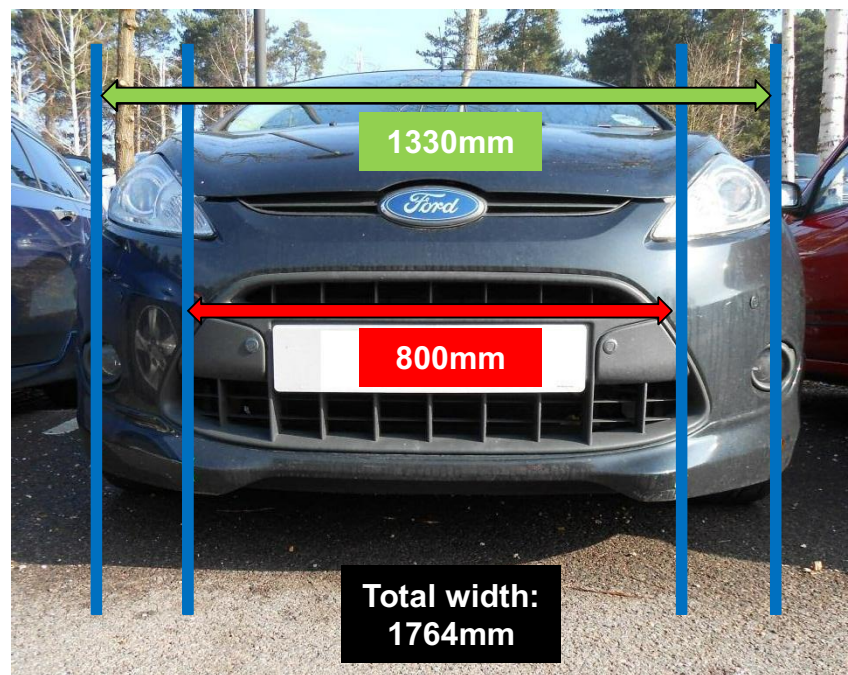

% of vehicle width tested

90°	75%
120°	46%

Example results of vehicle measurements

2. Ford Focus – 226,378

2007-2010

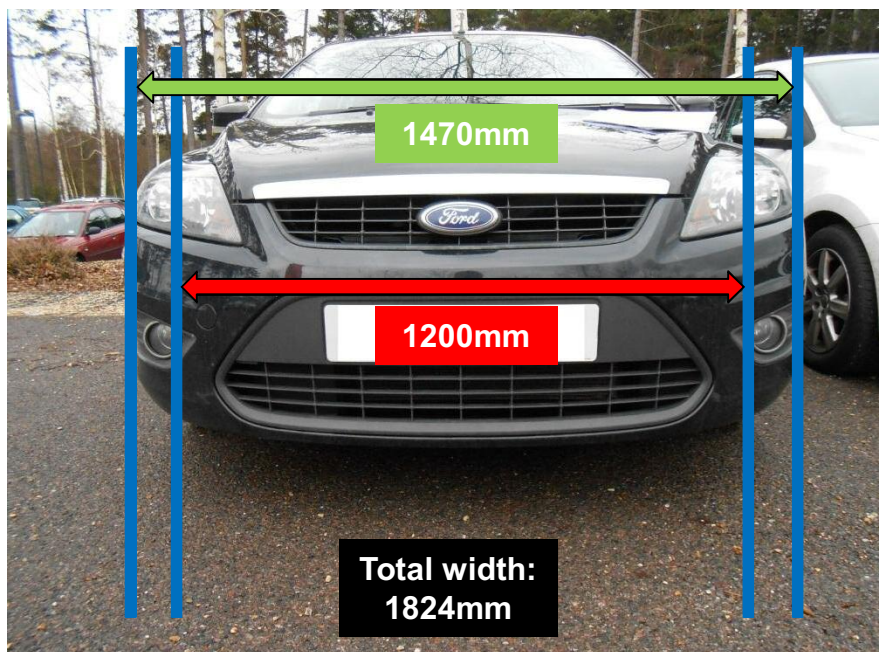

% of vehicle width tested	
90°	81%
120°	66%

2010-Present

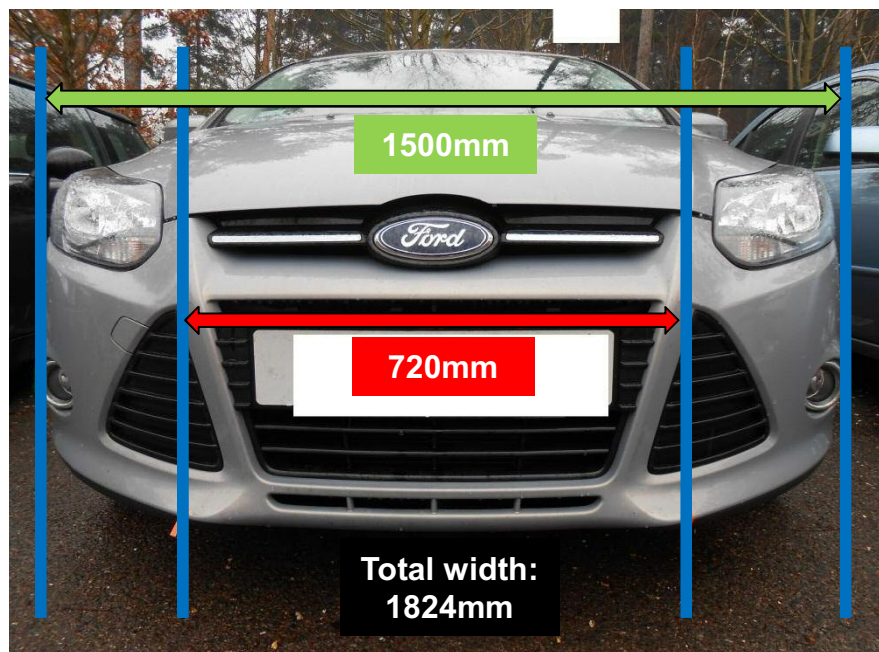

% of vehicle width tested	
90°	82%
120°	40%

Example results of vehicle measurements

3. Vauxhall Corsa – 249,596

2000-2006

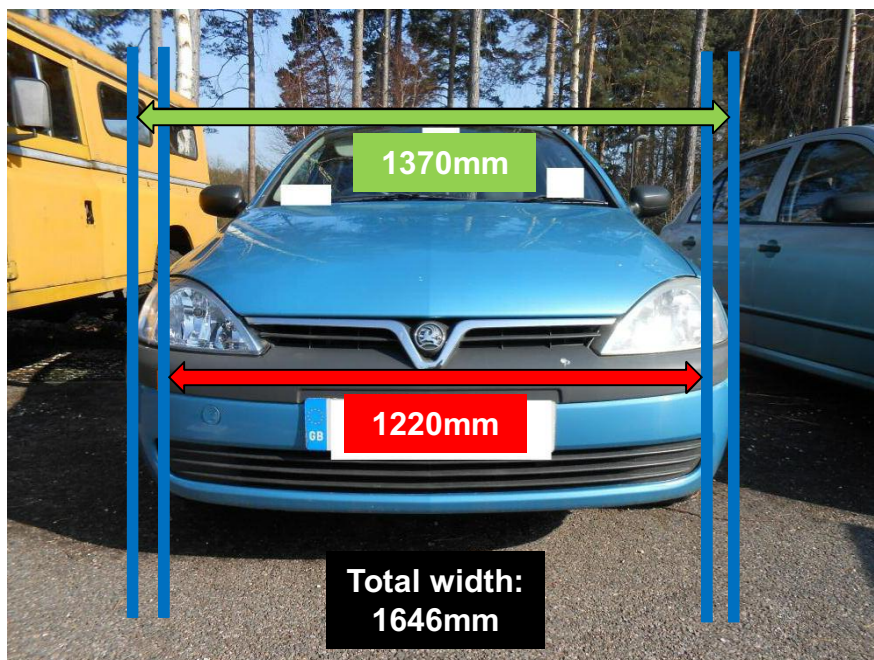

% of vehicle width tested

90°	83%
120°	74%

2006-Present

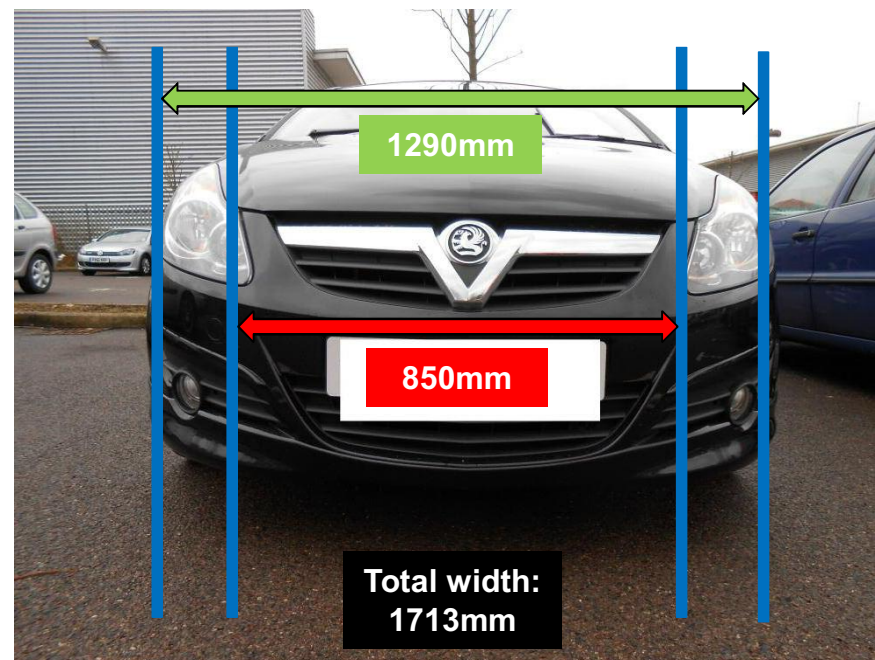

% of vehicle width tested

90°	75%
120°	50%

Example results of vehicle measurements

5. Vauxhall Astra – 216,802

2004-2009

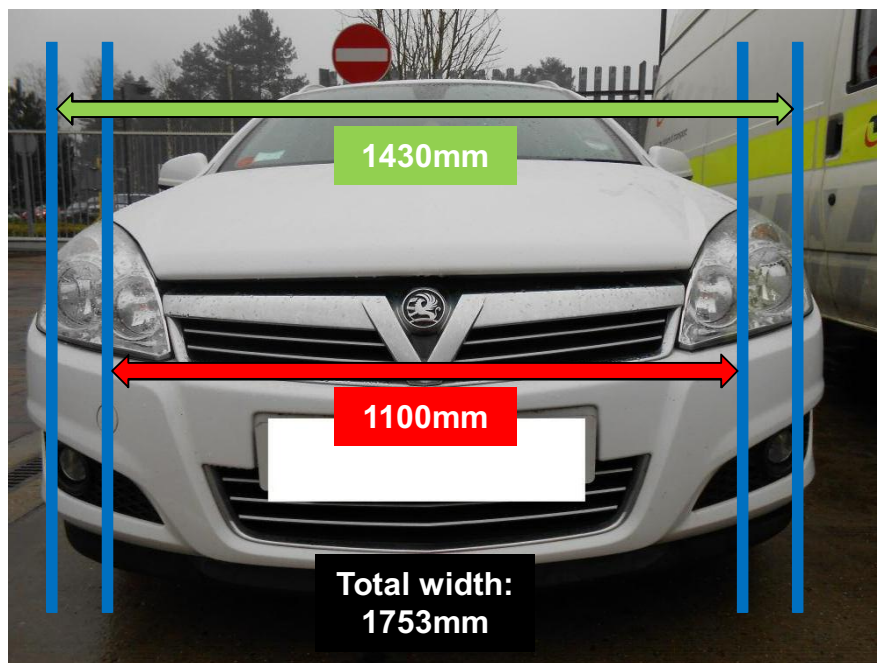

% of vehicle width tested	
90°	82%
120°	63%

2009-Present

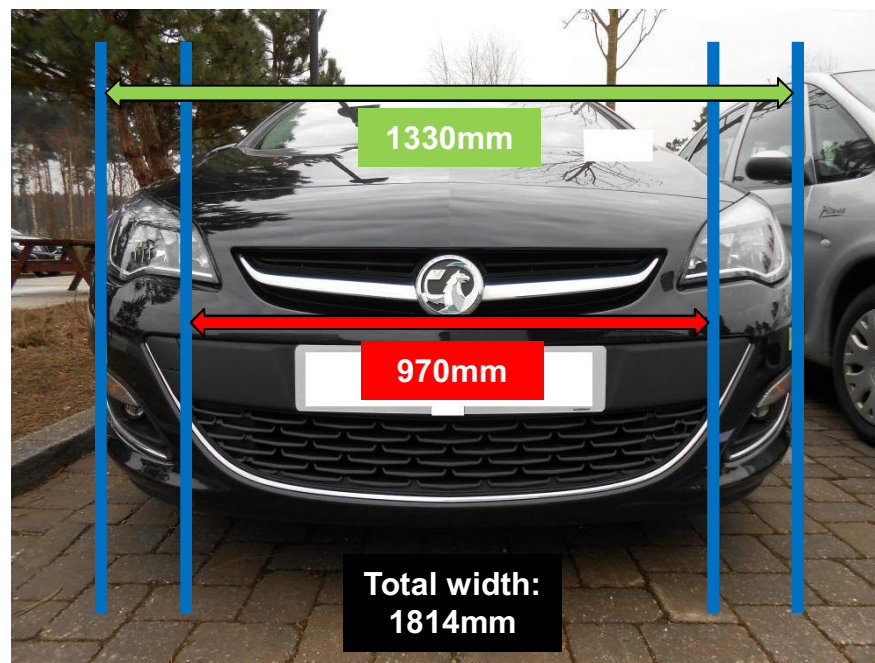

% of vehicle width tested	
90°	73%
120°	54%

Trend in testable area compared with vehicle width

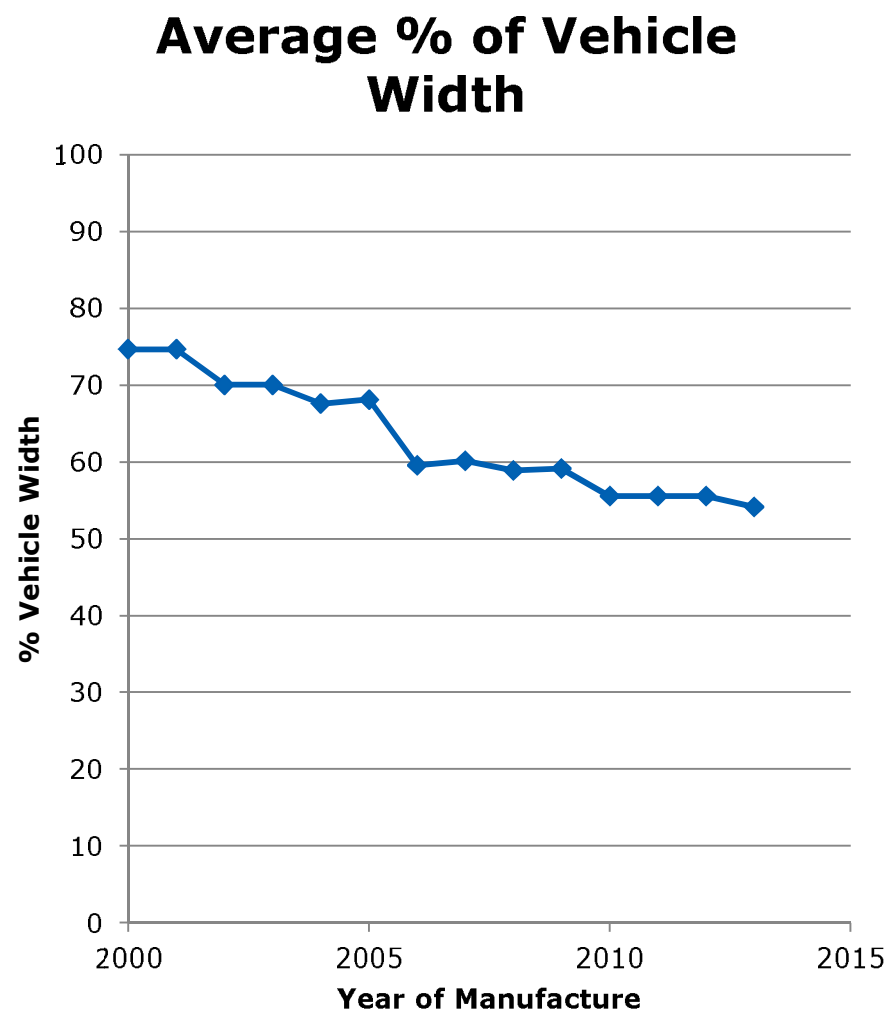

Testable area of bumper

- Testable area decreasing with newer vehicles
- Preliminary graph based on only 11 cars in recent evolutions
- From manufacturers:
 - Ford
 - Vauxhall
 - VW
 - Renault
 - BMW/Mini
 - Nissan

Legform test work

- Evaluate typical vehicles with legform impactors
 - Want to know level of protection offered inside and just outside of current regulatory test area

 - Ideally, this task should use both EEVC impactor and FlexPLI
 - Maximise usefulness of study
 - Could provide comparative test data (if that is useful for GTR Phase 2)
 - Suggestion from Dr. Konosu to start initial phase with EEVC impactor
 - Move to prove-out phase with FlexPLI later

 - Test programme could be extended substantially depending on costs for cars and car parts
 - Suggestions for
 - Priorities for testing
 - How to get most from available resource

Legform test work

Test programme

Typical cars	Legforms	Test ideas
<ul style="list-style-type: none"> ▪ Based on vehicle geometry task ▪ Representative modern vehicles ▪ Ideally two or more models ▪ Perhaps one narrow test area car and one wide area car ▪ Consider previous version of model if style change is obvious 	<ul style="list-style-type: none"> ▪ As mentioned, start with EEVC legform <ul style="list-style-type: none"> ▪ Test initial ideas ▪ Investigate practical limits ▪ Refine ideas ▪ FlexPLI dependent on GTR Phase 2 scheduling ▪ Also consider need to use upper legform for high bumper tests 	<ul style="list-style-type: none"> ▪ 5 or 6 tests per car? ▪ Around bumper corner ▪ Need to consider options for changed definition – must receive those options in good time ▪ Info from Euro- and J-NCAP could be used here to help define tests

Legform test work

Test programme

- Considering...
 - Ford Focus
 - Popular small family car
 - Styling clearly gives small bumper area
 - Noticeable change from previous version

 - VW Polo (or)
 - Opel/Vauxhall Corsa
 - Popular superminis
 - Polo shows characteristic VW angular spoiler profile
 - Corsa shows progressive curved profile

 - Comments or other suggestions are welcomed

Benefit of change

- Effectiveness and potential benefit of changing bumper corner definition
 - Final task is review of potential changes with respect to the accident data
 - How many leg injuries could be saved by increasing the width of the bumper test area?
 - Previous assumption that distribution of contact points is even across vehicle front (bias to one corner is offset by reduction to other side, etc.)
 - How did example vehicles perform around the corner region?
 - It could be that a change in the test area would not alter the accident situation very much
 - Some discussion of this at the 1st meeting
 - Need to confirm one way or the other

Benefit of change

- Project will provide European data analysis
 - Considering OTS and GIDAS data
 - Also potentially can include information from the APROSYS database

- Delighted to receive other information regarding injurious contacts (or otherwise) outside of the bumper corners

Summary

- Provided a brief update of initial progress with the EC study
 - Task to document:
 - Understanding of current definition
 - Previous research
 - Vehicle geometry
 - Testing
 - Benefit estimate

- Opportunity to comment
 - Project intended to complement activity within Task Force
 - Contribution to Task Force will be greatest with input from all stakeholders
 - Suggestions are still welcomed

Summary

Opportunities for cooperation – as discussed



- Exchange of discussion documents, data and test results
- Vehicle geometry information

- Proposed test vehicles
- Proposed alternative definitions
- Suggestions please



- Will review accident data for Europe
- Happy to receive information from Japan
- Need to consider how results and analysis will affect other regions



Do You Have Any Questions?

Thank you Task Force – Bumper Test Area: EC study update

Presented by Jolyon Carroll
Senior Researcher – 18 March 2013
Tel: +44 1344 770564
Email: jcarroll@trl.co.uk