

Willkommen  
Welcome  
Bienvenue



# Preliminary investigations of morphology and composition of brake wear particles

P. Dimopoulos Eggenschwiler, A. Liati, D. Schreiber

47<sup>th</sup> PMP Meeting 16 - 17 May 2018

Joint Research Centre, Ispra  
Via Enrico Fermi 2749, Ispra (VA) 21027, Italy

# Exhaust and non-exhaust sources contribute equally to total traffic related PM10 emissions

## Non-exhaust road traffic particles

- Abrasion generated tire, brake, clutch, road surface, engine, wheel bearings, corrosion, street furniture and crash barriers wear
- Resuspension of material deposited on road surface and environment

## Brake wear particles

- 11-21% of total traffic related PM10
- 16-55% of non-exhaust traffic related PM10

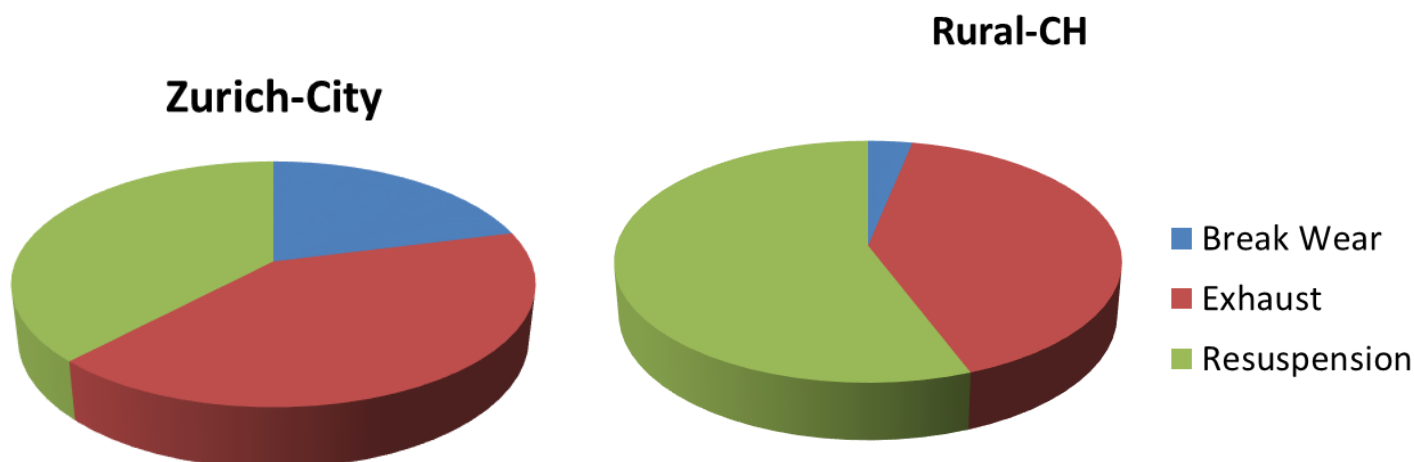

# Brake pads comprise of binders, fibers, fillers, frictional additives/lubricants and abrasives

## Parameters

- materials (pads, disc) in general non disclosed
  - Pads: NAO (non-asbestos organic), metallic, semi-metallic and low metallic
  - Disc: Cast Fe, Cast Fe with coating, Carbon
- driving behavior, frequency and severity of braking, sliding speed, nominal contact pressure,
- temperatures

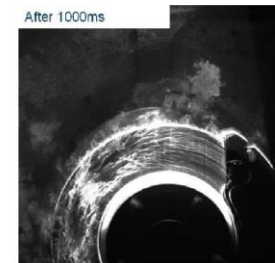
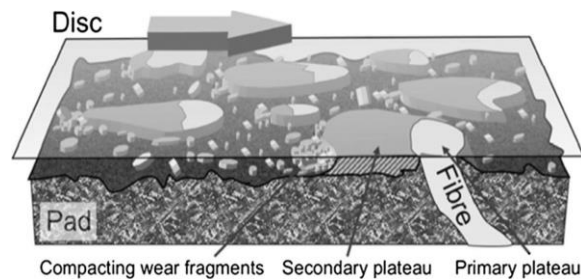
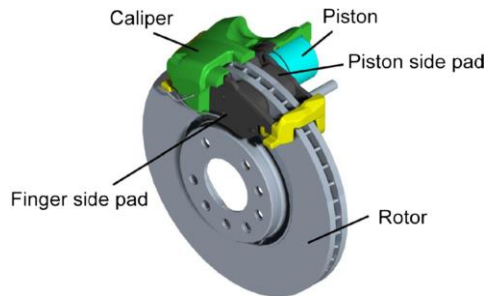

# Lack of standardized sampling procedure; difficult comparison of results and conclusions

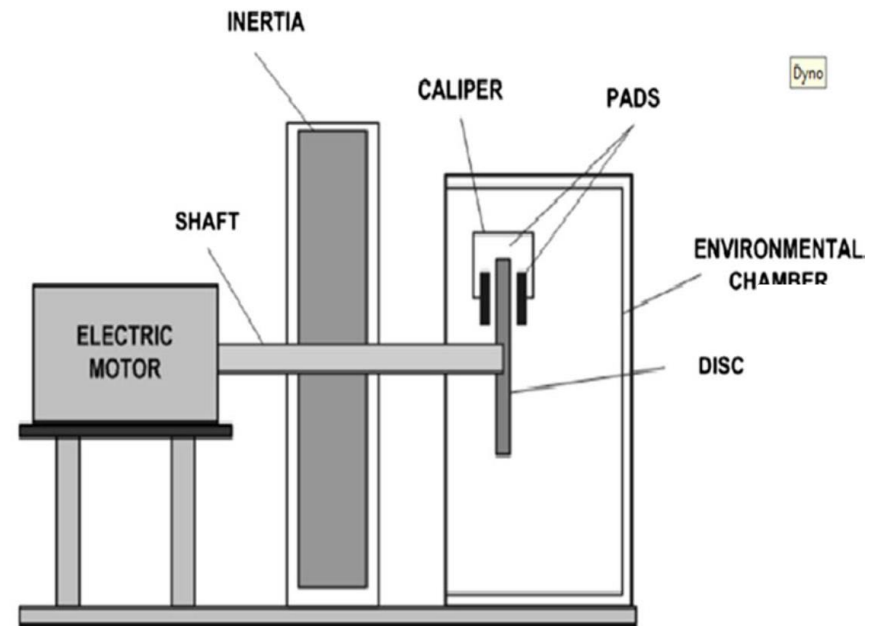
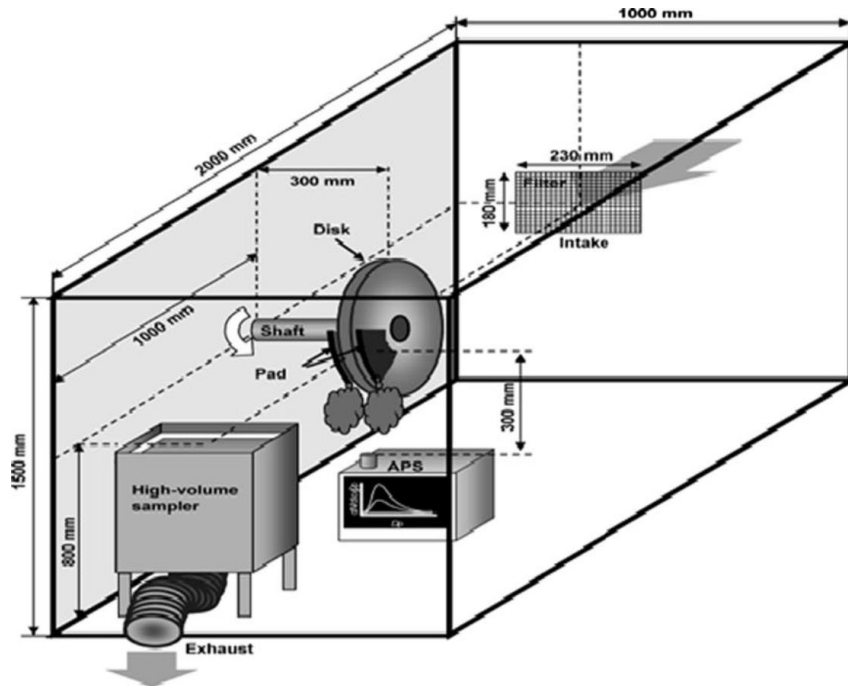

# Particle size and chemical compositions are the key factors for toxicity

- Mechanical abrasion particles are expected to be coarse and “edgy”
- Fine and ultrafine particles are rather formed by the evaporation/condensation process with subsequent aggregation
- Reported size distributions and chemical composition vary

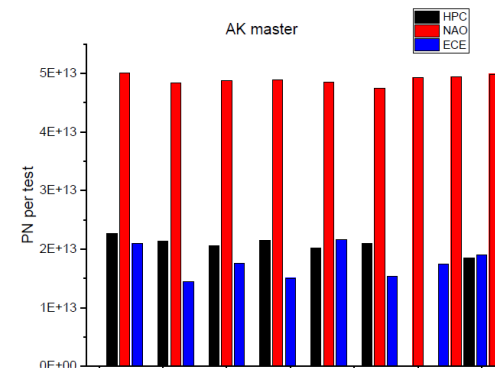
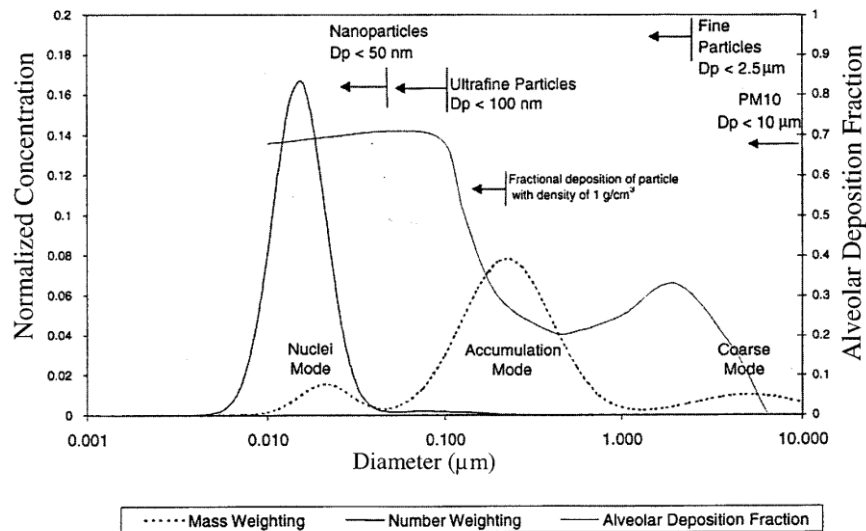

# The present work was financed by the Swiss Federal Office of Environment

- Joint project



- Test bench and braking cycles defined
- Samples were collected on polycarbonate foils with a 13-step impactor (last stage of the impactor collected particles <30nm)
- Particle size classes were defined by the impactor relative to the equivalent aerodynamic diameter. Compared to the equivalent electric mobility diameter, the diameters are smaller in this case.
- Size classes examined by Electron Microscopy
- Two different sets of brake pads and discs

# Cascade low pressure impactor has been used for separating the particle in size classes

- Impactor functional principle is based on the deflection of a free jet through an angle of  $90^\circ$
- The gas and the particles are accelerated by a nozzle, smaller particles can follow the flow and deflect, larger particles are not deflected and hit the impactor plate
- An adhesive covering (foil), ensures that deposited particles remain on the impactor plate
- Characteristic for the impactor are the cut-off diameters  $d_{50}$ , indicating at which aerodynamic diameter the deposition efficiency is 50%

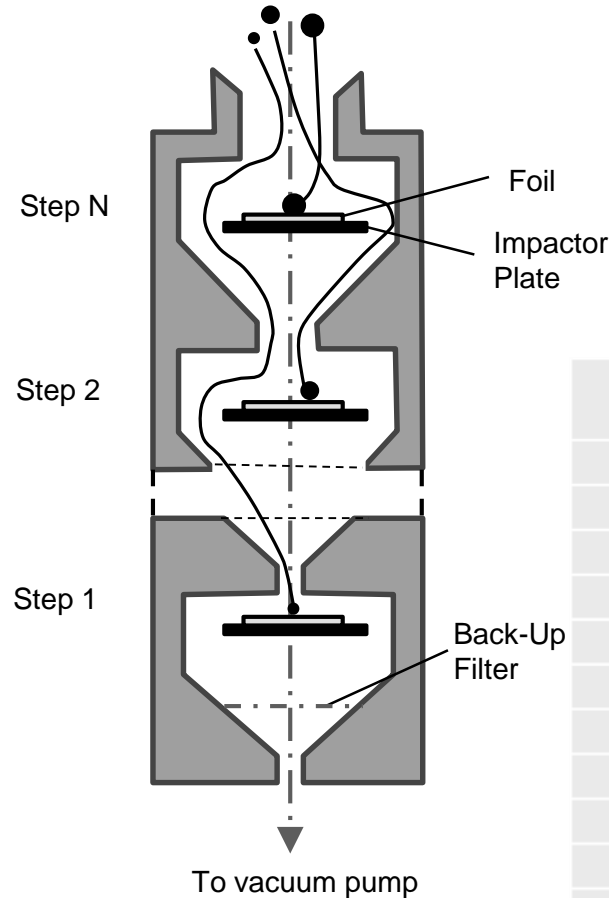

Step	D 50% [ $\mu\text{m}$ ]	Di [ $\mu\text{m}$ ]
1	0.032	0.0456
2	0.065	0.0853
3	0.112	0.1411
4	0.178	0.2200
5	0.272	0.3359
6	0.415	0.5276
7	0.671	0.8365
8	1.043	1.3268
9	1.688	2.0856
10	2.577	3.2781
11	4.17	5.406
12	7.01	8.636
13	10.64	

# Defined sample preparation for the electron microscopy

- Particles of the size ranges were collected in 13 foil bags
- Foil bags cut in the middle, brought into alcohol solution and treated in ultrasonic bath for 15 minutes in order to break mechanically any weakly held aggregates. 20-30 drops of the suspension transferred on TEM grids
- Two types of TEM grids: (a) Cu-supported holey carbon-grids (in this grid-type the carbon film contains numerous holes where particles are supposed to be caught) and (b) Cu supported thin carbon films (the carbon film contains no holes). Type (b) was more useful for the small size fractions since there were no particle losses through the holes
- Due to the grid material, Cu- and C-peaks appear always on the EDX spectra; thus Cu and C are difficult to be detected in the samples unless they are present in very high amounts. For the samples investigated by SEM, the sample holder contains also Au; thus Au peaks on the EDX spectra are ascribed to the sample holder material.



# Methods: Scanning (SEM) and Transmission Electron Microscopy (TEM) with EDX

- **SEM:** Particle imaging and chemical composition combination with an Energy Dispersive X-Ray system (EDX) for chemical composition (qualitative results)
  - Secondary electron (SE) images: topography of particles (surface features)
  - Back scattered electron (BSE) images: chemical differences by variations in brightness (brightness correlates positively with the atomic number of the participating element and/or with the particle's thickness)
  - Element mapping for selected aggregates of larger sizes
  
- **TEM** (smallest particle fractions: step 1 and 2)
  - Particle imaging and chemical composition (EDX)
  - TEM mode (low and high magnification/resolution)

# Abundant very thin and round particles below 50nm

- Abundant particles <50nm on SEM and TEM images (both sets)
- Larger particles (>50nm to a few hundreds of nm) also occur
- Particle shapes are mostly round; particles are very thin
- TEM EDX showed Ca, Fe (SET 1) and mostly Fe (SET 2)

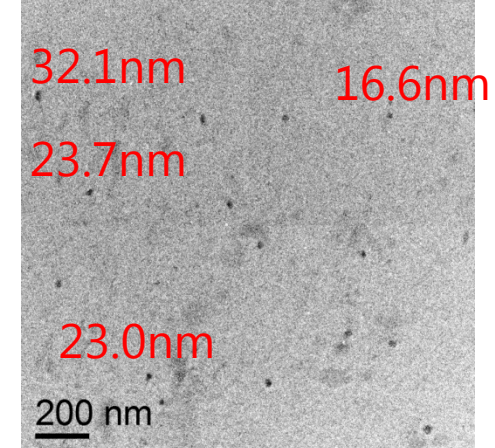
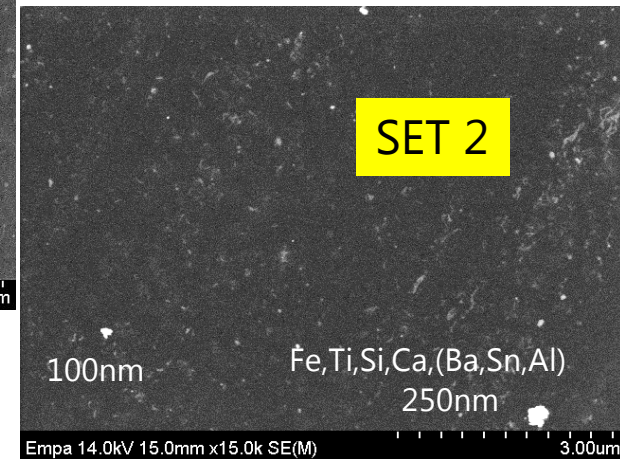
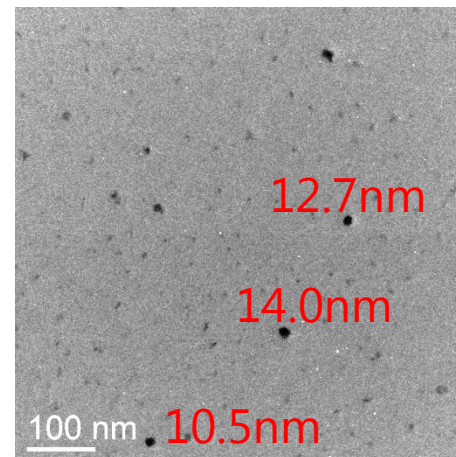
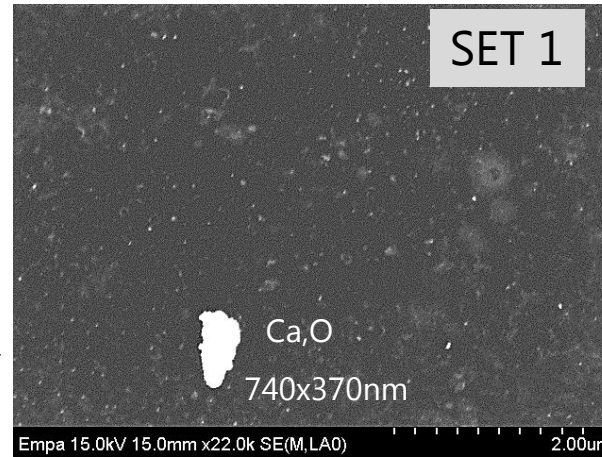

Agglomerates composed of nm-large particles with homogeneous or heterogeneous composition are common

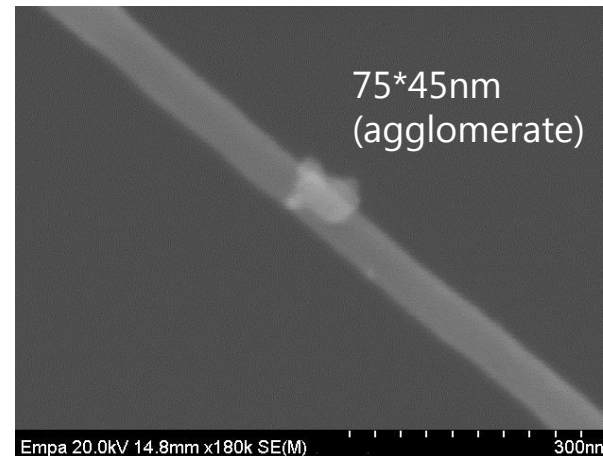
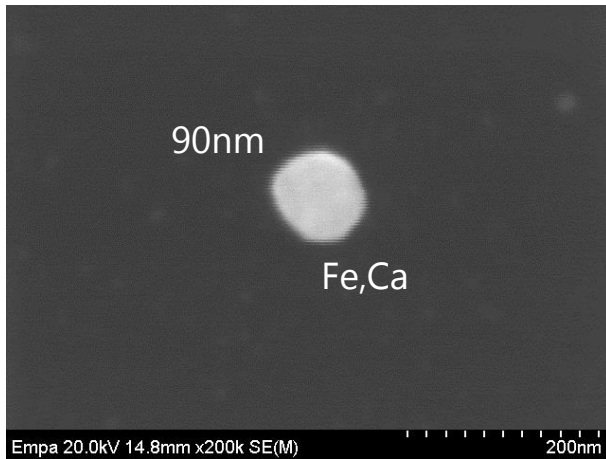

SET 1

STEP 1 (45nm)

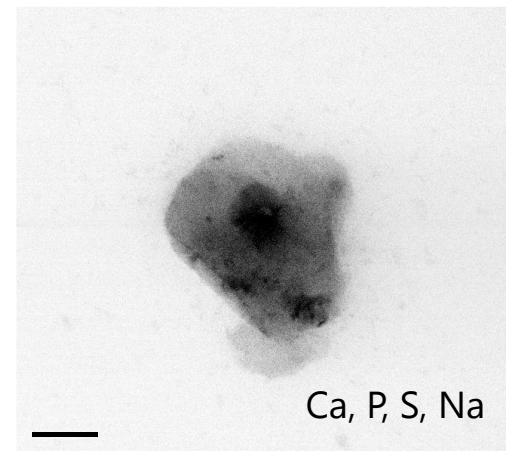
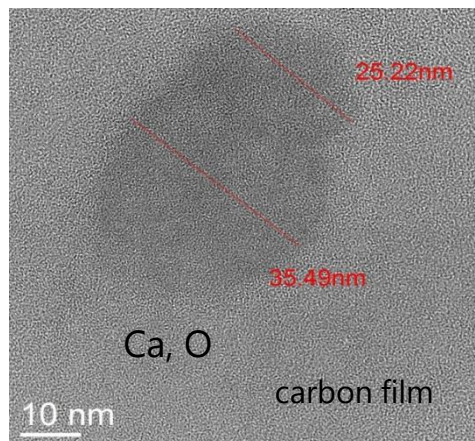

SEM (upper row) and TEM (lower row) images of the smallest size particles

# Abundant particles <100nm

- Shapes are spherical and irregular; outlines are rounded
- Most particles Ca-bearing; some also Al, Mg, and less K±Ti

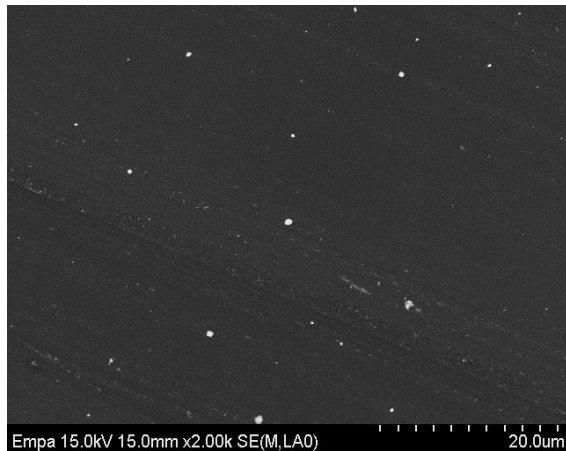

SET 1

STEP 2 (85nm)

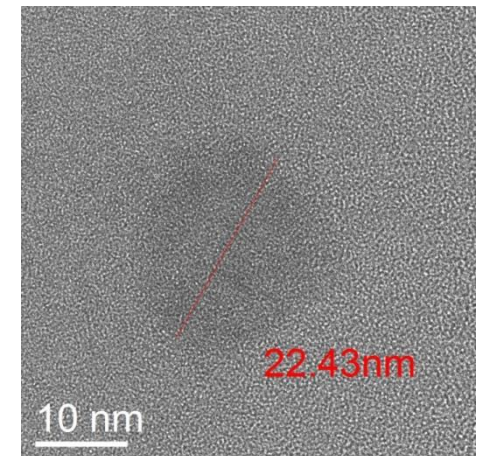
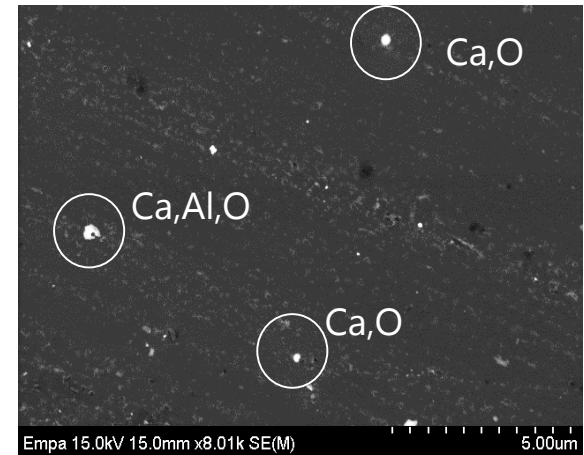
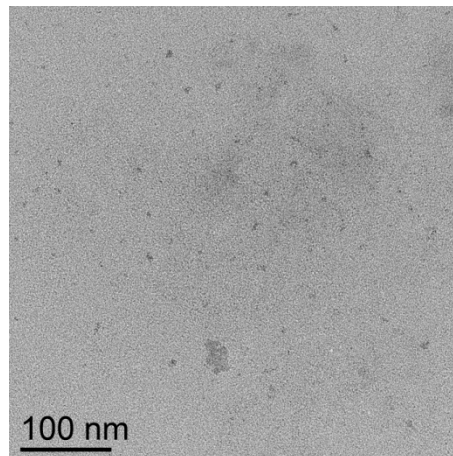

# Aggregates of particles <100nm have been observed

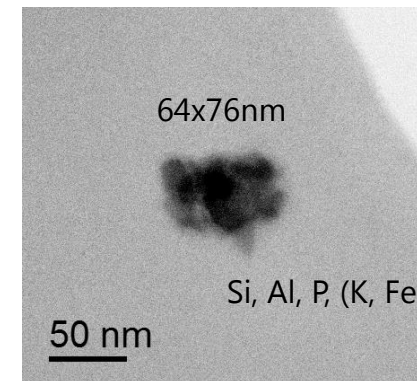
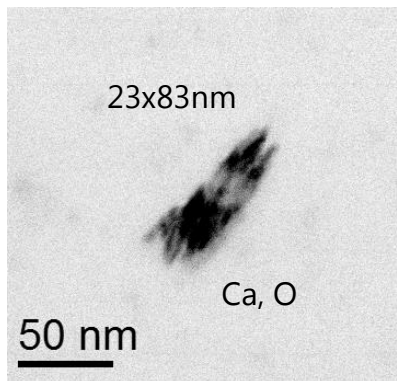
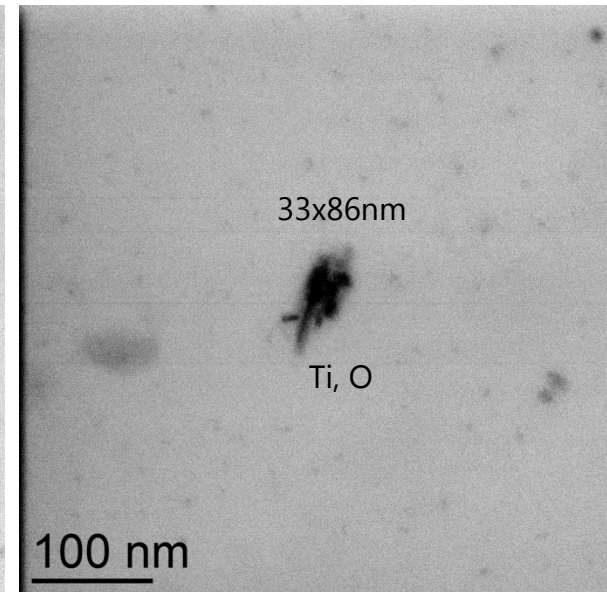
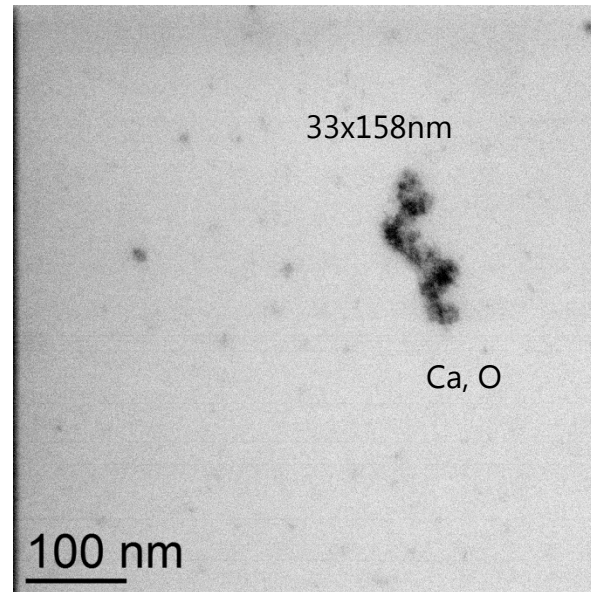

SET 1

STEP 2 (85nm)

# Aggregates of particles with homogeneous or heterogeneous composition, Ca, Fe, Al, Sn, Cr, Mg

## SET 1

STEP 3 141nm

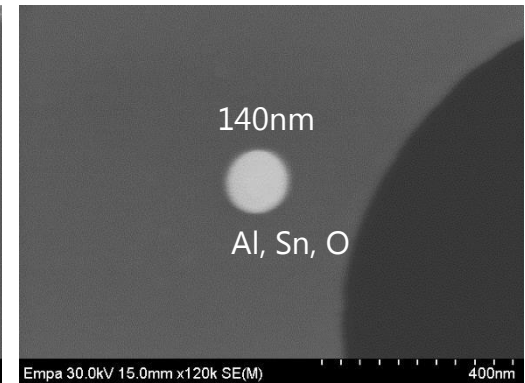
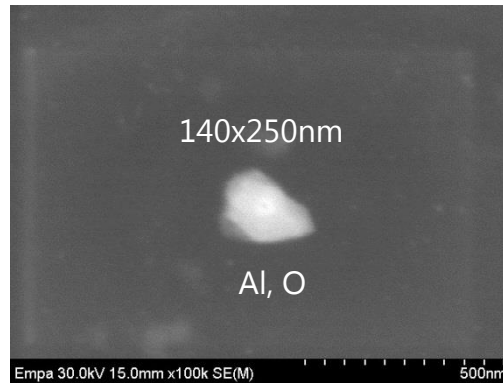

STEP 4 220nm

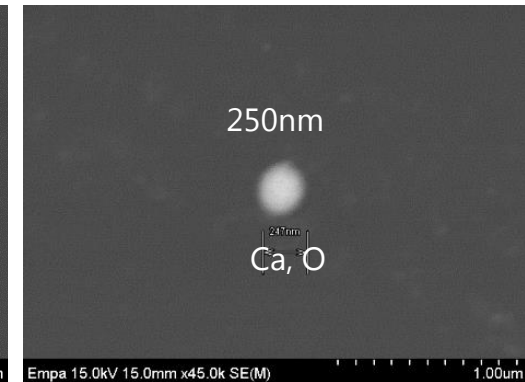
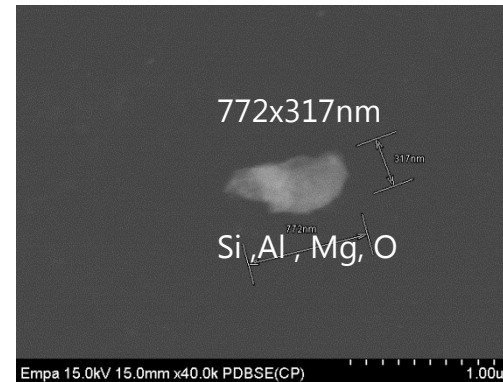
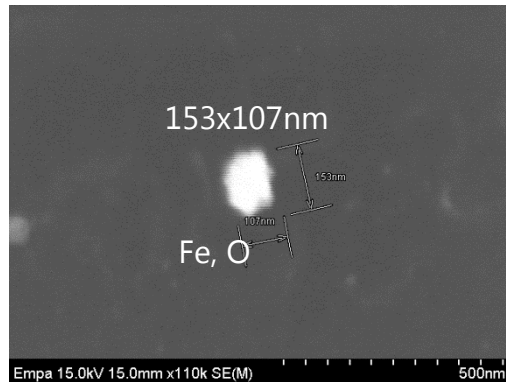

Heterogeneous composition, irregular shapes, seldom circular, Fe, Al, Sn, Mg, Cr, W and smaller amounts of Ti, Ni and Ca

SET 1

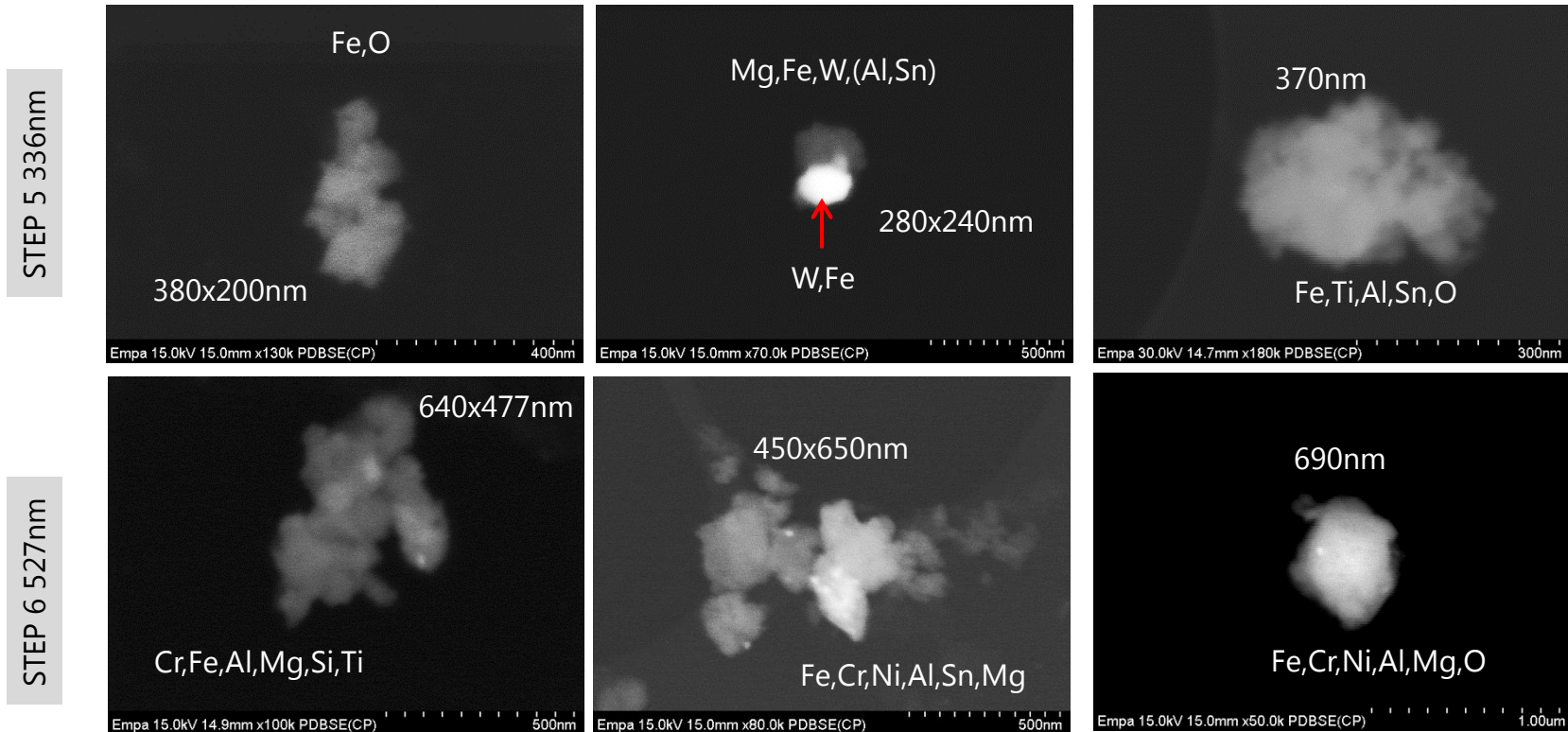

SEM BSE images of aggregates mostly revealing heterogeneous chemical composition via different brightness

# Composite aggregates and their chemical composition (Al, Mg, Si, Cr, Fe, Ca, Ba and Ti)

SET 1

STEP 6 527nm

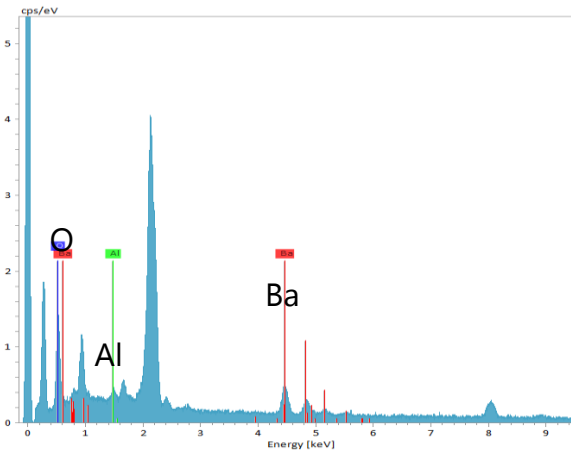
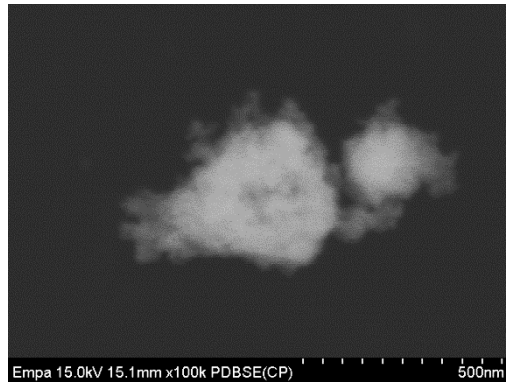
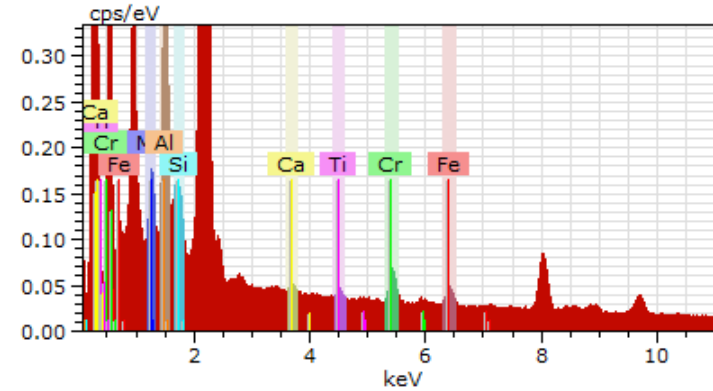
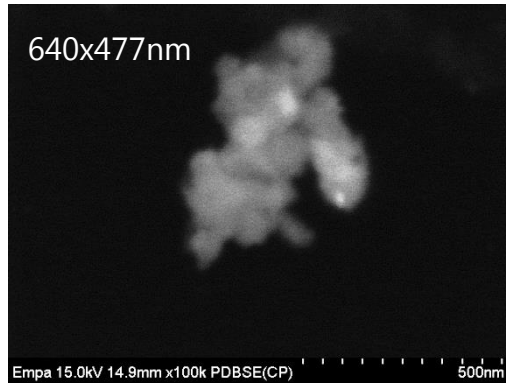



Aggregates are irregularly shaped mostly with rounded outlines Fe, Al, Mg, Si, Sn, W, Ti, Cr, K, Ca; less frequent Zn, Ba, Ca

SET 1

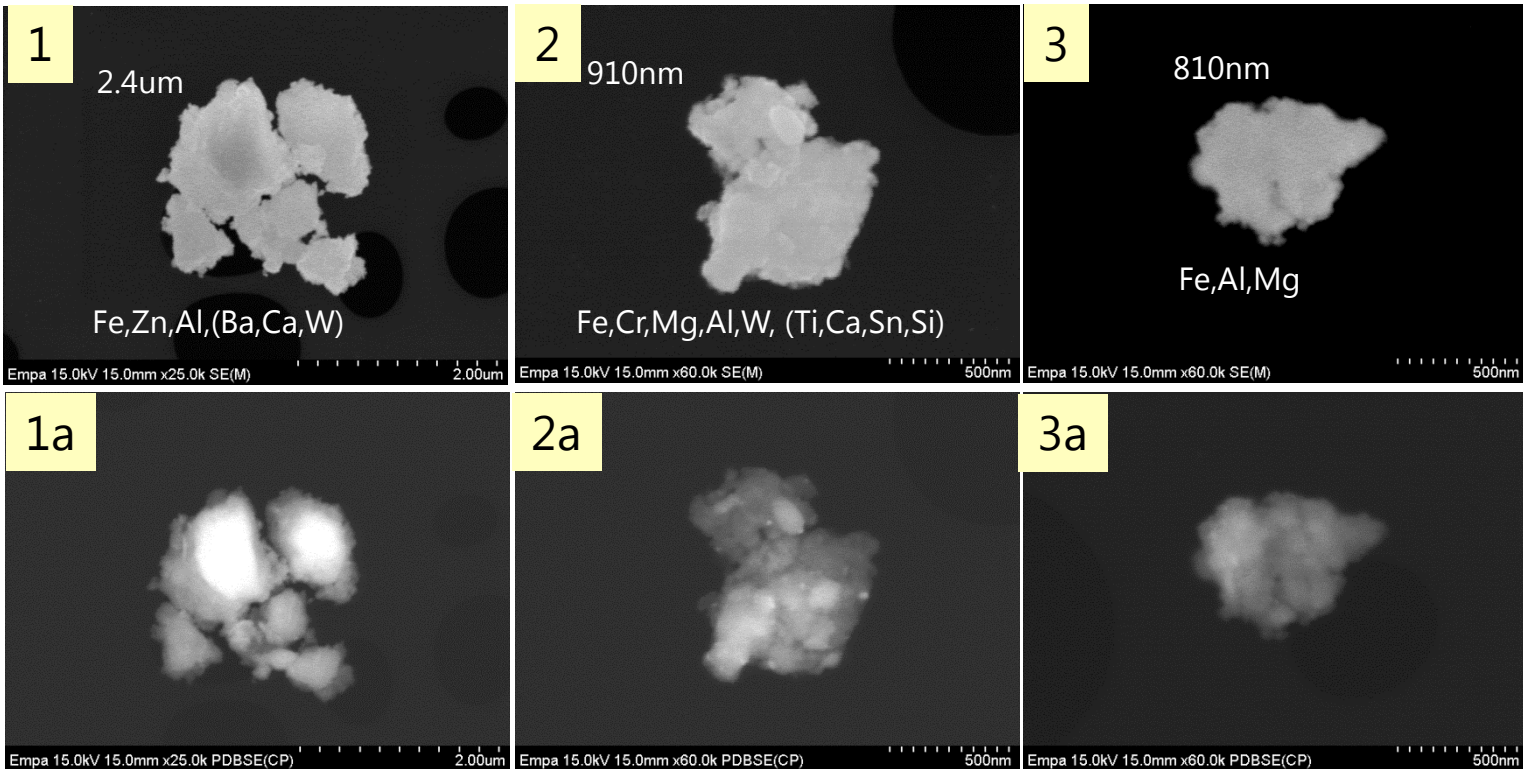

STEP 7 836nm

# Inhomogeneous distribution of the elements in the aggregates

SET 1

STEP 7 836nm

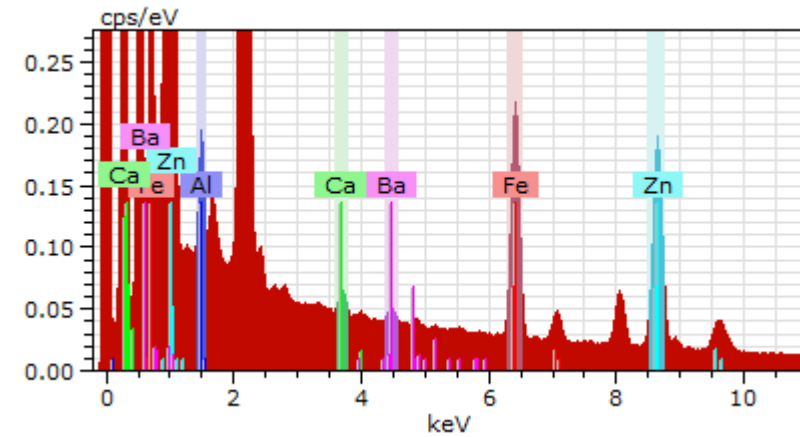
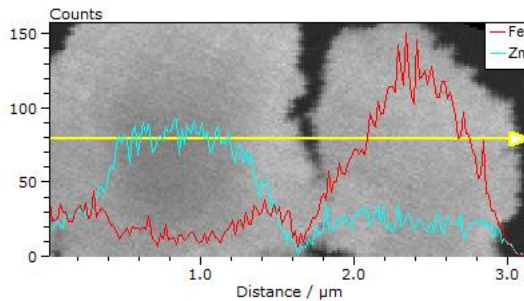
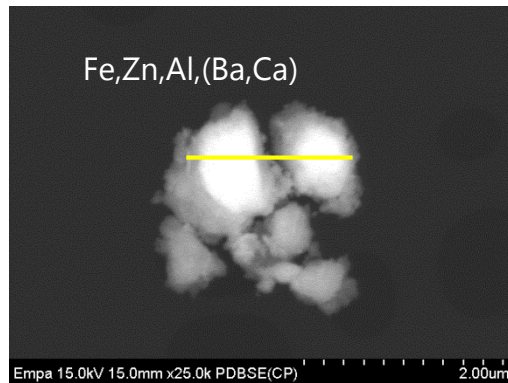

# Aggregates consist of numerous smaller particles

SET 1

STEP 7 836nm

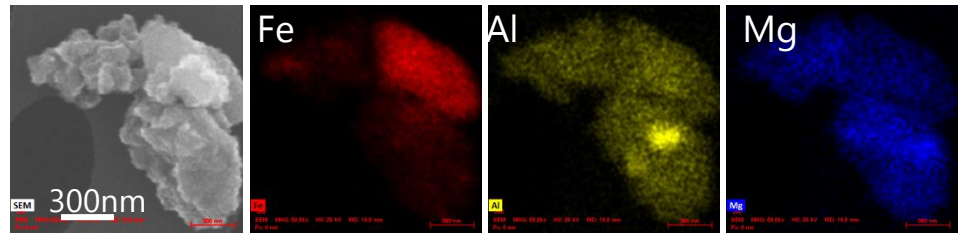

Smaller amounts of Sn, Ti, Cr

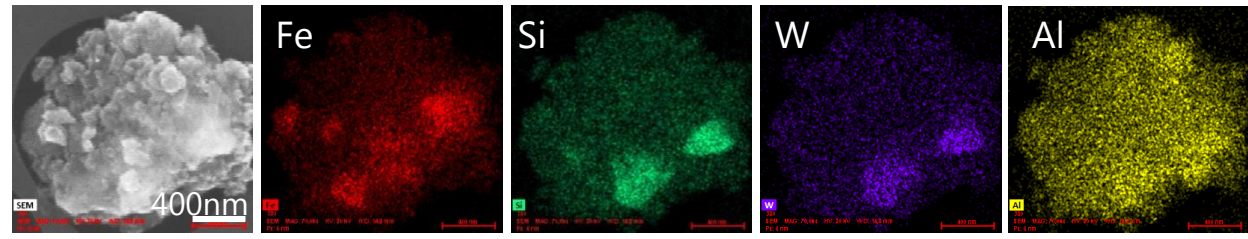

Smaller amounts of Mg, Ti, Cr

SEM SE images of two aggregates and element mapping of the most encountered elements (mapping duration 5min)

Aggregates are irregular and have rounded outlines  
Fe, Si, Al, Mg and Sn; W, Ti and Cr are usually locally  
enriched; small amounts of Ni and Ca occur also; C  
has been identified in a bigger particle; Bi was  
detected in one case

SET 1

STEP 8 1327nm

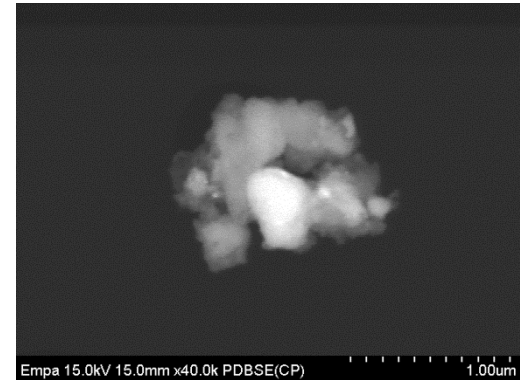
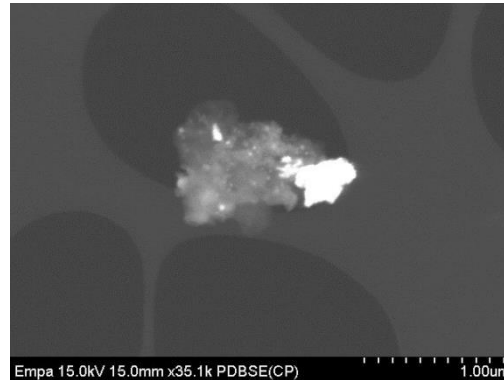
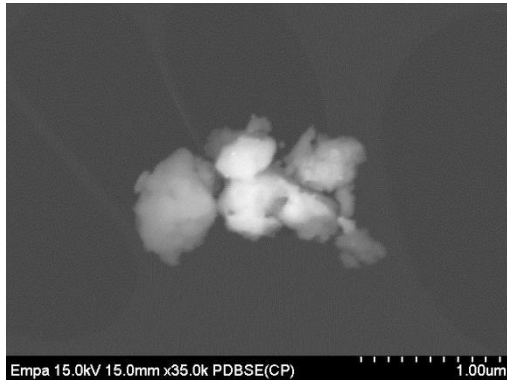

# Typical example for an aggregate

SET 1

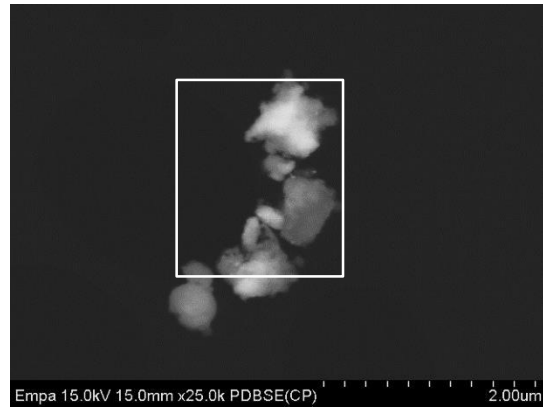

STEP 8 1327nm

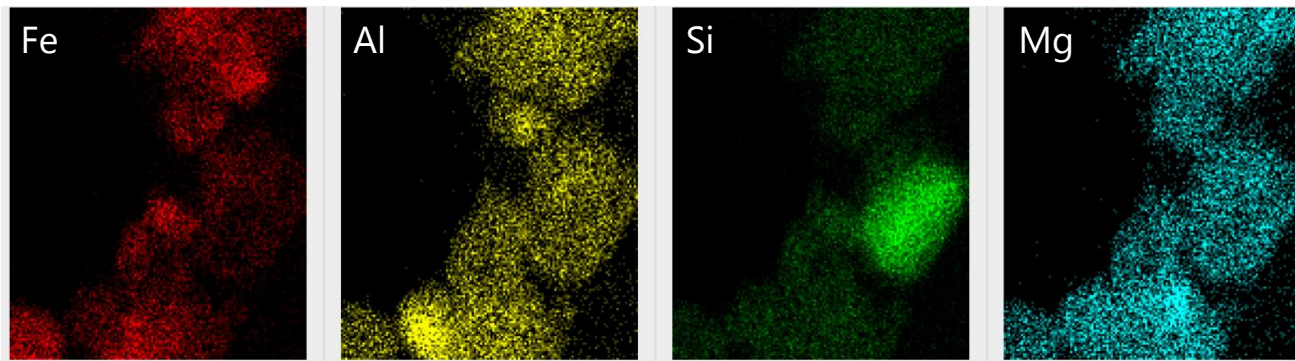

# Example of coexistence of Al and Mg

SET 1

STEP 9 2086nm

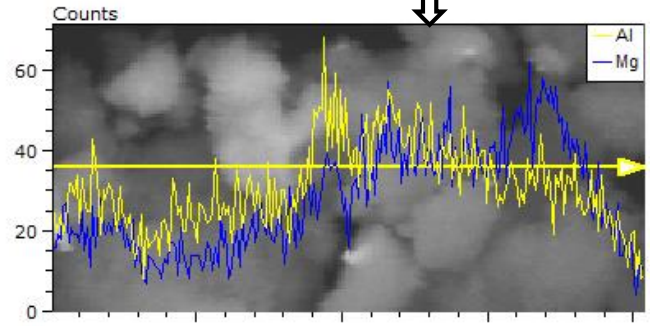
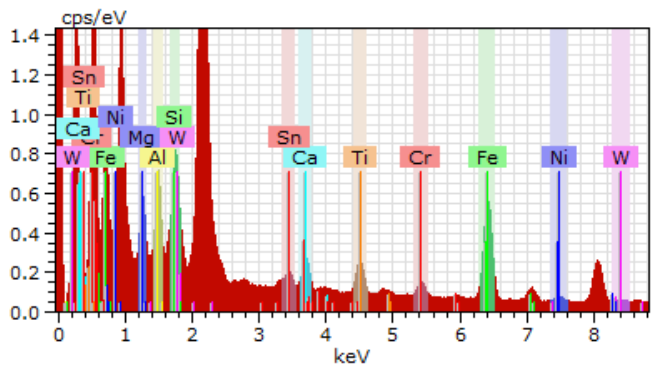
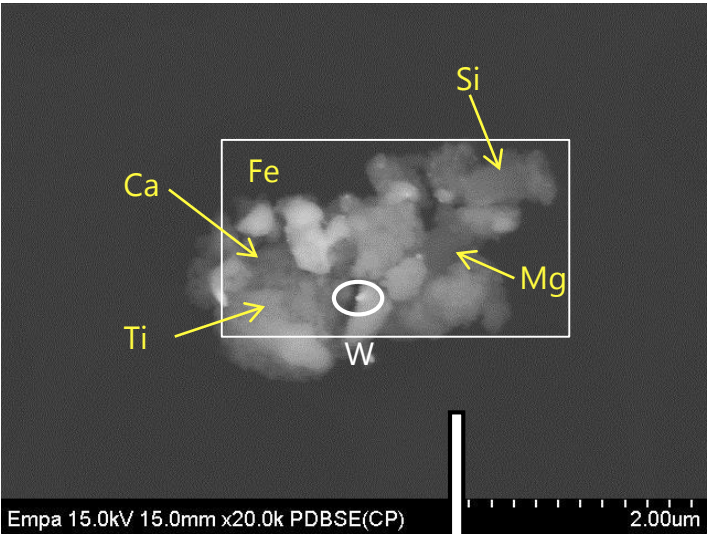
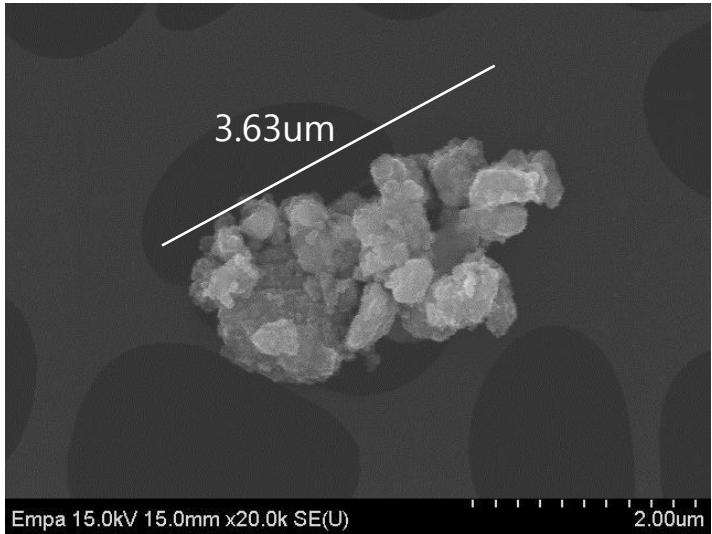

# Examples of coexistence and separate element distribution

SET 1

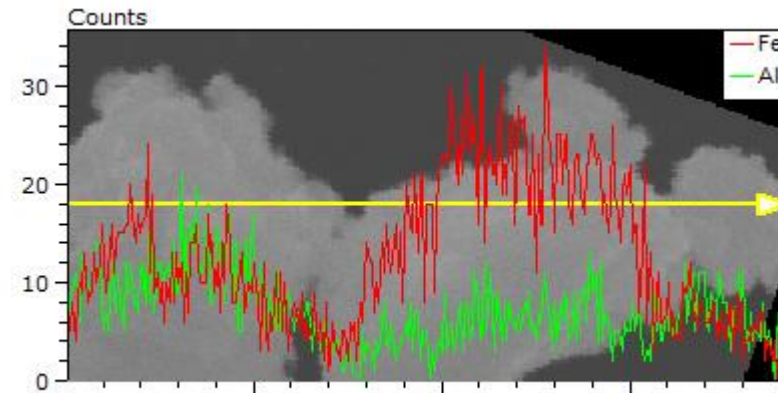
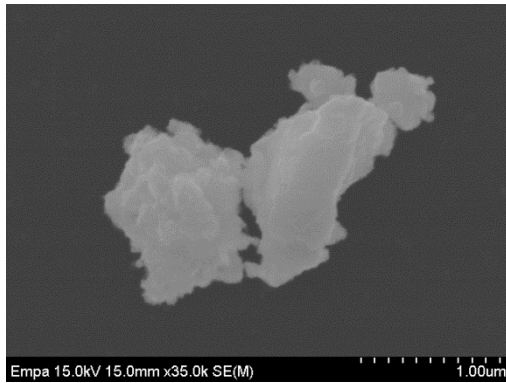

STEP 9 2086nm

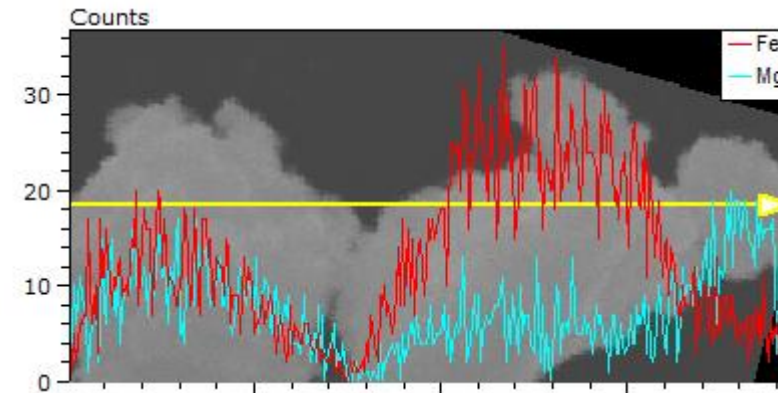
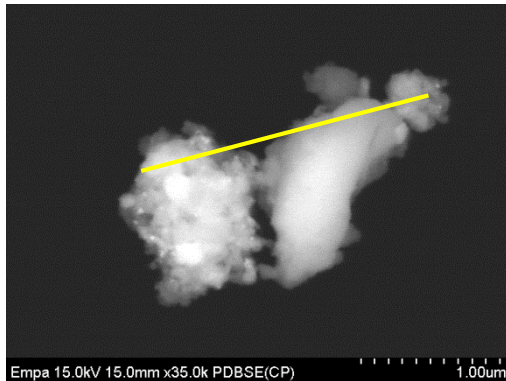

# Larger particles confirm the findings

SET 1

STEP 10 3278nm

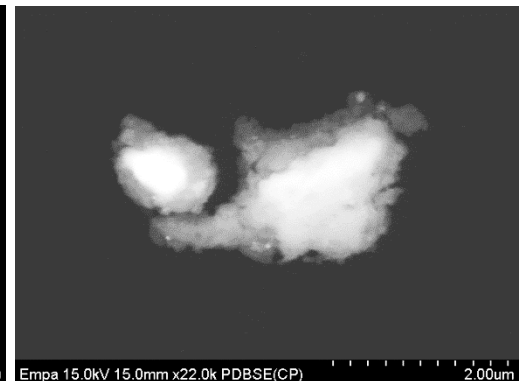
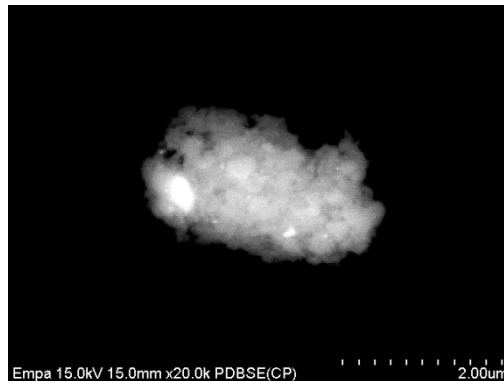
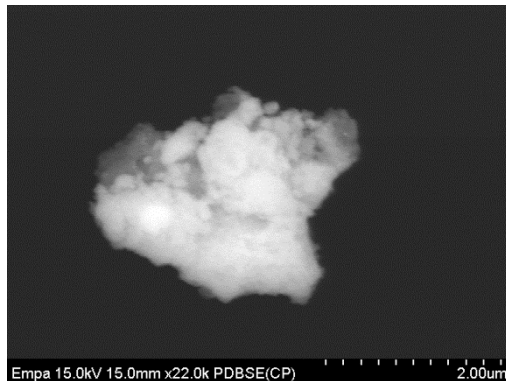
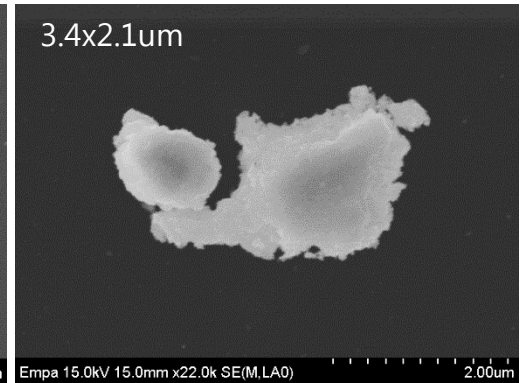
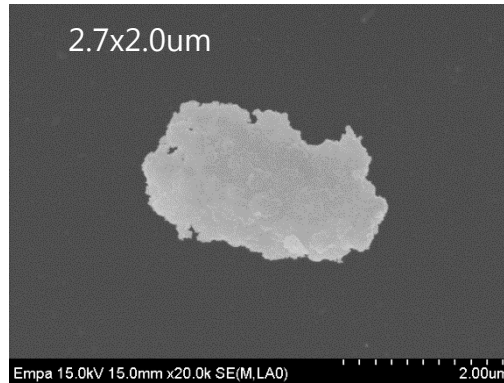
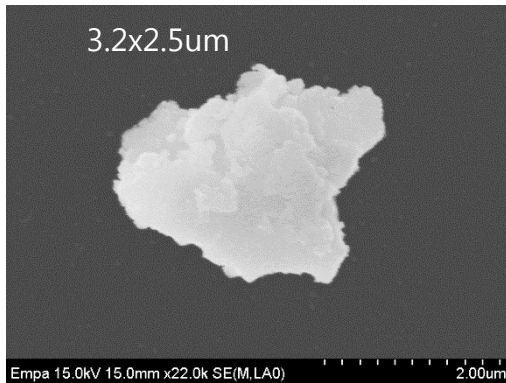



Abundant, very thin particles <30nm occur, some of the largest among the small particles give a weak (questionable) EDX signal of Al, Mg, Fe, soot identified

SET 2

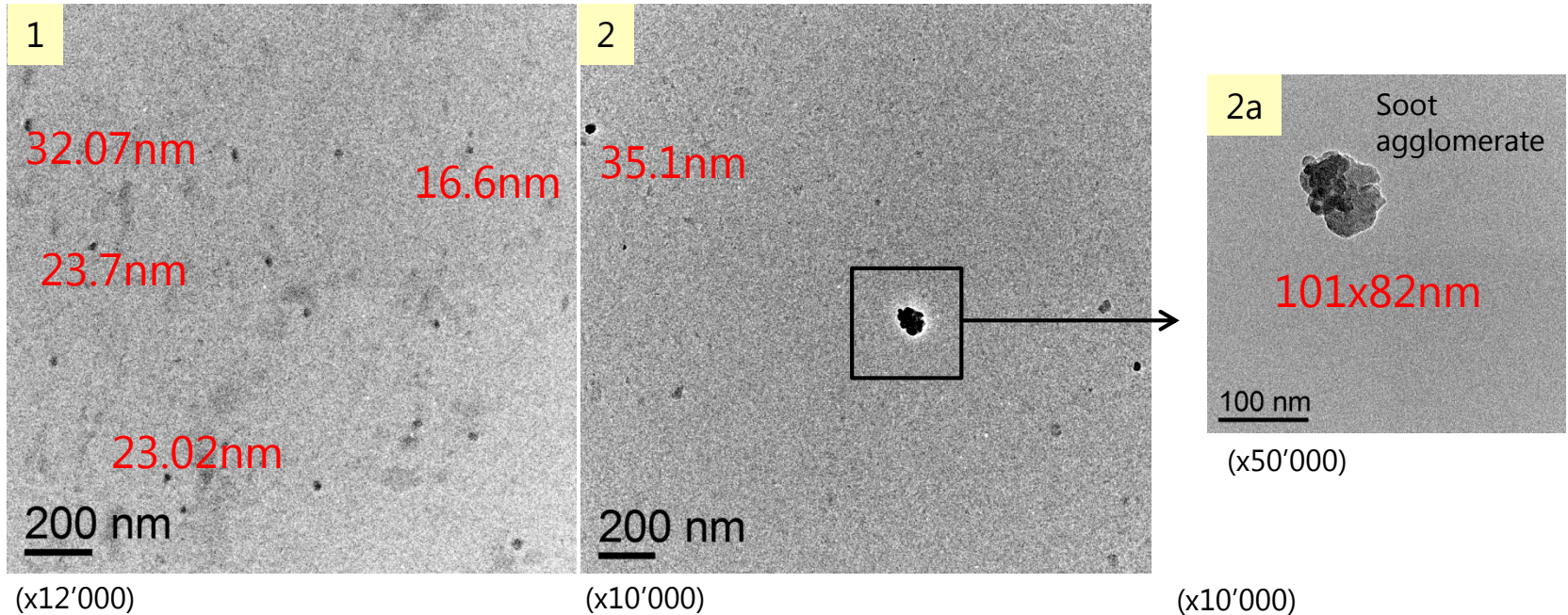

STEP 1 (45nm)

ca. 30-40nm large agglomerates consist of smaller particles (~10nm); some of the agglomerates have a soot structure characterized by carbon-lamellae

SET 2

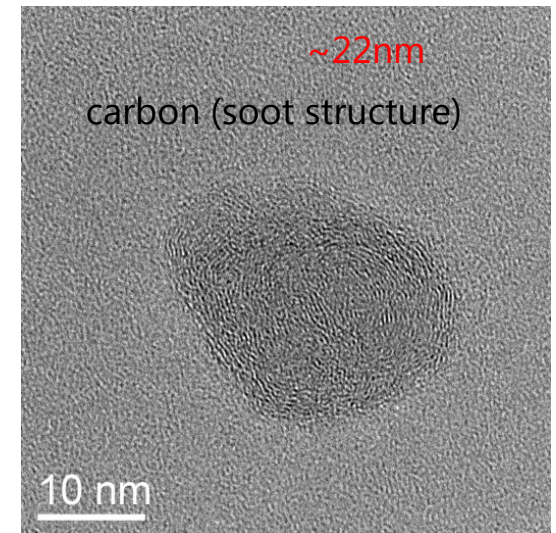
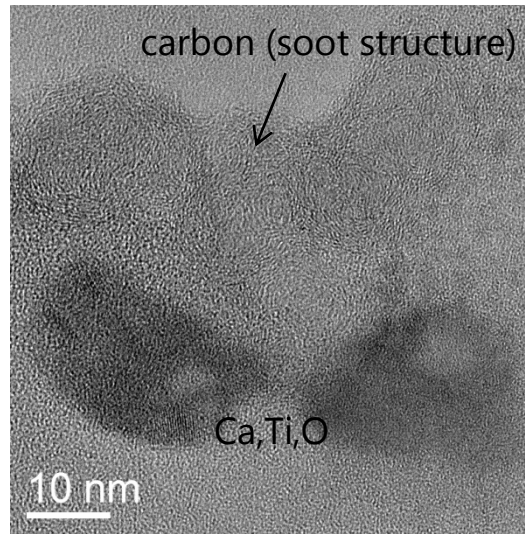
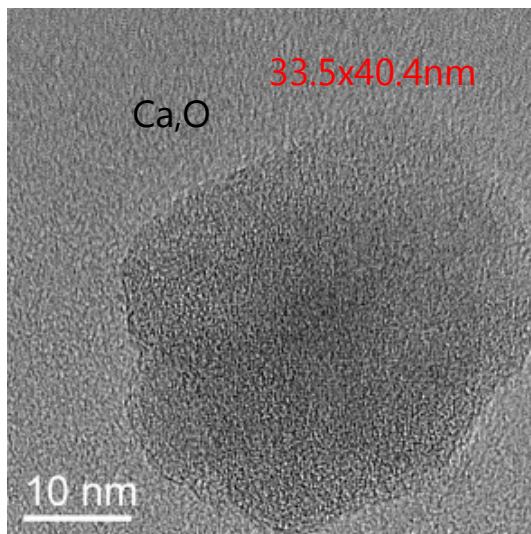

STEP 1 45nm

Composite aggregates of larger sizes (>50nm) consisting of mostly Fe; also Ti, Al, Mg, Si, Ca, P, K, Sn, Zn, S, Zr and Na were found; Carbon material (?soot) often coexists with metal phases

SET 2

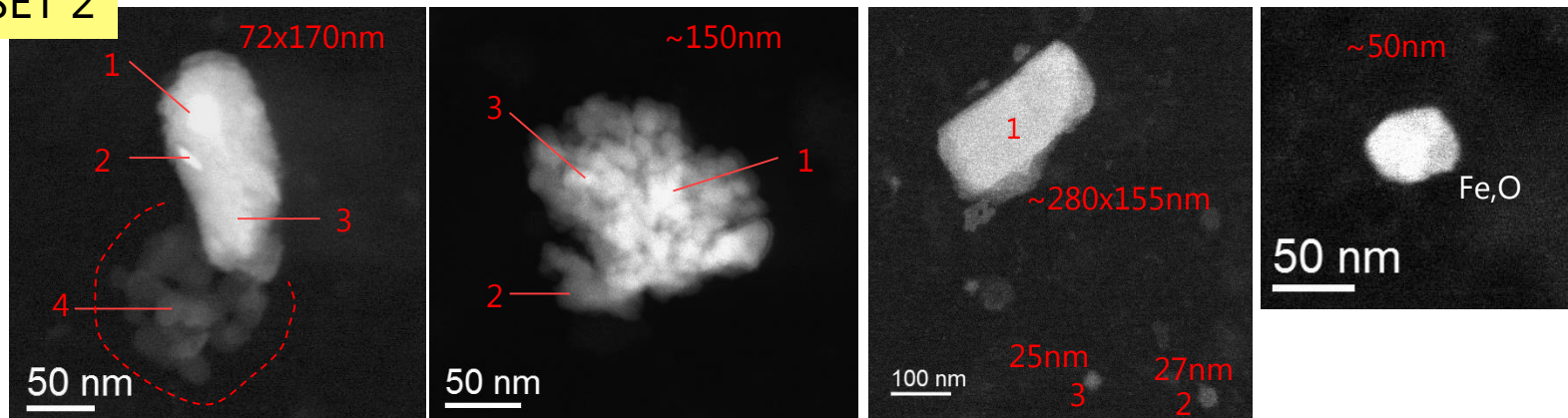

1: Fe,Ti,Zr,(Ca),O; 2: Fe,Ti,Ca,S,O  
3: Fe,Ti,Ca,S, Zr,O; 4: no detectable elements (carbon?)  
(dashed encircled area may represent a soot agglomerate).

1: Fe,Mg,Zn,S,Sn,O;  
2: Fe,Zn,Mg,O;  
3: Fe,Zn,S,Sn,Mg,O

1: Al,(Si?)O; 2: Al,(Si?),O;  
3: K,P,Na,(Si?),O

STEP 1 45nm

Dark field STEM images of particles and agglomerates. Numbers mark the approximate sites of EDX analyses. The brightness correlates with atomic weight and/or particle thickness.

# Multi-phase aggregates of crystalline material, Fe, Ti, S, Ca, K, and Zr were found by EDX

STEP 3 141nm

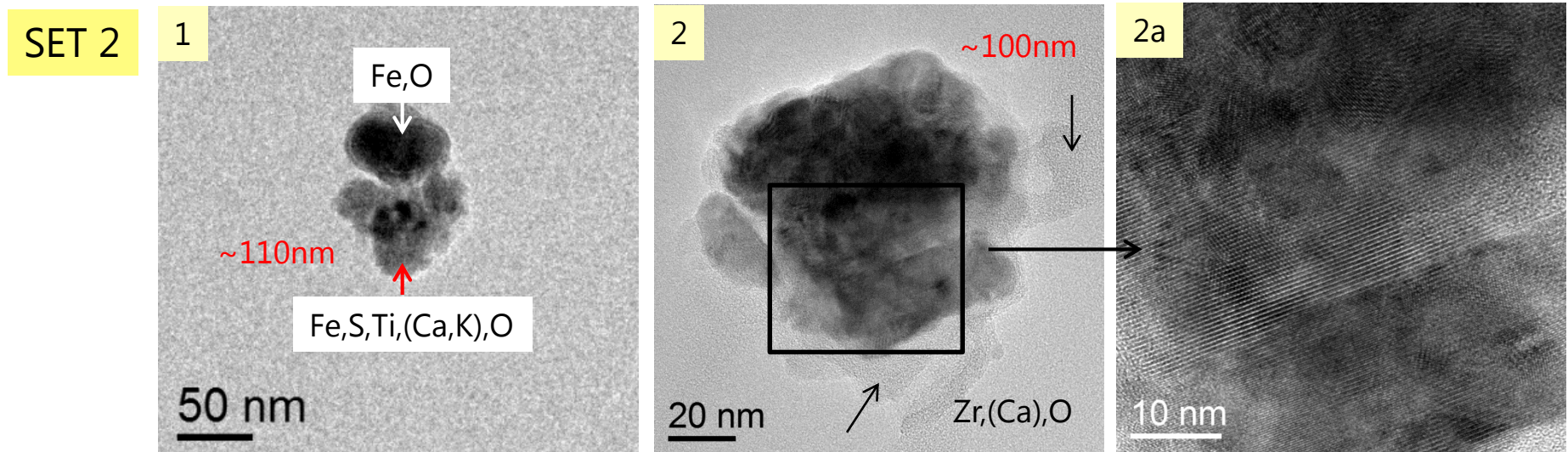

TEM (1, 2) and HRTEM images of particles with example of crystalline structure (2a; lattice fringes):

Heterogeneous aggregates Fe, Ti, Ca, Al, Si, Mg; some Sn, Zn, Mn; irregular and nearly equidimensional; the particle outlines are often rounded

SET 2

STEP 5 340nm

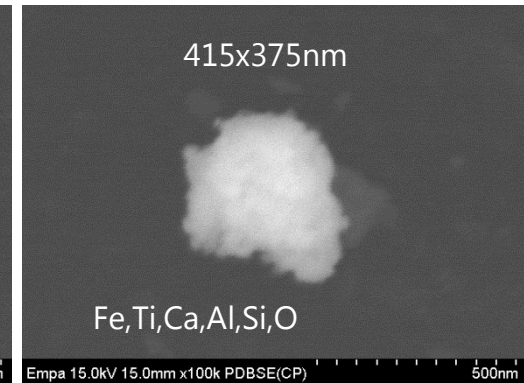
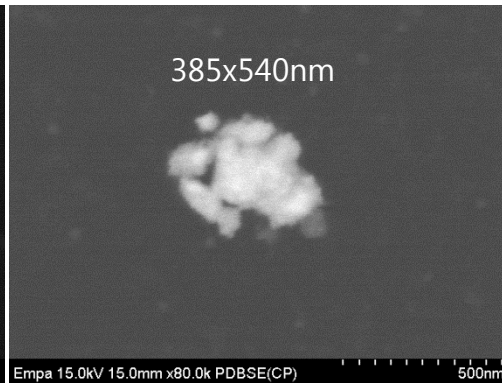
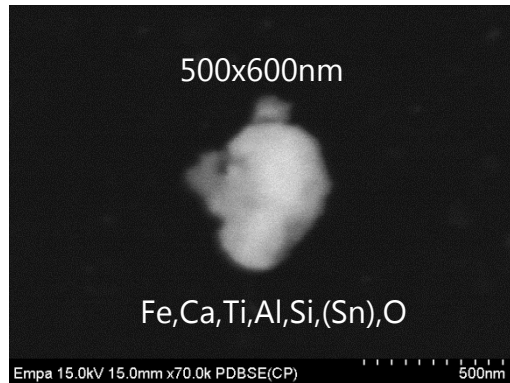

STEP 6 530nm

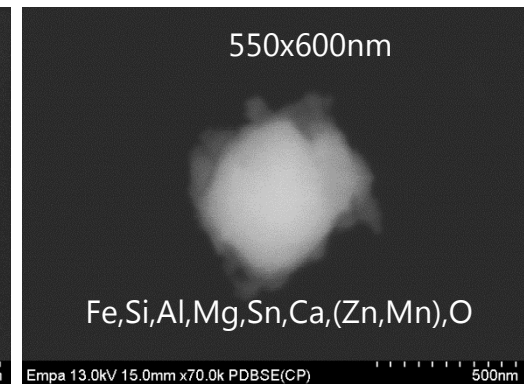
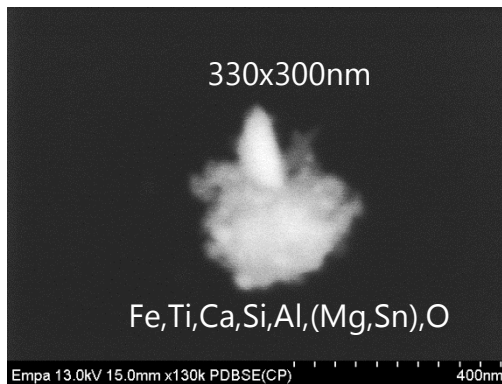
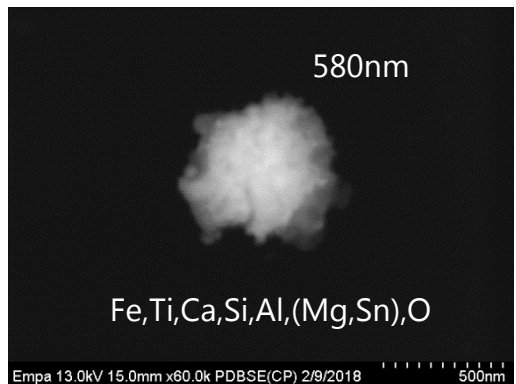

Heterogeneous aggregates Fe, Ti, Ca, Al, Si, Mg, Zr; some Sn, K; Sb and F were found rarely; irregular and nearly equidimensional; the particle outlines are often rounded

SET 2

STEP 7 840nm

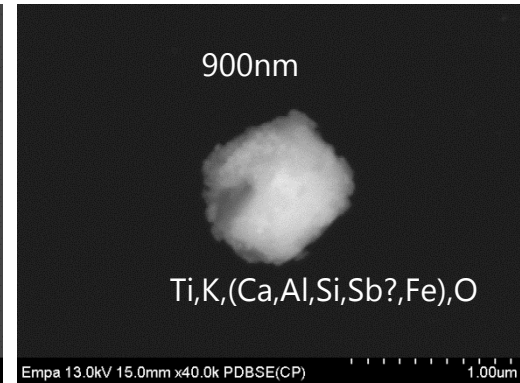
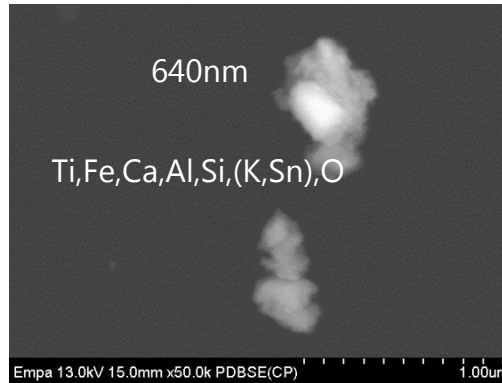
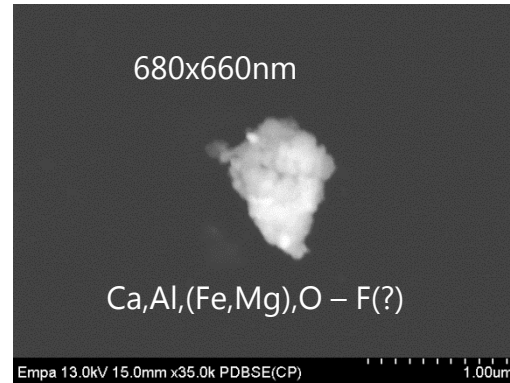

STEP 8 1327nm

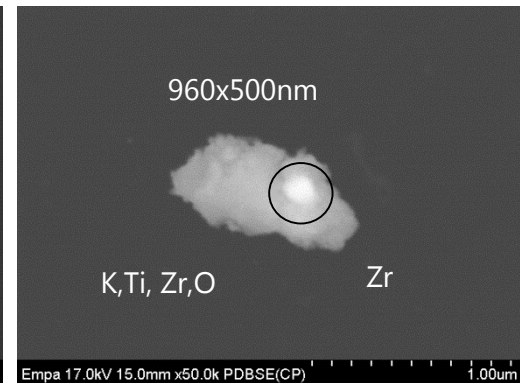
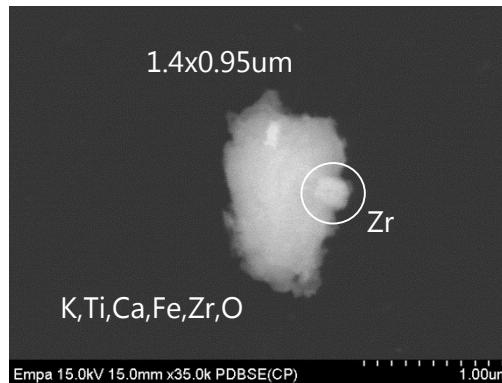
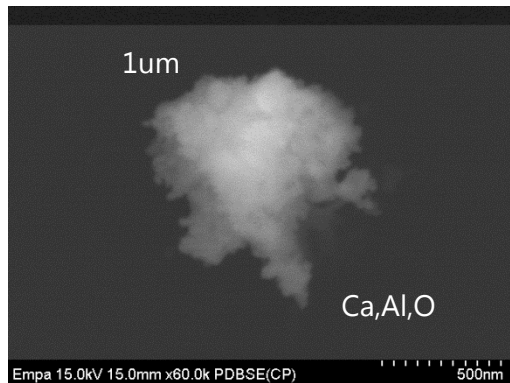

SEM BSE images of different aggregates.

# Polyphase aggregates (> ~4 $\mu$ m) Fe, Ti, Ca, Si, Al, Mg, K, C, and less Sn

SET 2

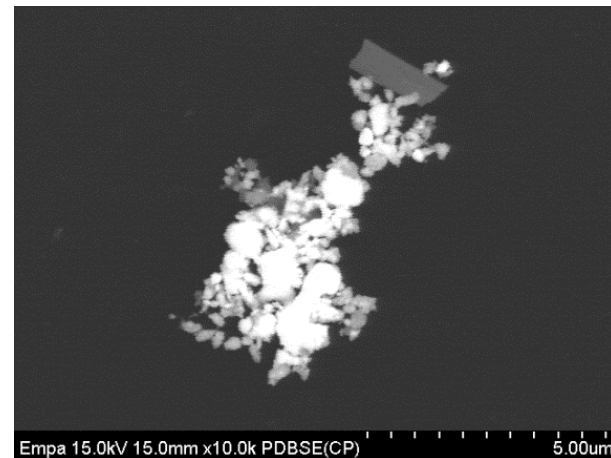
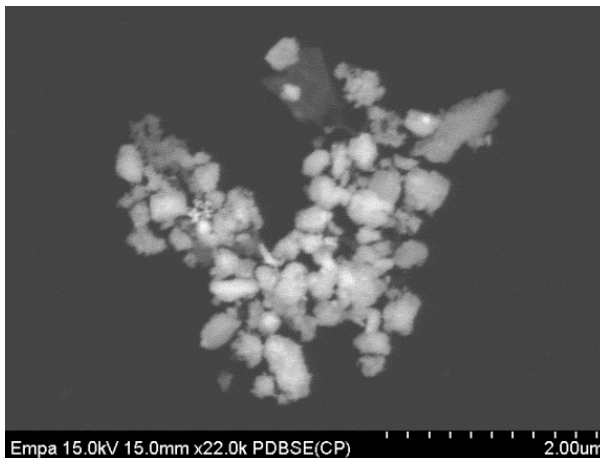
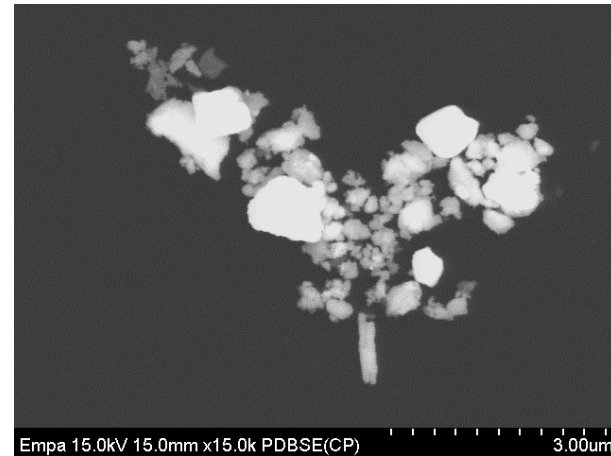
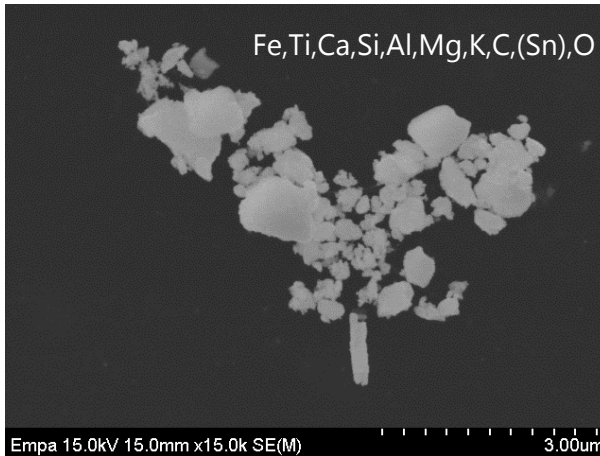

Different element, element combinations K, Al, C, Ti, Fe, Ca, Si, and minor Sn, Mg.

SET 2

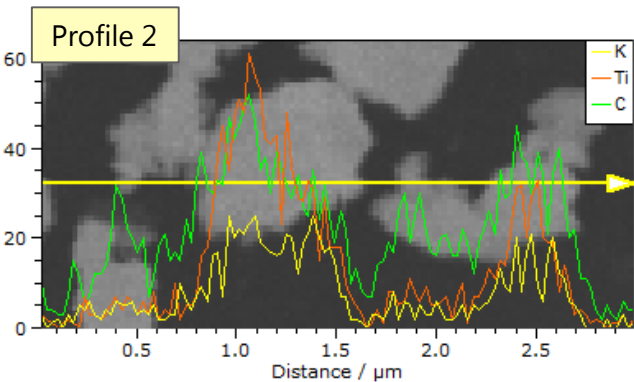
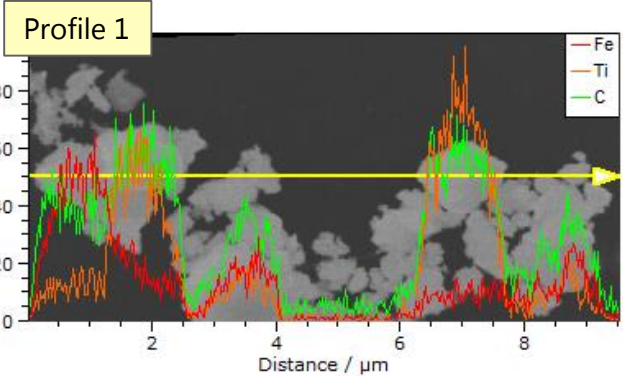
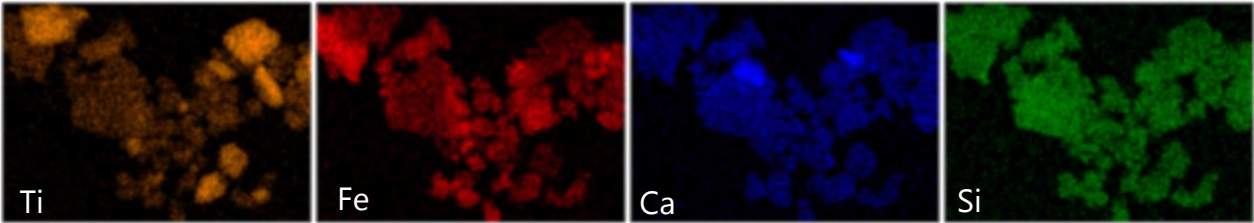
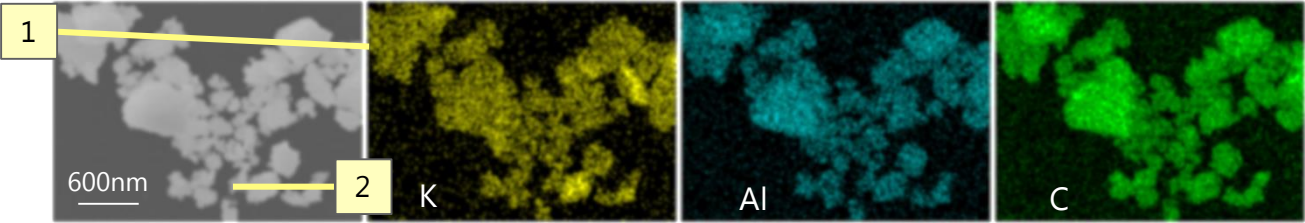



The particle constituents of the mapped aggregates are composed of different elements or element combinations: Fe, Ti, Ca, K, Si, C and less Al, Sn, Mg.

SET 2

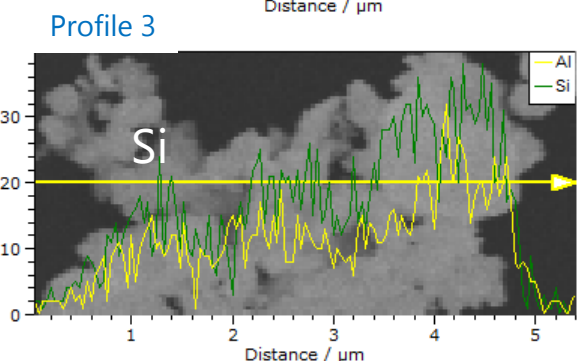
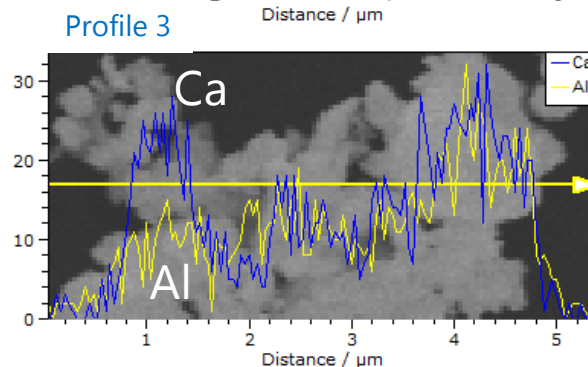
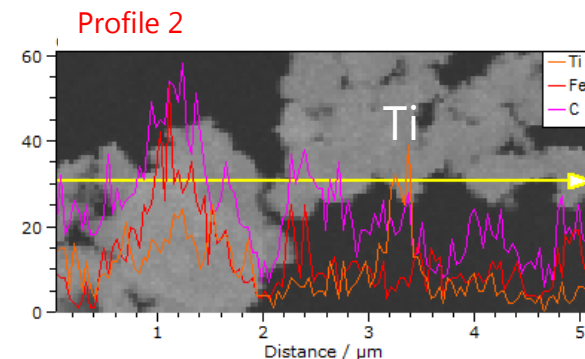
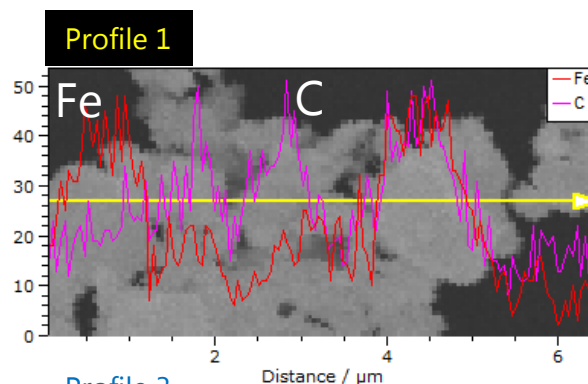
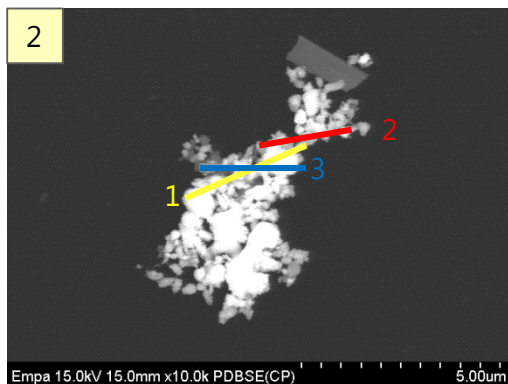

BSE images and element distribution profiles of a ~7μm long aggregate consisting of particles with different size and chemistry; the element profiles indicate coexisting (or not) elements in different particles.

Aggregate with prismatic to fibrous constituents composed of Ca, Si and traces of K, Al.

SET 2

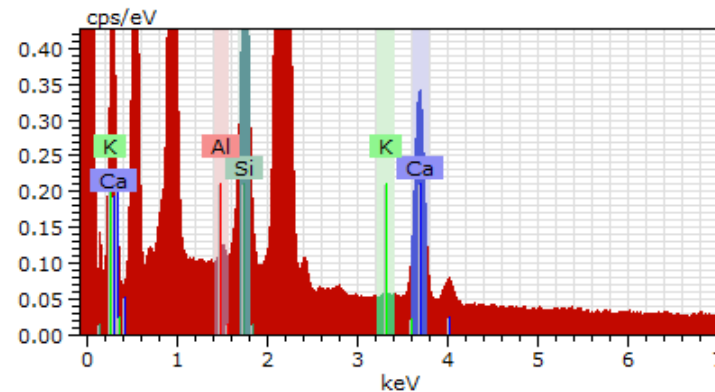
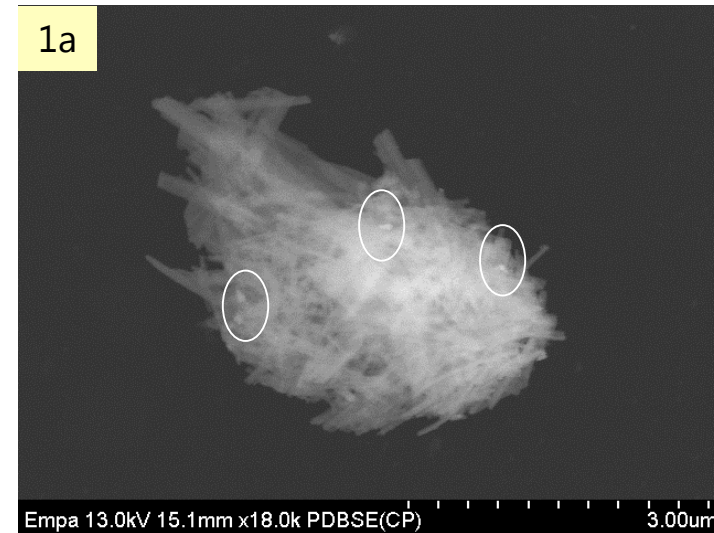
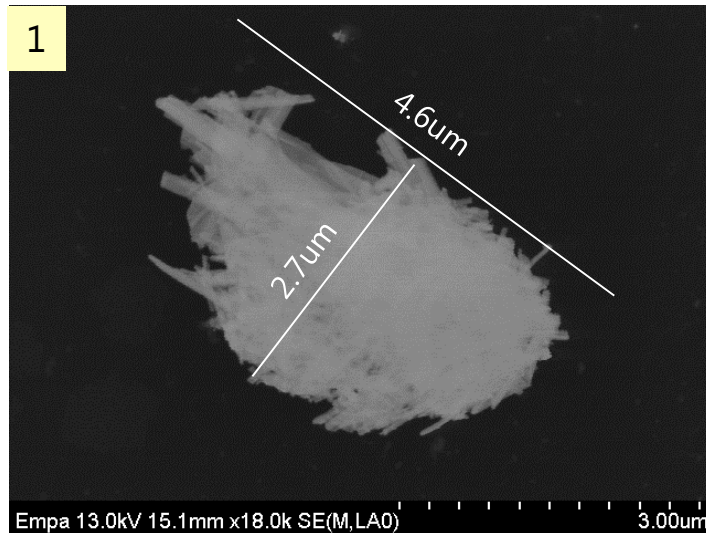

SEM SE (#1) and BSE (#1a) images of a Ca-Si-bearing aggregate; Bright 'spots in #1a (encircled) probably correspond to Zr-bearing particles.

- Particle sizes:
  - In the first four size classes ( $D_i < 220\text{nm}$ ) of both sets, abundant small particles ( $< 100\text{nm}$ )
  - In the first 2 size classes ( $< 85\text{nm}$ ) of both sets, the majority of the particles are  $< 20\text{nm}$
  - In both sets, particles occur as aggregates (a few tens of nm to a few  $\mu\text{m}$  large), made of constituents with different chemistry
- Particle shapes:
  - small size classes (steps 1 to 4): SET1 usually circular and very thin (disc-like) shapes; SET2 : circular and irregular shapes; also very thin
  - class 5 and larger: irregular, nearly equidimensional, elongated, with rounded outlines; similar shapes for both sets
- Particle chemical composition
  - Very small particles ( $\sim 20\text{nm}$ ) in SET1:  $\text{Ca} \pm \text{Fe}$ ; SET2:  $\text{Ca} \pm \text{Ti}$
  - Larger aggregates ( $\sim 70\text{-}250\text{nm}$ ) SET1: most encountered often Ca, also Al, Mg, Fe, Sn, Ti. SET2: mainly Fe, Ti, also Al, Mg, Ca, Si
  - Agglomerates probably consisting of Carbon particles with a soot internal structure were identified in the small size classes (steps 1 and 3) of Set 2
  - Large size classes (class 5 and larger;  $> 340\text{nm}$ ):
    - Set 1: Fe, Al, Sn, Mg, Si, Cr, W and smaller amounts of Ti, Ni and Ca. Bi, Ba, C, as well as Zn were analysed in a few aggregates
    - Set 2: Fe, Ti, Ca, Si, Al, K, Mg, and less Sn, Zn, Cr, Zr, C(?) and Mn; Ba, W and S were rarely analysed; Sb, Bi and F (F together with Ca) were found –individually- in one case