

# Definition and testing of a Direct Vision Standard for Trucks

Loughborough University Design School (LDS): Design Ergonomics Research Group  
Research Sponsored by Transport for London

Dr. Steve Summerskill – Senior Lecturer in Industrial design and ergonomics

Dr. Russell Marshall, Dr Abby Paterson, Antony Eland, James Lenard, Steve Reed

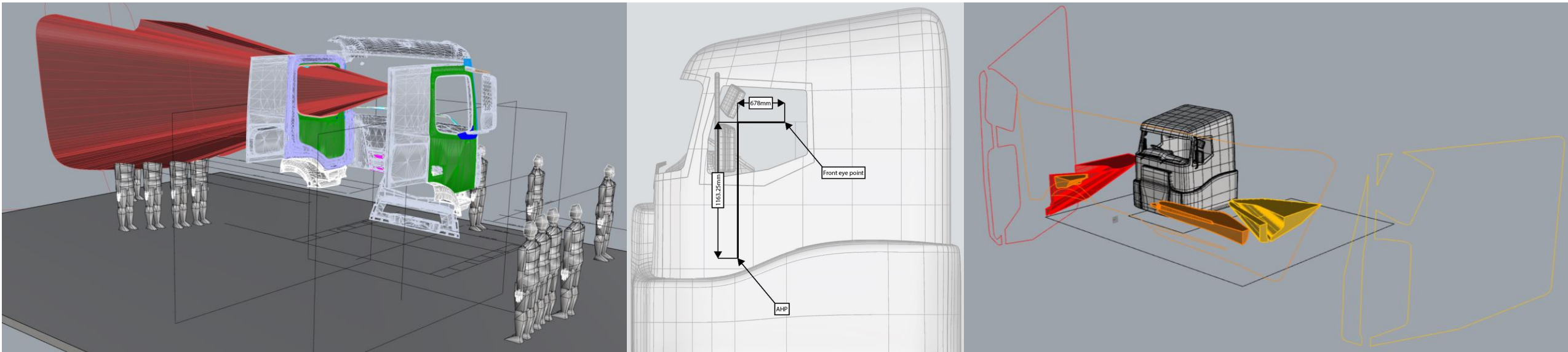

# Contents

---

- The aim of today's presentation is to present the methodology that we have defined over the past 2 years
  - How the project was defined?
  - Previous experience of the LDS team
  - Accident data analysis for the UK & London
  - The starting point for the project
  - Defining the DVS
  - Sample of vehicles used
  - The use of VRU simulations as a real world measure
  - The results
  - Using the DVS to improve safety in Europe

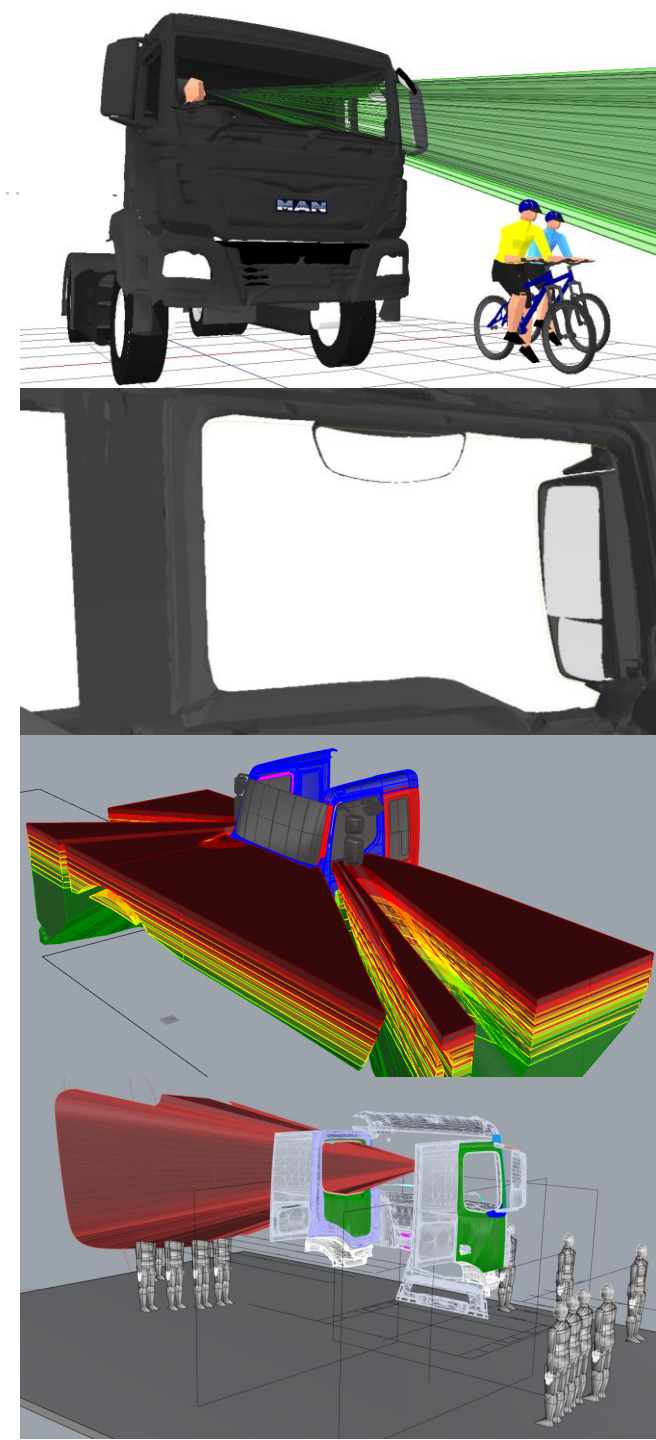

## How the project was defined.....

- Truck drivers must use the combination of windows and mirrors to see what is around a truck
- **But** there is **no standard** that governs what should be able to be seen directly through the windows, only the coverage of mirrors is standardised
- Currently the task of gaining situational awareness is supported by the use of **six mirrors** which causes problems in high workload scenarios
- By defining a Direct Vision Standard **TfL** aims to foster the adoption of vehicle designs with a minimum defined direct vision performance
- Evidence for the requirement is shown in the TfL slide deck
- The direct vision standard will do this using a **5 star rating system**
- **The process of defining a 5 star rating scheme is the focus of this project**

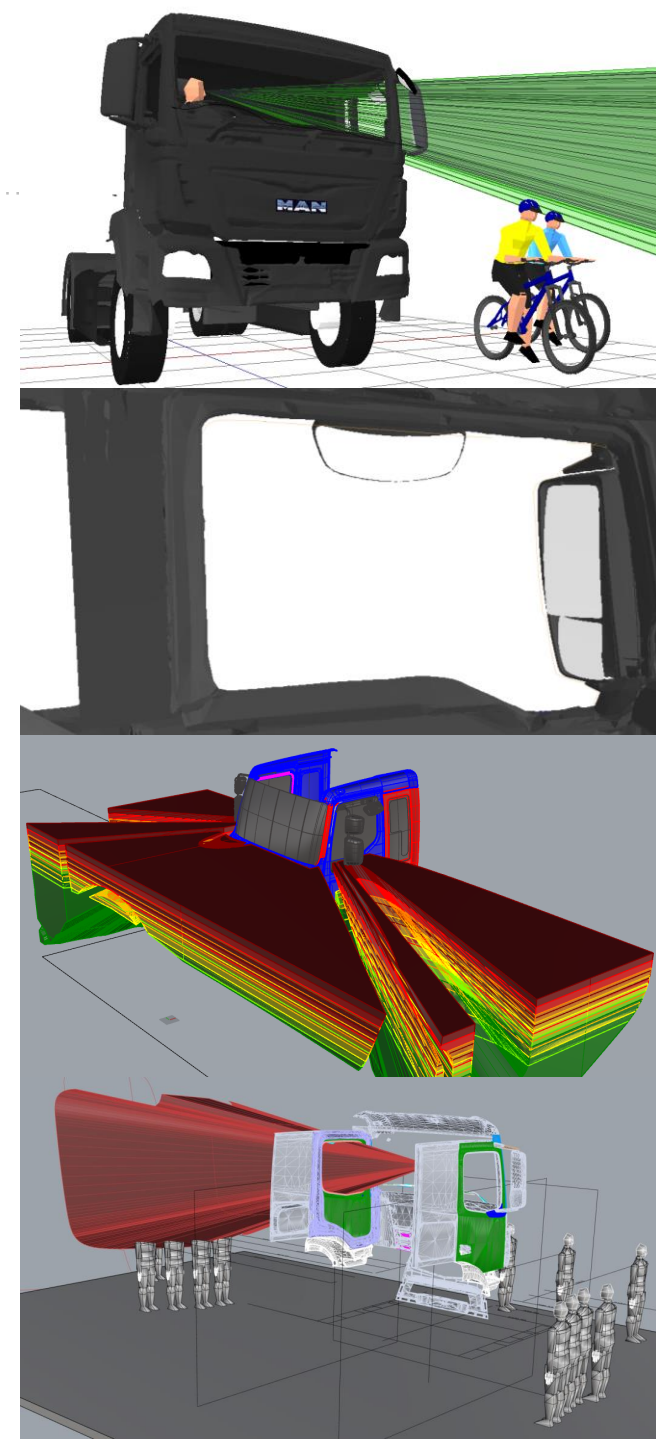

---

Previous experience of the Loughborough Design School (LDS) team – leading to the definition of the need for a Direct vision Standard (DVS)

## Background work – DfT Project 2010-2012

### Using Digital Human Software to simulate and quantify blind spots

- The Loughborough Design School (LDS) team used a [method to visualise and quantify blind spots](#) in a project for the UK Department for Transport (DfT) for six HGVs
- This technique uses Digital Human Modelling software to visualise the volume of space that can be seen by a driver in the combination of [direct vision](#) (through windows) and [in-direct vision](#) (through mirrors)

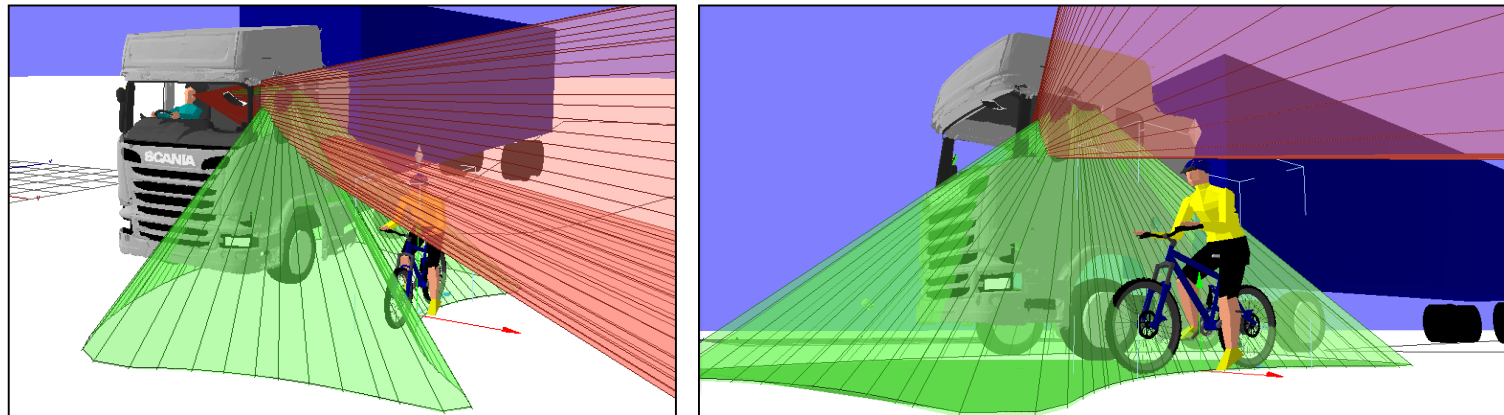



# Background – TfL Project 2013-2015

## Assessing the vehicle fleet to determine the differences and highlight blind spot design features

- 19 vehicles modelled and tested to determine their blind size variability and design features which cause that variability.

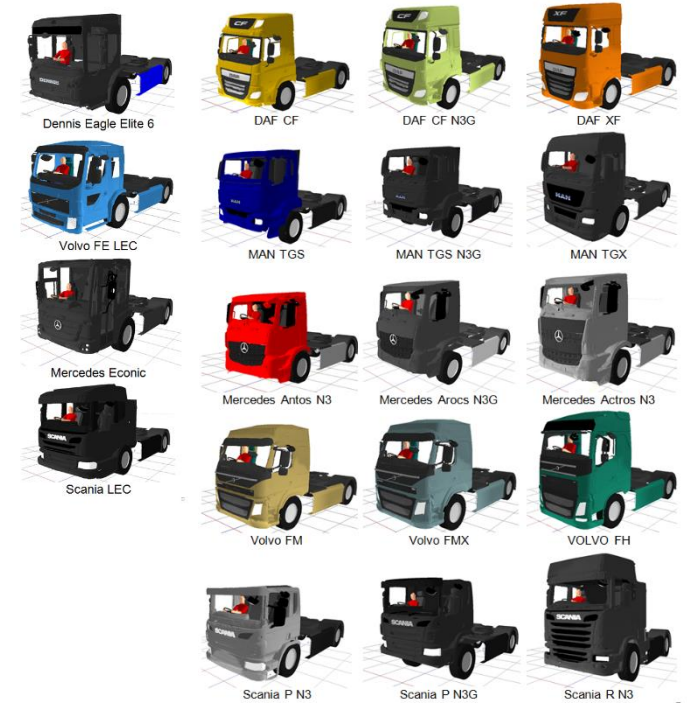
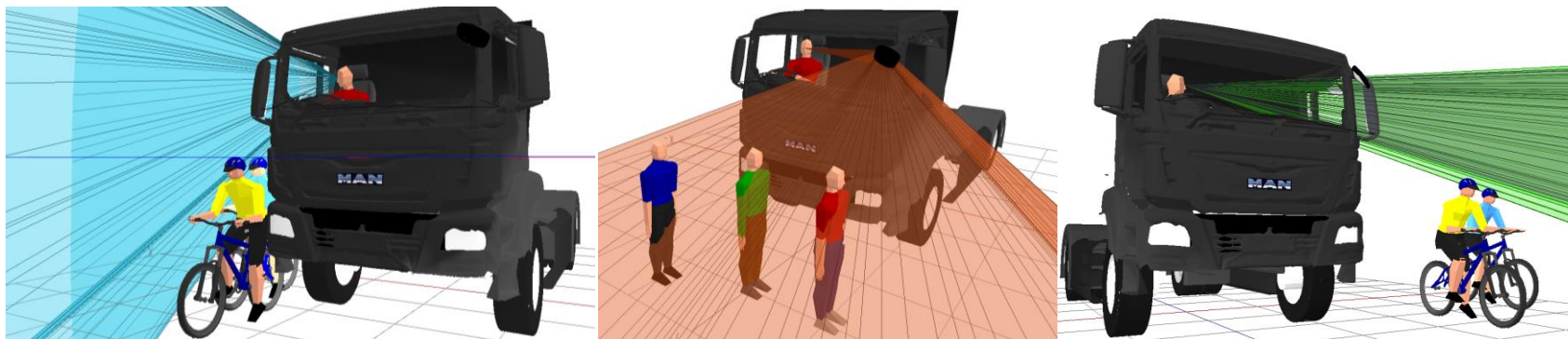

Nearside Cyclist Obscuration (rear) - 50th %ile Male Driver

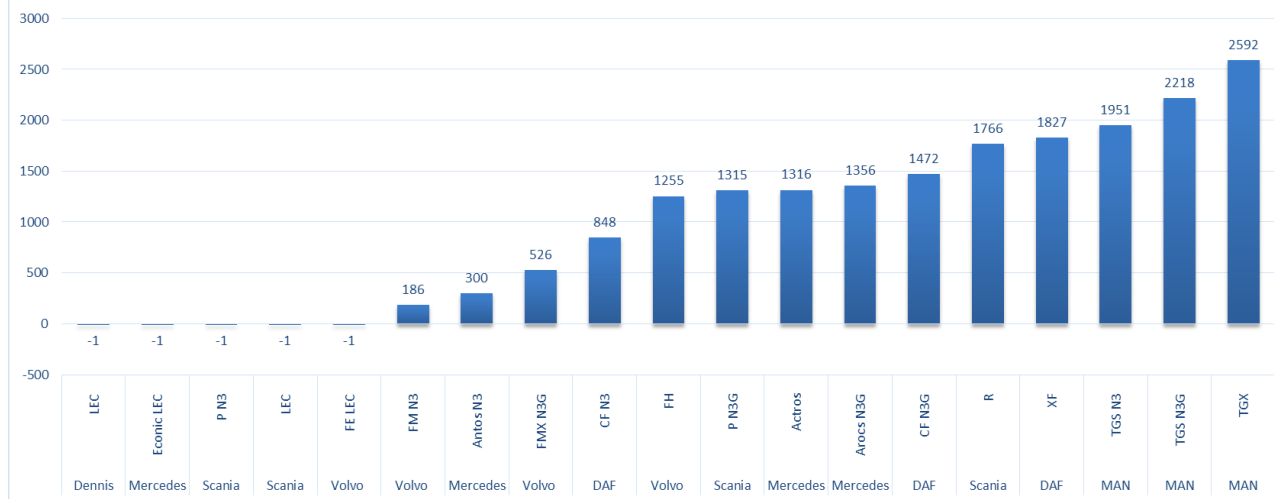

# Results TfL Project 2013-2015 – Example of exploring the important design variables

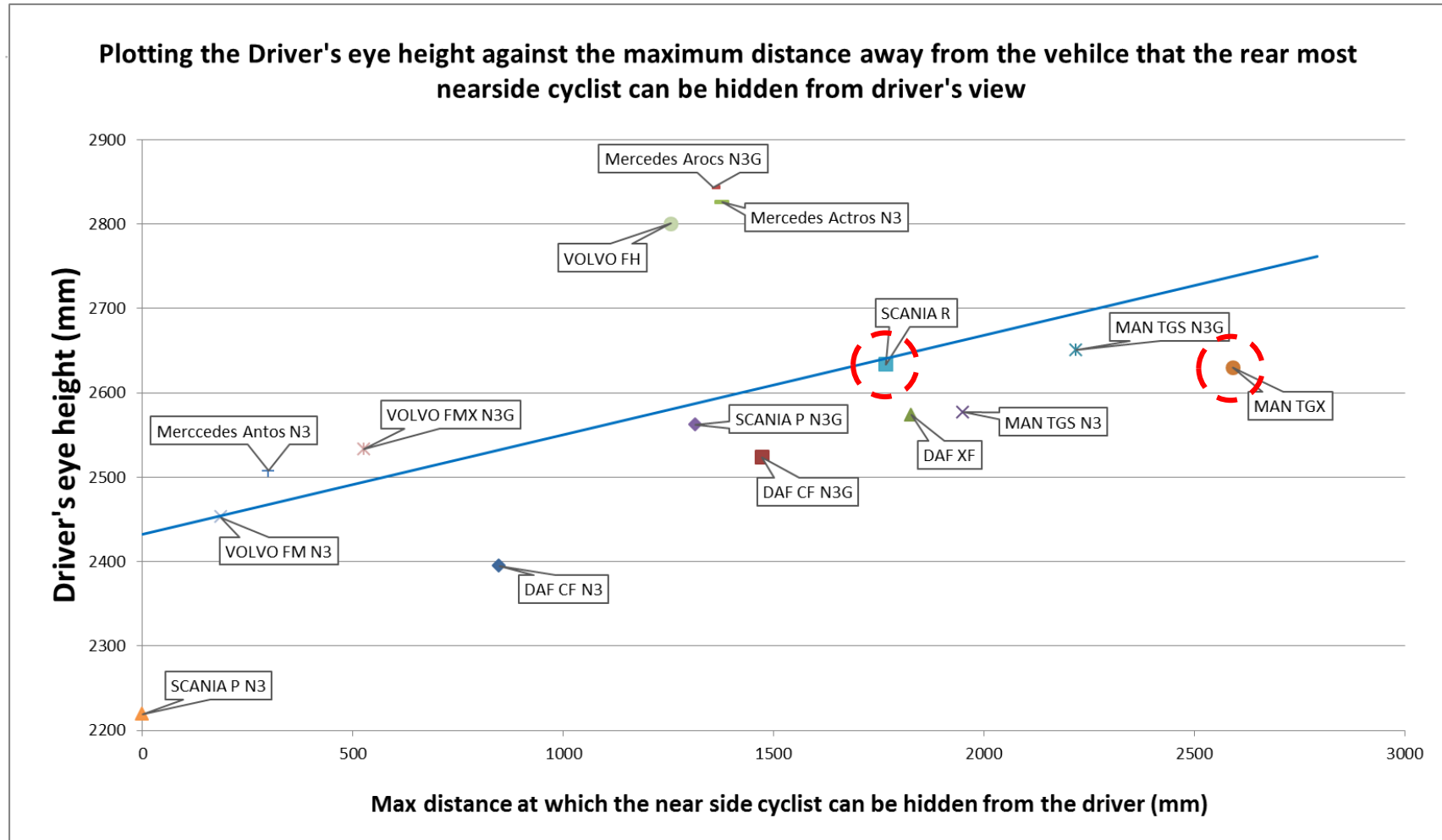

- ***This means that there is a link between the eye height of the driver above the floor and the maximum distance that a cyclist can be hidden to the near side***
- There were however some anomalies which required further investigation to allow key design features to be identified



## Results TfL Project 2013-2015 – Example of exploring the important design variables

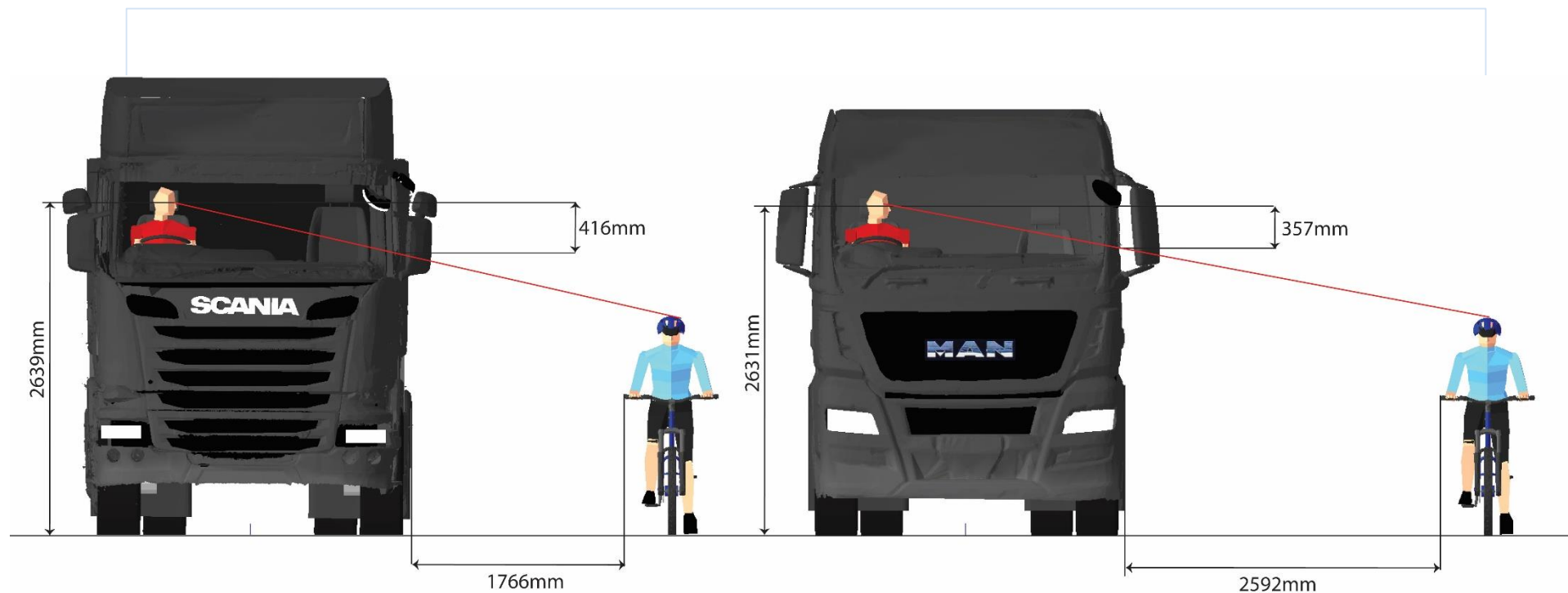

- MAN TGX has a lower driver eye height above the ground, but the cyclist is fully hidden further away from the vehicle when compared to the Scania R (826mm difference)
- This is due to the drivers eye point being relatively higher above the window sill in the Scania R

## Results TfL Project 2013-2015 – Example of exploring the important design variables

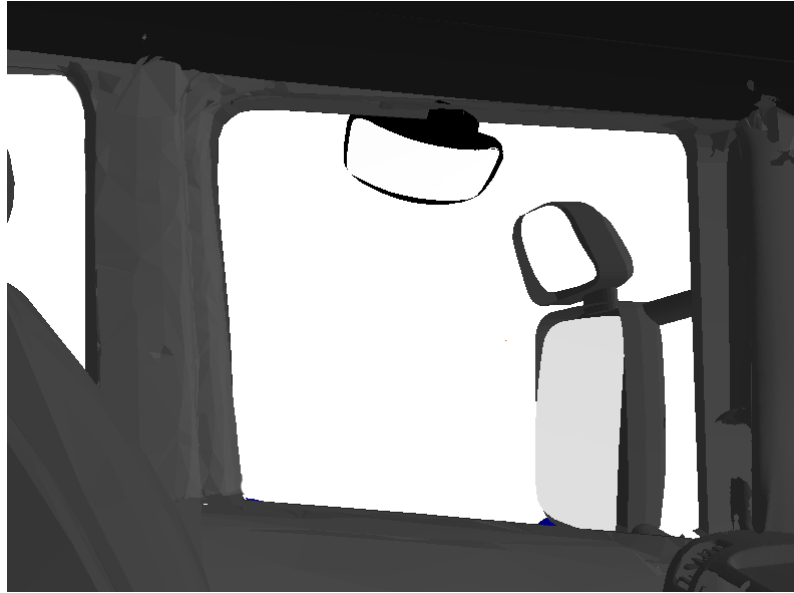

Scania R

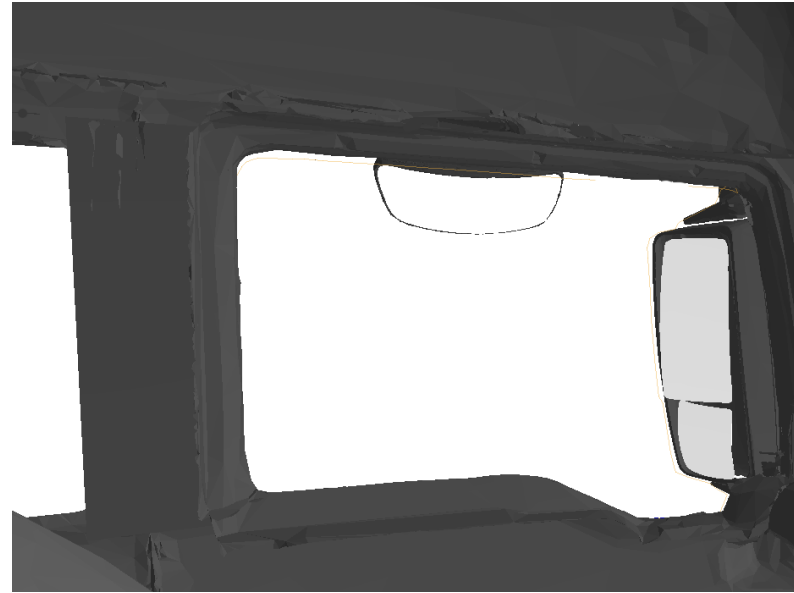

MAN TGX

- Driver's eye views of the passenger window
- The higher window sill at the rear edge of the window in the MAN TGX reduces the field of view in this critical area

## Results TfL Project 2013-2015 – Key issues identified

- The project highlighted a number of examples which showed variability in direct vision performance and issues with the use of indirect vision
- The following features were identified;
  - The location of the driver in the cab with respect the windscreen
    - Better performance when the driver was further forward in the cab
  - The location of the driver in the cab with respect the side window bottom edges
    - Eye point higher in relation to the window bottom edge is better
  - The design of window apertures (see example)
  - The width of the cab (narrower is better)
  - The requirement for the class V and Class VI mirrors to be used simultaneously to gain situational awareness of VRUs close to the A-pillar on the passenger side of the truck
  - The ability of the mirror mounting structure to hide VRUs from the view of the Class V mirror
- Direct vision is the primary methodology by which drivers gain situational awareness (until fully reliable class 3/4 automated vehicles enter the market)
- And yet direct vision is not regulated in the design of trucks - these issues led to the recommendation for a direct vision standard
- This project led the LDS team to recommend a DVS to TfL

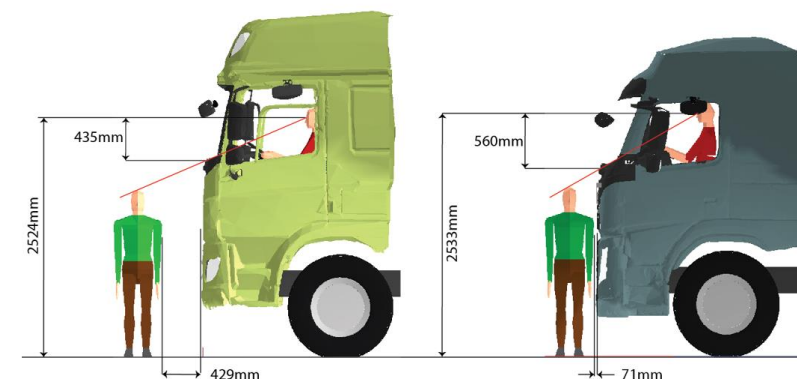
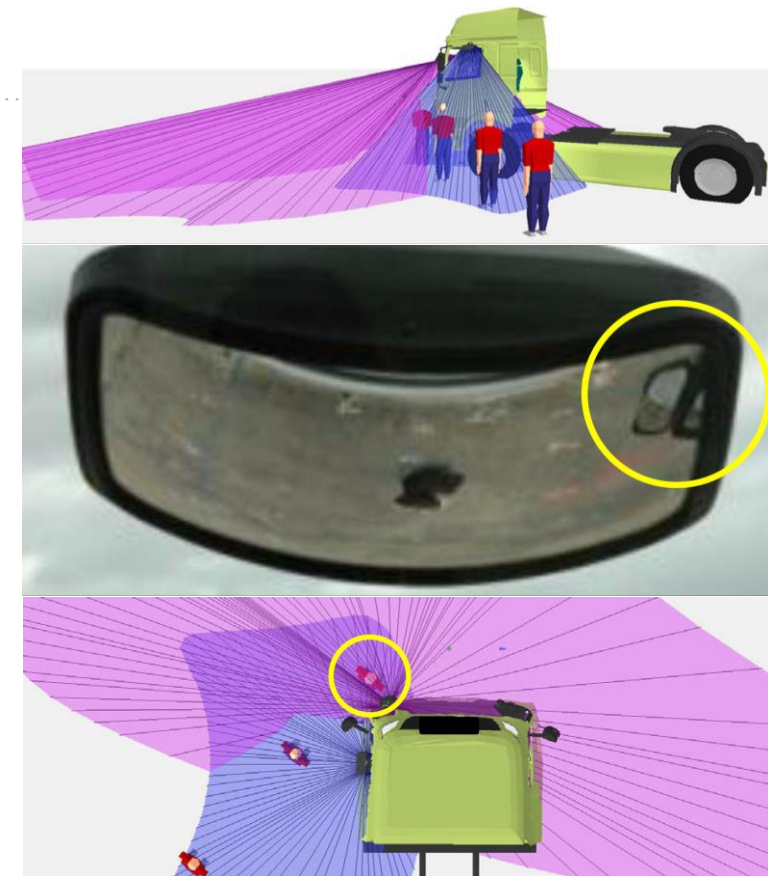

# The case for improving direct vision – research from other bodies

## Wilkie and Mole 2017 – simulator study to examine effects of direct and indirect vision on VRU detection

### Indirect vision has a 0.7s slower response time

Risk increases with speed as more distance travelled

Extra distance in urban environment especially high risk

Speed	Distance
15 mph	4.7m
10 mph	3.1m
5 mph	1.5m

### Bigger collision risk

Indirect vision resulted in increased incidence of simulated pedestrian collisions by 23%

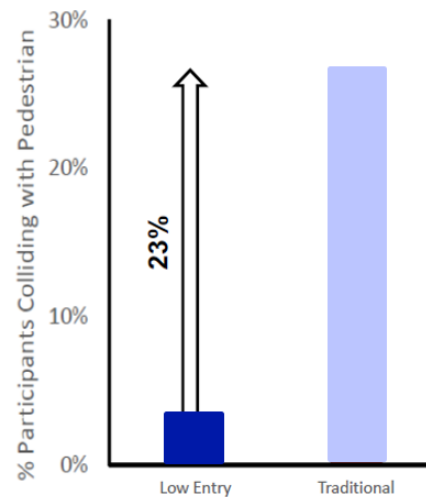

### Limits to technology benefits

Drivers processing a cognitive task increased simulated collision by 40%

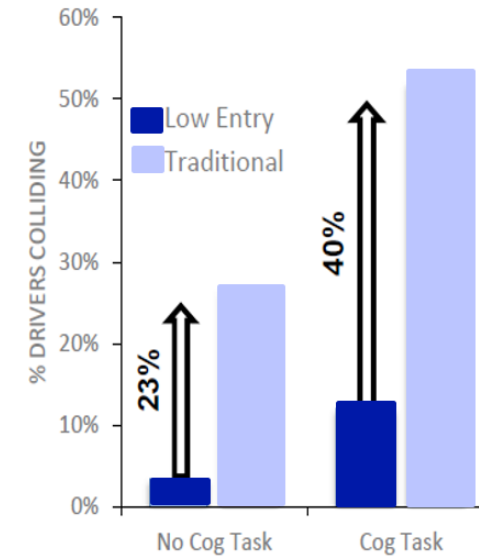

---

# Direct Vision Standard project (DVS)

The following content shows the approach that has been accepted by the manufacturers and other stakeholders during expert panel meetings

Multiple iterations of a number of standard design variables have been explored in order to get to this point

## Engagement with stakeholders

- Visit to Volvo/Renault development team in Gothenburg, Sweden
- Visit to Daimler/Mercedes development team in Stuttgart, Germany
- DAF development team visited the LDS
- LDS visited Dennis Eagle in Warwick
- DAF design team met with LDS and TfL reps in Loughborough
- IVECO meeting with LDS and TfL reps in London
- LDS visit to Scania, Milton Keynes
  
- **Expert working group (6 Meetings)** including all major manufacturers has met frequently to discuss progress and review methodology
  
- Numerous points of contact with UK reps for manufacturers to access CAD data and arrange legal agreements to allow the use of the data by Loughborough University
- **We have developed an excellent relationship with the manufacturers** which has supported our understanding of the technical issues and the provided valuable data for use in the project

---

Accident data review to define the areas of greatest risk

## DVS Standard: Reviewing the standard definition – Area of greatest risk

---

- The analysis of the UK accident database (**STATS 19**) for accidents between **Vulnerable road users** and **HGVs** above 7.5 tonnes has been performed
- This analysis was performed for all accidents between 2010 and 2015.
- Nationally this involves **2443 accidents**
- Each accident is **categorised** and recorded by a **police officer** using the STATS 19 accident recording form which is used when someone has been **injured or killed** on the highway
- There are numerous accident categories including data on **accident causation** which had to specially requested by the accident data analyst
- The following slides contain a summary of the accident data analysis



## DVS Standard: Reviewing the standard definition – Area of greatest risk

---

- The accident database that we have in the UK is widely regarded as being the most detailed in Europe
- The data contains a wide range of fields which can be used to explore specific issues
- For this project we have used the following fields;
  - ***Accident causation data (e.g. Blind spot, did not look properly etc. ) extra layer of data that must be requesting from DfT***
  - The severity of the accident (Fatal, serious or slight)
  - The vehicles and other people involved (e.g. HGVs above 7.5 tonnes, pedestrian, cyclist)
  - The Police force which has captured the data which allows us to compare the data in London and nationally
  - First point of contact between the vulnerable road user and the vehicle
  - Category of vehicle (e.g. rigid or articulated)
  - Vehicle manoeuvre being performed when the accident occurred (e.g. turning left, going straight on)
  - Junction type
  - Vehicle make and year of first registration
  - Speed limit on the road where the accident occurred
  - Lighting and weather conditions
  - Age of the casualty

## DVS Standard: National accident data for all HGV/cyclist accidents (2010-2015)

- 93 fatal (8%) – 336 serious (27%) – 773 – slight (64)%
  - Compared to all accidents in STATS 19 where in 2015
  - 1732 fatal (1%) – 22137 Serious (12%) – 162340 slight (87%)
- 882 cases were allocated to the categories of ‘failed to look properly’ or ‘vehicle blind spot’
- National data 85% of accidents occurred in daylight and 87% occurred in fine weather
- National data, first point of impact = 32% to the front, 32% to nearside and 29% to the offside (12 % to the rear not relevant to direct vision)
- 70% of accidents occurred on roads with a speed limit of 30mph or lower
- 301 out of 2404 took place in London (12.5%)

Caustion data for the top 95% of accidents with cyclists and HGVs above 7.5 tonnes (2010 – 2015)	
No. of accidents	Caustion category
<b>723</b>	<b>Failed to look properly</b>
357	Failed to judge other person's path or speed
321	Passing too close to cyclist horse rider or pedestrian
257	Poor turn or manoeuvre
219	Careless reckless or in a hurry
<b>159</b>	<b>Vehicle blind spot</b>
77	Loss of control
58	Cyclist entering road from pavement
39	Cyclist wearing dark clothing at night
36	Following too close
34	Other – Please specify below
33	Swerved
28	Road layout (eg. Bend hill narrow carriageway)
27	Junction restart (moving off at junction)
26	Vehicle door opened or closed negligently
24	Travelling too fast for conditions
23	Not displaying lights at night or in poor visibility
22	Failed to signal or misleading signal
21	Dazzling sun
19	Disobeyed 'Give Way' or 'Stop' sign or markings
18	Impaired by alcohol
17	Sudden braking
16	Stationary or parked vehicle(s)
16	Slippery road (due to weather)
16	Disobeyed automatic traffic signal
15	Nervous uncertain or panic
15	Aggressive driving
12	Rain sleet snow or fog
11	Vehicle travelling along pavement
10	Junction overshoot
10	Learner or inexperienced driver/rider
10	Poor or defective road surface
10	Fatigue

# DVS Standard: Accident data for all HGV/ pedestrian accidents

- 230 out of 1241 took place in London (19%)
- **226 fatal (18%) – 362 serious (29%) – 653 – slight (53)%**
  - Compared to all accidents in STATS 19 where in 2015
    - **1732 fatal (1%) – 22137 Serious (12%) – 162340 slight (87%)**
- 399 cases were allocated to the categories of ‘failed to look properly’ or ‘vehicle blind spot’
- National data 81% of accidents occurred in daylight and 87% occurred in fine weather
- National data, first point of impact = 45% to the front, 34% to nearside and 10% to the offside (10% to the rear not relevant for direct vision)

National causation data for the top 90% of accidents with pedestrians and HGVs above 7.5 tonnes (2010 – 2015)	
<b>No. of accidents</b>	<b>Causation category</b>
<b>284</b>	<b>Failed to look properly</b>
<b>125</b>	<b>Vehicle blind spot</b>
105	Poor turn or manoeuvre
101	Passing too close to cyclist
80	Careless
50	Failed to judge other person’s path or speed
39	Other – Please specify below
31	Overloaded or poorly loaded vehicle or trailer
26	Stationary or parked vehicle(s)
23	Road layout (eg. bend)
12	Temporary road layout (eg. contraflow)
12	Vehicle travelling along pavement
11	Disobeyed pedestrian crossing facility
11	Junction restart (moving off at junction)
10	Travelling too fast for conditions

London Only data	
<b>47</b>	<b>Vehicle blind spot</b>
<b>21</b>	<b>Failed to look properly</b>
4	Junction restart (moving off at junction)
4	Passing too close to cyclist horse rider or pedestrian
3	Poor turn or manoeuvre
3	Careless reckless or in a hurry
2	Temporary road layout (eg. contraflow)
1	Stationary or parked vehicle(s)
1	Illegal turn or direction of travel

# DVS Standard: Specific data on accidents where *blind spot* is the cause (HGV-Ped)

- 47 out of 125 took place in London (38%)
- **44 fatal (35%)** – 29 serious (23%) – 52 – slight (41)%
  - Compared to all accidents in STATS 19 where in 2015
    - **1732 fatal (1%)** – 22137 Serious (12%) – 162340 slight (87%)
- 94% of accidents occurred in daylight and 93% occurred in fine weather
- 60% of accidents occurred at some form of pedestrian crossing
- National data, first point of impact = 46% to the front, 29% to nearside and 8% to the offside (18% to the rear not relevant for direct vision)

National causation data for the top 90% of accidents with pedestrians and HGVs above 7.5 tonnes (2010 – 2015)	
<b>No. of accidents</b>	<b>Causation category</b>
<b>284</b>	<b>Failed to look properly</b>
<b>125</b>	<b>Vehicle blind spot</b>
105	Poor turn or manoeuvre
101	Passing too close to cyclist
80	Careless
50	Failed to judge other person's path or speed
39	Other – Please specify below
31	Overloaded or poorly loaded vehicle or trailer
26	Stationary or parked vehicle(s)
23	Road layout (eg. bend)
12	Temporary road layout (eg. contraflow)
12	Vehicle travelling along pavement
11	Disobeyed pedestrian crossing facility
11	Junction restart (moving off at junction)
10	Travelling too fast for conditions

London Only data	
<b>47</b>	<b>Vehicle blind spot</b>
<b>21</b>	<b>Failed to look properly</b>
4	Junction restart (moving off at junction)
4	Passing too close to cyclist horse rider or pedestrian
3	Poor turn or manoeuvre
3	Careless reckless or in a hurry
2	Temporary road layout (eg. contraflow)
1	Stationary or parked vehicle(s)
1	Illegal turn or direction of travel

# DVS Standard: Reviewing the standard definition – STATS 19

- Accidents between pedestrians and HGVs associated with blind spots show a spike above the age of 65 (See bottom graph)
- This is very different to the distribution of age for accidents for all accidents between pedestrians and HGVs (See top graph)
- **Why are accidents associated with blind spots so biased towards elderly pedestrians?**
- When an accident occurs pedestrians are not seen, the older pedestrians are unable to get out of the way when a truck pulls off?

Number pedestrian casualties by age 2010-2015  
(all HGV-Ped Accidents)

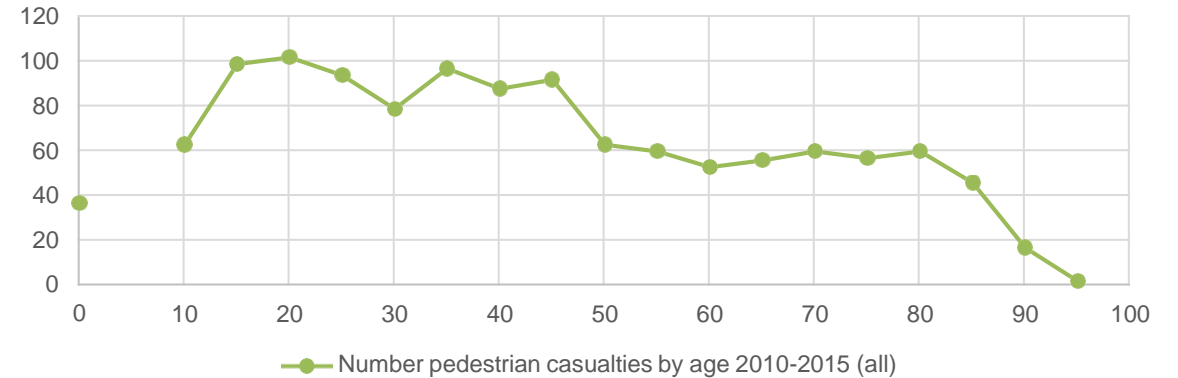

Number pedestrian casualties by age 2010-2015  
(Blindspot HGV-Ped Accidents)



# DVS Standard: Reviewing the standard definition – STATS 19

- There is no such difference in the age of casualties between the whole sample of **HGV-Cyclist** and specific blind spot accidents for HGV-Cyclist
- See graphs

Number pedestrian casualties by age 2010-2015  
(**all** HGV-Cycle Accidents)

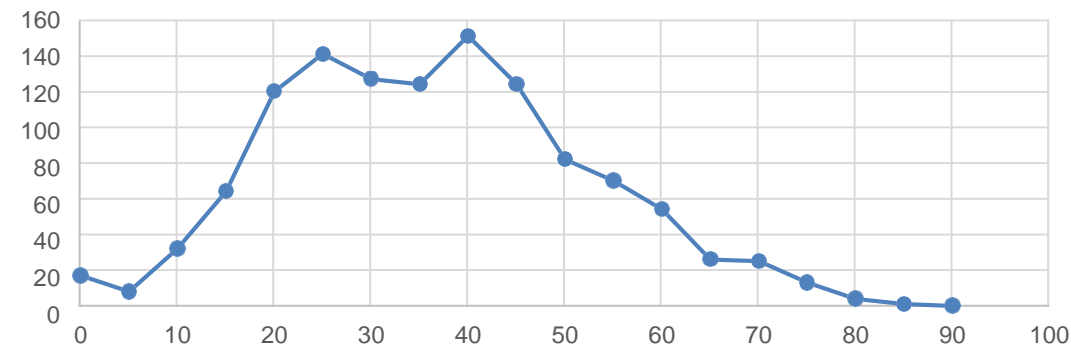

Number pedestrian casualties by age 2010-2015  
(**Blindspot** HGV- cyclist Accidents)

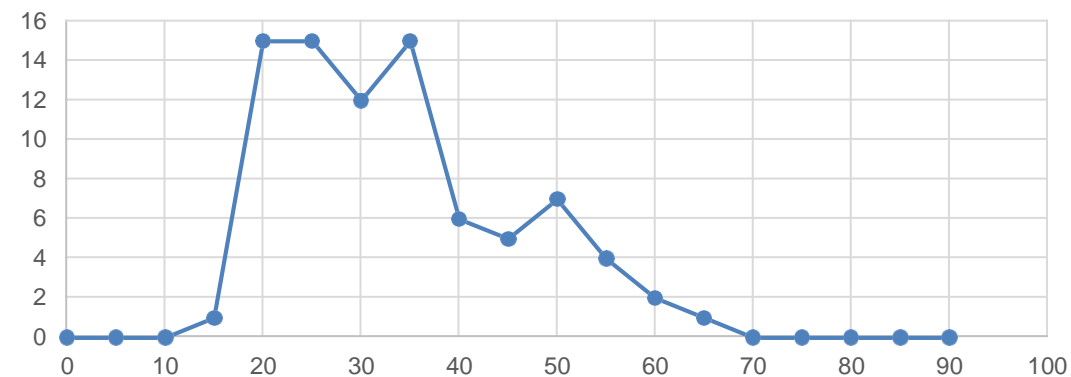

Cyclist and pedestrian casualties by age National 2010-2015 where accident is attributed to blind spot

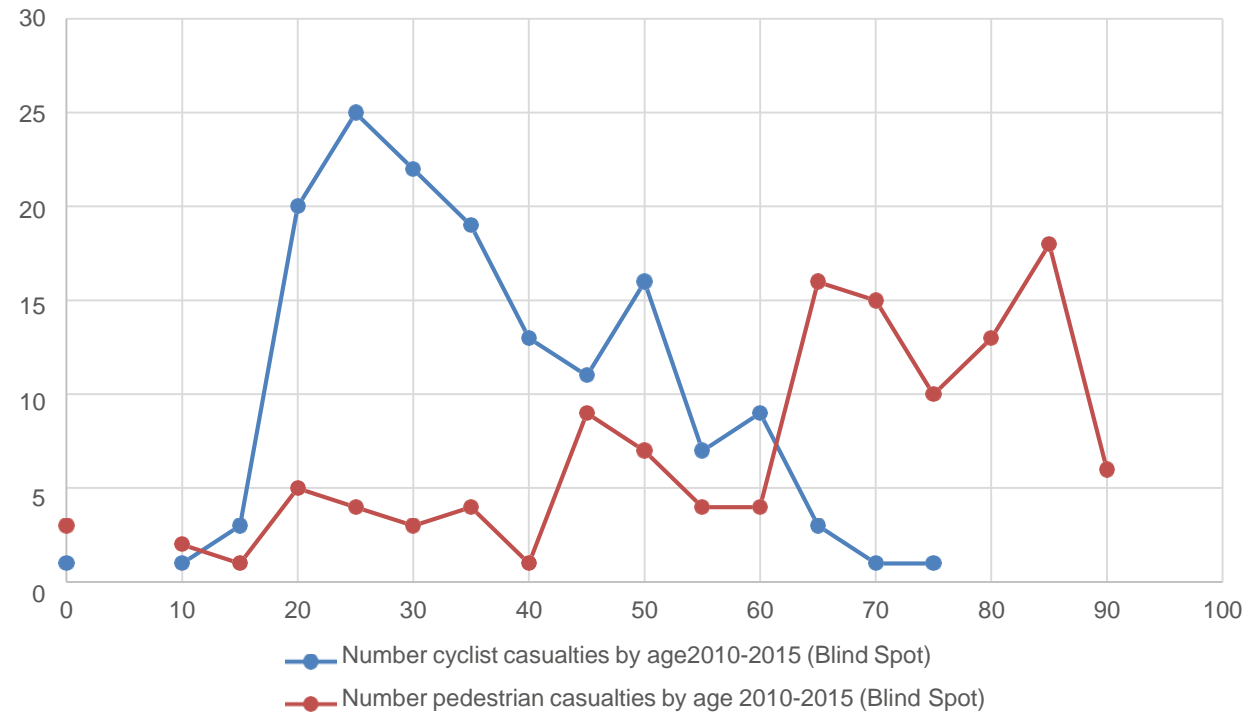

## Summary of issues identified from accident data review

---

- Accidents between **HGVs and VRUs** are more likely to result in **death or serious injury** when compared to the whole accident database
- An analysis of **accidents in London** highlighted that HGVs are **disproportionality associated** with accidents with VRUs based upon volume of traffic of HGVs and other vehicles
- **Older pedestrian VRUs** are more likely to be involved in accidents with HGVs where **death or serious injury** is the result (where blind spot is the causal factor)



# DVS Standard: Defining the candidate weighting scheme – ‘Area of greatest risk’

- The accident data provided the option to weight the importance of vision around the truck by;
  - Using the data on the first point of contact between a HGV and vulnerable road user during an accident
  - Or
  - Using the data which tells us the manoeuvre that the vehicle was making during the accident
- The image to right shows the importance weighting based upon first point of contact for all accidents where “blind spot” was listed as a contributory factor

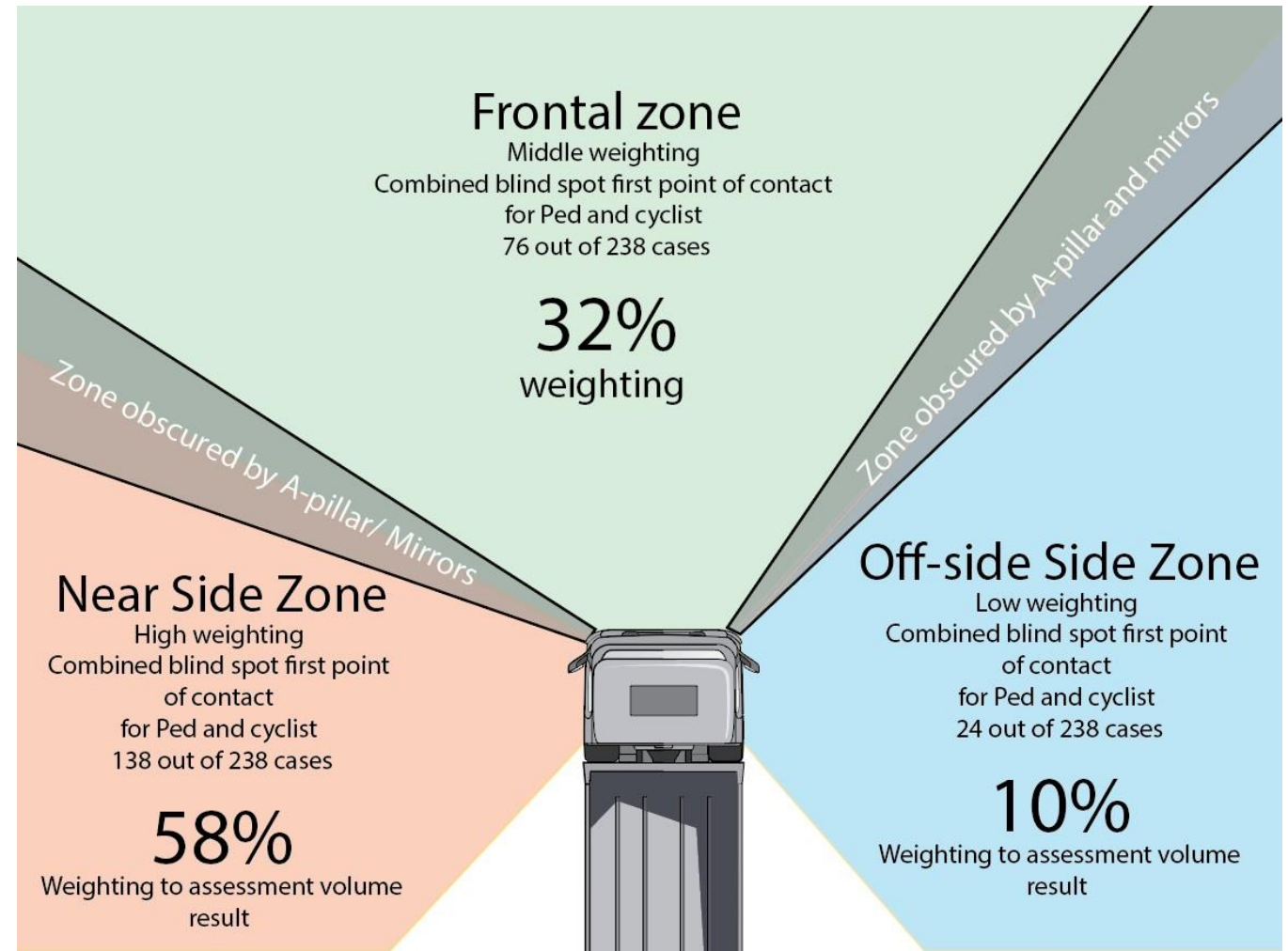

How does the London DVS work?

## The starting point for the project

---

- A simple premise
  - Define a volume of space around the truck cab that should be visible to the driver – this is known as the **assessment volume**
- Project the volume of space that can be seen by a driver using a repeatable method for all trucks
- Intersect the two volumes to determine the proportion of the assessment volume that can be seen by the driver – this can be directly compared between vehicles

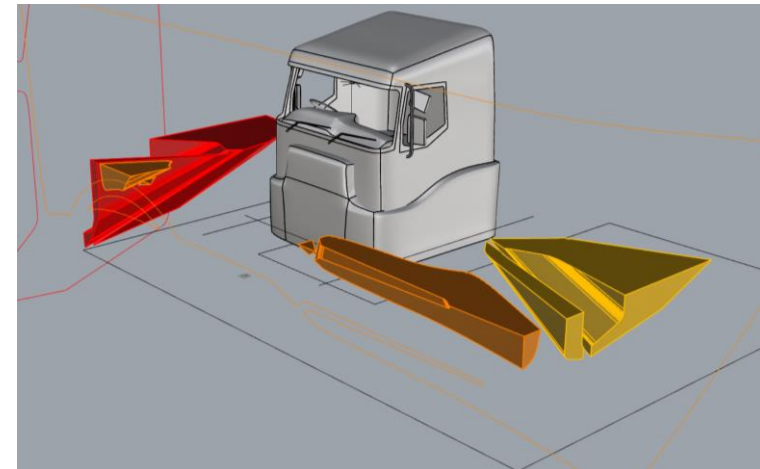
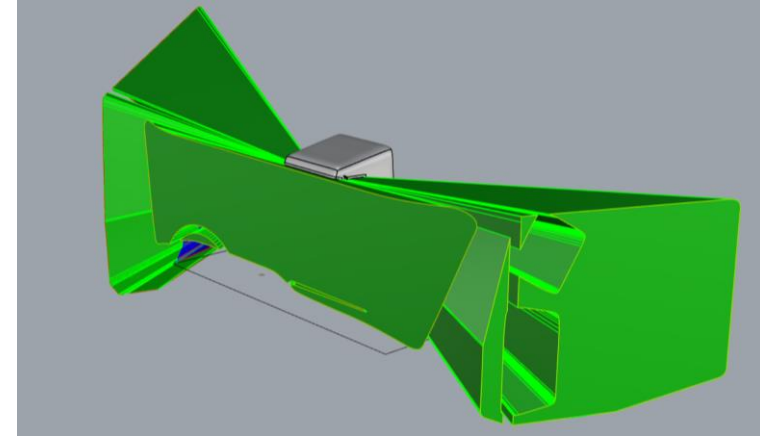
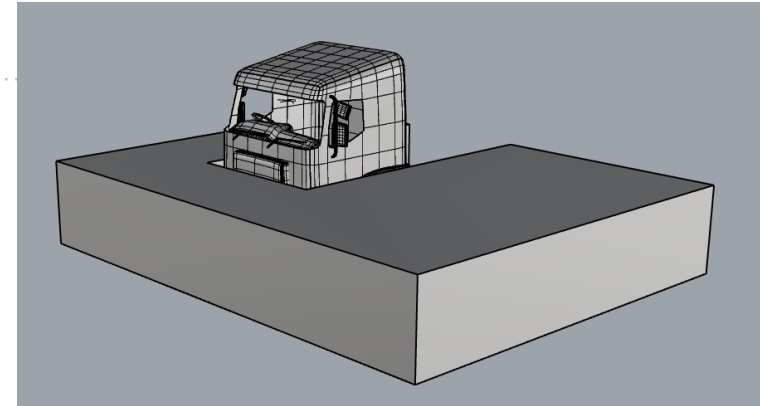

## Defining the size of the assessment volume

- Two main candidates (and a number of variations) of the 'Assessment Volume' have been tested with a sample of over 50 vehicles over the past 18 months
- Initially a very large volume was designed and tested
- This proved the principle with a large sample of trucks but did not differentiate between the vehicles well enough in terms of the actual scores
- Therefore a version was created which reduced the volume size, matching the volume of space that should be visible in mirrors as per UNECE regulation 46

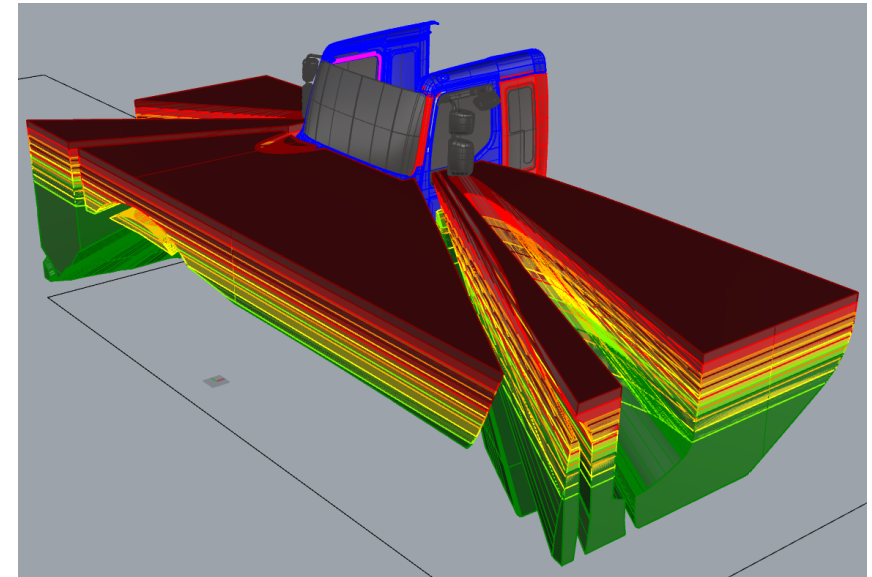
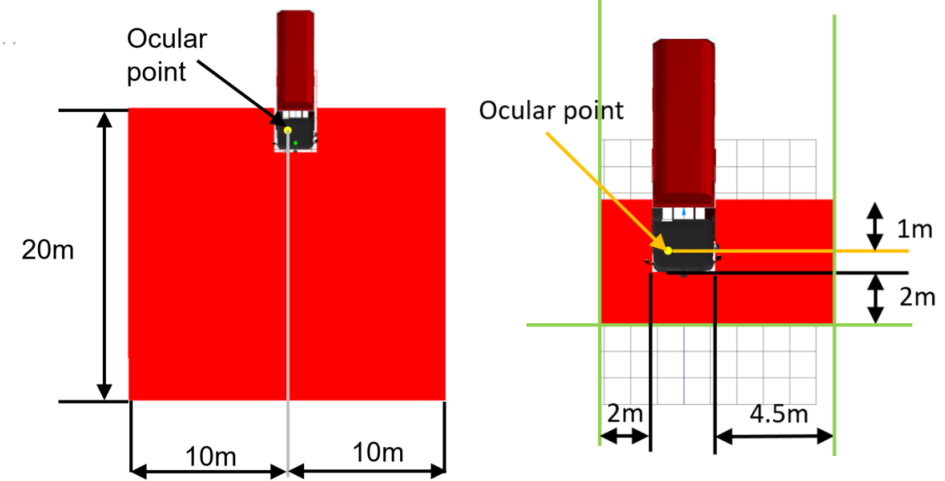

## Defining the assessment volume

- The **height of the assessment volume** has been modelled around body size for the **European population**
- The key premise here is that the volume covers the height range from the floor, to the shoulder height of the tallest European (99<sup>th</sup> percentile Dutch Male, only 1% of the Dutch population is taller)
- There is an assumption that the seeing the **head of shoulders** of a VRU is enough for a driver to recognise that VRU

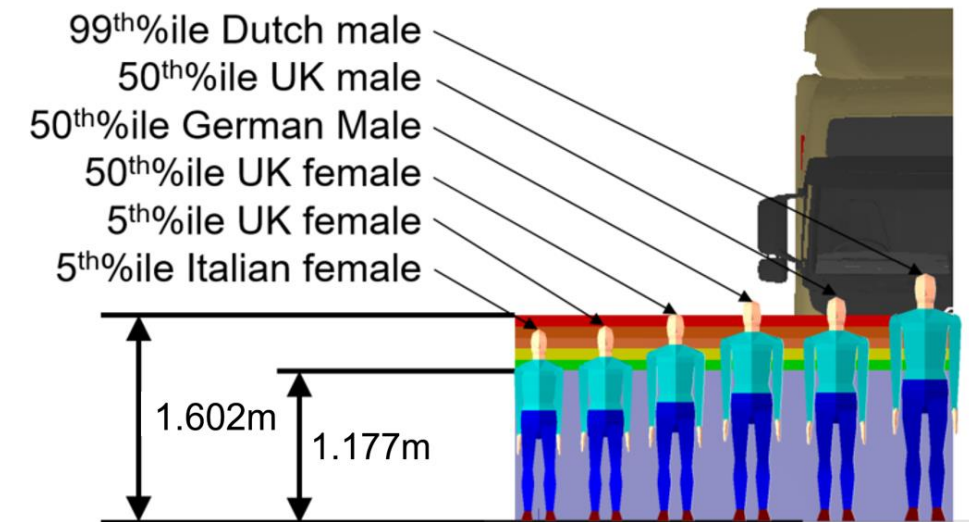
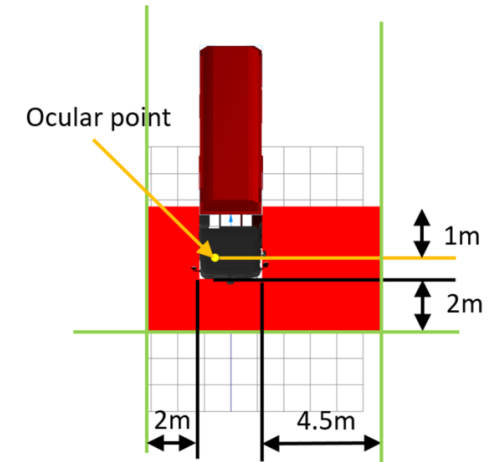

## Defining the assessment volume

- The selected version has been set to model the area around a vehicle that should be visible through the use of the **6 mirrors using** a standardised area defined in UNECE regulation 46
  - whilst also including an offside zone which accounts for 10% of accidents with VRUs
- The premise of this candidate is that any vehicle which does not allow direct vision of a defined VRU (5<sup>th</sup> percentile Italian female) outside of the mirror coverage zone is performing badly as people can fit in the blind spot between direct vision (through windows) and indirect vision (through mirrors) and not be visible to the truck driver
- This was set a minimum DVS requirement based upon a preliminary analysis of a sub sample which showed poor performance for some vehicles in this test

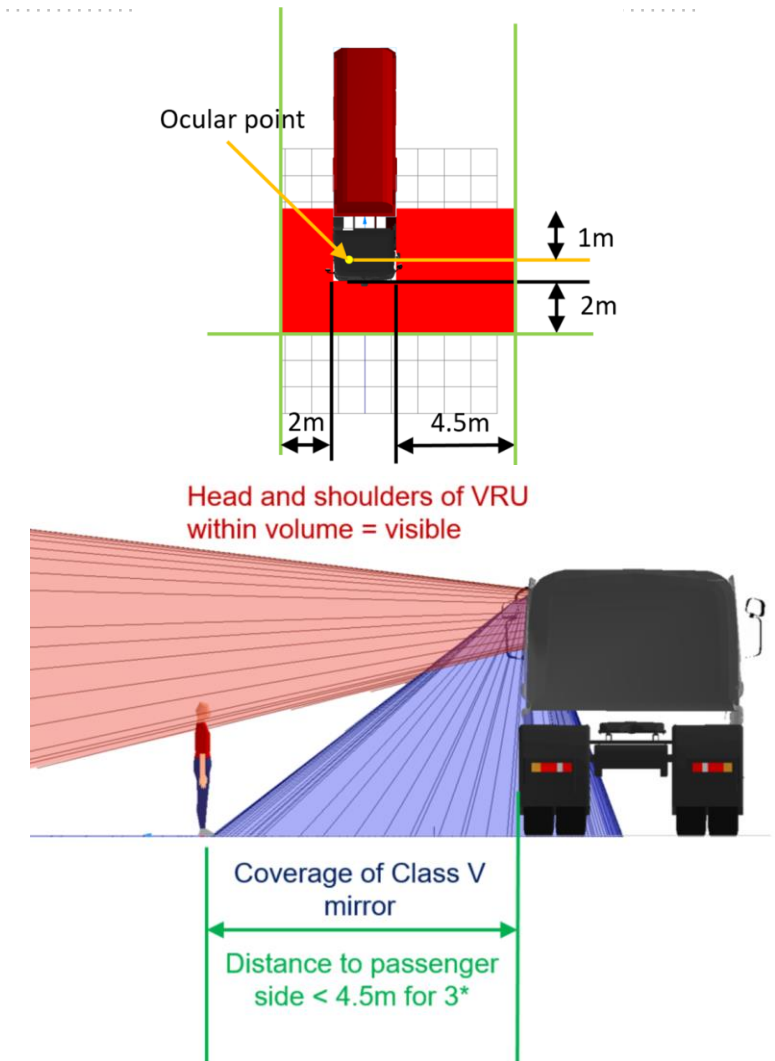

## Methodology

- CAD data is imported into the CAD system
- The extents of the cab are identified using the [UNECE regulation 46](#) definition for width and length and the surfaces to be included in their definition

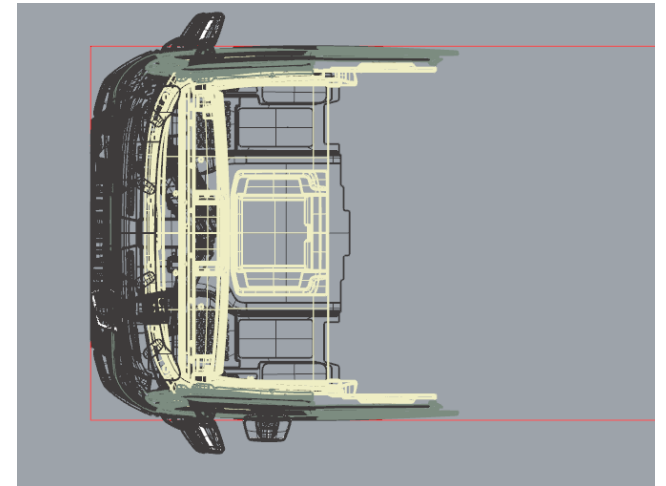

# Methodology

- The assessment volume is aligned to the truck sides and front

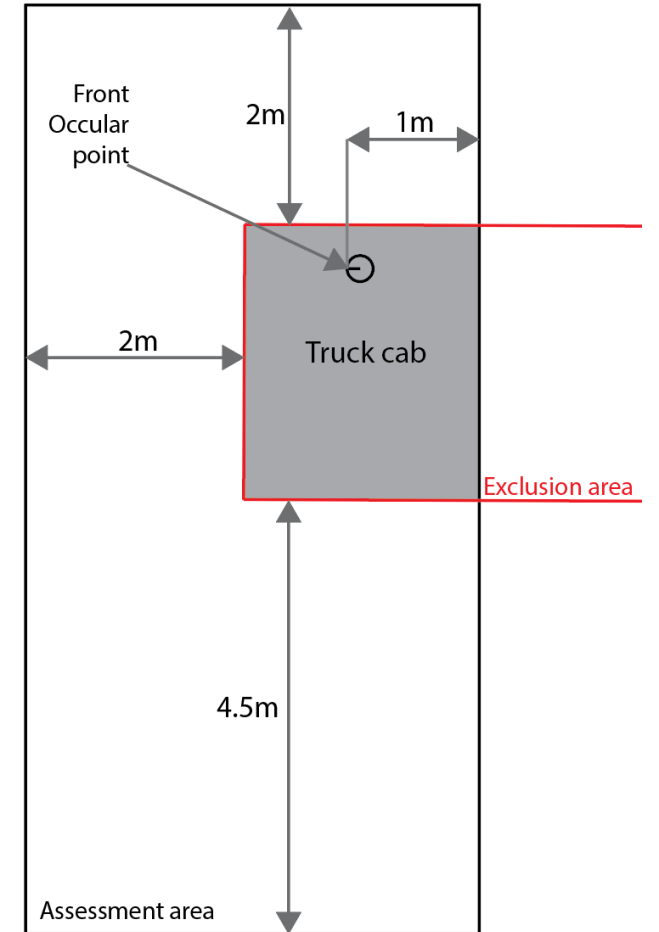
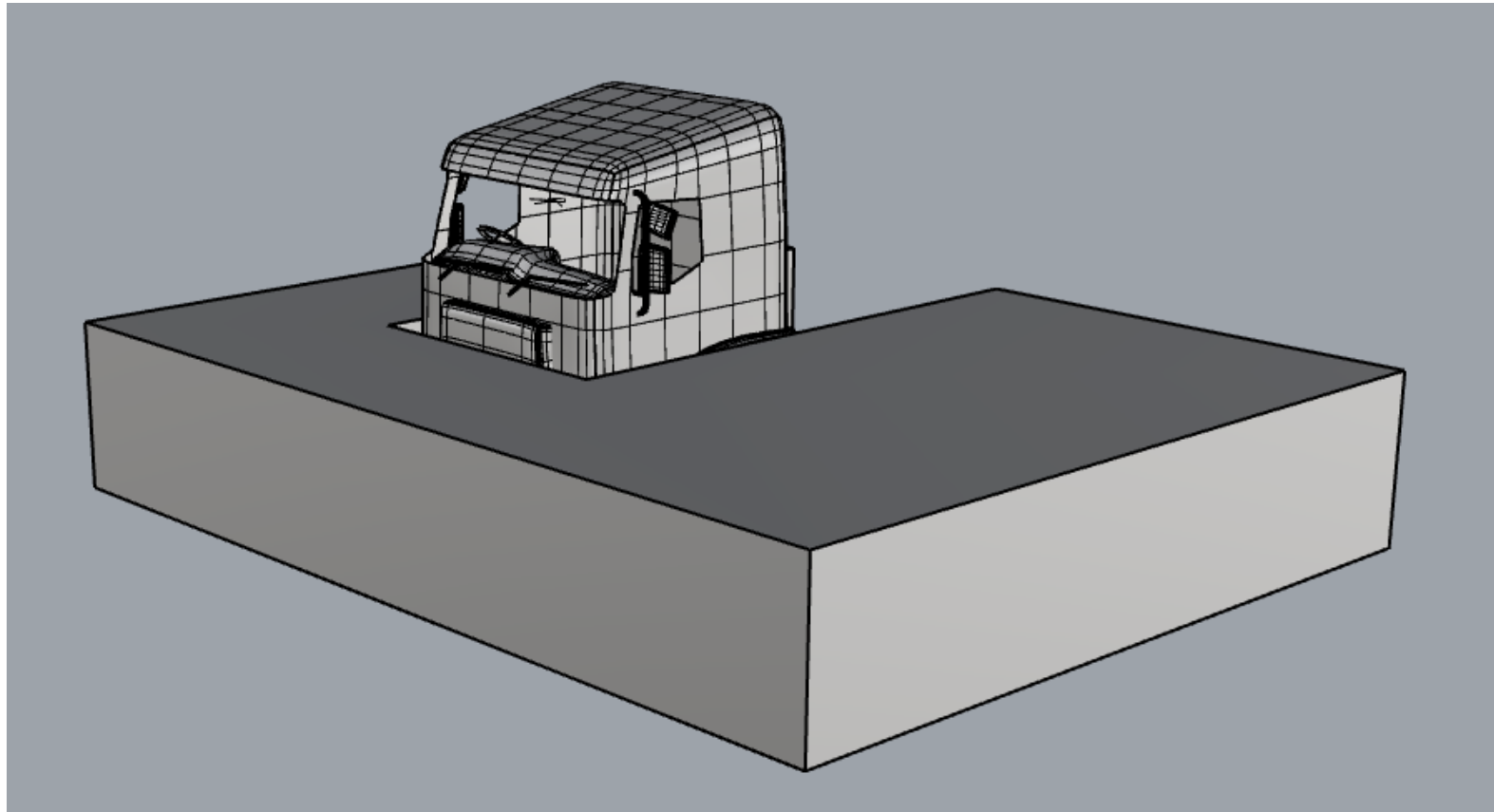



# Methodology

- The forward eye point is defined by an offset from the accelerator heel point (AHP)
- This eye point was defined with the agreement of manufacturers and is a standardised eye point which can be used with any vehicle
  - Multiple other options were considered including using standard hip point (SgRP) definitions and offsets for an eye point as defined in UNECE regulation 46, however these led to some manufacturers gaining an advantage when a full analysis of all trucks was performed due to variability in the use of the SgRP within the H-point envelope
- The eye point has been defined by taking into account the seat positions of all trucks (**common h-point location identified**), combined with an offset from the seat which replicates **average European eye height** for a truck driving posture
  - 50<sup>th</sup>ile male and female offsets identified for **UK, Germany, Holland, France, Italy, Sweden** and then this is averaged with a 90:10 male female split.

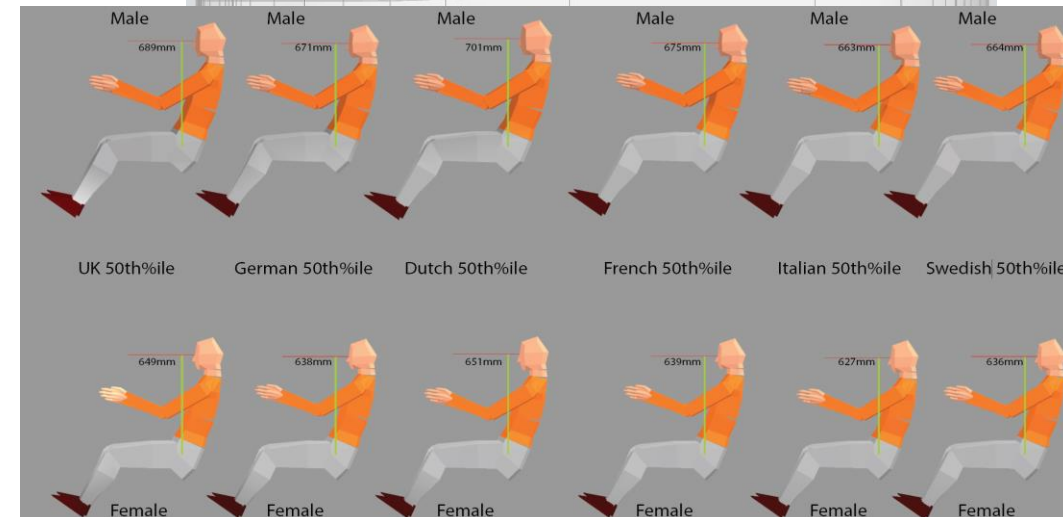
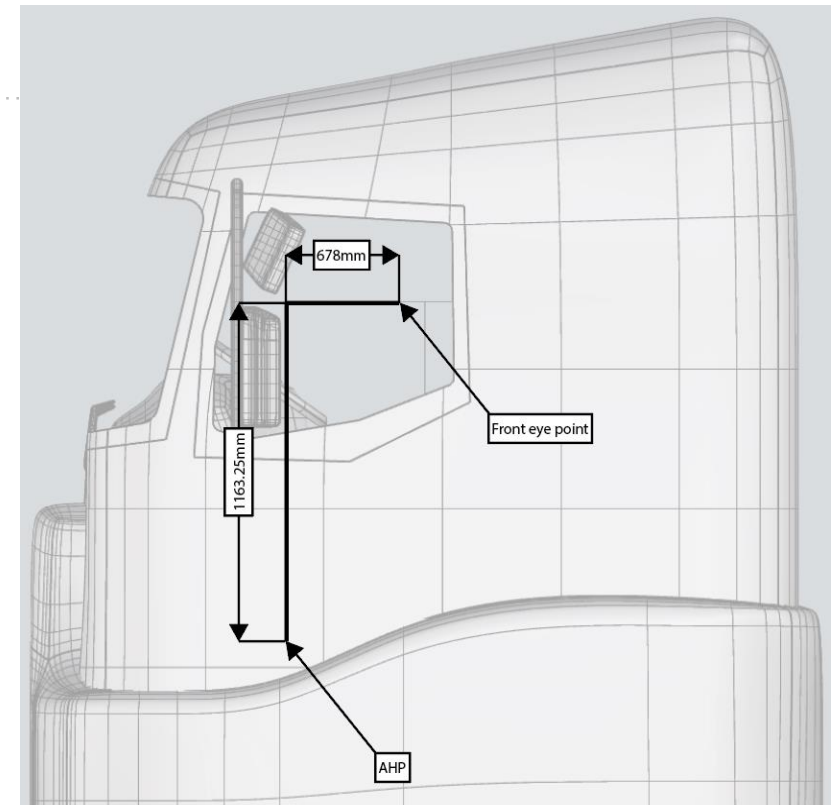

# Methodology

- The 'eye rig' is generated to simulate the view of virtual driver to the front, left and right of the cab using the premise defined by reg 125.

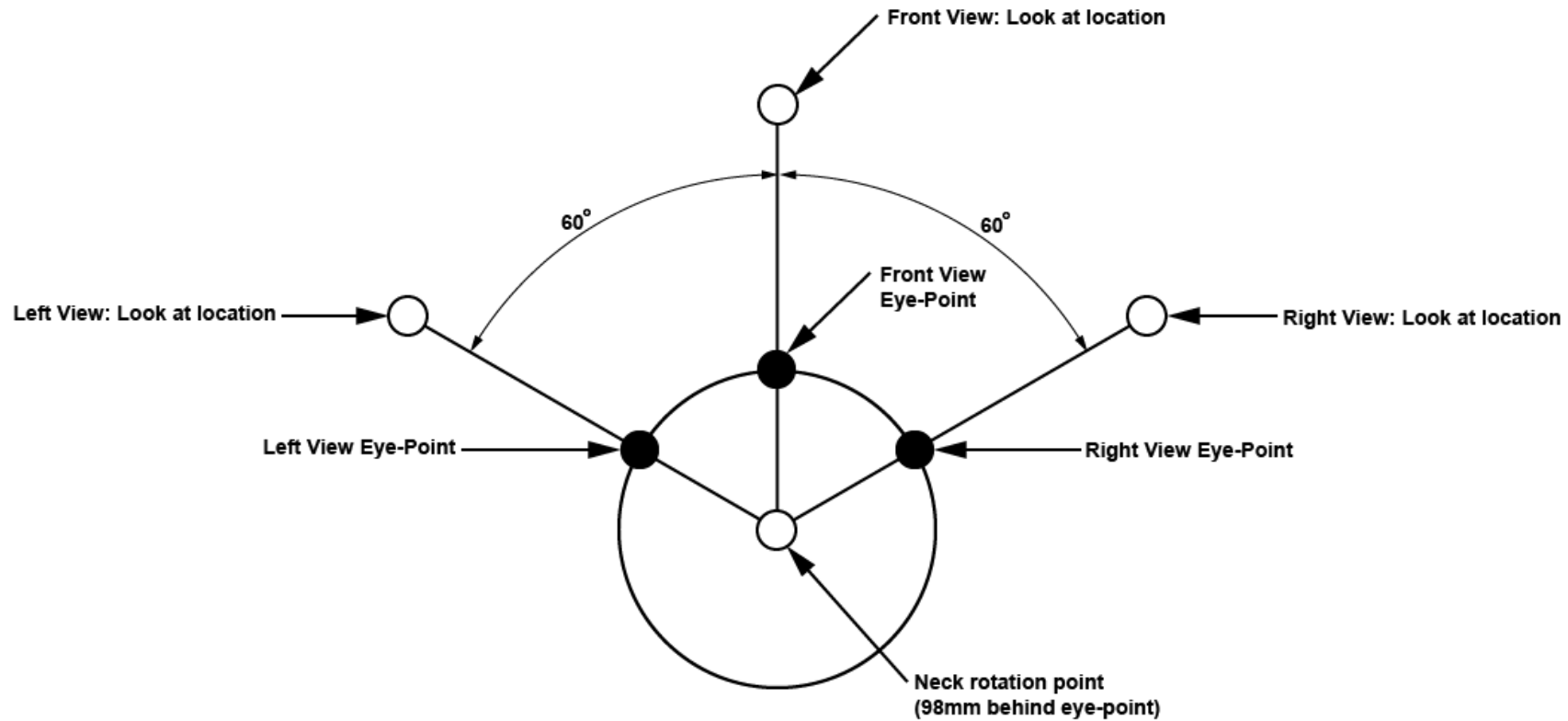

---

## The testing methodology

## Methodology

- The eye rig is used to define projection points for paths which enclose the visible areas of the front, left and right windows

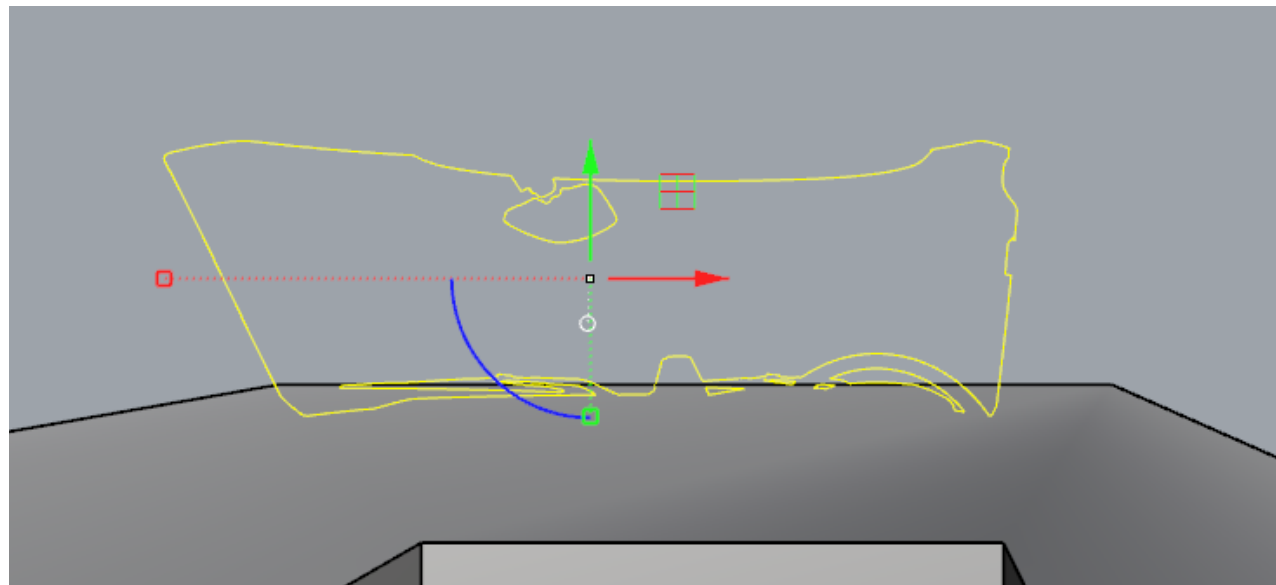
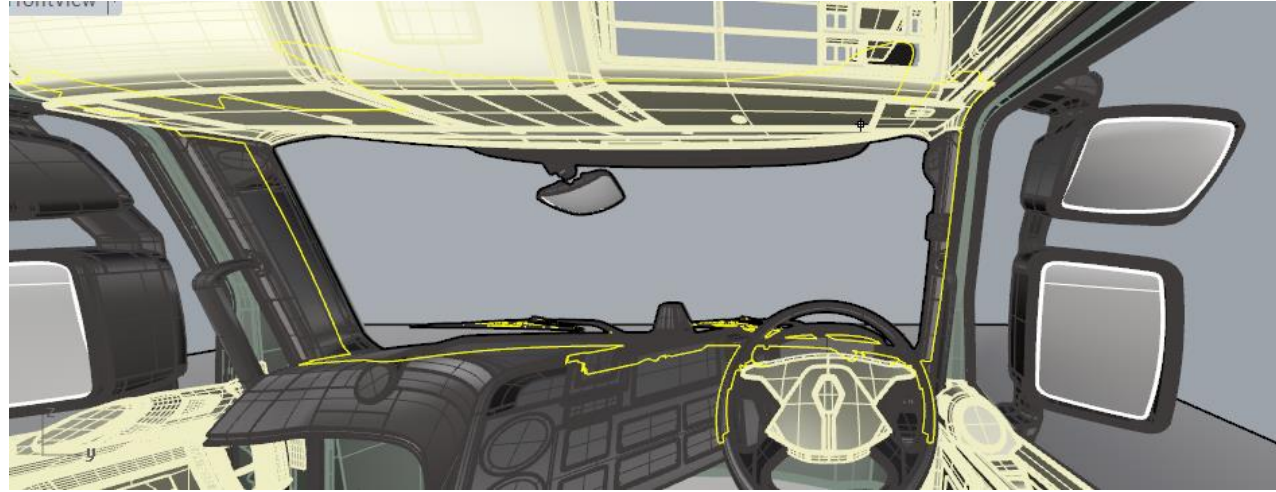

## Methodology

- The left, front and right views are projected separately to ensure that a-pillar design is account for
- Tests have been before using monocular and binocular eye points. Most manufacturers recommended the monocular eye point due to the difficulty associated with the processing of ambinoocular projections and this was validated by the LDS team
- However a further analysis was performed to define the differences between monocular and ambinoocular which showed small volumetric differences in the results

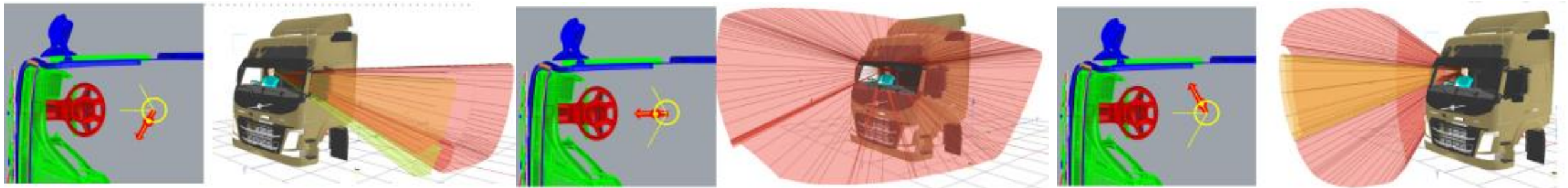

## Methodology

- These paths are extruded to show the volume of space visible to the virtual driver

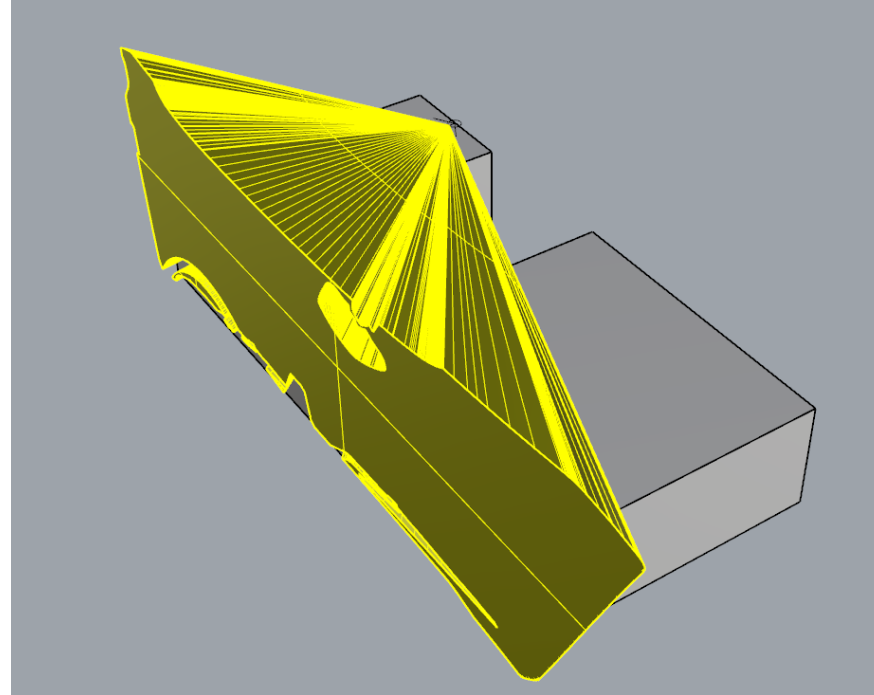

## Methodology

- These volumes are intersected to find the portion of the assessment volume that is visible to the virtual driver. These values can be compared between truck designs
- Front view only shown

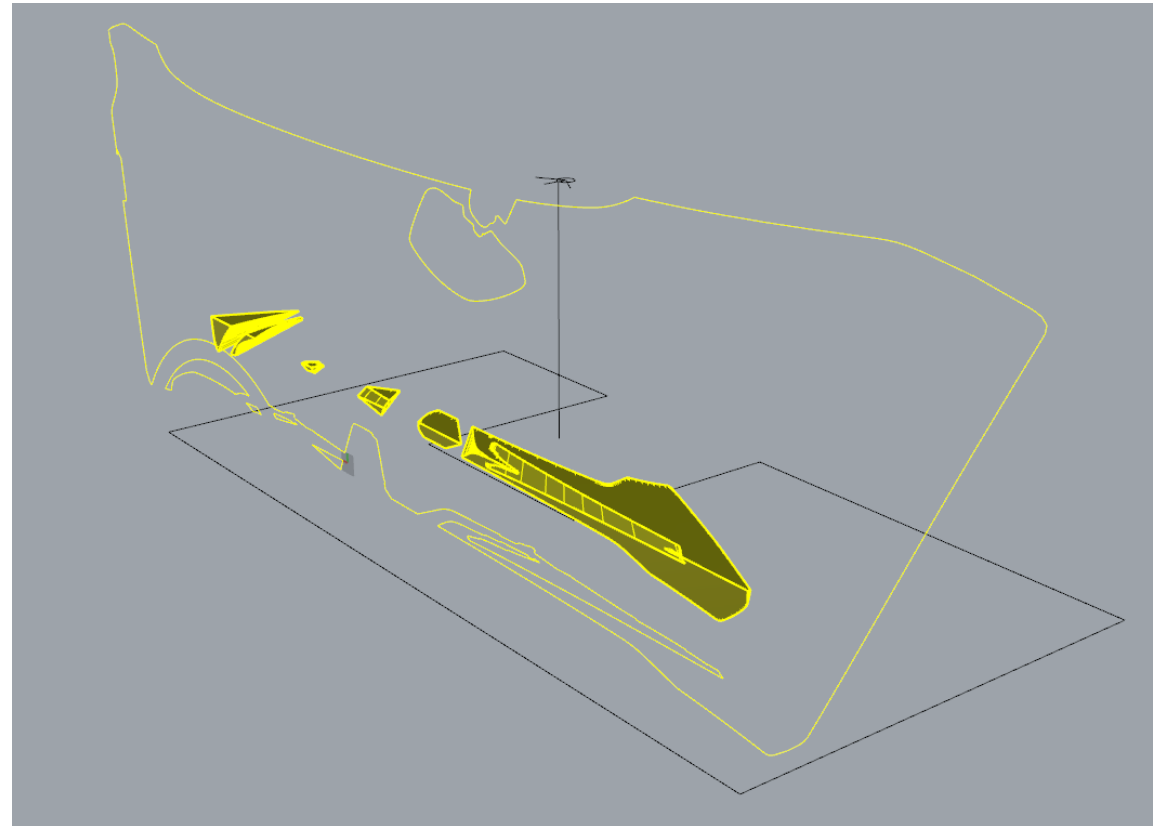

# Volumetric results (in performance order)

- With a set of volumes defined we needed a method by which we could assign certain volumes to certain performance bands or star ratings in the case of the TfL DVS
- The volumetric results in isolation are abstract and difficult to relate to the real world problem.
- Therefore the following slides show how we linked the volumetric results to the real world

Volumetric results for Candidate 1 Trimmed in order of performance (higher is better)

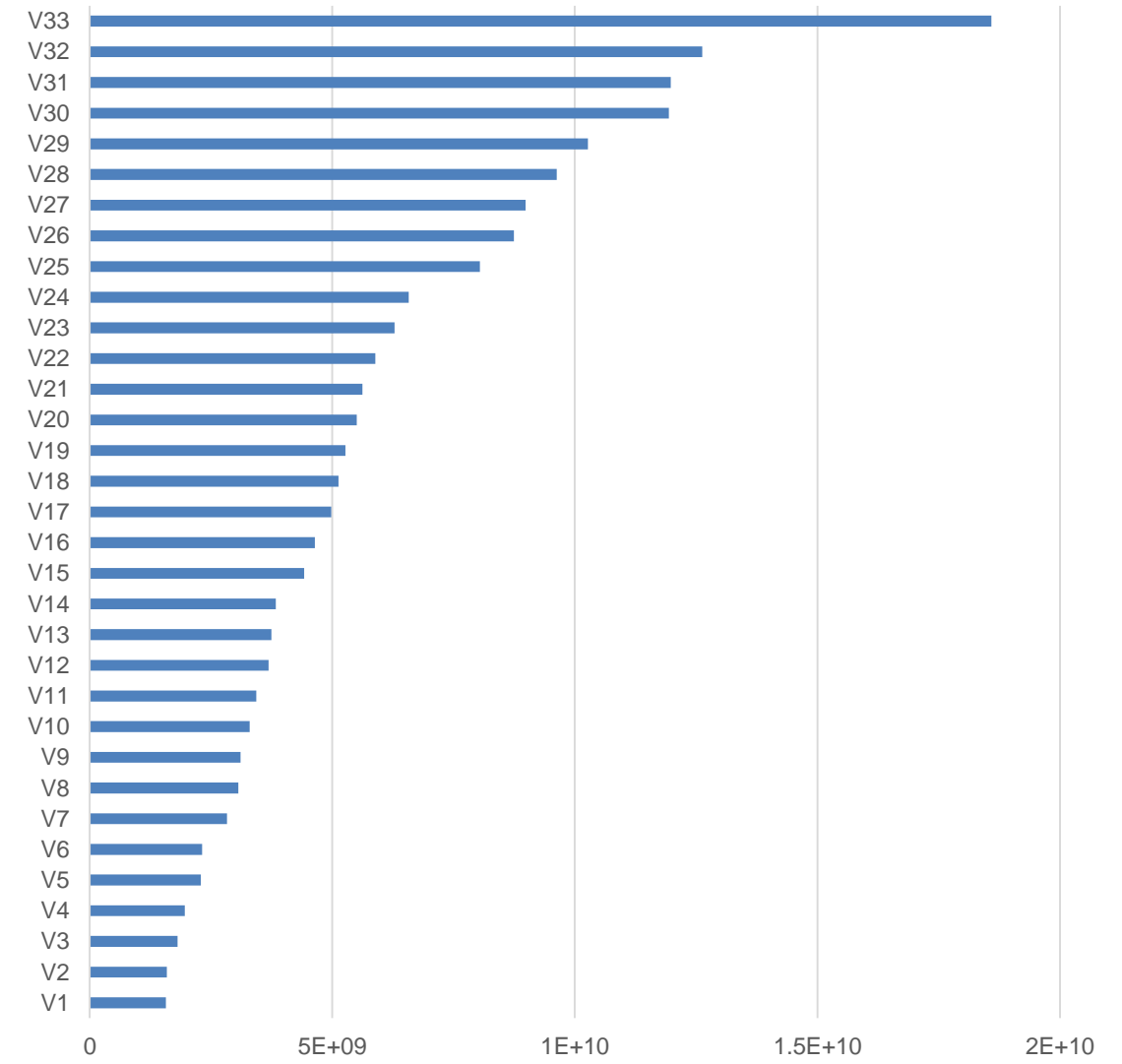



---

## Quantifying the volumetric results

# Quantifying the volumes against real world performance

- A number of VRU simulations were created and orientated around the vehicle
- The distance at which the head and shoulders of the VRU could be seen to the sides and front of the vehicle were calculated and correlated with the volumetric results

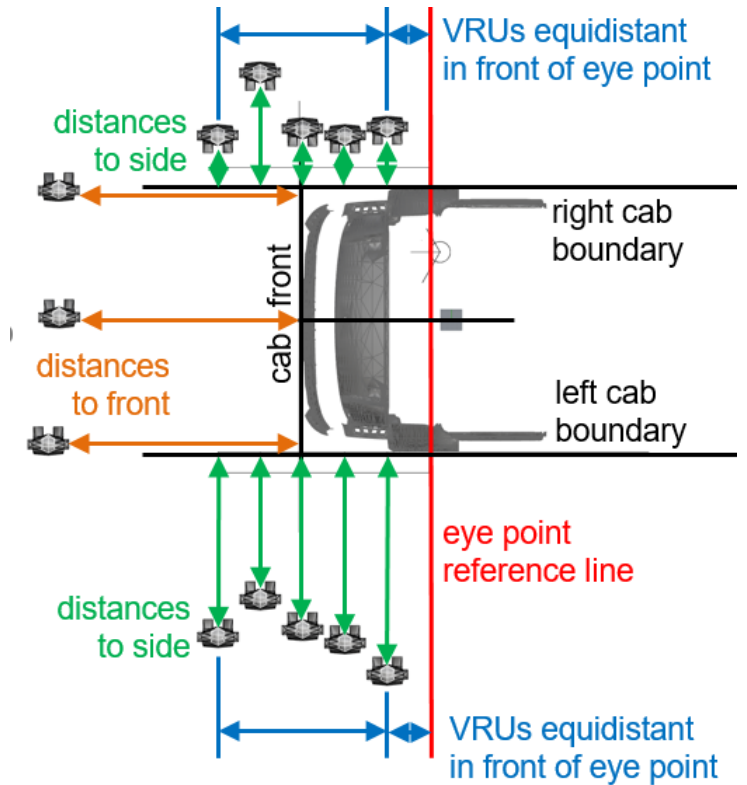
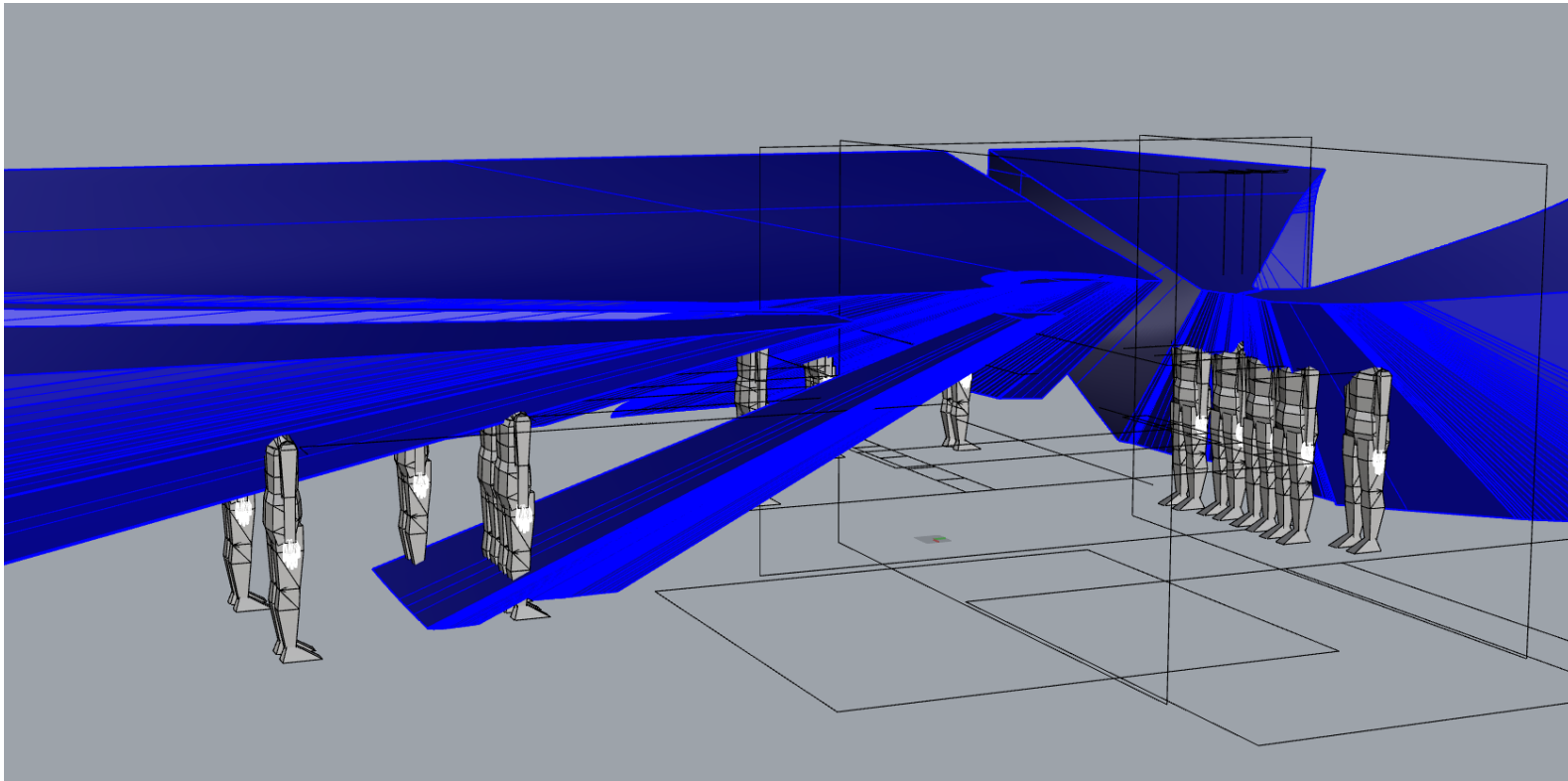

## Quantifying the volumes against real world performance

- We have opted to use the **5<sup>th</sup>ile Italian female** as the key VRU as this is **smallest population in Europe** based upon an analysis of anthropometric data
- This means that the full European population is covered by the standard (-5% of Italian females)
- **Therefore if the head and shoulders of the smallest European female (apart from 5% of Italian females) can be seen then in theory the whole adult population of Europe can be seen.**

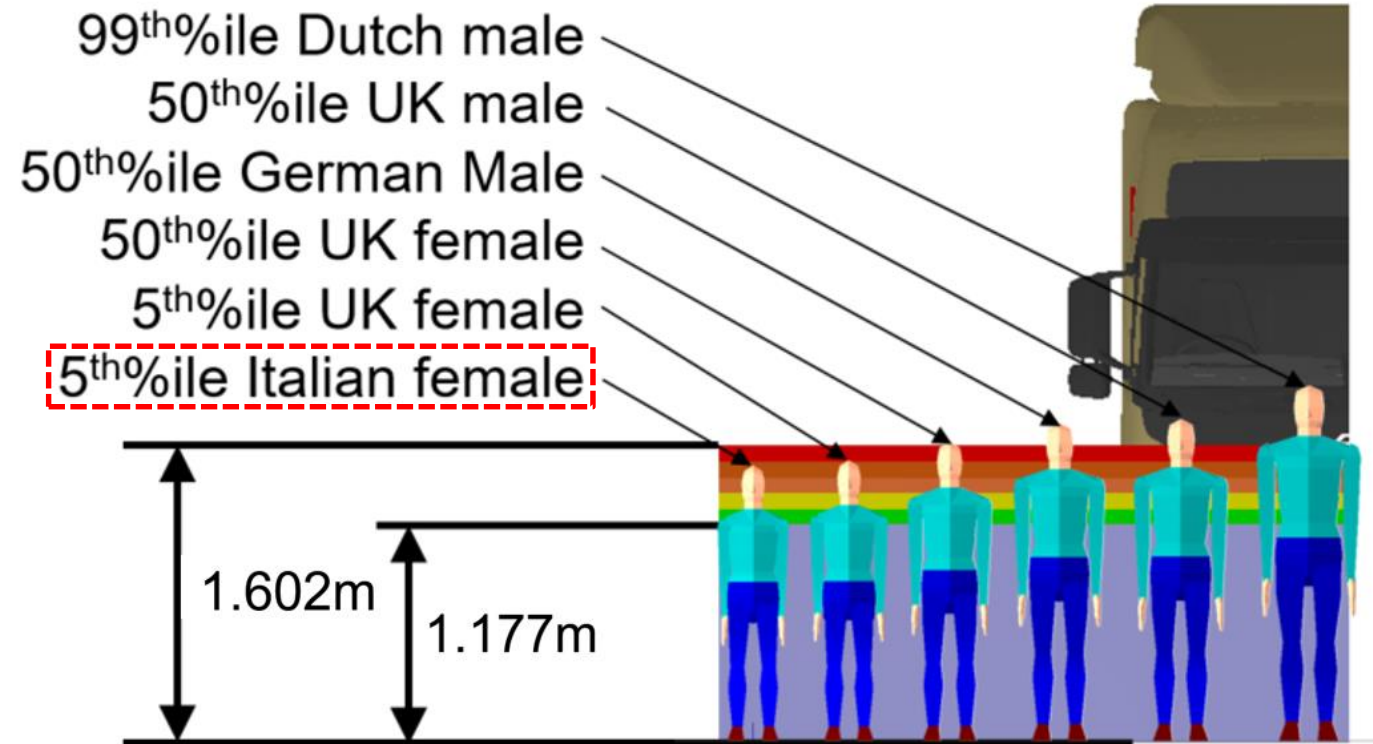

## Setting up the VRU simulations

- The boundaries of the cab are identified to the front, left and right
- 5 VRUs (**5<sup>th</sup> %ile Italian female pedestrian**) are positioned to left and right, and 3 VRUs to the front
- VRUs to the sides are positioned in relation to the driver's eye point in equal increments extending into mirror obscuration zones
- VRUs to the front are positioned on the centreline of the cab at to either side
- Distances from the shoulder line to the front / side of the cab are recorded
- Multiple versions of the VRU setup were analysed
- This version provided a high correlation with Volume scores (see later)

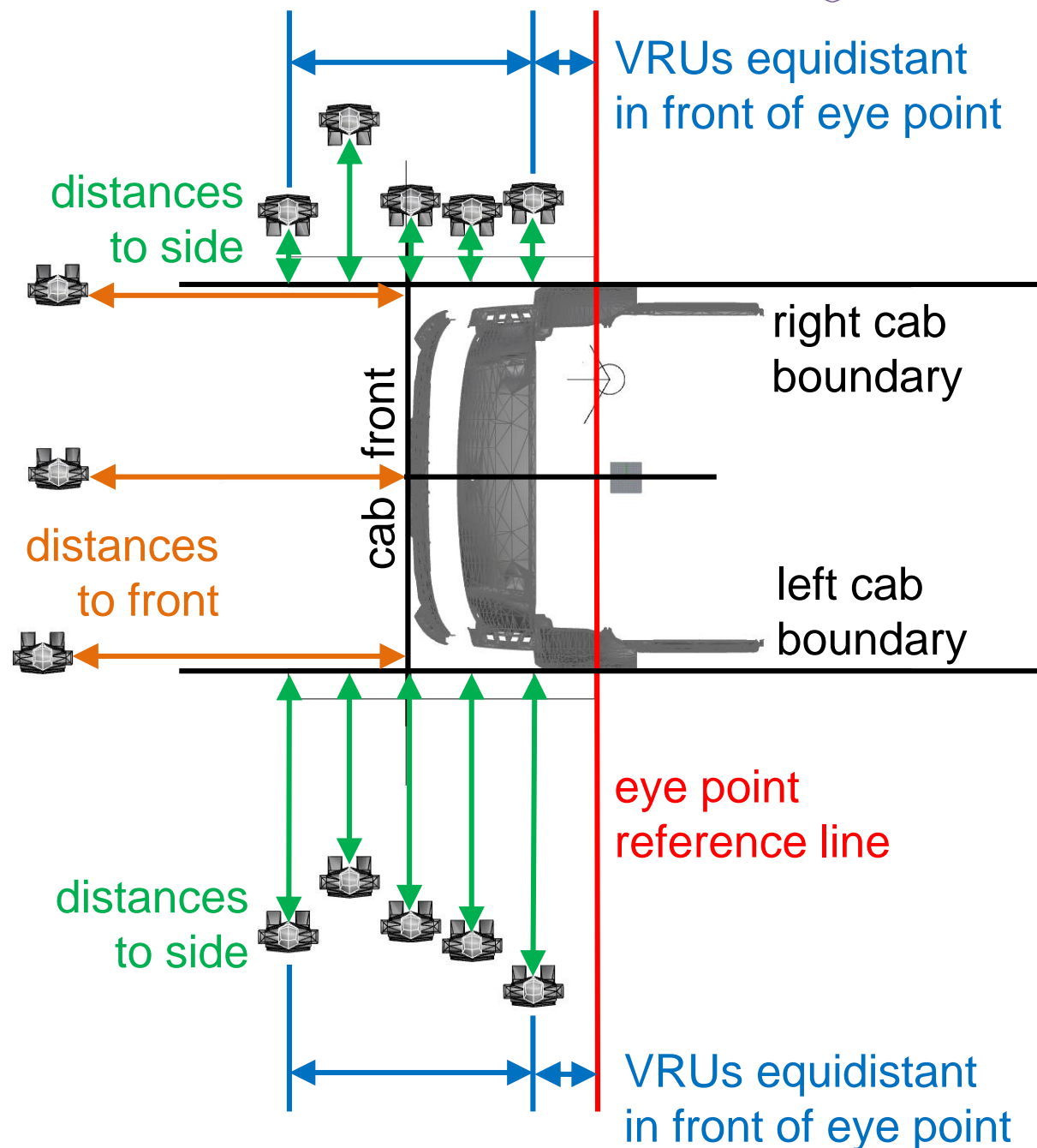

## Applied example

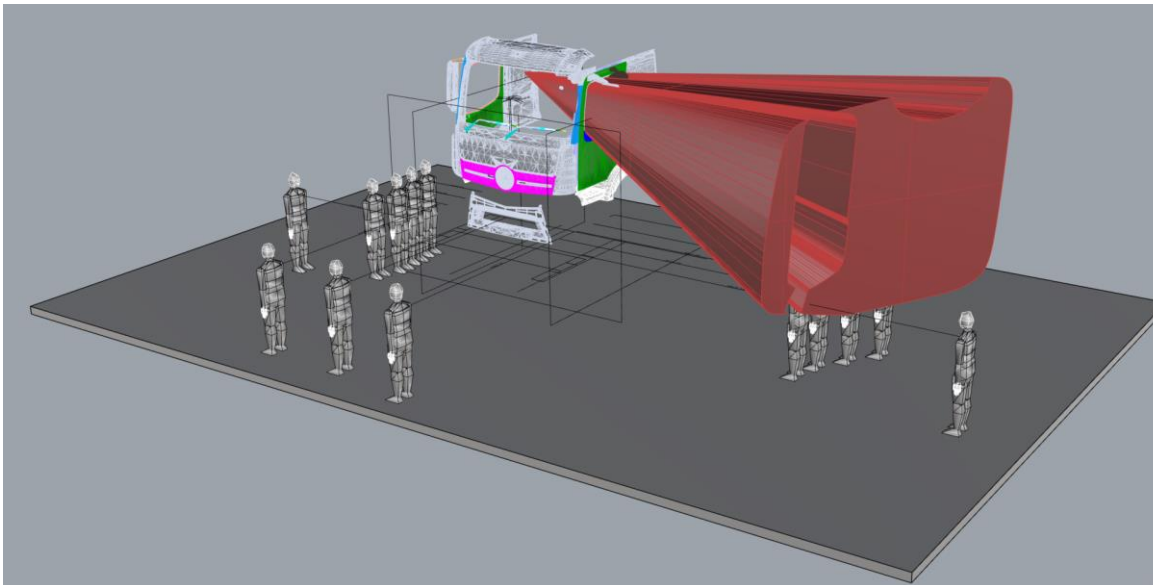
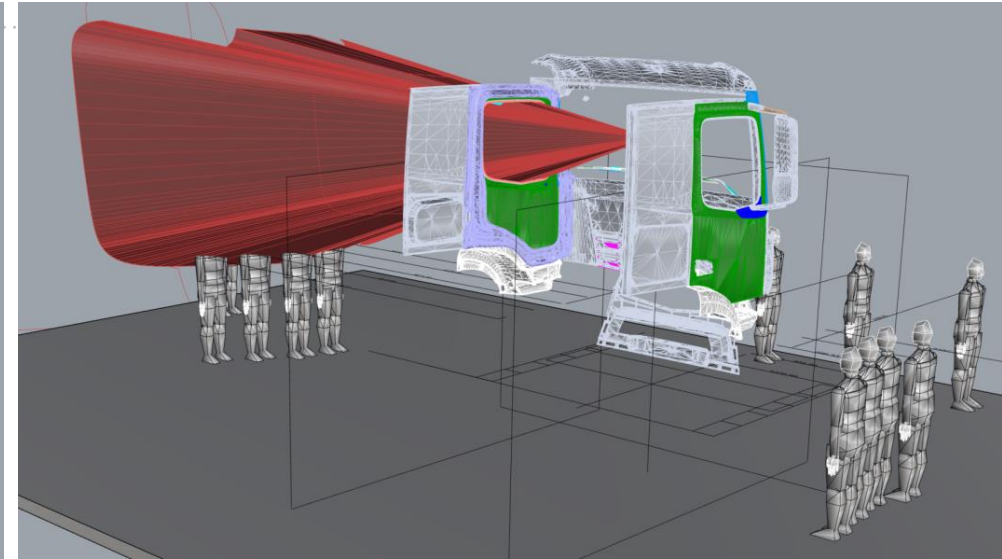
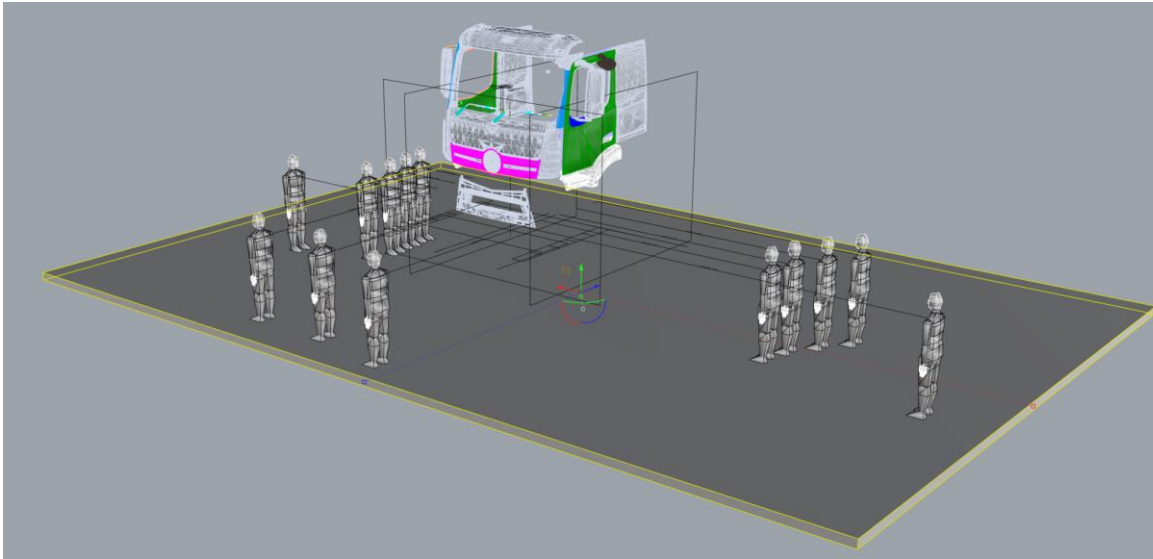

- Top Left – The VRUs are shown around the truck
- Bottom left- the visible volume through the left window is shown
- Top right – The head and shoulders of the VRU intersect with the visible volume at the locations shown and the distances of all VRUs from the side of the truck are measured

# Methodology

- In order to reach 1 star a vehicle must allow the average of the VRU distances to the front, left and right to be 2m, 4.5m and 1m respectively where the head and shoulders can be seen
- Any one fail means a rating of zero star
- The single vehicle that is 'just' below these threshold values defines the volumetric score for the 1 star
- Other star ratings are defined by an equal subdivision of the volume between the 1 star vehicle and the best performing vehicle

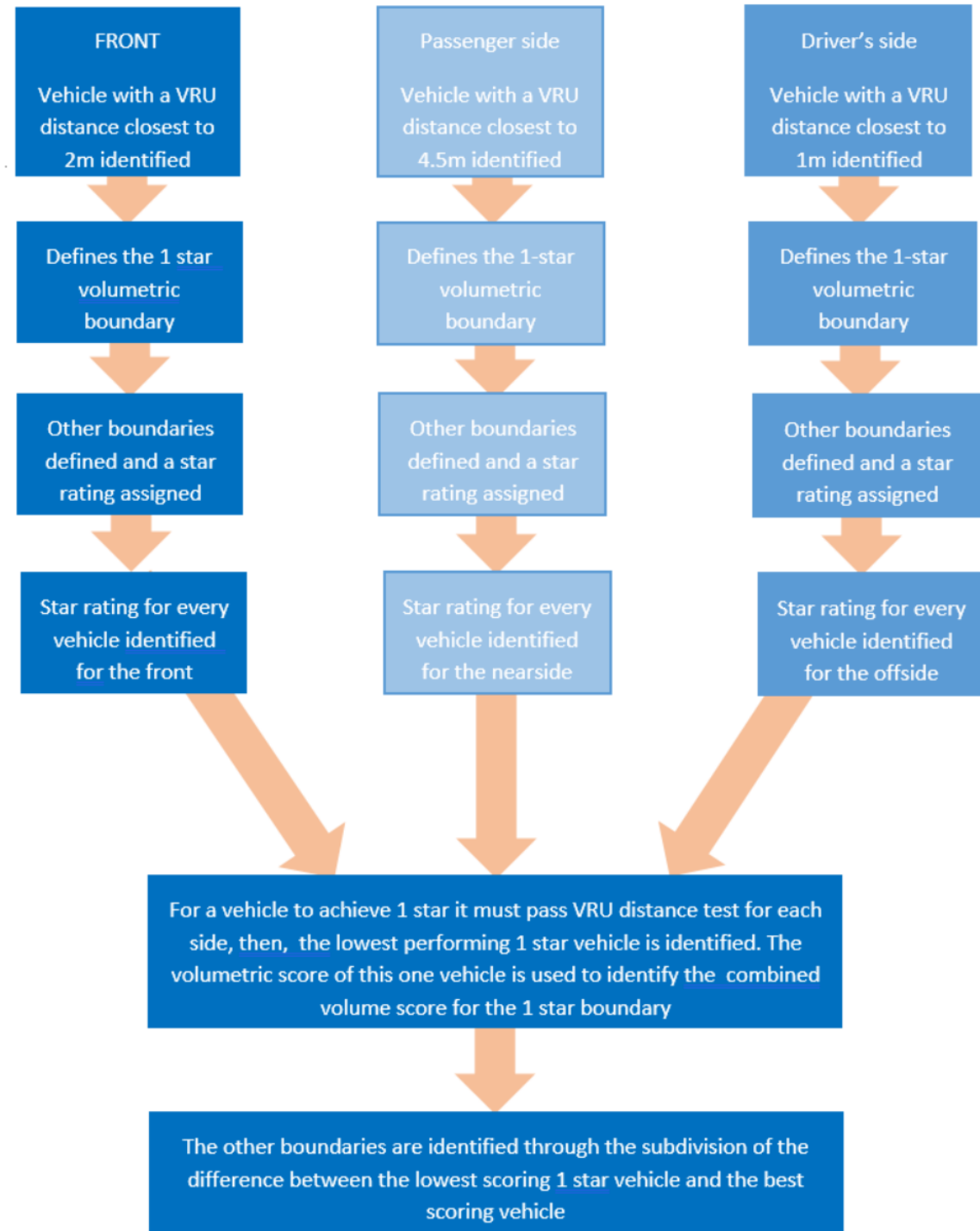

# Methodology

- The LDS team have developed a tool which allows the automatic production of look up table values
- This system allows volumetric scores to be produced in 1mm increments, 1 per second vastly increasing the productivity of the work flow (compared to 20 minutes per 1mm increment if done manually)

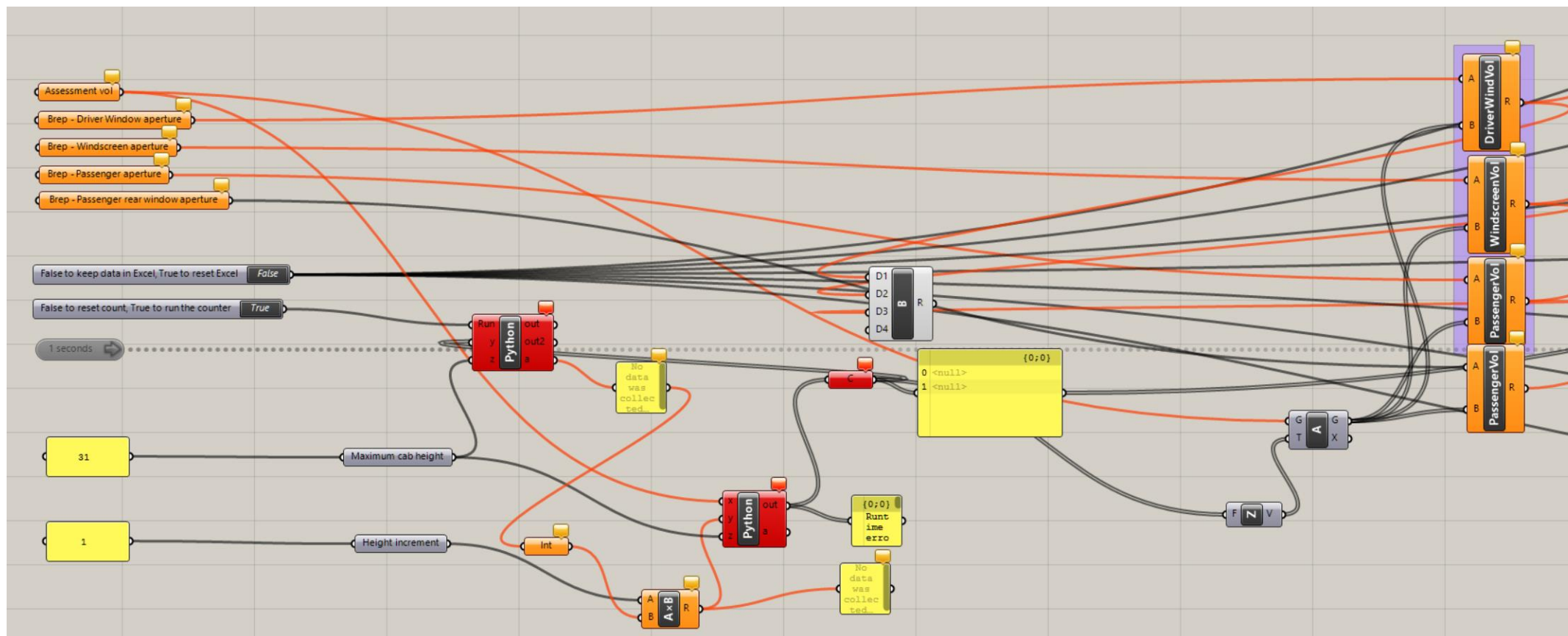

---

The sample



# The Sample

- Most vehicle manufacturers provided CAD data but we had to 3D scan some vehicles
- Subsequently the Volvo FL has been added
- MAN TGS and MAN TGM and Isuzu trucks will be added to sample
- To ensure a fair analysis of cab design performance each cab design has been tested at it the **maximum** and **minimum** possible mounting heights above the ground with variability due to differences in specification for engine, suspension, axel and tyre types.
- 50 vehicle conditions are included in the current data set

Make & model	CAD DATA	Height data
DAF CF N3, N3G (Highest, Lowest & Most Sold)	CAD data provided	All height range data
DAF XF (Highest lowest & most sold)	CAD data provided	All height range data
DAF LF	CAD data provided	All height range data
Dennis Eagle Elite 6	CAD data provided	All height range data
MAN TGS N3, N3G (Highest, lowest & most sold)	Scan data used	Body builder data used
MAN TGX N3, N3G (Highest & lowest))	Scan data used	Body builder data used
Mercedes 2.3 (Highest & lowest)	CAD data provided	Min/max only
Mercedes 2.5 (Highest & lowest)	CAD data provided	Min/max only
Mercedes Atego ((Highest & lowest)	CAD data provided	Min/max only
Mercedes ECONIC	CAD data provided	single height
Renault D 2.3 (Highest & Lowest)	CAD data provided	Min/max only
Renault C 2.5 (Highest & lowest)	CAD data provided	Min/max only
Renault K (Highest & lowest)	CAD data provided	Min/max only
Renault T RM (Highest & lowest)	CAD data provided	Min/max only
Scania P (Highest & lowest)	Scan data used	Min/max only
Scania R (Highest & lowest)	Scan data used	Min/max only
Volvo FE LEC (Most Sold)	CAD data provided	Min/max only
Volvo FH (Highest & lowest)	CAD data provided	Min/max only
Volvo FM (Highest & lowest)	CAD data provided	Min/max only
Volvo FMX (Highest & lowest)	CAD data provided	Min/max only
Iveco Stralis	CAD data provided	No data supplied

---

## The results

# The results: Volume plotted against average VRU distance

AVERAGE VRU DISTANCE ALL SIDES

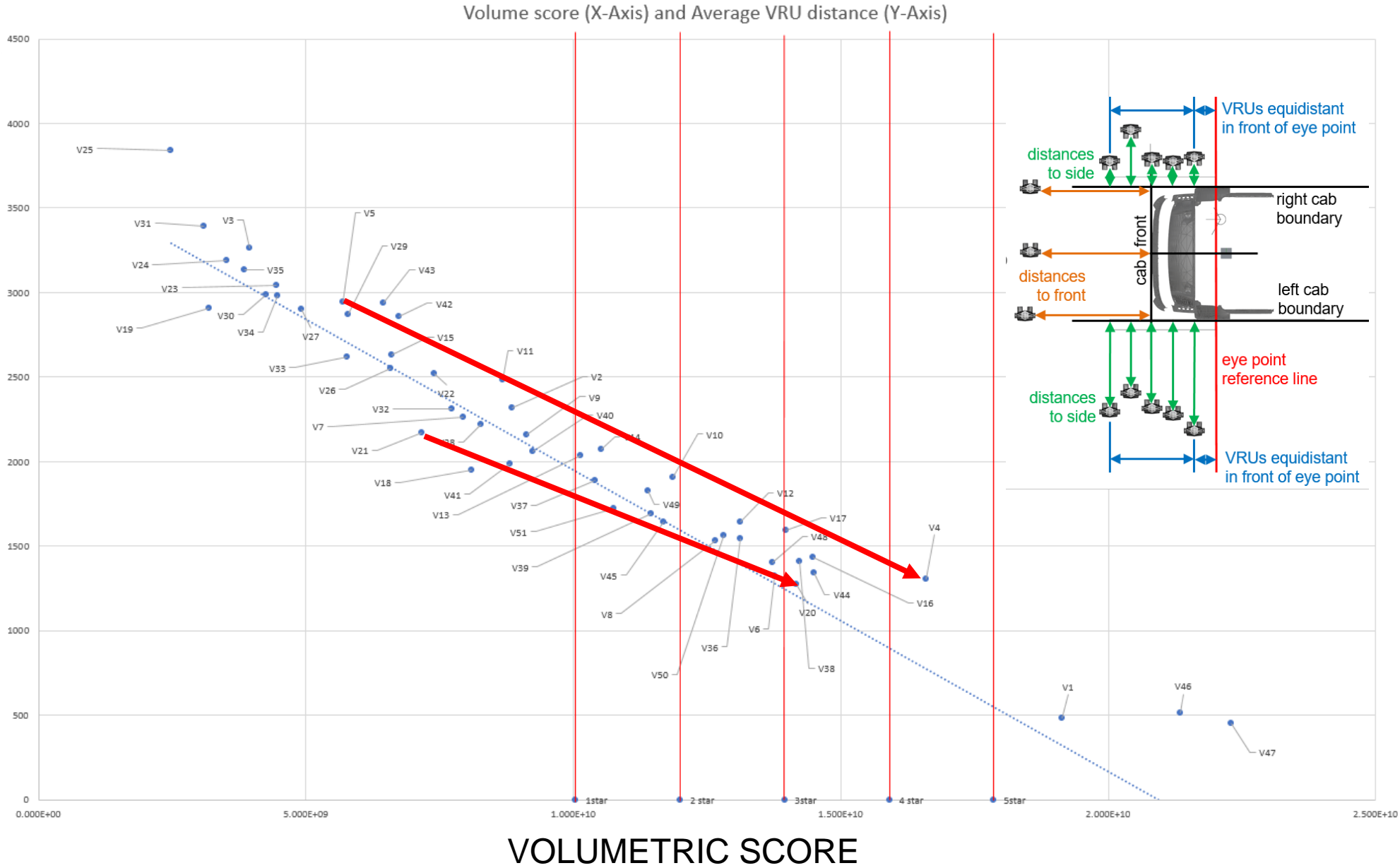

The vehicles analysed include the highest and lowest possible versions for each cab design e.g. V5 & V4 are the same cab at max & min heights

# The results: Volume plotted against VRU distance

AVERAGE VRU DISTANCE ALL SIDES

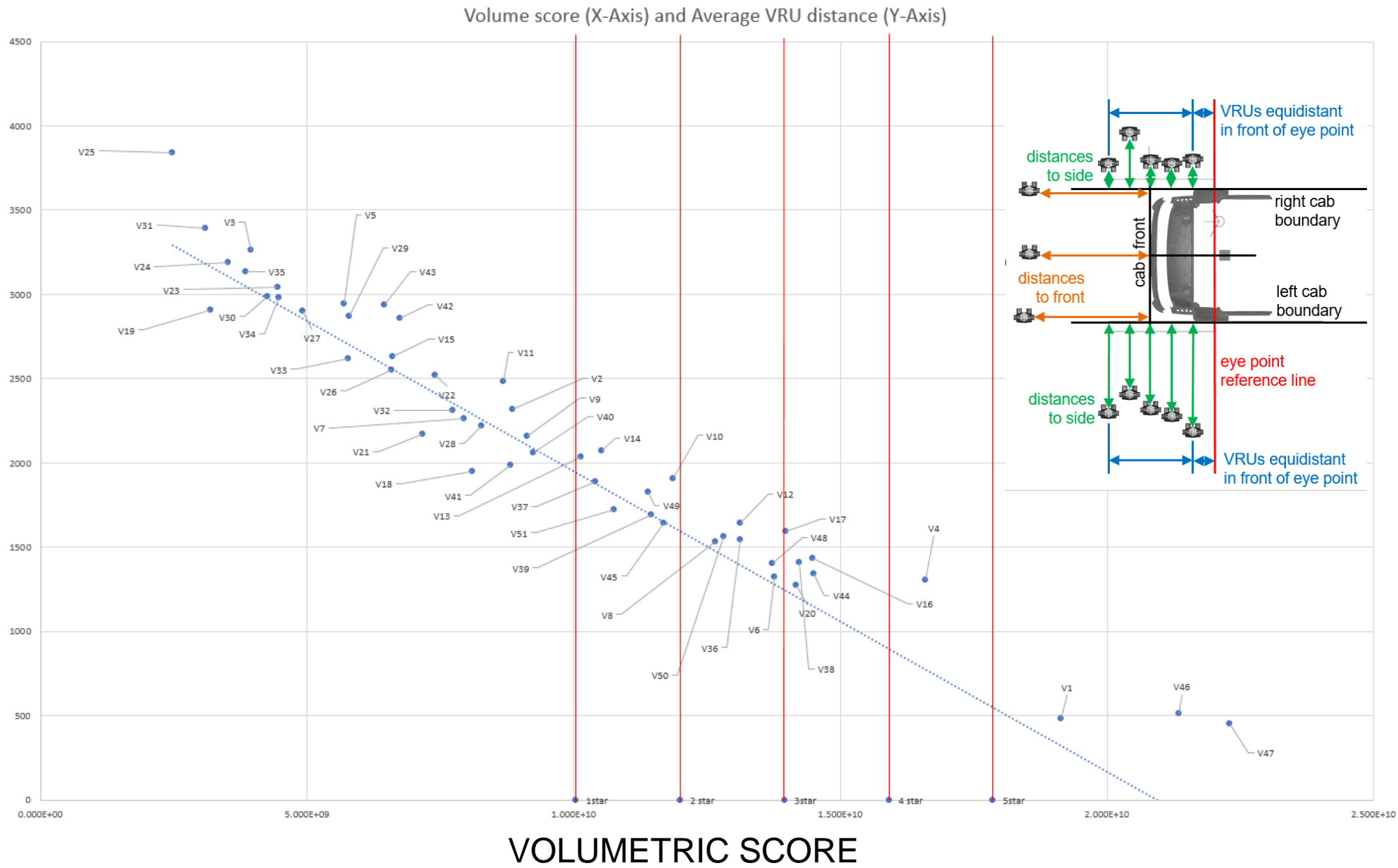

**0.97 correlation between volume scores and VRU scores : 0.5 is strong, 1 is perfect**

## Standard cab design which meet the minimum DVS requirement (1 star)

---

The following manufacturers produce designs which meet the minimum requirement of 1 Star  
(Some MAN vehicles yet to be added to the sample).



---

## The development of the generic truck model for the validation of CAD tools used by manufacturers

## The development of the generic truck model for the validation of CAD tools

- We have developed a **generic truck model**
- This can be used to **validate the results** of different CAD system before a DVS analysis is undertaken
- This is included in the protocol as a requirement prior to analysis
- **Two manufacturers have tested this so far and found a difference in the result of 0.25% compared to those produced by the LDS team.**
- This tolerance is considered to be appropriate
- A tolerance of this order has been examined with reference to the rating boundaries, and a result of plus or minus 7mm was found

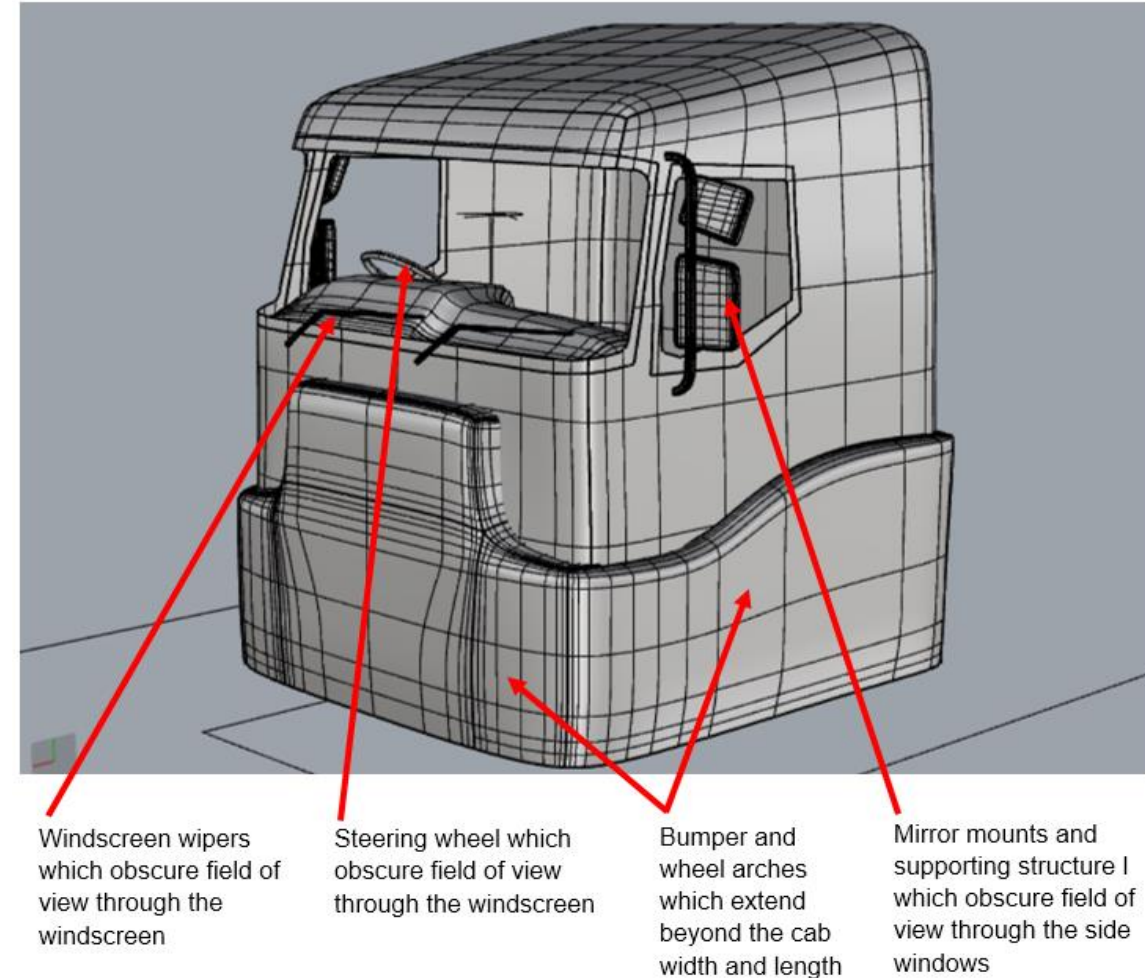

## The development of the standard generic truck model for the validation of CAD tools

---

- The generic truck model is provided with the eye rig and assessment volume already aligned to reduce errors in the CAD tool results comparison
- The obscuration paths and final volumes are also included for comparison
- The file has been released for use by manufacturers along with a draft protocol for comment

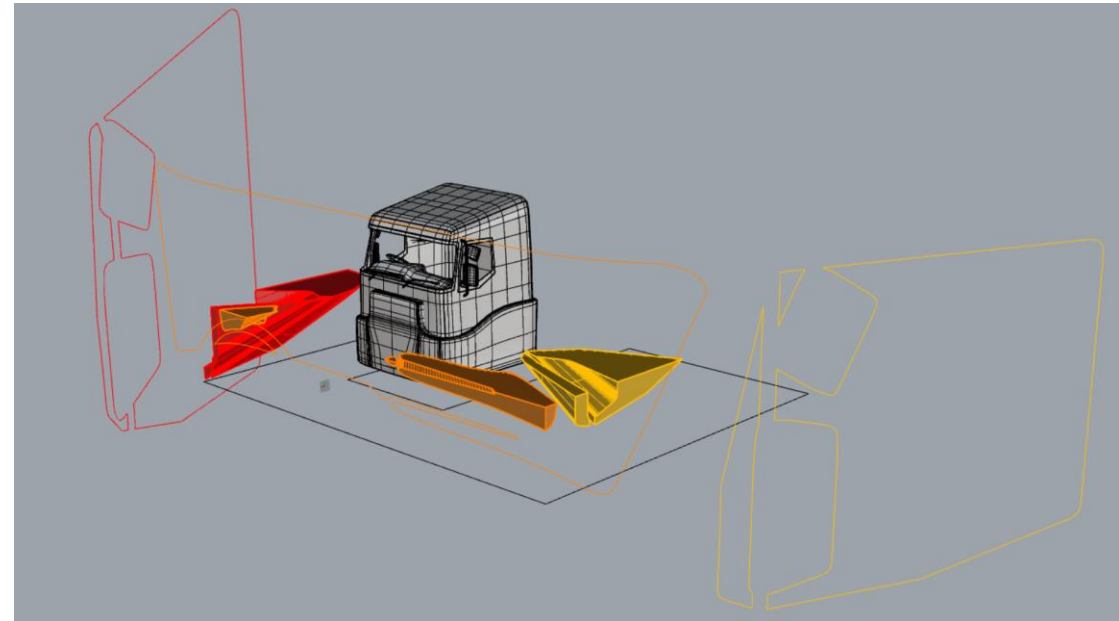
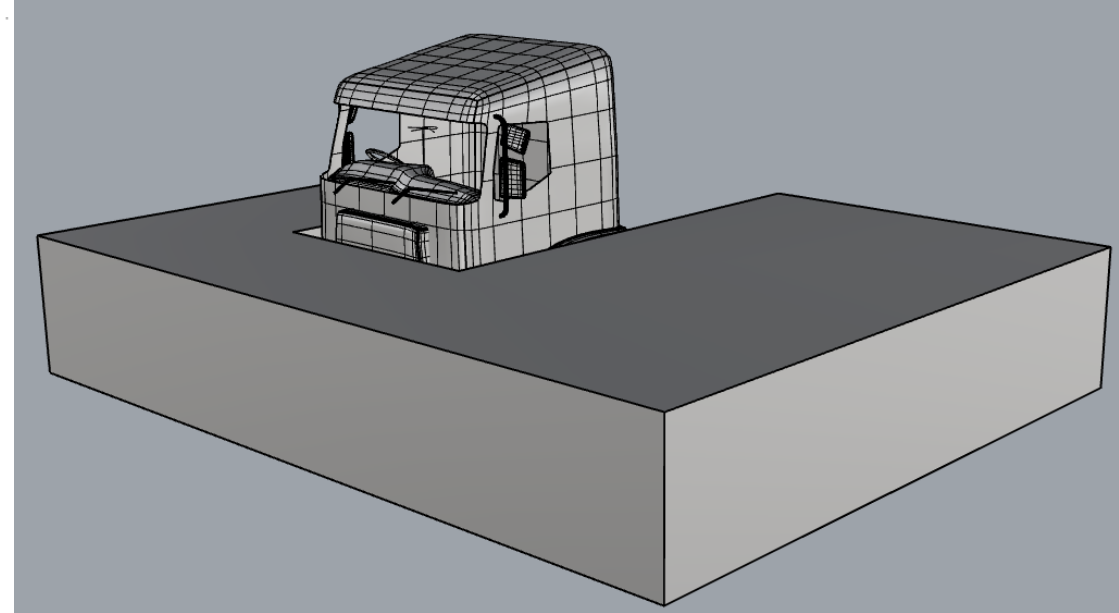



# The protocol

- The protocol has been produced in terms of the process required to find the DVS scores of a vehicle
- This has been distributed to manufacturers in draft form
- The protocol needs to be further developed to include the reporting method to TfL along with standard references to existing standards that influenced the TfL DVS design

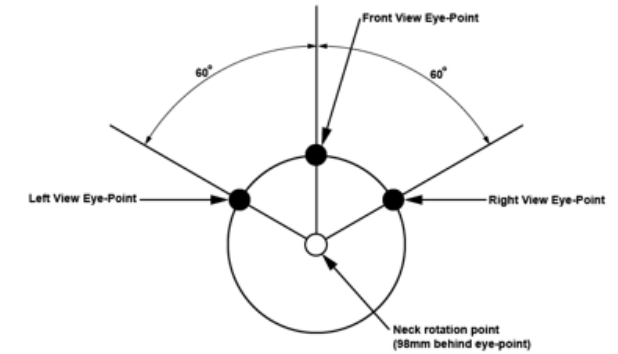

Figure 6. Plan view of the eye rig that is required for the three eye positions

### 1.3.6 CREATING CAMERAS TO SIMULATE THE VIEWS

Camera views must be created from each eye point. The front view must be looking straight forward; the left and right views are rotated 60 degrees from the front view (rotated through a point 98mm behind the eye-point). It can be useful to create 'Look at' locations for setting the camera views (see Figure 7).

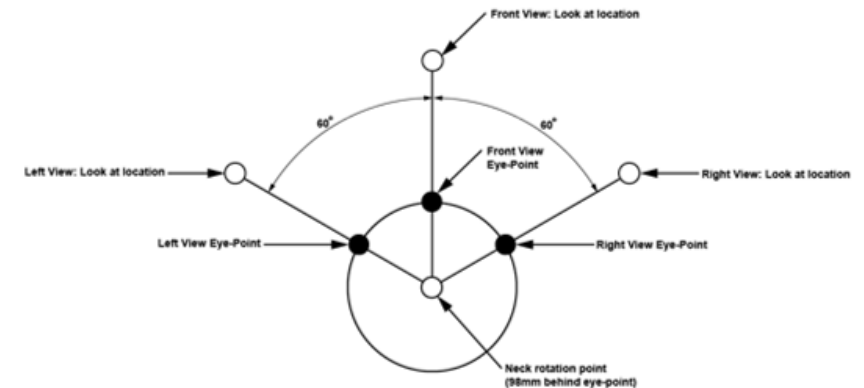

Figure 7. Setting up camera views required for projection

## The proposal at European level

---

- The project has highlighted that direct vision performance of some HGVs can not meet the minimum requirement defined for the TfL DVS 1 star for direct vision
- This is not seen as acceptable and it is recommended that the 1 star boundary is set as a minimum requirement
- The project has also highlighted that standard truck designs (not low entry cabs) can meet this standard and that many manufacturers are already able to meet the minimum requirement
- There is a need for further discussion about the effects of this recommendation, including the effects on vehicles which are not generally used in Urban areas

# The proposal at European level

- One proposal which reflects this is to define a **differentiated approach** that considers the environment of use of the vehicle as shown in the table below with a staged approach allowing manufacturers who cannot currently meet the minimum requirement to improve designs
- The DVS methodology supports manufacturers in doing this as they can test different variants

Vehicle classification	DVS volumetric score	Av. VRU distance	2024	2025	2027	2030
DVS Class 1	10.04m <sup>3</sup>	2000mm	Long Haul (LH)			
DVS Class 2	11.99m <sup>3</sup>	1650mm	Construction (C), Regional Delivery (RD)		Long Haul (LH)	
DVS Class 3	13.95m <sup>3</sup>	1250mm	Urban Delivery (UD), Municipal Utility (MU)	Regional Delivery (RD)	Construction (C)	
DVS Class 4	15.90m <sup>3</sup>	800mm			UD & MU	RD, LH, C
DVS Class 5	17.86m <sup>3</sup>	600mm				

## Why is this method better than a real world test?

---

- Highly accurate based upon the CAD data used by manufacturers for the vehicle production process
- Provides a **three dimensional analysis** for a **three dimensional problem** that allows vehicle designers to see the benefits of design changes to the DVS score
- **Real world tests** use **vision markers** such as **cones** to define direct vision in a similar manner to the VRU simulations in our system. This however provides a **small number of data points** (50?) compared to the CAD based data which has thousands of data points. **Our approach is much more accurate**
- Other real world tests such as shadow projection from a light source at the eye point define a two dimensional projection on flat surfaces which then have to be manually captured. **These data again do not represent the three dimensional problem that is explored in the CAD version with ease**

# Summary

---

- The LDS team has defined the DVS to be fit for purpose
  - This has involved the definition of the **DVS assessment zone**
  - The modelling of over 50 vehicles and the testing of this sample against **6 different versions** of the DVS and the various processing options
  - The **quantification** of the volumetric results **using VRU simulations** that links the volumetric results to real world implications
  - Defined a **Star Rating method** that is linked to the VRU simulation data but relies upon the accurate and high resolution volumetric data
  - Applied this method in four different ways to provide options with increasing numbers of vehicles with zero star ratings
  - Defined a robust methodology that has been agreed with manufacturers and is currently being applied by all manufacturers for the London system
    - As an example two manufacturers have provided results for the Generic truck design which were 0.25% different from the results calculated by the LDS team
- We recommend this approach to the UNECE

## Project information

---

Thank you for your attention, are there any questions?

Dr Steve Summerskill (s.j.summerskill2@lboro.ac.uk)

Dr Russell Marshall

Dr Abby Paterson

Anthony Eland

Design Ergonomics Group

Loughborough Design School

Loughborough University

United Kingdom