

## False reaction test Car to Car

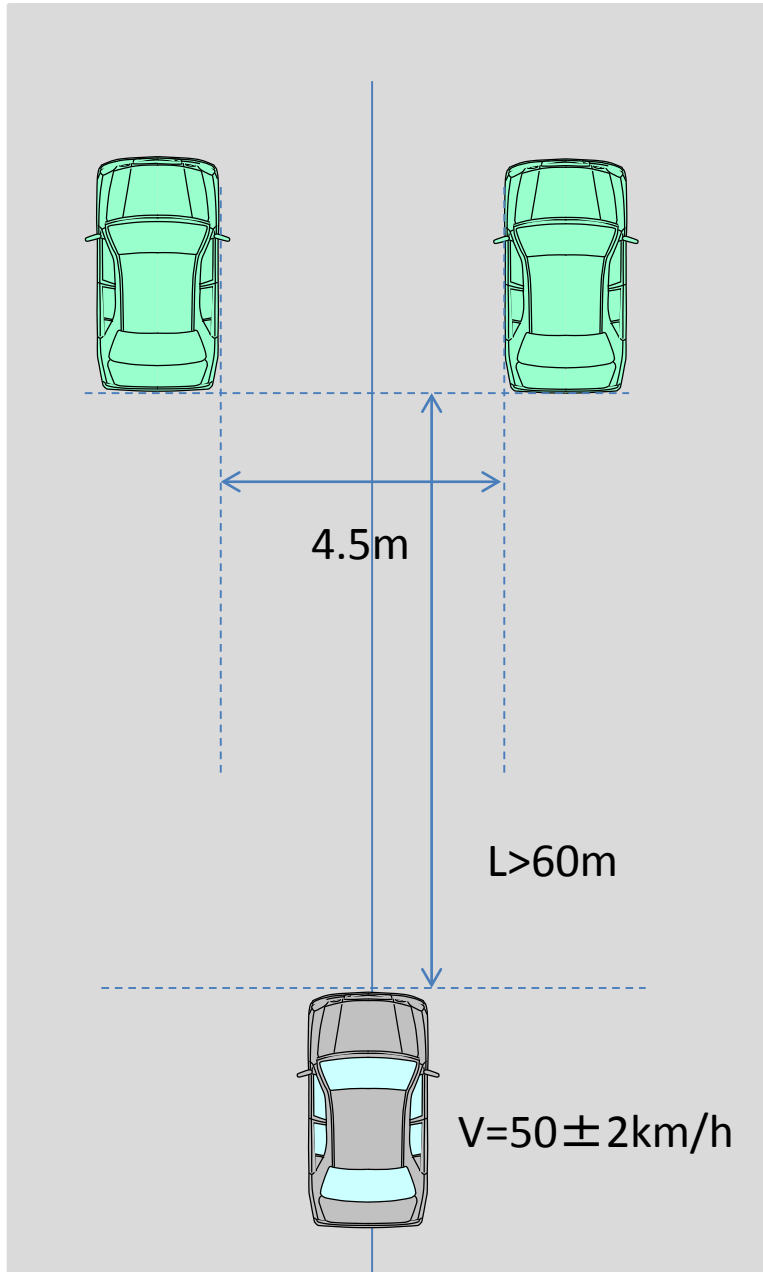

### Category M1 AA saloon

- (a) So as to face in the same direction of travel as the subject vehicle,
- (b) With a distance of 4.5 m between them,
- (c) With the rear of each vehicle aligned with the other.

The subject vehicle shall travel for a distance of at least 60 m, at a constant speed of  $50 \pm 2$  km/h to pass centrally between the two stationary vehicles.

During the test there shall be no adjustment of any subject vehicle control other than slight steering adjustments to counteract any drifting.

## False reaction test Car to Pedestrian

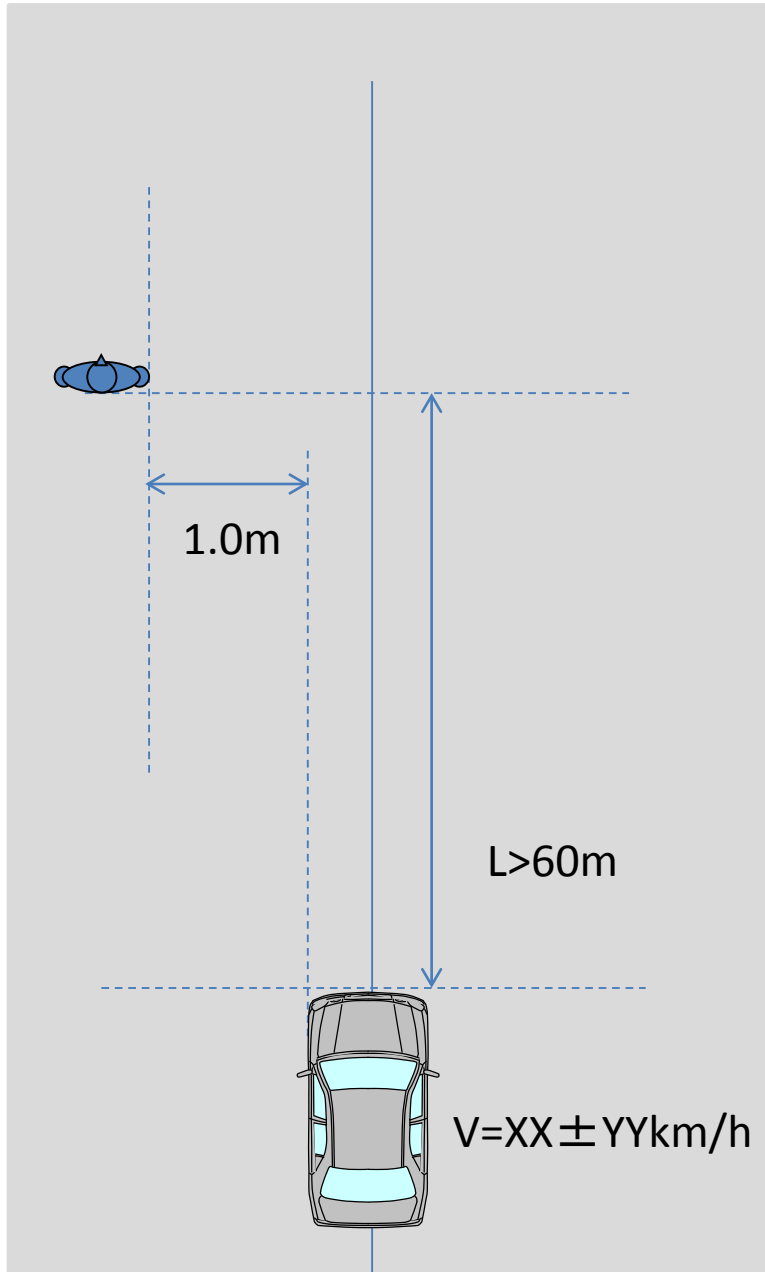

VRU Soft Target

- (a) So as to face in the same direction of travel as the target,
- (b) With a distance of 1.0 m between Vehicle under test and Target,

The subject vehicle shall travel for a distance of at least 60 m, at a constant speed of  $[XX \pm YY] \text{ km/h}$  to pass centrally between Vehicle under test and Target.

During the test there shall be no adjustment of any subject vehicle control other than slight steering adjustments to counteract any drifting.

## False reaction test Car to Cyclist

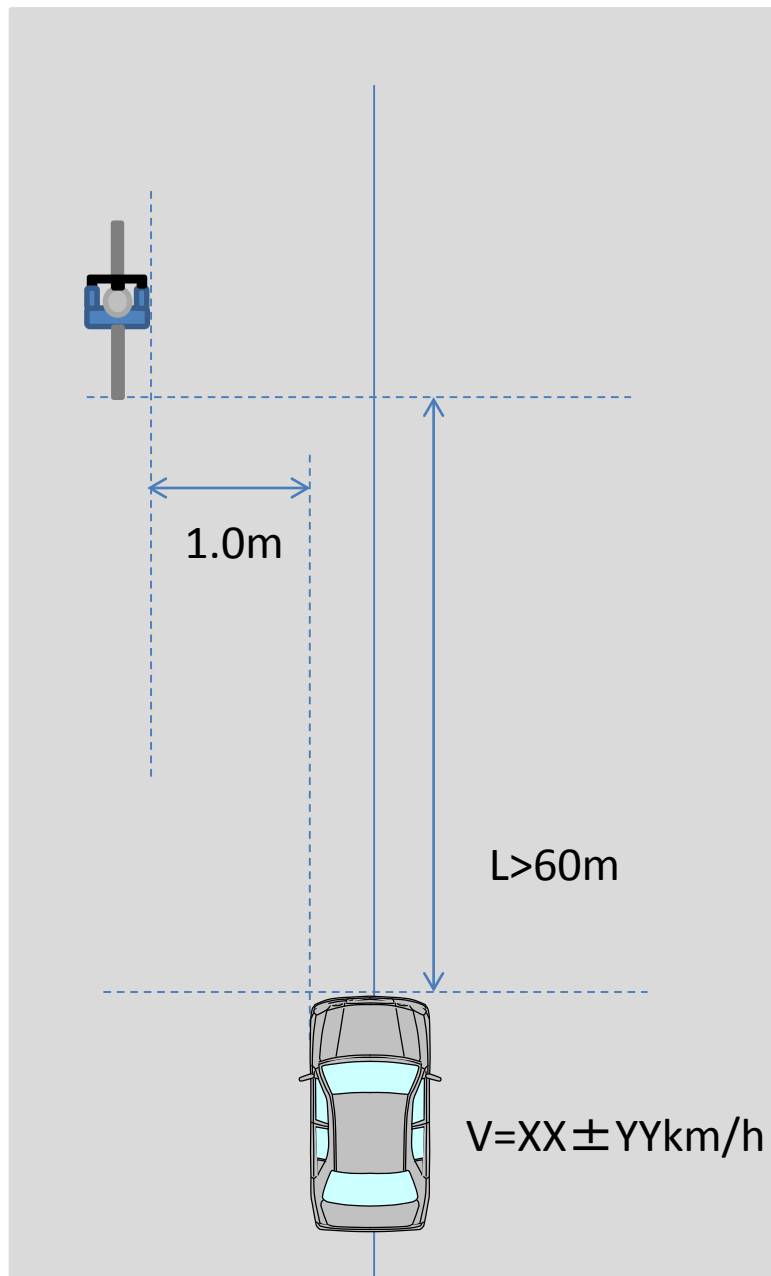

VRU Soft Target

- (a) So as to face in the same direction of travel as the target,
- (b) With a distance of 1.0 m between Vehicle under test and Target,

The subject vehicle shall travel for a distance of at least 60 m, at a constant speed of  $[XX \pm YY]$  km/h to pass centrally between Vehicle under test and Target.

During the test there shall be no adjustment of any subject vehicle control other than slight steering adjustments to counteract any drifting.