

HGV Direct Vision Standard: London Update

Alina Tuerk
Delivery Planning Manager,
Transport for London

7th VRU-Proxi Meeting, Germany

26 September 2018



Vision Zero: No loss of life should be considered acceptable or inevitable

- The Mayor's Transport Strategy commits to a Vision Zero approach to road danger reduction

Eliminate death and serious injuries on our transport network by 2041

- The Vision Zero Action Plan



Safe Speed



Safe Roads



Safe Vehicles



Safe Behaviours



Developing a Direct Vision Standard (DVS) for HGVs

A measure



- The world's first and only HGV Direct Vision Standard
- It's an **objective measurement** of the visible 'volume of space'

A rating



- This measurement is converted to a 'star rating' from zero (worst) to five (best)
- Loughborough University have worked with the principal manufacturers

Application of DVS

- Informs operator purchasing decisions - most suitable vehicle for the city environment
- Manufacturers can use it to improve future designs
- Future European regulations governing HGV designs – an **International DVS**
- Accelerated adoption of safer HGVs in London
 - DVS and HGV Safety Permit Scheme
 - GLA/TfL contracts

Developing a Direct Vision Standard (DVS) for HGVs

A measure



- The world's first and only HGV Direct Vision Standard
- It's an **objective measurement** of the visible 'volume of space'

A rating



- This measurement is converted to a 'star rating' from zero (worst) to five (best)
- Loughborough University have worked with the principal manufacturers

Application of DVS

- Informs operator purchasing decisions - most suitable vehicle for the city environment
- Manufacturers can use it to improve future designs
- Future European regulations governing HGV designs – an **International DVS**
- Accelerated adoption of safer HGVs in London
 - DVS and HGV Safety Permit Scheme
 - GLA/TfL contracts

A collaborative approach

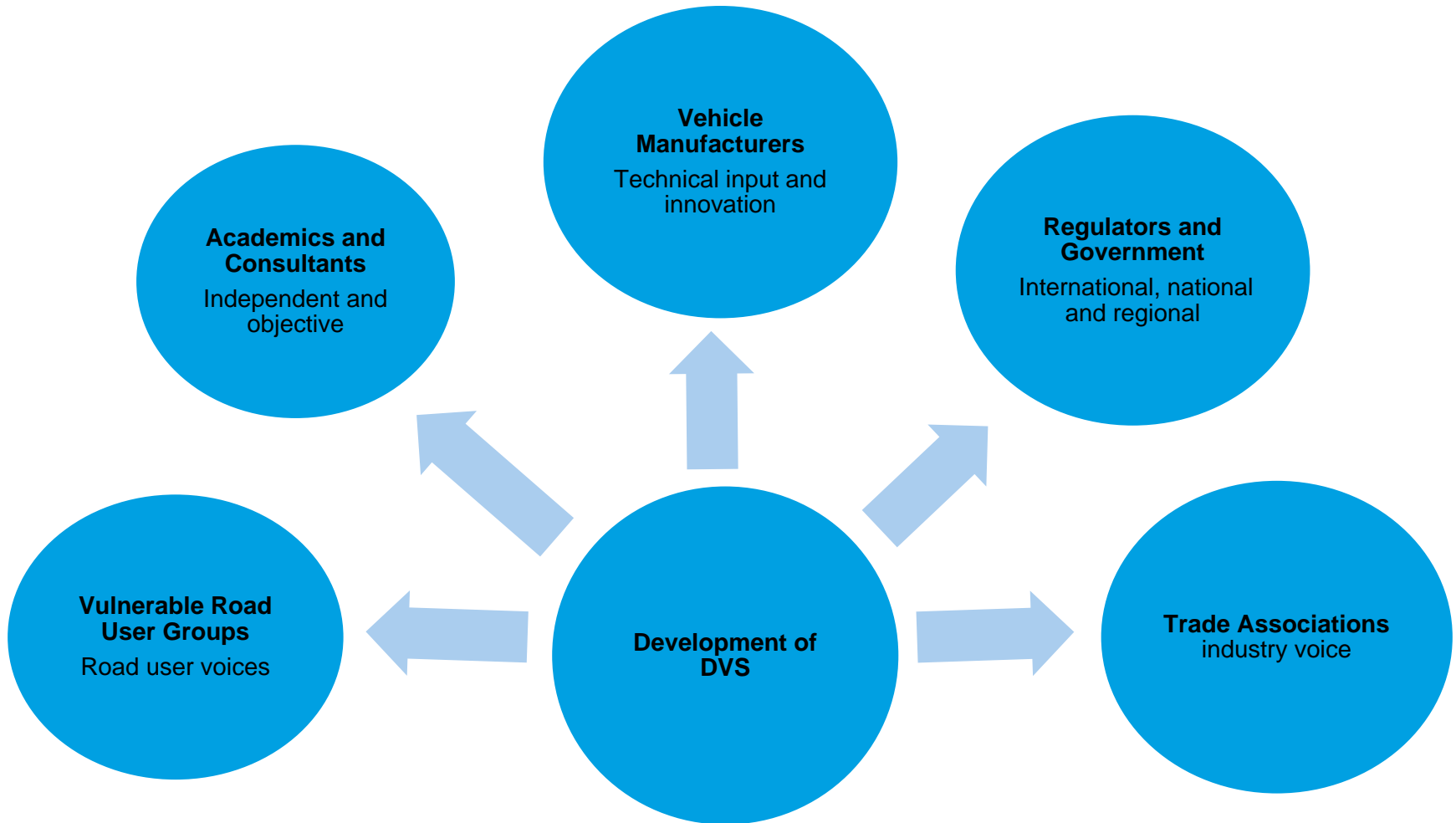

Proposal for London: HGV safety permit 2019/2020

2019: Permit issuing commences
Scheme 'go-live'

2020: all zero star HGVs banned unless
they prove a 'safe system'

2024: all zero - two star HGVs banned unless
they prove a 'progressive safe system'



Safe System

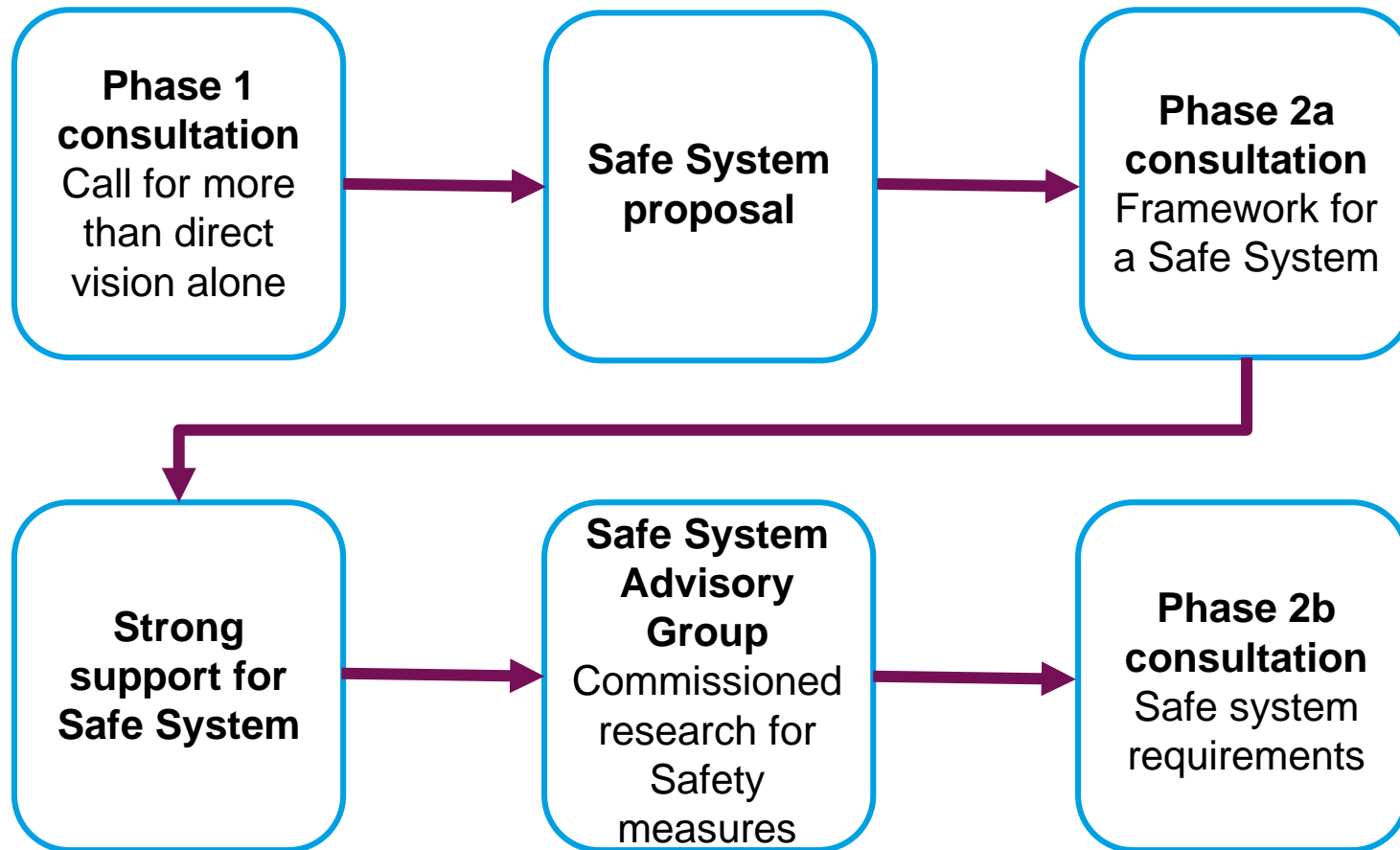

Obtaining a permit

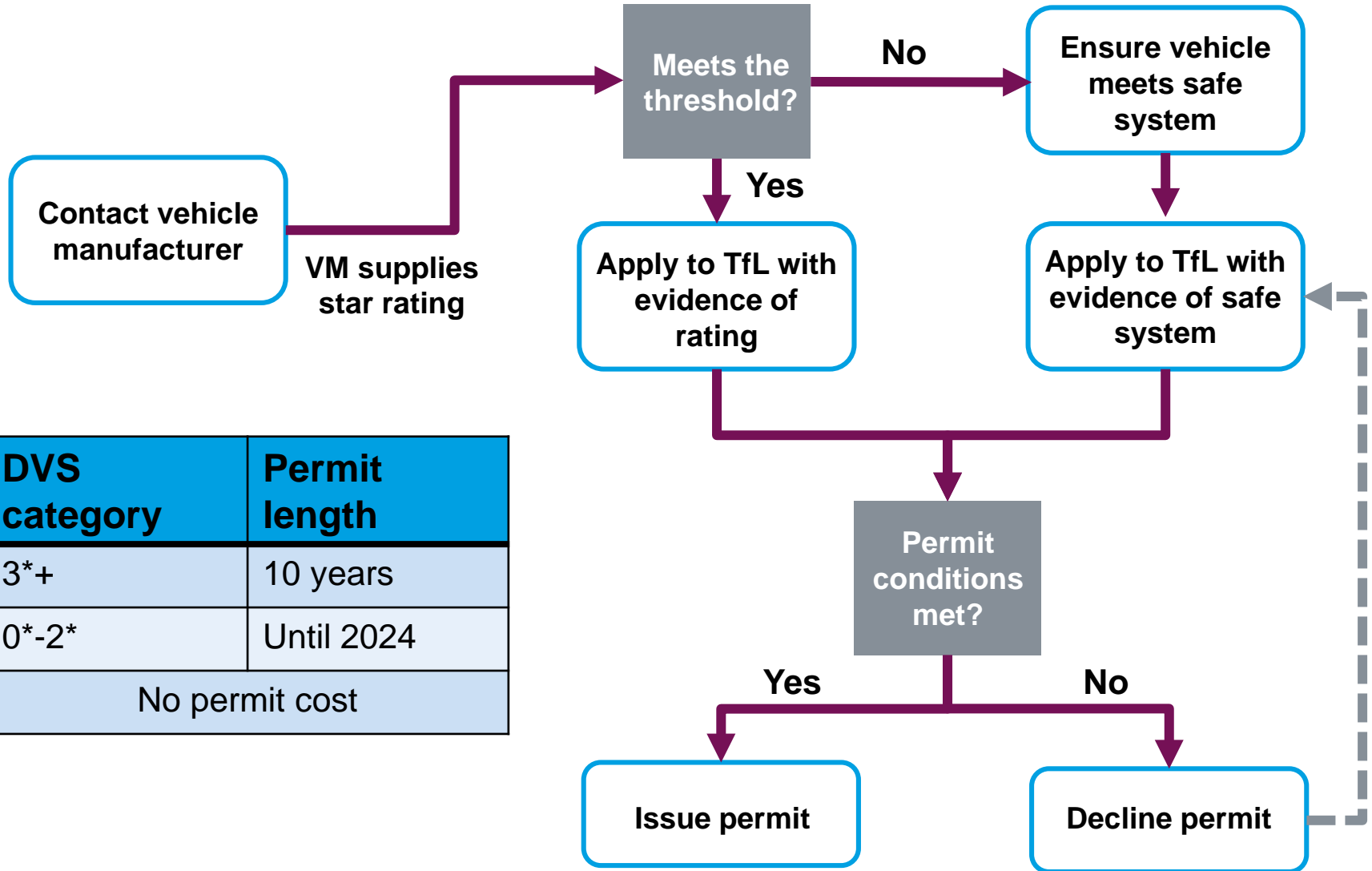

DVS category	Permit length
3*+	10 years
0*-2*	Until 2024
No permit cost	



Public consultation

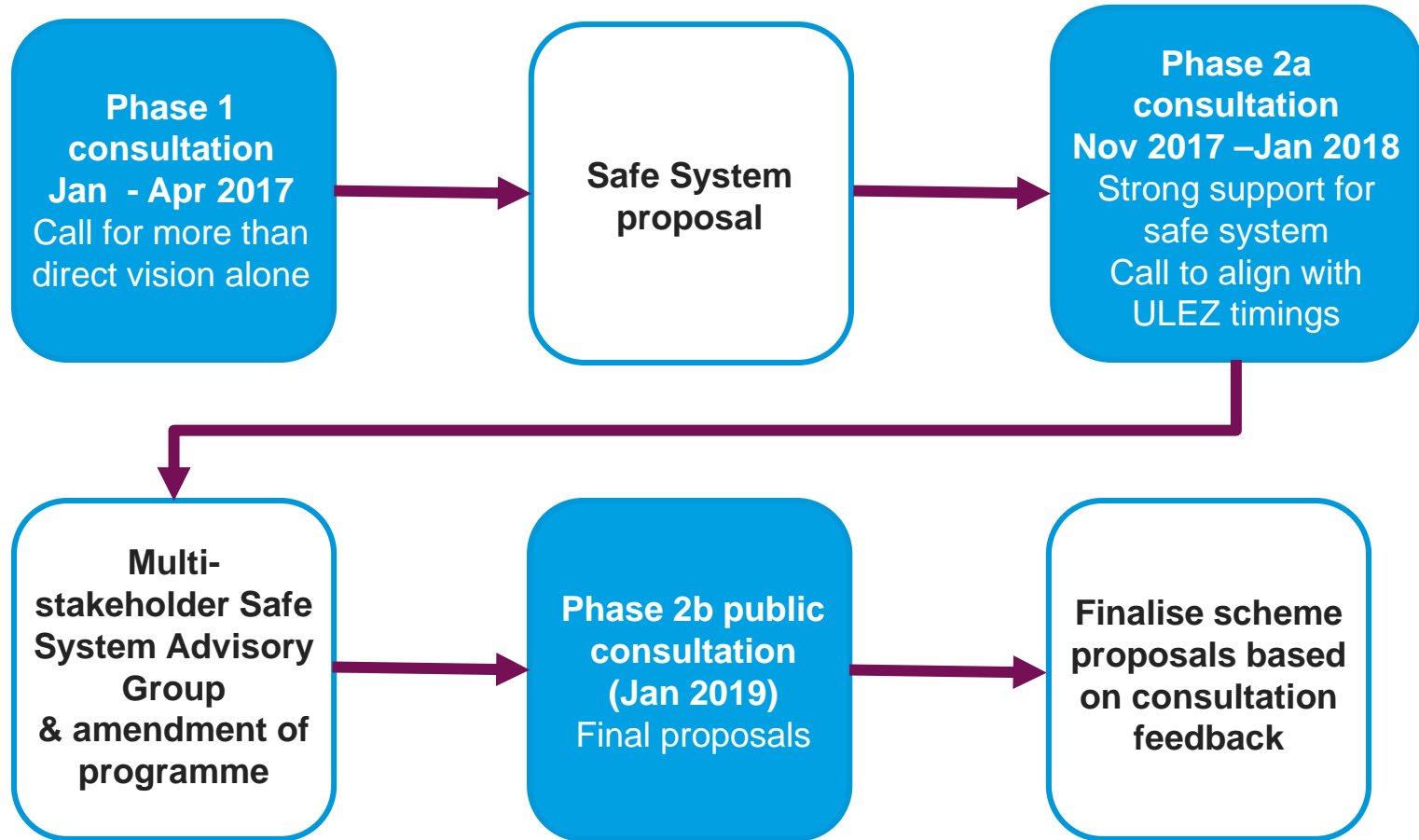

Contact

AlinaTuerk@tfl.gov.uk
+44 (0)207 027 9583



Definition and testing of a Direct Vision Standard for Trucks

Loughborough University Design School: Design Ergonomics Research Group
Research Sponsored by Transport for London

Dr. Steve Summerskill

Dr. Russell Marshall, Dr Abby Paterson, Antony Eland, James Lenard, Steve Reed

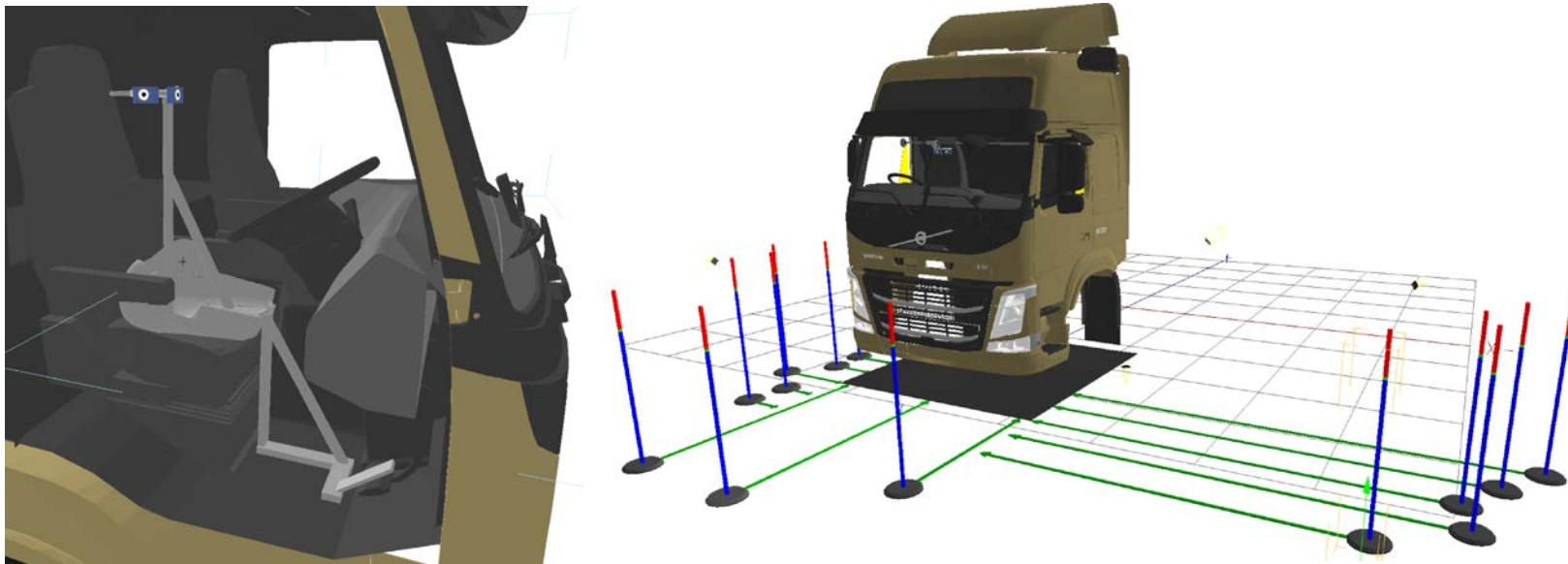

Contents

Detailed review of the work performed so far

- DVS Progress since the last VRU Proxy meeting
- The definition of a physical test that can be used for on the spot checks
- Potential option for differentiation between Urban/Long Haul/Construction vehicles

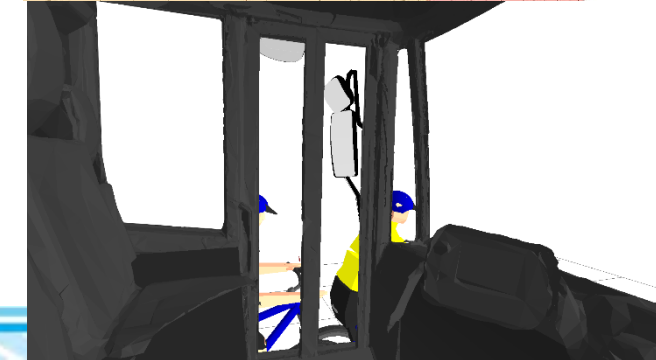
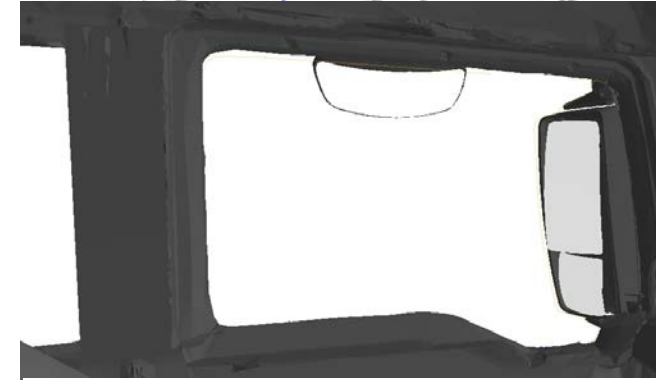
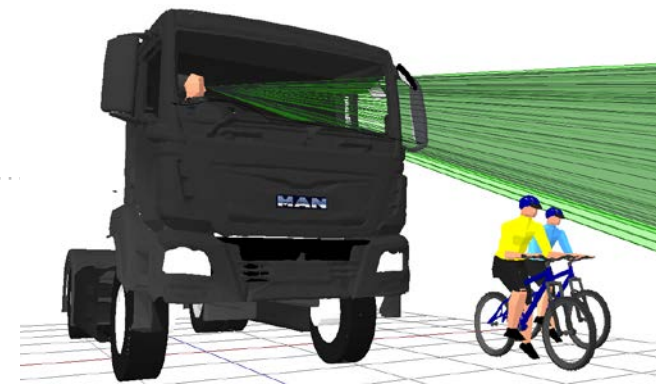

DVS Progress since the last VRU Proxy meeting

- Further refinement of the DVS protocol across a number of areas including;
 - The tightening of definitions for a number of variables including tyre sizes and an alternate method for the definition of the steering wheel position which avoids potential variability
 - Discussions are ongoing with manufacturers
 - Manufacturers are now in the process of piloting the DVS protocol
 - The 3D scanning of a selection of Euro IV / V vehicles to allow a DVS rating to be produced is ongoing with half of the sample now complete
 - This is to ensure that operators of older vehicles can obtain DVS scores where appropriate

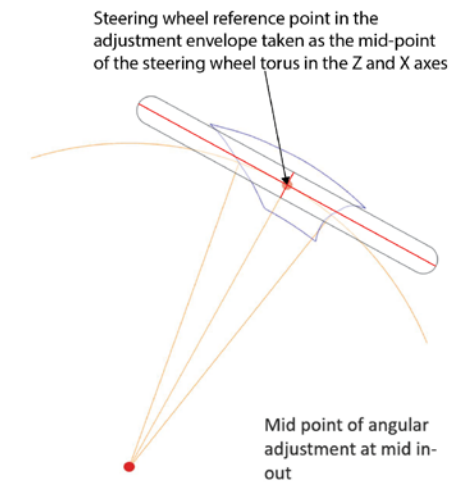
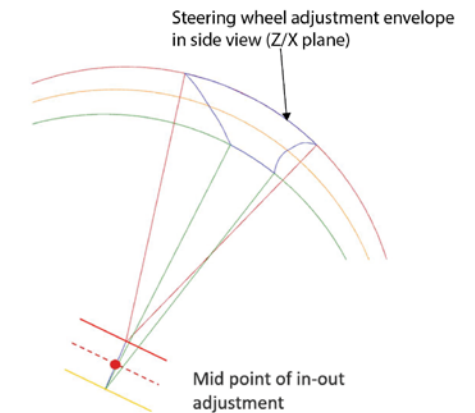

The definition of a 'real world' test that can be used for on the spot checks

- At the last VRU Proxy meeting we agreed to explore the design of a physical test that can be used in conjunction with the Virtual Technique
- As discussed at the last meeting the CAD approach should be seen as the gold standard in terms of the accuracy and ability to support the design process for improved direct vision, due to the high resolution nature of the test process
- The following should not be seen as a replacement for the CAD based technique
- In the last meeting we demonstrated how we used simulations of VRUs in CAD to validated the volumetric approach.
- The proposed 'real world' method uses a similar approach

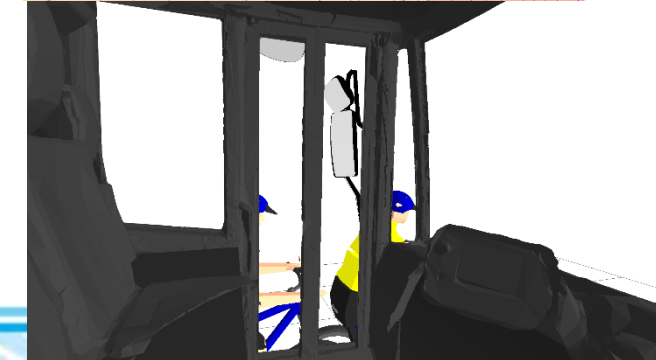
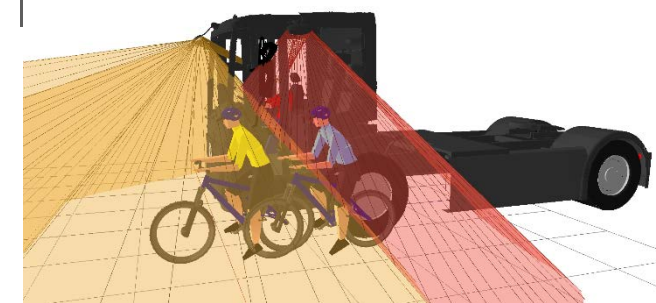
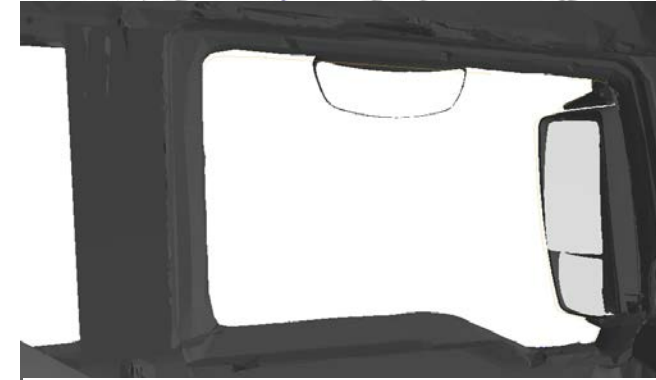
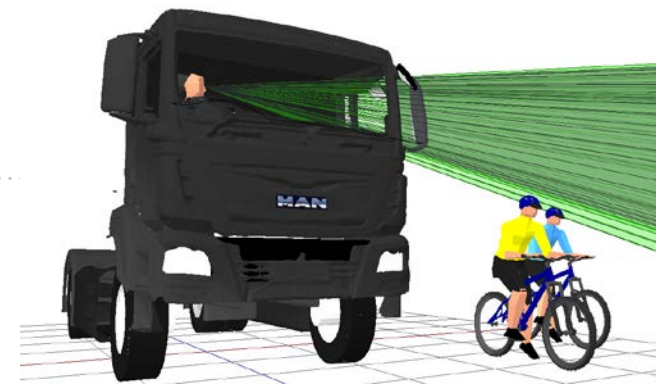

Reminder – the core DVS methodology

- The forward eye point is defined by an offset from the accelerator heel point (AHP)
- This eye point was defined with the agreement of manufacturers and is a standardised eye point which can be used with any vehicle
 - Multiple other options were considered including using standard hip point (SgRP) definitions and offsets for an eye point as defined in UNECE regulation 46, however these led to some manufacturers gaining an advantage when a full analysis of all trucks was performed due to variability in the use of the SgRP within the H-point envelope
- The eye point has been defined by taking into account the seat positions of all trucks (**common h-point location identified**), combined with an offset from the seat which replicates **average European eye height** for a truck driving posture
 - 50th percentile male and female offsets identified for **UK, Germany, Holland, France, Italy, Sweden** and then this is averaged with a 90:10 male female split.

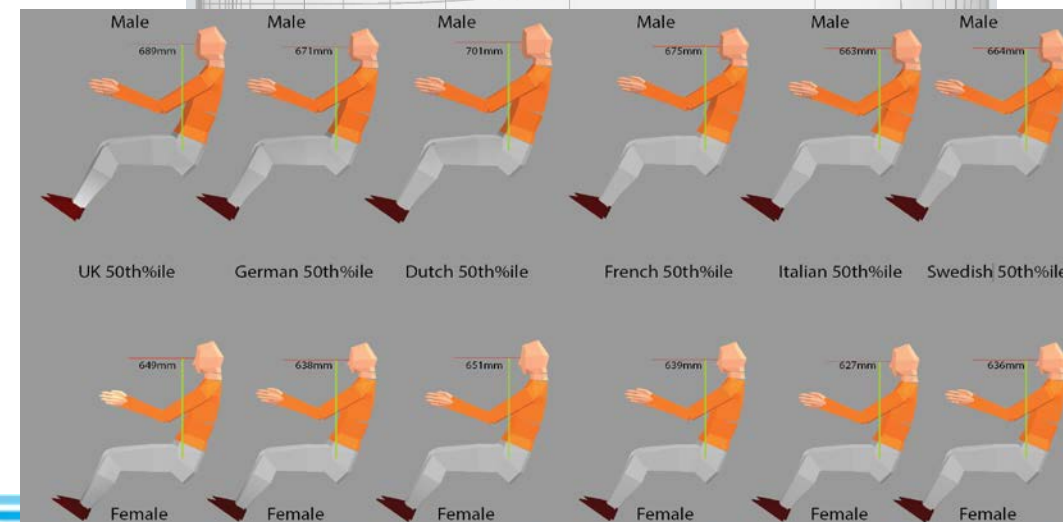
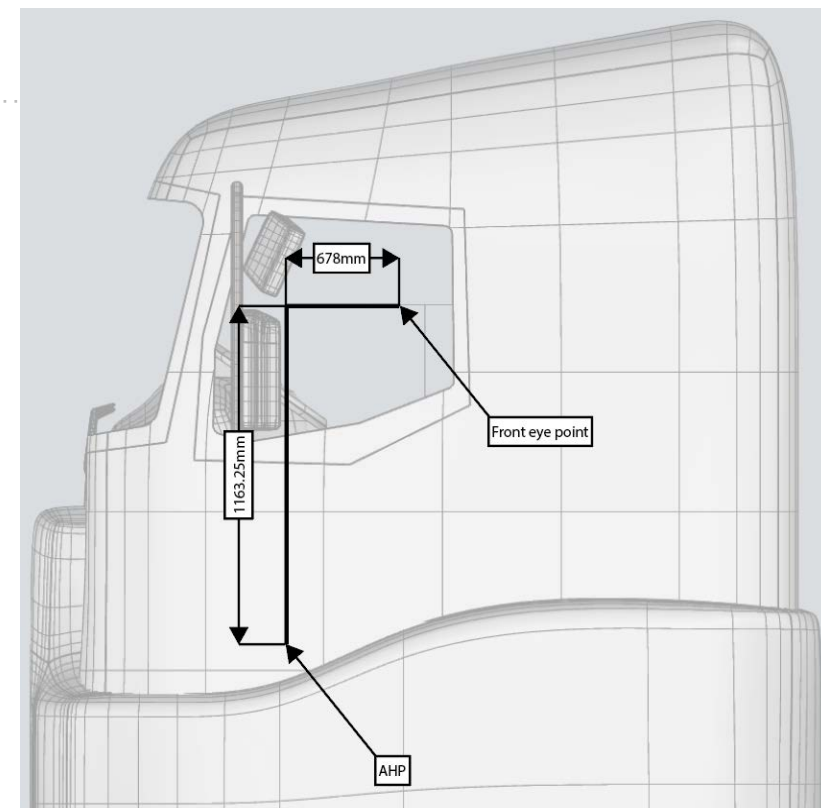

Reminder – the core DVS methodology

- The ‘eye rig’ is generated to simulate the view of virtual driver to the front, left and right of the cab using the premise defined by reg 125.

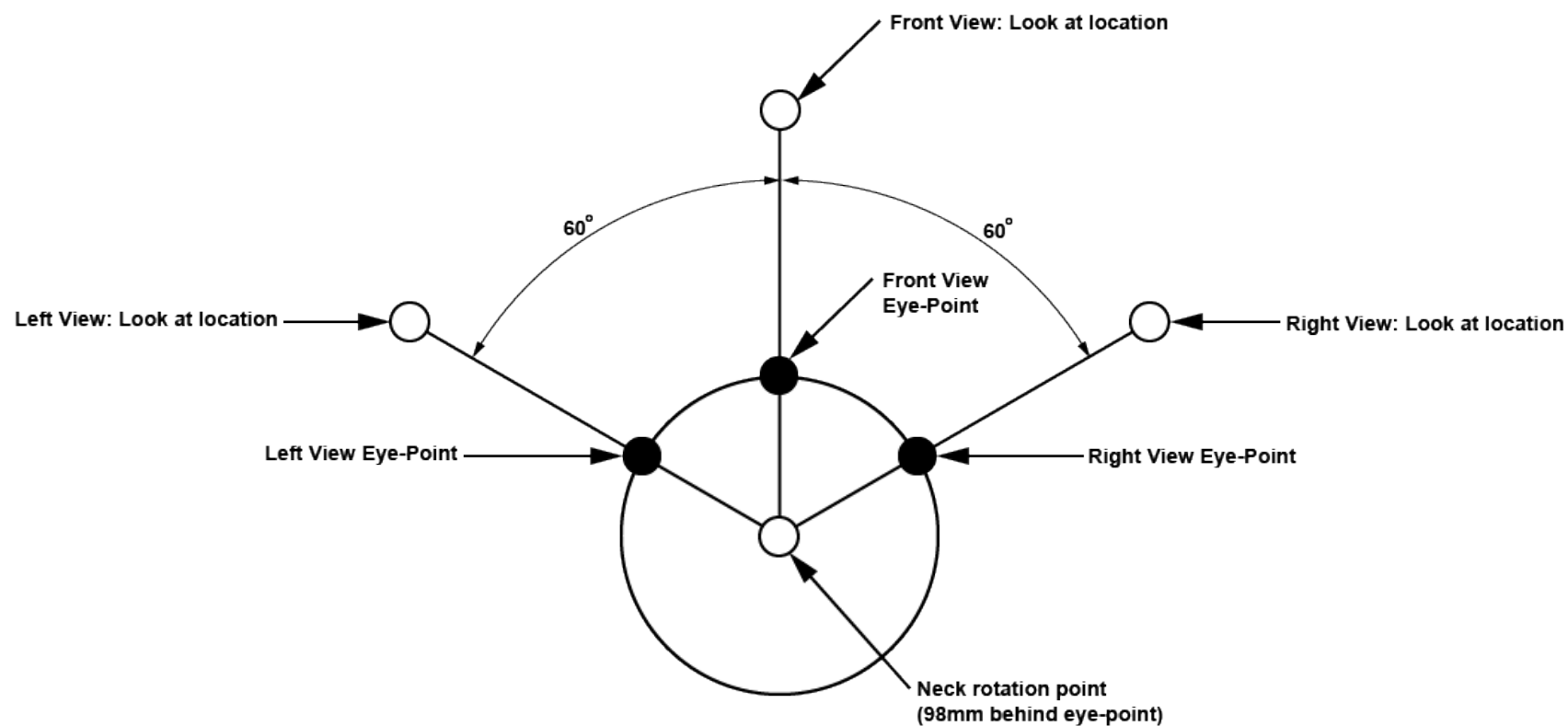

Reminder – the core DVS methodology

- The assessment volume is aligned to the truck sides and front

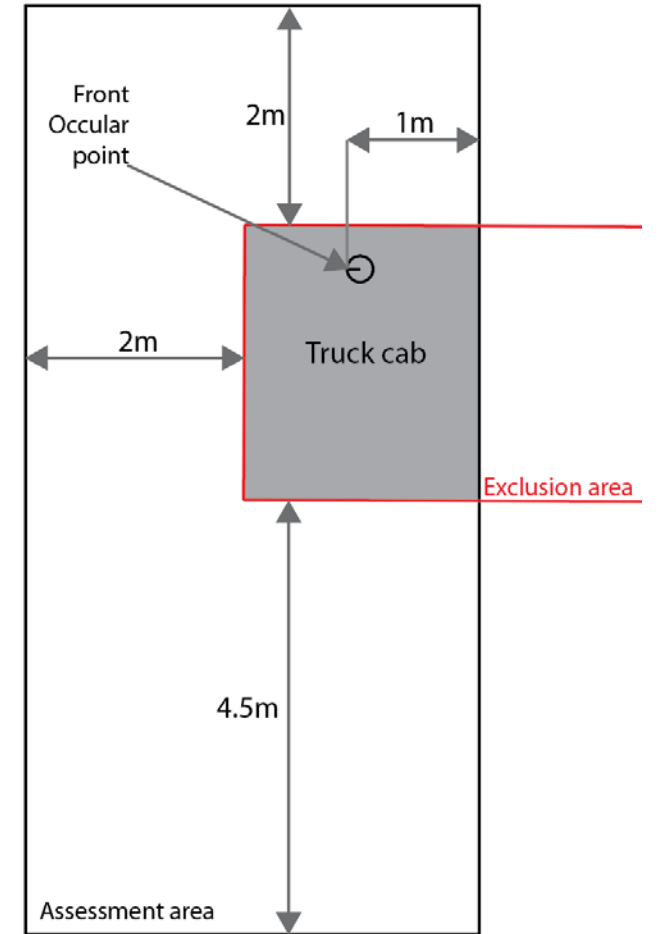
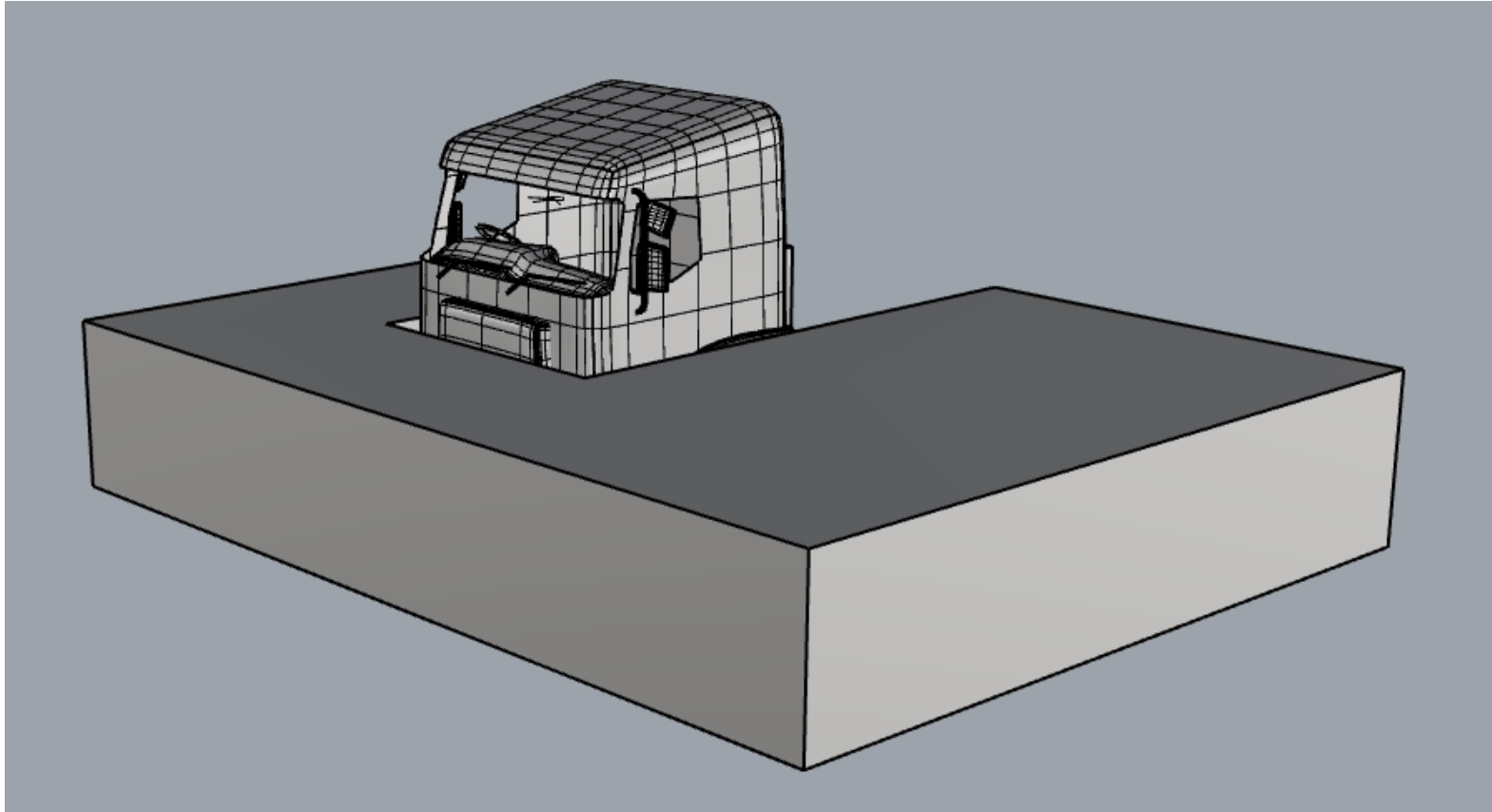

Reminder – the core DVS methodology

- The volume of space visible from the three defined eye points is projected

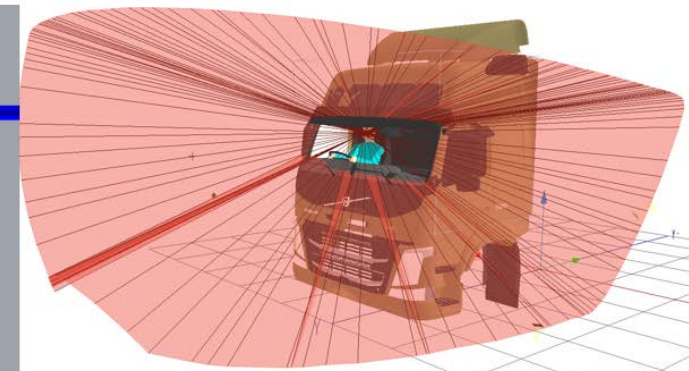
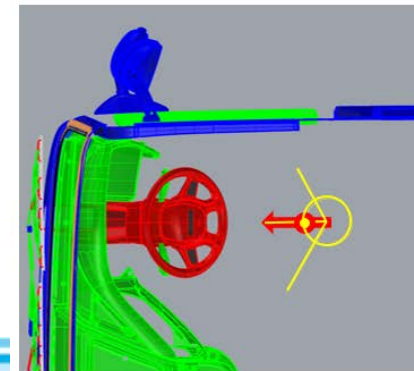
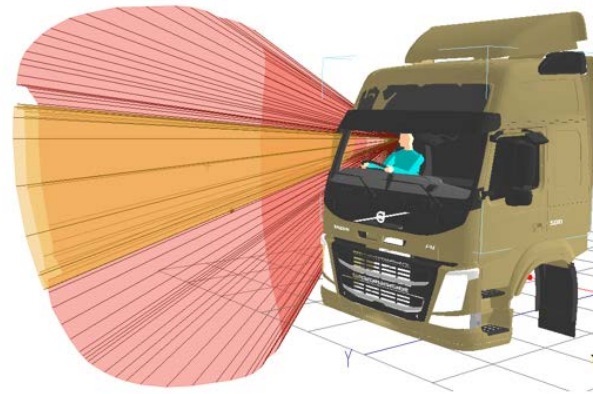
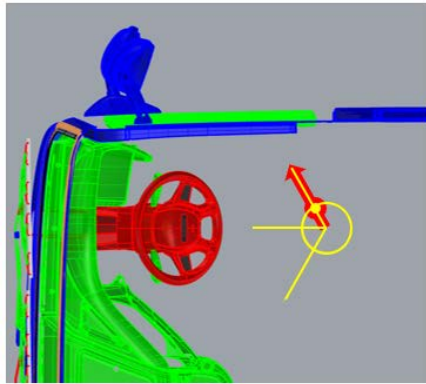
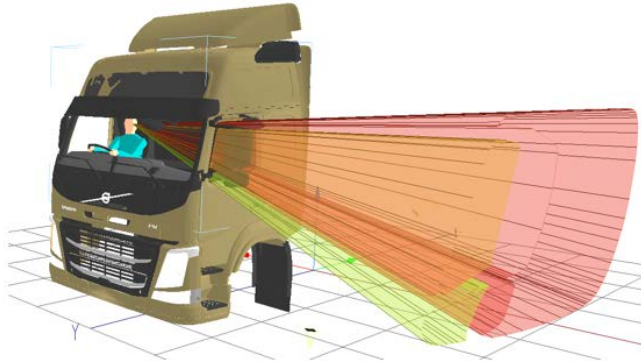
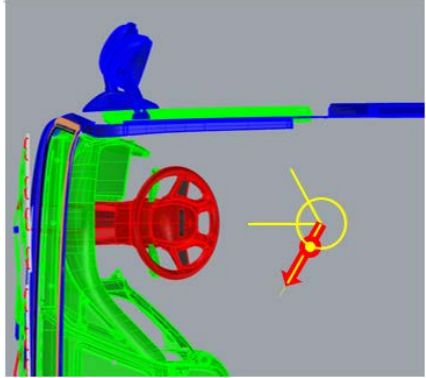

Reminder – the core DVS methodology

- The visible volumes are intersected with the assessment volume to allow the proportion of the assessment volume that is visible to the virtual driver to be calculated

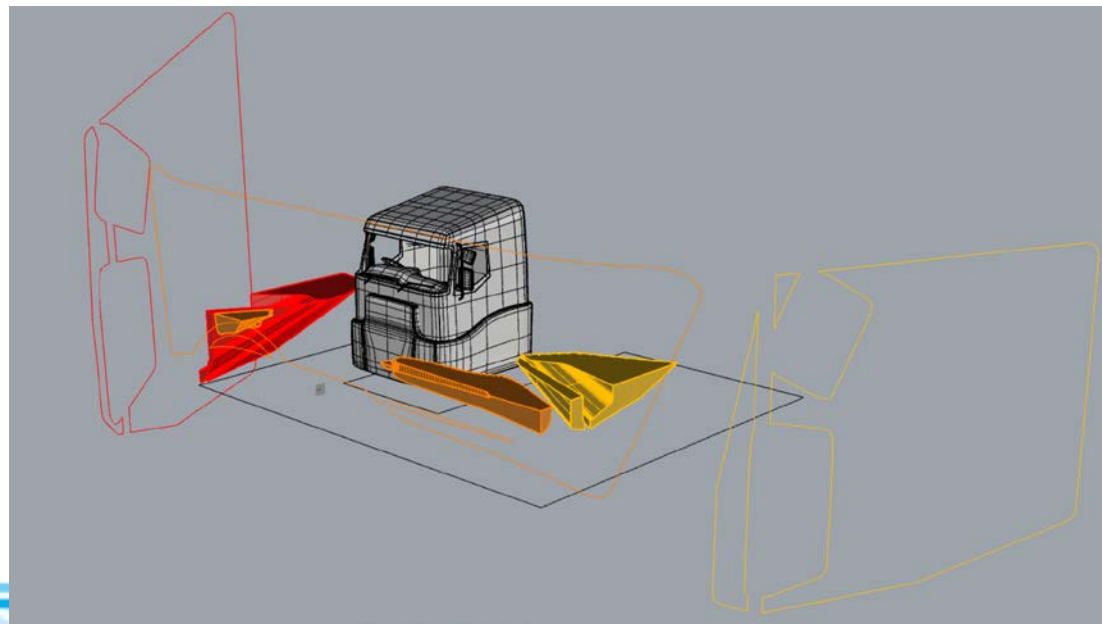
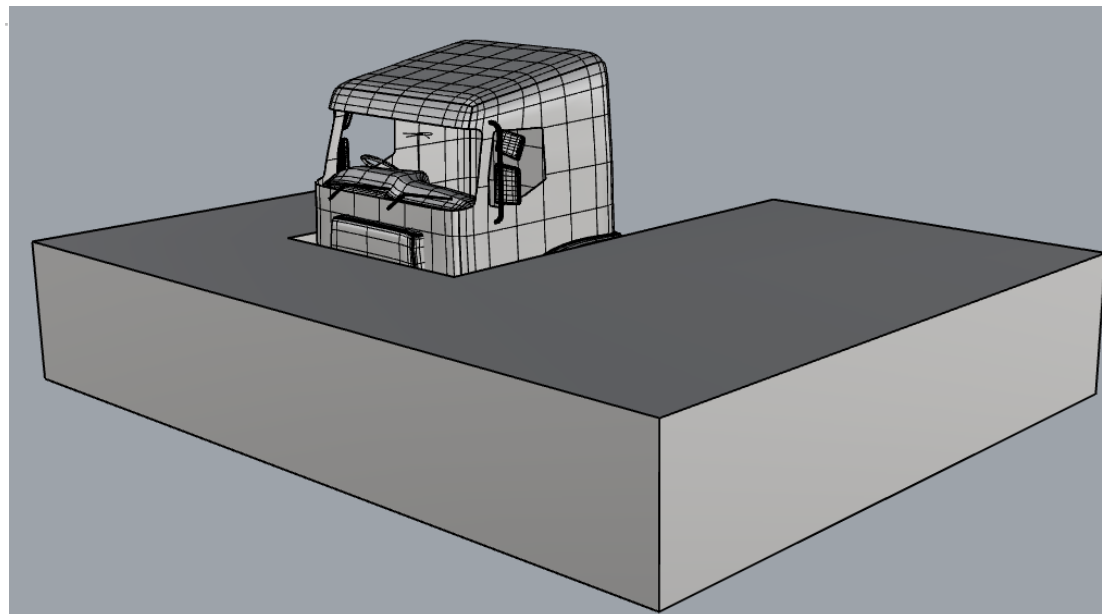

The use of VRU simulations to validate the volumetric results

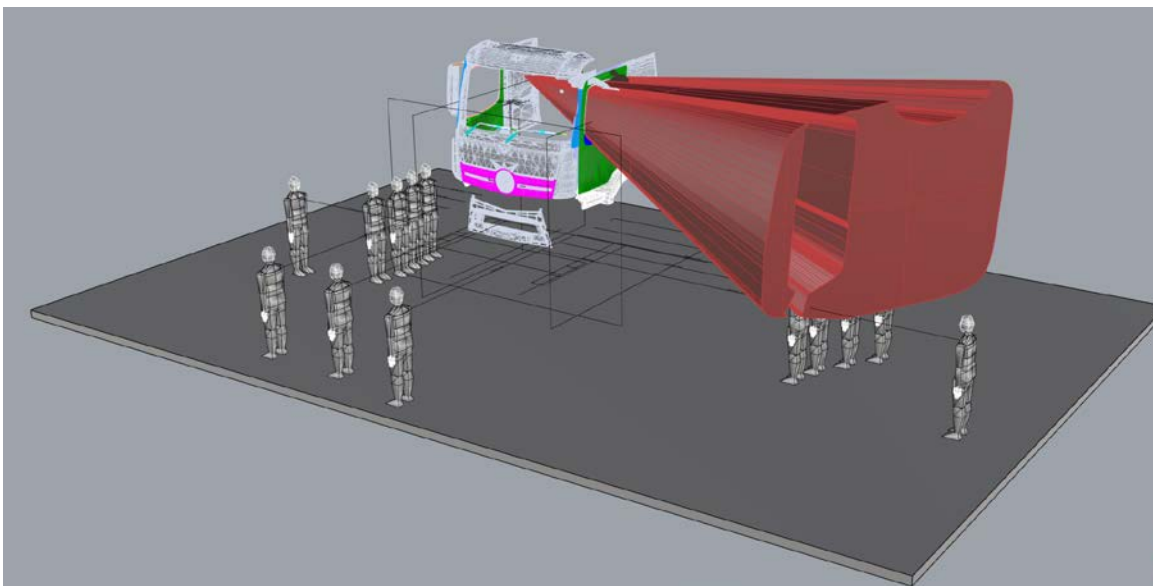
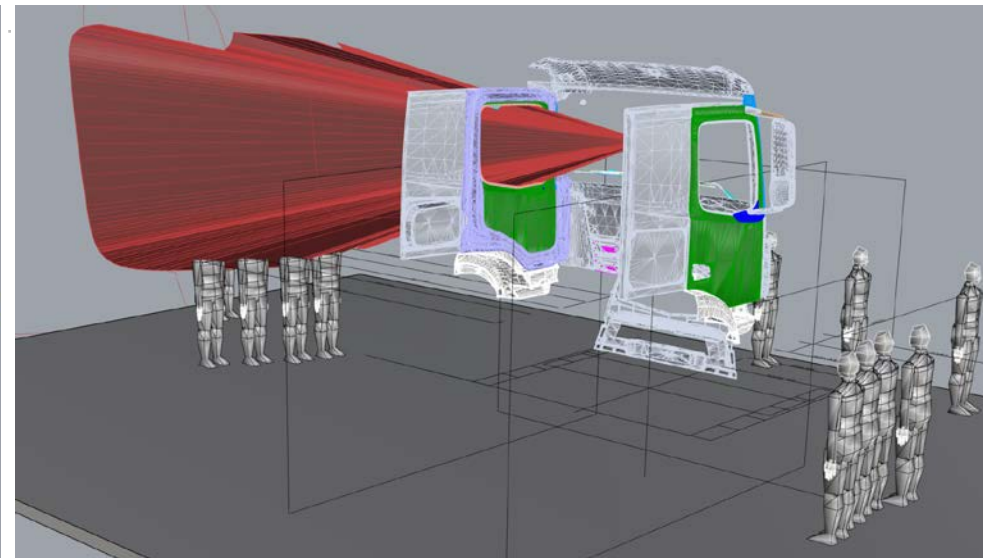
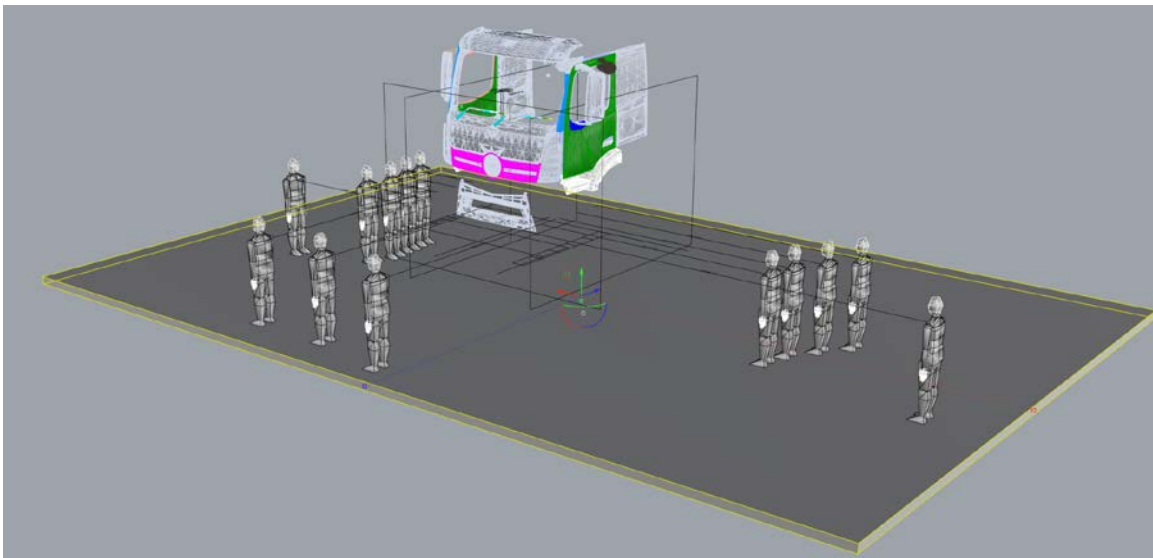

- Top Left – The VRUs are shown around the truck
- Bottom left- the visible volume through the left window is shown
- Top right – The head and shoulders of the VRU intersect with the visible volume at the locations shown and the distances of all VRUs from the side of the truck are measured

The results: Volume plotted against VRU distance

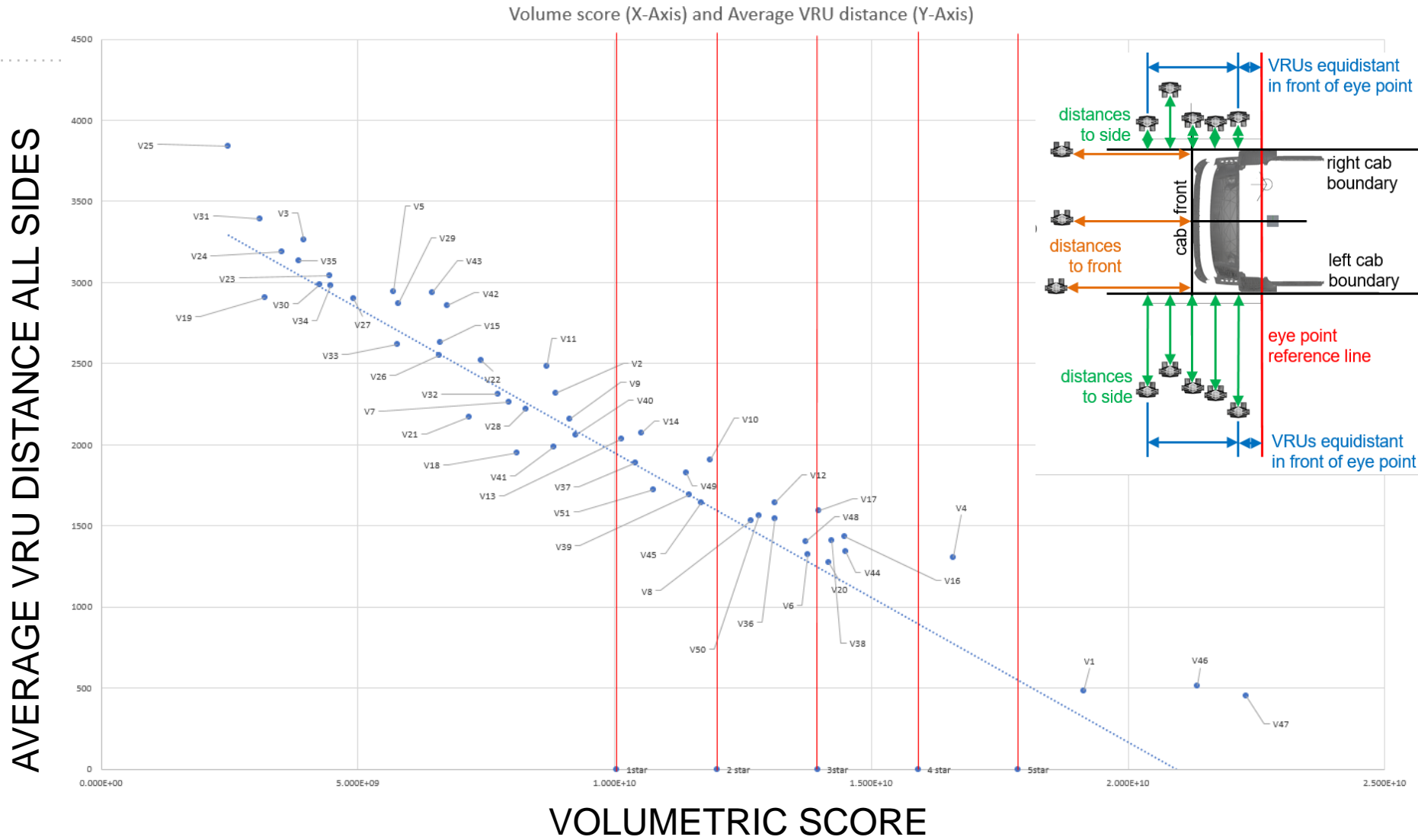

0.97 correlation between volume scores and VRU scores : 0.5 is strong, 1 is perfect

Real world tests that are proposed for prototyping

- V1 – using the seat to support an eye rig that can support three small wireless cameras
- V2 – Using a rig that fixes to the windows and is then remotely aligned to the correct eye point position

Real world tests that are proposed for prototyping

V1 – using the seat to support an eye rig that can support three small wireless cameras

Rig V1

- Uses three wireless cameras to allow views to be remotely captured outside of the cab
- Uses a weighted form that is supported by the seat to correctly locate the front camera location
- Uses the AHP calculations in SAE 1516
 - The SGRP height defines the foot angle for interaction with the A pedal

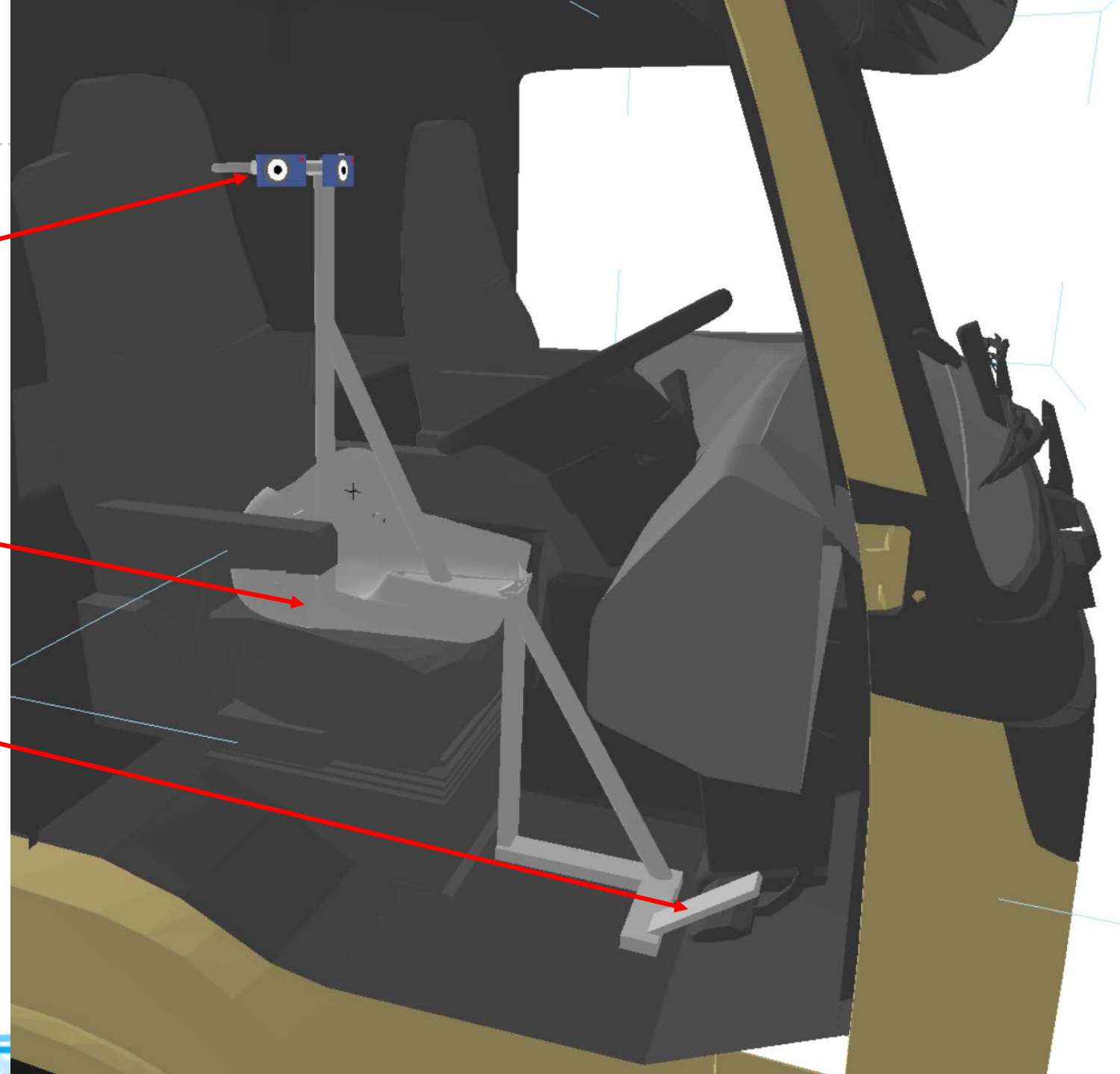

Real world tests that are proposed for prototyping

V2 – Using a rig that fixes to the windows and is then remotely aligned to the correct eye point position

Rig V2

- Uses simple templates to located the rig using suckers on each window
- Three camera rig can then be positioned correctly in the cab to define the DVS eye points using two possible techniques



Rig V2

- Simple 2D template used to align the camera rig position through the window



- Motorised version which automates the process using triangulation of photogrammetry markers

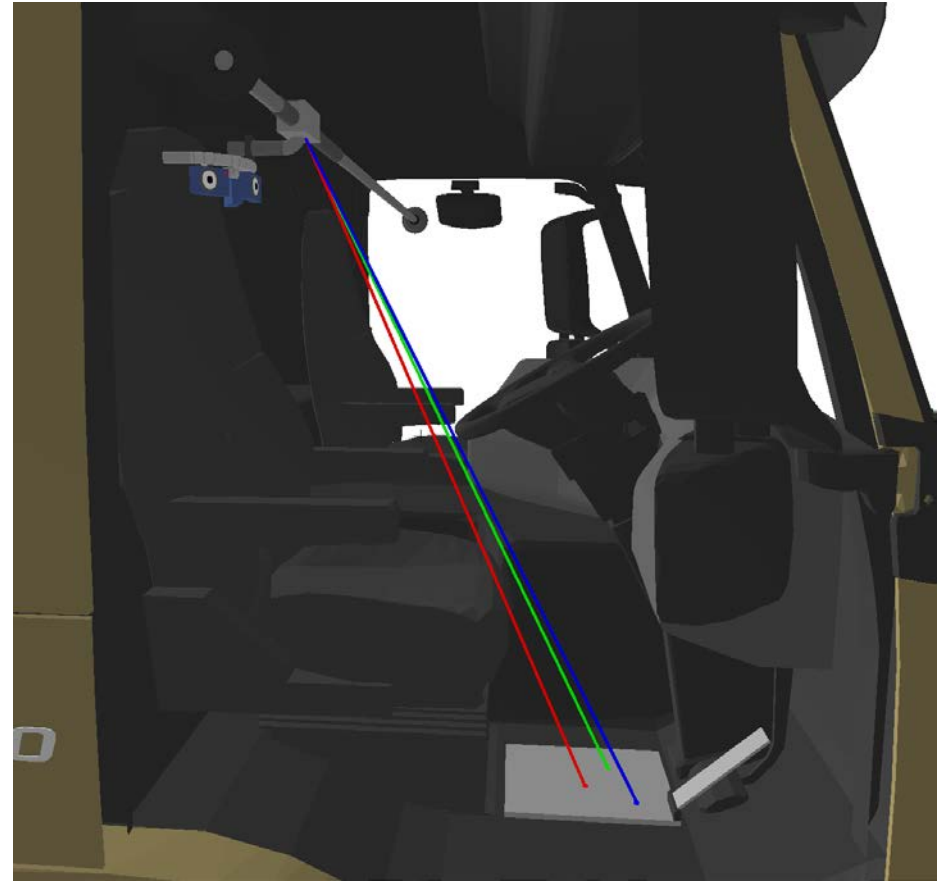

VRU simulations

- In the virtual process we use a simple VRU simulation with the height of a 5th percentile Italian female and ensured that the head and shoulders are visible to the driver in testing
- The 'real world' test would use the a simplified representation of this human simulation where the red section should be seen by the driver, using the same head and shoulder dimension.



VRU simulations

- Each poll would be setup in a specific location and moved along predefined lines until the red section is visible in the camera view

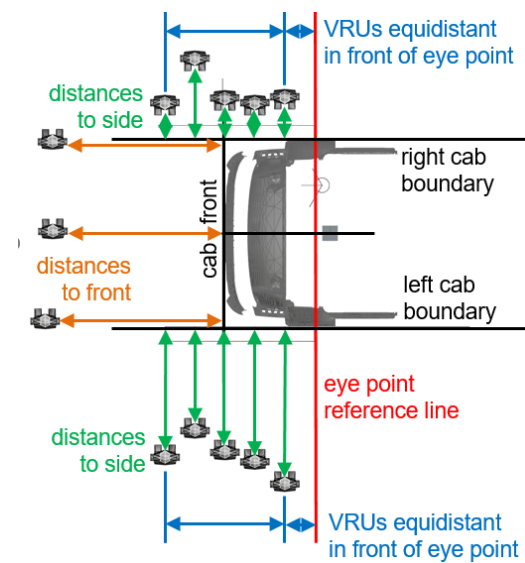
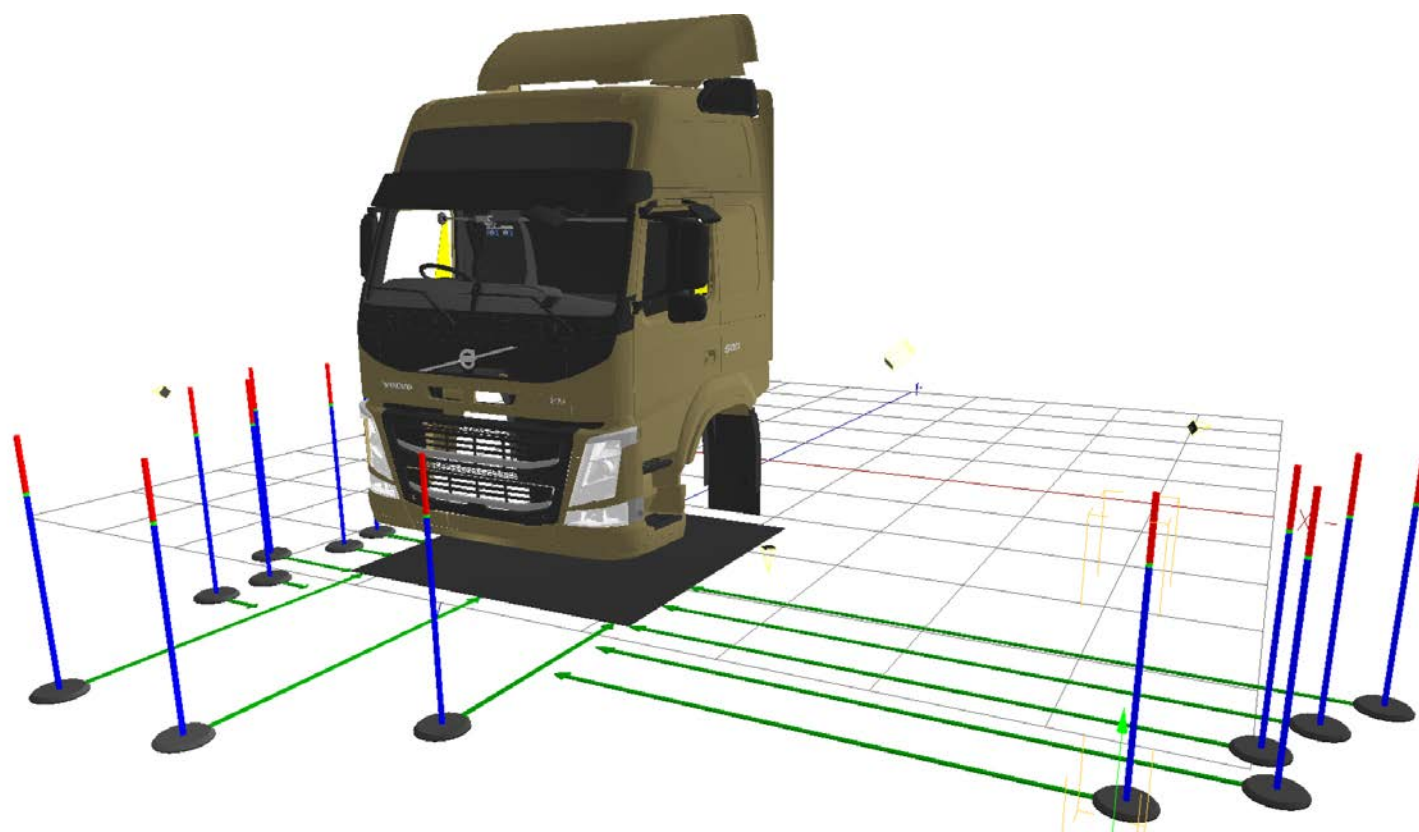

Lateral pole positions defined as above

VRU simulations

- Simulated camera views which would be used to align the poles in the correct position

Left camera view

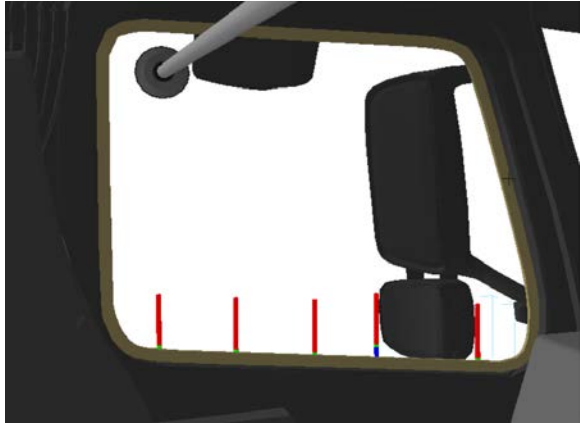

Front camera view

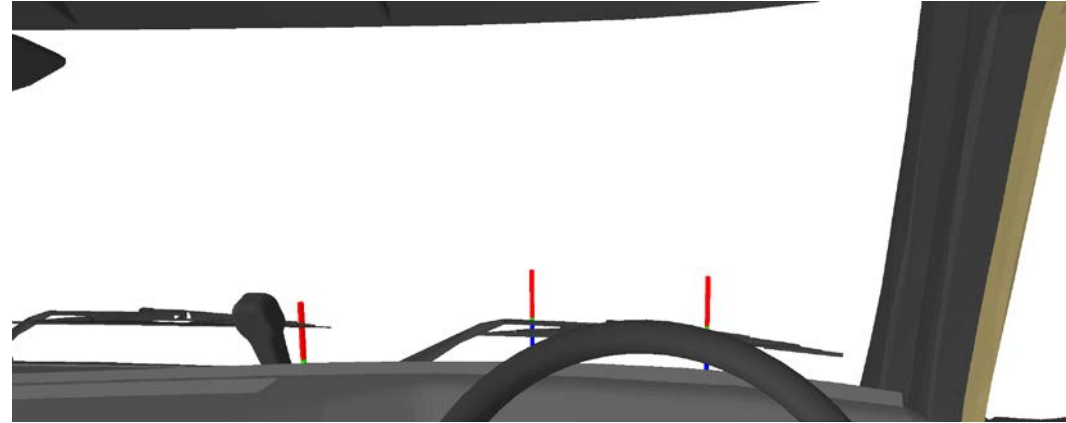

Right camera view

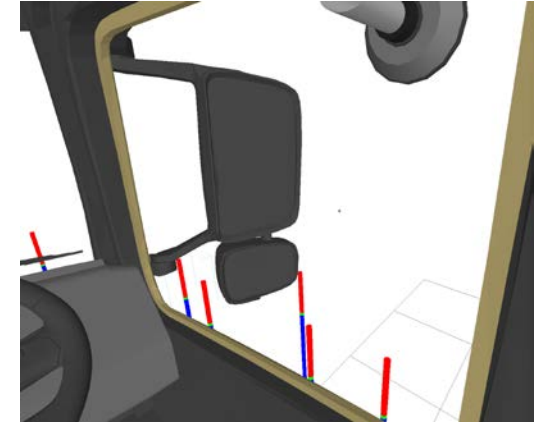

The results: Volume plotted against VRU distance

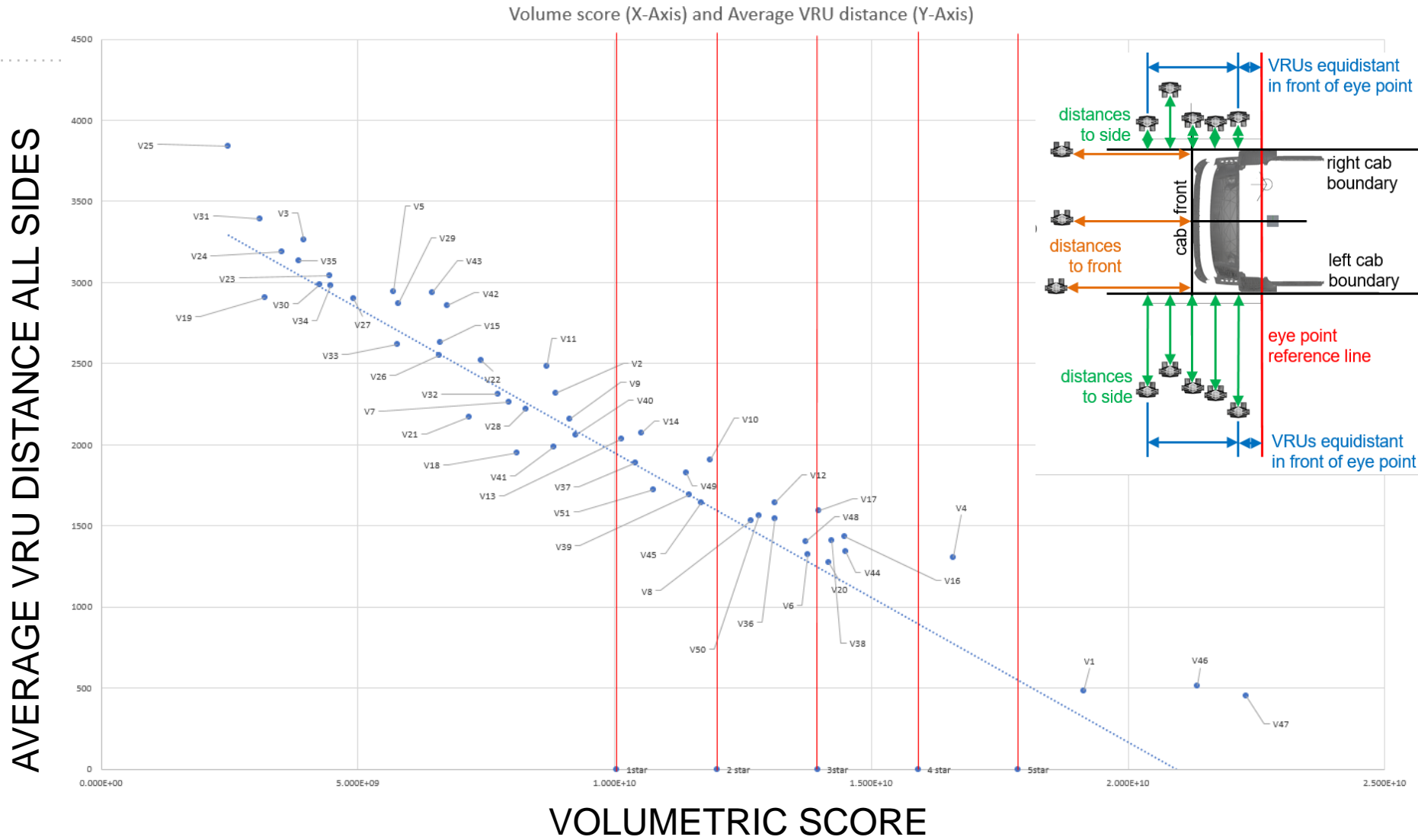

0.97 correlation between volume scores and VRU scores : 0.5 is strong, 1 is perfect

The results: Volume plotted against VRU distance

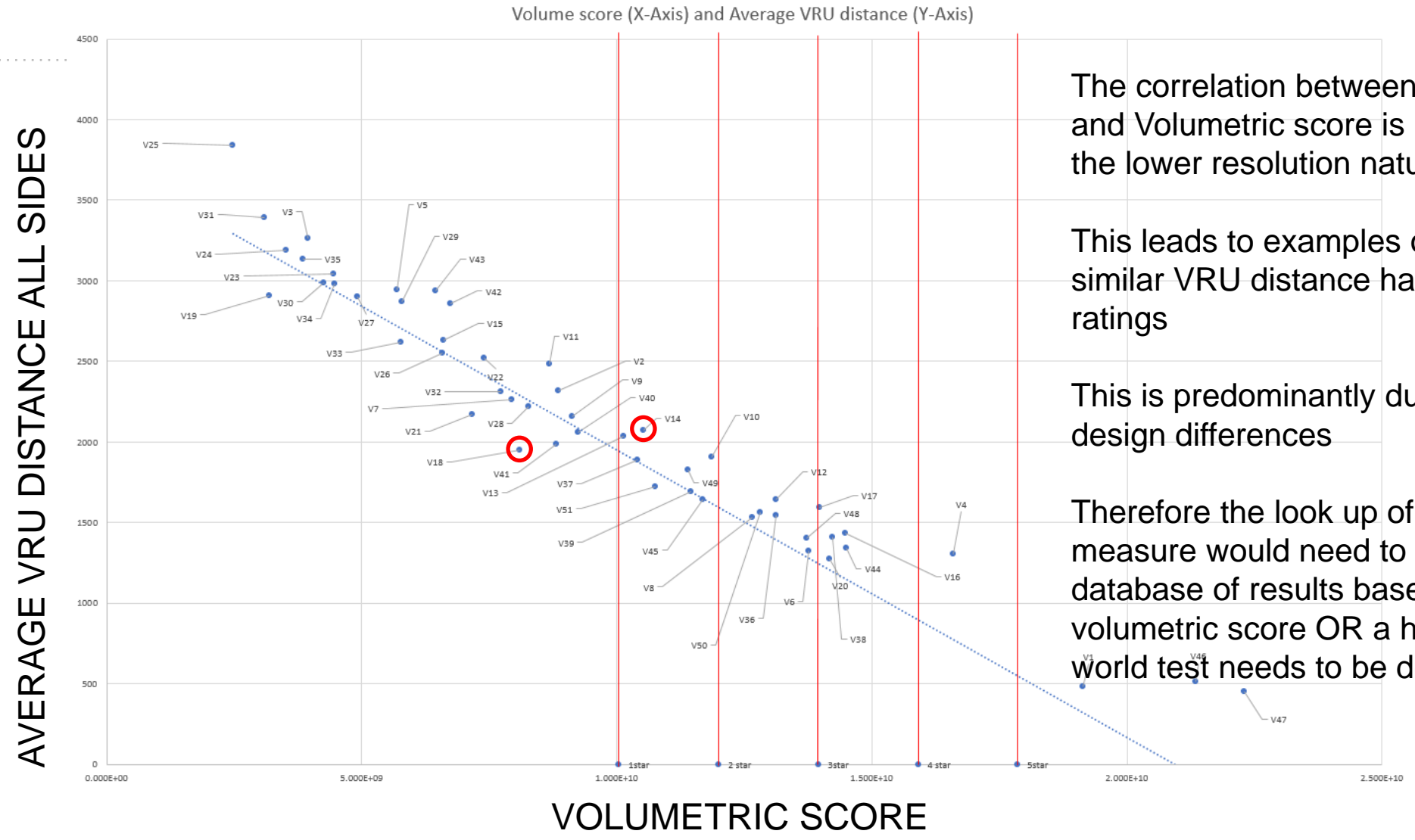

The correlation between Av. VRU distance and Volumetric score is not perfect, due to the lower resolution nature of the VRU test

This leads to examples of vehicles with a similar VRU distance having different star ratings

This is predominantly due to mirror housing design differences

Therefore the look up of a 'real world' VRU measure would need to be to a predefined database of results based upon the volumetric score OR a higher resolution real world test needs to be defined and tested

0.97 correlation between volume scores and VRU scores : 0.5 is strong, 1 is perfect

Potential option for differentiation between Urban/Long Haul/Construction vehicles



Differentiated approach

- The current proposal is that all vehicles should be able to reach the 1 star level as presented at the previous meeting
- However if contracting parties demonstrate that this has an unduly punitive effect a differentiated approach may be required i.e. different rules for Long Haul/Heavy construction vehicles when compared to urban distribution vehicles
- One way in which the Long Haul/Heavy construction vehicles can be differentiated from urban distribution vehicles is simply by vehicle floor height (AHP) above the ground plane
- Previous work has (LDS/TfL 2015*) showed a good correlation between driver's height above the ground and the direct vision performance with higher vehicles having worse performance
- The kinds of vehicles that we want to exclude from city centres for safety reasons are generally the tallest cab, and they are tall due to engine specification (long haul), or vehicle suspension and tyre configuration (heavy construction), or a combination of the two

*<https://dspace.lboro.ac.uk/2134/21028>

Differentiated approach – Urban/Long Haul/Heavy Construction – an initial proposal

- So, to allow a differentiated approach (e.g. longer lead times for direct vision improvements for Long Haul cabs) any vehicle with a floor height above a certain value could be defined as Long Haul/Heavy Construction at the point of registration, by the manufacturer
- Taller cabs that are generally used as Long Haul can also be used as Tippers and other heavy construction vehicles.
- The graph shows the highest possible AHP height for a selection of trucks in the sample
- The vehicles with AHP height above 1500mm are potentially predominately used for Long Haul/Heavy Construction.
- All of the vehicles with an AHP above 1500mm in the graph, are currently zero star
- **We need to explore the detail of this proposal using the data that we have for the full range of vehicles in the sample.**

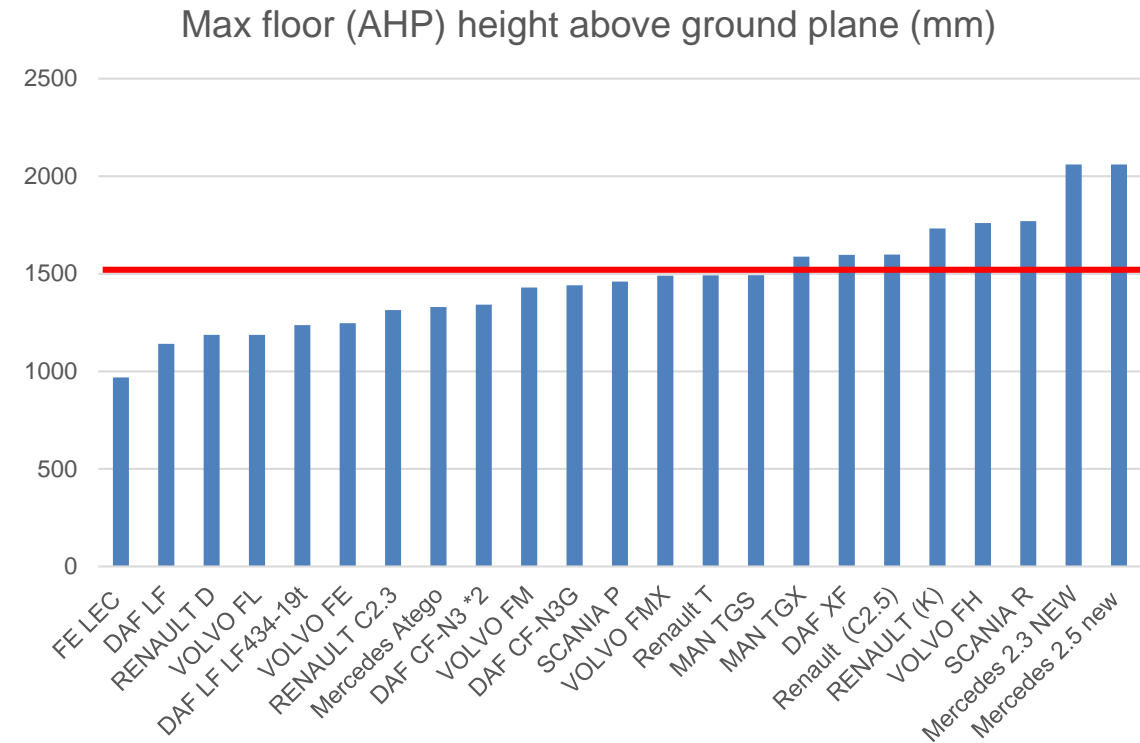

Project information

Thank you for your attention, are there any questions?

Dr Steve Summerskill (s.j.summerskill2@lboro.ac.uk)

Dr Russell Marshall (r.marshall@lboro.ac.uk)

Dr Abby Paterson

Anthony Eland

Dr Jim Lenard

Design Ergonomics Group

Loughborough Design School

Loughborough University