



Fire detection & fire alarm systems in heavy duty vehicles

WP1 – Survey of fire detection in vehicles

Ola Willstrand, Peter Karlsson, Jonas Brandt

SP Technical Research Institute of Sweden

FFI

FORDONSSTRATEGISK
FORSKNING OCH INNOVATION

This project was partly funded by FFI

SP Fire Research

SP Report 2015:68

Fire detection & fire alarm systems in heavy duty vehicles

WP1 – Survey of fire detection in vehicles

Ola Willstrand, Peter Karlsson, Jonas Brandt

Abstract

The work presented in this report is part of a larger project about fire detection and fire alarm systems in heavy duty vehicles. The work presented here covers fire detection technologies, standards and guidelines and research in the field. The purpose of this work is mainly to provide background information for the other work packages in the project. An understanding of different types of detection technologies; how the systems function and what their advantages and disadvantages are, is provided. An extensive summary of all relevant standards and guidelines, including those used in adjacent fields like the rail, aviation and marine industry, provides necessary information to the overall goal of defining an international test standard for fire detection in heavy duty vehicles. At last a short overview of past and ongoing research regarding fire detection in vehicles is presented.

Key words: fire detection, detector technologies, vehicles, standards, guidelines

SP Sveriges Tekniska Forskningsinstitut
SP Technical Research Institute of Sweden

SP Report 2015:68
ISBN 978-91-88001-96-2
ISSN 0284-5172
Borås 2015

Contents

Abstract	3
Preface	6
Summary	7
1 Introduction	8
2 Fire signatures	9
3 Fire detectors	11
3.1 Heat detection	11
3.1.1 Point heat detectors	12
3.1.2 Line heat detectors (LHD)	12
3.2 Gas detection	13
3.2.1 Catalytic gas detectors	13
3.2.2 Electrochemical gas detectors	14
3.2.3 IR gas detectors	14
3.3 Smoke detection	14
3.3.1 Ionisation smoke detectors	15
3.3.2 Light scattering optical smoke detectors	15
3.3.3 Light obscuration optical smoke detectors	16
3.3.4 Aspirating smoke detectors	16
3.4 Flame detection	17
3.4.1 IR detectors	17
3.4.2 UV detectors	18
3.4.3 UV/IR-detectors	18
3.5 Combined/multi detection	18
3.6 False alarms	18
4 Alarm systems	20
4.1 Conventional and addressable systems	20
4.2 Redundant systems	20
5 Standards and Guidelines	22
5.1 Buildings	22
5.1.1 EN 54 Fire detection and fire alarm systems	22
5.1.2 EN 14604 Smoke alarm devices	29
5.1.3 ISO 7240 Fire detection and alarm systems	29
5.1.4 NFPA 72 National fire alarm and signaling code	32
5.1.5 FM Approvals	33
5.1.6 Underwriters Laboratories	34
5.2 Trains	37
5.2.1 EN 45545 Fire protection on railway vehicles	37
5.2.2 prEN 16334 Railway applications – Passenger Alarm System – System requirements	39
5.2.3 EN 50553 Railway applications – Requirements for running capability in case of fire on board of rolling stock	39
5.2.4 ARGE Guideline	40
5.3 Aircrafts	42
5.3.1 ICAO – the International Civil Aviation Organization	42
5.3.2 FAA – Federal Aviation Administration	42
5.3.3 Joint Aviation Authorities (JAA)	44

5.3.4	European Aviation Safety Agency (EASA)	45
5.4	Ships	45
5.4.1	International Convention for the Safety of Life at Sea (SOLAS)	45
5.4.2	International Code for Fire Safety System (FSS Code)	45
5.4.3	International Maritime Organization (IMO)	47
5.5	Military applications	47
5.5.1	STANAG 4317	47
5.6	Road vehicles and other transportable equipment	48
5.6.1	FM 5970 Heavy Duty Mobile Equipment Protection Systems	48
5.6.2	AS 5062 Fire protection for mobile and transportable equipment	49
5.6.3	SBF – Swedish Fire Protection Association	49
5.6.4	ADR-S	51
6	Research and studies	52
7	Conclusions	53
	References	55
	Appendix A: All chapters in EN 54	58
	Appendix B: All chapters in ISO 7240	59
	Appendix C: Interesting chapters in CFR - Title 14 - Part 25	60

Preface

This work was partly funded by the FFI program of the Swedish Governmental Agency for Innovation Systems, VINNOVA. Also all support from co-partners in the project is gratefully acknowledged.

Summary

This report summarises the results from the first work package (WP1) of the project “Fire detection & fire alarm systems in heavy duty vehicles – research and development of international standard and guidelines”. The purpose of WP1 is to provide a description of available detection technologies, a summary of relevant standards and guidelines and an overview of up-to-date research in the field fire detection in vehicles.

The first part of this report (chapter 2-4) gives a general understanding of how a fire can be detected, available technologies and how an alarm system may be structured. The main four fire signatures that are used for detection are gas, smoke, flames and heat. Gas detectors may be constructed to detect incipient gases or gases that are products of the combustion. Smoke detectors mainly react on the soot produced in case of incomplete combustion. Gas and smoke detectors may also be part of a sampling system, meaning that air is sampled and transported to the place where the detector/sensor is positioned. Flame detectors react on the radiation from the flames and may be sensitive to infrared or ultraviolet radiation, or both. At last, heat detectors are sensitive to the heat generated in the combustion process.

The most comprehensive part of this report (chapter 5) summarises the standards and guidelines that are most relevant for fire detection in vehicles. There are no international standard for fire detection in vehicles today, which is the aim of the project which this report is a part of. Instead fire detection standards applicable for other areas are examined. There are general approval standards for fire detection, like EN 54 for example. These are comprehensive and useful standards, however mainly applicable for buildings. In EN 54 it is explicitly stated that it is only valid for detectors used in buildings, but can be used as a guideline for other applications. Regulations and guidelines used in adjacent fields like the rail, aviation and marine industry are reviewed. Also a standard used in the military field is examined. In the end of this chapter some national standards used for vehicle application are presented, but the content in these standards dealing with fire detection is limited, or focused on risk assessment. The conclusion of this part dealing with standards and guidelines is that there are needs for a new international standard for fire detection in vehicles and that the general approval standards for building applications are a good start, but need modifications and supplementary tests.

The last part of this report (chapter 6) gives an overview of reported and ongoing research in the field: fire detection in vehicles. This chapter is very short due to that not much has been conducted regarding this area. Principally it is SP Fire Research and some organisations in the US that are currently doing research on this, but the published material is very limited.

1 Introduction

In June 2013 a project entitled “Fire detection & fire alarm systems in heavy duty vehicles – research and development of international standard and guidelines” was launched. The project is financed by the Swedish FFI-program (Strategic Vehicle Research and Innovation) which is a partnership between the Swedish Governmental Agency for Innovation Systems (VINNOVA) and the automotive industry. The aim of the project is to develop a new international test method for fire detection systems in the engine compartment of buses and other heavy duty vehicles. All work packages of the project are listed below:

WP1: Survey of fire detection in vehicles

WP2: Factors influencing detector performance in vehicles

WP3: Fire causes and risk analysis for heavy duty vehicles

WP4: Fire detection systems for engine compartments

WP5: Fire detection in bus and coach toilet compartments and driver sleeping compartments

WP6: Development of international standard

WP1-WP4 are mainly focused on producing background material for the overall goal of defining an international test standard for fire detection in engine compartments, WP6. The first work package, WP1, documented in this report, covers the basics in detector technology, what detectors are used in other transportation industries, existing standards and guidelines as well as what research has been conducted up until this date.

The purpose of WP1 is to provide background information for the other work packages and to provide a picture of the fire detection technology which is available at present, how the systems function and what their advantages and disadvantages are. In order to define a relevant test standard in WP6 the standards and guidelines for detection systems in buildings and other industries should be reviewed and learned from. Also trends in research and development should be analysed and the results should provide information to make sure the test standard will be technology neutral and therefore open to new detection systems in a foreseeable future.

The report consists of three major parts: a description of available fire detection and alarm technologies, a summary of relevant standards and guidelines for detection systems and a summary of past and ongoing research regarding fire detection in vehicles.

2 Fire signatures

In order to detect a fire at least one fire product needs to be identified. Fire detection systems are designed to be sensitive towards different fire signatures; smoke, heat, flames or gas. Different fires produce these characteristics differently and they can be divided into two main groups; flaming fires and smouldering fires. Flaming fires occur when the combustion of fuels takes place in the gas phase and therefore all fuels must first transform into the gas phase through pyrolysis. Smouldering fires on the other hand occur when a porous fuel creates solid carbonaceous compounds during pyrolysis and does not shrink away when heated. The combustion occurs in a reaction of the surface in a solid phase and this usually means that the fire does not produce any flames. Typically materials that can create smouldering fires are paper, sawdust, cloths, leather, shipboard and expanded plastics. Smouldering fires can develop into flaming fires if the ventilation is improved and, vice versa, flaming fires may become smouldering if the ventilation is decreased by too much [1].

Fire detection systems need to be able to identify at least one of the products which constitute the fire signatures of the different fire types. Typically the detectors are targeting smoke, heat and flames. Gas detectors are also available, although they are mainly used for the detection of potentially toxic gases or explosive atmospheres created from combustible gases. In addition to identifying one of the fire products the detectors also need to sense enough smoke, heat, flames or gas to ensure that it really is a fire product and not a false alarm.

Smoke consists of soot particles and the cleaner the combustion is, the less smoke is produced. Smoke can be identified visually and is often the most common way of identifying a fire. Heat can both be noticeable by a heightened temperature, but also by the rate of the temperature rise. Flames produce light in a broad wavelength range and consists of ultraviolet (UV) light, visual light and infrared (IR) light. Depending on the light of the surrounding environment, these can be more or less easy to discover and discriminate from the background. When a fire occurs there will also be a production of gases. The most common gases for fire detection are CO and CO₂ but there could also be NO_x and other gases. Most of them are highly toxic. They are normally invisible and therefore very hard to discover for a human, but sometimes the sense of smell can tell if there is gas from a fire in the air. With the right technologies all fire signatures can be measured and, with the correct boundary conditions based on knowledge of the normal conditions, the fire can be detected.

Smouldering and flaming fires typically behave like in **Fel! Hittar inte referenskölla..** Until the heat start rising, the fire will be limited, its rate of spread will be small and if detected the damages from it should be controllable unless e.g. a smouldering fire has gone on for a long period of time, extending it to cover a large area. It is therefore important to detect a fire early, before the heat generation has become too high.

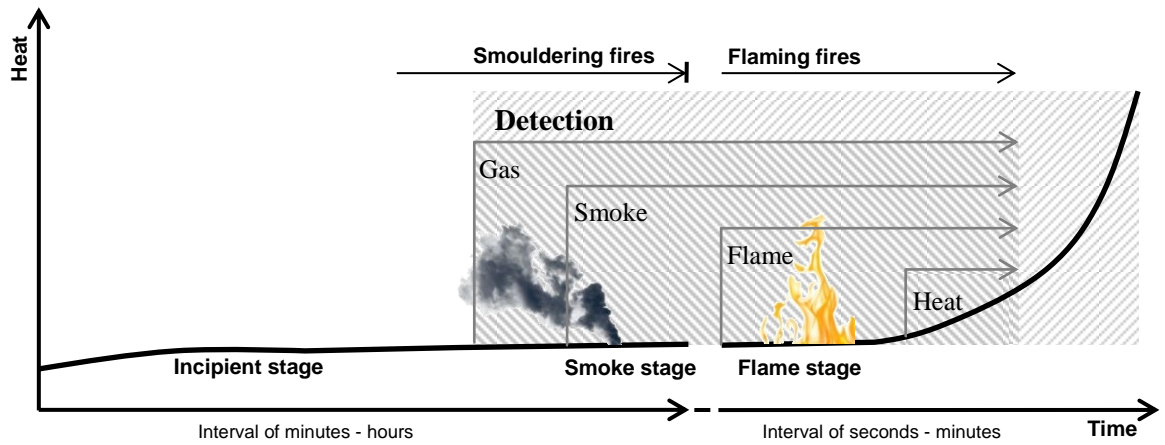

Figure 1. The figure shows common detection methods for different stages of fires and different types of fires. Slowly developing fires may stay in the incipient stage and smoke stage for hours. In these stages gas is the first fire product which can be detected, smoke is the other one. Smouldering fires can usually only be detected from either of those products. Flaming fires on the other hand first produce flames and then a lot of heat and they grow fast. For flaming fires optical flame detectors and heat detectors are suitable to use, but they can also be detected by gas detectors and smoke detectors.

3 Fire detectors

Detectors are designed and installed to protect a space mainly by four different approaches, see Figure 2;

- Point detection;
 - Each detector senses information in a certain spot;
- Line detection;
 - The detection system senses information between two spots or along a hose/wire;
- Volume detection;
 - The detection system senses information available in a volume; and
- Aspirating detection
 - The detection system extracts air in one or several spots and analyses it at a different location.

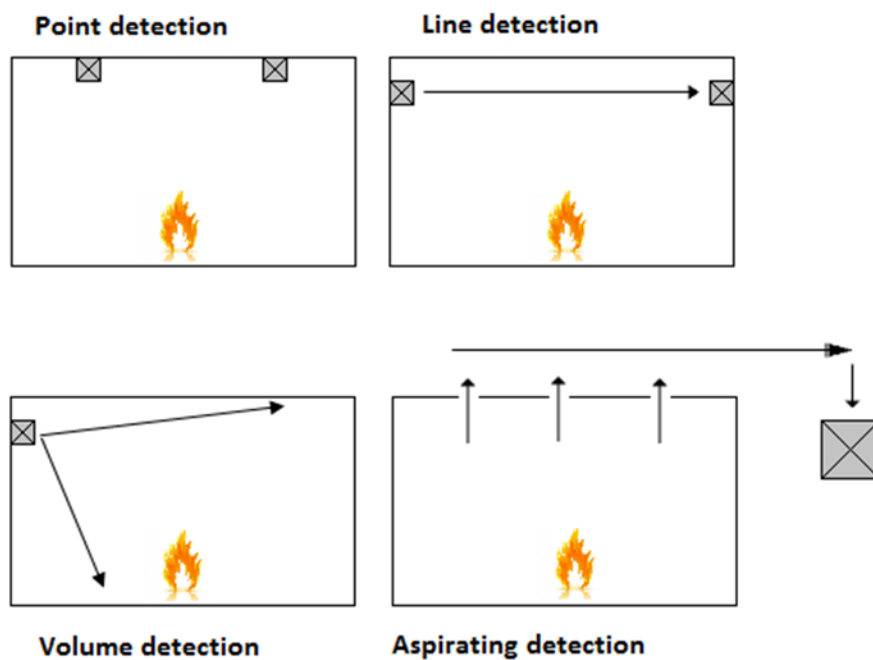

Figure 2. Different types of operating procedures of fire detection.

The next sub-chapters describe the most common detection technologies used today in all kinds of applications. However, there are also others that may be used to detect a fire but are not mentioned or described further in this chapter, including e.g. video detection, sound detection and pressure detection (explosion detection).

3.1 Heat detection

Heat detection is the most common way today to detect fires in the engine compartment of heavy vehicles. Most heat detection systems are simple, cheap, robust, and easy to maintain. However, as seen in **Fel! Hittar inte referenskölla.**, heat as a fire signature is not the fastest way to detect a fire. In an engine compartment there will also be a high operation temperature and the alarm level must be higher than that if rate of temperature rise is not used. Below some different principles of heat detection are described.

3.1.1 Point heat detectors

In point heat detectors there are one or more thermal elements, which are heated when hot smoke are passing the detector. These elements have a mass and a specific heat capacity, which results in a thermal inertia when heated. Thermal inertia controls how fast the detector reaches a specific temperature and depending on the material used it will take different time to reach the alarm level, i.e. it affects the response time [1]. The response time can be expressed as a response time index (RTI), which is used for sprinklers, where a low value indicates a fast response. RTI is measured by means of plunging the detector/sprinkler into a hot air stream. The elapsed time to activation together with air velocity, air temperature, ambient temperature, and temperature rating of the detector gives the RTI-value.

Heat detectors are normally divided into two main classifications of operation:

- *Fixed temperature*, which will activate once the thermal element has reached a specific temperature.
- *Temperature Rate of Rise (RoR)*, which will activate at a certain temperature increase rate. Most times this procedure will detect a fire faster than fixed temperature sensors.

There are also detectors that operate using a combination of fixed temperature and temperature rate of rise. This combination has the advantages of both detectors and has proven to be a more reliable detector [1]. For more advantages/disadvantages see Table 1.

Table 1. Advantages and disadvantages of heat detectors.

Advantages	Disadvantages
Insensitive to disturbances from e.g. dust	Long activation time in large areas
Low false alarm rate	Hard to detect smouldering fires due to the low temperature

3.1.2 Line heat detectors (LHD)

These detectors use a hose/wire/cable to detect heat anywhere along its length. There are many types that can be used; one example is a gas filled tube that reacts to the heat during a fire. The built up pressure, due to the fire making the gas expand, activates the detector. This solution is widely used in the aviation industry and goes under the name Advanced Pneumatic Detector (APD). Widely used are also LHD using low resistance twisted wires, insulated from each other by thermal polymers that are set to melt at a fixed temperature (see Figure 3). The melting of the polymers causes the wires to connect, short circuit, and activate the detector. To determine where the fire is located a distance-locating module can be attached [2].

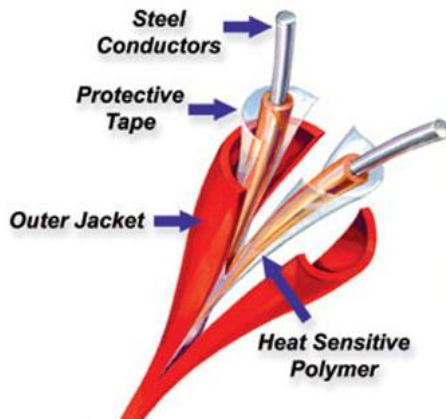

Figure 3. Example of how a LHD cable is constructed [3].

Newer technologies have also emerged on the market. One type uses fibre optics, consists of glass fibres and a laser that sends light through the fibre. In the event of fire and/or temperature rise small changes in the fibres cause a change in its refractive properties. This change is noticed by a light receiver that activates the detector. Fibre optics can be used to detect temperature changes along a loop up to several kilometres long. The exact location of the temperature increase can also be located with good accuracy [1].

3.2 Gas detection

Gas detectors are mainly used to sense the presence of concentrations of combustible gases before a fire or explosion occurs. However they can also be used to detect typical substances produced from a fire such as carbon monoxides and hydrocarbons. There are different principles and technologies available for gas detection with different advantages and disadvantages. Below are catalytic, electrochemical, and IR gas detectors presented. Other detectors e.g. use semiconductor sensors, thermal conductivity sensors or absorbent filter tape.

One interesting principle of gas detection is called “electronic nose”, and it uses several semiconductor sensors to “smell” different gases. The relative concentrations between the different gases give patterns such that the detector recognises if the “smell” is from combustible gases, an actual fire or from a false alarm source. This technology is used today in e.g. mines, tunnels, and other harsh environments and might be relevant also for engine compartments of vehicles. [4]

3.2.1 Catalytic gas detectors

Catalytic gas detectors consist of two coils that are connected as an electrical circuit. The coils are also embedded within a ceramic pellet. These pellets are heated by passing a current through the underlying coil. One of these pellets also has a surface of a noble metal which also will be heated by the current and acts like a catalyst for oxidation of combustible gases on the surface. This will produce heat that will change the resistance in the circuit. The other pellet, which does not have a surface of a noble metal, will work as a reference to remove the effects of environmental factors other than the presence of combustible gases. [5]

Within a given concentration of gases, which gives a given difference in resistance between the two coils, the detector will be activated. The catalytic gas detector is inexpensive and can detect a lot of different combustible gases. The disadvantage of the detector is that it will be consumed after some time, it will easily get contaminated and lose its ability for detection. It must also be calibrated relatively frequently. [1]

Advantages and disadvantages for the catalytic gas detector has been summarised in Table 2.

Table 2. Advantages and disadvantages for catalytic gas detectors. [1]

Advantages	Disadvantages
Inexpensive	Needs frequent calibration
Can detect a lot of different combustible gases	With time it will be consumed
	Not suited to detect fires (since combustible gases is combusted by the fire)

3.2.2 Electrochemical gas detectors

The electrochemical gas detector consists of electrodes that operate in an electrolyte. When a specified gas, for example unburned hydrocarbons, come in contact with the electrolyte a reaction will occur. This reaction will create an electric current, by the electrons that are generated by the reaction, which is proportional to the concentration of the gas. Electrochemical gas detectors are very sensitive and can, if the conditions are good, detect a gas with only a few ppm (parts per million). The detector will get contaminated very easy and will be consumed with time. [1]

3.2.3 IR gas detectors

The IR gas detector could be of point or of linear type and is in its principle of operation similar to the light obscuration optical smoke detector (section 3.3.3 in this report). The IR gas detector can detect e.g. hydrocarbons or carbon dioxide. The detector is sending IR light to a receiver. When the gases reach the detector it will absorb some of the IR-radiation. The intensity of the radiation will thereby be decreased when reaching the receiver which will then activate the detector. [1]

Advantages and disadvantages for the IR gas detector has been summarised in Table 3.

Table 3. Advantages and disadvantages for IR gas detectors.

Advantages	Disadvantages
Can detect a lot of different kind of hydrocarbons	Expensive
The detector is robust compared to the other gas detectors	

3.3 Smoke detection

Smoke detectors are a collective name and can be divided into subgroups in respect of function as seen below.

- Ionisation smoke detectors
- Light scattering optical smoke detectors
- Light obscuration optical smoke detectors

These are designed to detect the particles or aerosols created by the combustion. It is by far the most used detector (although not in engine compartments) and has shown good performance in clean areas in the absence of dust [1].

Aspirating smoke detectors often use the light scattering principle but can use any of the three technologies listed above. However, these detectors have their own advantages and disadvantages and are covered in a separate section below.

3.3.1 Ionisation smoke detectors

Ionization smoke detectors function as closed circuits where the detector transmits α -particles, which ionise molecules in the air into positive ions and negative electrons. These are attracted to charged metal plates inside the detector and give rise to a weak current in the circuit. When smoke passes through the detector, the positive ions and negative electrons attach to the smoke particles and due to the mass of the particles they will simply pass by the metal plates without attaching to them. This will cause a decrease of voltage in the circuit, and the detector will activate at a fixed value of voltage decrease.

Ionisation smoke detectors are most sensitive for a high concentration of particles created by an open flame. For more advantages/disadvantages see Table 4.

Table 4. Advantages and disadvantages of ionisation smoke detectors.

Advantages	Disadvantages
Very sensitive to small smoke particles created from e.g. flaming fires	High false alarm rate due to cooking and/or hot steam.
Relatively cheap	Radioactive waste material

3.3.2 Light scattering optical smoke detectors

This detector type consists of a light source and a photocell positioned at an angle to each other. In normal conditions the transmitted light passes into a “light catcher” which prevents the reflection of light onto the receiver. In the event of fire, the smoke in the detector scatters the light onto the photocell and at a specific threshold value of light intensity the detector activates (see Figure 4).

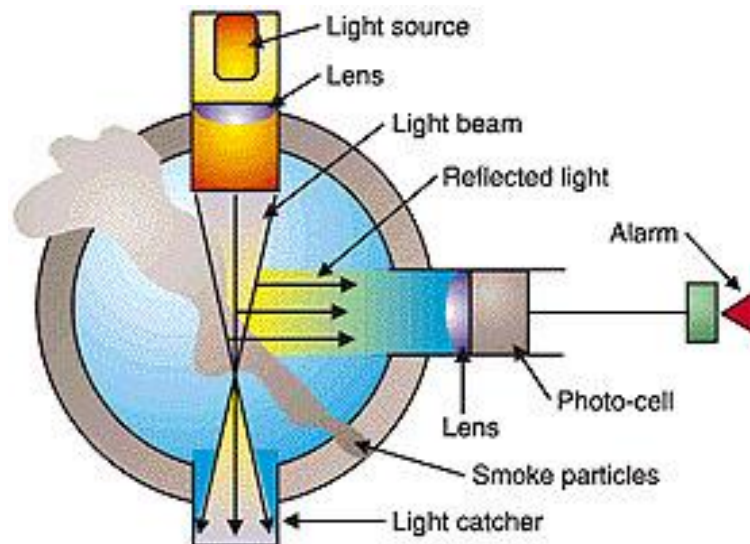

Figure 4. Example of how an optical smoke detector works [6].

Light scattering smoke detectors are more sensitive to large particles formed by smouldering fires. They function best with brighter fumes since they reflect light better than darker ones. Advantages and disadvantages for this detector type are summarised in Table 5.

Table 5. Advantages and disadvantages of light scattering optical smoke detectors.

Advantages	Disadvantages
Sensitive to larger smoke particles created by a smouldering fire	Less sensitive to smaller particles created from a flaming fire
Relatively cheap and robust	Less sensitive to darker fumes

3.3.3 Light obscuration optical smoke detectors

An obscuration detector consists of a transmitter (light source) that sends out infrared light and a light sensitive receiver. The difference with the above mentioned optical smoke detector is that the incident light constantly affects the receiver. However when smoke enters in between the transmitter and receiver there will be a decrease in intensity, and at a certain level of decrease the detector will activate (see Figure 5).

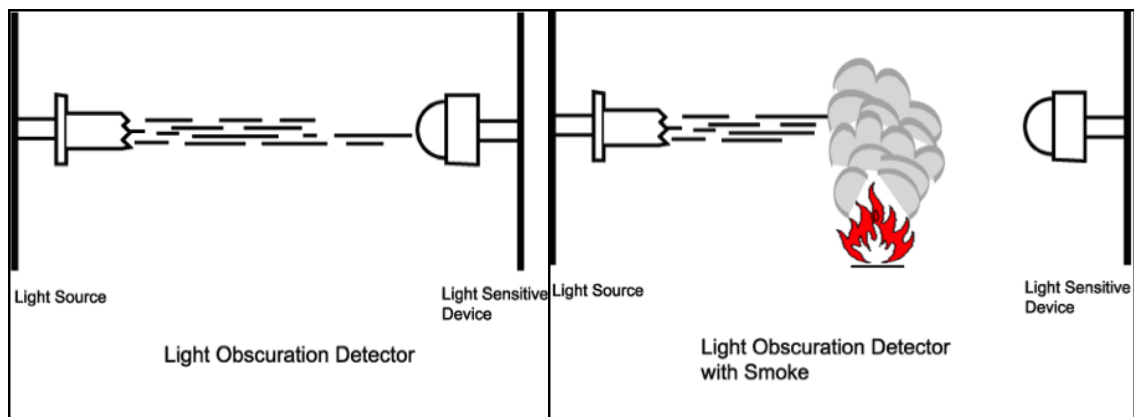

Figure 5. Example of how light obscuration detector works [6].

Light obscuration detectors activates similar on both bright and dark fumes. On the downside it requires a larger amount of particles in the fumes since it measures the difference in light intensity. It also needs to be protected from other light sources that might interfere with its functions. Advantages/disadvantages are summarised in Table 6.

This detector type can be used both as a point or line detector, which can cover distances up to 100 metres, at least. The line type detector is ideal for long corridors and high atriums.

Table 6. Advantages and disadvantages of light obscuration optical smoke detectors.

Advantages	Disadvantages
Sensitive to both bright and dark fumes	Requires a larger amount of smoke particles
Possibility to cover long distances	Sensitive to other light sources

3.3.4 Aspirating smoke detectors

This detector type often uses the same principles as light scattering optical smoke detectors. The difference is that they sample in one space and analyse them in another by constantly drawing in air (hence aspirating) into the holes of a pipe network. This is achieved by a fan, and the air is transported to a filter where dust and other contaminants are removed. The air then enters the detection chamber which may use light scattering technology, often based on laser technology to detect the presence of very small amounts of smoke particles. Detectors of this type are often fitted with a flow meter to ensure a constant suction by the fan.

Advantages and disadvantages for this detector can be seen in Table 7.

Table 7. Advantages and disadvantages of aspirating smoke detectors.

Advantages	Disadvantages
Can cover a large area	Dilution of smoke if many sampling holes are used
The sensor may be located in a clean environment	Potential long delay times before the smoke reaches the detector
Low false alarm rate when using a filter	

3.4 Flame detection

Characteristic for detectors of this type are that they oversee a specific volume, e.g. a room. The fire signature they react to is radiation emitted from a flame, which cover both the ultraviolet (UV), visible, and infrared (IR) spectrum. Soot will radiate almost as a black body, which means that there will be a large radiation spectrum. However, specific molecules will also radiate at specific narrow bands either in the UV or in the IR region. UV radiation is due to electron transitions and IR radiation is due to molecular vibrations. Flame detectors are usually constructed to detect radiation at these narrow bands to be able to distinguish a flame from other radiation sources. The detector can be constructed to detect only UV-radiation or IR-radiation, or both.

Typical for flame detectors is that they are the fastest ones to detect a flaming fire, but that they could have a high false alarm rate [2]. Due to the fast response time of a flame detector they are widely used in high risk areas, where e.g. explosions may occur. For a flame detector to function at its best it should be fitted in a large open area. This is because the detector must “see” the fire. Corners and objects blocking the detector may therefore interfere and stop the radiation needed for detection.

Advantages/disadvantages for flame detectors are summarised in Table 8.

Table 8. Advantages and disadvantages of flame detectors.

Advantages	Disadvantages
Very fast response time in case of a flaming fire	Could be sensitive to false alarms
Volume detection	The fire might be obstructed
	Some flame detectors cannot detect slow growing fires due to background compensation

3.4.1 IR detectors

IR detectors often use different filters to be either single frequency detectors or multi spectrum detectors.

The single frequency detectors are designed to detect light intensity at specific wavelengths. Typical in a fire situation is the combustion product carbon dioxide that emits radiation at specific wavelengths where a detector would activate. The single frequency detector is often set to only detect radiation that fluctuates in intensity between certain intervals typical for an open flame. This will exclude the activation of radiation from e.g. radiators that does not tend to fluctuate as much as open flames. However, it might still be activated by e.g. the fluctuation from the sun reflecting in water. [1]

The multi spectrum detectors operate in different wavelength intervals. Typical for this detector type is to compare the radiation intensity of different wavelengths, such that the detector can distinguish a fire from other radiating items.

3.4.2 UV detectors

UV-detectors use the same principles as IR detectors, but detect radiation in the UV region. The UV-radiation is emitted by radicals, which are intermediate species produced in combustion processes. The detector is more resistant than IR detectors to activate due to sunlight since the atmosphere absorbs much of the UV radiation.

Some substances, e.g. toluene, acetone or ethanol, absorb UV-radiation and might screen the incident radiation. Even fumes produced by fires might screen the detector from UV-radiation. This is crucial in the placement of the detector [1].

3.4.3 UV/IR-detectors

These combine the principles of the two flame detector techniques that were explained above. To activate an alarm both mechanisms must detect. Therefore this detector reduces the amount of false alarms due to its redundancy.

3.5 Combined/multi detection

Commonly used today are the so called combined detectors that are combinations of two or more detection types. One popular solution is to combine an optical smoke detector with a heat detector. This gives a more reliable detector where only certain combinations of the signals activates the detector. The algorithms make the detector more resistant against false alarms [1].

3.6 False alarms

False alarms or nuisance alarms are the results of detectors activating when there is no fire or, more generally, when one does not wish the detector to activate. The alarms occur when the detectors sense parts of what could be a fire signature. Heat detectors react on heat, smoke detectors react on particles in the air and flame detectors reacts on light. To decrease the number of nuisance alarms or even eliminate them one designs the detectors to recognise certain characteristics of a fire and to dismiss sources of false alarms. One can stop dust particles from reaching a smoke detector using filters, flame detectors can dismiss a stable light source because it does not flicker like a flame would, and heat detectors using rate-of-rise can dismiss a high engine compartment temperature since a fire would cause the temperature to rise faster than the engine-induced heating of the compartment.

It is important that fire detection systems are not sensitive to false alarms sources since reoccurring false alarms will become a nuisance and suppression systems may be unnecessarily activated.

In Table 9 there is a short list of possible false alarm sources for different types of detectors.

Table 9. Different sources of false alarms connected to the affected detection methodology

Detection system methodology	Possible false alarm sources
Heat detectors	Hot surfaces, e.g. turbocharger in engine compartment; high ambient temperature.
Flame detectors	Flashes of light; lit cigarettes; arc welding; sunlight (direct or reflected); radiation from hot surfaces.
Smoke detectors	Exhaust fumes; oil or grease on hot surfaces; degreaser on hot surfaces; glycol on hot surfaces; road dust.
Gas detectors	Diesel or oil vapour; exhaust fumes.

4 Alarm systems

The detectors or sensors described in previous chapter simply detect the presence of a fire signature. This would be useless unless anyone or anything notice it and take action. Alarm systems can be designed in many ways; it can either give a signal by sound (acoustical), by a flashing light (optical) or by an indication on a monitored control panel and eventually automatically activate a suppression system.

Alarm systems of today are often flexible and customised. The core of an alarm system is the control unit containing all central functions for detection, alarm, suppression, and other vital functions. Depending on the complexity and the degree of automation, possible actions after a detector activates may be; an acoustical and visual signal, activation of the suppression system, fire barriers automatically shut, the ventilation system shuts down and fire ventilation starts [7].

The bulk of alarm systems only use output signals from the detector, representing the value of what is detected. These signals are then interpreted by the control unit that decides if there is a fire, fault or something else. In a more complex system each detector has its own computer that evaluates its surrounding environment and decides if there is a fire, fault or something else. It may even signal when the detector head is soiled and adjust its threshold activation level in order to maintain constant sensitivity [8].

With a programmable system it could be possible to receive output and input data of the systems functionality by downloading it from the control unit. It is also easy to change the function of each detector; activation level or disconnect one function in e.g. combined detectors. It could also be possible to replace a detector that malfunctions and the new one will automatically adjust to the latest settings made in the control unit [7].

4.1 Conventional and addressable systems

In a conventional system all signals from detectors in a certain area represents the alarm address. This means that the fire cannot be specifically located to a single detector, but simply an area of detectors. This may also mean that a suppression or extinguisher system activates over the whole area instead of locally above the fire source.

In an addressable system each detector has its own alarm address. This means that the exact position of the activated detector can be determined. When connected to a suppression/extinguishing system this may enable system activation in only the fire affected zone instead of the whole section [8].

4.2 Redundant systems

Increased reliability of the systems could be achieved by redundancy. Systems can be connected in *closed loops* as seen in Figure 6 and Figure 7, which ensure that all detectors can be functional and accessed even with a breakage somewhere. The opposite is to use an open loop, see Figure 8, which mean that a detector will not be functional in case of a breakage. Improved redundancy can be obtained by using two or more control units (Figure 7), in case one control unit breaks down. They all share the same information, but with one control unit lost the other will take over the system and no information will get lost.

Another example of redundancy is short circuit isolators, which are placed in segments in the loop. Without isolators, the whole system could break down in case of a short circuit, but with short circuit isolators the detectors before or after the affected segment could still be operational [3].

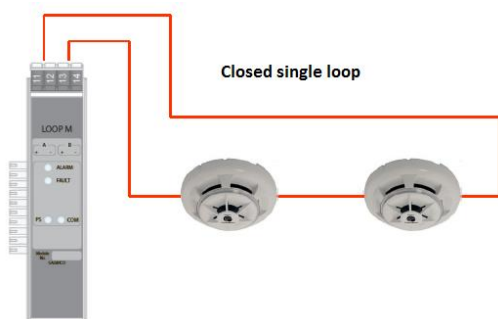

Figure 6. Example of a closed single loop [3].

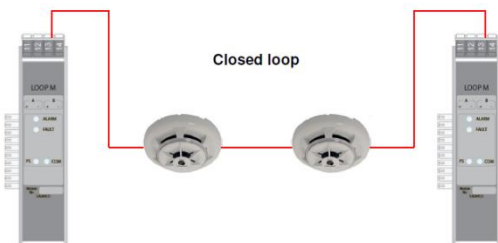

Figure 7. Example of closed loop with two control units [3].

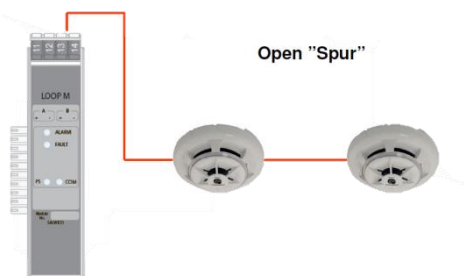

Figure 8. Example of an open loop [3].

5 Standards and Guidelines

Today, the European legislation for buses, UNECE Regulation 107, requires that the driver is provided with an acoustic and a visual signal in case of an excess temperature in the rear engine compartment [9]. Existing automotive requirements, like Regulation 107, are short and limited regarding fire detection and do not ensure fast and reliable detection of a fire. It is hard to find any applicable standards or guidelines focused on fire detection in heavy vehicles, but last in this chapter some standards for vehicle applications are presented. However, if fire detection is covered at all it is very briefly. Other closely related standards is a NATO standard about fire detection and firefighting systems in main battle tanks [10] and EN 14604 [11] and UL 217 [12] which both have a small part about smoke detectors in recreational vehicles (subchapter 5.1.2 and 5.1.6.1). There are, however, many standards and guidelines regarding fire detection in other areas of application. Below some of the most relevant standards and guidelines for fire detection in buildings, trains, aircrafts, and ships are presented and summarised.

5.1 Buildings

5.1.1 EN 54 Fire detection and fire alarm systems

EN 54 [13] is a European standard focused more on product approvals than application considerations. This makes it quite general and more of a product standard than an application standard for fire detection in buildings. However, it is clearly stated that the standard is only valid for fire detection in buildings, but that it could be used as guidance for other applications. EN 54 specifies requirements, test methods, and performance criteria for fire detection and fire alarm systems. Looking at the different tests it is apparent that all tests cannot be used directly for approval of fire detection in e.g. engine compartments of heavy vehicles due to large environmental differences regarding e.g. temperature, airflow, vibrations, and dust levels.

The EN 54 standard contains several chapters with their own releases where each chapter covers a specific component (with a few exceptions) in the fire alarm system. E.g. there are different chapters for power supply equipment, indicating equipment, short circuit isolators, radio links, etc. and then different chapters for heat detectors, smoke detectors, flame detectors and so on. All chapters in EN 54 are listed in Appendix A which also lists chapters under development [14]. Below some of the chapters covering different methods of detection are covered more closely.

5.1.1.1 EN 54-5 Heat detectors – Point detectors

The chapters in EN 54 about different types of detection methods are structured in the same way. There are initially a few pages about the scope, references, terms and definitions, and some general requirements before the main part, which consists of an extensive test program for approval. An overview of all tests that shall be conducted for EN 54-5 is presented in Table 10, second column. The numbers present how many different tests that are described regarding that topic, but each test may require several repeats or consist of different parts that will be carried out after each other. Because of that the number of different samples that are needed varies for each test. Table 10 also presents a comparison of the test programs in the different chapters in EN 54 and other standards described later in Section 5.1. The comparison should be used as a rough overview, because one standard may for example have one test covering two different topics that are covered by two separate tests in another standard.

Table 10. Test program for different standards. (Numbers present different types of tests specified, the same type of test could be required several times.)

Focus of test(s):	EN 54-5 (heat)	EN 54-7 (smoke)	EN 54-10 (flame)	EN 54-20 (asp.)	ISO 7240-15 (multi)	ISO 7240-22 (duct)	FM 3210 (heat)	FM 3260 (flame)	UL 268 (smoke)	UL 268A (duct)	UL 521 (heat)
Directional dependence	1	1	1		1			1	1		
Static alarm temperature	1						1				1
Response times	3						1-2				2
Fire/smoke sensitivity		1	1	1	1	1		1	3	1	
False stimuli								1			
Smoke entry/air leakage						1			1	1	
Air movement		1			1				2	1	
Dazzling by artificial light sources		1	1		1	1					
Variation in supply parameters	1	1	1	1	1	1					
Repeatability		1	1	1	1	1					
Reproducibility	1	1	1	1	1	1					1
Cold	1	1	1	1	1	1	1	1	1	1	1
Dry heat	1	1	1	1	1	1	2	1	2	2	2
Damp heat/Humidity	2	2	2	2	2	2	1	1	1	1	1
Corrosion	1	1	1	1	1	1			1	1	1
Shock/impulse/dynamic load	1	1	1	1	1	1					1
Mechanical impact upon surface	1	1	1	1	1	1	1		1	1	1
Vibrations	2	2	2	2	2	2	1	1	1	1	1
Stability (several small tests)									1		1
Wear/durability							1	2	2	1	3
Dust							1		1		1
Electromagnetic Compatibility (EMC)	5	5	5	5	5	5	4	3	6	5	6
Electrical supervision/circuit measure									2	2	2
Voltage Range							1	1	1	1	1
Reverse Polarity							1		1	1	1
Overload									1	1	1
Bonding to ground							1	1			
Signal processing								1			
Abnormal operation									1	1	1
Survivability to hot temperatures (short time)									1		
Additional tests for special marked detectors	2										
Enclosure/part replacement							1	1	3	3	2
Other component tests									6	4	2
Total number of tests	21-23	21	20	18	21	20	18-19	16	40	29	33
Minimum no. of specimens (non-resettable)	15 (62)	20	8	8	20	13	12	4	28	28	15 (50)

In EN 54-5 the general requirements state that a point heat detector shall belong to one or more of the classes in Table 11. This means that the maximum application temperature of a point heat detector approved to EN 54 is 140°C, with maximum response (alarm) temperature of 160°C. However, it is common with alarm temperatures higher than 160°C for heat detectors mounted in engine compartments of heavy vehicles and they can therefore not be approved to EN 54-5. The reason that the minimum response temperature is 4°C higher than the maximum application temperature is to avoid false alarms.

Further requirement is that all point heat detectors shall have their heat sensitive element at least 15 mm from the mounting surface of the detector. Other general requirements cover documentation, marking, connection of ancillary devices, adjustments, and indication in case of an alarm. For software controlled detectors there are some additional requirements mainly about reliability and documentation.

Table 11. Point heat detector classification.

Detector Class	Typical Application Temperature °C	Maximum Application Temperature °C	Minimum Static Response Temperature °C	Maximum Static Response Temperature °C
A1	25	50	54	65
A2	25	50	54	70
B	40	65	69	85
C	55	80	84	100
D	70	95	99	115
E	85	110	114	130
F	100	125	129	145
G	115	140	144	160

The chapter's main part is the test program. To test a heat detector the response time of the detector is measured, which means the time interval between the start of a temperature increase from the application temperature to an alarm. For this purpose a heat tunnel is used, where the temperature and airflow are controlled very precisely. EN 54-5 prescribes the working section of a heat tunnel, see Figure 9. In the working volume the temperature and airflow shall be controlled with an accuracy of ± 2 K and ± 0.1 m/s at all times during the test. The airflow shall be laminar with the velocity 0.8 m/s at 25 °C and then controlled to maintain a constant mass flow. Care should be taken so that the air after it passes the heater is mixed properly before it enters the working volume through a flow straightener. There are some additional requirements on distances in the working section and dimensions for the mounting board, but besides that it is free design of the heat tunnel. For example it is free to decide if it should be a circulating or a non-circulating tunnel.

The response time is measured for several different rate of rise of the air temperature and the requirements are stated in Table 12. The upper limits are derived from the theoretical response time of a fixed temperature heat detector with a specified time constant T , which in this case is set to 20 s for A1 detectors and 60 s for all other detectors. The lower limits are there to minimise the number of false alarms and are based on analyses of existing rate of rise heat detectors. The response time limits specified in Table 12 are from typical application temperatures for the detectors. There are other tests where the response time is measured from ordinary room temperature regardless of the detector's class or from

higher temperatures than the typical application temperature. Of course these tests include other response time limits.

Almost all other tests also include measurements of the response time. For example the directional dependence test where the response time is measured for several different orientations of the detector and all environmental tests where the response time of the detector after exposure of cold, heat, vibration or EMC, etc., is compared to the response time in an earlier test. Regarding the environmental tests (except EMC) these refer to another standard of the International Electrotechnical Commission, IEC 60068-2, where the test setups and procedures are described. The EMC tests are described in EN 50130-4.

EN 54-5 also specifies some additional tests for suffix S and R detectors. A suffix S detector shall not respond below the minimum static response temperature and will be subjected to a plunge test, which means a test where the detector is plunged into an airstream of temperature just below the minimum static response temperature. A suffix R detector is able to give an alarm on rates-of-rise also below the typical application temperature and will be subjected to a test where the initial temperature is 20 °C below the typical application temperature, but the response time limits are still the ones presented in Table 12.

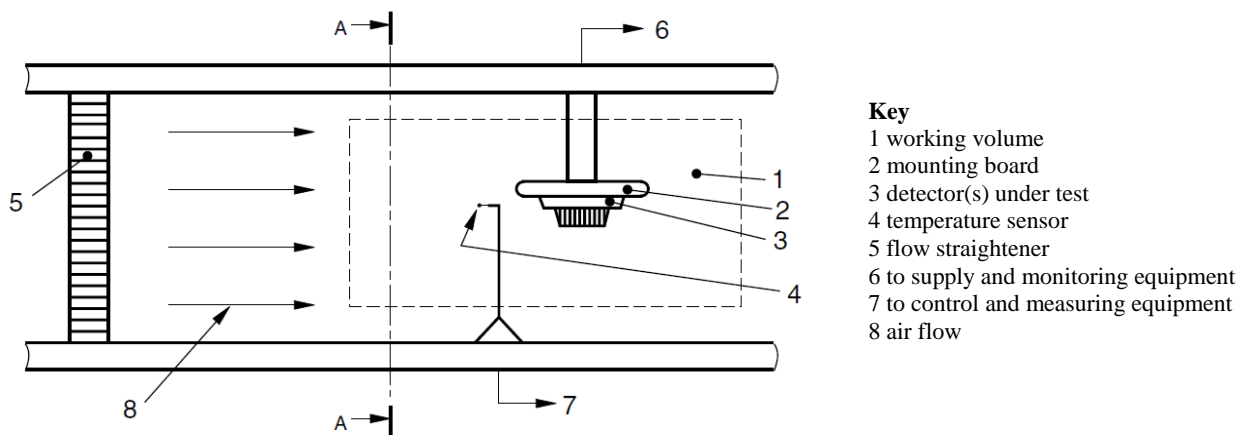

Figure 9. Working section of a heat tunnel.

Table 12. Response time limits from typical application temperatures. (Class letters are explained in Table 11).

Rate of rise of air temperature K min ⁻¹	Class A1 detectors				Class A2, B, C, D, E, F & G detectors			
	Lower limit of response time		Upper limit of response time		Lower limit of response time		Upper limit of response time	
	min	s	min	s	min	s	min	s
1	29	0	40	20	29	0	46	0
3	7	13	13	40	7	13	16	0
5	4	9	8	20	4	9	10	0
10	1	0	4	20	2	0	5	30
20		30	2	20	1	0	3	13
30		20	1	40		40	2	25

Recently the chapter EN 54-22, Resettable line type heat detectors, was published, which together with EN 54-28, Non-resettable line type heat detectors, (still under development) cover the today most common type of detectors installed in engine compartments of heavy vehicles. However, these chapters are very similar to EN 54-5 and the only major differences are how to install these detectors in the heat tunnel.

5.1.1.2 EN 54-7 Smoke detectors – Point detectors using scattered light, transmitted light or ionization

The structure of EN 54-7 is very similar to EN 54-5. In the general requirements much are the same, but of course there are also some requirements that are specific to heat or smoke detectors. For example, EN 54-7 requires the detector to be designed such that a sphere of diameter 1.3 ± 0.05 mm cannot pass into the sensor chamber and also that drift compensation shall not cause a significant reduction of the detector's sensitivity to slowly developing fires. Drift compensation means that the drift due to dirt build up in the sensor chamber or aging of components is compensated for with a higher or lower alarm level. This will affect the sensitivity to slowly developing fires, but the standard sets out requirements such that the effect is limited.

The test program is presented in Table 10, column 3, and the test procedure is similar to that in EN 54-5 for heat detectors. However, instead of measuring the response time in a heat tunnel the response threshold value, which is a measurement of the aerosol density at the time for an alarm of the detector, is measured in a smoke tunnel. The description of the smoke tunnel is very similar to the heat tunnel, with the addition of some extra measurement components, see Figure 10. The only difference between Figure 10 and Figure 9 is the obscuration meter and the MIC (measuring ionization chamber). The obscuration meter is the reference meter for aerosol density when testing detectors using scattered or transmitted light and the MIC is the reference meter when testing detectors using ionization. The airflow in the working volume shall be laminar and controlled at either 0.2 ± 0.04 m/s or 1.0 ± 0.2 m/s depending on the test. The temperature shall be 23 ± 5 °C, but adjustable up to 55 °C. To control the increase of aerosol density it is recommended to use a circulating tunnel, and it is also recommended to feed the test aerosol to the tunnel upstream of the fan to get efficient mixing. Important is that a purging system is required to clean the smoke tunnel after each test.

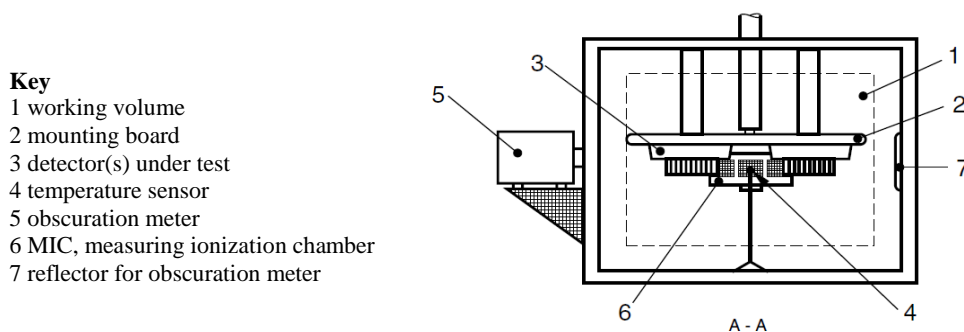

Figure 10. Smoke tunnel. Cross section A-A, refer to Figure 9.

The test aerosol used in the tunnel shall be polydisperse, and the particle diameters shall peak between $0.5 \mu\text{m}$ and $1 \mu\text{m}$. The aerosol shall be reproducible and stable regarding particle mass distribution, optical constants, particle shape, and particle structure. Recommended is to use an aerosol generator producing paraffin oil mist.

The test procedure is then very similar to the one described for heat detectors in EN 54-5. The detector is exposed to e.g. cold and then the response threshold value is measured and compared to the value received before the exposure. One test is however very

different from the others: the fire sensitivity test. In this test the detectors are mounted in the ceiling of a fire test room and exposed to different types of smoke from real fires. The four different types of fires that the detectors shall be exposed to are:

- Smouldering (pyrolysis) wood fire
- Glowing smouldering cotton fire
- Flaming plastics (polyurethane) fire
- Flaming liquid (n-heptane) fire

The requirement is that all detectors shall respond to each fire before the end of the test.

5.1.1.3 EN 54-10 Flame detectors – Point detectors

The test program for flame detectors in EN 54-10 is presented in Table 10, column 4, and the similarity with the other chapters in EN 54 is notable. Much of the general requirements are the same and also the structure and test procedure. For flame detectors the response points are measured, instead of e.g. the response times for heat detectors or the response threshold values for smoke detectors. The response point (D) is the greatest distance at which the detector will produce an alarm within 30 s in a setup according to Figure 11.

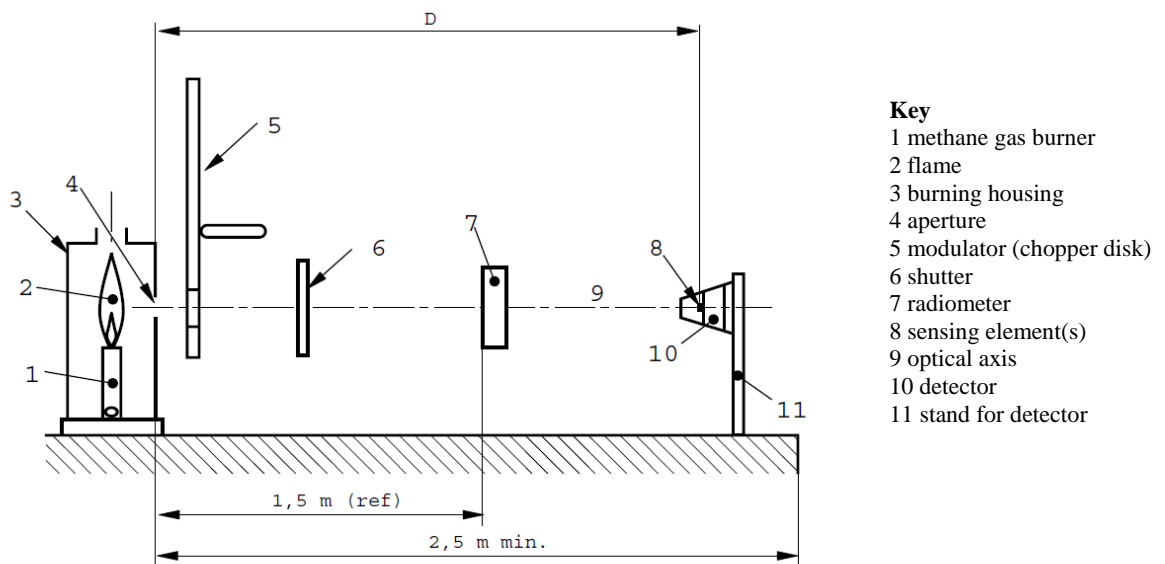

Figure 11. Setup for response point measurements for flame detectors.

The aperture shall be constructed in such a way that the complete area is filled by the flame when viewed from any allowable positions of the detector and in a way that the response point in the initial reference test lies within 1.3-1.7 m. The role of the radiometer is to assure that the source radiance does not vary more than 5% throughout the tests. Some flame detectors respond to radiation differences only and not to absolute radiation intensities. They may also be optimized for variations at specific frequency intervals typical for flame flickering. For that reason the modulator in Figure 11 is used at a frequency corresponding to the peak signal of the detector. It may seem strange that the setup is optimized for the detector tested, but the measurements in this setup is only used as reference values for the detector currently tested. An absolute sensitivity test is performed in a separate setup described last in this section.

For flame detectors the directional dependence test plays an important role because flame detectors as opposed to heat and smoke detectors face a specific direction. The field of view determines at what angles the detector is able to detect, but in general the detector's

sensitivity decreases with the angle measured from normal incidence to the detector's sensing element. Another important test is the dazzling test because flame detectors react on the emitted light (IR or UV radiation) from the flame and should be able to do that also in very bright conditions. For example, an incandescent lamp emits a lot of radiation in the infrared and should neither give a false alarm nor dazzle the detector such that it will not detect a real fire.

For flame detectors there is, as for smoke detectors, a fire sensitivity test where the detectors look at different fires. In EN 54-10 the flame detectors will look at an n-heptane fire and a methylated spirit fire, and all detectors shall detect the fires within 30 s. Depending on what distance the detectors are able to detect the fires, the detectors will be categorised into different classes. All detectors approved to EN 54-10 must detect the fires at a distance of 12 m and this corresponds to Class 3. If the detectors are able to detect the fires at a distance of 17 m they will be approved to Class 2 and detection at 25 m will approve the detectors to Class 1.

5.1.1.4 EN 54-20 Aspirating smoke detectors

Also EN 54-20 follows the structure and test procedure described above for the other chapters in EN 54. In the general requirements section there are mainly two additional requirements that cannot be found in EN 54-7 about point-type smoke detectors. These are requirements on airflow monitoring and requirements on the mechanical strength of the pipework. The airflow shall be monitored to detect leakage or other faults in the sampling system and regarding the mechanical strength the pipes have to be classified in accordance with EN 61386-1 to at least Class 1131. The three numbers (1-1-31) are in turn classes for resistance to compression, resistance to impact, and temperature range.

The test program for aspirating smoke detectors is presented in Table 10, column 5, and it is just a few tests that differ from the other chapters. As for point-type smoke detectors the response threshold value is measured for the different tests and compared with a reference value. Since there are many different types of aspirating smoke detectors operating on different principles and with different ranges of sensitivity, there are various methods for measurement of the response threshold value. EN 54-20 just states that the aerosol concentration shall be measured when causing an alarm after passing through the detector. Since it is only relative measurements of the response threshold value, many different setups and measurement technologies may be used. EN 54-20 presents two examples of setups and measurement methods. In the first method a fairly complex system is used where the smoke from an aerosol generator is mixed with clean air in a dilution system and a condensation particle counter (CPC) is measuring the aerosol concentration. The CPC samples the aerosol from the dilution system in the same manner as the aspirating detector, which enables a correct measurement of the concentration at the detector. In the second method the smoke tunnel described in EN 54-7 is used to generate and measure the initial smoke concentration. The aspirating smoke detector is then sampling smoke from inside the tunnel and clean air from outside the tunnel as a second stage of dilution. Care should be taken such that the second stage of dilution is repeatable and that the parameters are constant since the aerosol concentration measured in the smoke tunnel is not a direct measurement of the concentration at the detector of the aspirating system.

The test procedure is then very similar to EN 54-7 except the fire sensitivity test that differs a little. Aspirating smoke detectors are divided into three different classes depending on what fire sensitivity test they pass. Class C represents normal sensitivity, and the detector shall give an alarm at least at an equivalent level as a point-type smoke detector placed at the position of the sampling hole. The test fires for Class C are then the same as in EN 54-7. Class B represents enhanced sensitivity and Class A very high sensitivity, and the test fires for these classes are reduced versions of the fires in EN 54-7

such that the smoke production is at a lower rate. It is important to realise that the classes only define the sensitivity of the holes and not of the detector. For example, a detector with 20 “Class A holes” where each hole is capable of detecting all class A test fires is more sensitive than a detector with 5 “Class A holes” since every hole not exposed to smoke will sample clean air and dilute the smoke before it reaches the detector. It is therefore important to know how many holes the system had when it was tested.

There exist systems basically consisting of an ordinary point-type smoke detector, a fan, and a pipe. Such a system can be approved to either EN 54-7 or EN 54-20 Class C. However, to be approved as an aspirating smoke detector there are extra requirements on airflow monitoring and pipework mechanical strength, as mentioned above.

5.1.2 EN 14604 Smoke alarm devices

EN 14604 [11] covers smoke alarms intended for household applications. It is very similar to EN 54-7, but has additional requirements and testing regarding e.g. sounder, power source, back-up battery, and inter-connectable devices.

Of interest is that EN 14604 also has a short annex about alarms for installation in leisure accommodation vehicles. There is one extra test required for this application in addition to all other tests specified in EN 14604. The supplementary test is a temperature cycle over 24 hours that shall be repeated 10 times in a row. The cycle starts at 25 °C, rises to 65 °C, drops to -10 °C and then back to 25 °C. At the maximum and minimum temperatures the conditions will be stationary for about 7 hours. (Compare with data in Table 14).

5.1.3 ISO 7240 Fire detection and alarm systems

International Organization for Standardization, ISO, develops and publishes international standards [15]. ISO 7240 [16] is the international counterpart to EN 54 and in many parts they are almost identical. All chapters in ISO 7240 are listed in Appendix B and a comparison between ISO 7240 and EN 54 shows that many chapters cover the same topic. The structure, content, and test procedure in these chapters are very similar, but the chapters do not need to be identical because there are different workgroups preparing ISO 7240 and EN 54. There are also chapters in ISO 7240 not having a counterpart in EN 54, and vice versa, chapters in EN 54 not having a counterpart in ISO 7240. However, for example chapter 9 in ISO 7240 about test fires is in EN 54 incorporated in the chapters where the test fires are used. The definitions of the test fires are the same in the two standards and there are nine test fires, TF1-TF9, see Table 13. Two of the chapters in ISO 7240 are presented and summarised below.

It should also be mentioned that Standards Australia has adopted ISO 7240 into their standards under the name AS 7240. This Australian standard is just a slightly modified version of ISO 7240.

Table 13. Test fires in ISO 7240.

TF1	Open cellulosic wood fire
TF2	Rapid smouldering pyrolysis wood fire
TF2a	Slow smouldering pyrolysis wood fire
TF2b	Smouldering pyrolysis wood fire
TF3	Glowing fast smouldering cotton fire
TF3a	Glowing slow smouldering cotton fire
TF3b	Glowing smouldering cotton fire
TF4	Open plastics polyurethane fire
TF5	Liquid n-heptane fire
TF5a	Small liquid n-heptane fire
TF5b	Medium liquid n-heptane fire
TF6	Liquid methylated spirit fire
TF7	Slow smouldering pyrolysis wood fire
TF8	Low temperature black smoke liquid decalin fire
TF9	Deep seated smouldering cotton fire

5.1.3.1 ISO 7240-15 Point-type fire detectors using smoke and heat sensors

This standard requires at least one smoke sensor and one heat sensor. As mentioned above the chapters in ISO 7240 follow the same structure as in EN 54. The general requirements cover basically the same matter as for smoke and heat detectors in EN 54-5 and EN 54-7, which include documentation, marking, connection of ancillary devices, adjustments, indication in case of an alarm, requirements for software-controlled detectors, monitoring, drift compensation, etc. The main thing not included in ISO 7240-15 is the different classes for heat detectors, which is due to the fact that there are no requirements on the heat sensor to detect a fire at a certain temperature or at a specific rate of rise. The performance requirement is to detect a number of test fires similar to the requirement for ordinary smoke detectors, which means that the different sensors are not tested to see if they are capable of detecting a fire on their own.

The test program is presented in Table 10, column 6, and the similarity with EN 54-7 about point-type smoke detectors is clear. The procedure is also the same and the response threshold value is measured in a smoke tunnel identical to the one described in EN 54-7. The difference is that also the temperature response value is measured in all tests in the heat tunnel described in EN 54-5. The temperature response value is specified by the manufacturer, which means that there are no absolute requirements on the temperature response value as in EN 54-5. The manufacturer also specifies the rate of rise within the range 3 K/min to 20 K/min that shall be used in the heat tunnel. Important to note is that the response values are only used as reference values to compare different detectors e.g. in the reproducibility test or the same detector before and after e.g. the vibration test.

In the fire sensitivity test the ability to detect real fires is tested. The test is almost the same as in EN 54-7 but with one additional test fire, TF8, which means that the following fires are tested:

- Smouldering (pyrolysis) wood fire
- Glowing smouldering cotton fire
- Flaming plastics (polyurethane) fire
- Flaming liquid (n-heptane) fire
- Low-temperature black-smoke liquid (decalin) fire

TF1 and TF6 are also mentioned as optional test fires, see Table 13.

5.1.3.2 ISO 7240-22 Smoke-detection equipment for ducts

This chapter is interesting because it handles detection in very high airflows, which also is the case in most engine compartments of heavy vehicles. However, ISO 7240-22 only covers smoke detectors that sample air from the duct, which means that the detector itself is not placed in the high airflow.

The detector in the system may be a smoke detector approved to ISO 7240-7, which essentially is the same as EN 54-7, or a detector complying with the tests specified in ISO 7240-22, see test program in Table 10, column 7. Since a smoke detector approved to ISO 7240-7 is accepted when sampling air from the duct, the requirements and test procedure in ISO 7240-22 is very similar to the requirements and test procedure in ISO 7240-7. The things that differ are mentioned below.

The smoke tunnel is adapted for duct application, which means higher airflows and that the detectors are placed outside the tunnel. ISO 7240-22 specifies some parameters that shall be fulfilled and gives an example on what the tunnel could look like, see working section in Figure 12, but there are no requirements on the design. The airflow shall be variable from 1 m/s (± 0.2) to 20 m/s (± 4.0), and to get a laminar flow at such high air velocities the tunnel should be quite long (10 meters in one direction is given as an example) compared to what is needed for the tests in EN 54-7. As can be seen in Figure 12 the air from the tunnel is sampled into an enclosed box outside the tunnel where the detector is placed.

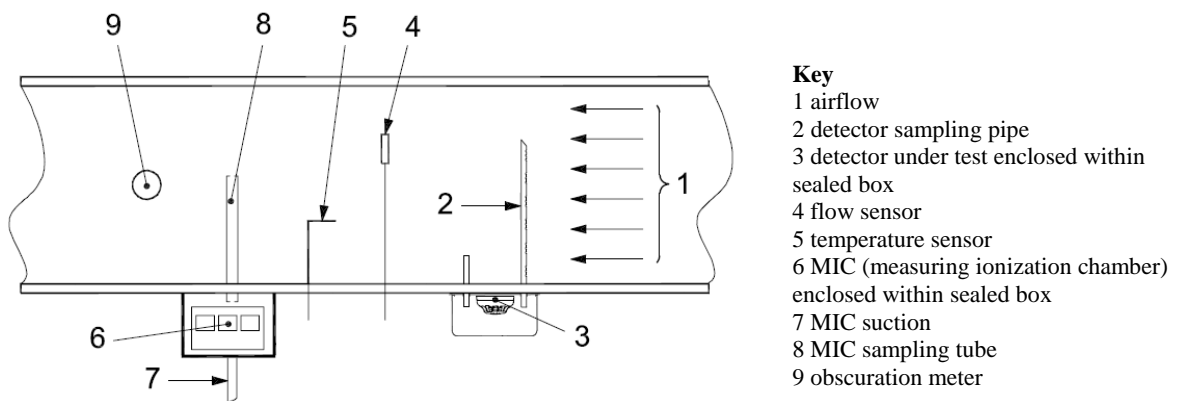

Figure 12. Duct-tunnel working section, top view.

One test that is included in ISO 7240-22, but which is not included in the test program for ordinary point-type smoke detectors according to ISO 7240-7, is the air leakage test. This test will ensure that the detector sampling box is sealed and that the leakage from the sampled environment is minimal. A confined sampling space is subjected to both underpressure and overpressure for 10 minutes each, and the leakage shall be limited to specified requirements.

Regarding the fire sensitivity test there are two differences compared to the test in ISO 7240-7 and EN 54-7. Firstly there are just two test fires used, TF2 and TF4, see Table 13. Secondly the smoke produced in the fire test room is circulated through the duct-tunnel where the detector is sampling air, which gives a realistic air-duct scenario. The tests are performed at two different duct air velocities.

5.1.4 NFPA 72 National fire alarm and signaling code

The National Fire Protection Association (NFPA) is accredited by the American National Standards Institute (ANSI), which is the American counterpart to the European Committee for Standardization (CEN) that provides the EN-standards. NFPA's main goal is to prevent and reduce fires and other hazards, focusing on human lives. One of the things they do is to publish codes and standards [17], e.g. NFPA 72, the US National Fire Alarm and Signaling Code [18].

NFPA 72 is a general and basic standard that establishes the minimum required levels, which other more specific standards can refer to and use as a basis. The focus of NFPA 72 is the entire alarm system with all types of components and it is not just fire alarms but also public emergency alarms and emergency communications systems. In the scope definition it is not stated that the application area is just buildings, but when reading the installation requirements and performance requirements it is implicitly meant for buildings.

A major part of NFPA 72 deals with the electrical signals and components of a fire alarm system. These are the power supplies, circuits, pathways and the signals sent through the system. Notable here is that there are requirements divided into different classes and levels, which means that many different performing components can be approved but to different classes. It does occur, however, that other parts of the code set requirements on which class that should be used if a specific type of alarm system is used. The requirements throughout NFPA 72 are in general very vague and there are few well defined requirements that are easy to measure. It is more common with requirements like "the branch circuit(s) and connections shall be protected against physical damage", and that is all there is. However, this part about electrical signals and components in NFPA 72 also require accomplishment of NFPA 70, the National Electrical Code.

The chapter about inspection, testing, and maintenance is a short chapter and only deals with periodic inspection/testing and maintenance. There is nothing about test methods or test programs for approval, but instead its focus lies on what components shall be inspected or tested and how often they shall be inspected or tested after they have been installed. The test procedures will be prescribed by the manufacturer or be directed by some authority having jurisdiction.

Another chapter covers initiating devices, which means heat detectors, smoke detectors, flame detectors, gas detectors, multi-sensor detectors, etc., but also components for pressure signals, water temperature, manual activation and so on. The requirements are similar to the general requirements in the EN 54 standard with the addition of location and spacing requirements. Since NFPA 72 is more of an application standard there is much focus on the installation of detector systems. Regarding the classification of heat detectors the response temperature range from 39 °C to 302 °C, which is wider than the classification range in EN 54-5. Another interesting requirement is that smoke detectors that are not adapted for special applications shall not be used in temperatures over 38 °C or in airflows exceeding 1.5 m/s. The requirements differ much in generality and, as an example, for gas detectors it is only stated that "the selection and placement of the gas detectors shall be based on an engineering evaluation", while smoke detectors are covered on several pages.

There are two additional chapters covering "notification appliances" (sounder, light signals, etc.), focused on audible and visible characteristics and emergency control function interfaces. These two chapters together with all that is mentioned above cover about two-thirds of the standard and substantially deal with different components of the alarm system. The last third deals with the alarm systems as complete systems with performance and installation requirements. Different chapters cover different types of

alarm systems, for example household fire alarm systems, supervising station alarm systems or emergency communications systems.

There is also a great deal of annexes and particular one is of interest, Annex B. It is an engineering guide for fire detector spacing, which gives a basis and an understanding about what parameters to consider when designing and installing fire detectors. The annex contains formulas for e.g. heat release rate, flame height, response time index, correlations, radiance, plume divergence, smoke layer etc., and some tables and graphs on characteristics from different materials or items. The annex covers heat, smoke, and flame detectors.

5.1.5 FM Approvals

Factory Mutual Insurance Company or, as the communicative name is, FM Global, is an international property insurance company initiated in the US. Their mission is to prevent property loss and one of their businesses is FM Approvals, which certifies products and services for companies worldwide. FM Approvals tests products using a wide range of recognised standards, but they also have over 200 of their own approval standards [19]. The standards covering different types of fire detection are:

- FM 3210 Heat detectors for automatic fire alarm signalling
- FM 3230 Smoke actuated detectors for automatic fire alarm signalling
- FM 3232 Video image fire smoke detectors for automatic fire alarm signalling
- FM 3260 Radiant energy-sensing fire detectors for automatic fire alarm signalling

These standards are focused on product approval and the main content consists of a test program with performance requirements, similar to EN 54. A rough overview of the test programs in FM 3210 and FM 3260 are presented in Table 10, column 8 and 9, and a comparison to the EN- and ISO-standards shows that some parameters and environmental effects are prioritised differently. Interesting is that FM 3260 is the only standard presented in Table 10 with a false stimuli test. As an example, for a radiant energy-sensing fire detector this means response to sunlight, arc welding, heated bodies, incandescent light, etc. Response to light-bulbs is however also tested in some of the dazzling tests.

In addition to a test program the FM standards above also have a quality control program. The program includes facilities audit, installation inspections, maintenance, and documentation requirements. Regarding some other requirements, especially these not specific to the sensing component, the FM standards refer to NFPA 72.

Regarding response time tests and fire sensitivity tests in the four FM standards the following are something of what is mentioned. FM 3210 does not require a specific tunnel or fire test, but still have requirements on the response time. The test may be performed in a fire test room and the detectors shall then, under the same conditions, be at least as quick as comparably rated sprinklers. The test may also be performed in a heat tunnel and for fixed temperature detectors these are plunged into a hot tunnel while rate-of-rise or rate-compensated detectors will experience a continuous heat increase. Depending on the response time FM 3210 classifies heat detectors as standard, quick, fast, very fast or ultrafast detectors.

FM 3230 refers to UL 268 and UL 268A (see next subchapter) regarding open area smoke detectors and duct smoke detectors. Aspirating smoke detectors are allocated some additional requirements in FM 3230 and regarding the fire sensitivity test a single

aspirating port is tested as a spot type smoke detector with test fire; medium cotton wick or paraffin oil.

FM 3232 covers video image fire detectors that shall detect both smoke and flames. In the sensitivity test the standard refers to corresponding UL-standard regarding smoke sensitivity, but provides test description regarding sensitivity to flames. The sensitivity shall be specified as the detector's minimum and maximum distances from the fire when responding before 30 seconds for the following test fires:

- 0.3 × 0.3 m N-heptane pan fire
- 0.3 × 0.3 m alcohol (type specific) pan fire
- 1 m methane flame from a 9.5 mm orifice
- 2 flaming 0.25 × 0.25 × 0.1 m cardboard containers each loaded with 4 crumbled sheets of standard letter size paper

In FM 3260 the radiant energy-sensing fire detectors are categorised as either flame detectors or spark/ember detectors. Flame detectors shall respond to flames in normally illuminated environments while spark/ember detectors shall respond to e.g. embers in coal passing by on a conveyer belt in a location with reduced illumination. In the sensitivity test the detectors shall respond to all of the manufacturer specified fires (must be at least one) and the maximum response distance between the detector and the fire shall be noted. A potential deviation from the response distance specified by the manufacturer shall not exceed 10%.

5.1.6 Underwriters Laboratories

Underwriters Laboratories (UL) is a global safety science company headquartered in the US. They certify, validate, test, inspect, audit, and educate in safety businesses involving products, services, environments, and human life and health. There are more than 130 UL testing and certification facilities around the world and UL have about 1500 published standards for safety [20]. Some of these standards concern fire safety and the main ones about fire detection are:

- UL 217 “Standard for single and multiple station smoke alarms”
- UL 268 “Smoke detectors for fire alarm systems”
- UL 268A “Standard for smoke detectors for duct application”
- UL 521 “Standard for heat detectors for fire protective signalling systems”
- UL 539 “Standard for single and multiple station heat alarms”
- UL 2034 “Standard for single and multiple station carbon monoxide alarms”

Station alarms means one or several units that works alone, compared to alarm systems where several detectors, sounders, etc. is connected to a control unit. These UL standards have the same structure as the FM and EN standards mentioned above with main focus on the approval test program. An overview of the test programs in UL 268 [21], UL 268A [22] and UL 521 [23] are presented in Table 10, last three columns. The splitting of the different test programs in Table 10 were primarily adapted for the EN 54 standard, which implies that some tests may have been split into two tests in Table 10 and vice versa, two tests that have been merged into one test in the table, but it should be nearly correct. As can be seen in the table the UL test programs are similar to the FM test programs, but more comprehensive. It is not just the number of tests that are higher but also the extent of the description regarding both tests and general requirements. As an example UL 268, FM 3230, and EN 54-7, all about smoke detectors in a fire alarm system, may be compared regarding number of pages, which are 168, 25, and 59 pages respectively. For example does UL 268 have 25 pages of construction directive regarding components and assembly, covered (if all) in a few pages in the other two standards.

UL 217 and UL 268 are very similar to each other and the difference is that UL 217 covers ordinary household smoke alarms and interconnected such devices, while UL 268 covers smoke detectors connected to a system control unit in a fire alarm system. According to both standards the smoke detectors are intended for indoor locations in accordance with NFPA 72. The sensitivity tests are the same in the two standards and the smoke tunnel used is free of design provided that a homogeneously mixed and laminar aerosol airflow, adjustable from 0.08 to 0.8 m/s, are obtained. A simple smoke tunnel that may be used is provided as an example in UL 268, see Figure 13. Grey smoke from a cotton lamp wick shall be used or, as an alternative, unspecified aerosol from an aerosol generator with specified build-up rates. As a second sensitivity test the detectors will also be exposed to different test fires in a fire test room approximately 70 m² and 3 meter high. There shall be three flaming fires of paper, wood, and flammable liquid and one smouldering fire of ponderosa pine on a hotplate.

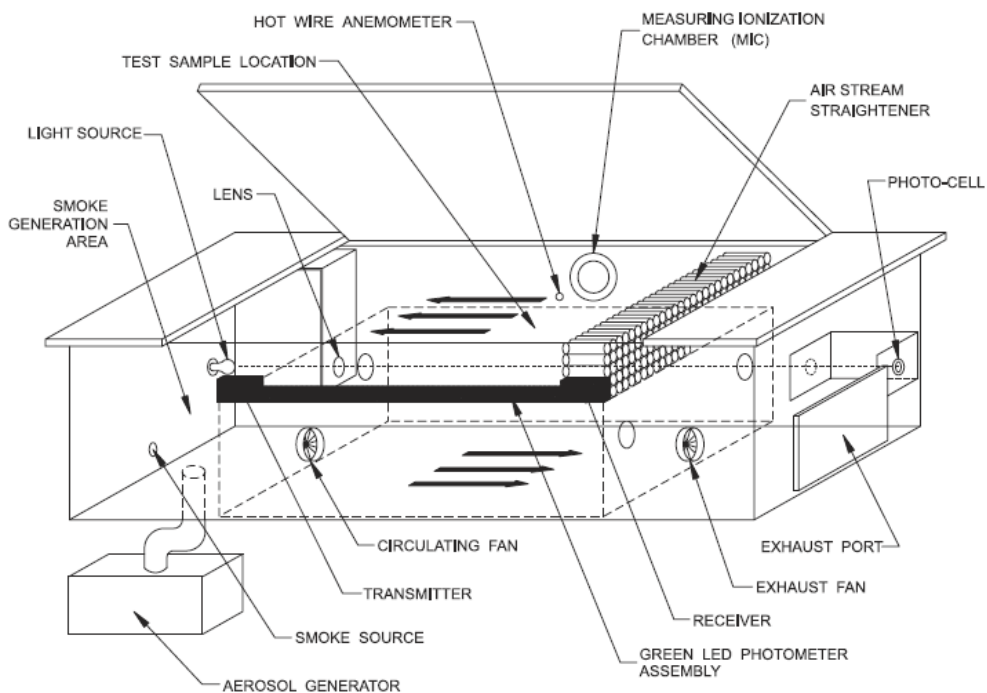

Figure 13. Smoke tunnel in UL 217/268.

The smoke tunnel used in UL 268A has to be larger due to the high airflows in duct applications, also mentioned in section 5.1.3.2 in this report. The detector shall be located at least eight duct widths downstream from the nearest bend and for the tunnel described in UL 268A the roundtrip length is about 22 meters. The smoke detectors are tested with grey and black smoke (pine sticks and n-heptane) in the tunnel. The UL 268A standard mentions that duct smoke detectors shall not be used as a substitute to open area protection, but rather as a complement.

Regarding heat detectors the relationship between UL 521 and UL 539 is the same as for UL 217 and UL 268. The response time tests for heat detectors are basically the same as in FM 3210.

5.1.6.1 Smoke detectors for use in recreational vehicles (part of UL 217)

A small part of UL 217 [12], just three pages, covers additional requirements for smoke detectors in recreational vehicles. There are four tests that are adapted or added for vehicle application: variable ambient temperature and humidity test, corrosion (salt spray)

test, vibration test, and contamination (cooking by-products) test. The contamination test is specific to recreational vehicles and will not be discussed further, but the other three tests are applicable to various kinds of vehicles and it is interesting to see how they are adapted for vehicle application in UL 217. The three tests, adapted for recreational vehicles, originally described in UL 217 and UL 268 as well as described in EN 54-7, are presented in Table 14, Table 15, and Table 16. The data from UL 217 is not from the latest edition, but since it complies with the latest edition of UL 268 nothing should have been changed. It should be noted that the tests for recreational vehicles are additional tests and do not automatically replace the original tests in UL 217.

Table 14. Variable ambient temperature and humidity test.

Recreational vehicles		UL 217/UL 268		EN 54-7	
Condition	Duration	Condition	Duration	Condition	Duration
66 °C	30 days	70 °C	24 h	55 °C	2 h
-35 °C	72 h	-30 °C	3 h	-10 °C	16 h
93% humidity 61 °C	10 days	93% humidity 40 °C	7 days	93% humidity 40 °C	4 + 21 days

Table 15. Corrosion test.

Recreational vehicles		UL 217/UL 268		EN 54-7	
Corrosive substance	Duration	Corrosive substance	Duration	Corrosive substance	Duration
Salt spray (fog)	48 h	Moist H ₂ S-air mixture	10 days	Moist SO ₂ -air mixture	21 days
-	-	Moist CO ₂ -SO ₂ -air mixture	10 days	-	-

Table 16. Vibration test.

Recreational vehicles		UL 217/UL 268		EN 54-7	
Condition	Duration	Condition	Duration	Condition	Duration
Amplitude 0.25 mm, Max. resonant frequency between 10-35 Hz (35 Hz if no resonant)	5 days	Amplitude 0.25 mm, Max. resonant frequency between 10-35 Hz	15 min	Acceleration 5 m/s ² , Frequency range 10-150 Hz, 1 octave/min (freq.)	1 cycle (≈8 min) per axis
		Or 35 Hz if no resonant	4 h	Acceleration 10 m/s ²	20 cycles

UL 268 and EN 54-7 both cover smoke detectors in fire alarm systems for use in buildings, so the comparison between these two standards is also interesting. The variable ambient temperature and humidity test is for EN 54-7 composed of the dry heat, the cold and the two damp heat tests, which last for 4 and 21 days respectively. Some sensitivity measurements of the detectors are conducted before and after the exposures of these environmental tests, but the sensitivity test methodology and the accepted difference between the two measurements could differ between the different standards. The tables above just present the exposure conditions.

In the vibration test the conditions are described with different parameters and for ease of comparison the following should be noted. An amplitude of 0.25 mm in the frequency range 10-35 Hz corresponds to a maximum acceleration of 1-12 m/s². In the UL standards it is not stated that the test should be applied to more than one axis, while in EN 54 the test shall be applied to three perpendicular axes. The duration time for the two vibration tests in EN 54-7, including all three axes, are 24 minutes and 8 hours.

5.2 Trains

5.2.1 EN 45545 Fire protection on railway vehicles

In this European Standard for fire protection on railway vehicles the main objectives are to minimise the probability of a fire starting, to control the rate and extent of fire development and to allow passengers and staff to evacuate the railway vehicle and reach a place of safety. Freight transportation vehicles are not covered by EN 45545.

This European Standard has its background in the International Union of Railways (UIC), responsible for fire safety regulations for railway vehicles and was taken into effect in 2013. This standard supersedes CEN/TS 45545:2009 that was the first version of this standard and was only published as a technical specification. The standard is divided into the seven parts listed below. Part 1 specifies the general criteria for trains such as operation and design categories. Part 2 is in a transitional phase and it is optional to follow this part or a corresponding national standard, but conflicting standards shall be withdrawn no later than March 2016. Part 6 of this standard is the most interesting for this report since it deals with fire detection, fire alarm, and alarm management systems. Presented below is a short summary of Part 1 and Part 6.

- Part 1: General.
- Part 2: Requirements for fire behaviour of materials and components.
- Part 3: Fire resistance requirements for fire barriers.
- Part 4: Fire safety requirements for railway rolling stock design.
- Part 5: Fire safety requirements for electrical equipment including that of trolley buses, track guided buses, and magnetic levitation vehicles.
- Part 6: Fire control and management systems.
- Part 7: Fire safety requirements for flammable liquid and flammable gas installations.

5.2.1.1 Part 1 – General

All trains are different and therefore also the fire protection has to be adapted for each train and where it operates. Part 1 divides the trains into four operational categories, which then decides the vehicle specification regarding running capability (the ability of a train to reach an evacuation point in case of a fire on board). These categories are listed below.

Operation Category 1: Vehicles for operation on infrastructure where railway vehicles may be stopped with minimum delay and where a safe area can always be reached immediately. There are only tunnels and/or elevated sections of length not greater than 1 km.

Operation Category 2: Vehicles for operation on underground sections, tunnels and/or elevated structures, with side evacuation available and where there are stations or rescue stations reachable within a short running time. There are only tunnels and/or elevated sections of length not greater than 5 km.

Operation Category 3: Vehicles for operation on underground sections, tunnels and/or elevated structures, with side evacuation available and where there are stations or rescue stations reachable within a long running time. There are tunnels and/or elevated sections greater than 5 km in length.

Operation Category 4: Vehicles for operation on underground sections, tunnels and/or elevated structures, without side evacuation available but only evacuation from the ends of the train. There are only tunnels and/or elevated sections of length not greater than 5 km.

These operation categories then have several demands on running capability and minimum average speed depending on tunnel length, how evacuation is available and length between tunnels.

There are also design categories depending on how the train is designed and together they make a classification for each vehicle and shall be specified in the procurement documents. The design categories are divided into four letters as shown below.

A: vehicles forming part of an automatic train having no emergency trained staff on board.

D: double decked vehicles.

S: sleeping and couchette vehicles.

N: all other vehicles (standard vehicles).

Part 1 also describes 5 different ignition models that are used during all performance tests within railway vehicles. These are developed to be as similar as possible to real fires. Examples of fires that the ignition models are based on are newspaper or rubbish (ignition model 1), horizontal surface of seats and floors (ignition model 2), wall and ceiling surfaces (ignition model 3), arcing in power equipment (ignition model 4), and severe fire such as luggage fire (ignition model 5) [24].

5.2.1.2 Part 6 - Fire control and management systems

This part [25] specifies technical requirements to protect the objects defined in Part 1, including requirements for fire detection, alarm systems, equipment shutdown, information and communication systems, and firefighting systems. When applicable this part focuses on the process steps; automatic detection, alarm, and action.

It tells what points that shall be taken into consideration for the verification of the system; (1) The origin of the fire; (2) the size of the fire; (3) the materials involved in the fire; (4) the nature of any detectors; (5) and the air flow. It also says that the detectors should be functionally suitable for the expected fire products, for example heat, smoke, gas or flames.

Depending on the train's category, there are different requirements on where fire detection must be assigned. The most common are:

- In combustion engine rooms
- Technical cabinets containing traction equipment
- Luggage compartments

Other places where it is often a requirement, but sometimes just a recommendation, are:

- Passenger areas
- Corridors
- Toilets
- Staff areas
- Cooking or catering area
- Other technical cabinets

Regarding the response of automatic detection systems a few requirements are listed below:

- There shall be an automatic alarm status and automatic alarm on activation of a detector; it could be local and/or remote.
- For sleeping and couchette vehicles, there shall be a local alarm given in the nearby of the activated detector in passenger areas and sleeper compartments.
- All local alarms shall also give a remote alarm either to the driver or to the control centre if no emergency trained staff is on board.
- The alarm shall be audible and/or visible depending on its type and location and it should be able to wake up a sleeping occupant.

The remainder of this part covers primarily fire extinguishing and required actions after detection of a fire. Actions include selective shut down of energy in order to avoid additional energy to the fire and to maintain function of vital systems during a fire. Depending on the train's Operation Category there are different requirements on which equipment or systems that need to be shut down and which are required to function in the event of a fire. Generally, the following equipment and systems are of prime consideration for either shut down or maintained function depending on Operation Category:

- Heating, ventilation, and air conditioning units in passenger and staff area
- Combustion engines
- Technical cabinets containing traction equipment

5.2.2 prEN 16334 Railway applications – Passenger Alarm System – System requirements

This standard has not yet been published but a draft has been issued. This standard specifies the Passenger Alarm System (PAS) fitted to the passenger carrying rolling stock. It will include 7 parts listed below:

1. General
2. The functional requirements for an alarm triggered in the driving cab
3. The communication channel between the driver and passengers or on-board staff
4. The dynamic analysis of the Passenger Alarm System
5. The requirements for the degraded modes management
6. The safety related requirements
7. Requirements for the handle and handle area

This standard is applicable to passenger trains, including tram-trains (trams that run through from an urban tramway network to main-line railway lines), high speed trains, and metros with drivers, but excluding trams, metros without driver and historical vehicles [26].

5.2.3 EN 50553 Railway applications – Requirements for running capability in case of fire on board of rolling stock

This standard [27] defines requirements of running capability under fire conditions so that a train will be able to reach a "safe area" as defined in the Safety in Railway Tunnels – SRT TSI [28]. This standard is intended to clarify and rationalise the requirements for rolling stock running capability in EN 45545 and to define specific technical measures.

5.2.4 ARGE Guideline

ARGE Guideline is the result of the Detection Technology Consortium (ARGE) with TÜV SÜD Rail GmbH as responsible editor in association with many other companies. The guideline can also be applied to comparable technical systems, e.g. buses. The guideline is divided into three parts as listed below.

- ARGE Guideline - Part 1 "Fire detection in rolling stock"
- ARGE Guideline - Part 2 "Fire fighting in Rolling Stock"
- ARGE Guideline - Part 3 "System functionality fire detection and firefighting systems in rolling stock"

ARGE Guideline focuses on personal safety. Many other standards include requirements for the installation of fire detection systems and running capability in case of fire but this guideline's focus lies only on functionality of the systems. The Guideline is accepted by the regulatory authorities of Germany (Federal Railway Authority - EBA), Austria (Federal Ministry for Transport, Innovation and Technology - BMVIT) and Switzerland (Federal Office of Transport - BAV). In addition, through the acceptance process for vehicle registration, the Guideline is being applied Europe wide and the Guideline is accepted in many countries as acknowledged code of practice. Part 1 and 3 involves fire detection and are summarised below.

5.2.4.1 Part 1: Fire detection in rolling stock

Part 1 [29] focuses on functional proof procedure for the positioning of fire detectors in passenger areas, in electrical cabinets, and in areas of combustion engines. It gives examples of response times, detector mounting positions and takes up some threshold values to be met to ensure safety considering carbon monoxide, carbon dioxide, oxygen and smoke gas temperature.

Part 1 also includes test methods for smoke detectors, mentioned below. In combustion engines areas, the guideline recommends that generally smoke should not be used as a parameter for fire detection due to the large amount of dirt there. The same applies for temperature as a parameter in passenger areas where the area is too big to get fast response on temperature.

ARGE's recommendation is that the detection system in passenger and staff areas must respond within 1 minute after the beginning of smoke release under all possible operational conditions. Noticeable is that EN 50553 prescribes a maximum detection time of 2 minutes, but in relation to the reaction and evacuation time of passengers, ARGE's experts evaluate this as too long.

To perform the assessment of detector position and selection the guideline specifies tests to verify that the installed fire detection equipment responds within the specified time. E.g. in the passenger and staff areas the fire risks are defined by possible arson or vandalism, and therefore ignition model 1 in EN 45545-1 is used, see Section 5.2.1.1. This model represents a typical ignition source due to arson or vandalism, for example newspapers and rubbish. The ignition model is a flaming source of 3 min duration and average power output of 7 kW (25-30 kW/m²).

When performing a test, the position of the test equipment should be focused in areas which:

- Are most unfavourable for quick detection of the fire.
- Permit hidden ignition.

- Can be used for storage of larger items e.g. travel baggage.

In electrical/technical areas the detection time must be less than 2 minutes and for technical areas with combustion engines the maximum time until response is set to 1 minute due to the higher risk of severe damage.

Appendix 7 in ARGE Guideline Part 1 describes the specification of the detector positioning in small installation spaces. These requirements are:

- Detector installation requirement above potential sources of ignition up to approximately 0.5 m, where combustion will be limited in enclosed and non-ventilated installation spaces.
- Detector installation requirement above potential sources of ignition up to approximately 2 m and in the ceiling area of the room, where combustion with normal thermal lift occurs in installation spaces with static ventilation.
- Detector installation requirement at the bottom flow-off edge of the air-outlet of the installation area, where combustion with deflected thermal lift occurs in strongly ventilated installation spaces.
- If the installation spaces include extensive obstructions or separating elements, the detectors for fire risk areas have to be positioned below these obstructions. In case of forced ventilation a separate positioning can possibly be omitted.

Appendix 8 in ARGE Guideline Part 1 describes the specification of the detector positioning in large installation compartments (e.g. engine rooms) and equipment installed outside (e.g. under-floor areas) by numerical fire simulation. The requirements for the areas should involve numerical fire simulations with a field model, such as FDS or Kobra 3D [29].

5.2.4.2 Part 3: System functionality fire detection and firefighting systems in rolling stock

Part 3 [30] focuses on functional proof for detection, control of system functions and the interaction between parts in the system, including alarms and fault messages. The guideline sets a number of minimum requirements for the system technology up to the system interface to the rail vehicle.

The following requirements for the alarm are mentioned:

- The fire alarm must be transmitted to the driver and/or train staff visually and acoustically.
- A local alarm has to be signalled in the passenger area when a limited noticeability of a fire by the passengers can be assumed. This means that an acoustic signal has to be provided in sleeping or couchette cars, in double-deck coaches, and in lavatory areas. Also in sleeping and couchette cars additionally a visual signal has to be provided.
- The driver has to be informed about the triggering of a fire fighting or fire extinguishing system (e.g. in connection with the shutdown of devices affected by the fire).

5.3 Aircrafts

5.3.1 ICAO – the International Civil Aviation Organization

The International Civil Aviation Organization (ICAO) was founded in 1944 to promote the safe and orderly development of international civil aviation. It is a specialised agency of the United Nations and consists of 191 member countries. They create universally accepted standards known as Standards and Recommended Practices (SARPs). These cover all technical and operational aspects of international civil aviation and consist of 19 different annexes. Annex 8 about “Airworthiness of Aircrafts” covers fire detection. (Coordinated with FARs, see below).

5.3.2 FAA – Federal Aviation Administration

Federal Aviation Administration (FAA) is part of U.S. Department of Transportation. FAA creates Federal Aviation Regulations (FARs), which coordinates with the ICAO and these regulations are often used in many countries when building an aircraft since many countries do not have their own standards.

5.3.2.1 FAR 25 – Airworthiness standards: Transport category airplanes

FARs are part of the Code of Federal Regulations (CFR) that consists of 50 titles. Title 14 is about *Aeronautics and Space* and part 25 (FAR 25) under title 14 handles airworthiness standards of transport category airplanes. Part 25 consists of subparts (A-I) and section *Fire Protection* under subpart D (Design and Construction) (§§ 25.851 - 25.869) and section *Powerplant Fire Protection* under subpart E (Powerplant) (§§ 25.1181 - 25.1207) are all about fire protection. The most interesting sections are summarised below and a more complete list of interesting chapters can be seen in Appendix C [31].

§ 25.854 Lavatory fire protection

Small airplanes do not need fire protection in the lavatory. For airplanes with a capacity of 20 passenger or more there must be a smoke detector or equivalent installed in each lavatory that provides a warning light in the cockpit, and in some cases there should also be a warning light or audible warning in the passenger cabin such that a flight attendant is alerted. Each waste bin for e.g. towels, paper or waste located within the lavatory must also be equipped with a built-in fire extinguisher. If a fire occurs here, the extinguisher must be designed to automatically discharge into the affected waste bin.

§ 25.857 Cargo compartment classification

CFR 25.857 currently describes four classifications (excluding Class D) of cargo compartments. With the exception of Class A compartments, they all require a fire detection system that will give a warning to the pilot or flight engineer station. Class A compartments are small compartments adjacent to occupied areas where a fire would be immediately discovered by a crewmember. Definitions for class A-E cargo or baggage compartments are listed below.

Class A cargo or baggage compartment is one in which:

- A fire would easily be discovered by a crewmember while at his station.
- Each part of the compartment is easily accessible in flight.

Class B cargo or baggage compartment is one in which:

- There is sufficient access in flight to enable a crewmember to effectively reach any part of the compartment with the contents of a handheld fire extinguisher.

- When the access provisions are being used, no hazardous quantity of smoke, flames or extinguishing agent, will enter any compartment occupied by the crew or passengers.
- There is a separate approved smoke detector or fire detector system to give warning at the pilot or flight engineer station.

Class C cargo or baggage compartment is one not meeting the requirements for either a class A or B compartment but in which:

- There is a separate approved smoke detector or fire detector system to give warning at the pilot or flight engineer station.
- There is an approved built-in fire extinguishing or suppression system controllable from the cockpit.
- There are means to avoid spread of hazardous quantities of smoke, flames or extinguishing agent from the compartment to any compartment occupied by the crew or passengers.
- There are means to control ventilation and drafts within the compartment so that the extinguishing agent used can control any fire that may start within the compartment.

Class D cargo compartments were removed from the CFR after an occurred accident. This class formerly relied on passive oxygen starvation and that the compartment was small and sealed enough not to threaten the airplane in the event of a fire. No fire detection or suppression systems were required (Federal Aviation Administration) [32].

Class E cargo compartment is one used only for the carriage of cargo (not baggage of passengers) and in which:

- There is a separate approved smoke or fire detector system to give warning at the pilot or flight engineer station.
- There are means to shut off the ventilating airflow to, or within, the compartment and the controls for these means are accessible to the flight crew in the crew compartment.
- There are means to exclude hazardous quantities of smoke, flames or noxious gases from the flight crew compartment.
- The required crew emergency exits are accessible under any cargo loading condition.

§ 25.858 Cargo or baggage compartment smoke or fire detection systems

If a fire detection system is needed in the cargo compartment, there must be a visual indication to the flight crew within one minute after the start of the fire. It is essential to know if the detectors are working properly during a flight and therefore the crewmembers must be allowed to check each fire detector circuit in flight. The standard also prescribes that the effectiveness of the detection system must be shown for all approved conditions and operating configurations.

In addition, flight tests are required to demonstrate that the detection system will respond to smoke or a smoke simulant in less than 1 minute [33].

§ 25.1181 Designated fire zones; regions included

A fire zone in an aircraft is typically an area or a region designed to require fire detection and/or fire extinguishing equipment and a high level of fire resistance.

§ 25.1203 Fire detector system

Each designated fire zone must have its own quick acting fire or overheat detection system. Regarding the combustion engines, turbine and tailpipe section of turbine engine installations, the detectors must be installed in locations and numbers ensuring the fire detection to be quick in those zones.

There are some criteria that need to be fulfilled regarding installation and construction of each fire detector system:

- It must resist the vibration and other loads that can occur during operation.
- If a sensor or associated wiring within a designated fire zone is serviced, there must be a way to warn the crew if the system does not continue to function as a satisfactory detection system after the service is made.
- In the event of a short circuit within a designated fire zone, there must be a way to warn the crew if the system does not continue to function as a satisfactory detection system after the short circuit.

Additionally, if there might be any oil, water, other fluids or fumes present, the fire or overheat detector should not be affected by this. The crewmembers must be allowed to check the functioning of each fire or overheat detector electric circuit in flight, and the fire or overheat detector components must be fire resistant, meaning that they should be functioning in high temperatures for a short time.

The fire or overheat detector system components belonging to a fire zone cannot pass through another fire zone, unless one of these conditions applies:

- The system is protected against the possibility of false warnings resulting from fires in zones through which the system components pass.
- Each zone involved by the system is simultaneously protected and a fire in any of the zones can be detected by the system.

§ 25.1207 Compliance

The compliance with the above mentioned requirements should be demonstrated by a full scale fire test unless otherwise specified. However, there are possibilities to combine e.g. component tests, with theoretical analysis and experiences of aircrafts with similar configurations, instead of performing a full scale fire test.

5.3.3 Joint Aviation Authorities (JAA)

The Joint Aviation Authorities (JAA) started in 1970 and was an associated body of the European Civil Aviation Conference representing the civil aviation regulatory authorities. They were developing and implementing common regulatory standards and procedures but have now given the responsibility to EASA, see Section 5.3.4.

JAA was responsible for publishing regulations governing the operations, maintenance, licensing, and certification/design standards for all classes of aircraft. These regulations were introduced to achieve common ground between the states involved. These regulations are known as Joint Aviation Requirements (JARs) [34].

5.3.4 European Aviation Safety Agency (EASA)

The European Aviation Safety Agency (EASA) is the European Union's strategy for aviation safety. Their mission is to promote common standards of safety and environmental protection in civil aviation. They started in 2003 and have now taken over the responsibility from JAA [35].

5.4 Ships

5.4.1 International Convention for the Safety of Life at Sea (SOLAS)

The SOLAS Convention regulates construction, equipment, and operation of vessels on the sea. It consists of several different chapters and especially chapter II-2 covers fire protection, fire detection and fire extinction. In this chapter Regulation 7 covers Detection and alarm. [36]

One requirement is, for example, that detection systems with only heat detectors are not permitted, unless especially appropriate. However, for detailed requirements on system performance it is in regulation 7 referred to the Fire Safety System (FSS) Code. It specifies requirements from SOLAS chapter II-2 and refers to standards and guidelines to define many of the requirements.

5.4.2 International Code for Fire Safety System (FSS Code)

It is written in the FSS Code [37] that the purpose of the code is to provide international standards of engineering specification for fire safety systems required by chapter II-2 in SOLAS.

Fire detection and alarm systems shall comply with chapters 9 and 10 of the FSS Code. Chapter 9 manages point heat detectors and smoke detectors of point type and chapter 10 manages sample extraction smoke detection systems (aspirated smoke detection systems). There are no specific demands on detection in engine compartments but some of the general demands will be summarised in the following sections.

5.4.2.1 Chapter 9, fixed fire detection and fire alarms system

In the general requirements in chapter 9 of the FSS code it is stated that any fixed fire detection and fire alarms system with manually operated call points shall be capable of immediate operation at all times. The fixed fire detection and fire alarm system shall not be used for any other purpose, except that closing of fire doors and similar function may be permitted at the control panel. The system and equipment shall be suitably designed to withstand difficult operational conditions like supply voltage variation and transient, ambient temperature changes, vibration, humidity, shock, impact, and corrosion normally encountered in ships. Furthermore, at least two power sources shall exist to power electrical equipment used for fixed fire detection and fire alarm system. One of these should be an emergency power source.

Considering detectors it is required that they shall be activated by heat, smoke or other products of combustion, flame, or any combination of these factors. Detectors that will be activated by factors of incipient fires may be considered by the Administration (the Government of the state whose flag is entitled to fly), provided that they are no less sensitive than detectors activated by products. Flame detectors shall only be used as a complement to smoke or heat detectors. All detectors should however be of a type such that they can be tested for correct operation and restored to normal surveillance without the renewal of any component.

Smoke detectors are required in stairways, corridors, and escape routes within accommodation spaces and shall be certified to give an alarm between 2-12.5% obscuration per meter ($\approx 0.09-0.58$ dB/m). Smoke detectors installed in other spaces shall activate within sensitivity limits to the satisfaction of the Administration with regards to insensitivity or oversensitivity of the detector.

Heat detectors shall be certified to activate between 54-78°C for a temperature raise less than 1 °C/minute. For faster rates of temperature rise the detector shall operate within temperature limits that will satisfy the Administration regarding avoidance of insensitivity or oversensitivity. In drying room and similar spaces, where the normal ambient temperature is high, the activation temperature may be up to 130°C, and up to 140°C in saunas.

With regards to positioning of the detectors it is required that they shall be located for optimum performance. Position close to beams and ventilation ducts where patterns of airflow could adversely affect the performance should be avoided. Positions where impact or physical damage is likely should also be avoided. The maximum spacing of detectors is shown in Table 17.

Table 17. Spacing of detectors.

Type of detector	Maximum floor area per detector [m ²]	Maximum distance apart between centres [m]	Maximum distance away from bulkheads [m]
Heat	37	9	4,5
Smoke	74	11	5,5

The Administration may require or permit different spacing than specified in Table 17 based on test data which show the characteristics of the detectors.

Electrical wiring which forms part of the system shall be so arranged as to avoid galleys, machinery spaces, and other spaces of high risk. This is to avoid damage on the electrical wiring. Exceptions could however be accepted for spaces where it is necessary with fire detection or connecting to appropriate power supply.

The activation of any detector or any manually operated call point shall start an audible and visual fire signal at the control panel and indicate the activated unit. If no manual confirmation/action has been received by the system within two minutes, an audible alarm shall be automatically sounded in the crew accommodation, service spaces, control stations, and machinery spaces. The control panel should also give an audible and visual signal in case of power loss or failure in electric circuits for the detection system.

5.4.2.2 Chapter 10, sample extraction smoke detection (aspirated smoke detection)

In the general requirements in chapter 10 of the FSS code it is stated that the system and equipment shall be suitably designed to withstand supply voltage variation and transient, ambient temperature changes, vibration, humidity, shock, impact and corrosion normally encountered in ships. The system should also be designed to avoid the possibility of ignition of a flammable gas-air mixture. As in chapter 9 it is required to provide the system with alternative power supply. The system shall also be of a type such that they can be tested for correct operation and restored to normal surveillance without the renewal of any component.

In the component requirements it is stated that the system must be certified to activate before the smoke density within the sensing chamber exceeds 6.65% obscuration per meter (≈ 0.3 dB/m). The system shall also be provided with an arrangement for

periodically purging and cleaning the pipes with compressed air. The control panel shall be able to monitor the airflow through the sampling pipes.

The sample pipes shall be a minimum of 12 mm internal diameter except when it is used together with a fixed gas fire-extinguishing system. In those cases the minimum size shall be sufficient to permit the fire-extinguishing gas to be discharged within the appropriate time. The sampling pipe arrangements shall be such that the location of the fire easily can be identified. This may be achieved by e.g. redirect the airflow in intervals and measuring the time delay until smoke is detected.

5.4.3 International Maritime Organization (IMO)

It is the International Maritime Organization that issues e.g. SOLAS and the FSS Code. IMO also issues numerous of circulars, which the FSS Code or any other Code of higher hierarchy may refer to. There are at least three circulars that cover fire detection: [38]

- MSC.1/Circ.1035 – Guidelines for the use and installation of detectors equivalent to smoke detectors
- MSC.1/Circ.1242 – Guidelines for the approval of fixed fire detection and fire alarm systems for cabin balconies
- MSC.1/Circ.1370 – Guidelines for the design, construction and testing of fixed hydrocarbon gas detection systems

Circular 1035 basically just states that the requirements in the FSS Code apply and that the detector should be equivalent to smoke detectors required by SOLAS. EN 54-7 is mentioned as an example of required level of testing.

Circular 1242 and 1370 are a little more detailed, but the requirements are functional. There are not many prescriptive formulations, with clear levels of what is accepted. Focus lies on what to consider and which type and configuration of detector to use. Circular 1370 have some additional chapters about system control, maintenance, calibration, and operating instructions, which are a little more precise.

5.5 Military applications

5.5.1 STANAG 4317

STANAG, Standardization NATO Agreement, is a set of standards defining materials, products, methods, designs, procedures, etc., for military units from NATO-members or nations cooperating with NATO. The subject of STANAG 4317 [10] is *Specification of common characteristics for fire detection and fire fighting systems for future main battle tanks* and that is of specific interest since it covers fire detection in vehicles.

STANAG 4317 relate to systems installed in the crew compartment of main battle tanks and specifies tests and requirements for environmental, reliability, safety and efficiency concerns. Some key parameters for some of the environmental tests are presented in Table 18 for comparison to the data presented in Table 14, Table 15, and Table 16. Regarding the cold and heat tests there is one additional test not mentioned in the table that simulates a climatic cycle with different temperatures and humidity. In the “operational” tests the system shall be switched on during test, while in the “storage” tests the system is switched off. Other environmental tests cover EMC, natural ageing (one year test duration) and military specific tests like ballistic shocks and radiation from nuclear explosion.

Table 18. Environmental tests parameters.

	Freq. range	Scanning	Axes	Amplitude/Acceleration	Duration
Vibration (scanning) test 1	5-500 Hz	1 octave/min	3	0,15 mm for 5<f<40 Hz 1 g for f>40 Hz	1 cycle (≈13 min) per axis
Vibration (scanning) test 2	5-500 Hz	1 octave/min	3	0,78 mm for 5<f<40 Hz 5 g for f>40 Hz	12 cycles (≈2,6 h) per axis
Vibration (resonant frequencies)	-	-	3	0,3 mm for 5<f<40 Hz 2 g for f>40 Hz	5 min if f<40 Hz 20 min if f>40 Hz
Operational:	Temperature	Duration	Storage:	Temperature	Duration
Cold	-40 °C	16 h	Cold	-55 °C	72 h
Dry heat	70 °C	16 h	Dry heat	85 °C	96 h
Humid heat (93% relative humidity)	40 °C	16 h	Humid heat (93% relative humidity)	40 °C	16 h/day in 10 days
Resistance to extraneous agents	Agents: oil, grease, fuels, sea water, salt spray, NBC decontaminating agents				

There is also a reliability test that requires that a system, which has successfully completed all environmental tests, shall be mounted on a main battle tank and achieve 200 hours of tank running time without failure. Other specifications, not tested, require the system's mean time between failures to be in excess of 2000 hours and the shelf lifetime to be at least five years. There is also a specification that maintenance tasks shall not exceed one hour in working time.

The safety specifications cover monitoring of the system, false alarms and toxicity of the extinguishing agent. The crew shall be able to remain in a closed chamber without ventilation at least five minutes after extinguishing.

For actual detection performance specifications there are very vague requirements. It only says that the reaction time must be short enough to prevent a fuel or a hydraulic fluid aerosol fire from reaching explosive combustion rates. The fire fighting system shall also extinguish such fires before the crew gets second degree burns.

5.6 Road vehicles and other transportable equipment

5.6.1 FM 5970 Heavy Duty Mobile Equipment Protection Systems

This recently launched standard [19] from FM Global in the US (see chapter 5.1.5) cover fire protection systems in heavy duty mobile equipment, such as loaders, trucks, forestry machines and mining equipment. Main focus for the performance requirements is on the suppression system, but a detection system may be a part of an approved complete system. Detection system specific requirements are limited to FM applicable detector standard(s) (see chapter 5.1.5) with one exception regarding flame detectors. If flame detectors are used for other purposes than solely supplement primary detection heat detectors, a warning must be activated when the detector lens is obscured.

However, there are several interesting general requirements for the complete system, including the detection system, which is worth mentioning. The operating temperature range shall be a minimum of -40°C to 60°C and there are several environmental tests required for the complete system. Tests that include the detection system and that are specific for the vehicle application are listed in Table 19. There are other tests not

mentioned in the table, e.g. another corrosion test, EMC-tests, etc., but those are not considered specific for the vehicle application. Regarding the “high temperature” test the standard states that “components, such as nozzles, that are exposed to the protected space shall not show significant deformation, blistering, or fracture”. However, if detection system components are included, some of them could have problems surviving 800°C.

Table 19. Summary of vehicle application specific environmental tests.

Test	Comments
Corrosion – Salt Spray	240 h exposure
High temperature	800°C for 15 min and then submerged in 15°C water (primary nozzles, but applicable to all components exposed to the protected space)
Aging tests (plastics)	100°C for 180 days, UV light and water spray cycle for 720 h
Gravel bombardment	Only components specified for mounting outside of the vehicle
Resistance to steam cleaning and pressure washing	(SAE J1455) Supplement to minimum requirement of IP65
Vibration	1.5 mm peak-to-peak, 10-60-10 Hz (0.3-10 g) in 4 min cycles for 4 h, 3 axes
Shock	5000 half-sine shocks, 10 g, 20-25 ms, 1 axis

5.6.2 AS 5062 Fire protection for mobile and transportable equipment

This Australian Standard [39] is a comprehensive standard regarding fire protection in vehicles, however very general and qualitative. A large portion covers risk analysis and risk management procedures and what is considered is everything between vehicle design, safeguards and maintenance to fire detection and suppression system, and personnel.

The requirements on the fire protection equipment are focused on the suppression system and not on the detection system, which is covered very briefly. Some examples of requirements are that the fire alarm system shall;

- rapidly detect a fire;
- initiate an alarm signal; and
- initiate safety functions.

The types and locations of detection devices shall also be in accordance with the fire risk assessment and appropriate to the specified hazards. If the detection system is a pneumatic system there are some extra requirements, e.g. that they shall be protected against accidental crimping and that there shall be means to safely release trapped pressure.

Besides this there are also some general requirements regarding e.g. documentation, design, power supply and wiring. The systems shall also be inspected periodically and replaced if exceeding its listed lifetime.

5.6.3 SBF – Swedish Fire Protection Association

The Swedish Fire Protection Association publishes regulations and norms regarding fire protection equipment and by them affected persons [40]. There are two interesting guidelines about fire detection and suppression systems in heavy vehicles and also a more general one about automatic fire alarm systems:

- SBF 127 – Guidelines for fire suppression systems on vehicles and forest machines
- SBF 128 – Guidelines for fixed automatic fire suppression systems on buses and coaches

- SBF 110 – Guidelines for fire alarm systems (*translation by the authors*)

All vehicles addressed by SBF 127 and SBF 128 are required to comply with these guidelines if they are going to be insured in Sweden.

SBF 128 addresses busses equipped for transportation of more than eight passengers and with a total weight of more than 10 tons. These vehicles shall be equipped with an automatic fire suppression system in the engine compartment and fulfil the requirements in the document. Focus is on the suppression system and just a short section covers the detection system. The requirements stated for the detection and alarm system are:

- Fast detection shall be achieved by appropriate numbers of detectors or length of detector cable.
- Risk of false alarms due to radiated heat from nearby objects must be considered.
- The serviceability should be as good as possible.
- Waterproof at least according to SS-IEC 529, IP 65 and vibration proof according to SS-IEC 68-2-36. Compliance with directive 95/54/EU with respect to EMC.
- Clearly and permanently marked.
- Flashing light and intermittent acoustical signal to the driver in case of an alarm.

Also the complete detection and suppression system have to conduct some additional tests in SS-IEC 68-2 regarding temperature variations and moisture.

For SBF 127 there is a separate document (SBF 127 B) that classifies all vehicles addressed by these guidelines. The vehicles concerned are different types of forest machines, mining machines, agricultural machines, tractors, loaders, construction equipment, etc. They are categorised into safety level 1-10, which primarily concerns the suppression capability like number and size of portable fire extinguishers and if the vehicle shall have an automatic or semi-automatic fire suppression system.

SBF 127, unlike SBF 128, covers a little more than just the automatic fire suppression system. There are e.g. requirements for the electrical system, fuel and air lines, shut-offs, heaters, and signs on the vehicle. However, the main part is about the detection and suppression systems, and this is similar to what is written in SBF 128. The requirements on the detection systems are the same as stated above, with additional requirements on the wiring of the system. The lines shall be protected against temperature variations and mechanical damage and continuously monitored to detect any failure mode.

SBF 110 states that the requirements in this document are applicable for fire alarm systems in buildings. The guidelines focus on planning, design, installation, use and maintenance of fire alarm systems in buildings and most specific requirements on the system components are referred to EN 54.

5.6.3.1 GRAMKO

The working environment committee of the mining and mineral industry in Sweden (GRAMKO) provides regulations for the fire protection of vehicles in the mining industry [41]. This document covers about the same as SBF 127 and regarding requirements on automatic fire suppression systems the document refers directly to SBF 127. According to the document all unmanned vehicles underground shall have an automatic suppression system installed, but it is recommended for all larger vehicles in the production line underground.

5.6.4 ADR-S

ADR-S [42], the Swedish version of the European Agreement Concerning the International Carriage of Dangerous Goods by Road (ADR), is published by the Swedish Civil Contingencies Agency (MSB). The document requires that vehicles transporting explosive substances and articles or that are involved in the manufacturing of explosive substances shall have an automatic suppression system installed. There are, however, no explicit requirements on the system in this document.

6 Research and studies

The public research available on fire detection in heavy vehicles is limited, and standards and regulations mainly apply to detectors in other applications, such as buildings. However, there are organisations working on or planning to work on standards and test methods for fire protection systems to be installed in engine compartments [43] and consequently one can expect more publications in the future.

Some of the difficulties that fire detections systems in engine compartments are facing are also present in other applications, meaning there has been and is research going on, but not specifically aimed at engine compartments in heavy vehicles. E.g. the effect of high rates of air-flow [44], [45], [46], [47] and the possibilities to use data from existing sensors in e.g. batteries [48] are targets for the studies.

SP Fire Research have previously performed studies regarding detections systems in heavy vehicles [49]. In that study the effects that the complex geometries and air-flow in an engine compartment may have on fire detectors performance is investigated using CFD-simulations in a compartment modelled after the mock-up used in SP Method 4912 [50]. The study uses a 300 mm × 300 mm heptane pool fire and varies the ventilation rate while looking at gas temperatures and obscuration in different locations inside the engine compartment. The results of the study showed that heat detectors are highly affected by ventilation and location and likely would not detect a fire unless its plume impinges directly on the sensor. Smoke detectors were found to be slightly less sensitive to both high air flows and position, but that their performance is indeed affected.

Kidde performed a few tests to compare different fire detection methodologies for engine compartments [51]. Their tests were performed inside a box ($1.7 \times 1.7 \times 2$ m) using three different ventilation rates and different sizes of pool fires as well as a fire from shorting a cable. The detector methodologies tested were linear heat detectors measuring average temperature along their full length or at any location, spot thermal detectors, and optical flame detectors. Their results showed that the optical flame detector was faster and had a higher success rate than the heat detectors for the pool fires, but that the linear heat detectors (placed no further than 10 mm from the shorted cable) were faster and had higher success rate than the optical flame detector when exposed to the cable fire. The ventilation rates are shown to have an impact on the efficiency of the heat detectors where they were slower to detect fires or failed to detect them when the ventilation rate was increased.

7 Conclusions

This report has provided an overview of fire detection technologies and a summary of relevant standards and research in the field: fire detection in vehicles. The work presented will be used as background information when the new standard and test method for fire detection in engine compartments of heavy duty vehicles is developed in WP6. A test method must be open for all types of detection technologies; both technologies that are used today and those that might be used in the future. The knowledge of different fire detection technologies, provided as an overview in this report, is therefore important to gain before a new test method is developed.

The part that summarises relevant standards and guidelines will be used more explicitly in the remaining work and the most important conclusions are discussed here. Typical product approval standards, such as EN 54, ISO 7240, FM 3210, UL 268, etc., are comprehensive and cover most issues. However, the tests in these standards are developed for building conditions and do not cover the extreme environments encountered in the engine compartments of heavy duty vehicles. To be valuable for vehicle application they could be adapted to include these extremes as well as complemented with application specific tests. This is partly done in a qualitative way for trains, aircrafts, and ships. The building approval standards are often referred to or used as an example of a product approval standard that could be used as a complement to the application specific requirements. However, the application requirements are often very qualitative. For ships it is stated that e.g. a fire detection system shall withstand the environment it is placed in regarding e.g. vibrations, temperature variations, and corrosion risks encountered on ships. Some application guidelines, such as the ARGE Guideline, recommend a full-scale application performance test.

There are also some standards, presented in this report, that have some quantitative requirements specific for the vehicle application. Vibrations and shocks are much more severe in a vehicle than in a building, but can also vary a lot between e.g. on-road vehicles and off-road vehicles. Systems for recreational vehicles (on-road) is in UL 217 required to withstand the vibration test configuration in 5 days instead of maximum 4 hours, as required for building applications. The test parameters are the same with maximum acceleration of 1.2 g (frequency range 10-35 Hz). STANAG 4317 (off-road) has several vibration tests, but with maximum acceleration of 5 g (frequency range 5-500 Hz) and maximum duration of about 3 hours. FM 5970 (off-road) require maximum acceleration of 10 g (frequency range 10-60 Hz) and 4 hours duration for each axis, complemented with a shock test of 5000 half-sine shocks with maximum acceleration of 10 g.

Temperature variations and humidity tests for recreational vehicles in UL 217 are modified with longer duration times and in EN 14604 they are complemented with a temperature cycle. The maximum and minimum temperatures are around 65°C and -35°C, and are only shifted slightly compared to building applications. In STANAG 4317 extreme temperatures of 85°C and -55°C are used, but during shorter times. However, in these standards the environment in the personal space in vehicles is considered. FM 5970 is more focused on the engine compartment and in this standard more extreme high temperatures are used; 100°C for 180 days (plastics) or 800°C for 15 minutes (metals).

Regarding corrosion tests, all vehicle application standards mentioned above use a salt spray test. Salt is a corrosive substance common on winter roads and is therefore important to consider for systems used in vehicles.

To sum up; test procedures from product approval standards, such as EN 54, can be used, complemented with application specific performance tests. However, requirement levels should be adapted and vehicle application standards, such as FM 5970, can be used as guidance in this work.

References

- [1] D. Nilsson och G. Holmstedt, *Kompendium i Aktiva system – Detektion Report 7030*, Lund: Department of Fire Safety Engineering. Lund University, Sweden, 2007.
- [2] R. Bukowski, *Techniques for fire detection.*, Center for Fire Research National Bureau of Standards, 1987.
- [3] C. M. & S. AB, *TS1000 Fire Protection Systems for Rolling Stock Applications.*, Transport Safety Division, Consilium, 2012.
- [4] Firefly AB, "Early fire detection with the Electronic Nose (MGD)," [Online]. Available: <http://www.firefly.se/en/solutions/electronic-nose>. [Accessed 24 August 2015].
- [5] J. Rönnblom, J. Brandt and M. Försth, "Fire Detection in Engine Compartment of Buses," SP Technical Research Institute of Sweden, SP Report 2012:54, Borås, 2012.
- [6] New York City Fire Department, "Study material for the certificate of fitness for: Inspection, cleaning & testing of smoke detectors S-78 (citywide) / F-78 (premises related)," 2012. [Online]. Available: http://www.nyc.gov/html/fdny/pdf/cof_study_material/s78_f78_st_mat.pdf. [Använd 15 October 2013].
- [7] C. Nylander, Interviewee, *Project Technical Engineer, Consilium Marine & Safety AB.* [Interview]. 18 September 2013.
- [8] The Fire Safety Advice Center, "Fire Alarm Systems," [Online]. Available: <http://www.firesafe.org.uk/fire-alarms>. [Använd 16 September 2013].
- [9] UNECE Regulation No. 107 - Rev. 3, "General construction of buses and coaches," 2011.
- [10] Military Agency for Standardization (MAS), "STANAG 4317 (Edition 2) - Specification of common characteristics for fire detection and fire fighting systems for future main battle tanks," 1996.
- [11] European Committee for Standardization (CEN), "EN 14604 - Smoke alarm devices," 2005.
- [12] Underwriters Laboratories Inc., "UL 217 (Fourth Edition) - Standard for single and multiple station smoke detectors," 1993.
- [13] European Committee for Standardization (CEN), "EN 54 - Fire detection and fire alarm systems," 2000 (EN 54-5, EN 54-7), 2002 (EN 54-10), 2006 (EN 54-20).
- [14] European Committee for Standardization (CEN), "CEN/TC 72 - Standards under development," [Online]. Available: <http://www.cen.eu/cen/Sectors/TechnicalCommitteesWorkshops/CENTechnicalCommittees/Pages/WP.aspx?param=6055&title=CEN/TC%2072>. [Accessed 13 December 2013].
- [15] ISO, the International Organization for Standardization, [Online]. Available: <http://www.iso.org/iso/home.htm>. [Accessed 13 December 2013].
- [16] ISO, the International Organization for Standardization, "ISO 7240 - Fire detection and alarm systems," 2004 (ISO 7240-15), 2007 (ISO 7240-22).
- [17] National Fire Protection Association (NFPA), "About NFPA," [Online]. Available: <http://www.nfpa.org/about-nfpa>. [Accessed 13 December 2013].
- [18] National Fire Protection Association (NFPA), *NFPA 72 - National Fire Alarm and Signaling Code*, 2013.
- [19] FM Approvals, "Approval Standards," [Online]. Available: <http://www.fmglobal.com/page.aspx?id=50030000>. [Accessed 3 September 2015].
- [20] Underwriters Laboratories (UL), "What We Do," [Online]. Available: <http://www.ul.com/global/eng/pages/aboutul/whatwedo/>. [Accessed 13 December 2013].
- [21] Underwriters Laboratories Inc., "UL 268 (Sixth Edition) - Smoke detectors for fire alarm systems," 2009.
- [22] Underwriters Laboratories Inc., "UL 268A (Fourth Edition) - Standard for smoke detectors for

- duct application," 2008.
- [23] Underwriters Laboratories Inc., "UL 521 (Seventh Edition) - Standard for heat detectors for fire protective signaling systems," 1999.
- [24] Swedish Standard Institute, "SS-EN 45545-1:2013. Railway applications - Fire protection on railway vehicles - Part 1: General," 2013.
- [25] Swedish Standard Institute, "SS-EN 45545-6:2013. Railway applications - Fire protection on railway vehicles - Part 6: Fire control and management systems," 2013.
- [26] Austrian Standards Institute, "prEN 16334:2011 - Railway applications - Passenger Alarm System - System requirements," [Online]. Available: <https://shop.austrian-standards.at/Preview.action;jsessionid=978F517B829E486051DA73504586C65B?preview=&dokkey=411914&selectedLocale=en>. [Accessed 1 October 2013].
- [27] Swedish Standard Institute, "SS-EN 50553-1. Railway applications. Requirements for running capability in case of fire on board of rolling stock," 2012.
- [28] European Railway Agency (ERA), "Safety in railway tunnels - SRT TSI," 2008.
- [29] Tüv Süd Rail GmbH, "ARGE Guideline - Part 1: Fire detection in rolling stock", [Online]. Available: <http://www.tuev-sued.de/uploads/images/1348570015346044510781/arge-guideline-part-1-fire-detection-rollig-stock-v-4.pdf>. [Accessed 9 September 2013].
- [30] Tüv Süd Rail GmbH, "ARGE Guideline - Part 3: System functionality fire detection and fire fighting systems in rolling stock", [Online]. Available: <http://www.tuev-sued.de/uploads/images/1348570105016039960398/arge-guideline-part-3-system-functionality-rollg-stock-v-2.pdf>. [Accessed 9 September 2013].
- [31] U.S. Government Printing Office, "Code of Federal Regulations, Title 14, Chapter 1, Airworthiness standards: Transport category airplanes," [Online]. Available: <http://www.ecfr.gov/cgi-bin/retrieveECFR?gp=&SID=0303b82afa1d51b2b913cb53ea84ef50&r=PART&n=14y1.0.1.3.11>. [Accessed 13 September 2013].
- [32] Federal Aviation Administration, "Lessons Learned," [Online]. Available: <http://lessonslearned.faa.gov/ValuJetDC9/ClassC-Dregulations.pdf>. [Accessed 5 November 2013].
- [33] D. Blake, "Development of a standardized fire source for aircraft cargo compartment fire detection systems," U.S. Department of Transportation, 2006.
- [34] Skybrary, "Joint Aviation Requirements," [Online]. Available: <http://www.skybrary.aero/index.php/JARs>. [Accessed 14 September 2013].
- [35] European Aviation Safety Agency, "More about EASA," [Online]. Available: <http://easa.europa.eu/more-about-EASA.php>. [Accessed 14 September 2013].
- [36] "Chapter II-2 of SOLAS: Construction - Fire Protection, Fire Detection and Fire Extinction," [Online]. Available: http://www.dft.gov.uk/mca/mcga07-home/shipsandcargoes/mcga-shipsregsandguidance/mcga-spubs/mcga-gr-solas_ii-2.htm. [Accessed 16 January 2014].
- [37] International Maritime Organisation (IMO), "FSS Code - International code for fire safety system," CPI books, UK, 2007.
- [38] "IMO-dokumentation," [Online]. Available: <http://www.transportstyrelsen.se/imo>. [Accessed 16 January 2014].
- [39] Standards Australia, "AS 5062 - Fire protection for mobile and transportable equipment," 2006.
- [40] The Swedish Fire Protection Association ("Brandskyddsföreningen"), [Online]. Available: http://www.brandskyddsforeningen.se/forlagsinformation/e-norm/alla_regelverk. [Accessed 8 April 2014].
- [41] Gruv- och mineralindustrins arbetsmiljökommitté (GRAMKO), "Regler för brandskydd och säkerhetstekniska anordningar på arbetsmaskiner/fordon inom gruvindustrin," 2010.
- [42] Myndigheten för samhällsskydd och beredskaps författningssamling (MSBFS), "ADR-S, Myndigheten för samhällsskydd och beredskaps föreskrifter om transport av farligt gods på väg

- och i terräng," Key Hedström, 2013.
- [43] J. Huczek, *Active Fire Protection for Motorcoach Fire Safety: Development of Test Apparatuses and Procedures*, Orlando: Southwest Research Institute, 2015.
- [44] J. B. Dinaburg, J. Floyd och D. T. Gottuk, "Validation of Modeling Tools for Detection Design in High Air flow Environments: Phase II – Task 2 and 3 Report: Fire Source and Detection Response Characterization," Hughes Associates, Baltimore, 2013.
- [45] J. A. Ierardi, "Characterizing the entry resistance of smoke detectors," Worcester Polytechnic Institute, 2005.
- [46] S. D. Wolin, N. L. Ryder, F. Leprince, J. A. Milke, F. W. Mowrer och J. L. Torero, "Measurements of Smoke Characteristics in HVAC Ducts," Department of Fire Protection Engineering, University of Maryland, 2001.
- [47] R. J. Roby, S. M. Olenick, W. Zhang, D. J. Carpenter, M. S. Klassen och J. L. Torero, "Smoke Detector Algorithm for Large Eddy Simulation Modeling," NIST, 2007.
- [48] M. S. Dattathreya, H. Singh and T. Meitzler, "Detection and Elimination of a Potential Fire in Engine and Battery Compartments of Hybrid Electric Vehicles," *Advances in Fuzzy Systems*, 2012.
- [49] R. Ochoterena, M. Hjohlman och M. Försth, "Detection of Fires in the Engine Compartment of Heavy Duty Vehicles, A Theoretical Study," i *SAE Technical Paper 2014-01-0423*, 2014.
- [50] SP Technical Research Institute of Sweden, "SP Method 4912," 19 September 2014. [Online]. Available: <http://www.sp.se/safebus>. [Accessed 28 October 2015].
- [51] P. Smith, A. Chattaway and J. Peoples, "A Comparison of Various Fire Detection Methodologies in Transit Vehicle Engine Compartment Fire Protection Systems," SAE International, 2012.

Appendix A: All chapters in EN 54

Published (2015-08)

- EN 54-1, Introduction
- EN 54-2, Control and indicating equipment
- EN 54-3, Fire alarm devices – Sounders
- EN 54-4, Power supply equipment
- EN 54-5, Heat detectors – Point detectors
- EN 54-7, Smoke detectors – Point detectors using scattered light, transmitted light or ionization
- EN 54-10, Flame detectors – Point detectors
- EN 54-11, Manual call points
- EN 54-12, Smoke detectors – Line detectors using an optical light beam
- EN 54-13, Compatibility assessment of system components
- EN 54-16, Voice alarm control and indicating equipment
- EN 54-17, Short-circuit isolators
- EN 54-18, Input/output devices
- EN 54-20, Aspirating smoke detectors
- EN 54-21, Alarm transmission and fault warning routing equipment
- EN 54-22, Resettable line type heat detectors
- EN 54-23, Fire alarm devices – Visual alarm devices
- EN 54-24, Components of voice alarm systems – Loudspeakers
- EN 54-25, Components using radio links
- EN 54-26, Carbon monoxide detectors – Point detectors
- EN 54-27, Duct smoke detectors
- EN 54-29, Multi-sensor fire detectors – Point detectors using a combination of smoke and heat sensors
- EN 54-30, Multi-sensor fire detectors – Point detectors using a combination of carbon monoxide and heat sensors
- EN 54-31, Multi-sensor fire detectors – Point detectors using a combination of smoke, carbon monoxide and optionally heat sensors

Under development

- FprCEN/TS 54-14, Guidelines for planning, design, installation, commissioning, use and maintenance
- FprEN 54-28, Non-resettable line type heat detectors

Appendix B: All chapters in ISO 7240

Published (2015-08)

- ISO 7240-1, General and definitions
- ISO 7240-2, Control and indicating equipment
- ISO 7240-3, Audible alarm devices
- ISO 7240-4, Power supply equipment
- ISO 7240-5, Point-type heat detectors
- ISO 7240-6, Carbon monoxide fire detectors using electro-chemical cells
- ISO 7240-7, Point-type smoke detectors using scattered light, transmitted light or ionization
- ISO 7240-8, Carbon monoxide fire detectors using an electro-chemical cell in combination with a heat sensor
- ISO 7240-9, Test fires for fire detectors
- ISO 7240-10, Point-type flame detectors
- ISO 7240-11, Manual call points
- ISO 7240-12, Line type smoke detectors using a transmitted optical beam
- ISO 7240-13, Compatibility assessment of system components
- ISO 7240-14, Design, installation, commissioning and service of fire detection and fire alarm systems in and around buildings
- ISO 7240-15, Point-type fire detectors using smoke and heat sensors
- ISO 7240-16, Sound system control and indicating equipment
- ISO 7240-17, Short-circuit isolators
- ISO 7240-18, Input/output devices
- ISO 7240-19, Design, installation, commissioning and service of sound systems for emergency purposes
- ISO 7240-20, Aspirating smoke detectors
- ISO 7240-21, Routing equipment
- ISO 7240-22, Smoke-detection equipment for ducts
- ISO 7240-23, Visual alarm devices
- ISO 7240-24, Sound-system loudspeakers
- ISO 7240-25, Components using radio transmission paths
- ISO 7240-27, Point-type fire detectors using a scattered-light, transmitted-light or ionization smoke sensor, an electrochemical-cell carbon-monoxide sensor and a heat sensor
- ISO 7240-28, Fire protection control equipment

Under development

- ISO 7240-29, Video fire detectors

Appendix C: Interesting chapters in CFR - Title 14 - Part 25

Title 14: Aeronautics and Space, Part 25 - AIRWORTHINESS STANDARDS:
TRANSPORT CATEGORY AIRPLANES

Contents

Subpart D—Design and Construction

Fire Protection

- § 25.851 Fire extinguishers
- § 25.853 Compartment interiors
- § 25.854 Lavatory fire protection
- § 25.855 Cargo or baggage compartments
- § 25.856 Thermal/Acoustic insulation materials
- § 25.857 Cargo compartment classification
- § 25.858 Cargo or baggage compartment smoke or fire detection systems
- § 25.859 Combustion heater fire protection
- § 25.863 Flammable fluid fire protection
- § 25.865 Fire protection of flight controls, engine mounts and other flight structure
- § 25.867 Fire protection: other components
- § 25.869 Fire protection: systems

Subpart E—Powerplant

Powerplant Fire Protection

- § 25.1181 Designated fire zones; regions included
- § 25.1182 Nacelle areas behind firewalls and engine pod attaching structures containing flammable fluid lines
- § 25.1183 Flammable fluid-carrying components
- § 25.1185 Flammable fluids
- § 25.1187 Drainage and ventilation of fire zones
- § 25.1189 Shutoff means
- § 25.1191 Firewalls
- § 25.1192 Engine accessory section diaphragm
- § 25.1193 Cowling and nacelle skin
- § 25.1195 Fire extinguishing systems
- § 25.1197 Fire extinguishing agents
- § 25.1199 Extinguishing agent containers
- § 25.1201 Fire extinguishing system materials
- § 25.1203 Fire detector system
- § 25.1207 Compliance

Subpart H—Electrical Wiring Interconnection Systems (EWIS)

- § 25.1713 Fire protection: EWIS
- § 25.1723 Flammable fluid fire protection: EWIS
- § 25.1731 Powerplant and APU fire detector system: EWIS
- § 25.1733 Fire detector systems, general: EWIS

SP Technical Research Institute of Sweden

Our work is concentrated on innovation and the development of value-adding technology. Using Sweden's most extensive and advanced resources for technical evaluation, measurement technology, research and development, we make an important contribution to the competitiveness and sustainable development of industry. Research is carried out in close conjunction with universities and institutes of technology, to the benefit of a customer base of about 10000 organisations, ranging from start-up companies developing new technologies or new ideas to international groups.

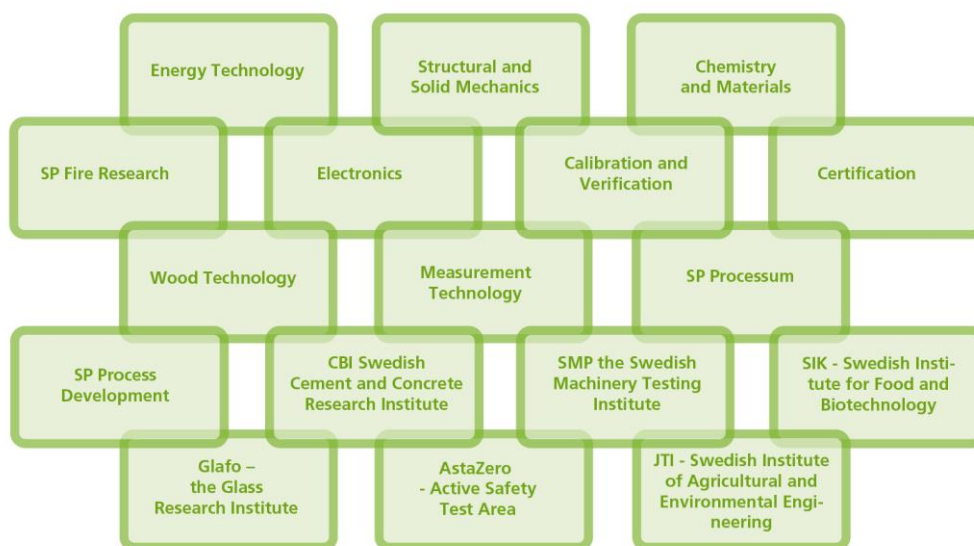

SP Technical Research Institute of Sweden

Box 857, SE-501 15 BORÅS, SWEDEN

Telephone: +46 10 516 50 00, Telefax: +46 33 13 55 02

E-mail: info@sp.se, Internet: www.sp.se

www.sp.se

SP Report 2015:68

ISBN 978-91-88001-96-2

ISSN 0284-5172

More information about publications published by SP: www.sp.se/publ