



Economic and Social Council

Distr.: General
9 January 2019

Original: English

Economic Commission for Europe

Inland Transport Committee

World Forum for Harmonization of Vehicle Regulations

Working Party on General Safety Provisions

116th session

Geneva, 1–5 April 2019

Item 7(a) of the provisional agenda

Awareness of the proximity of Vulnerable Road Users:

UN Regulation No. 46 (Devices for indirect vision)

Proposal for the 05 series of amendments to UN Regulation No. 46 (Devices for indirect vision)

Submitted by the Informal Working Group on Awareness of Vulnerable Road Users Proximity*

The text reproduced below was prepared by the experts of the Informal Working Group (IWG) on Awareness of Vulnerable Road Users Proximity (VRU-Proxi) to improve the rear field of vision. It is based on informal document GRSG-115-39, presented at the 115th session of the Working Party on General Safety Provisions (GRSG) (see report ECE/TRANS/WP.29/GRSG/94, para. 23). The modifications to the current text of UN Regulation No. 46 are marked in bold for new characters and as strikethrough for deleted ones.

* In accordance with the programme of work of the Inland Transport Committee for 2018–2019 (ECE/TRANS/274, para. 123 and ECE/TRANS/2018/21/Add.1, Cluster 3.1), the World Forum will develop, harmonize and update UN regulations to enhance the performance of vehicles. The present document is submitted in conformity with that mandate.

I. Proposal

List of contents

Annexes 10 and 11, amend to read:

"10 Calculation of the detection distance for CMS of Classes V, ~~and VI and VIII~~

11 Determination of the displayed object size for CMS of Classes V, ~~and VI and VIII"~~

Insert a reference to new Annex 13, to read:

"13 Test Methods and Safety Provisions for [Audible Warning] Systems"

Insert a new paragraph 2.1.14., to read:

"[2.1.14. "Audible Warning System" means a system as defined in paragraph 2.1.4. above, which uses audible signals, to enable the driver to detect objects in the area adjacent to the vehicle. This system shall fulfil the provisions of Annex 13.]"

Insert a new paragraph 2.4.7., to read:

"2.4.7. Class VIII: "Close-proximity rear-view device", giving the field of vision defined in paragraph 15.2.4.8."

Paragraph 5.4.3., amend to read:

"5.4.3. Additional symbol(s) I or II or/and III or/and IV or/and V or/and VI or/and VII ~~or/and VIII~~, specifying the class to which the type of device for indirect vision belongs. The additional symbol shall be placed in any convenient position in the vicinity of the circle containing the letter "E"."

Paragraph 6.1.1.2., amend to read:

"6.1.1.2. (a) Rear-view mirrors (Classes II to VII)

.....

(b) Rear-view mirrors (Class I)

In cases, where the projecting part.

(c) Rear-view mirrors (Class VIII)

Mirrors installed outside the vehicles shall comply with sub-paragraph (a) above and mirrors installed inside the vehicle shall comply with sub paragraph (b)."

Paragraph 6.1.1.3., amend to read:

"6.1.1.3. When the mirror is mounted on a plane surface, all parts, irrespective of the adjustment position of the device, including those parts remaining attached to the support after the test provided for in paragraph 6.3.2. below, which are in potential, static contact with a sphere either: ~~165 mm in diameter in the case of a Class I mirror or 100 mm in diameter in the case of a Class II to VII mirror,~~

(a) for a mirror installed inside the vehicle: 165 mm in diameter (e.g. Class I and VIII mirrors); or

(b) for a mirror installed outside the vehicle, 100 mm in diameter (e.g. Class II to VIII mirrors);

shall have a radius of curvature 'c' of not less than 2.5 mm."

Paragraphs 6.1.1.7. and 6.1.1.8., amend to read:

- "6.1.1.7. The parts of ~~Classes II to VII mirrors~~ **mirrors installed outside the vehicle (e.g. Classes II to VIII)** referred to in paragraphs 6.1.1.2. and 6.1.1.3. above which are made of a material with a Shore A hardness not exceeding 60 are exempt from the relevant provisions.
- 6.1.1.8. ~~In the case of those parts of Class I mirrors~~ **The parts of mirrors installed inside the vehicle (e.g. Class I and VIII mirrors)** which are made of a material with a Shore A hardness of less than 50 and which are mounted on a rigid support, the requirements of paragraphs 6.1.1.2. and 6.1.1.3. above shall only apply to the support."

Insert a new paragraph 6.1.2.1.7., to read:

- "6.1.2.1.7. "Close-proximity rear" view mirrors (Class VIII)**
The contours of the reflecting surface shall be of simple geometric form and its dimensions such that the mirror provides the field of vision specified in paragraph 15.2.4.8. of this Regulation."

Paragraph 6.2.1.3., amend to read:

- "6.2.1.3. The effectiveness of the CMS **and other vision supporting devices** of Classes I to ~~IV~~ **VIII** shall not be adversely affected by magnetic or electrical fields. This shall be demonstrated by compliance with the technical requirements and transitional provisions of Regulation No. 10, 04 series of amendments or any later series of amendments."

Paragraph 6.2.2.2., amend to read:

- "6.2.2.2. Functional requirements for camera-monitor devices of Classes V ~~and~~, VI **and VIII**"

Paragraph 6.3.1., amend to read:

- "6.3.1. Devices for indirect vision in Classes I to VI and Class ~~VII~~ **VIII** mirrors (having fitments identical to Class III) shall be subjected to the tests described in paragraphs 6.3.2.1. and 6.3.2.2. below. Class VII mirrors with a stem, shall be subjected to the tests described in paragraph 6.3.2.3. below."

Paragraph 6.3.2.2.7.2., amend to read:

- "6.3.2.2.7.2. Class II to ~~VII~~ **VIII** mirrors
- (a)
- (b)
- Where from the ground."

Paragraph 15.2.1.1.2., amend to read:

- "15.2.1.1.2. In the case a camera-monitor system is used for rendering (the) field(s) of vision, the relevant field(s) of vision shall be permanently visible to the driver when the ignition is on or the vehicle master control switch is activated (whichever is applicable). However, when the vehicle is moving forward at a speed above 10 km/h or backwards, the monitor or the part of the monitor intended for rendering the Class VI field of vision may be used for other information (**excluding Class VIII**). Multiple images may be used or displayed provided that the monitor has been approved in this mode.

Furthermore, in the case of a camera-monitor system intended for rendering the Class VIII field of vision, it may be such that the relevant field of vision is permanently visible to the driver only when the reverse gear is selected."

Add a new eighth column to the table in paragraph 15.2.1.1.3., to read:

"

<i>Vehicle category</i>	<i>Close-proximity rear-view Class VIII</i>
M ₁	Compulsory May be viewed using a combination of direct view and indirect vision devices (of Classes I through VI).
M ₂	Compulsory May be viewed using a combination of direct view and indirect vision devices (of Classes I through VI).
M ₃	Compulsory May be viewed using a combination of direct view and indirect vision devices (of Classes I through VI).
N ₁	Compulsory May be viewed using a combination of direct view and indirect vision devices (of Classes I through VI).
N ₂ ≤ 7.5 t	Compulsory May be viewed using a combination of direct view and indirect vision devices (of Classes I through VI).
N ₂ > 7.5 t	Compulsory May be viewed using a combination of direct view and indirect vision devices (of Classes I through VI).
N ₃	Compulsory May be viewed using a combination of direct view and indirect vision devices (of Classes I through VI).

"

Paragraph 15.2.2.2., amend to read:

- "15.2.2.2. Class II to ~~VII~~ **VIII** mirrors shall be visible through the ~~side~~ windows or through the portion of the windscreen that is swept by the windscreen wiper. Nevertheless, for design reasons, this last provision (i.e. the provisions relating the cleaned part of the windscreen) shall not apply to:
- (a) Class II to VII mirrors on the passenger side and optional exterior mirrors on the driver side of vehicles of categories M₂ and M₃;
 - (b) Class VI front-view mirrors;
 - (c) **Class VIII close-proximity rear-view mirrors.**"

Insert new paragraphs 15.2.4.8. to 15.2.4.8.3., to read (inserting a new Figure 11):

- "15.2.4.8. **Class VIII close-proximity rear-view device**
- 15.2.4.8.1. **The field of vision shall be bounded by the following planes and shall be such that the driver can see at least part of each cylindrical objects with a height of 1,000 mm and a diameter of 300 mm which is located on the ground plane at nine positions within the boundaries of the field of vision as defined in Figure 11 below:**

- (a) A transverse vertical plane through the outermost point of the rear of the vehicle;
- (b) A transverse vertical plane [3,500] mm behind the outermost point of the rear of the vehicle;
- (c) Two longitudinal vertical planes parallel to the longitudinal vertical median plane going through the outermost point of each side of the vehicle.

15.2.4.8.2. If the field of vision defined in paragraph 15.2.4.8.1. can be perceived via a combination of devices for indirect vision of other Classes or directly from the driver's looking back ocular points described in paragraph 15.2.4.8.3., it is not mandatory to equip the vehicle with a Class VIII close-proximity rear-view device. In addition, the requirement may be met using a combination of mirrors of Class VIII and other Class(es) or using an obstacle detection system.

If the field of vision defined in paragraph 15.2.4.8.1. can be perceived directly by the driver, the vertical position of rear seat headrests should be set at [the designed position assumed to use or the highest position if the headrest has multiple position settings or agreed position with the Technical Service].

Figure 11
Class VIII field of vision

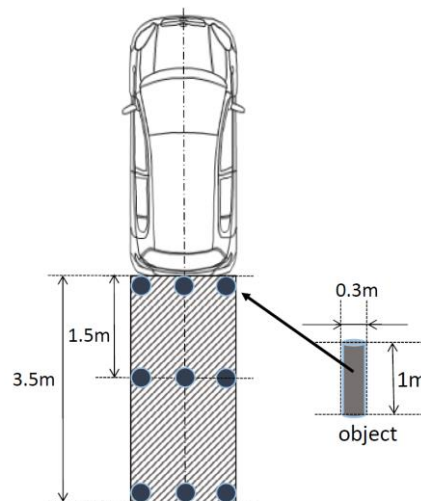

15.2.4.8.3. "The driver's looking back ocular points" means two points located at 96 mm longitudinally rearward, 158 mm horizontally inside vehicle centre and 6 mm vertically above from "the driver's ocular points" described in paragraph 12.1."

Paragraphs 15.2.4.8., 15.2.4.9. and 15.2.4.9.1. (former), renumber as paragraphs 15.2.4.9., 15.2.4.10. and 15.2.4.10.1.

Paragraph 15.2.4.9.2. (former), renumber as paragraph 15.2.4.10.2 and amend to read:

"15.2.4.10.2. Classes II, III, IV, V, ~~and~~ VI and VIII devices for indirect vision and Class VII mirrors

In the fields of vision for its special function"

Paragraph 15.2.4.10. (former), renumber as paragraph 15.2.4.11.

Paragraph 16.2., amend to read:

"16.2. Classes V, ~~and VI and VIII~~ camera-monitor devices"

Insert new paragraphs 22.18. to 22.22., to read:

- "22.18. As from the official date of entry into force of the [05] series of amendments to this Regulation, no Contracting Party applying this Regulation shall refuse an application for approval under this Regulation as amended by the [05] series of amendments for the Class VIII field of vision.
- 22.19. As from [1 September 20XX], Contracting Parties applying this Regulation shall grant approvals to a type of device for indirect vision only if the type of device meets the requirements of this Regulation as amended by the [05] series of amendments for the Class VIII field of vision.
- 22.20. As from [1 September 20XX], Contracting Parties applying this Regulation shall grant approvals to a type of vehicle with regard to the installation of devices for indirect vision only if the type of vehicle meets the requirements of this Regulation as amended by the [05] series of amendments for the Class VIII field of vision.
- 22.21. As from [1 September 20XX], Contracting Parties applying this Regulation shall not be obliged to accept approvals of a type of vehicle or type of device for indirect vision which have not been granted in accordance with the [05] series of amendments for the Class VIII field of vision to this Regulation.
- 22.22. Notwithstanding paragraph 22.21. above, type approvals granted to the preceding series of amendments to the Regulation, which are not affected by the [05] series of amendments for the Class VIII field of vision, shall remain valid and Contracting Parties applying this Regulation shall continue to accept them."

Annex 1

Item 9.1.1., amend to read:

"9.1.1. In the case of camera-monitor systems of Classes V, ~~and VI and VIII~~, the class, the detection distance [mm], contrast, luminance range, glare correction, display performance (black and white/colour) image repetition frequency, luminance reach of the monitor:..... "

Insert a new item 9.1.3., to read:

"9.1.3. In the case of an audible warning system of Classes VIII, the class, field of view, latency and rear horizontal area and detection rate:"

Annex 3, item 9., amend to read (keeping the reference to footnote ² unchanged):

"9. Brief description

Identification of the device: mirror, camera/monitor, other devices for indirect vision of Classes I, II, III, IV, V, VI, VII, VIII ²

Symbol

Annex 4, Appendix, item 2., amend to read (keeping the reference to footnote ¹ unchanged):

"2. Class(es) of mirrors and devices for indirect vision (I, II, III, IV, V, VI, VII, **VIII**, S)¹"

Annex 10, the title, amend to read:

"Calculation of the detection distance for CMS of Classes V, ~~and VI and VIII~~"

Annex 11

The title, amend to read:

"Determination of the displayed object size for CMS of Classes V, ~~and VI and VIII~~"

Paragraph 1.4., amend to read:

"1.4. Data supplied by the instructions for use

In the case of Classes V, ~~and VI and VIII~~ camera monitor devices the instructions for use shall include

..... "

Insert a new Annex 13, to read:

"Annex 13

Test Methods and Safety Provisions for [Audible Warning] Systems

1. System activation

The system shall be activated when the reverse gear is selected.

2. Driver interface and information presentation strategy

2.1. Audible information

When an object is detected in the rear horizontal area as described in paragraph 5.1. below, audible information in accordance with ISO 15006:2010 shall be given.

In presenting audible information, the distance may be identified at two or more levels. These zones may be indicated by changing the frequency of intermittent sound, and faster intermittent sound or continuous sound shall be used as the distance becomes closer.

2.2. Duration of signalling

Signalling for an object shall last as long as the object is detected and shall end when the object is no longer detected or when the system is deactivated.

To reduce the driver's discomfort, the audible signal can be automatically suspended temporarily after a certain time set by the manufacturer has elapsed, provided that the system remains to be activated. If, while the audible signal is automatically suspended temporarily, the distance to the object becomes short, the audible signal shall be automatically resumed. If the distance to the object becomes long, the audible signal may remain suspended.

3. General test conditions

The test object shall be as per paragraph 7.1. of ISO 17386:2010. During testing, the wind speed shall not exceed 1 m/s. The temperature shall be

20 ± 5°C and the humidity shall be 60 ± 25 percent. There shall be no rain or snow. The test shall be performed on a flat, dry asphalt or concrete surface. The test shall not be affected by the reflection of sound waves or electromagnetic waves from any walls, auxiliary testing equipment or any other objects in the environment.

4. Dynamic performance of object detection

4.1. Detection latency

The detection latency as measured according to paragraph 4.2. shall not exceed 0.6 s.

4.2. Detection latency test method

4.2.1. Test conditions

The testing environment and test object shall be as per paragraph 3. of this annex. The test object shall be located in the detectable grids within the rear horizontal area in paragraph 5. of this annex. The test vehicle in the initial state shall be with the detection system being activated and shall be in a parking condition. Here, parking condition means the P (park) position being selected in the case of vehicles equipped with automatic transmissions, whereas it means the neutral gear being selected and the parking brake being engaged in the case of vehicles equipped with manual transmissions.

4.2.2. Test procedures

(a) With the vehicle being in the initial state, locate the test object behind the vehicle and select the reverse gear. In the case of vehicles equipped with manual transmissions, release the parking brake after selecting the reverse gear.

(b) Measure the elapsed time (detection latency) from the moment at which the reverse gear is selected to the moment at which the audible warning starts. In the case of vehicles equipped with manual transmissions, the detection latency shall be the elapsed time from the moment at which the parking brake is released to the moment at which the audible warning starts.

5. Rear horizontal area detection rate

5.1. Monitoring area

The maximum detection distance in paragraphs 5.4.2. and 5.4.3. of ISO 17386:2010 shall be [1.0] m (Class R2).

5.2. Minimum detection rate

The minimum detection rate required for the rear horizontal area shall be as follows:

(a) 90 percent for A1 as defined in paragraph 5.4.3. of ISO 17386:2010;

(b) 87 percent for the rear-2 range in A2 as defined in paragraph 5.4.3. of ISO 17386:2010.

There shall be no undetected hole larger than a square consisting of two-by-two grids.

Here, the rear horizontal area test procedures shall be as per paragraph 7.3. of ISO 17386:2010.

- 6. Self-test capabilities and failure indication**
As per paragraph 5.5. of ISO 17386:2010.
- 7. Operation with trailers**
As per paragraph 5.6. of ISO 17386:2010."

II. Justification

This proposal is an update of informal document GRSG-115-39 on the Class VIII field of vision. Updated are additional definitions of headrest positions in the case of direct or indirect vision and the general transitional provisions taking into account the discussions during the last meeting of IWG on VRU-Proxi.
