

TEST REPORT

Hydrogen Container Performance Testing

UN GTR No. 13

Prepared For:

US Department of Transportation
National Highway Traffic Safety Administration

Contract Number: DTNH22-14-R-00063

Prepared By:

Matt Dixon, P.Eng.
Tanja Smutny, EIT

Powertech Labs Inc.
Advanced Transportation

Test Report Number: TR-00663-01-R2

December 7, 2017

TEST REPORT

No. TR-00663-01-R2

December 7, 2017



Powertech Labs Inc.
12388 88th Ave.
Surrey, BC V3W 7R7 Canada

tel: +1 (604) 590-7500

fax: +1 (604) 590-6659

www.powertechlabs.com

CONTENTS

1	ABSTRACT	2
2	INTRODUCTION.....	4
3	VERIFICATION TESTS FOR BASELINE METRICS.....	5
3.1	Baseline Initial Burst Pressure Test.....	5
3.2	Baseline Initial Pressure Cycling Test.....	8
4	VERIFICATION TESTS FOR PERFORMANCE DURABILITY (Hydraulic Sequential Tests) 11	
4.1	Test Specification	11
4.2	Test Samples.....	11
4.3	Proof Pressure Test.....	12
4.4	Drop (Impact) Test	13
4.5	Surface Damage Test.....	17
4.6	Chemical Exposure and Ambient Temperature Pressure Cycling Test.....	20
4.7	High Temperature Static Pressure Test	24
4.8	Extreme Temperature Pressure Cycling Test	26
4.9	Hydraulic Residual Pressure Test and Residual Strength Burst Test.....	30
4.10	Result Summary of Verification Test for Performance Durability (Hydraulic).....	33
5	VERIFICATION TEST FOR EXPECTED ON-ROAD PERFORMANCE (Pneumatic Sequential Tests).....	33
5.1	Test Specification	33
5.2	Test Samples.....	33
5.3	Observations	34
5.4	Proof Pressure Test.....	35
5.5	Ambient and Extreme Temperature Gas Pressure Cycling Test	36
5.6	Extreme Temperature Static Pressure Leak/Permeation Test.....	41
5.7	Residual Proof Pressure Test and Residual Strength Burst Test (Hydraulic).....	42
6	VERIFICATION TEST FOR SERVICE TERMINATING PERFORMANCE IN FIRE	45
7	VERIFICATION TEST FOR PERFORMANCE DURABILITY OF PRIMARY CLOSURES 48	
7.1	TPRD Qualification Requirements.....	48
7.2	Check Valve and Automatic Shut-off Valve Qualification Requirements.....	49
8	APPENDIX A – DATA	51

TEST REPORT

No. TR-00663-01-R2

December 7, 2017



Powertech Labs Inc.
12388 88th Ave.
Surrey, BC V3W 7R7 Canada

tel: +1 (604) 590-7500
fax: +1 (604) 590-6659
www.powertechlabs.com

1 ABSTRACT

The purpose of this test program was to provide the National Highway Traffic Safety Administration with a detailed account of testing a hydrogen storage system to the UN Global Technical Regulation No. 13 on hydrogen and fuel cell vehicles.

Containers were provided as test samples by three different container manufacturers to provide a broad range of container sizes and types. In order to simplify the testing, on-tank valves were not included with the test sample.

The containers were subjected to three performance tests from Section 5.1 in the regulation; the verification test for baseline metrics, the performance durability test and the on-road performance test. The verification test for service terminating performance in fire was not performed but the test procedure is included in this report. The verification test for closure durability is a series of component tests, which were also not performed. Some observations and insights from previously performing the component tests are listed in this report.

An overview of the test results is shown in Table 1. One container design failed the baseline cycle test and two container designs failed the performance durability test. Two container designs were subjected to the on-road performance test, which is a measure of the performance of the system under expected environmental and usage conditions over the vehicle lifetime. Both container passed this test.

Table 1. Overview of Test Program Results

UN GTR Section	Test	Results for each container manufacturer		
		1	2	3
5.1.1.1.	Baseline initial burst pressure	Pass	Pass	Pass
5.1.1.2.	Baseline initial pressure cycle life	Pass	Fail	Pass
5.1.2.4.	Ambient temperature pressure cycling	Pass	Fail	Pass
5.1.2.5.	High temperature static pressure test	Pass	n/a	Pass
5.1.2.6.	Extreme temperature pressure cycling	Pass	n/a	Fail
5.1.2.8.	Residual proof pressure and burst	Pass	n/a	n/a
5.1.3.2.	Ambient and extreme temp gas pressure cycling	Pass	n/a	Pass
5.1.3.3.	Extreme temperature static pressure permeation	Pass	n/a	Pass
5.1.3.5.	Residual proof pressure and burst	Pass	n/a	Pass



TEST REPORT

No. TR-00663-01-R2

December 7, 2017

Please note that all tests performed were documented in detail with photographs and videos of the test samples. Due to confidentiality reasons, the photographs could not be included in this test report.

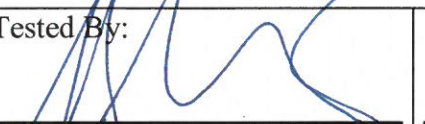
All tests outlined in this report were carried out in accordance with UN GTR ECE/TRANS/180/Add.13.

Tested By: 	Tested By: 	Approved By: 
Tanja Smutny, E.I.T Project Engineer	Matt Dixon, P.Eng. Project Manager	Philip Horacek, P.Eng. Senior Manager
Date: December 7, 2017		

TEST REPORT

No. TR-00663-01-R2

December 7, 2017

Powertech

Powertech Labs Inc.
12388 88th Ave.
Surrey, BC V3W 7R7 Canada

tel: +1 (604) 590-7500
fax: +1 (604) 590-6659
www.powertechlabs.com

2 INTRODUCTION

UN Global Technical Regulation No. 13 is an international technical specification that outlines the design and performance requirements for hydrogen fuel systems used on board light duty road vehicles and is currently being adopted by a number of countries into federal legislation.

NHTSA is pursuing rulemaking to incorporate the Global Technical Regulation No. 13 on hydrogen fuel cell vehicles (GTR No. 13) into Federal Motor Vehicle Safety Standards (FMVSSs). The GTR No. 13 lacks sufficient test procedure specifications and contains inconsistencies, which prevents NHTSA from specifying an objective and representative compliance test procedure. Powertech was contracted to perform the compressed hydrogen storage system performance tests required in Section 5.1 of the GTR No. 13 and document its procedures, configuration, and observations. This work will allow NHTSA to evaluate and verify the test requirements and the test procedures specified in GTR No. 13 as well as evaluate the feasibility of some of the performance requirements.

This report describes, in detail, the procedure, setup and results of each test as well as any observations that were made regarding the test parameters or requirements.

Each section is divided into sub-sections that cover the following:

- **Test Specification:** Section number from the GTR document
- **Test Samples:** A list of all containers required to carry out the test
- **Test Procedure:** Powertech's step-by-step test method for achieving the GTR requirements
- **Instrumentation and Setup:** Sensors and equipment required to achieve the desired test protocol including a schematic describing the location of each sensor
- **Results:** Test criteria and results for each test sample
- **Incident/Failure Report:** Details of circumstances if test sample failed
- **Observations:** Additional comments or insight from performing these tests

TEST REPORT

No. TR-00663-01-R2

December 7, 2017

3 VERIFICATION TESTS FOR BASELINE METRICS

3.1 Baseline Initial Burst Pressure Test

3.1.1 Test Specification

The testing was performed in accordance with UN GTR ECE/TRANS/180/Add.13, Section 5.1.1.1: Baseline initial burst pressure. The test procedure is outlined in Section 6.2.2.1.

3.1.2 Test Samples

The baseline initial burst pressure test was performed on nine containers in total (three containers per manufacturer) as shown in Table 2. All containers were delivered to Powertech directly from each respective manufacturer.

Table 2. Test Samples used for the Baseline Initial Burst Pressure Test

Sample number	Manufacturer number	Type	NWP (MPa)	Vol (L)	Condition
1-A	1	IV	70	30-40	new
1-B	1	IV	70	30-40	new
1-C	1	IV	70	30-40	new
2-A	2	IV	70	70-80	new
2-B	2	IV	70	70-80	new
2-C	2	IV	70	70-80	new
3-A	3	III	70	20-30	new
3-B	3	III	70	20-30	new
3-C	3	III	70	20-30	new

3.1.3 Test Procedure

Each burst test took up to 2 hours to perform with an additional hour of preparation time. Each container was also temperature conditioned for 24 hours before the burst test in order to stabilize it to the specified temperature. The detailed test procedure was performed as follows:

- 1) The container was filled with water, ensuring that no air was entrapped.
- 2) The o-ring was lubricated with o-ring lubricant and installed on the container end plug. The end plug threads were coated with an anti-galling paste and installed into the container using the manufacturer-specified installation torque.
- 3) The end plug tubing ports were capped to prevent water from draining during transportation and test setup.

TEST REPORT

No. TR-00663-01-R2

December 7, 2017

- 4) The container was placed in a temperature-controlled environment of 15-25°C for a minimum of 24 hours for temperature conditioning. The container was removed immediately prior to the burst test.
- 5) The container was placed in the burst testing containment.
- 6) The supply tubing from the high pressure pump was connected to the test container with continuous (low pressure) supply water flowing to prevent the introduction of air into the system.
- 7) The container temperature was confirmed by measuring the temperature of the container surface prior to the test.
- 8) The burst testing containment was lowered into burst pit.
- 9) The container was pressurized to failure with water. The rate of pressure increase was maintained at less than 0.35 MPa/s throughout the test.
- 10) The container was removed from burst testing bunker and photographed.
- 11) The procedure was repeated for the remaining eight containers.

3.1.4 Instrumentation and Setup

The sensors and equipment used for the baseline initial burst pressure test are shown in Table 3. The sampling rate used during data recording was 1 Hz. The pressure transducer is located near the data acquisition system approximately 30m from the test sample. An emergency pressure dump valve is also located on the same line. The container temperature is measured with a handheld digital thermometer on the container surface just prior to the test. A schematic of the test setup is shown in Figure 1.

Table 3. Baseline Burst Test Instrumentation and Equipment

Instrument/Equipment	Specification	Purpose
Pressure Transducer	0 to 275 MPa (minimum range)	Monitor container pressure
Data Acquisition System	Minimum sampling frequency of 1 Hz recommended.	Record container pressure ramp rate and burst pressure
Digital Thermometer	0°C to 50°C	Measure temperature of container prior to burst
Hydraulic Pump	Minimum output pressure of 275 MPa	Pressurize container with water

TEST REPORT

No. TR-00663-01-R2

December 7, 2017

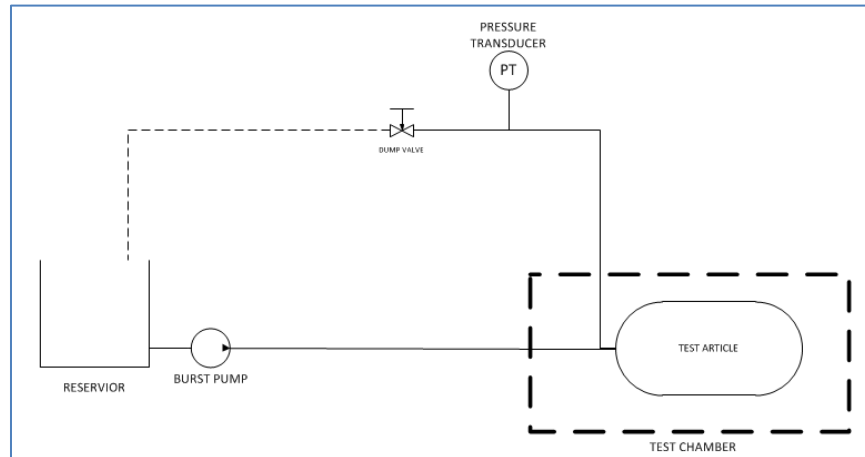

Figure 1. Baseline Burst Test Setup

3.1.5 Results

All container burst pressures were found to be within ± 10 per cent of the BPO and above the minimum burst pressure requirement (BPmin) of 157.5 MPa. The baseline burst test results are shown in Table 4. Burst pressure charts are shown in Figure 26 to Figure 34 in Appendix A.

Table 4. Baseline Burst Test Results

Sample number	Container temperature prior to burst	Burst pressure (MPa)	Average burst pressure (MPa)	BPO* (MPa)	Rupture mode
1-A	17.2°C	195.8	189.0	183.7	Complete container rupture
1-B	22.2°C	195.5			Complete container rupture
1-C	19.2°C	175.6			Complete container rupture
2-A	21.2°C	183.3	181.9	173.3	Complete container rupture
2-B	18.4°C	179.7			Complete container rupture
2-C	18.4°C	182.6			Complete container rupture
3-A	18.2°C	247.6	252.2	257.1	End fitting detached, container intact
3-B	20.0°C	247.4			End fitting detached, container intact
3-C	18.5°C	261.7			End fitting detached, container intact

*Note: The BPO values were provided by the manufacturer

3.1.6 Observations

- Since the burst test is almost always performed outdoors, a temperature range of 10°C to 40°C (similar to the NGV2 ambient temperature definition) would be more practical. The temperature range defined in the GTR is 15°C to 25°C. Loosening the temperature tolerance would also eliminate the need to temperature condition the container prior to the burst test. A 10°C to 40°C range would have no impact on the test and is supported by the OEMs.

TEST REPORT

No. TR-00663-01-R2

December 7, 2017

- If the container is dual ported with an end plug at each end, then the container can be placed schematically in series between the pressure source and the pressure measurement. Single ported containers are placed schematically in parallel with the pressure source and the pressure measurement. Both the series and parallel configurations are shown in Figure 2 as only one of the containers was dual ported.

3.2 Baseline Initial Pressure Cycling Test

3.2.1 Test Specification

The testing was performed in accordance with UN GTR ECE/TRANS/180/Add.13, Section 5.1.1.2: Baseline initial pressure cycle life. The test procedure is outlined in Section 6.2.2.2.

3.2.2 Test Samples

The baseline pressure cycle test was performed on three containers in total (one per manufacturer) as shown in Table 5. All containers were delivered to Powertech directly from the respective manufacturers.

Table 5. Test Samples used for the Baseline Initial Pressure Cycling Test

Sample number	Manufacturer number	Type	NWP (MPa)	Vol (L)	Condition
1-D	1	IV	70	30-40	new
2-D	2	IV	70	70-80	new
3-D	3	III	70	20-30	new

3.2.3 Test Procedure

The test duration with the given container volumes was 6 days. Depending on container size, this test can typically be conducted in 4 -10 days. The detailed test procedure was as follows:

- 1) The containers were filled with water ensuring that no air was entrapped.
- 2) The end plug o-rings were lubricated with o-ring lubricant and installed on the container end plugs. The end plug threads were coated with an anti-galling paste and installed into the containers using the manufacturer-specified installation torque.
- 3) The end plug tubing ports were capped to prevent water from draining during transportation and test setup.
- 4) The containers were installed into the ambient cycling containment and connected to the pressurization equipment. The supply tubing from the pump was connected to the test containers with continuous low pressure supply water flowing to prevent the introduction of air into the system.

TEST REPORT

No. TR-00663-01-R2

December 7, 2017

- 5) The containers were pressure cycled from 2 (± 1) MPa to greater than 1.25 x NWP (87.5 MPa) for 22,000 cycles or until failure with 25 (± 15) °C water. The duration of each cycle exceeded 6 seconds.
- 6) After test completion, the containers were removed from the chamber and drained of water.

3.2.4 Instrumentation and Setup

The sensors and equipment used for the pressure cycling test are shown in Table 6. The pressure transducer was located near the hydraulic pump approximately 15m from the test sample. It was connected to the outlet of the first container as this was the only dual ported container being tested.

The fluid temperature was measured by an in-line thermocouple approximately 5 cm away from the container inlet. The container skin temperature was measured on the outer hoop surface in the center of the container length. The skin temperature was only measured on the first container due to the similarities of the system as a whole. The chamber temperature was measured in the air approximately 10cm above the containers.

A schematic of the test setup is shown in Figure 2.

All sensors were monitored by a data acquisition system and recorded as maximum and minimum values for each cycle.

Table 6. Baseline Initial Pressure Cycling Test Instrumentation and Equipment

Instrument/Equipment	Specification	Purpose
Pressure Transducer	0 to 90 MPa (minimum range)	Monitor container pressure
Temperature Sensor	0 to 50°C (minimum range) e.g. - thermocouple	Measure fluid, skin and chamber temperatures
Data Acquisition System	Minimum sampling frequency recommended 10 Hz.	Record container pressure, fluid, skin and chamber temperatures
Hydraulic Pump	Minimum output pressure capability of 90 MPa	Pressurize container with water

TEST REPORT

No. TR-00663-01-R2

December 7, 2017

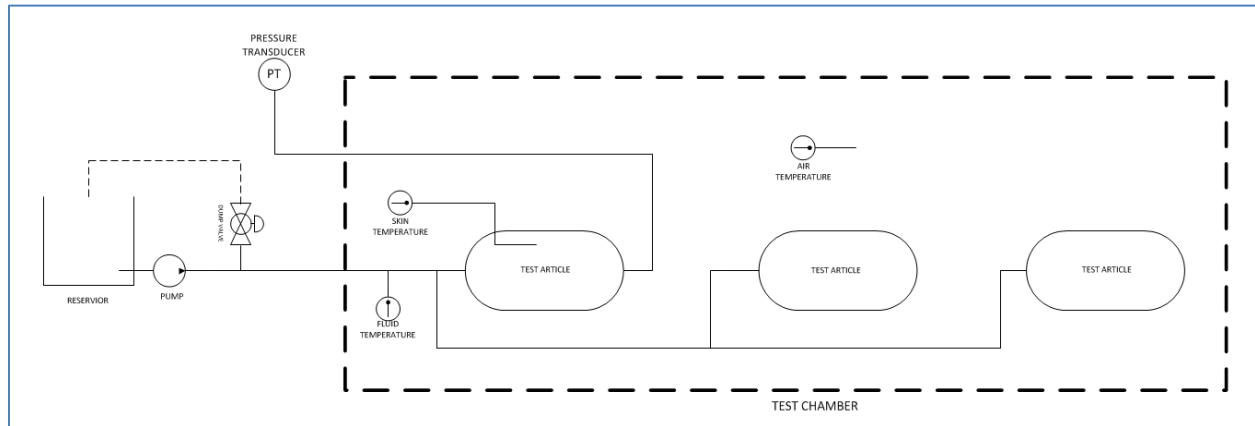

Figure 2. Baseline Initial Pressure Cycling Test Setup

3.2.5 Results

Early into the baseline pressure cycle test, after 1,773 pressure cycles, container 2-D started to leak at the sidewall and was removed from the chamber. The pressure cycling was then continued with the remaining containers. Further into the test, at cycle 10,883, container 3-D started to leak at the sidewall as well and was removed from the chamber. The test was completed to 22,000 cycles with container 1-D. A summary of the results is shown in Table 7.

Note that container 3-D did not rupture at 10,883 cycles and therefore met the requirement of 7,500 cycles without leak and 22,000 cycles without burst.

As each container was removed from the test chamber, the cycle time decreased due to the reduced volume requiring pressurization. Figure 35 in Appendix A shows a sample graph of a typical ambient cycling pressure profile. The data in the graph is from the ambient cycle test during the hydraulic sequence and was recorded when all three containers were pressure cycled together. It is mentioned here for reference only.

Table 7. Baseline Initial Pressure Cycling Test Results

Sample number	Cycle rate prior to cycle 1,773	Cycle rate from cycle 1,773 to 10,883	Cycle rate from cycle 10,883 to 22,000	Pressure cycles completed	Comments
1-D	2.0 cycles/min	3.8 cycles/min	6.5 cycles/min	22,000	No leak or rupture
2-D	2.0 cycles/min	-	-	1,773	Leak at sidewall after 1,773 cycles, container removed
3-D	2.0 cycles/min	3.8 cycles/min	-	10,883	Leak at sidewall after 10,883 cycles, container removed

TEST REPORT

No. TR-00663-01-R2

December 7, 2017

Powertech

Powertech Labs Inc.
12388 88th Ave.
Surrey, BC V3W 7R7 Canada

tel: +1 (604) 590-7500
fax: +1 (604) 590-6659
www.powertechlabs.com

3.2.6 Observations

- The temperature range defined in the GTR is 15°C to 25°C. A temperature range of 10°C to 40°C (similar to the NGV2 ambient temperature definition) would be more practical for the ambient pressure cycling test and would have no negative impact on the test.
- If the container is dual ported with an end plug at each end, then the container can be placed schematically in series between the pressure source and the pressure measurement. Single ported containers are placed schematically in parallel with the pressure source and the pressure measurement. Both the series and parallel configurations are shown in Figure 2 as only one of the containers was dual ported.

4 VERIFICATION TESTS FOR PERFORMANCE DURABILITY (Hydraulic Sequential Tests)

The total number of hydraulic pressure cycles to simulate a 15 year service life without leakage was set by the client at 7,500 cycles, of which 60% were performed at ambient temperature, 20% were performed at hot temperature and 20% were performed at cold temperature. Each container was subjected to the entire test sequence in the specified order.

4.1 Test Specification

The testing was performed in accordance with UN GTR ECE/TRANS/180/Add.13, Section 5.1.2: Verification tests for performance durability (hydraulic sequential tests), which contains the following test sequence:

- Proof pressure test (para. 5.1.2.1 and 6.2.3.1)
- Drop (impact) test (para. 5.1.2.2 and 6.2.3.2)
- Surface damage test (para. 5.1.2.3 and 6.2.3.3)
- Chemical exposure and ambient-temperature pressure cycling test (para. 5.1.2.4 and 6.2.3.4)
- High temperature static pressure test (para. 5.1.2.5 and 6.2.3.5)
- Extreme temperature pressure cycling test (para. 5.1.2.6 and 6.2.2.2)
- Hydraulic residual pressure test (para. 5.1.2.7 and 6.2.3.1)
- Residual strength burst test (para. 5.1.2.8 and 6.2.2.1)

4.2 Test Samples

The hydraulic sequential test was performed on three containers in total (one per manufacturer). The sample number and container details are shown in Table 8.

TEST REPORT

No. TR-00663-01-R2

December 7, 2017

Table 8. Test Samples used for the Hydraulic Sequential Tests

Sample number	Manufacturer number	Type	NWP (MPa)	Vol (L)	Condition
1-E	1	IV	70	30-40	Proof tested
2-E	2	IV	70	70-80	Proof tested
3-E	3	III	70	20-30	Proof tested

4.3 Proof Pressure Test

4.3.1 Test Specification

The proof pressure test was performed by the container manufacturer. The test is as per UN GTR ECE/TRANS/180/Add.13, Section 5.1.3.1: Proof pressure test. The test procedure is outlined in Section 6.2.3.1.

4.3.2 Test Procedure

The proof pressure test was performed by the container manufacturer. An example test procedure is outlined here for reference. The proof pressure test typically takes 2 hours with 24 hours of prep time. The containers are tested separately. The detailed test procedure is as follows.

- 1) The container is filled with water ensuring no air is entrapped.
- 2) The end plug o-ring is lubricated with o-ring lubricant and installed on the container end plug. The end plug threads are coated with an anti-galling paste and installed into the container using the manufacturer-specified installation torque.
- 3) The end plug tubing ports are capped to prevent water from draining during transportation and test setup.
- 4) The container is installed into the burst testing facility and connected to the pressurization equipment.
- 5) The container is pressured to greater than $1.5 \times \text{NWP}$ (105 MPa) for 30 seconds.
- 6) After test completion, the container is removed from the chamber and drained of water.

4.3.3 Instrumentation and Setup

The sensors and equipment used for the proof pressure test are shown in Table 9. The pressure transducer is located near the hydraulic pump approximately 15m away from the test sample. The pressure transducer readout is recorded by a data acquisition system at a sampling rate of 1Hz. A schematic of the test setup is shown in Figure 3.

TEST REPORT

No. TR-00663-01-R2

December 7, 2017

Table 9. Proof Pressure Test Instrumentation and Equipment

Instrument/Equipment	Specification	Purpose
Pressure Transducer	0 to 110 MPa (minimum range)	Monitor container pressure
Hydraulic Pump	Minimum output pressure capability of 110 MPa	Pressurize container with water

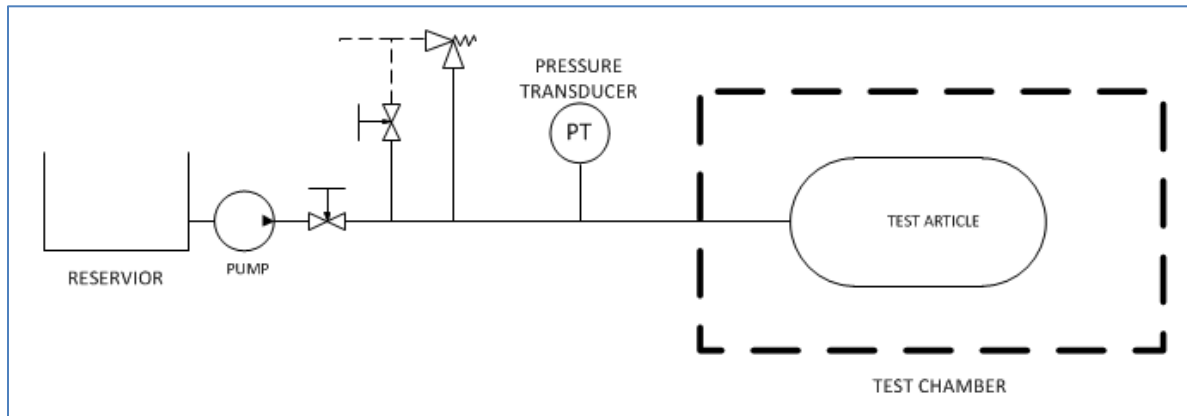

Figure 3. Proof Pressure Test Setup

4.3.4 Results

The proof test was completed by the manufacturer prior to delivery of the container to Powertech.

4.3.5 Observations

- The proof pressure test is typically performed by the manufacturer as part of the general manufacturing process. It is expected that the manufacturer will notify the test lab if the proof test was not performed. A record of the test is not typically required but can be requested from the manufacturer if necessary.

4.4 Drop (Impact) Test

4.4.1 Test Specification

The testing was performed in accordance with UN GTR ECE/TRANS/180/Add.13, Section 5.1.2.2: Drop (impact) test. The test procedure is outlined in Section 6.2.3.2.

December 7, 2017

4.4.2 Test Procedure

The duration of the drop test was 1 day including setup. The detailed test procedure for the complete drop sequence was as follows. Note that only the 45° angle drop sequence was conducted as part of this program.

- 1) The container end plugs were not installed for this test, although end plugs are sometimes used to position the container for the test orientation and to protect the threads and sealing surfaces.
- 2) The empty container was placed on a scale to determine mass of the container
- 3) The container was secured to an electrically actuated drop hook with slings or rope appropriate for the weight and nature of the test. The slings were secured to the forks of a forklift and positioned at the following angles and heights as measured with a tape measure and bubble level.
 - a. In the horizontal orientation at a height of 1.8 m as measured from the impact surface to the bottom surface of the container
 - b. In the vertical orientation with the ported end facing upward at a height calculated by the following formula but not exceeding a maximum height of 1.8 m, as measured from the impact surface to the bottom surface of the container:

$$h = \frac{E}{mg}, \text{ where } E = 488 \text{ J} \quad (1)$$

- c. In the vertical orientation with the ported end facing downward (not required for symmetrical containers), at a height calculated by formula (1) but not exceeding a maximum height of 1.8 m, as measured from the impact surface to the bottom surface of the container.
 - d. 45° angle with the ported end facing down and center of gravity at 1.8m above the ground. If the lowest point of the container is <0.6m above the ground, the drop angle is changed such that the minimum height is 0.6m and the center of gravity is at 1.8m.
- 4) After the container was steadied, the drop hook was activated with a foot pedal. The impact surface was a smooth, horizontal concrete surface.
- 5) The drop sequences were recorded on video camera
- 6) After each drop, the impacted surfaces were marked on the container and the impact sequence was noted.

4.4.3 Instrumentation and Setup

The sensors and equipment used for the drop test are shown in Table 10. The height of the container is measured with a tape measure. The container angle is confirmed with a spirit level. A photo of a typical drop test setup for a 45° drop is shown in Figure 4.

TEST REPORT

No. TR-00663-01-R2

December 7, 2017

Table 10. Drop Test Instrumentation and Equipment

Instrument/Equipment	Specification	Purpose
Weigh scale, load cell	Range dependent upon container mass	Measure mass of container
Distance Measurement	0 to 2 m (minimum range)	Measure drop height
Spirit Level	With Horizontal, Vertical, and 45° Vials	Measure container angle
Quick release hook	-	Initiate drop



Figure 4: Drop Test Setup

4.4.4 Results

Each container was subjected to the 45° drop test only as this direction was determined to be the most severe. The results of the test are shown in Table 11. An example of a typical primary impact area on the container dome during the 45° drop test is shown in Figure 5.

TEST REPORT

No. TR-00663-01-R2

December 7, 2017

Table 11. Drop Test Results

Sample number	Height	Drop Angle	Impact areas
1-E	1.8 m	45°	First Impact: Front Dome Second Impact: Rear Dome
2-E			Third Impact: Rear End Boss Fourth Impact: Hoop Area
3-E			First Impact: Front Dome Second Impact: Rear Dome Third Impact: Front Dome Fourth Impact: Rear Dome

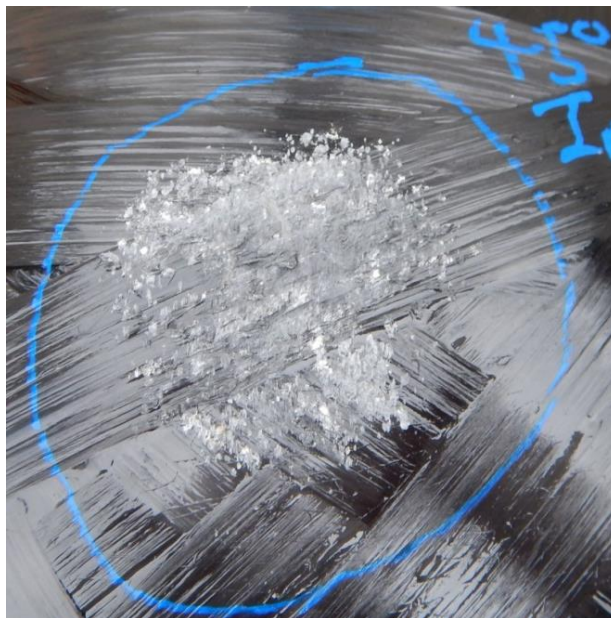

Figure 5. Primary impact area on dome of container 1-E

4.4.5 Observations

- Only the 45° drop sequence was performed on each container as it was determined to be the most severe and the most applicable for this particular test.
- The GTR requires the test to be performed at ambient temperature but there is no ambient temperature definition. Ambient temperature is presumed to be 20 (±5) °C. The ambient temperature was not recorded during this test as the test is performed outside and requires a fair amount of set up time, during which, a pre-conditioned container could change temperature by more than ±5 °C. A 10°C to 40°C temperature range would be more practical for this test.

TEST REPORT

No. TR-00663-01-R2

December 7, 2017

4.5 Surface Damage Test

4.5.1 Test Specification

The testing was performed in accordance with UN GTR ECE/TRANS/180/Add.13, Section 5.1.2.3: Surface damage test. The test procedure is outlined in Section 6.2.3.3.

4.5.2 Test Procedure

The duration of the surface damage test was 3 days. No container end plugs were installed for this test and the container was not pressurized. The detailed test procedure was as follows:

- 1) Two flaws were cut in the longitudinal direction of the container using a saw and a small abrasive cutting disc.
 - a. First flaw was a minimum of 25.0 mm long and 1.25 mm deep
 - b. Second flaw was a minimum of 200 mm long and 0.75 mm deep
- 2) The five non-overlapping pendulum impact sections were outlined on the container surface.
- 3) The marked container was then conditioned in a thermal chamber to -40°C for a minimum of 12 hours.
- 4) The container was removed from the cold chamber, restrained and impacted at each marked area with an impact energy of 30J within 30 minutes of removal from the chamber.

4.5.3 Instrumentation and Setup

The sensors and equipment used for the surface damage test are shown in Table 12. During the test, the device was positioned such that the pendulum impacted the container at a 90° angle. A photo of the pendulum machine and a close-up image of the pendulum head are shown in Figure 6 and Figure 7 respectively.

Table 12. Surface Damage Test Instrumentation and Equipment

Instrument/Equipment	Specification	Purpose
Caliper	0 to 200mm (minimum range)	Measure flaw length and depth
Pendulum Impact Device	Minimum capacity of 30 J	Impact container
Cutting tool	Saw with abrasive disk	Cut flaws on container surface

TEST REPORT

No. TR-00663-01-R2

December 7, 2017



Figure 6. Image of pendulum machine



Figure 7. Pendulum head

4.5.4 Results

All three containers were subjected to the surface damage test. The conditioning times at -40°C prior to the impact test are shown in Table 13. An image of the two flaws cut into the container surface is shown in Figure 8. Images of container 2-E prior to and after the pendulum impact are shown in Figure 9 and Figure 10.

TEST REPORT

No. TR-00663-01-R2

December 7, 2017

Table 13. Surface Damage Test Results

Sample number	Conditioning time at -40°C	Time from conditioning to impact
1-E	17 hrs	Less than 30 minutes
2-E	16 hrs	Less than 30 minutes
3-E	16.5 hrs	Less than 30 minutes

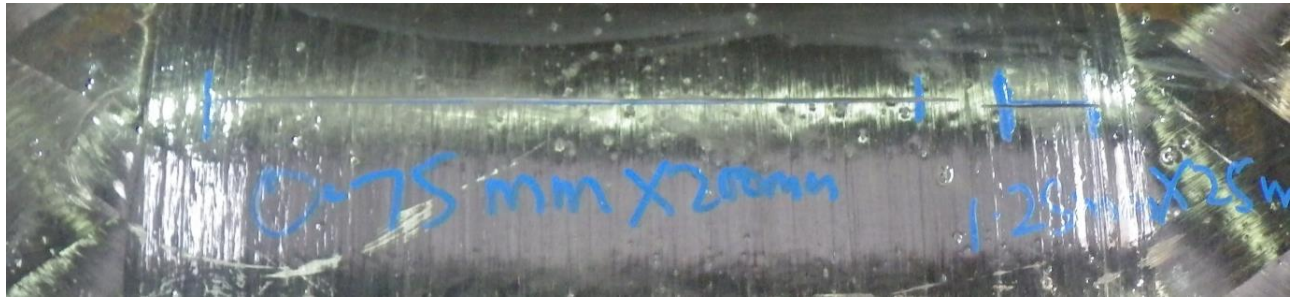

Figure 8. Flaws cut into container 1-E



Figure 9. Container 2-E prior to pendulum impact

TEST REPORT

No. TR-00663-01-R2

December 7, 2017



Figure 10. Container 2-E after pendulum impact

4.5.5 Observations

- No time duration is specified in the GTR between removal of the container from the -40°C environmental chamber and the time of impact. The 30 minute maximum time window between the temperature conditioning and the impact test stated in the test procedure is a self-imposed requirement. The 30 minutes covers the time it takes to restrain the container and position the pendulum.

4.6 Chemical Exposure and Ambient Temperature Pressure Cycling Test

4.6.1 Test Specification

The testing was performed in accordance with UN GTR ECE/TRANS/180/Add.13, Section 5.1.2.4: Chemical exposure and ambient-temperature pressure cycling test. The test procedure is outlined in Section 6.2.3.4.

4.6.2 Test Procedure

The duration of the chemical exposure and ambient pressure cycling test was 2 weeks. The detailed test procedure was as follows.

- 1) The containers were filled with water ensuring that no air was entrapped.

TEST REPORT

No. TR-00663-01-R2

December 7, 2017

Powertech

Powertech Labs Inc.
12388 88th Ave.
Surrey, BC V3W 7R7 Canada

tel: +1 (604) 590-7500

fax: +1 (604) 590-6659

www.powertechlabs.com

- 2) The end plug o-rings were lubricated with o-ring lubricant and installed on the container end plugs. The end plug threads were coated with an anti-galling paste and installed into the containers using the manufacturer-specified installation torque.
- 3) The end plug tubing ports were capped to prevent water from draining during transportation and test setup.
- 4) The containers were installed into the ambient cycling containment and connected to the pressurization equipment. The supply tubing from the pump was connected to the test containers with continuous low pressure supply water flowing to prevent the introduction of air into the system.
- 5) The following five corrosive solutions were applied to the five areas of pendulum impact:
 - a. 19% sulfuric acid
 - b. 25% sodium hydroxide
 - c. 5/95% methanol/gasoline as per ASTM D4814 M5 fuel
 - d. 28% ammonium nitrate
 - e. 50% by volume methanol aqueous solution
- 6) Wool pads soaked in the test fluids were placed on top of each area. The areas were then covered with plastic to prevent evaporation of the test solutions.
- 7) The containers were pressurized to greater than $1.25 \times \text{NWP}$ at $25^{\circ}\text{C} \pm 15^{\circ}\text{C}$ and held at pressure for 48 hours.
- 8) The containers were then pressure cycled from $2 (\pm 1) \text{ MPa}$ to greater than $1.25 \times \text{NWP}$ (87.5 MPa) for 4,500 pressure cycles at $25^{\circ}\text{C} \pm 15^{\circ}\text{C}$
- 9) Prior to the last 10 cycles the wool pads and chemicals were removed and the surface of the containers was rinsed with water
- 10) The containers were then pressure cycled from $2 (\pm 1) \text{ MPa}$ to greater than $1.5 \times \text{NWP}$ at $25^{\circ}\text{C} \pm 15^{\circ}\text{C}$ for the remaining 10 cycles
- 11) After test completion, the containers were removed from the chamber and drained of water.

4.6.3 Instrumentation and Setup

The sensors and equipment used for the pressure cycle test are shown in Table 14. The pressure transducer was located near the hydraulic pump approximately 15m from the test sample. It was connected to the outlet of the first container as this was the only dual ported container being tested.

The fluid temperature was measured by an in-line thermocouple approximately 5 cm away from the container inlet. The container skin temperature was measured on the outer hoop surface in the center of the container length. The skin temperature was only measured on the first container due to the similarities of the system as a whole. The chamber temperature was measured in the air approximately 10cm above the containers. All sensors were monitored by a data acquisition system and recorded as maximum and minimum values for each cycle.

A schematic of the test setup is shown in Figure 11.

TEST REPORT

No. TR-00663-01-R2

December 7, 2017

Table 14. Chemical Exposure and Ambient Pressure Cycling Test Instrumentation and Equipment

Instrument/Equipment	Specification	Purpose
Pressure Transducer	0 to 90 MPa (minimum range)	Monitor container pressure
Temperature Sensor	0 to 50°C (minimum range) e.g. - thermocouple	Measure fluid, skin and chamber temperatures
Data Acquisition System	Minimum sampling frequency recommended 10 Hz.	Record container pressure, fluid, skin and chamber temperatures
Hydraulic Pump	Minimum output pressure capability of 90 MPa	Pressurize container with water

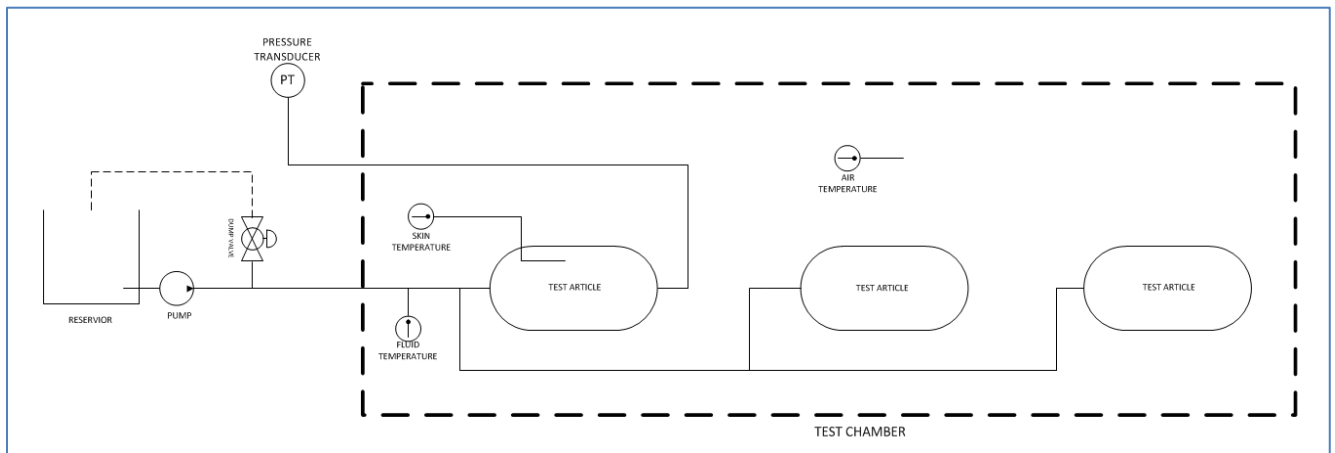

Figure 11. Chemical Exposure and Ambient Temperature Pressure Cycling Test Setup

4.6.4 Results

All three containers were subjected to the chemical exposure and ambient temperature pressure cycling test. The test results including cycling rates are shown in Table 15. Figure 36 in Appendix A shows the maximum and minimum temperatures recorded during pressure cycling to 1.25 x NWP. Figure 37 in Appendix A shows the maximum and minimum temperatures recorded during the final 10 cycles to 1.5 x NWP.

An image of container 1-E after the chemicals were applied is shown in Figure 12.

After 294 pressure cycles, the test was stopped because of a leak detection. Upon further inspection it was confirmed that container 2-E was leaking from the container dome. It was removed from the test chamber and pressure cycling continued until containers 1-E and 3-E completed the remaining pressure cycles.

TEST REPORT

No. TR-00663-01-R2

December 7, 2017

Table 15. Chemical Exposure and Ambient Temperature Pressure Cycling Test Results

Sample number	Pressure during hold	Hold Time	Cycle rate prior to cycle 294	Cycle rate after cycle 294	Cycles completed	Cycle rate during final 10 cycles
1-E	88.3 MPa	48 hours	1.8 cycles/min	4.6 cycles/min	4,500	4.0 cycles/min
2-E	88.3 MPa	48 hours	1.8 cycles/min	-	294	-
3-E	88.3 MPa	48 hours	1.8 cycles/min	4.6 cycles/min	4,500	4.0 cycles/min

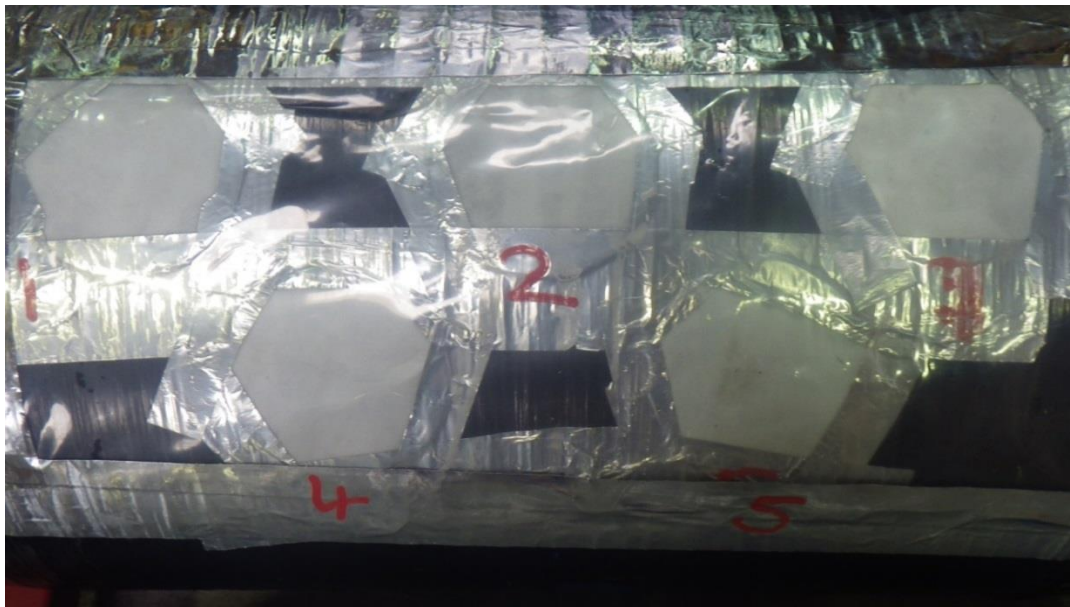

Figure 12. Container 1-E after chemical application

4.6.5 Incident/Failure Report

Container 2-E did not pass the ambient pressure cycling test. Details of the failure are shown in Table 16. An image of the leak is shown in Figure 13.

Table 16. Chemical Exposure and Ambient Temperature Pressure Cycling Test Failure Report

Sample number	Where failure occurred	When failure occurred	Evidence of failure	Description of failure
2-E	Ambient pressure cycle chamber	After 294 pressure cycles. September 29, 2015.	System could not build pressure fast enough. Visual inspection and pressure test.	Leak visible on container dome area.

TEST REPORT

No. TR-00663-01-R2

December 7, 2017

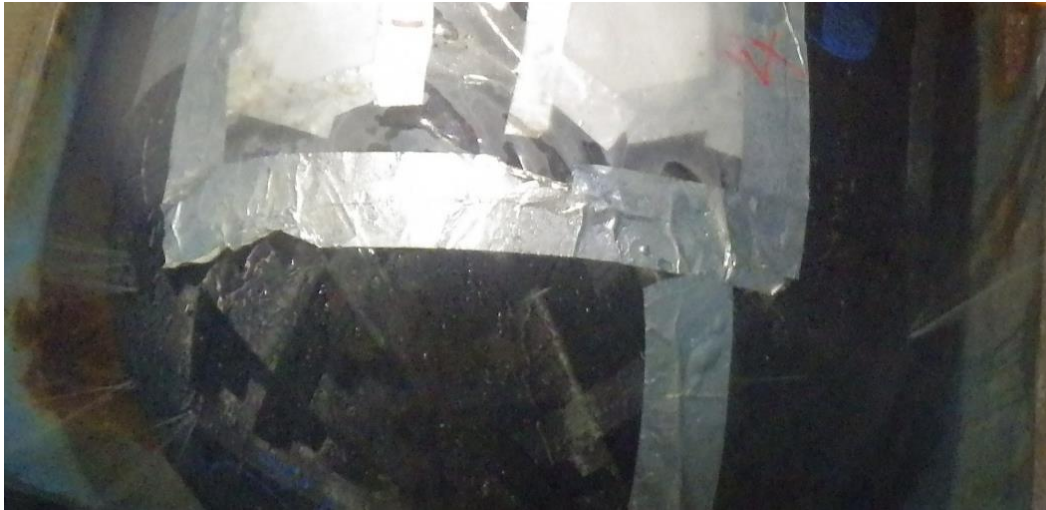

Figure 13. Leakage from container 2-E during the pressure cycling test

4.6.6 Observations

- The temperature range defined in the GTR is 15°C to 25°C. A temperature range of 10°C to 40°C (similar to the NGV2 ambient temperature definition) would be more practical for the ambient pressure cycling test and would have no negative impact on the test.

4.7 High Temperature Static Pressure Test

4.7.1 Test Specification

The testing was performed in accordance with UN GTR ECE/TRANS/180/Add.13, Section 5.1.2.5: High temperature static pressure test. The test procedure is outlined in Section 6.2.3.5.

4.7.2 Test Procedure

The duration of the high temperature static pressure test was 7 weeks including setup. The detailed test procedure was as follows:

- 1) The containers, which were still filled with test fluid from the previous test, were placed inside an environmentally controlled test chamber.
- 2) The containers were conditioned to a minimum of 85°C and pressurized to a minimum of 1.25 x NWP
- 3) The containers were held at these conditions for 1,000 hours. Temperature and pressure were regularly monitored and adjusted as necessary.
- 4) The containers were then depressurized and removed from the chamber.

TEST REPORT

No. TR-00663-01-R2

December 7, 2017

- 5) The fluid was drained from the containers in preparation for the cold pressure cycling sequence.

4.7.3 Instrumentation and Setup

The sensors and equipment used for the high temperature static pressure test are shown in Table 17. The pressure transducer is located outside approximately 5 feet away from the chamber. The chamber temperature is monitored in the chamber at approximately mid-chamber height. The pump is located approximately 10 feet from the chamber and is manually activated if the pressure of the containers decreases. The temperature and pressure of the containers are recorded manually once per day. A schematic of the test setup is shown in Figure 14.

Table 17. High Temperature Static Pressure Test Instrumentation and Equipment

Instrument/Equipment	Specification	Purpose
Pressure Transducer	0 to 90 MPa (minimum range)	Measure container pressure
Temperature Sensor	0 to 100°C (minimum range)	Measure chamber temperature
Pump	Minimum output pressure capability of 90 MPa	Pressurize container
Thermal Chamber	Minimum capability of 85°C	Provide high temperature environment, containment

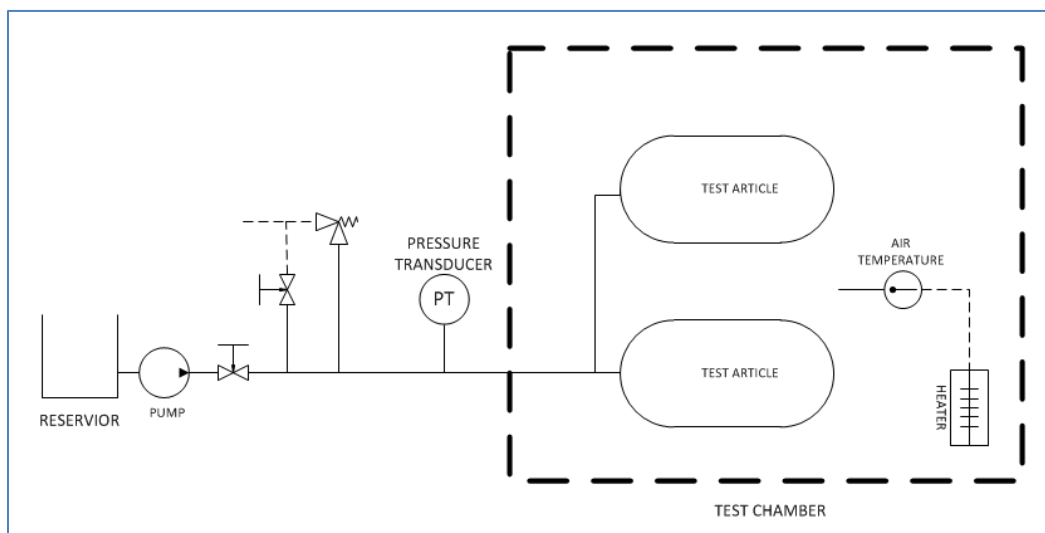

Figure 14. High Temperature Static Pressure Test Setup

4.7.4 Results

The high temperature static pressure test was performed on containers 1-E and 3-E as container 2-E had already failed the sequence during the ambient cycle test. The test results are shown in Table 18.

TEST REPORT

No. TR-00663-01-R2

December 7, 2017

Figure 38 in Appendix A shows the recorded temperature and pressure data. Note that the controller on the conditioning chamber was set to 85°C with a 2°C deadband. This caused the temperature to vary from 83°C to 85°C.

Table 18. High Temperature Static Pressure Test Results

Sample number	Initial pressure	Test duration	Final pressure	Initial temperature	Final temperature
1-E	88.3 MPa	1008 hrs	88.3 MPa	85°C	84°C
2-E	-	-	-	-	-
3-E	88.3 MPa	1008 hrs	88.3 MPa	85°C	84°C

4.7.5 Observations

- The pressure inside the containers can drop during the test due to slow creep expansion of the container. To counteract this, the containers are connected to a pump and re-pressurized when a lower pressure limit is reached. Once the target pressure has been achieved, the pump is disconnected from the containers.
- There is a discrepancy in the GTR requirement and procedure. The requirement states that the container is held at $\geq 85^{\circ}\text{C}$ whereas the procedure states that the temperature of the chamber and fluid is held within $\pm 5^{\circ}\text{C}$ of the target temperature.

4.8 Extreme Temperature Pressure Cycling Test

4.8.1 Test Specification

The testing was performed in accordance with UN GTR ECE/TRANS/180/Add.13, Section 5.1.2.6: Extreme temperature pressure cycling test. The test procedure is outlined in Section 6.2.2.2.

4.8.2 Test Procedure

The duration of the extreme temperature pressure cycling test was 10 days including setup and transfer between cold and hot chambers. The detailed test procedure was as follows.

- 1) The container was filled with a cold thermal fluid, ensuring that no air was entrapped.
- 2) The o-ring was lubricated with o-ring lubricant and installed on the container end plug. The end plug threads were coated with an anti-galling paste and installed into the container using the manufacturer-specified installation torque.
- 3) The end plug tubing ports were capped to prevent the fluid from draining during transportation and test setup.

TEST REPORT

No. TR-00663-01-R2

December 7, 2017

- 4) The container was placed inside a thermally controlled cycling chamber and conditioned to -40°C while a pressure of 1-2 MPa was maintained inside the container.
- 5) The container was pressure cycled from less than 2.0 MPa to 0.8 x NWP at a fluid and chamber temperature of less than -40°C for 1,500 cycles.
- 6) The container was then stabilized at zero pressure and ambient temperature.
- 7) The cold thermal fluid was drained from the container and replaced with water for the hot pressure cycling test.
- 8) The container was placed inside a different thermally controlled cycling chamber and conditioned to 85°C and 95% relative humidity.
- 9) The container was then pressure cycled from less than 2.0 MPa to 1.25 x NWP at a fluid and chamber temperature of greater than 85°C for 1,500 cycles.
- 10) The container was removed from the cycling chamber and drained.

4.8.3 Instrumentation and Setup

The sensors and equipment used for the extreme temperature pressure cycling test are shown in Table 19. The pressure transducer is located near the hydraulic pump approximately 8m from the test sample. The fluid temperature was measured by an in-line thermocouple approximately 5 cm away from the container inlet. The container skin temperature was measured on the outer hoop surface in the center of the container length. The skin temperature was only measured on the first container due to the similarities of the system as a whole. The chamber temperature was measured in the air approximately 10cm above the containers. All sensors were monitored by a data acquisition system and recorded as maximum and minimum values for each cycle.

Relative humidity during the hot test is assumed to be 100% as the containers are partially submerged in water.

Schematics of the test setup are shown in Figure 15 and Figure 16.

Table 19. Extreme Temperature Pressure Cycling Test Instrumentation and Equipment

Instrument/Equipment	Specification	Purpose
Pressure Transducer	0 to 90 MPa (minimum range)	Monitor container pressure
Temperature Sensor	-50°C to $+100^{\circ}\text{C}$ (minimum range)	Measure fluid, skin and chamber temperatures
Data Acquisition System	Minimum sampling frequency recommended 10 Hz.	Record container pressure, fluid, skin and chamber temperatures
Thermal Chamber (cold)	-50°C to ambient (minimum range)	Provide containment and cooling
Thermal Chamber (hot)	0 to $+90^{\circ}\text{C}$ (minimum range)	Provide containment and heating
Hydraulic Pump	Minimum output pressure of 90 MPa	Pressurize container

TEST REPORT

No. TR-00663-01-R2

December 7, 2017

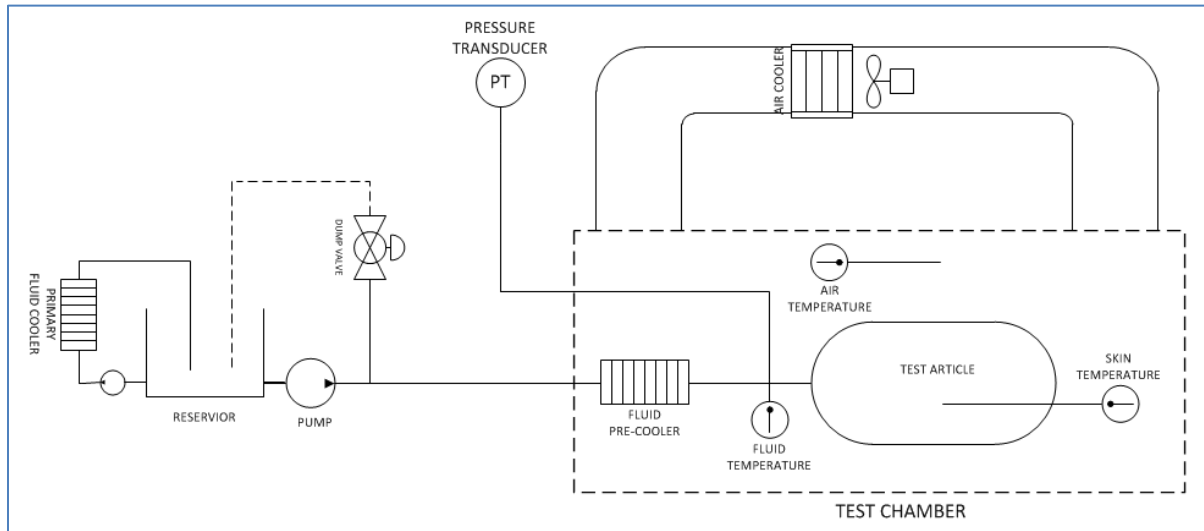

Figure 15. Cold Pressure Cycling Test Setup

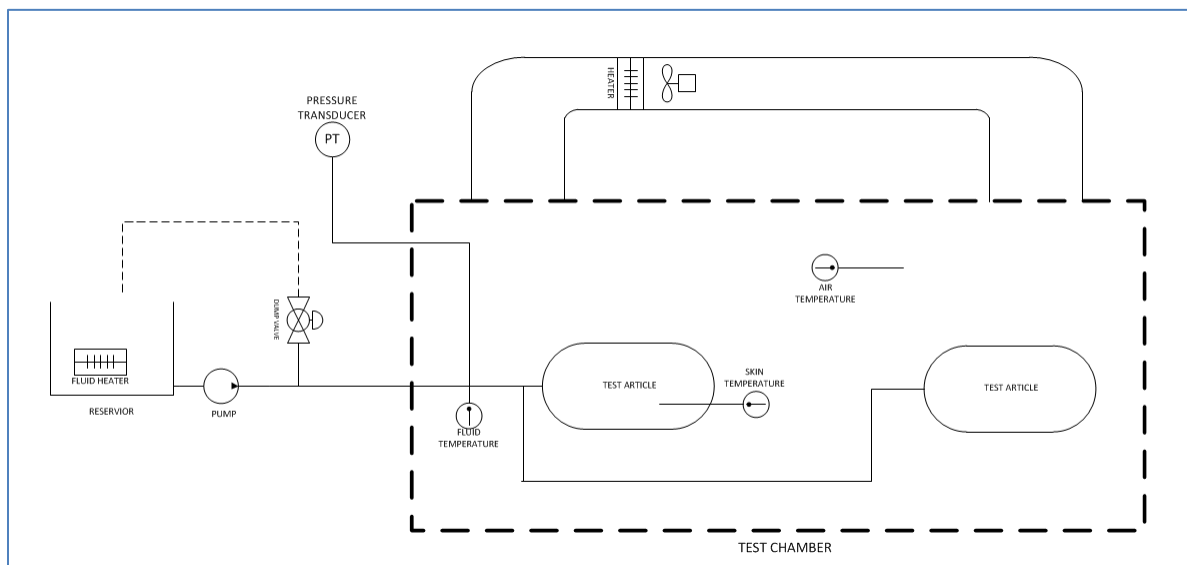

Figure 16. Hot Pressure Cycling Test Setup

4.8.4 Results

The extreme temperature pressure cycling test was performed on containers 1-E and 3-E only as container 2-E had already failed the sequence during the ambient cycle test. Figure 39 in Appendix A shows the fluid, skin and chamber temperature data during cold pressure cycling, which was performed without incident. The pressure data is shown in Figure 41 in Appendix A.

TEST REPORT

No. TR-00663-01-R2

December 7, 2017

During the hot pressure cycling test, after 910 pressure cycles, a leak was detected on the dome and sidewall of container 3-E.

The container was removed and the testing was continued with only container 1-E. Figure 40 in Appendix A shows the fluid, skin and chamber temperature data during hot pressure cycling. The pressure data is shown in Figure 42 in Appendix A.

The cycle rates throughout the test are shown in Table 20. The cycle rate for the hot test changed after 910 cycles due to the volume change after container 3-E was removed.

Table 20. Extreme Temperature Pressure Cycling Test Results

Sample number	Cold test cycle rate	Cold test cycles completed	Hot test cycle rate	Hot test cycles completed	Hot test cycle rate after 910 cycles	Comments
1-E	1.1 cycles/min	1500	0.86 cycles/min	1500	1.5 cycles/min	-
2-E	-	-	-	-	-	-
3-E	1.1 cycles/min	1500	0.86 cycles/min	910	-	Leak at dome and sidewall

4.8.5 Incident/Failure Report

Container 3-E did not pass the extreme temperature pressure cycling test. Details of the failure are shown in Table 21. An image of the leak is shown in Figure 17.

Table 21. Extreme Temperature Pressure Cycling Test Failure Report

Incident/Failure	Where failure occurred	When failure occurred	Evidence of failure	Description of failure
3-E	Hot Cycle Chamber. Leak on Sidewall	After 910 hot pressure cycles. November 26, 2015.	System could not build pressure fast enough	Container leak at dome and sidewall

TEST REPORT

No. TR-00663-01-R2

December 7, 2017



Figure 17. Leakage from dome and sidewall of container 3-E during hot pressure cycling

4.8.6 Observations

- The GTR extreme temperature test sequence starts with cold cycling then moves to hot cycling. This is contrary to most extreme temperature test protocols (i.e. HGV2 and EU406/EC79).

4.9 Hydraulic Residual Pressure Test and Residual Strength Burst Test

4.9.1 Test Specification

The testing was performed in accordance with UN GTR ECE/TRANS/180/Add.13, Section 5.1.2.7: Hydraulic residual pressure test and Section 5.1.2.8: Residual strength burst test. The test procedures are outlined in Sections 6.2.3.1 and 6.2.2.1 respectively.

4.9.2 Test Procedure

Each burst test took up to 2 hours to perform with an additional hour of preparation time. Each container was also temperature conditioned for 24 hours before the burst test in order to stabilize it to the specified temperature. The detailed test procedure was as follows:

- 1) The container was filled with water, ensuring that no air was entrapped.

TEST REPORT

No. TR-00663-01-R2

December 7, 2017

- 2) The o-ring was lubricated with o-ring lubricant and installed on the container end plug. The end plug threads were coated with an anti-galling paste and installed into the container using the manufacturer-specified installation torque.
- 3) The end plug tubing ports were capped to prevent water from draining during transportation and test setup.
- 4) The container was placed in a temperature-controlled environment of 15-25°C for a minimum of 24 hours for temperature conditioning. The container was removed immediately prior to the burst test.
- 5) The container was placed in the burst testing containment.
- 6) The supply tubing from the high pressure pump was connected to the test container with continuous (low pressure) supply water flowing to prevent the introduction of air into the system.
- 7) The container temperature was confirmed by measuring the temperature of the container surface prior to the test.
- 8) The burst testing containment was lowered into the burst pit.
- 9) The container was pressurized to 1.8 x NWP with water using a smooth and continuous pressure ramp rate and held at pressure for 4 minutes.
- 10) The container was then pressurized to failure for the residual strength burst test. The rate of pressure increase was maintained at less than 0.35 MPa/s throughout the test.
- 11) The container was removed from the burst testing bunker and photographed.

4.9.3 Instrumentation and Setup

The sensors and equipment used for the hydraulic residual pressure test and residual strength burst test are shown in Table 22. The sampling rate used during data recording was 1 Hz.

The pressure transducer is located near the data acquisition system approximately 23m from the test sample. An emergency pressure dump valve is also located on the same line. The container temperature is measured with a handheld digital thermometer on the container surface just prior to the test. A schematic of the test setup is shown in Figure 18.

Table 22. Hydraulic Residual Pressure Test and Burst Test Instrumentation and Equipment

Instrument/Equipment	Specification	Purpose
Pressure Transducer	0 to 275 MPa (minimum range)	Monitor container pressure
Data Acquisition System	Minimum sampling frequency of 1 Hz recommended.	Record container pressure ramp rate and burst pressure
Digital Thermometer	0°C to 50°C	Measure temperature of container prior to burst
Hydraulic Pump	Minimum output pressure of 275 MPa	Pressurize container with water

TEST REPORT

No. TR-00663-01-R2

December 7, 2017

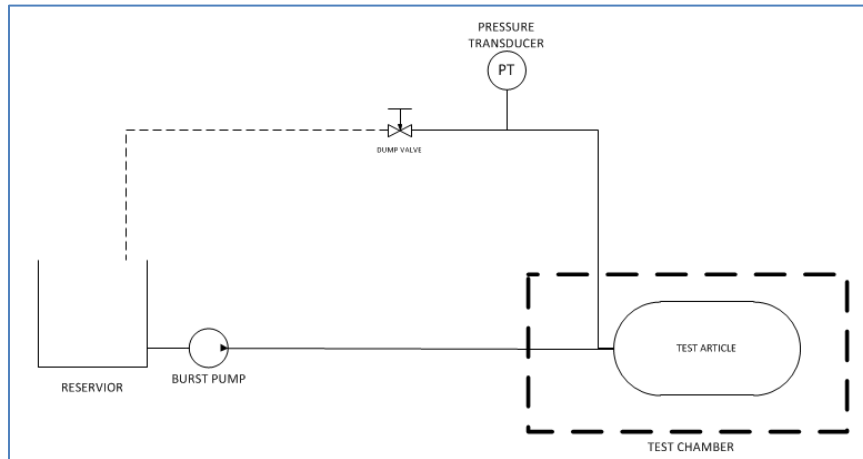

Figure 18. Hydraulic Residual Pressure Test and Burst Test Setup

4.9.4 Results

The hydraulic residual pressure test and residual strength burst test was performed on container 1-E only, as container 2-E had failed the ambient cycle test and container 3-E had failed the extreme temperature pressure cycling test.

The container burst pressure was found to be more than 80% of the BPo as determined in the baseline initial burst pressure test. The test results are shown in Table 23. The pressure profile data for the residual pressure and burst test is shown in Figure 43 in Appendix A.

Table 23. Hydraulic Residual Pressure Test and Burst Test Results

Sample number	Container temperature prior to burst	Burst pressure	BPo (avg burst pressure from baseline test)	Rupture mode
1-E	~20°C	165.3 MPa	189.0 MPa	Complete container rupture
2-E	-	-	-	-
3-E	-	-	-	-

4.9.5 Observations

- Since the burst test is almost always performed outdoors, a temperature range of 10°C to 40°C (similar to the NGV2 ambient temperature definition) would be more practical. The temperature range defined in the GTR is 15°C to 25°C. Loosening the temperature tolerance would also eliminate the need to temperature condition the container prior to the burst test. A 10°C to 40°C range would have no impact on the test and is supported by the OEMs.
- The hydraulic residual pressure test and the residual burst test procedure are performed in the same sequence and it would make sense to combine the procedures.

TEST REPORT

No. TR-00663-01-R2

December 7, 2017

4.10 Result Summary of Verification Test for Performance Durability (Hydraulic)

One container completed the entire hydraulic sequence. A summary of the test results for all 3 containers is shown in Table 24.

Table 24. Hydraulic Sequential Test Results

Sample number	Last test successfully completed	Comments
1-E	All	Completed all test sequences.
2-E	Chemical application	Container leaked during the ambient pressure cycling test after completing 294 cycles out of a required 4500 cycles.
3-E	Cold pressure cycling test	Container leaked during the hot pressure cycling test after completing 910 cycles out of a required 1500 cycles.

5 VERIFICATION TEST FOR EXPECTED ON-ROAD PERFORMANCE (Pneumatic Sequential Tests)

In this part of the regulation, a hydrogen storage system is tested under worst case conditions of expected exposures during the vehicle life. Testing includes hydrogen gas cycling at extreme temperatures and a permeation test to simulate parking in garages. Following this, the container further undergoes a proof pressure test and a burst test to evaluate the burst pressure after lifetime service. Two containers were tested without on-tank valves, thus not qualifying them as a 'hydrogen storage system'. Each container was subjected to the entire test sequence in the specified order.

5.1 Test Specification

The testing was performed in accordance with UN GTR ECE/TRANS/180/Add.13, Section 5.1.3, which contains the following test sequence:

- Proof pressure test (para. 5.1.3.1 and 6.2.3.1)
- Ambient and extreme temperature gas pressure cycling test (para. 5.1.3.2 and 6.2.4.1)
- Extreme temperature static pressure leak/permeation test (para. 5.1.3.3 and 6.2.4.2)
- Residual proof pressure test (para. 5.1.3.4 and 6.2.3.1)
- Residual strength burst test (para. 5.1.3.5 and 6.2.2.1)

5.2 Test Samples

The pneumatic sequential test was performed on two containers, one type III and one type IV. The sample number and container details are shown in Table 25.

Table 25. Test Samples used for the Pneumatic Sequential Tests

Sample number	Manufacturer number	Type	NWP (MPa)	Vol (L)	Condition
1-F	1	IV	70	30-40	Proof tested
3-F	3	III	70	20-30	Proof tested

5.3 Observations

- Section 5.1.3 states that a ‘hydrogen storage system’ is to undergo the entire pneumatic sequence. In addition to the container, this includes a TPRD, check valve, and shut-off valve, which are contained within the on-tank valve. These components are typically OEM specific and were not included as part of this test program. Despite this statement, sections 5.1.3.4 and 5.1.3.5 (proof pressure and burst test) require that only the ‘storage container’ is tested.
- The graph shown in Figure 19 is copied into the GTR document from SAE J2579. It is stated on the graph that a fuel delivery temperature of $<-35^{\circ}\text{C}$ is required, which is contrary to the text of the regulation.

Verification test for expected on-road performance (pneumatic/hydraulic)

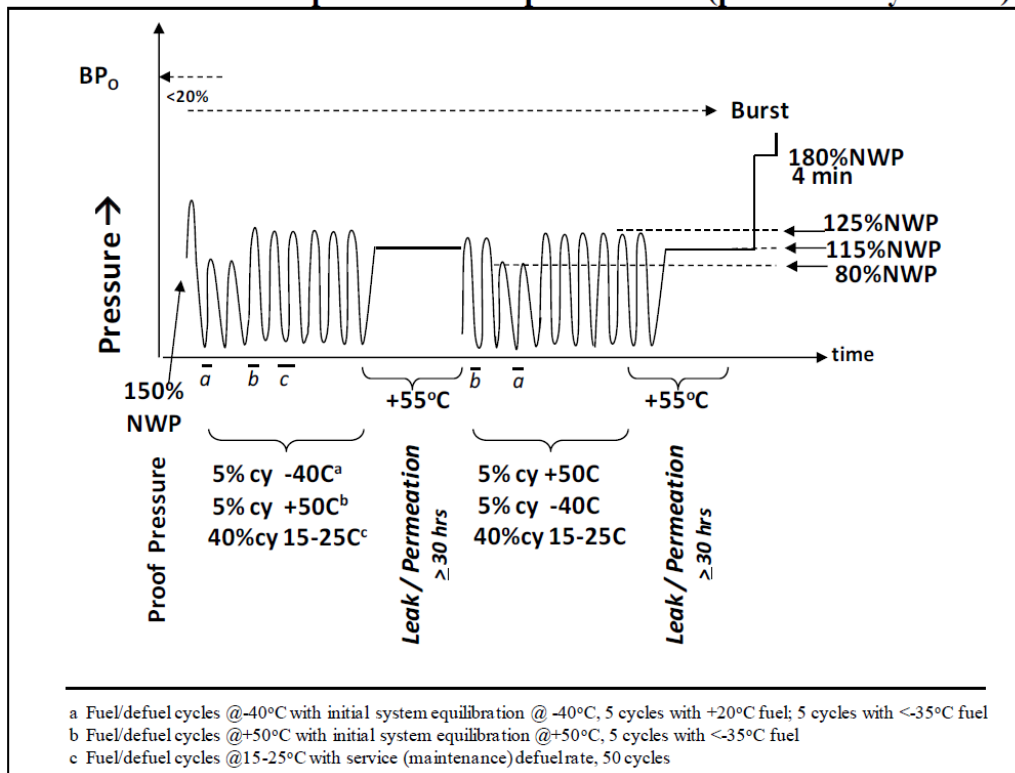

Figure 19. GTR pneumatic sequence diagram (copied from SAE J2579)

TEST REPORT

No. TR-00663-01-R2

December 7, 2017

5.4 Proof Pressure Test

5.4.1 Test Specification

The proof pressure test was performed by the container manufacturer. The test is as per UN GTR ECE/TRANS/180/Add.13, Section 5.1.3.1: Proof pressure test. The test procedure is outlined in Section 6.2.3.1.

5.4.2 Test Procedure

The proof pressure test was performed by the container manufacturer. An example test procedure is outlined here for reference. The proof pressure test typically takes 2 hours with 24 hours of prep time. The containers are tested separately. The detailed test procedure is as follows.

- 7) The container is filled with water ensuring no air is entrapped.
- 8) The end plug o-ring is lubricated with o-ring lubricant and installed on the container end plug. The end plug threads are coated with an anti-galling paste and installed into the container using the manufacturer-specified installation torque.
- 9) The end plug tubing ports are capped to prevent water from draining during transportation and test setup.
- 10) The container is installed into the burst testing facility and connected to the pressurization equipment.
- 11) The container is pressurized to greater than 1.5 x NWP (105 MPa) for 30 seconds.
- 12) After test completion, the container is removed from the chamber and drained of water.

5.4.3 Instrumentation and Setup

The sensors and equipment typically used for the proof pressure test are shown in Table 26 for reference. The pressure transducer readout is recorded by a data acquisition system at a sampling rate of 1Hz minimum. A schematic of the test setup is shown in Figure 20.

Table 26. Proof Pressure Test Instrumentation and Equipment

Instrument/Equipment	Specification	Purpose
Pressure Transducer	0 to 110 MPa (minimum range)	Monitor container pressure
Hydraulic Pump	Minimum output pressure capability of 110 MPa	Pressurize container with water

TEST REPORT

No. TR-00663-01-R2

December 7, 2017

Powertech

Powertech Labs Inc.
12388 88th Ave.
Surrey, BC V3W 7R7 Canada

tel: +1 (604) 590-7500
fax: +1 (604) 590-6659
www.powertechlabs.com

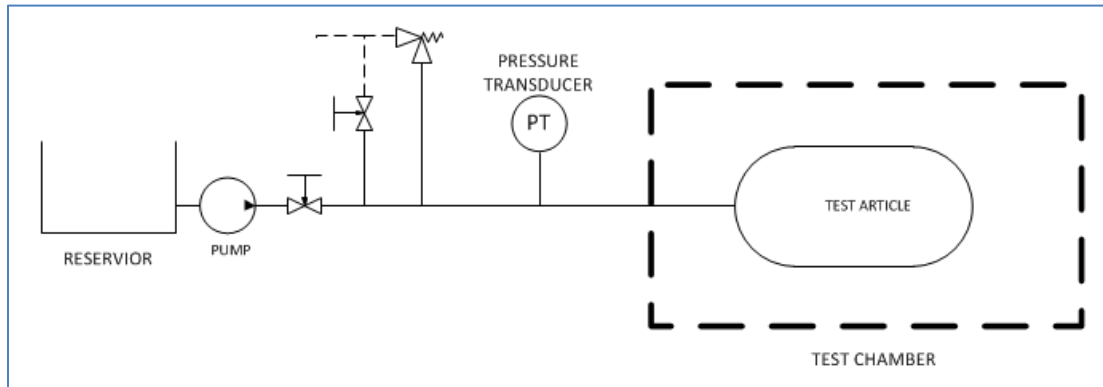

Figure 20. Proof Pressure Test Setup

5.4.4 Results

The proof test was completed by the manufacturer prior to delivery of the container to Powertech.

5.4.5 Observations

- The proof pressure test is typically performed by the manufacturer as part of the general manufacturing process. It is expected that the manufacturer will notify the test lab if the proof test was not performed. A record of the test is not typically required but can be requested from the manufacturer if necessary.

5.5 Ambient and Extreme Temperature Gas Pressure Cycling Test

5.5.1 Test Specification

The testing was performed in accordance with UN GTR ECE/TRANS/180/Add.13, Section 5.1.3.2: Ambient and extreme temperature gas pressure cycling test. The test procedure is outlined in Section 6.2.4.1.

5.5.2 Test Procedure

The gas pressure cycling test took 3 months to complete. The detailed test procedure was as follows.

- 1) The containers were purged with nitrogen and then with hydrogen.
- 2) The containers were installed into the gas cycle environmental chamber.

3) The containers were subjected to 500 gas cycles as per the following test stages. A summary can be found in Table 27.

- Stage 1: Ambient temperature of $\leq -40^{\circ}\text{C}$
Equilibrate to $\geq 0.8 \times \text{NWP}$ and $\leq -40^{\circ}\text{C}$
Defuel from $\geq 0.8 \times \text{NWP}$ to $\leq 2 \text{ MPa}$
Fill to $\geq 1.0 \times \text{NWP}$ with $15\text{-}25^{\circ}\text{C}$ fuel
For 5 cycles
- Stage 2: Ambient temperature of $\leq -40^{\circ}\text{C}$
Equilibrate to $\geq 0.8 \times \text{NWP}$ and $\leq -40^{\circ}\text{C}$
Defuel from $\geq 0.8 \times \text{NWP}$ to $\leq 2 \text{ MPa}$
Fill to $\geq 1.0 \times \text{NWP}$ with -40°C to -33°C fuel
For 5 cycles
- Stage 3: Ambient temperature of $\leq -40^{\circ}\text{C}$
Fill to $\geq 1.0 \times \text{NWP}$ with -40°C to -33°C fuel
Defuel to $\leq 2 \text{ MPa}$ at an ambient temperature
For 15 cycles
- Stage 4: Ambient temperature of $\geq 50^{\circ}\text{C}$ and relative humidity of 95-100%
Equilibrate to $\leq 2 \text{ MPa}$ and $\geq 50^{\circ}\text{C}$
Fill to $\geq 1.25 \times \text{NWP}$ with -40°C to -33°C fuel
Defuel to $\leq 2 \text{ MPa}$
For 5 cycles
- Stage 5: Ambient temperature of $\geq 50^{\circ}\text{C}$ and relative humidity of 95-100%
Fill to $\geq 1.25 \times \text{NWP}$ with -40°C to -33°C fuel
Defuel to $\leq 2 \text{ MPa}$
For 20 cycles
- Stage 6: Ambient temperature of $15\text{-}25^{\circ}\text{C}$
Fill to $\geq 1.25 \times \text{NWP}$ with -40°C to -33°C fuel
Defuel to $\leq 2 \text{ MPa}$
For 200 cycles
- Stage 7: Containers undergo a permeation test as described in section 4.4
- Stage 8: Ambient temperature of $\geq 50^{\circ}\text{C}$ and relative humidity of 95-100%
Fill to $\geq 1.25 \times \text{NWP}$ with -40°C to -33°C fuel
Defuel to $\leq 2 \text{ MPa}$
For 25 cycles
- Stage 9: Ambient temperature of $\leq -40^{\circ}\text{C}$
Fill to $\geq 1.0 \times \text{NWP}$ with -40°C to -33°C fuel
Defuel to $\leq 2 \text{ MPa}$
For 25 cycles
- Stage 10: Ambient temperature of $15\text{-}25^{\circ}\text{C}$
Fill to $\geq 1.25 \times \text{NWP}$ with -40°C to -33°C fuel
Defuel to $\leq 2 \text{ MPa}$
For 200 cycles
- Stage 11: Containers undergo a permeation test as described in section 4.4

TEST REPORT

No. TR-00663-01-R2

December 7, 2017

- Stages 12 and 13: Containers undergo a pressure proof and burst test as described in sections 4.5 and 4.6
- 4) The fill time was approximately 3 minutes except during hot cycles and cycles where a fuel delivery temperature of +20°C was required. The mass flow rate did not exceed 60 g/s. The pressure ramp rate for fueling and defueling was recorded for each cycle.
- 5) The fuel delivery temperature at the point where the fuel enters the storage system was $-40^{\circ}\text{C} \leq T_{\text{fuel}} \leq -33^{\circ}\text{C}$.
- 6) The defueling time was approximately 1 hour except where the defuel was limited by the minimum container temperature (cold cycles).
- 7) The maintenance/maximum defueling time used for 50 ambient cycles was approximately 1 hour as specified by the container manufacturer.
- 8) The upper internal container gas temperature limit was 85°C.
- 9) The lower internal container gas temperature limit was -60°C as specified by the container manufacturer.

Table 27: Expected On-Road Performance Test Stages

Stage	Description	Cycles	Min pressure	Max pressure	Ambient temperature	Soak	Gas delivery temperature
1	Cold cycles	5	$\leq 2 \text{ MPa}$	$\geq 1.0 \times \text{NWP}$	$\leq -40^{\circ}\text{C}$	yes	15-25°C
2	Cold cycles	5	$\leq 2 \text{ MPa}$	$\geq 1.0 \times \text{NWP}$	$\leq -40^{\circ}\text{C}$	yes	-40°C to -33°C
3	Cold cycles	15	$\leq 2 \text{ MPa}$	$\geq 1.0 \times \text{NWP}$	$\leq -40^{\circ}\text{C}$	no	-40°C to -33°C
4	Hot cycles	5	$\leq 2 \text{ MPa}$	$\geq 1.25 \times \text{NWP}$	$\geq 50^{\circ}\text{C}$, 95-100% RH	yes	-40°C to -33°C
5	Hot cycles	20	$\leq 2 \text{ MPa}$	$\geq 1.25 \times \text{NWP}$	$\geq 50^{\circ}\text{C}$, 95-100% RH	no	-40°C to -33°C
6	Ambient cycles	200	$\leq 2 \text{ MPa}$	$\geq 1.25 \times \text{NWP}$	15-25°C	no	-40°C to -33°C
7	Permeation test	-	-	$\geq 1.15 \times \text{NWP}$	$\geq 55^{\circ}\text{C}$	-	-
8	Hot cycles	25	$\leq 2 \text{ MPa}$	$\geq 1.25 \times \text{NWP}$	$\geq 50^{\circ}\text{C}$, 95-100% RH	no	-40°C to -33°C
9	Cold cycles	25	$\leq 2 \text{ MPa}$	$\geq 1.0 \times \text{NWP}$	$\leq -40^{\circ}\text{C}$	no	-40°C to -33°C
10	Ambient cycles	200	$\leq 2 \text{ MPa}$	$\geq 1.25 \times \text{NWP}$	15-25°C	no	-40°C to -33°C
11	Permeation test	-	-	$\geq 1.15 \times \text{NWP}$	$\geq 55^{\circ}\text{C}$	-	-
12	Proof pressure test (1.8 x NWP)						
13	Residual strength burst test						

5.5.3 Instrumentation and Setup

The instrumentation and equipment used for the gas pressure cycling test are shown in Table 28. The sensors are recorded by a data acquisition system at a sampling rate of 1Hz.

The pressure transducer monitoring the test pressure is located as close to the test sample as possible but outside of the chamber to prevent the sensor from being exposed to extreme

TEST REPORT

No. TR-00663-01-R2

December 7, 2017

temperatures. The fuel delivery temperature is measured at the point where the gas exits the pre-cooler. A schematic of the test setup is shown in Figure 21.

Table 28. Ambient and Extreme Temperature Gas Pressure Cycling Test Instrumentation and Equipment

Name	Instrument/Equipment	Range	Purpose
Ptest	Pressure Transducer	20,000 psi	Monitor container pressure
S_Tank, L_Tank	Temperature Sensor	-100°C to 150°C	Measure in-tank temperatures
S_Skin, L_Skin	Temperature Sensor	-100°C to 150°C	Measure tank surface temperatures
Tfuel	Temperature Sensor	-100°C to 150°C	Measure fuel delivery temperature
Tamb	Temperature Sensor	-100°C to 150°C	Measure chamber temperature
RH	Relative Humidity Sensor	0 to 100% RH	Measure chamber relative humidity

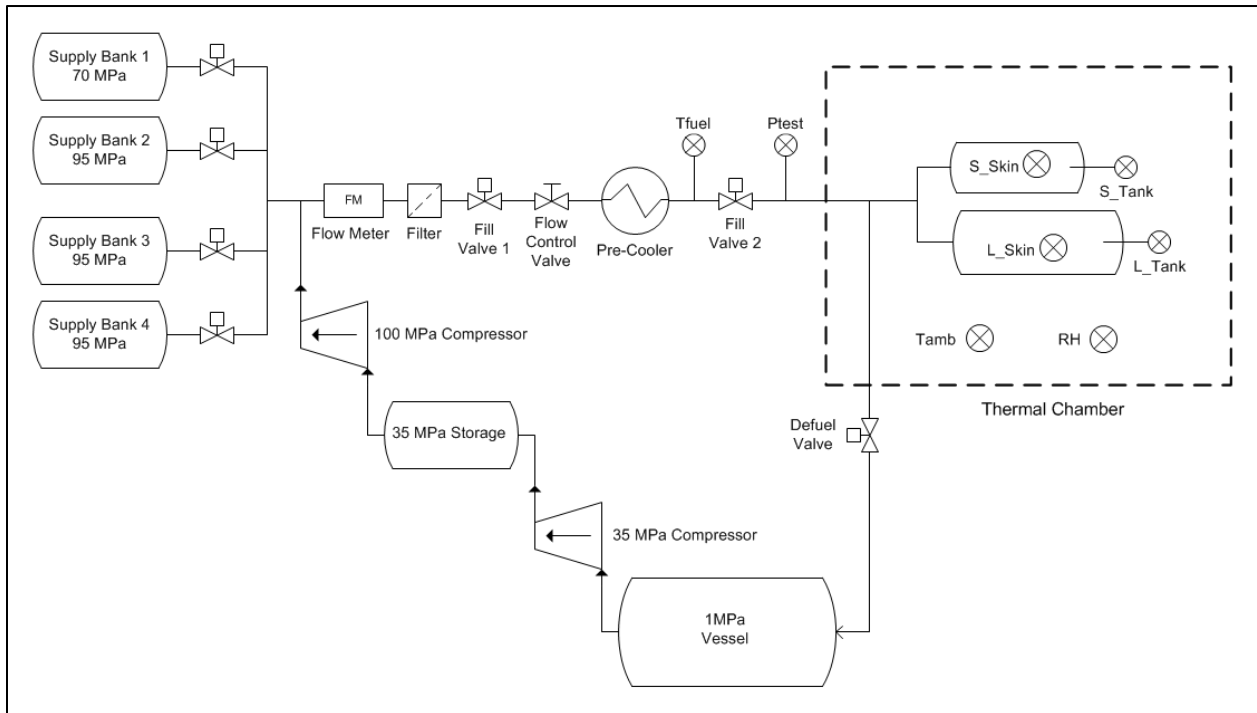

Figure 21. Ambient and Extreme Temperature Gas Pressure Cycling Test Setup

5.5.4 Results

Both containers completed 500 hydrogen pressure cycles without any sign of leakage. A data plot of each test stage can be found in Figure 44 to Figure 61 in Appendix A. The approximate fueling and defueling rates during each test stage are shown in

Table 29. Note, that the maintenance defueling rate was the same as the defueling rate used for all other ambient cycles.

TEST REPORT

No. TR-00663-01-R2

December 7, 2017

Table 29. Ambient and Extreme Temperature Gas Pressure Cycling Test Results

Stage	Ambient Temperature (°C)	Fueling Time (minutes)	Defueling Time (hours)	Soak Time (hours)	Total Cycle Time (hours)
1	-40	6.3	5.4	8.5	14
2	-40	3.2	4.5	3.9	8.5
3	-40	3.1	2.5	-	2.6
4	50	7.2	0.9	12.5	13.5
5	50	6.1	0.9	-	1.0
6	20	3.1	1.0	-	1.0
8	50	6.0	1.3	-	1.4
9	-40	2.9	4.2	-	4.2
10	20	3.0	1.2	-	1.2

5.5.5 Observations

- The regulation specifies a gas fuel temperature of $\leq -40^{\circ}\text{C}$, which contradicts $< -35^{\circ}\text{C}$ in Figure 3 on the same page. The figure is copied from SAE J2579, which specifies a gas fuel temperature of $\leq -35^{\circ}\text{C}$. The regulation also refers to SAE J2601 in the rationale section. It states “fuel temperature for 70 MPa fast fueling is $\sim -40^{\circ}\text{C}$ ”. SAE J2601 specifies a fuel delivery temperature range of $-40^{\circ}\text{C} \leq T_{\text{fuel}} \leq -33^{\circ}\text{C}$. For this particular test program, the fuel delivery temperature followed the T40 category requirements as defined in SAE J2601, except when otherwise specified.
- The regulation requires a target pressure of 56 MPa for cold cycles. This has been increased to NWP (70 MPa) in SAE J2579. Fueling at cold ambient temperatures in real world scenarios will result in container pressures > 56 MPa due to the internal gas temperatures increasing during fueling. For this reason, the target pressures for -40°C fueling in SAE J2601 are higher than 70 MPa.
- Fill time is specified as “a constant 3 minute pressure ramp rate” in section 6.2.4.1. This is not possible for some of the cycles. When a fuel delivery temperature of $+20^{\circ}\text{C}$ is required (stage 1), the containers will exceed the upper temperature limit of 85°C at this ramp rate. The same goes for the hot cycles (stages 4, 5 and 8).
- Equilibration steps are out of order if trying to achieve worst case scenarios. This has been corrected in SAE J2579.
- There is no lower container temperature limit specified in the regulation. Lower gas limit is therefore dictated by the manufacturer. During the -40°C cycles with temperature conditioning, the defuel begins with the container conditioned to -40°C . The container temperature will drop further as the container depressurizes, so the minimum allowable temperature must be lower than the typical -40°C .

December 7, 2017

5.6 Extreme Temperature Static Pressure Leak/Permeation Test

5.6.1 Test Specification

The testing was performed in accordance with UN GTR ECE/TRANS/180/Add.13, Section 5.1.3.3: Extreme temperature static pressure leak/permeation test. The test procedure is outlined in Section 6.2.4.2.

5.6.2 Test Procedure

The containers were subjected to 2 permeation tests as per Table 27. The containers were tested in separate chambers with on-tank valves installed. The duration of each permeation test was 1 week. The detailed test procedure was as follows.

- 1) The containers were filled with hydrogen gas to 100% SOC (1.0 x NWP at 15°C).
- 2) The containers were placed in air-sealed permeation chambers located inside a thermal chamber controlled to $\geq 55^{\circ}\text{C}$.
- 3) The containers were stabilized to 80.5 MPa and 55°C for at least 30 hours.
- 4) The permeation chambers were purged with nitrogen to start the test.
- 5) Chamber gas samples were taken regularly and analyzed with a gas chromatograph.
- 6) The test was stopped after the permeation rate reached steady state.
- 7) After the permeation test, the containers underwent a localized leak check using a liquid leak detector.

5.6.3 Instrumentation and Setup

The sensors and equipment used for the permeation test are shown in Table 30. The hydrogen concentration and temperature were measured at least five times per week. The pressure transducer was only connected to the container prior to installing it in the permeation chamber to confirm the pressure. A schematic of the test setup is shown in Figure 22.

Table 30. Permeation Test Instrumentation and Equipment

Instrument/Equipment	Specification	Purpose
Pressure Transducer	0 to 90 MPa (minimum range)	Check container pressure prior to test
Temperature Sensor	+60°C (minimum range)	Measure chamber temperature
Permeation Chamber	Sealed chamber with sampling port	Provide sealed chamber to capture hydrogen leakage from container
Gas Analyzer	Gas chromatograph or mass spectrometer	Measure precise ppm level of hydrogen in permeation chamber

TEST REPORT

No. TR-00663-01-R2

December 7, 2017

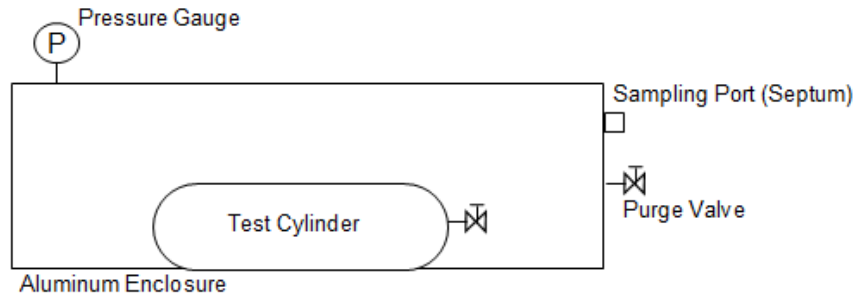

Figure 22. Permeation Test Setup

5.6.4 Results

Both containers were subjected to the permeation test and had permeation rates below the maximum limit of 46 mL/h/L. The test results are shown in Table 31. A graph of each permeation test can be found in Figure 62 to Figure 65 in Appendix A.

Table 31. Permeation Test Results

Sample number	Temperature Test #1	Permeation Rate Test #1	Temperature Test #2	Permeation Rate Test #2
1-F	55-57°C	5.86 ml/hr/L	55-57°C	14.38 ml/hr/L
3-F	55-57°C	0.014 ml/hr/L	55-57°C	0.008 ml/hr/L

5.6.5 Observations

- Steady-state is not defined in the GTR document. SAE J2579 defines steady-state as “at least 3 consecutive readings separated by at least 12 hours being within $\pm 10\%$ of reading”.

5.7 Residual Proof Pressure Test and Residual Strength Burst Test (Hydraulic)

5.7.1 Test Specification

The testing was performed in accordance with UN GTR ECE/TRANS/180/Add.13, Section 5.1.3.4: Residual proof pressure test and Section 5.1.3.5: Residual strength burst test. The test procedures are outlined in Sections 6.2.3.1 and 6.2.2.1 respectively.

TEST REPORT

No. TR-00663-01-R2

December 7, 2017

5.7.2 Test Procedure

Each burst test took up to 2 hours to perform with an additional hour of preparation time. Each container was also temperature conditioned for 24 hours before the burst test in order to stabilize it to the specified temperature. The detailed test procedure was performed as follows:

- 1) The container was filled with water, ensuring that no air was entrapped.
- 2) The o-ring was lubricated with o-ring lubricant and installed on the container end plug. The end plug threads were coated with an anti-galling paste and installed into the container using the manufacturer-specified installation torque.
- 3) The end plug tubing ports were capped to prevent water from draining during transportation and test setup.
- 4) The container was placed in a temperature-controlled environment of 15-25°C for a minimum of 24 hours for temperature conditioning. The container was removed immediately prior to the burst test.
- 5) The container was placed in the burst testing containment.
- 6) The supply tubing from the high pressure pump was connected to the test container with continuous (low pressure) supply water flowing to prevent the introduction of air into the system.
- 7) The container temperature was confirmed by measuring the temperature of the container surface prior to the test.
- 8) The burst testing containment was lowered into the burst pit.
- 9) The container was pressurized to 1.8 x NWP with water using a smooth and continuous pressure ramp rate and held at pressure for 4 minutes.
- 10) The container was then pressurized to failure with water for the residual strength burst test. The rate of pressure increase was maintained at less than 0.35 MPa/s throughout the test.
- 11) The container was removed from the burst testing bunker and photographed.

5.7.3 Instrumentation and Setup

The sensors and equipment used for the burst test are shown in Table 32. The sampling rate used during data recording was 1 Hz. The pressure transducer is located near the data acquisition system approximately 23m from the test sample. An emergency pressure dump valve is also located on the same line. The container temperature is measured with a handheld digital thermometer on the container surface just prior to the test. A schematic of the test setup is shown in Figure 23.

TEST REPORT

No. TR-00663-01-R2

December 7, 2017

Table 32. Residual Strength Burst Test Instrumentation and Equipment

Instrument/Equipment	Specification	Purpose
Pressure Transducer	0 to 275 MPa (minimum range)	Monitor container pressure
Data Acquisition System	Minimum sampling frequency of 1 Hz recommended.	Record container pressure ramp rate and burst pressure
Digital Thermometer	0°C to 50°C	Measure temperature of container prior to burst
Hydraulic Pump	Minimum output pressure of 275 MPa	Pressurize container with water

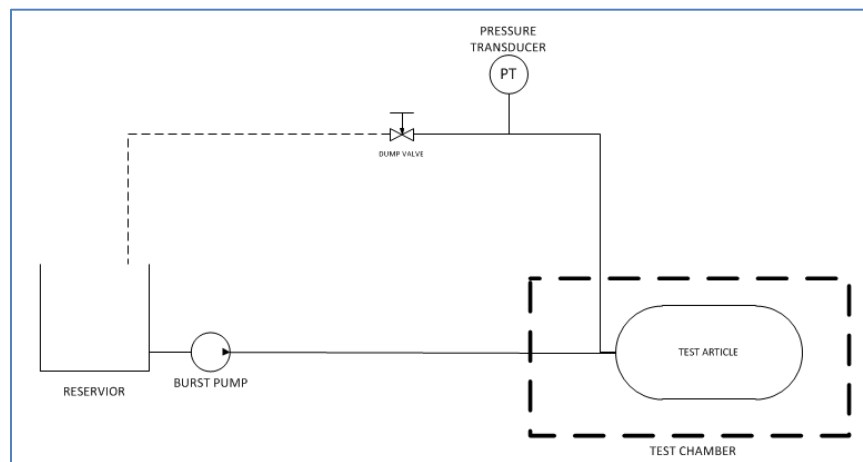

Figure 23. Residual Strength Burst Test Setup

5.7.4 Results

Both containers were subjected to the burst test. The burst pressure for both containers was within 20% of the BPo as determined in the baseline initial burst pressure test. The test results are shown in Table 33. Data plots of the pressure profiles can be found in Figure 66 and Figure 67 in Appendix A.

Table 33. Pneumatic Sequence Residual Strength Burst Test Results

Sample number	Container temperature prior to burst	Burst pressure	BPo (avg burst pressure from baseline test)	Rupture mode
1-F	22.3°C	193.5 MPa	189.0 MPa	Complete container rupture
1-F	19.6°C	235.7 MPa	252.2 MPa	End fitting detached, container intact

TEST REPORT

No. TR-00663-01-R2

December 7, 2017

Powertech

Powertech Labs Inc.
12388 88th Ave.
Surrey, BC V3W 7R7 Canada

tel: +1 (604) 590-7500

fax: +1 (604) 590-6659

www.powertechlabs.com

5.7.5 Observations

- Since the burst test is almost always performed outdoors, a temperature range of 10°C to 40°C (similar to the NGV2 ambient temperature definition) would be more practical. The temperature range defined in the GTR is 15°C to 25°C. Loosening the temperature tolerance would also eliminate the need to temperature condition the container prior to the burst test. A 10°C to 40°C range would have no impact on the test and is supported by the OEMs.
- The hydraulic residual pressure test and the residual burst test procedure are performed in the same sequence and it would make sense to combine the procedures.

6 VERIFICATION TEST FOR SERVICE TERMINATING PERFORMANCE IN FIRE

This test was not performed as part of this test program. The test procedure and setup and instrumentation requirements are based on Powertech's experience performing this test and are included here for reference.

6.1.1 Test Specification

The testing is performed in accordance with UN GTR ECE/TRANS/180/Add.13, Section 5.1.4: Verification test for service terminating performance in fire. The test procedure is outlined in Section 6.2.5.1.

6.1.2 Test Samples

The localized fire test is typically performed on one container.

6.1.3 Test Procedure

This test was not performed as part of this test program. The procedure below highlights the test protocol that Powertech follows when performing the localized fire test. The container is tested with an on-tank valve including a TPRD. The test is performed at Powertech's remote testing facility and typically takes 1-2 weeks including preparation time.

- 1) The container on-tank valve and end plug are visually inspected prior to testing to ensure the gas pathway is unobstructed for remote venting.
- 2) The container is purged with nitrogen.
- 3) The container is filled with hydrogen to NWP (70 MPa).
- 4) The container is installed on the localized fire assembly such that the bottom of the container is 100 mm above the fire source.

TEST REPORT

No. TR-00663-01-R2

December 7, 2017

- 5) The localized burner is positioned at the container end opposite the TPRD, or centered if two TPRDs are installed.
- 6) The TPRD port is connected to a remote vent stack.
- 7) The localized fire is generated with LPG and ignited remotely.
- 8) After 10 minutes, the remaining burners are activated to start the engulfing fire.
- 9) The fire stays active until the TPRD activates and the container vents to < 1MPa or a rupture occurs.
- 10) The temperature profile for both the localized and engulfing fires is shown in Figure 24.
- 11) The test is aborted if there is no TPRD activation or rupture after 30 minutes of continuous engulfing fire.

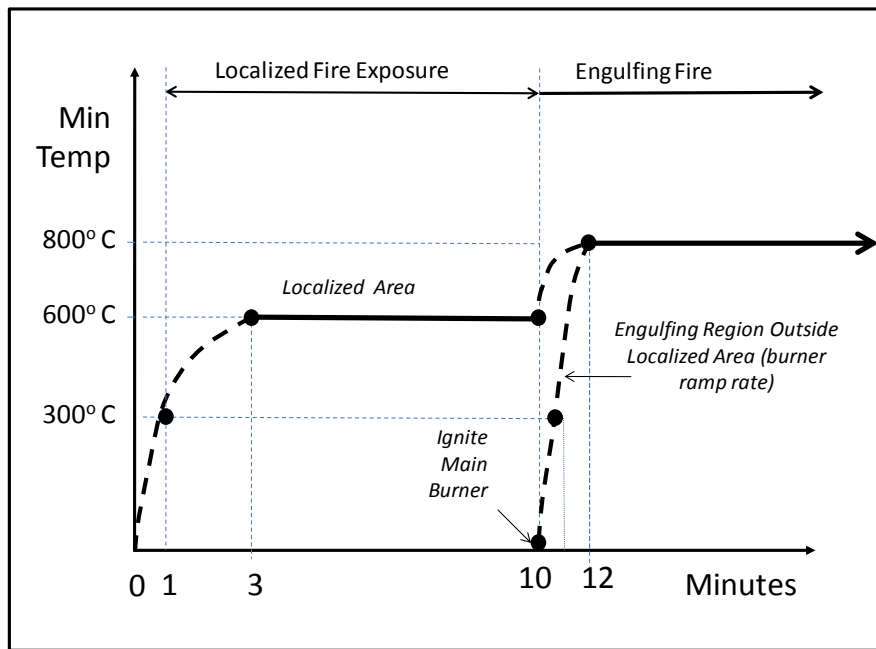

Figure 24. Localized Fire Test Temperature Profile

6.1.4 Instrumentation and Setup

The sensors and equipment used for the localized fire test are shown in Table 34. The test is documented with two video cameras to capture the TPRD release or rupture from multiple angles. The container pressure and temperature are recorded by a data acquisition system at a sampling rate of 1Hz minimum.

A schematic of the test setup including the relative positions of the thermocouples is shown in Figure 25.

Table 34. Localized Fire Test Instrumentation and Equipment

Instrument/Equipment	Specification	Purpose
Pressure Transducer	0 to 275 MPa	Monitor container pressure
Temperature Sensor	0°C to 1200°C	Measure flame temperatures

TEST REPORT

No. TR-00663-01-R2

December 7, 2017

Data Acquisition System	Minimum sampling frequency of 1 Hz recommended.	Record data
Fire Test Equipment	Produce controllable flame temperatures	Produce localized and engulfing flame

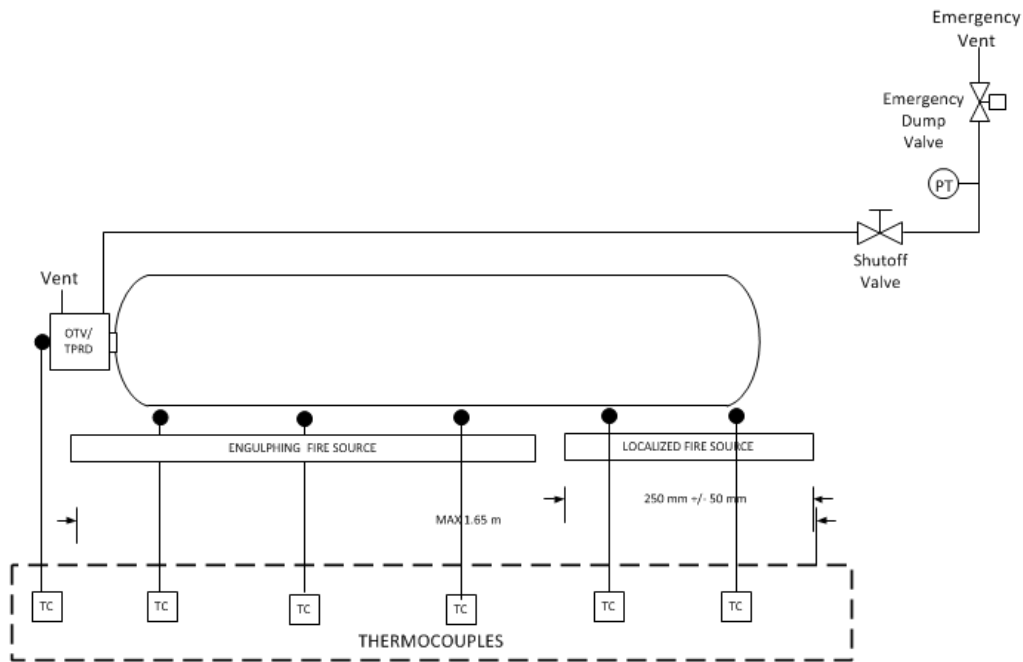

(Not to scale but accurate in showing relative position)

Figure 25. Localized Fire Test Schematic

6.1.5 Observations

- The localized fire test carries a higher risk than a standard bonfire test per NGV2 or EU406/EC79 and is conducted with more safeguards and in extremely remote locations.

TEST REPORT

No. TR-00663-01-R2

December 7, 2017

Powertech

Powertech Labs Inc.
12388 88th Ave.
Surrey, BC V3W 7R7 Canada

tel: +1 (604) 590-7500
fax: +1 (604) 590-6659
www.powertechlabs.com

7 VERIFICATION TEST FOR PERFORMANCE DURABILITY OF PRIMARY CLOSURES

This test was not performed as part of this test program. Observations made while performing this testing at Powertech in the past are included here for reference.

7.1 TPRD Qualification Requirements

7.1.1 Test Specification

As per UN GTR ECE/TRANS/180/Add.13, Section 5.1.5.1: TPRD qualification requirements. The test procedures are outlined in the following sections:

- Pressure cycling test (para. 6.2.6.1.1)
- Accelerated life test (para. 6.2.6.1.2)
- Temperature cycling test (para. 6.2.6.1.3)
- Salt corrosion resistance test (para. 6.2.6.1.4)
- Vehicle environment test (para. 6.2.6.1.5)
- Stress corrosion cracking test (para. 6.2.6.1.6)
- Drop and vibration test (para. 6.2.6.1.7)
- Leak test (para. 6.2.6.1.8)
- Bench top activation test (para. 6.2.6.1.9)
- Flow rate test (para. 6.2.6.1.10)

7.1.2 Observations

- Pressure cycling test
 - No observations
- Accelerated life test
 - No leakage rate given in this test.
- Temperature cycling test
 - No observations
- Salt corrosion resistance test
 - Reference pH 10 test. Carbon dioxide naturally dissolves into water producing carbonic acid. This then reacts with the sodium hydroxide reducing the pH. Sodium hydroxide does not establish a buffer in water so as more carbon dioxide dissolves, the lower the pH will become without adding more sodium hydroxide.

TEST REPORT

No. TR-00663-01-R2

December 7, 2017

Powertech

Powertech Labs Inc.
12388 88th Ave.
Surrey, BC V3W 7R7 Canada

tel: +1 (604) 590-7500

fax: +1 (604) 590-6659

www.powertechlabs.com

Over an 8 hour period with a larger open/covered tank (ie. 30 L) seeing get a drop of 0.5 pH or more has been observed.

- Vehicle environment test
 - Test requires that sodium hydroxide be used on the part. The majority of automotive parts are manufactured from aluminium. Sodium hydroxide reacts with aluminium and causes the part to dissolve.
- Stress corrosion cracking test
 - No observations
- Drop and vibration test
 - No observations
- Leak test
 - No observations
- Bench top activation test
 - No observations
- Flow rate test
 - No observations

7.2 Check Valve and Automatic Shut-off Valve Qualification Requirements

7.2.1 Test Specification

As per UN GTR ECE/TRANS/180/Add.13, Section 5.1.5.2: Check valve and automatic shut-off valve qualification requirements. The test procedures are outlined in the following sections:

- Hydrostatic strength test (para. 6.2.6.2.1)
- Leak test (para. 6.2.6.2.2)
- Extreme temperature pressure cycling test (para. 6.2.6.2.3)
- Salt corrosion resistance test (para. 6.2.6.2.4)
- Vehicle environment test (para. 6.2.6.2.5)
- Atmospheric exposure test (para. 6.2.6.2.6)
- Electrical tests (para. 6.2.6.2.7)
- Vibration test (para. 6.2.6.2.8)
- Stress corrosion cracking test (para. 6.2.6.2.9)
- Pre-cooled hydrogen exposure test (para. 6.2.6.2.10)

TEST REPORT

No. TR-00663-01-R2

December 7, 2017

7.2.2 Observations

- Hydrostatic strength test
 - No observations
- Leak test
 - This is an external leak test only. There is no provision for an internal leakage test of the check valve and the shut off valve.
- Extreme temperature pressure cycling test
 - The test specifies that inlet and outlet ports be pressurized and then the shut off valve be cycled on and off. There is no test for the functionality of the valve.
 - Leakage test is only required at ambient. There is no provision for leakage tests at maximum and minimum temperatures.
- Salt corrosion resistance test
 - Leakage test is only required at ambient. There is no provision for leakage tests at maximum and minimum temperatures.
- Vehicle environment test
 - Test requires that sodium hydroxide be used on the part. The majority of automotive parts are manufactured from aluminium. Sodium hydroxide reacts with aluminium and causes the part to dissolve.
 - Leakage test is only required at ambient. There is no provision for leakage tests at maximum and minimum temperatures.
- Atmospheric exposure test
 - There is no provision for hydrogen exposure for non-metallic materials.
- Electrical tests
 - Not all electrical systems are 12V or 24V.
- Vibration test
 - Leakage test is only required at ambient. There is no provision for leakage tests at maximum and minimum temperatures.
- Stress corrosion cracking test
 - No observations
- Pre-cooled hydrogen exposure test
 - Leakage test is only required at ambient. There is no provision for leakage tests at maximum and minimum temperatures.

TEST REPORT

No. TR-00663-01-R2

December 7, 2017

8 APPENDIX A – DATA

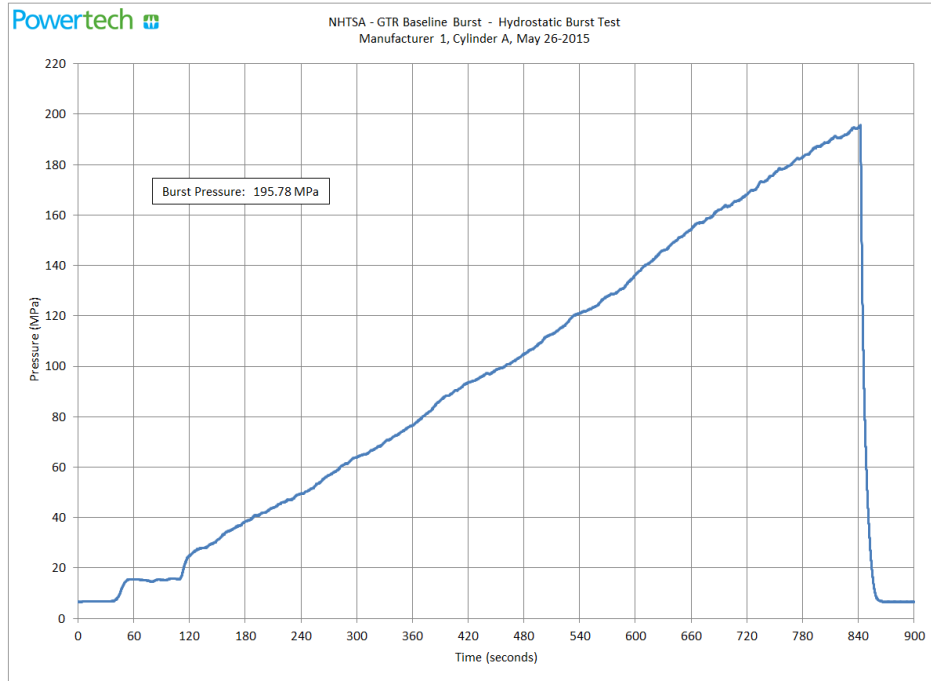

Figure 26. Baseline Burst Pressure Plot of Container 1-A

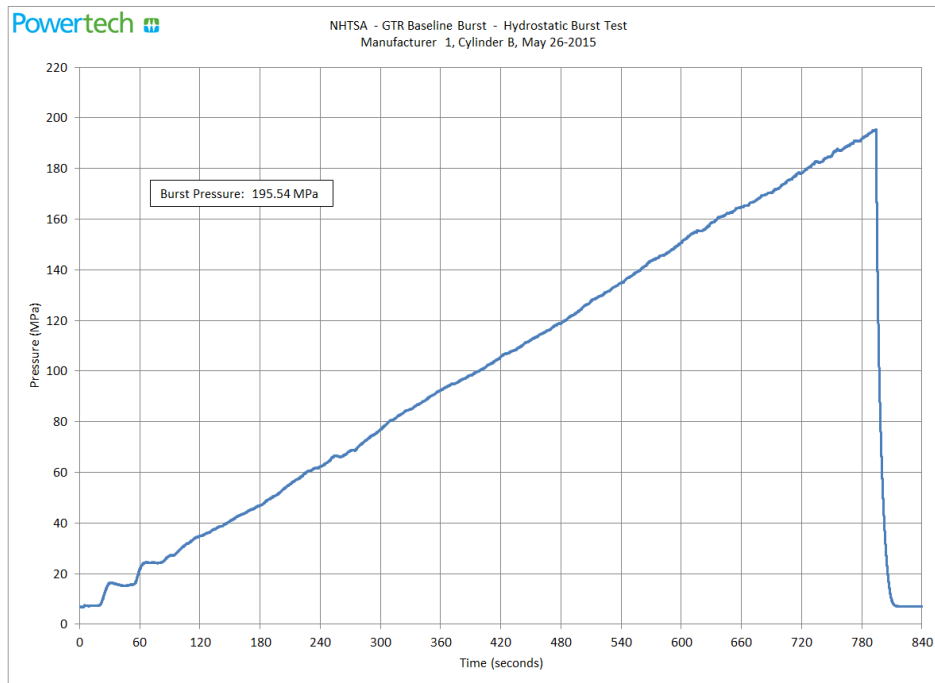

Figure 27. Baseline Burst Pressure Plot of Container 1-B

TEST REPORT

No. TR-00663-01-R2

December 7, 2017

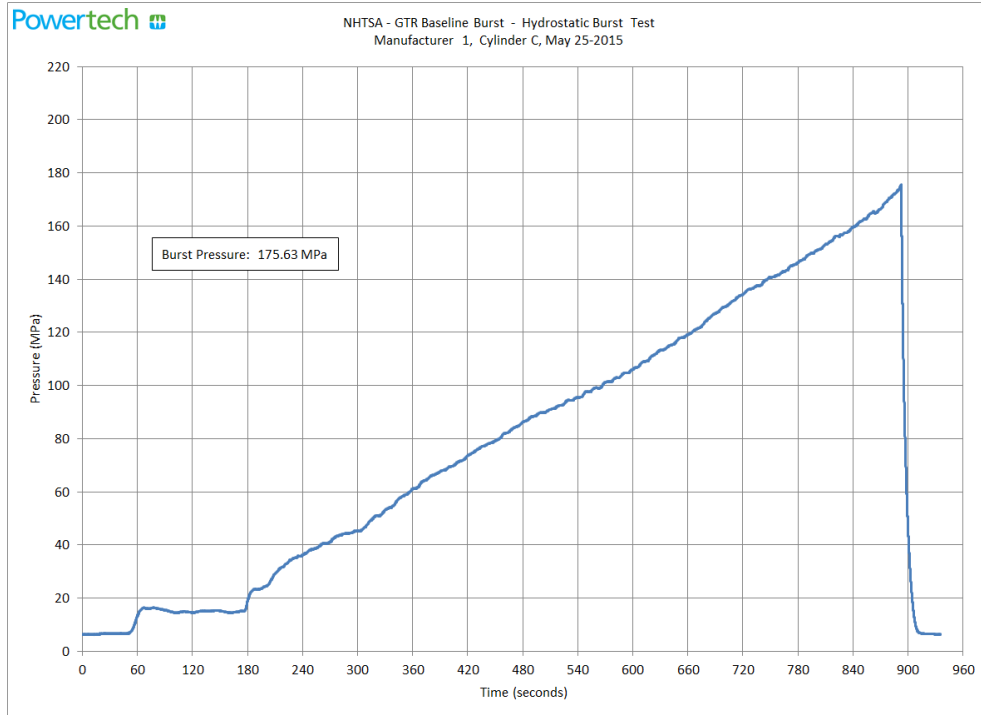

Figure 28. Baseline Burst Pressure Plot of Container 1-C

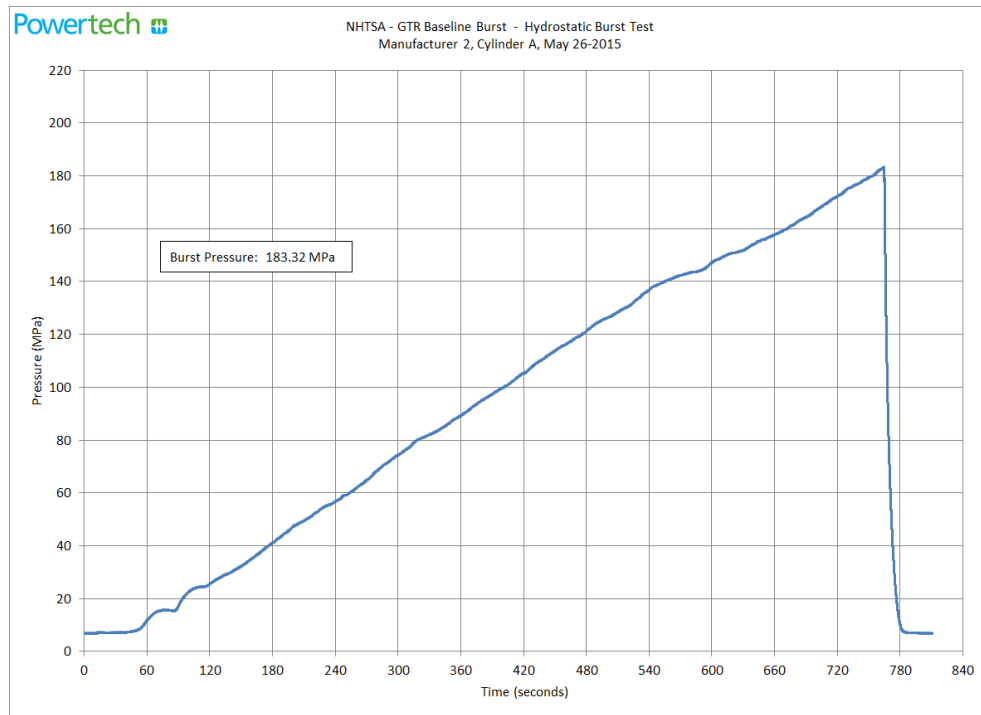

Figure 29. Baseline Burst Pressure Plot of Container 2-A

TEST REPORT

No. TR-00663-01-R2

December 7, 2017

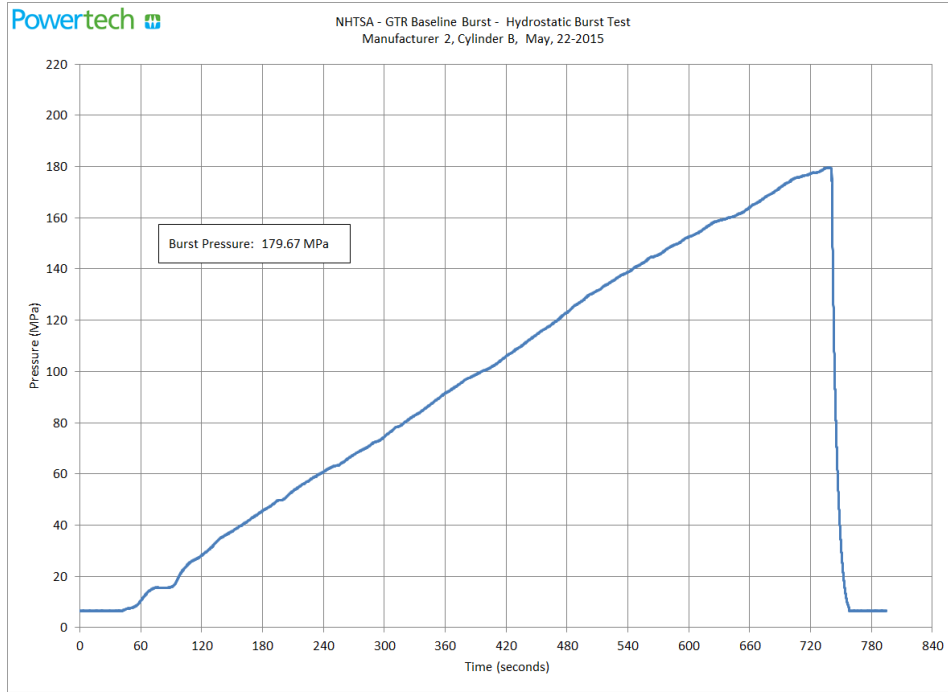

Figure 30. Baseline Burst Pressure Plot of Container 2-B

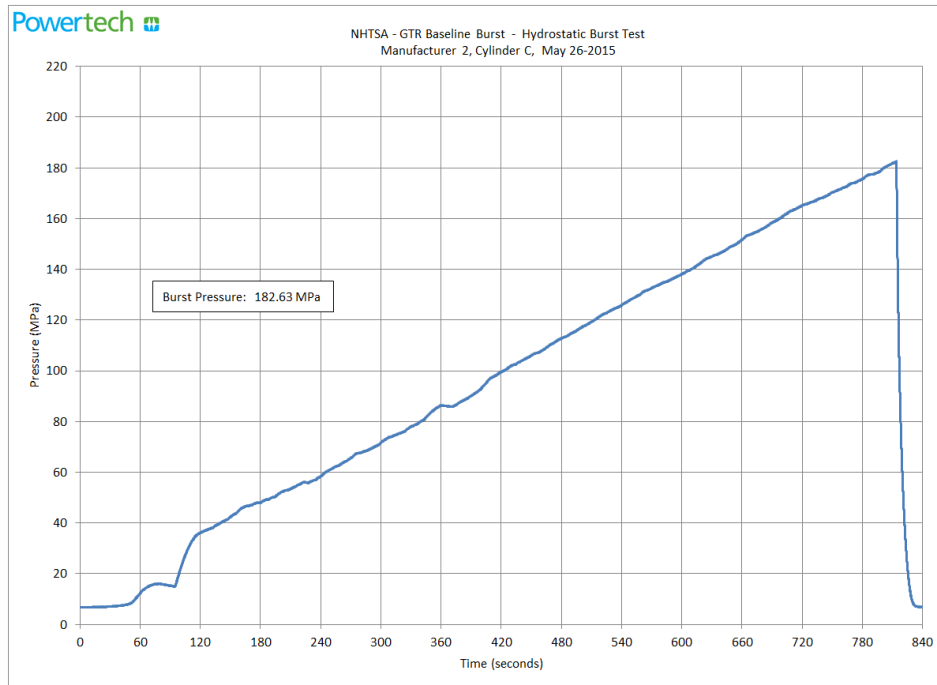

Figure 31. Baseline Burst Pressure Plot of Container 2-C

TEST REPORT

No. TR-00663-01-R2

December 7, 2017

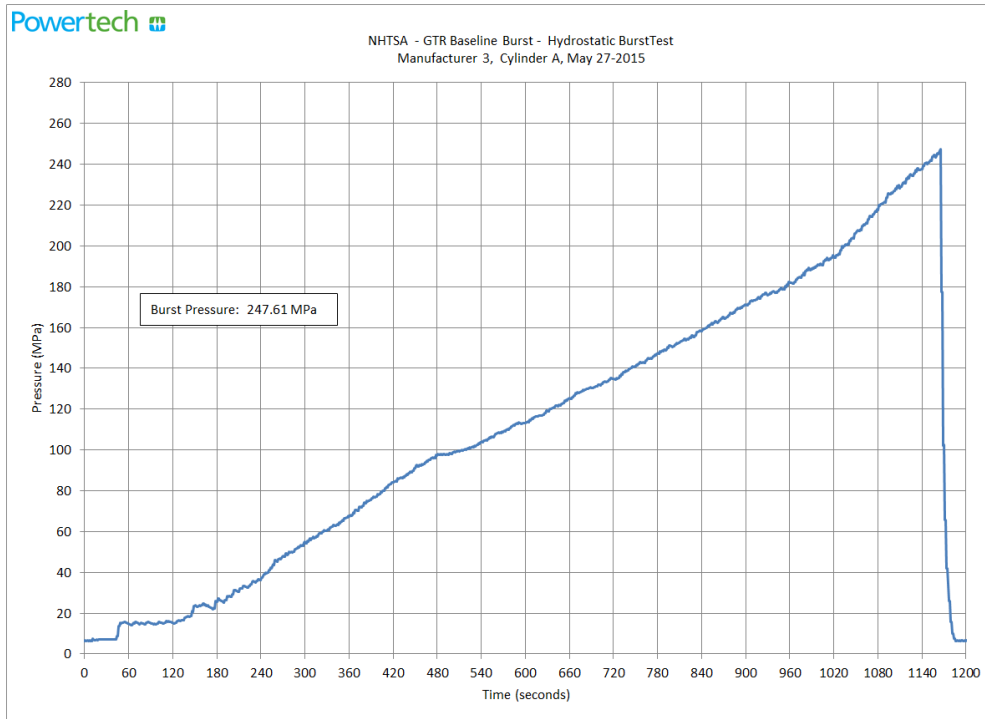

Figure 32. Baseline Burst Pressure Plot of Container 3-A

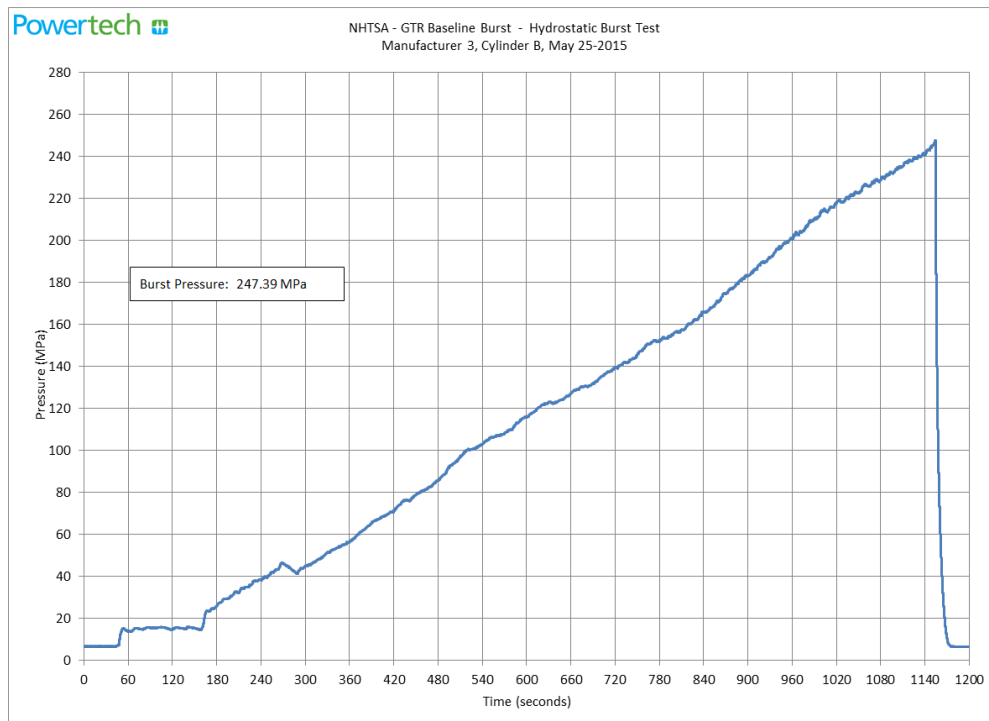

Figure 33. Baseline Burst Pressure Plot of Container 3-B

TEST REPORT

No. TR-00663-01-R2

December 7, 2017

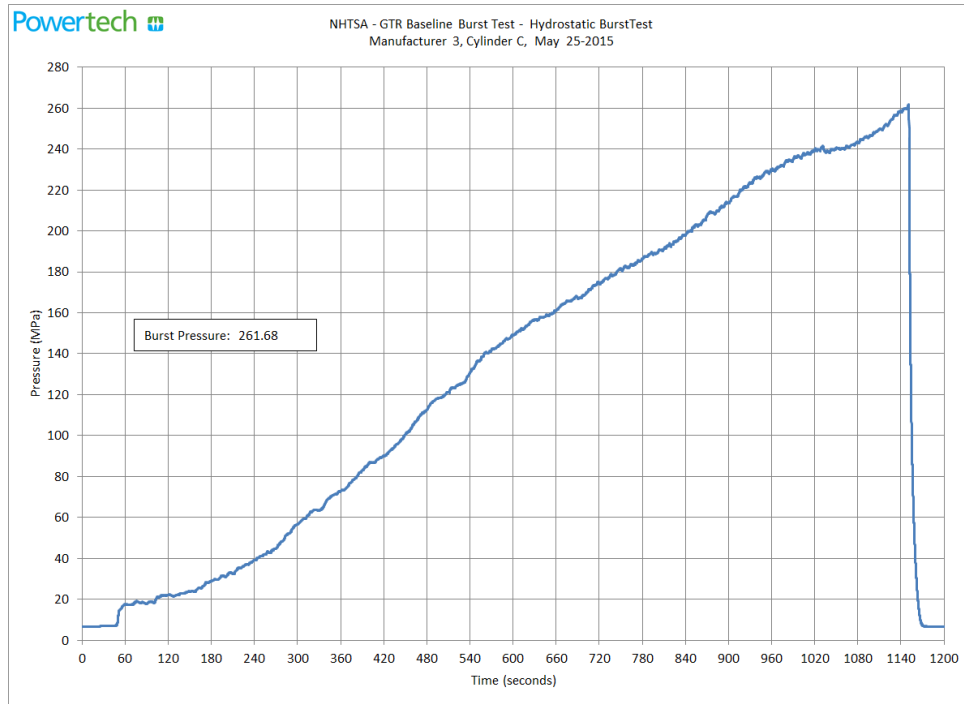

Figure 34. Baseline Burst Pressure Plot of Container 3-C

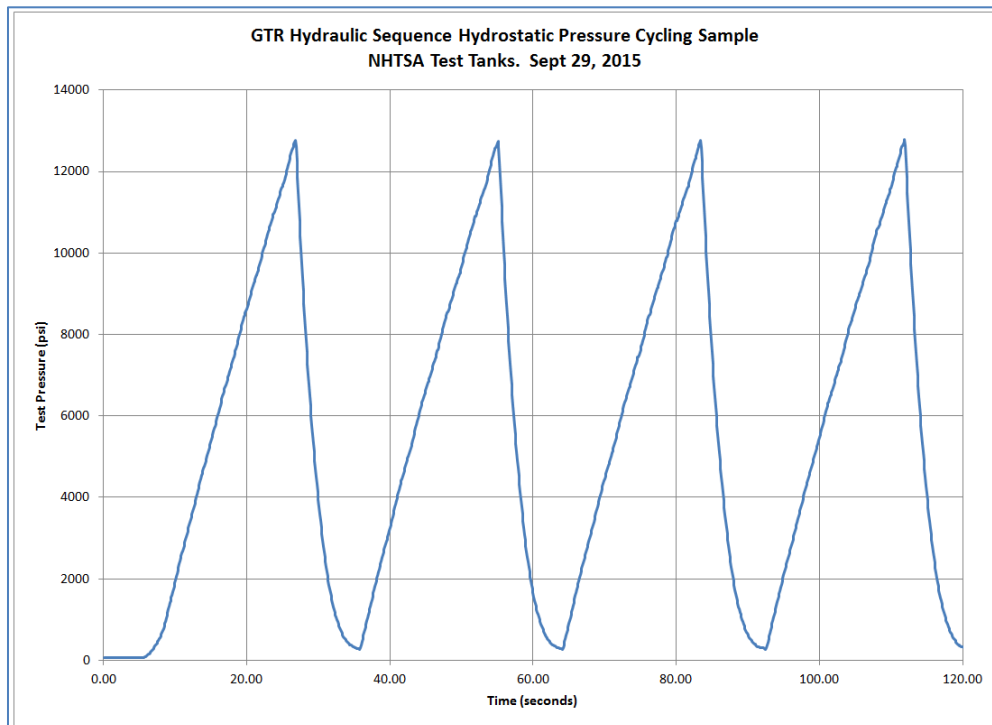

Figure 35. Hydraulic Sequence Ambient Pressure Cycling Profile

TEST REPORT

No. TR-00663-01-R2

December 7, 2017

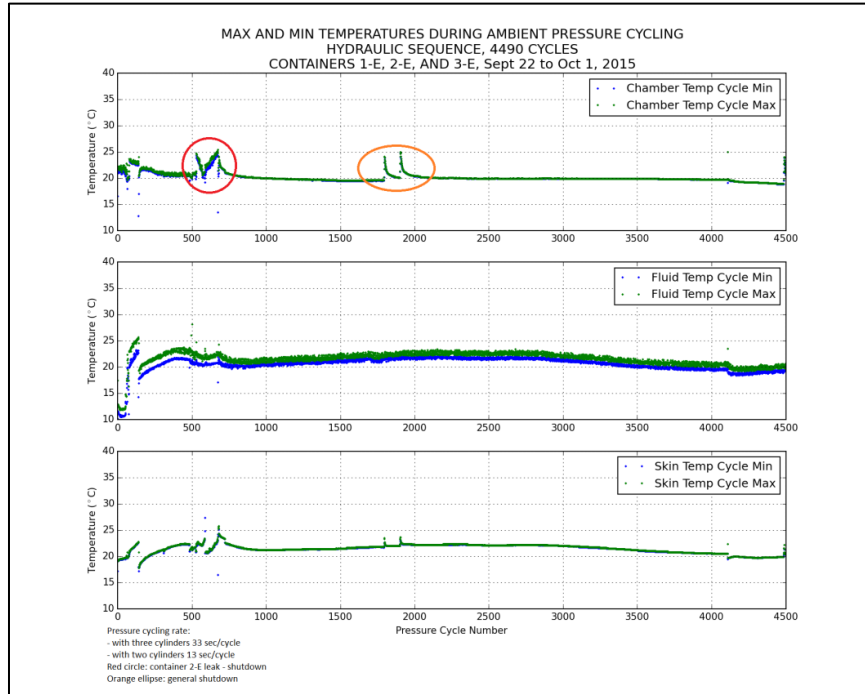

Figure 36. Max and Min Temperatures during ChemEx Ambient Cycles to 1.25xNWP

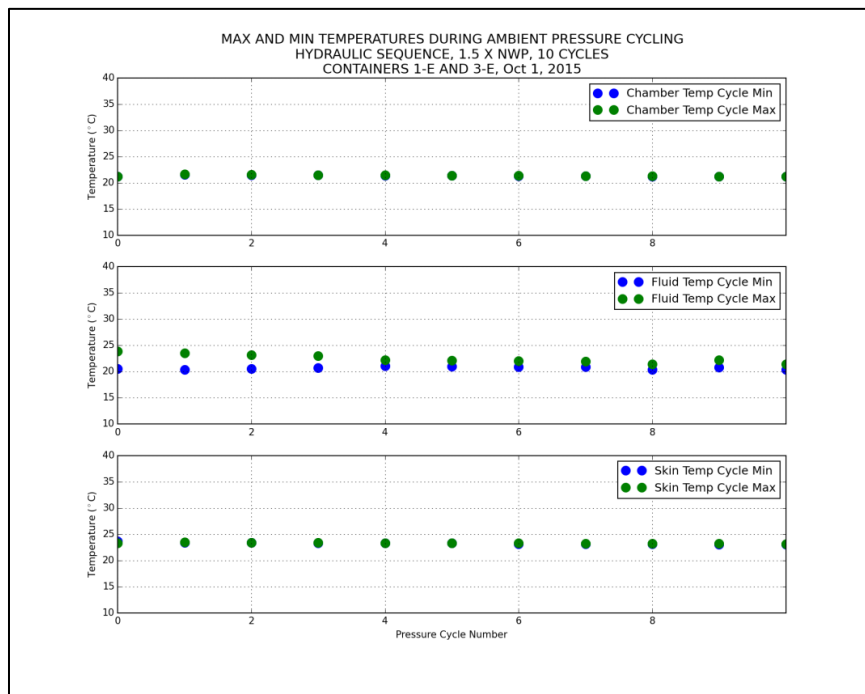

Figure 37. Max and Min Temperatures during last 10 ChemEx Ambient Cycles to 1.5 x NWP

TEST REPORT

No. TR-00663-01-R2

December 7, 2017

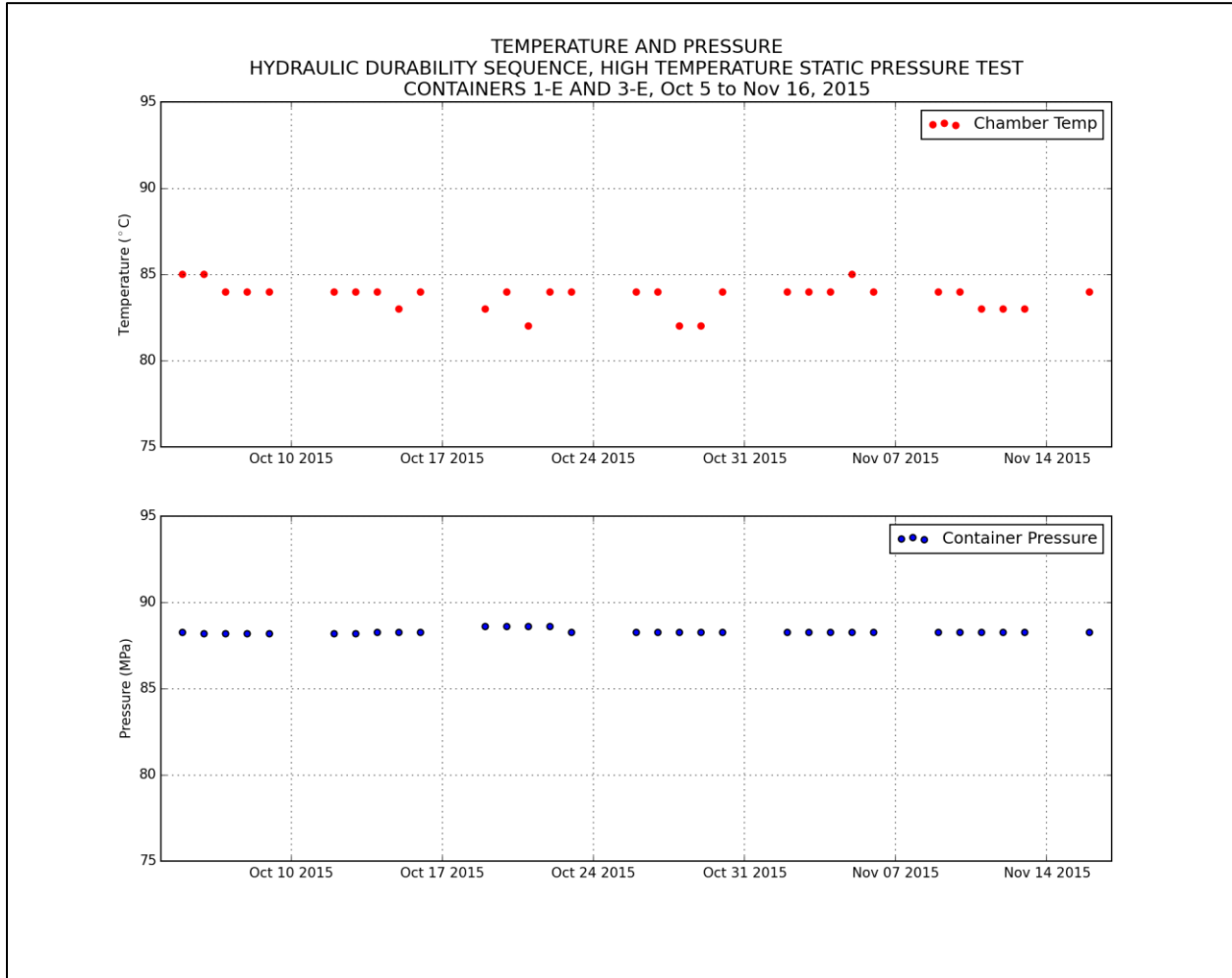

Figure 38. Temperatures and pressures during high temperature static pressure sequence

TEST REPORT

No. TR-00663-01-R2

December 7, 2017

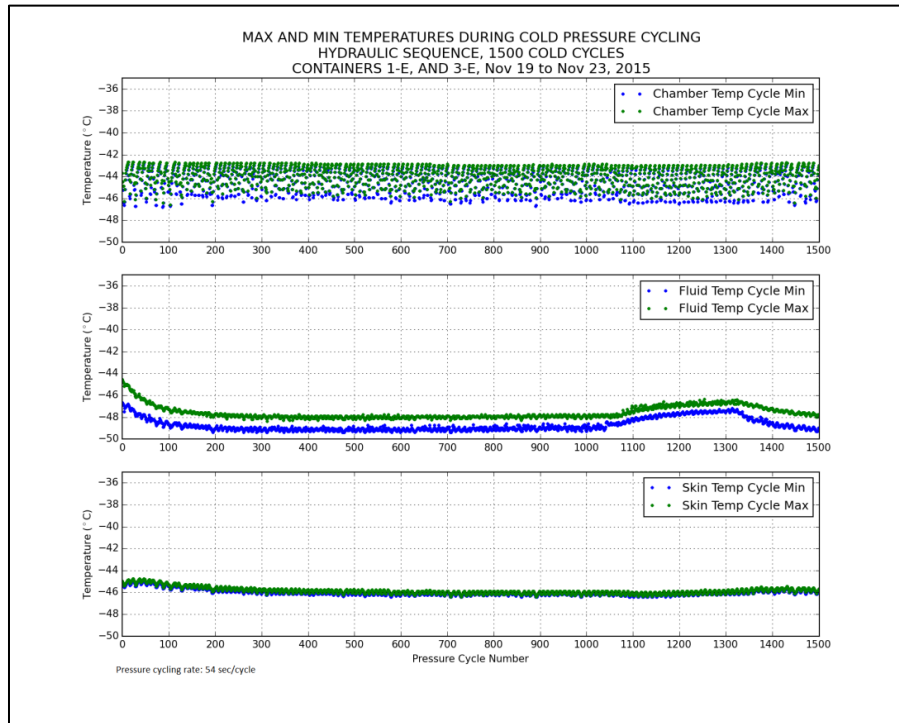

Figure 39. Temperatures recorded during cold pressure cycling

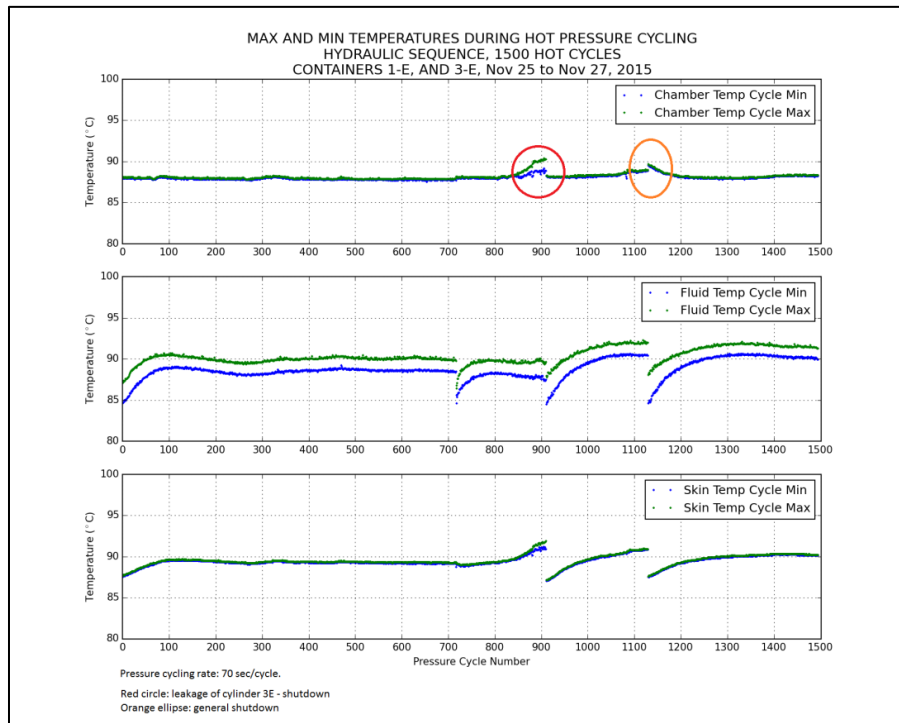

Figure 40. Temperatures recorded during hot pressure cycling

TEST REPORT

No. TR-00663-01-R2

December 7, 2017

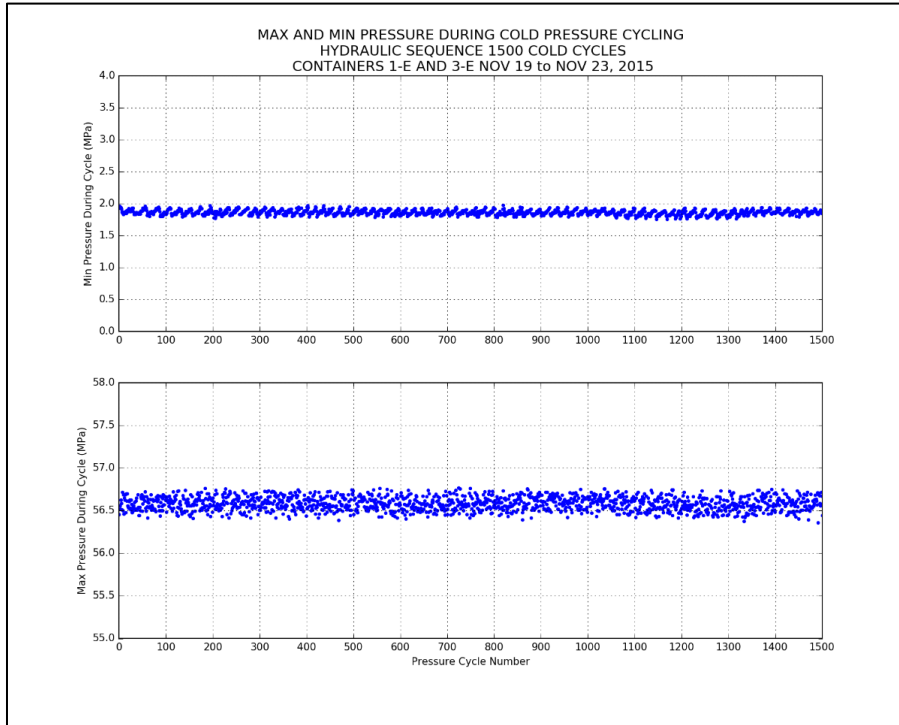

Figure 41. Max and min pressures recorded during cold pressure cycling

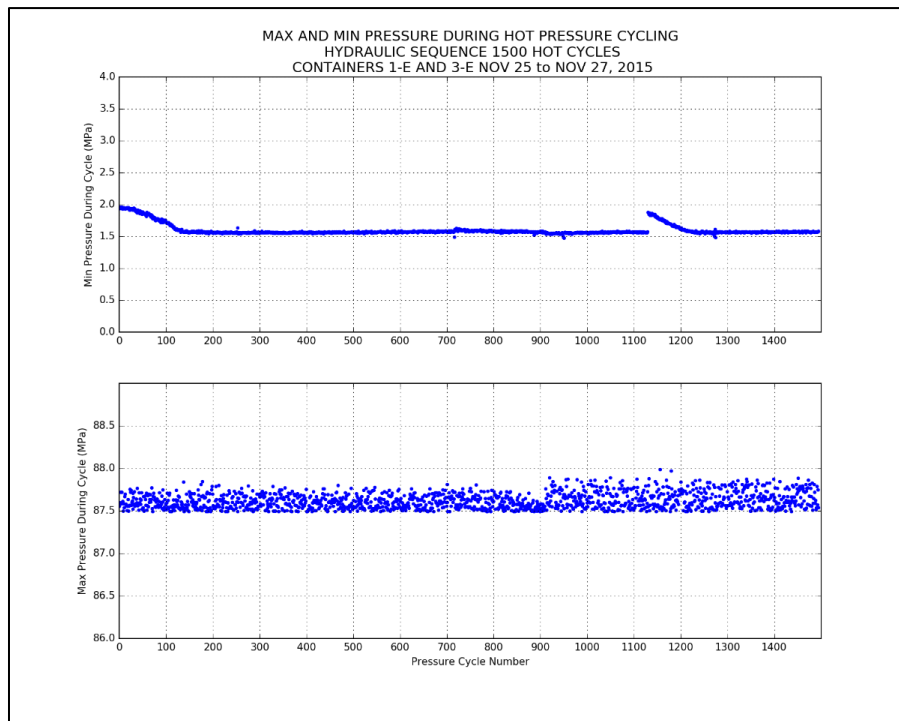

Figure 42. Max and min pressures recorded during hot pressure cycling

TEST REPORT

No. TR-00663-01-R2

December 7, 2017

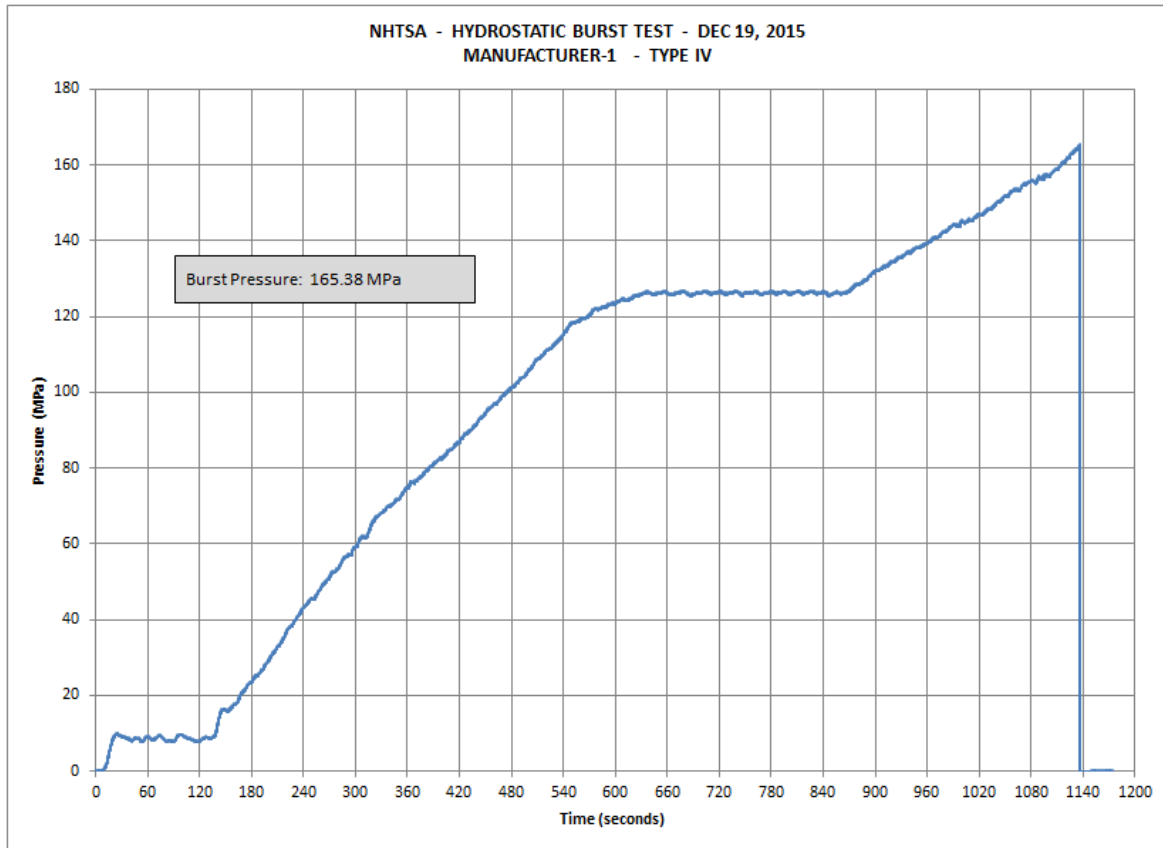

Figure 43. Hydraulic Sequence Burst Test - Pressure Plot of Container 1-E

TEST REPORT

No. TR-00663-01-R2

December 7, 2017

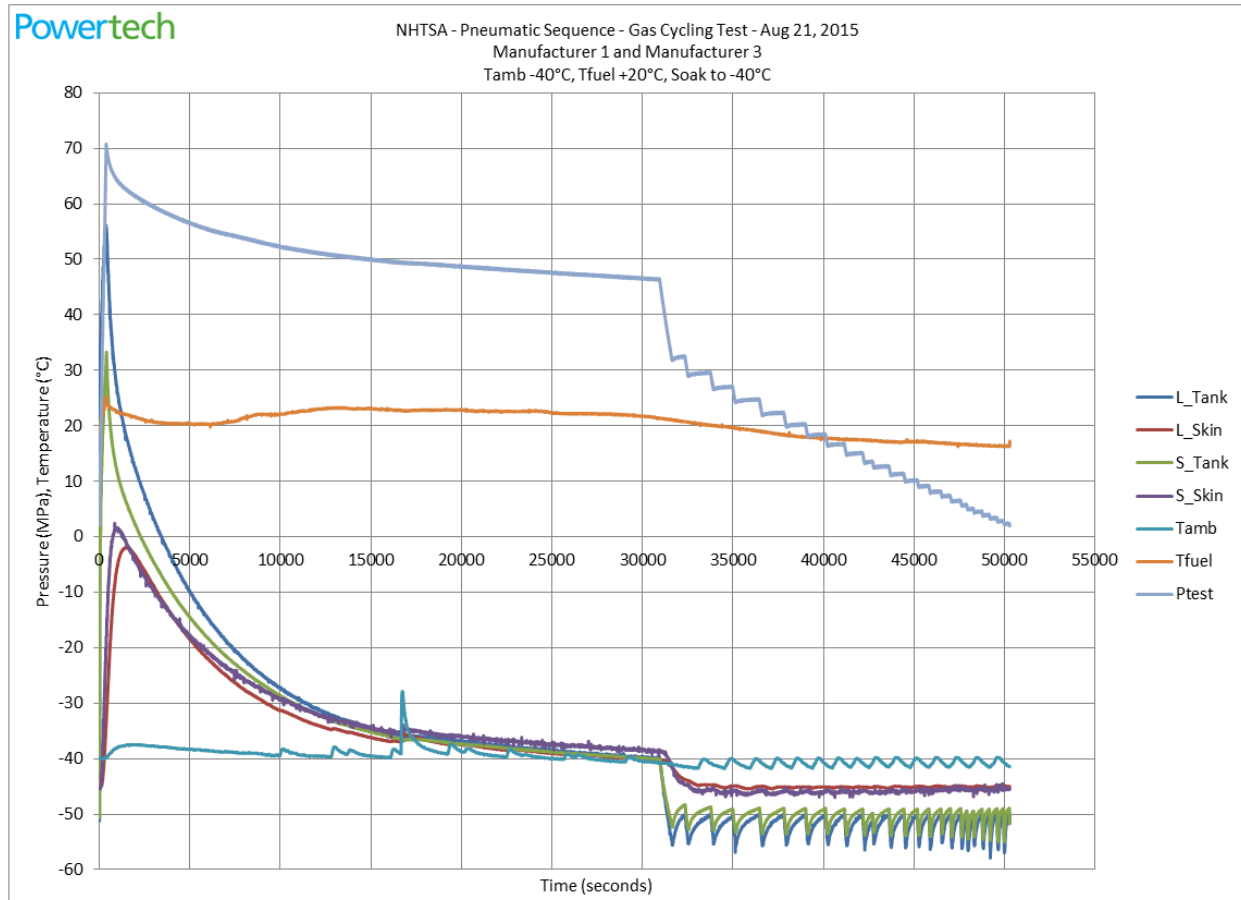

Figure 44. Gas Cycling Test Stage 1 – cold soak cycles with 20°C fuel delivery temperature, full cycle

TEST REPORT

No. TR-00663-01-R2

December 7, 2017

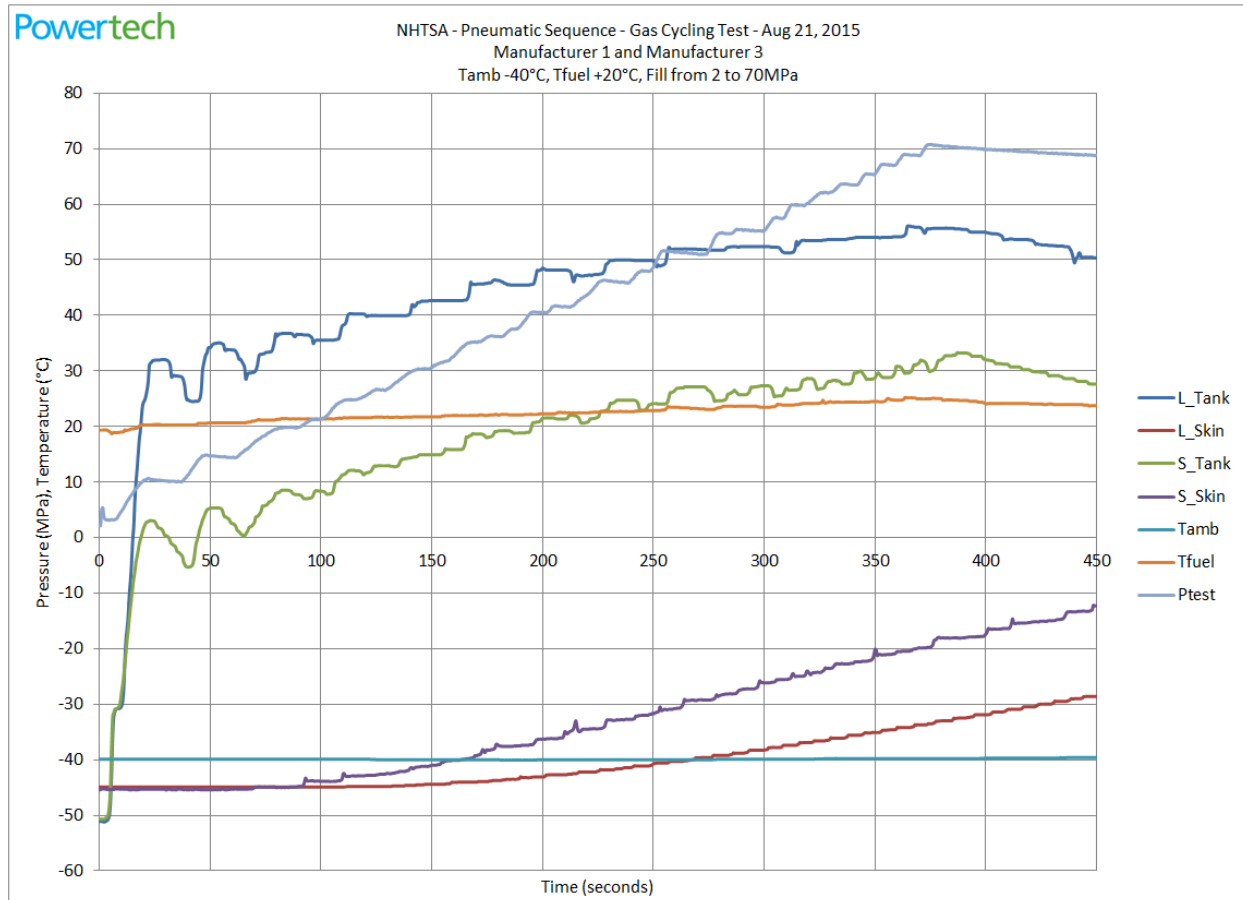

Figure 45. Gas Cycling Test Stage 1 – cold soak cycles with 20°C fuel delivery temperature, fill profile

TEST REPORT

No. TR-00663-01-R2

December 7, 2017

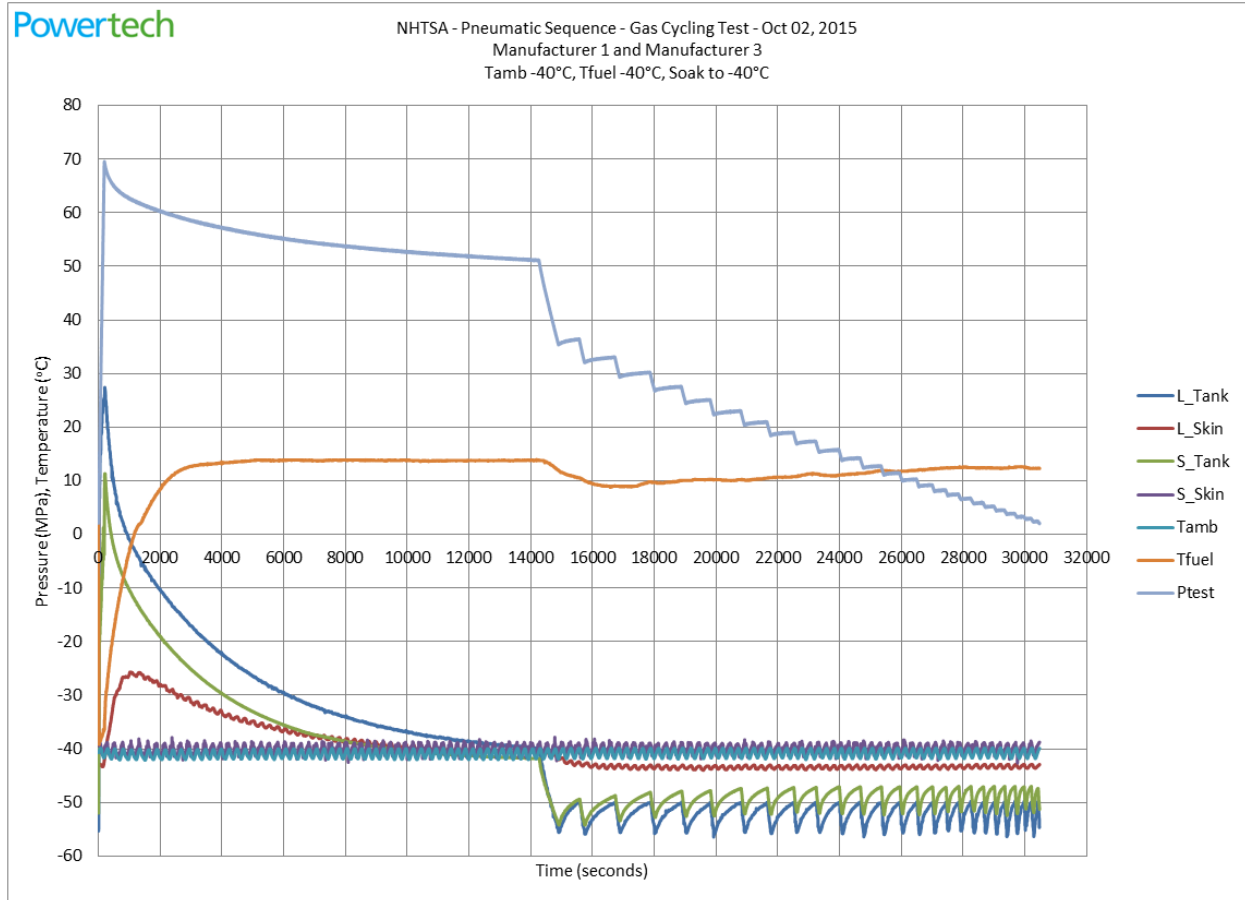

Figure 46. Gas Cycling Test Stage 2 – cold soak cycles with -40°C fuel delivery temperature, full cycle

TEST REPORT

No. TR-00663-01-R2

December 7, 2017

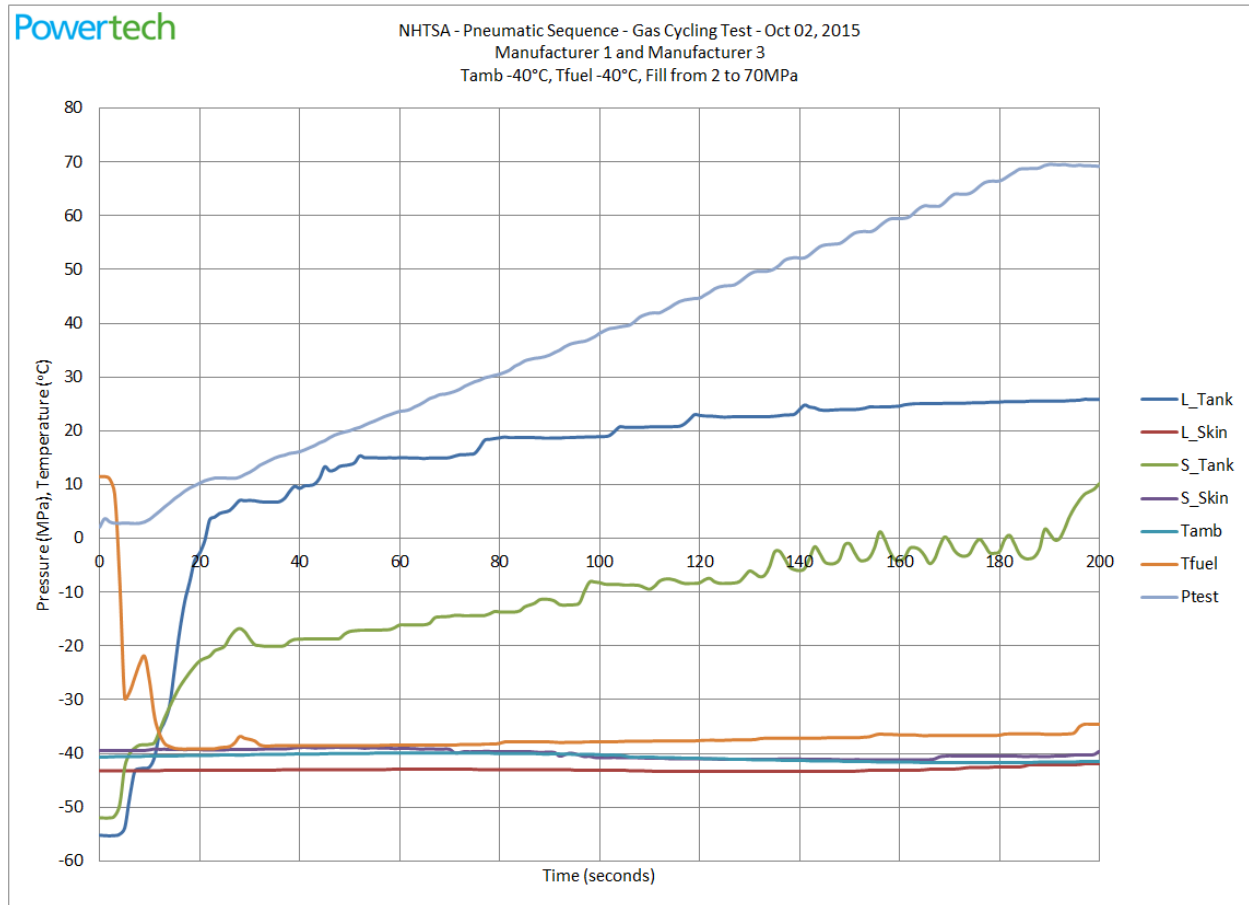

Figure 47. Gas Cycling Test Stage 2 – cold soak cycles with -40°C fuel delivery temperature, fill profile

TEST REPORT

No. TR-00663-01-R2

December 7, 2017

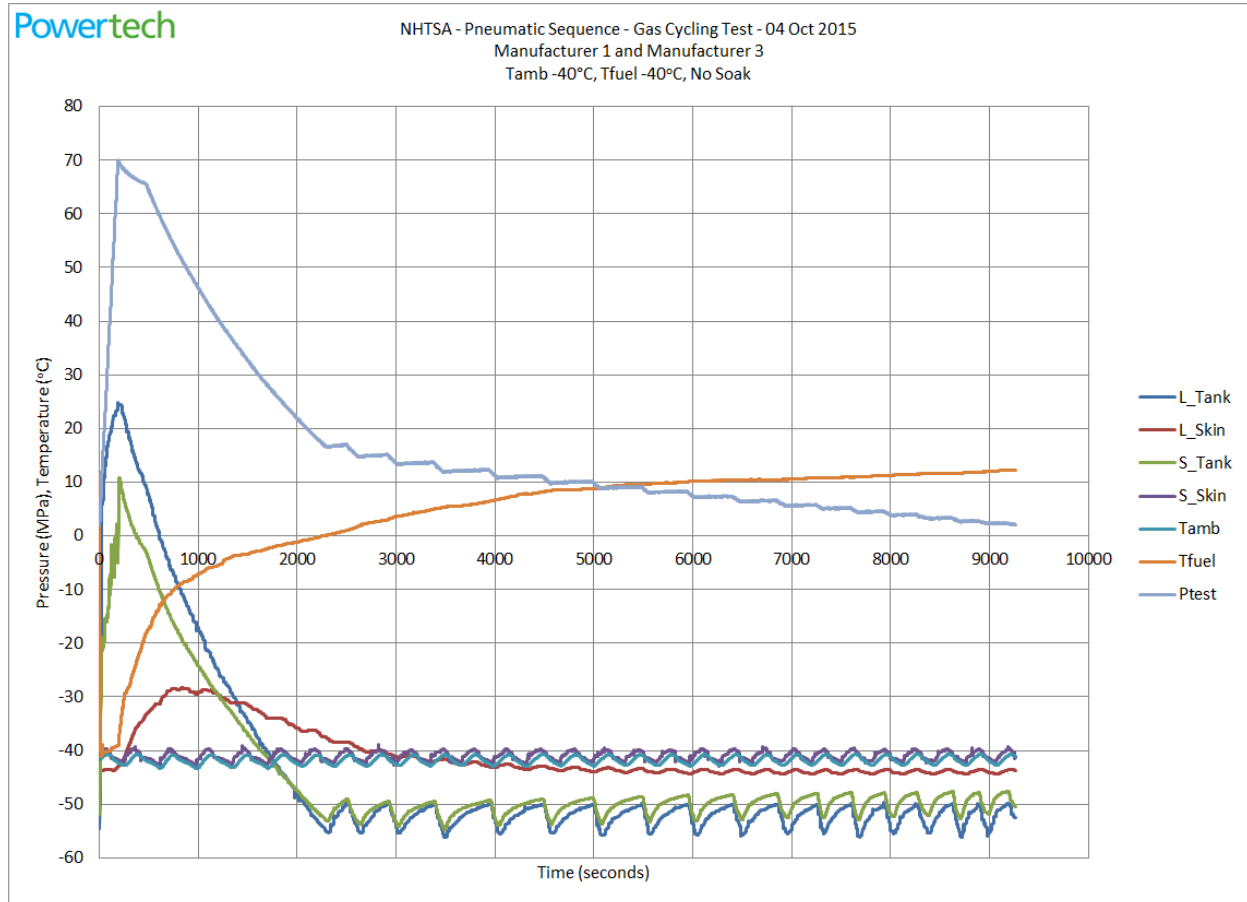

Figure 48. Gas Cycling Test Stage 3 – cold cycles, full cycle

TEST REPORT

No. TR-00663-01-R2

December 7, 2017

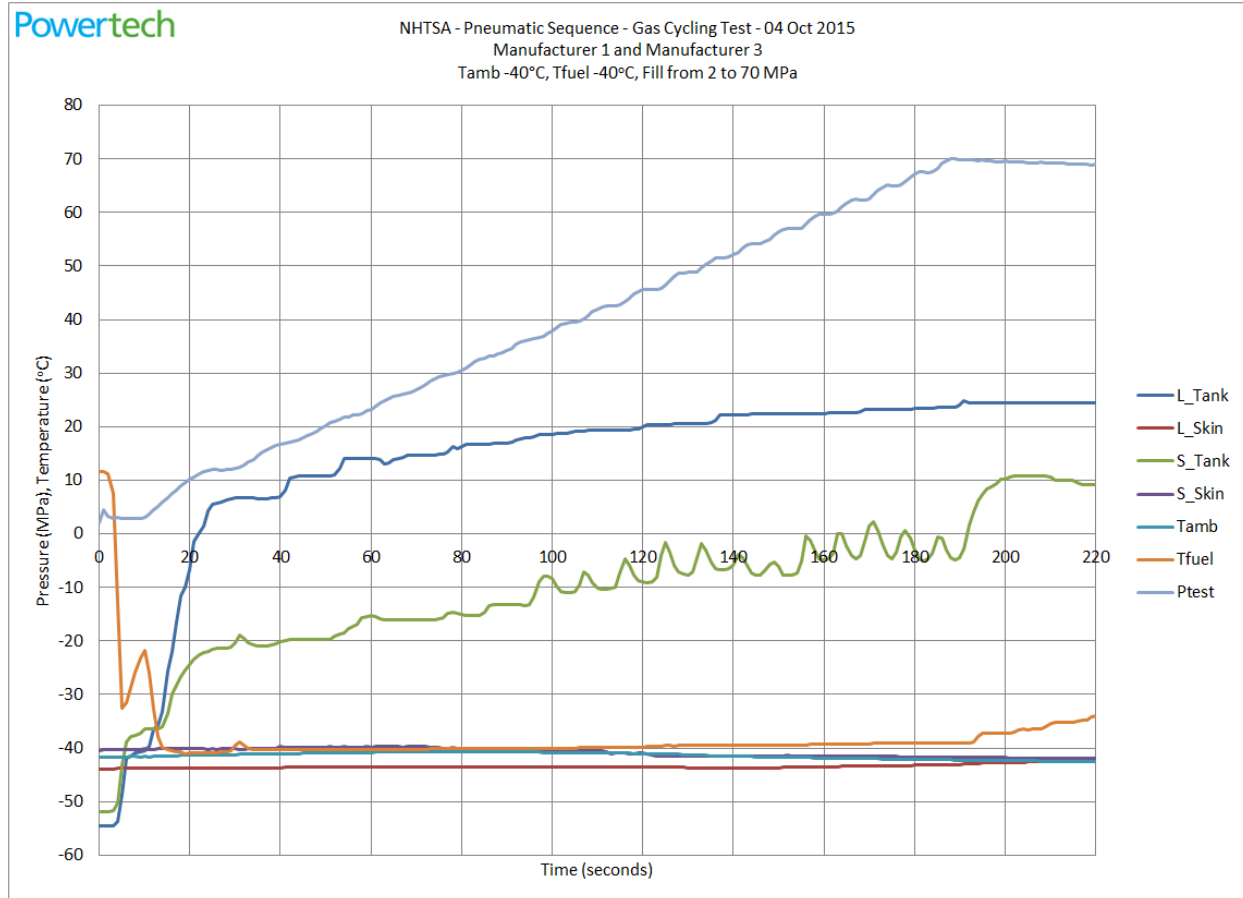

Figure 49. Gas Cycling Test Stage 3 – cold cycles, fill profile

TEST REPORT

No. TR-00663-01-R2

December 7, 2017

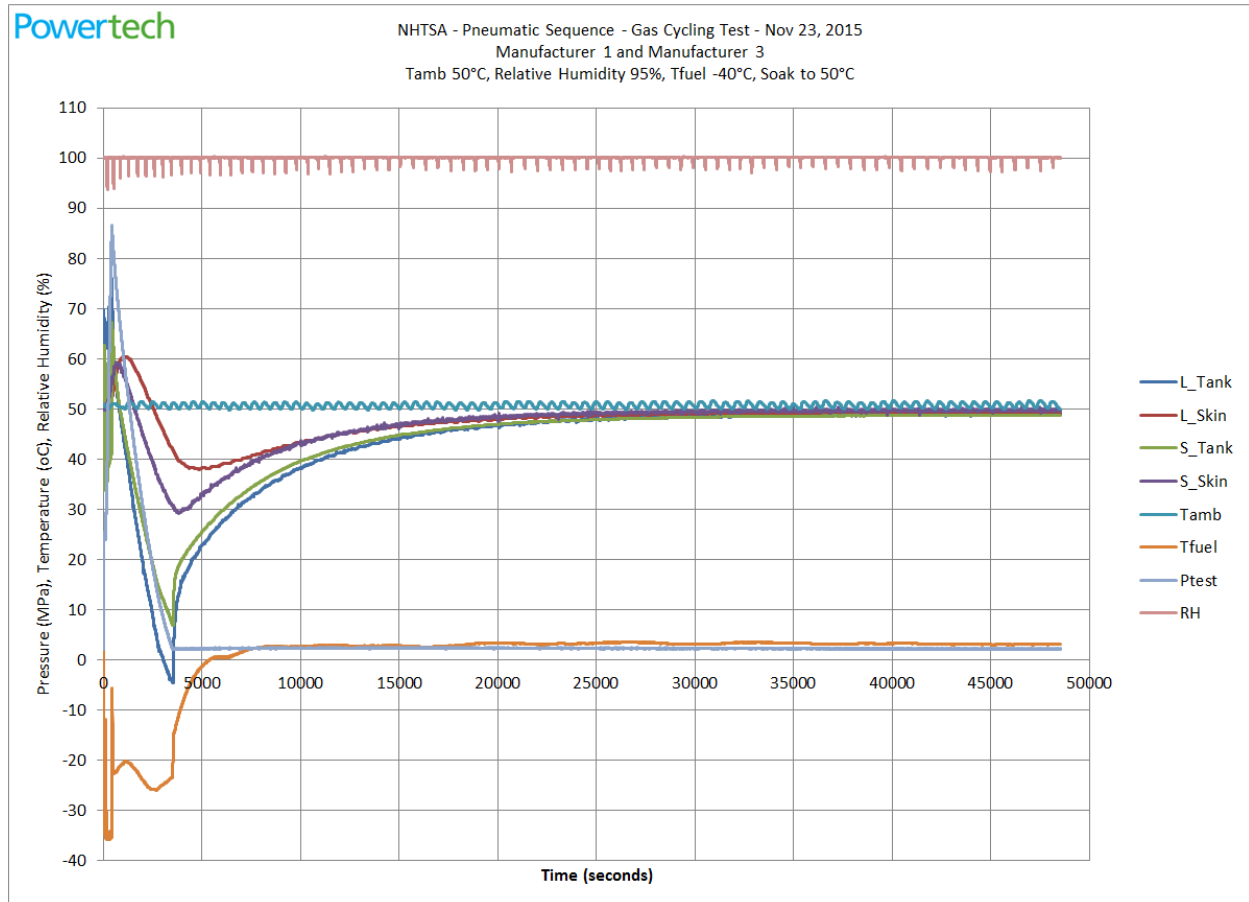

Figure 50. Gas Cycling Test Stage 4 – hot soak cycles, full cycle

TEST REPORT

No. TR-00663-01-R2

December 7, 2017

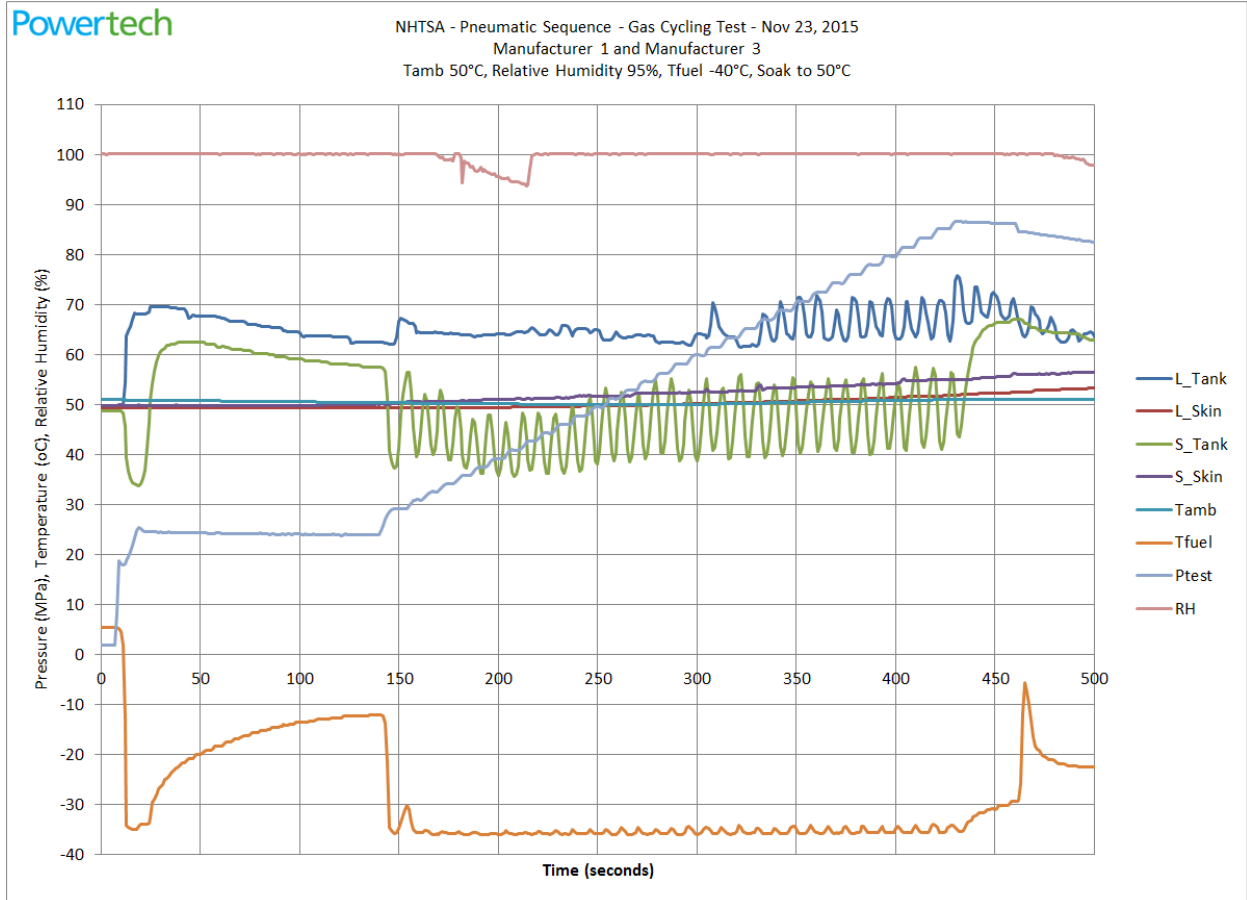

Figure 51. Gas Cycling Test Stage 4 – hot soak cycles, fill profile

TEST REPORT

No. TR-00663-01-R2

December 7, 2017

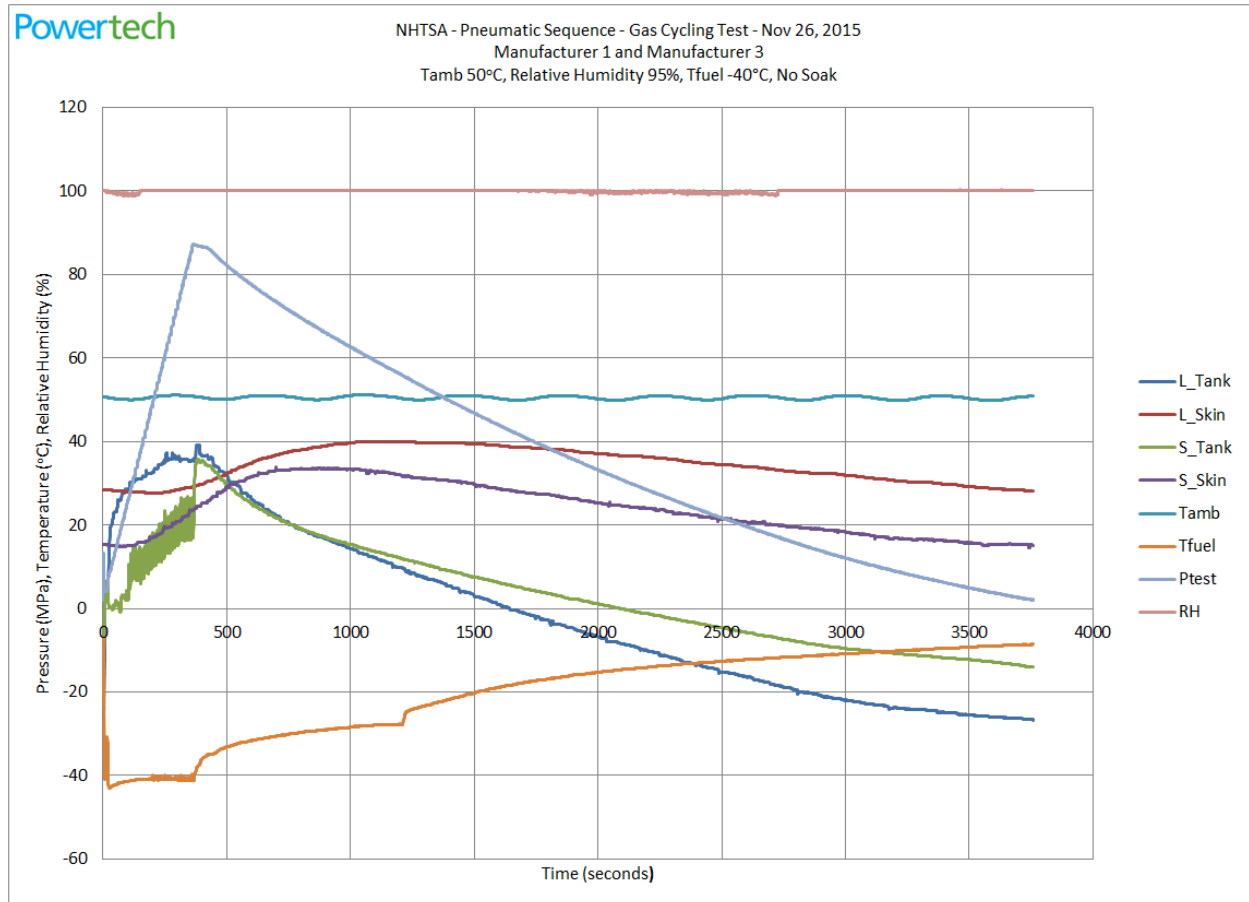

Figure 52. Gas Cycling Test Stage 5 – hot cycles, full cycle

TEST REPORT

No. TR-00663-01-R2

December 7, 2017

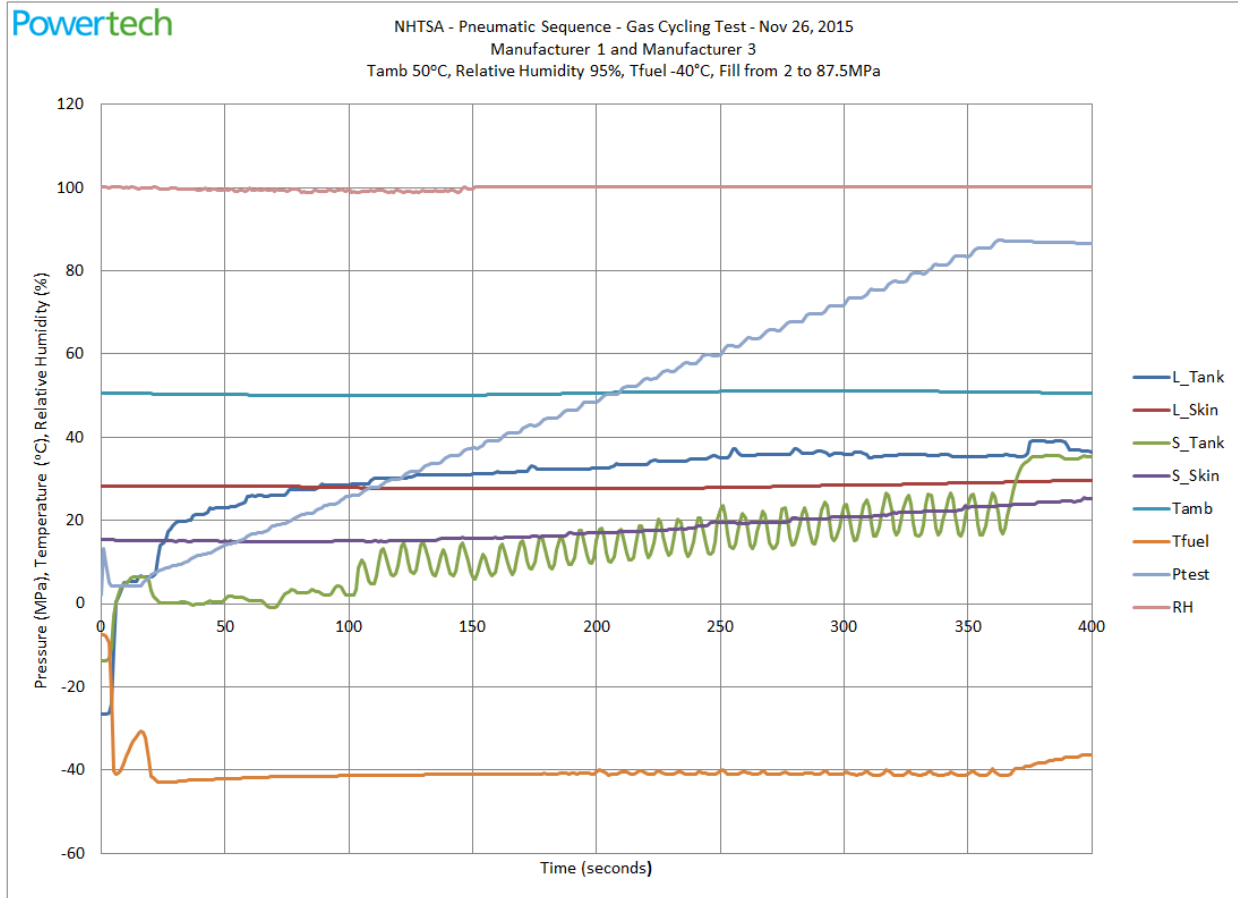

Figure 53. Gas Cycling Test Stage 5 – hot cycles, fill profile

TEST REPORT

No. TR-00663-01-R2

December 7, 2017

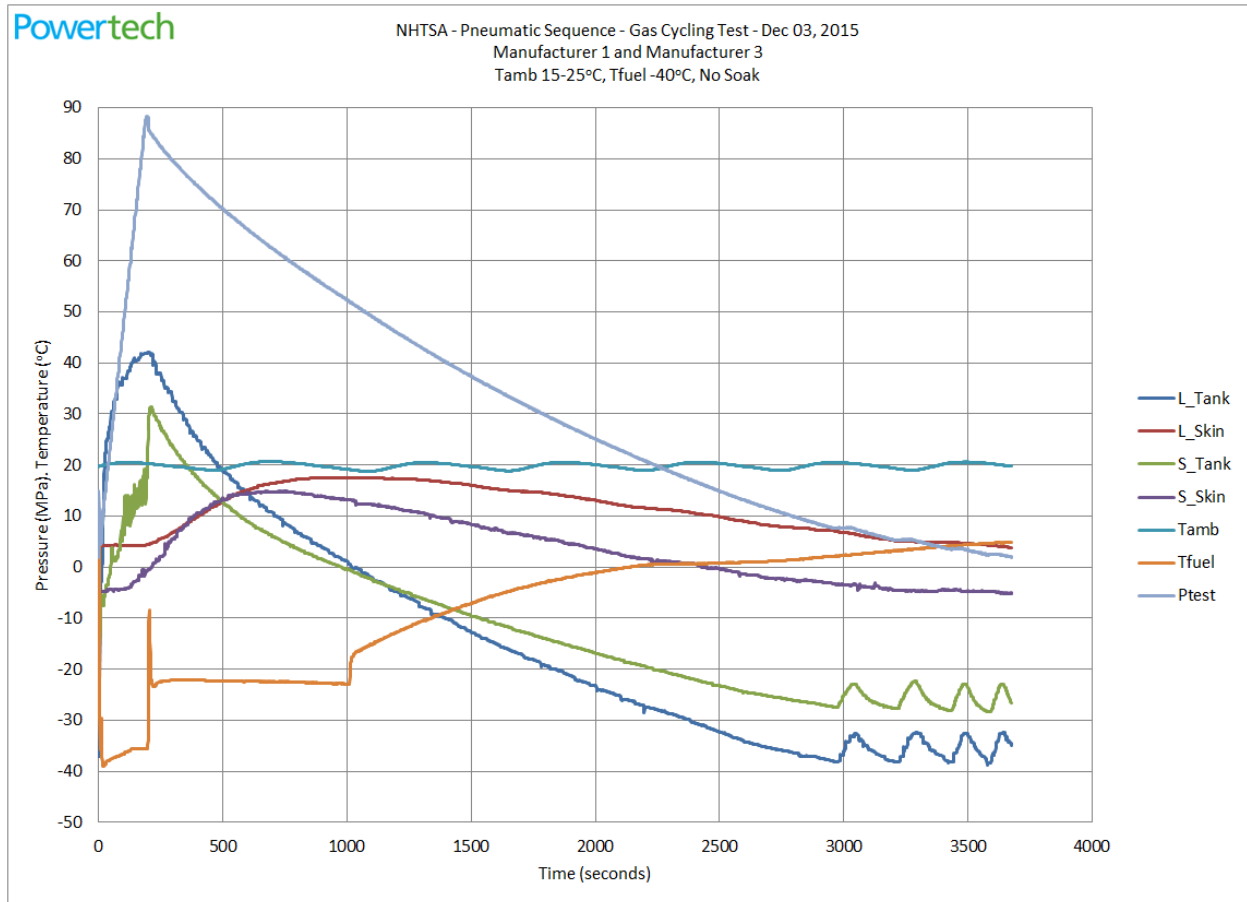

Figure 54. Gas Cycling Test Stage 6 – ambient cycles, full cycle

TEST REPORT

No. TR-00663-01-R2

December 7, 2017

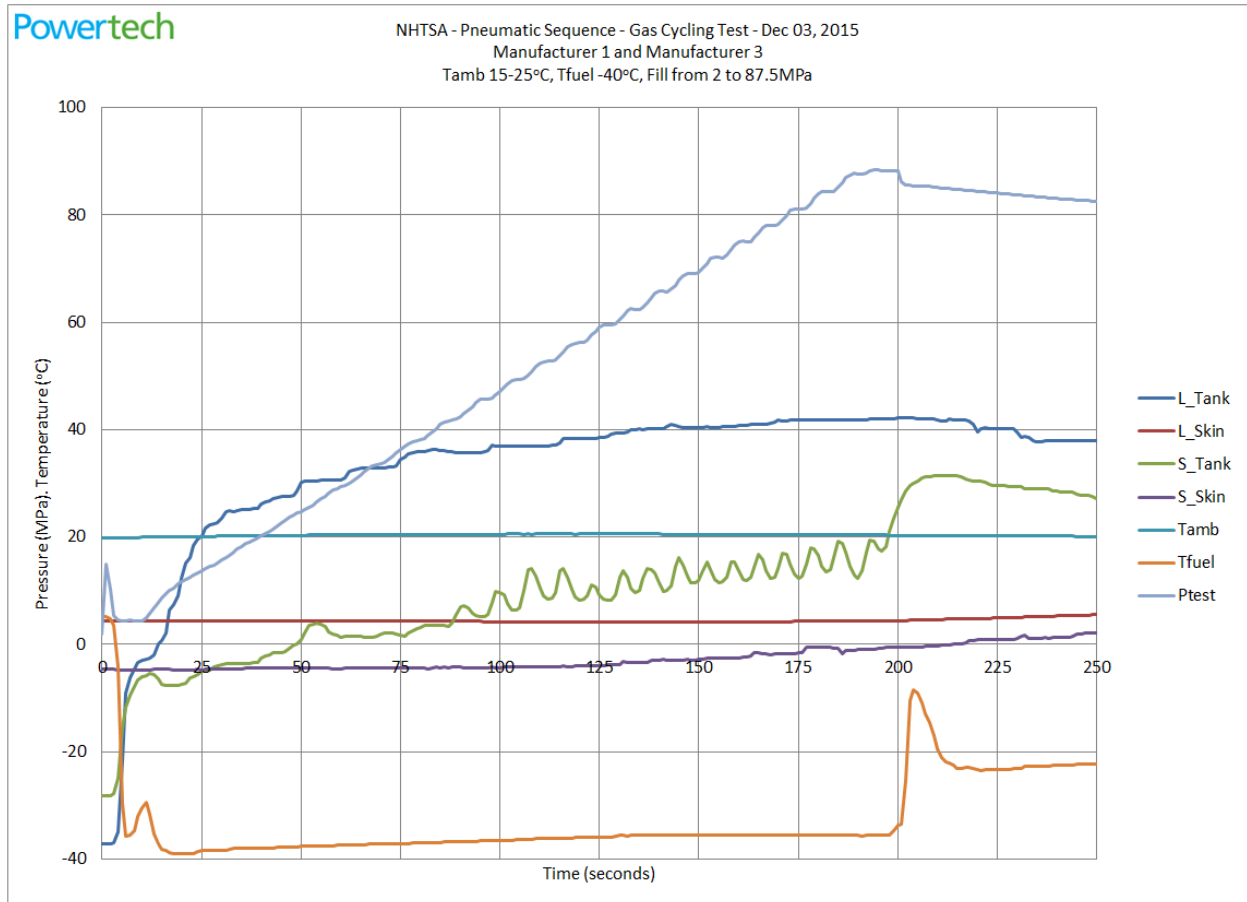

Figure 55. Gas Cycling Test Stage 6 – ambient cycles, fill profile

TEST REPORT

No. TR-00663-01-R2

December 7, 2017

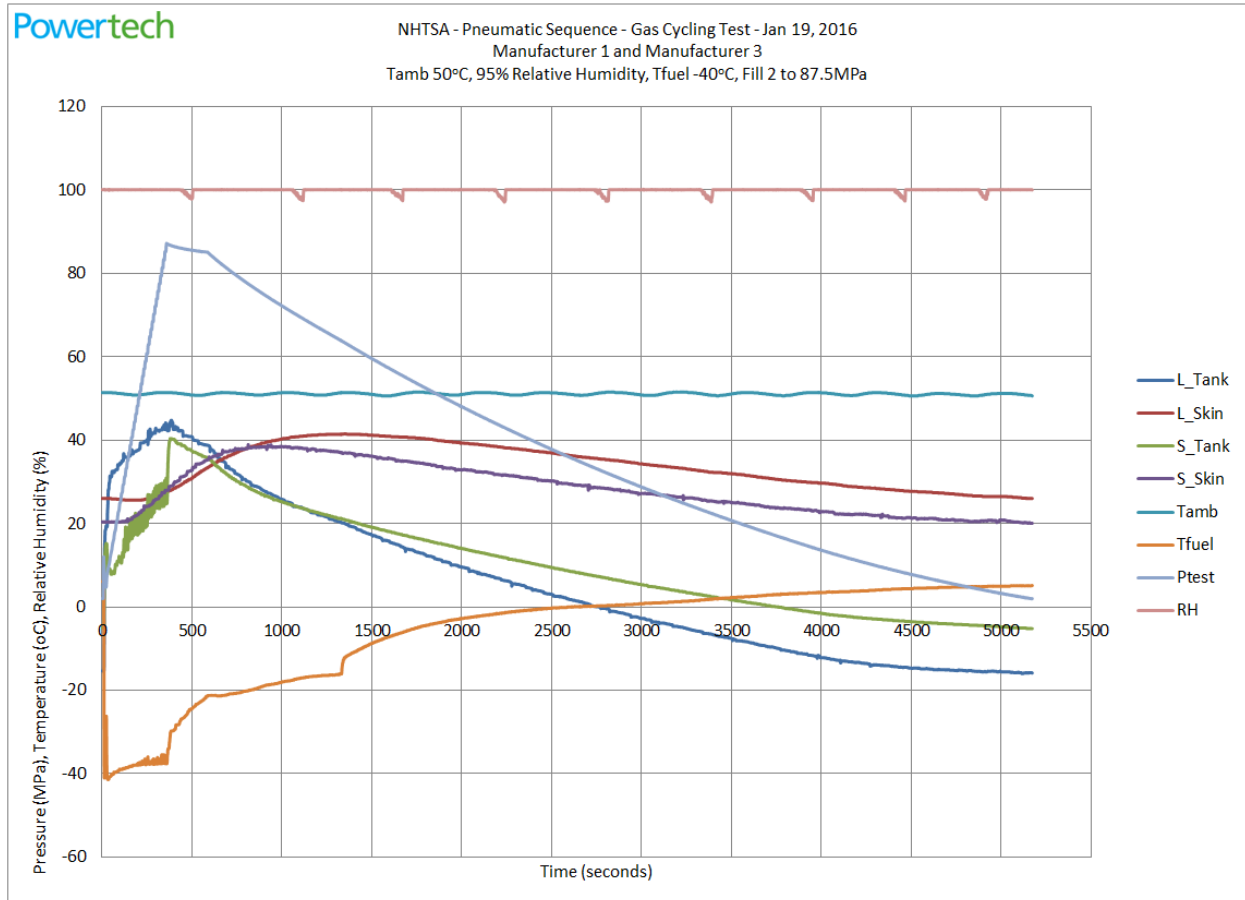

Figure 56. Gas Cycling Test Stage 8 – hot cycles, full cycle

TEST REPORT

No. TR-00663-01-R2

December 7, 2017

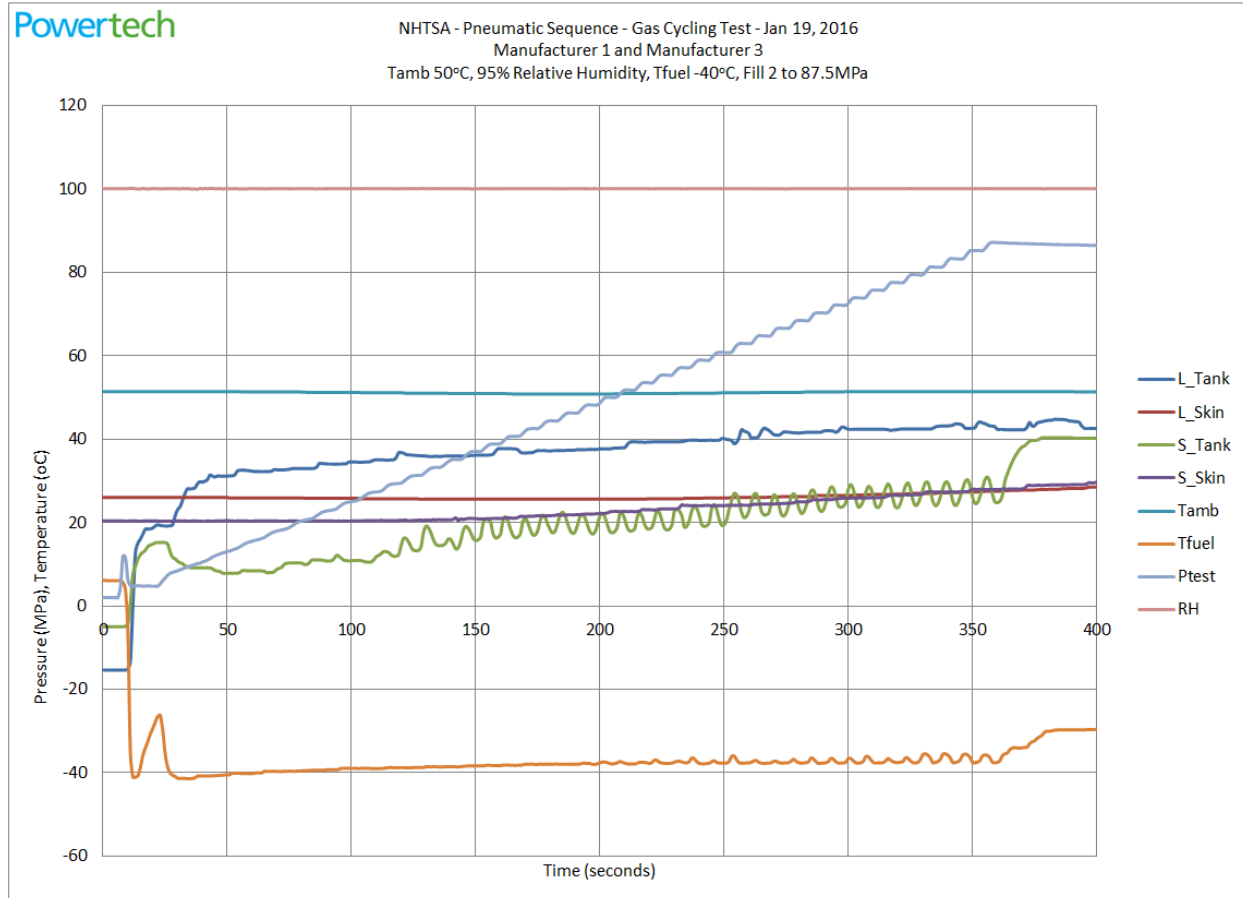

Figure 57. Gas Cycling Test Stage 8 – hot cycles, fill profile

TEST REPORT

No. TR-00663-01-R2

December 7, 2017

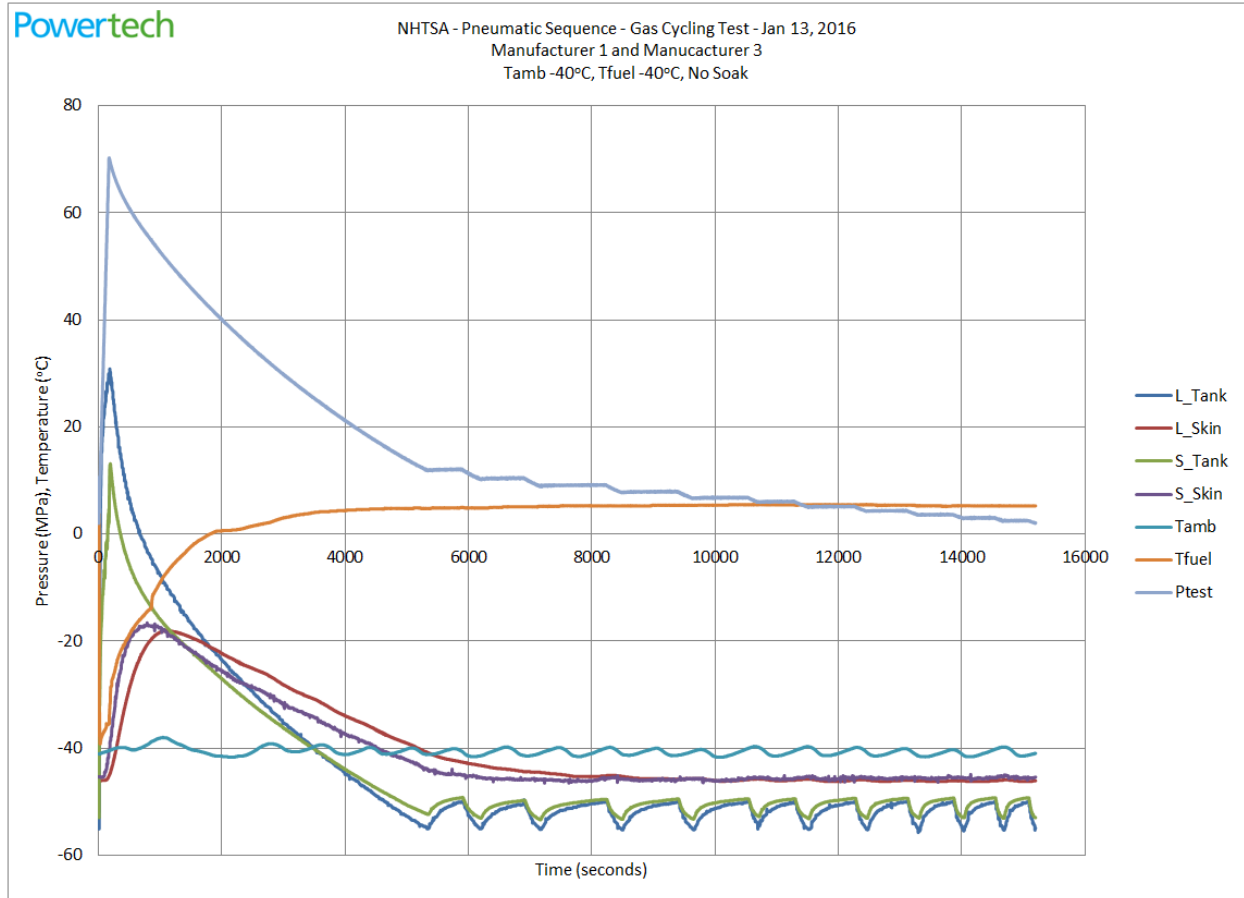

Figure 58. Gas Cycling Test Stage 9 – cold cycles, full cycle

TEST REPORT

No. TR-00663-01-R2

December 7, 2017

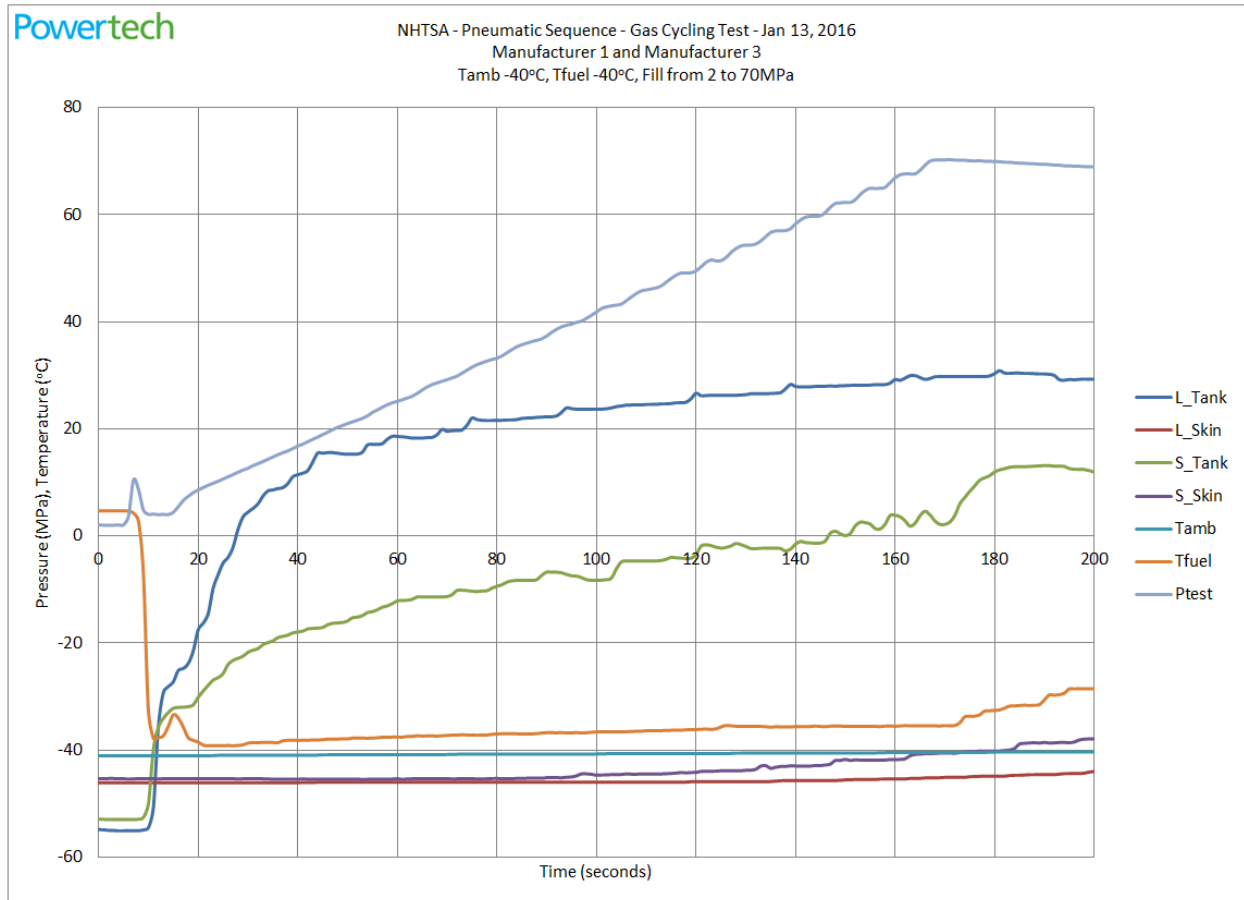

Figure 59. Gas Cycling Test Stage 9 – cold cycles, fill profile

TEST REPORT

No. TR-00663-01-R2

December 7, 2017

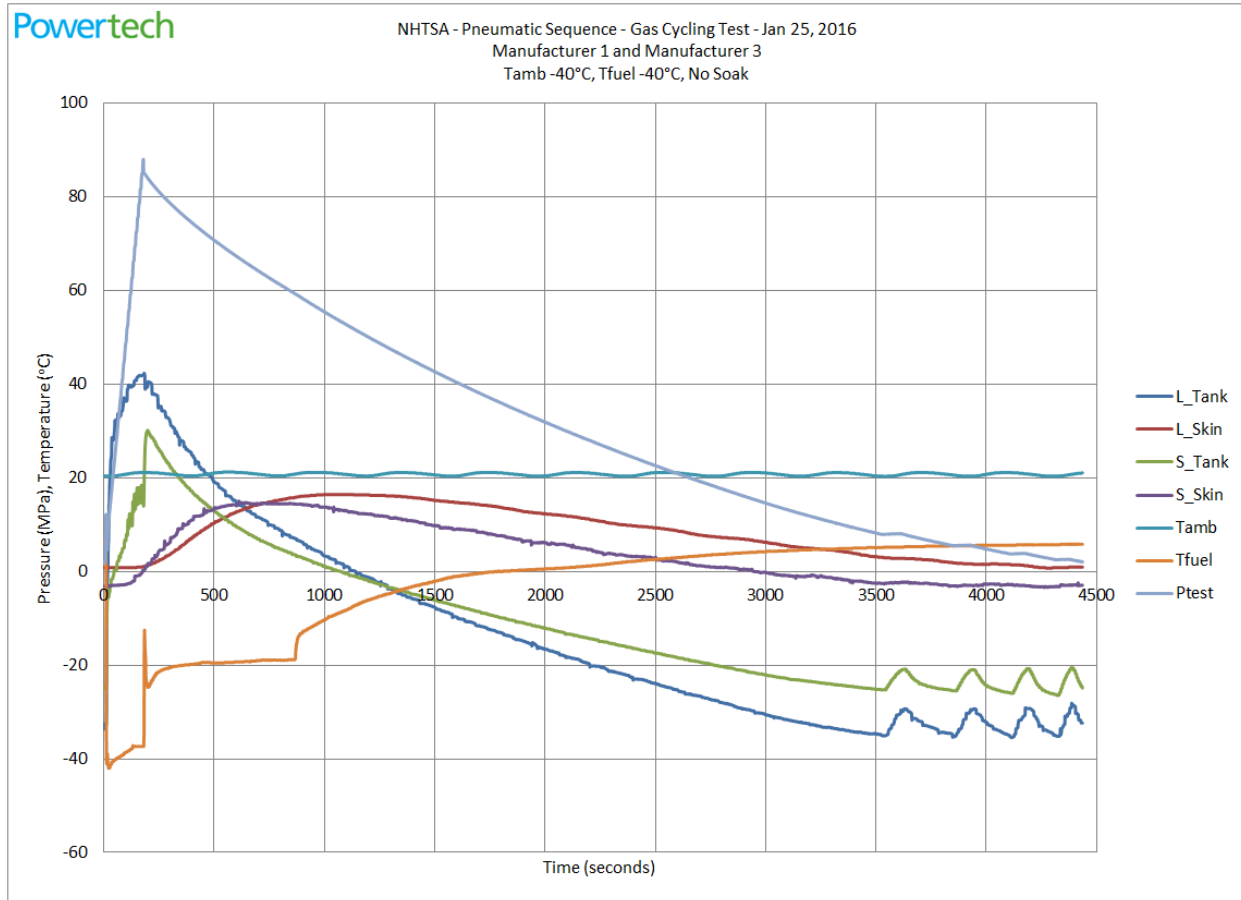

Figure 60. Gas Cycling Test Stage 10 – ambient cycles, full cycle

TEST REPORT

No. TR-00663-01-R2

December 7, 2017

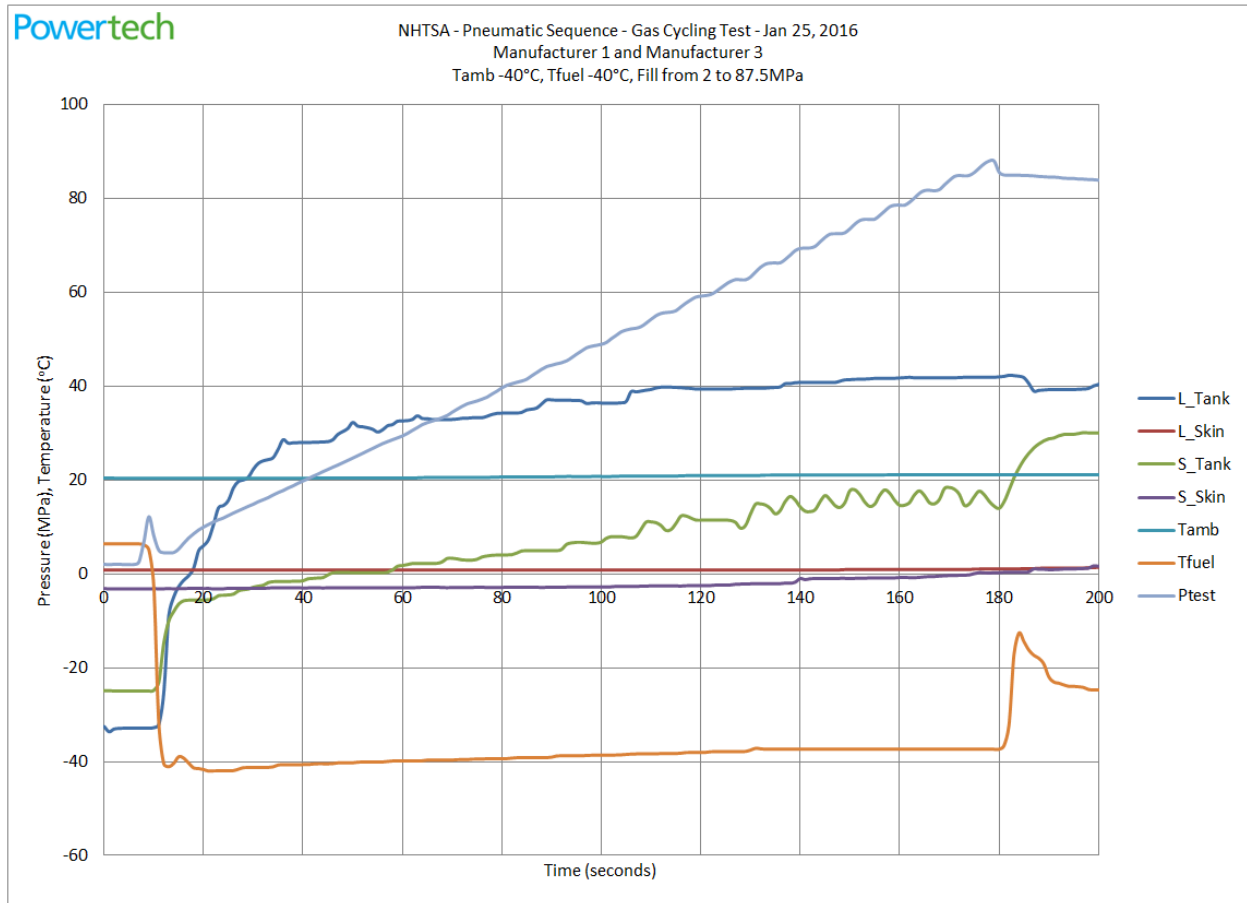

Figure 61. Gas Cycling Test Stage 10 – ambient cycles, fill profile

TEST REPORT

No. TR-00663-01-R2

December 7, 2017

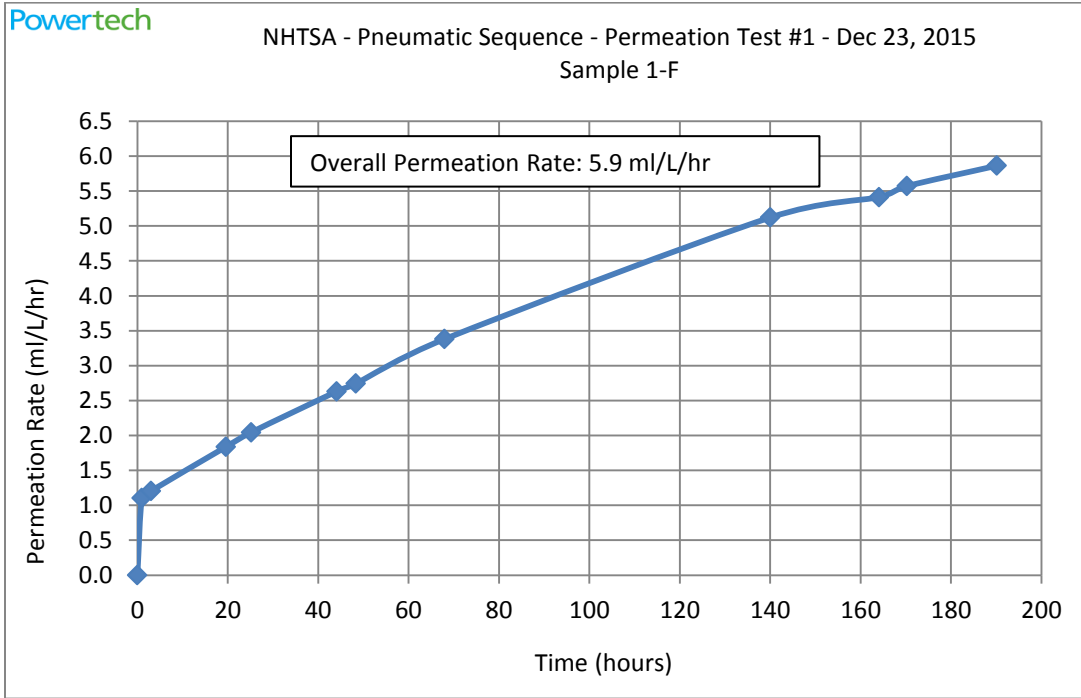

Figure 62. Permeation Test #1 – Container 1-F

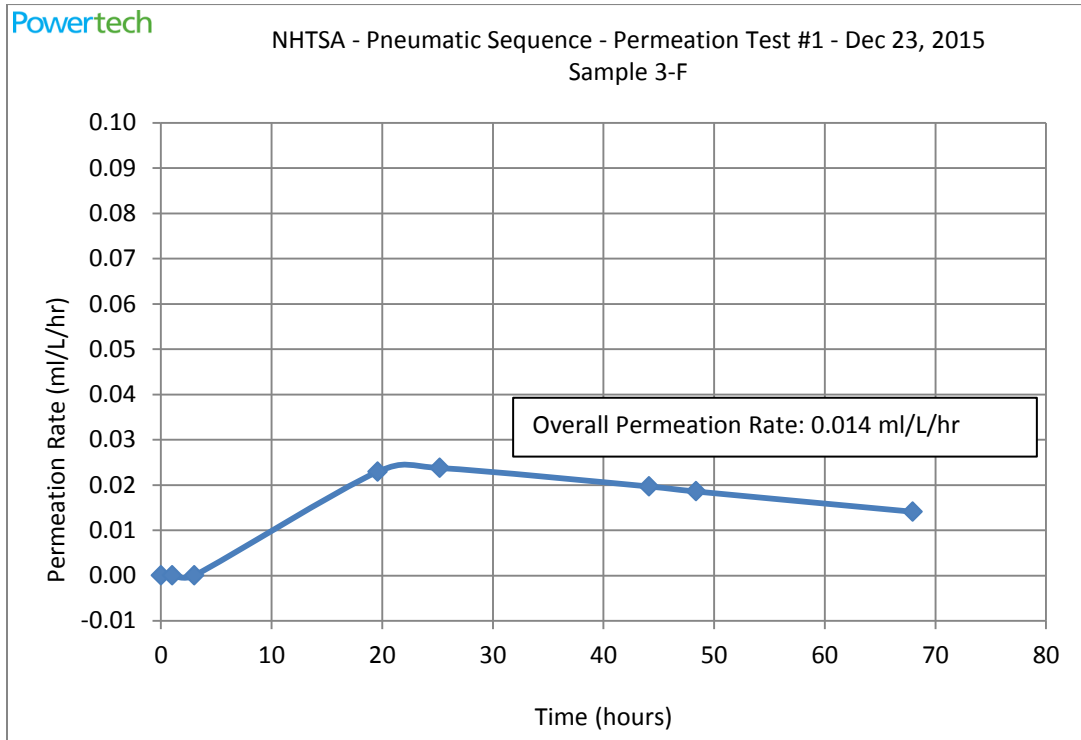

Figure 63. Permeation Test #1, Container 3-F

TEST REPORT

No. TR-00663-01-R2

December 7, 2017

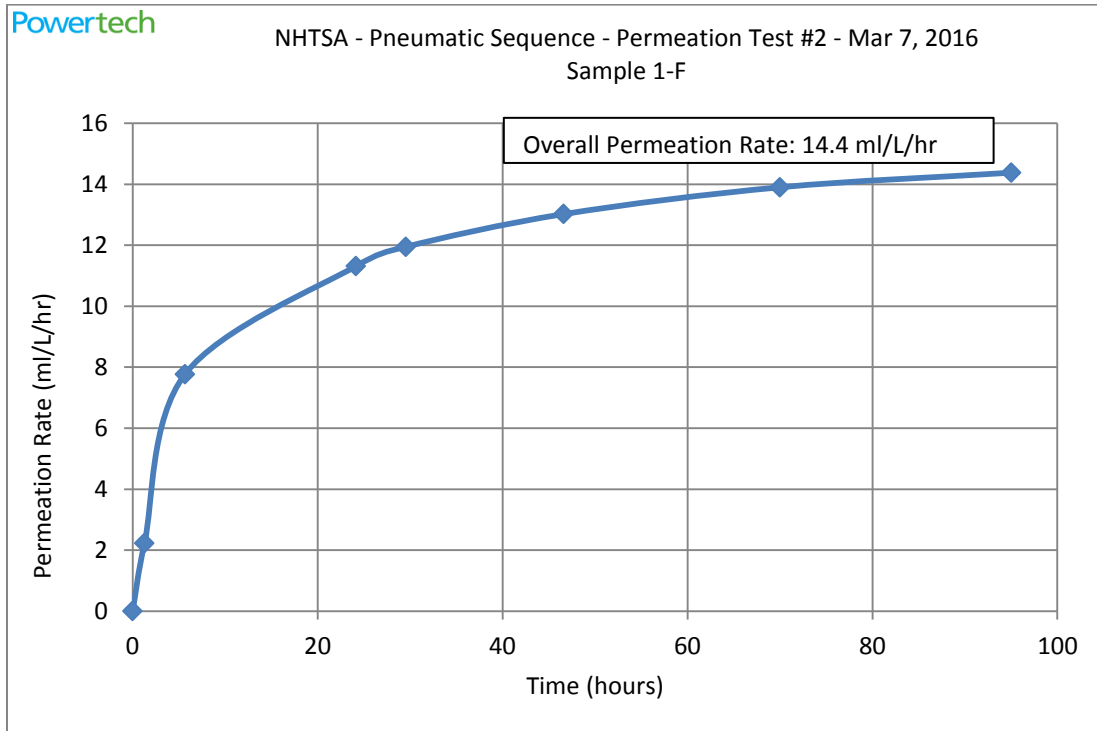

Figure 64. Permeation Test #2, Container 1-F

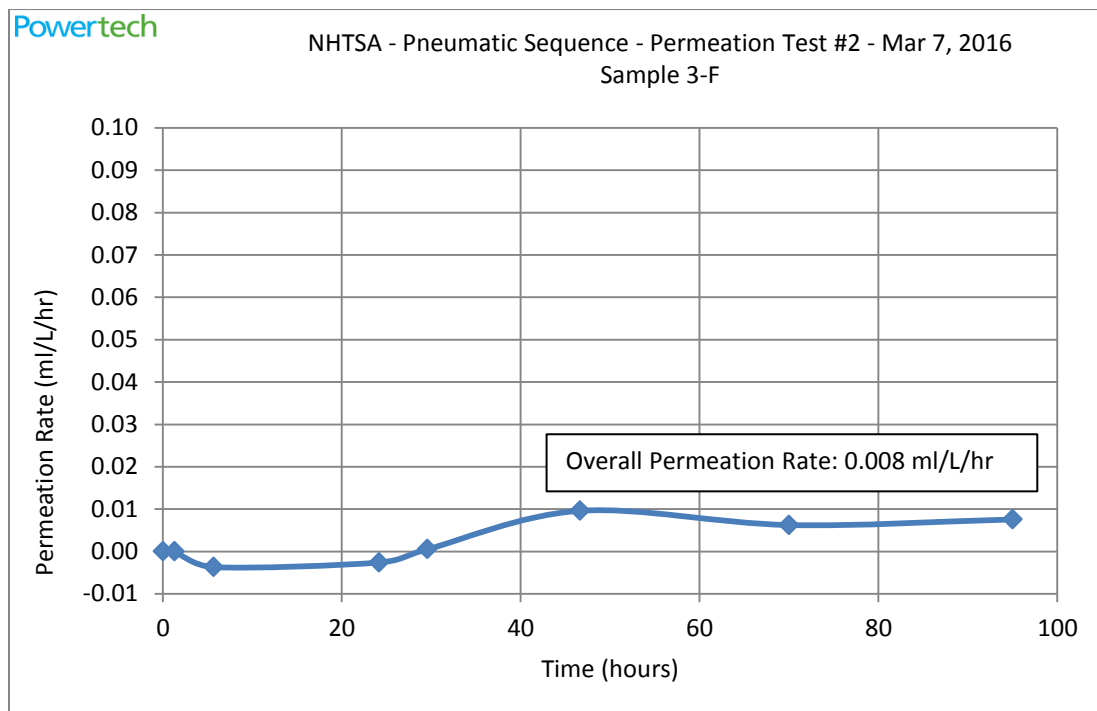

Figure 65. Permeation Test #2, Container 3-F

TEST REPORT

No. TR-00663-01-R2

December 7, 2017

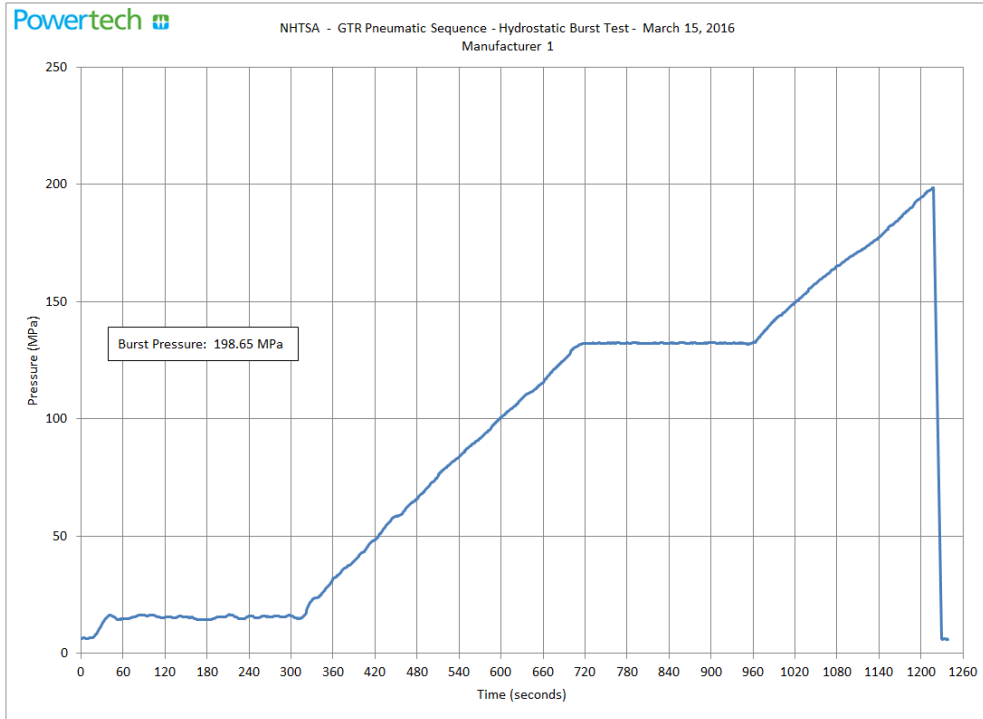

Figure 66. Pneumatic Sequence Burst Test, Container 1-F

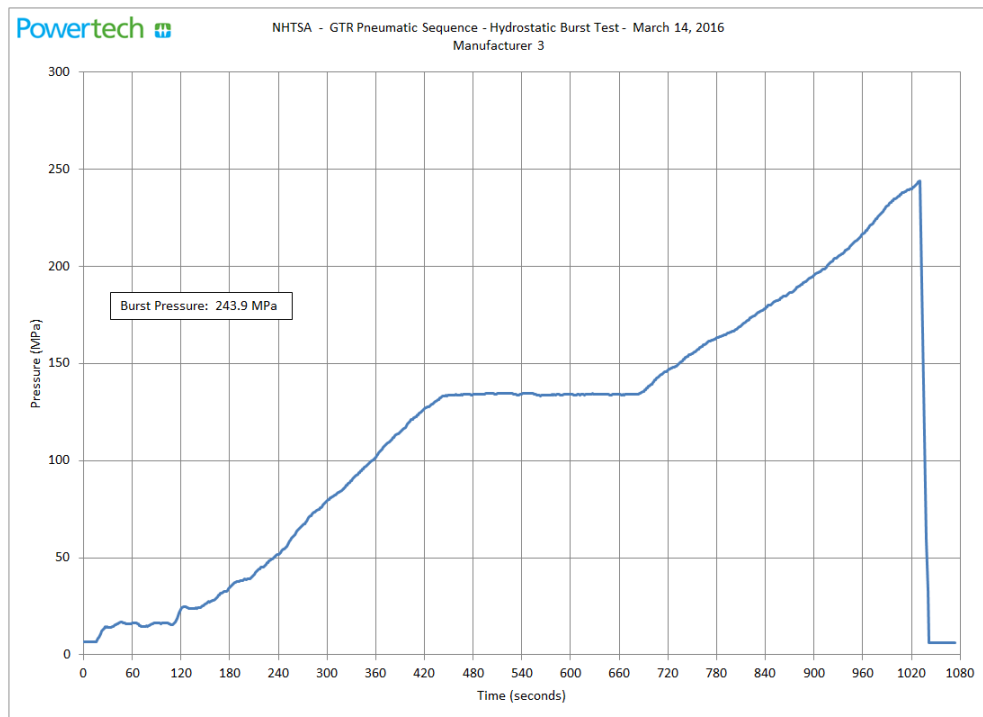

Figure 67. Pneumatic Sequence Burst Test, Container 3-F