

24 September 2002

AGREEMENT

**CONCERNING THE ADOPTION OF UNIFORM TECHNICAL PRESCRIPTIONS
FOR WHEELED VEHICLES, EQUIPMENT AND PARTS WHICH CAN BE FITTED
AND/OR BE USED ON WHEELED VEHICLES AND THE CONDITIONS FOR RECIPROCAL
RECOGNITION OF APPROVALS GRANTED ON THE BASIS OF THESE PRESCRIPTIONS */**

(Revision 2, including the amendments which entered into force on 16 October 1995)

Addendum 21: Regulation No. 22

Revision XX

Incorporating all valid text up to:

05 series of amendments - Date of entry into force: 30 June 2000

Corrigendum 1 to the 05 series of amendments, subject of Depository Notification C.N.427.2000.TREATIES-1 dated 27 June 2000

Corrigendum 2 to the 05 series of amendments, subject of Depository Notification C.N.133.2001.TREATIES-1 dated 13 March 2001

Corrigendum 3 to the 05 series of amendments, subject of Depository Notification C.N.815.2001.TREATIES-2 dated 23 August 2001

Supplement 1 to the 05 series of amendments - Date of entry into force: 20 February 2002 **/

06 series of amendments - Date of entry into force: X X Y Y Z Z Z Z

**UNIFORM PROVISIONS CONCERNING THE APPROVAL OF PROTECTIVE HELMETS AND THEIR
VISORS FOR DRIVERS AND PASSENGERS OF MOTOR CYCLES AND MOPEDS**



UNITED NATIONS

*/ Former title of the Agreement:

Agreement Concerning the Adoption of Uniform Conditions of Approval and Reciprocal Recognition of Approval for Motor Vehicle Equipment and Parts, done at Geneva on 20 March 1958.

**/ For New Zealand, the entry into force is 20 April 2002.

Regulation No. 22

UNIFORM PROVISIONS CONCERNING THE APPROVAL OF PROTECTIVE HELMETS
AND OF THEIR VISORS FOR DRIVERS AND PASSENGERS
OF MOTOR CYCLES AND MOPEDS

CONTENTS

REGULATION	<u>Page</u>
1. Scope	5
2. Definitions	5
3. Application for approval	7
4. Markings	9
5. Approval	9
6. General specifications	12
7. Tests	21
8. Test reports	43
9. Production qualification	43
10. Conformity of production and routine tests	45
11. Modification and extension of approval of a helmet or a visor type	53
12. Penalties for non-conformity of production	54
13. Production definitely discontinued	54
14. Information for wearers	54
15. Transitional provisions	56
16. Names and addresses of technical services responsible for conducting approval tests, and of administrative departments	57

CONTENTS (continued)

ANNEXES

- Annex 1 - Communication concerning approval or extension or refusal or withdrawal of approval or production definitely discontinued of a protective helmet and visor type pursuant to Regulation No. 22
- Annex 2 - Examples of arrangements of approval mark
- Annex 3 - Diagram of protective helmet
- Annex 4 - Headforms
- Annex 5 - Positioning of the helmet on the headform
- Annex 6 - Reference headforms (shape, dimensions)
- ~~Annex 7 - Reference headforms (shape, dimensions below reference plane)~~
- Annex 8 - Test machines
- Annex 9 - Testing of the angle of opening of the visor
- Annex 10 - Abrasion test procedure
- Annex 11 - Methods of measuring light diffusion and light transmission coefficient
- Annex 12 - Type approval scheme (Flow chart)
- Annex 13 - Definitions
- Annex 14 - Product of the spectral distribution of radiation of the signal light and standard illuminant D65
- Annex 15 - Test of refractive powers
- Annex 16 - Test for mist-retardant visors
- Annex 17 - Test for photochromic, liquid crystal visors
- Insert new annex for test equipment
(rotational , visor, WT)

1. SCOPE

This Regulation applies to protective helmets for drivers and passengers of mopeds and of motor cycles with or without side-car 1/ and to the visors fitted to such helmets or intended to be added to them.

2. DEFINITIONS 2/

For the purposes of this Regulation,

- 2.1. "protective helmet" means a helmet primarily intended to protect the wearer's head against impact. Some helmets may provide additional protection;
- 2.2. "shell" means the hard part of the protective helmet, which gives it its general shape;
- 2.3. "protective padding" means a material used to absorb impact energy;
- 2.4. "comfort padding" means a material provided for the wearer's comfort;
- 2.5. "retention system" means the complete assembly by means of which the helmet is maintained in position on the head, including any devices for adjustment of the system or to enhance the wearer's comfort;
- 2.5.1. "chin-strap" means a part of the retention system consisting of a strap that passes under the wearer's jaws to keep the helmet in position;
- 2.5.2. "chin-cup" means an accessory of the chin-strap that fits round the point of the wearer's chin;
- 2.6. "peak" means an extension of the shell above the eyes;
- 2.7. "lower face cover" means a detachable, movable or integral (permanently fixed) part of the helmet covering the lower part of the face;
- 2.7.1. "protective lower face cover" means a detachable, movable or integral (permanently fixed) part of the helmet covering the lower part of the face and intended to protect the chin of the user against impacts;

1/ Protective helmets for wear in competitions may have to comply with stricter provisions.

2/ See also the diagram in annex 3.

- 2.7.2. "non protective lower face cover" means a detachable or movable part of the helmet covering the lower part of the face that does not protect the chin of the user against impacts;
- 2.7.3. "Modular helmet" means a helmet, equipped with a movable or detachable protective lower face cover, that meets the requirements for both conditions of use with or without chin guard in position. Chin protection is only guaranteed with the lower face cover in position.
- 2.8. "visor" means a transparent protective screen extending over the eyes and covering all or part of the face;
- 2.8.1. "sun shield" means an additional tinted screen in combination with transparent protective screen extending that covers the eyes.
- 2.9. "goggles" mean transparent protectors that enclose the eyes;
- 2.10. Disposable protective film
- 2.10.1. A removable plastic film may be applied to protect the visor prior to use. In this case the film has to be opaque or printed, so that it must be removed before use.
- 2.10.2. A protective film (tear-off) may be used for racing for example to reduce the level of luminous transmission. Such tear-off-films are not for use on the road and are not covered by this Regulation.
- 2.11. "ocular areas" mean two circles of minimum diameter 52 mm spaced symmetrically about the vertical centre line of the visor, the distance between the centres of the circles being 64 mm measured in the horizontal front plane of the visor as worn.
- 2.12. "luminous transmittance τ_v " is defined in annex 13.
- 2.13. "relative visual attenuation quotient" means the relative visual quotient (Q) and is defined in annex 13.
- 2.14. "basic plane of the human head" means a plane at the level of the opening of the external auditory meatus (external ear opening) and the lower edge of the orbits (lower edge of the eye sockets);
- 2.15. "basic plane of the headform" means a plane which corresponds to the basic plane of the human head;
- 2.16. "reference plane" means a construction plane parallel to the basic plane of the headform at a distance from it which is a function of the size of the headform;
- 2.17. "protective helmet type" a class of protective helmets displaying no substantial differences from one another, with special regard to:
- 2.17.1. ~~manufacturer's~~ "trade mark"
However, it is possible to have different trade marks, provided that the manufacturer's name is also present in an easily accessible position.

- 2.17.2. shell or protective padding materials. However, a protective helmet type may include a range of sizes, provided that the thickness and density of the protective padding of each element in the range is at least equal to that of the protective helmet that has passed the tests.
- A type of helmet may include different shell sizes (provided that the shell design must stay the same) and different retaining systems provided that they all meet the requirements of these Regulation
- 2.18. "visor type" means a category of visors which do not differ substantially in such essential characteristics as:
- 2.18.1. the trade name or mark, or
- 2.18.2. the materials, dimensions, manufacturing processes (such as extrusion or moulding), colour, surface treatment, system of attachment to the helmet;
- 2.19. "approval test" means a test to determine the extent to which a protective helmet type and/or a visor type submitted for approval is capable of satisfying the requirements;
- 2.20. "production quality test" means a test to determine whether the manufacturer is able to produce helmets and/or visors in conforming with the helmets and/or visors submitted for type approval;
- 2.21. "routine testing" means the testing of a number of helmets and/or visors selected from a single batch to verify the extent to which they satisfy the requirements.
- 2.22. "accessory" means any object intended to integrate the secondary functionalities of the helmet (eg. tear off inner visor, electronic devices and their support)
3. APPLICATION FOR APPROVAL
- 3.1. Application for approval of a protective helmet type
- 3.1.1. The application for approval of a protective helmet type, without or with one or more visor types, shall be submitted by the helmet manufacturer or by the holder of the manufacturer's name or trade mark or by his duly accredited representative, and for each type the application shall be accompanied by the following:
- 3.1.1.1. Drawings in scale with sufficient detail to permit identification of the helmet type, including the methods of assembly. The drawings shall show the position intended for the approval mark as set out in paragraph 5.1.4.1.,
- 3.1.1.2. A brief technical specification stating the materials used and a test report of the photometric and colorimetric performance of the retroreflective material.
- 3.1.1.3. If the helmet is fitted with one or more visors:

- 3.1.1.3.1. Drawings in scale with sufficient detail to permit identification of the visor type and of its means of attachment to the helmet. The drawings shall show the position intended for the approval mark as set out in paragraph 5.1.4.1.,
- 3.1.1.3.2. A technical description of the visor stating the materials used, the manufacturing processes and, where appropriate, the surface treatment,
- 3.1.1.4. A number of helmets, with or without visors, out of [20] samples of different sizes, sufficient to enable all the tests specified in paragraph 7.1. to be conducted and one helmet additionally to be retained by the technical service responsible for conducting the approval test.
- 3.1.1.5. For each visor type, if any, 7 (+3 if optional test for mist retardant visor is carried out) visors taken from a sample of not less than 14 (+ 6 if optional test) specimens. 6 (+ 3 if optional test) visors shall be subjected to the tests and the seventh (or tenth if optional test) shall be retained by the technical service responsible for conducting the approval test.
- 3.2. Application for approval of a visor type
 - 3.2.1. The application for approval of a visor type shall be submitted by the visor manufacturer or by the holder of the manufacturer's name or trade mark or by his duly accredited representative, and for each type the application shall be accompanied by the following:
 - 3.2.1.1. Drawings in scale with sufficient detail to permit identification of the visor type and of its means of attachment to the helmet. The drawings shall show the position intended for the approval mark as set out in paragraph 5.2.4.1.,
 - 3.2.1.2. A technical description of the visor stating materials used, the manufacturing processes and, where appropriate, the surface treatment,
 - 3.2.1.3. List of approved helmet types to which the visor may be fitted,
 - 3.2.1.4. For each visor type, if any, 7 (+3 if optional test for mist retardant visor is carried out) visors taken from a sample of not less than 14 (+ 6 if optional test) specimens and the helmets to which the visors are intended to be fitted. 6 (+ 3 if optional test) visors shall be subjected to the tests and the seventh (or tenth if optional test) shall be retained by the technical service responsible for conducting the approval test.
- 3.3. The competent authority shall verify the existence of satisfactory arrangements in order to ensure effective control of the conformity of production in accordance with the provisions of paragraph 10. and annex 12 before type approval is granted.

4. MARKINGS
- 4.1. The protective helmets submitted for approval in conformity with paragraph 3.1. above shall bear:
- 4.1.1. On the helmet, the applicant's trade name or mark and an indication of the size (In letter and cm) and, if appropriate, an indication of the unsuitability of the lower face cover to offer any protection against impacts to the chin.
- 4.1.2. On the visor, the applicant's trade name or mark and, if appropriate, an indication of the unsuitability of the visor for use during the hours of darkness or in conditions of poor visibility.
- 4.2. The visors submitted for approval in conformity with paragraph 3.2. above shall bear the applicant's trade name or mark and, if appropriate, an indication of the unsuitability of the visor for use during the hours of darkness or in conditions of poor visibility.
- 4.3. The marking shall not be placed within the main visibility area.
- 4.4. The marking shall be indelible, clearly legible and in readily accessible place.
5. APPROVAL
- 5.1. Approval of a protective helmet type, without or with one or more visor types
- 5.1.1. If the protective helmets and the visors, if any, submitted in pursuance of paragraph 3.1.1.4. above meet the requirements of this Regulation, approval shall be granted.
- 5.1.2. An approval number shall be assigned to each type approved. Its first two digits (at present 06) shall indicate the series of amendments incorporating the most recent major technical amendments made to the Regulation at the time of issue of the approval. The same Contracting Party shall not assign the same number to another helmet type covered by this Regulation.
- 5.1.3. Notice of approval or of extension or refusal or withdrawal of approval or production definitely discontinued of a protective helmet type, without or with one or more visor types pursuant to this Regulation shall be communicated to the Parties to the 1958 Agreement applying this Regulation, by means of a form conforming to the model in annex 1 A to this Regulation.
- 5.1.4. In addition to the marks described in paragraph 4.1.1. above, the following particulars shall be indicated on every protective helmet conforming to a type approved under this Regulation by means of the labels referred to in paragraph 5.1.9. below:
- 5.1.4.1. An international approval mark consisting of:

5.1.4.1.1. A circle surrounding the letter "E" followed by the distinguishing number of the country which has granted approval, 3/

5.1.4.1.2. The approval number followed by:

5.1.4.1.2.1. a slash and symbol:

"J" if the helmet does not have a lower face cover
"P" if the helmet has a protective lower face cover,
"NP" if the helmet has a non protective lower face cover

It is possible a combination of two level of protection,
as example

"P/J" if the helmet has a detachable or movable protective
lower face cover

Note: In this case could be possible insert and indication
if the protective lower face cover could be detachable or
movable like "d" or "m".

5.1.4.1.2.2. a dash followed by a production serial number. The production serial numbers shall be continuous for all protective helmets of the same type approved, and each authority shall keep a register from which it can check that the type and production serial numbers correspond.

3/ 1 for Germany, 2 for France, 3 for Italy, 4 for the Netherlands, 5 for Sweden, 6 for Belgium, 7 for Hungary, 8 for the Czech Republic, 9 for Spain, 10 for Yugoslavia, 11 for the United Kingdom, 12 for Austria, 13 for Luxembourg, 14 for Switzerland, 16 for Norway, 17 for Finland, 18 for Denmark, 19 for Romania, 20 for Poland, 21 for Portugal, 22 for the Russian Federation, 23 for Greece, 24 for Ireland, 25 for Croatia, 26 for Slovenia, 27 for Slovakia, 28 for Belarus, 29 for Estonia, 30 for Republic of Moldova, 31 for Bosnia and Herzegovina, 32 for Latvia, 34 for Bulgaria, 36 for Lithuania, 37 for Turkey, 39 for Azerbaijan, 40 for The former Yugoslav Republic of Macedonia, 42 for the European Community (Approvals are granted by its Member States using their respective ECE symbol), 45 for Australia, 46 for Ukraine, 47 for South Africa and 48 for New Zealand, 49 for Cyprus, 50 for Malta, 52 for Malaysia, 54 for Albania, 56 for Montenegro, 57 for San Marino, 60 for Georgia, 62 for Egypt.

Subsequent numbers shall be assigned to other countries in the chronological order in which they ratify or accede to the Agreement Concerning the Adoption of Uniform Technical Prescriptions for Wheeled Vehicles, Equipment and Parts which can be Fitted and/or be Used on Wheeled Vehicles and the Conditions for Reciprocal Recognition of Approvals Granted on the Basis of these Prescriptions, and the numbers thus assigned shall be communicated by the Secretary-General of the United Nations to the Contracting Parties to the Agreement.

- 5.1.4.1.3. The marking and/or symbol denoting the unsuitability of the lower face cover, if appropriate.
- 5.1.4.1.4. The marking on the helmet and, if appropriate, lower face cover shall be clearly legible, indelible and resistant to wear.
- 5.1.4.1.5. The label can include also, not in alternative, a bar or QR code for digital reading.
- 5.1.5. In addition to the marks described in paragraph 4.1.2. above, the following particulars shall be affixed visibly and in a readily accessible place to every visor, if any, conforming to a type approved with a helmet under this Regulation:
- 5.1.5.1. An international approval mark consisting of:
- 5.1.5.1.1. A circle surrounding the letter "E" followed by the distinguishing number of the country which has granted approval, 3/
- 5.1.5.1.2. A reference alphanumerical number.
- 5.1.5.1.3. The symbol denoting daytime use only, if appropriate.
- 5.1.6. The marking on the visor shall be clearly legible, indelible and resistant to wear.
- 5.1.7. The marking on the visor shall not be placed within the main visibility area.
- 5.1.8. The approval marks prescribed in paragraphs 5.1.4., 5.1.5. and 5.2.4. above may not be replaced by an Unique Identifier (UI) as referred to in Schedule 5 of the 1958 Agreement."
- 5.1.9. Annex 2 A to this Regulation gives examples of the arrangements of the approval marks for protective helmets and visors.
- 5.1.10. In order to be considered as approved under this Regulation, subject to the provisions of paragraph 9. below, every protective helmet shall bear, sewn to its retention system, one of the labels referred to in paragraph 5.1.4. above. A different method of securing the label is authorized if it complies with the above provisions.
- 5.1.11. The labels referred to in paragraph 5.1.9. above may be issued either by the authority which has granted the approval or, subject to that authority's authorization, by the manufacturer.
- 5.1.12. The label referred to in paragraph 5.1.9. above shall be clearly legible and resistant to wear.
- 5.1.13. Approval of helmets of size 48/49 shall be granted without additional tests if such helmets belong to a type already approved which comprises size 50 in its range of sizes.
- 5.1.14. Approval of helmets larger than size 62 shall be granted without additional tests if such helmets belong to a type already approved which comprises size 62 in its range of sizes.

- 5.2. Approval of a visor type
- 5.2.1. Where the visors submitted in accordance with paragraph 3.2.1.4. above meet the requirements of paragraphs 6.15. and 7.8. of this Regulation, approval shall be granted.
- 5.2.2. An approval number shall be assigned to each type approved. Its first two digits (at present 06) shall indicate the series of amendments incorporating the most recent major technical amendments made to the Regulation at the time of issue of the approval.
The same Contracting Party shall not assign the same number to another visor type covered by this Regulation.
- 5.2.3. Notice of approval or of extension or refusal or withdrawal of approval or production definitely discontinued of a visor type pursuant to this Regulation shall be communicated to the Parties to the 1958 Agreement applying this Regulation, by means of a form conforming to the model in annex 1 B to this Regulation.
- 5.2.4. In addition to the marks prescribed in paragraph 4.2. above, the following particulars shall be affixed visibly and in a readily accessible place to every visor conforming to a type approved under this Regulation:
- 5.2.4.1. An international approval mark consisting of:
- 5.2.4.1.1. the approval symbol described in paragraph 5.1.4.1.1.,
- 5.2.4.1.2. the approval number,
- 5.2.4.1.3. a production serial number. The production serial numbers shall be continuous for all visors of the same type approved, and each authority shall keep a register from which it can check that the type and production serial numbers correspond.
- 5.2.4.1.4. the symbol denoting daytime use only, if appropriate.
- 5.2.5. The approval mark shall be clearly legible, indelible and resistant to wear.
- 5.2.6. The marking shall not be placed within the main visibility area.
- 5.2.7. Annex 2 B to this Regulation gives an example of the arrangement of approval mark for a visor.
6. GENERAL SPECIFICATIONS
- 6.1. The basic construction of the helmet shall be in the form of a hard outer shell, containing additional means of absorbing impact energy, and a retention system.
- 6.2. The protective helmet may be fitted with ear flaps and a neck curtain.
- 6.2.1. It may also have a detachable peak, a visor and an additional sun shield and, if is the case, electronic equipment or accessories.

- 6.2.2. It may also have a **fixed, detachable or movable** lower face cover. If fitted with a **not protective** lower face cover the outer surface of the cover shall be marked "Does not protect chin from impacts" and/or with the symbol shown in figure 1 below indicating the unsuitability of the lower face cover to offer any protection against impacts to the chin.



Figure 1: Symbol "Does not protect chin from impacts"

Note: this symbol or indication must be visible and extend over at least [2] cm²

- 6.3. No component or device may be fitted to or incorporated in the protective helmet unless it is designed in such a way that it will not cause injury and that, when it is fitted to or incorporated in the protective helmet, the helmet still complies with the requirements of this Regulation.
- 6.4. The extent of the protection provided shall be as follows:
- 6.4.1. The shell shall cover all areas above plane AA' and shall extend downwards at least as far as the lines CDEF on both sides of the headform (see annex 4, fig. 1 A).
- 6.4.2. At the rear, the rigid parts and, in particular, the shell shall not be within a cylinder defined as follows (see annex 4, fig. 1 B):
- (i) Diameter 100 mm;
 - (ii) Axis, situated at the intersection of the medium plane of symmetry of the headform and of a plane parallel to and 110 mm below the reference plane.
- 6.4.3. The protective padding shall cover all the areas defined in paragraph 6.4.1., account being taken of the requirements of paragraph 6.5.
- 6.5. The helmet shall not dangerously affect the wearer's ability to hear. The temperature in the space between the head and the shell shall not rise inordinately; to prevent this, ventilation holes may be provided in the shell.

Where means for attaching a visor are not provided, the profile at the front edge shall not prevent the wearing of goggles.

- 6.6. All projections from or irregularities in the outer surface of the shell greater than 2 mm shall be tested for shear assessment according to paragraphs 7.4.1. or 7.4.2. The outer surface of the helmet shall be tested for friction assessment according to paragraphs 7.4.1. or 7.4.2. **This applies in particular to a movable lower face cover in all positions intended by the manufacturer.**
- 6.7. All external projections shall be radiused and any external projections other than press-fasteners shall be smooth and adequately faired.
- 6.7.1. All external projections not more than 2 mm above the outer surface of the shell (e.g. rivet heads) shall have a radius of a minimum of 1 mm.
- 6.7.2. All external projections more than 2 mm above the outer surface of the shell shall have a radius of a minimum of 2 mm.
- The latter specific requirements shall not apply if a projection satisfies the requirements in paragraphs 7.4.1. or 7.4.2. below.
- 6.8. There shall be no inward-facing sharp edges on the inside of the helmet; rigid, projecting internal parts shall be covered with padding so that any stresses transmitted to the head are not highly concentrated.
- 6.9. The various components of the protective helmet, shall be so assembled that they are not liable to become easily detached as a result of an impact.
- In the case of visor and movable or detachable lower face cover, only when in not protective position, the detachment is acceptable provided that it is complete and not to cause possible injuries to the user.**
- 6.10. Retention systems shall be protected from abrasion.
- 6.11. The helmet shall be held in place on the wearer's head by means of a retention system which is secured under the lower jaw. All parts of the retention system shall be permanently attached to the system or to the helmet.
- 6.11.1. If the retention system includes a chin-strap, the strap shall be not less than 20 mm wide under a load of 150 N \pm 5 N applied under the condition prescribed in paragraph 7.6.2.
- 6.11.2. The chin strap shall not include a chin-cup.
- 6.11.3. Chin straps shall be fitted with a device to adjust and maintain tension in the strap.
- 6.11.4. Chin strap fastening and tensioning devices shall be positioned on the straps either so that there are no rigid parts extending more than 130 mm vertically below the headform reference plane with the helmet mounted on the appropriate sized headform, or so that the whole of the device is between the bony projections of the underside of the lower jaw.

- 6.11.5. Retaining systems using closing rings ("double D") or a "roller buckle" shall be conceived to prevent the total opening of the system and to maintain the strap in the desired position once the retaining system has been adjusted.
If the retaining system can be opened completely, must be possible only with voluntary action. To prevent any possible misuse the helmet must be provided with detailed instructions on the use of the buckle.
- 6.11.6. Sliding bar and double-D ring fastening devices shall be fitted with a pulling flap to be used for releasing the retention system. Its colour must be red and its minimum dimensions must be 10 x 20 mm.
- 6.11.7. If a retention system includes a quick-release mechanism, then the method of release of this mechanism shall be self-evident. Any levers, tabs, buttons or other components which need to be operated to release the mechanism shall be coloured red, those parts of the rest of the system which are visible when closed shall not be similarly coloured, and the mode of operation shall be permanently indicated.
- 6.11.8. The retention system shall remain closed when the tests described in paragraphs 7.3., 7.6. and 7.7. are carried out.
- 6.11.9. The buckle of the retention system shall be designed so as to preclude any possibility of incorrect manipulation. This means, inter alia, that it must not be possible for the buckle to be left in a partially closed position.
- 6.12. If the lower face cover is detachable or movable, the lower face cover shall be fitted with a device that maintain into the intended position. The device must be such that incorrect handling is impossible. The control/actuating device must be of red color. The helmet has to comply with the requirements for helmet categories "J", "P" or both.
- 6.13. The characteristics of the materials used in the manufacture of helmets shall be known not to undergo appreciable alteration under the influence of ageing, or of the circumstances of use to which the helmet is normally subjected, such as exposure to sun, extremes of temperature and rain. For those parts of the helmet coming into contact with the skin, the materials used shall be known not to undergo appreciable alteration through the effect of perspiration or of toilet preparations. The manufacturer shall not use materials known to cause skin troubles. The suitability of a proposed new material shall be established by the manufacturer.
- 6.14. After the performance of one of the prescribed tests, the protective helmet shall not exhibit any breakage or deformation dangerous to the wearer.
- Note: As example visor sunshield and Shell cracks more than [4cm] from tip to border or any part partially detached (spoiler, lower face cover, accessories) that can hurt the user while he's rolling on the road.

6.15. Peripheral vision

- 6.15.1. To carry out the test, the technical service shall select from among the existing sizes of a helmet type the size it considers likely to yield the least favourable result;
- 6.15.2. The helmet shall be placed on the headform corresponding to its size by the procedure set out in annex 5 to this Regulation;
- 6.15.3. In the above conditions there shall be no occultation in the field of vision bounded by: (see annex 4, figs. 2A,2B,2C and 2D)
- 6.15.3.1. horizontally: two segments of dihedral angles symmetrical in relation to the median longitudinal vertical plane of the headform and situated between the reference and the basic planes.
Each of these dihedral angles is defined by the median longitudinal vertical plane of the headform and the vertical plane forming an angle of not less than 105° with the median longitudinal vertical plane and whose edge is the straight line LK;
- 6.15.3.2. upwards: a dihedral angle defined by the reference plane of the headform and a plane forming an angle of not less than 7° with the reference plane and whose edge is the straight line L₁ L₂, the points L₁ and L₂ representing the eyes;
- 6.15.3.3. downwards: a dihedral angle defined by the basic plane of the headform and a plane forming an angle of not less than 45° with the basic plane and whose edge is the straight line K₁ K₂.
However, this downward clearance makes specific allowance for breath deflectors.
The breath deflector allowance is shown in [Annex 4 fig. 2D]. It includes the region that is within 31 mm to the right and left of the longitudinal plane and that lies below the two planes that form 45° angles with the longitudinal plane and that intersect it at the level of the [6 mm below the basic] plane.
- 6.16. Visors
- 6.16.1. The systems of attachment of a visor to a helmet shall be such that the visor is removable. It must be possible to manoeuvre the visor out of the field of vision with a simple movement of one hand. However, the latter prescription may not be required for helmets which do not provide chin protection provided that a label is attached to the helmet to the effect of warning the purchaser that the visor cannot be manoeuvred.
- 6.16.2. Angle opening (see annex 9)
- 6.16.3. Field of vision

- 6.16.3.1. The visor shall not comprise any part liable to impair the user's peripheral vision as defined in paragraph 6.14. when the visor is in the totally opened position. Furthermore, the lower edge of the visor shall not be situated in the downward field of vision of the user as defined in paragraph 6.14. when the visor is in closed position. The surface of the visor in the peripheral field of vision of the helmet may however include:
- (i) The lower edge of the visor, provided that it is made of a material with at least the same transmittance as the rest of the visor,
 - (ii) A device to allow the visor to be manoeuvred or locked in close position. However, if this device is situated within the field of vision of the visor defined in paragraph 6.16.3.2. below it shall be at the lower edge and present a maximum height (h) of 10 mm and its width (l) shall be such that the product (h x l) at the most is equal to [1.5 cm²], if bigger it must be made of a material with at least the same transmittance as the visor and it must be free of any engraving, paint or other covering feature,
 - (iii) Fixings and devices to allow the visor to be manoeuvred if they are situated outside of the field of vision of the visor and if the total surface of these parts, including devices, if any, to allow the visor to be manoeuvred does not exceed 2 cm², possibly distributed on each side of the field of vision.
- 6.16.3.2. The field of vision of the visor is defined by:
- (a) A dihedron defined by the reference plane of the headform and a plane forming an angle of at least 7° upwards, its edge being the straight line L₁ L₂, with points L₁ and L₂ representing the eyes,
 - (b) Two segments of dihedral angles symmetrical to the median vertical longitudinal plane of the headform. Each of these dihedral angles is defined by the median vertical longitudinal plane of the headform and the vertical plane forming with this plane an angle of 90°, its edge being the straight line LK,
 - (c) and the lower edge of the visor.
- 6.16.3.3. To determine the field of vision as defined in paragraph 6.15.3.2. above, the helmet fitted with the visor being tested shall be placed on a test headform of suitable size in accordance with the provisions of paragraph 7.3.1.3.1., with the helmet tipped towards the rear as specified in paragraph 7.3.1.3.1. and the visor placed in the closed position.
- 6.16.3.4. Visors shall have a luminous transmittance $\tau_v \geq 80\%$, relative to the standard illuminant D65. A luminous transmittance $80\% > \tau_v \geq [35]\%$, measured by the method given in paragraph 7.8.3.2.1.1., is also permissible if the visor is marked with the symbol shown in figure 2 and/or with the English words "DAYTIME USE ONLY".

When describing the transmittance properties of photochromic, liquid crystal or equivalent visors, two values as to be considered: one corresponds to the fade state, the other to the darkened state. The visor shall be classified according to the darkened state. The luminous transmittance shall be measured before the abrasion test.

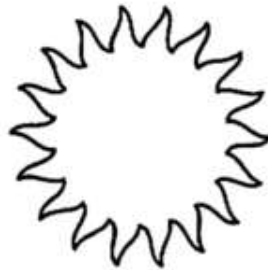

Figure 2: Symbol "Daytime use only"

Note: this symbol or indication must be visible and extend over at least [1] cm²

- 6.16.3.5. Visors shall be free from any significant defects likely to impair the vision, such as bubbles, scratches, inclusions, dull spots, holes, mould marks, scratches or other defects originating from the manufacturing process in the field of vision. The light diffusion shall not exceed the limit in accordance with paragraph 7.8.3.2.1.2. when measured in accordance with one of the methods specified in annex 11.

If different results arise when this is assessed, the requirements on scattered light shall be measured and assessed over an area 5 mm in diameter which includes the presumed error. In addition, the regular transmittance shall not deviate by more than " 5 per cent from the reference value, measured in one of two sight points specified in paragraph 6.15.3.8., at any point within the field of vision of the visor.

- 6.16.3.6. Visors shall in addition be sufficiently transparent, shall not cause any noticeable distortion of object as seen through the visor, shall be resistant to abrasion, resistant to impact and shall not give rise to any confusion between the colour used in road traffic sign and signals. The relative visual attenuation quotient (Q) shall not be less than:

0.80 for red signal light;
0.60 for yellow signal lights;
0.60 for green signal light;
0.60 for blue signal light.

The relative attenuation quotient shall be measured by the method given in paragraph 7.8.3.2.1.1., before the abrasion test.

Note: When calculating the value of Q from the spectral measurements, the value in annex 14 shall be used. Linear interpolation of these values for steps smaller than 10 nm is permissible.

6.16.3.7. In the range 500 nm to 650 nm, the spectral transmittance, measured by the method given in paragraph 7.8.3.2.1.1., of the visor shall not be less than 0.2 τ_v . The spectral transmittance shall be measured before the abrasion test.

6.16.3.8. The table contains the permissible refractive powers at the sight points. The sight points are located in the reference plane 32 mm to the right and the left of the longitudinal median plane (see fig. 2B).

Permissible refractive power values for visors

Spherical effect	Astigmatic effect	Prismatic effect difference		
		Horizontal		Vertical
$\frac{D_1 + D_2}{2}$	$ D_1 - D_2 $	Base Out	Base In	
m^{-1}	m^{-1}	cm/m	cm/m	cm/m
± 0.12	0.12	1.00	0.25	0.25

D_1, D_2 : Refractive effect in two main sectors

The requirements for the prismatic effect apply to the difference between the values at the two sight points.

The refractive powers shall be measured according to method specified in annex 15.

6.16.3.9. Mist retardant visor (Optional requirements)

The internal face of the visor is regarded as having a mist retardant facility if the square of the specular transmittance has not fallen below 80 per cent of the initial value without misting within 20 s when tested as described in annex 16. Such facility may be indicated by the English words "MIST RETARDANT".

6.17. Sun shield

6.17.1. Sun shield shall not restrain or prevent the movement of the visor. On opening the visor, the sun shield can pivot in the working position.

6.17.1.1. By means of a simple movement the sun shield shall be able to be moved separately from the visor out of the visual field.

6.17.2. Field of vision

6.17.2.1. Sun shield shall not restrict the field of vision given in paragraph 6.15 in the working or parking position. If the sun shield is fixed outside of the visor, the surface may include fixings or devices to make movement possible. The total surface of the fixings or devices shall not exceed 2cm²; they can be distributed on both sides of the field of vision.

- 6.17.2.2. Sun shield shall have a luminous transmittance τ_v [$>20\%$], relative to the standard illuminant D65.
- 6.17.2.3. Sun shield shall be free from any significant defects likely to impair the vision, such as bubbles, scratches, inclusions, dull spots, holes, mould marks, scratches or other defects originating from the manufacturing process in the field of vision.
- 6.17.2.4. Sun shield shall not cause any noticeable distortion of object as seen through the visor, resistant to impact and shall not give rise to any confusion between the colour used in road traffic sign and signals. The relative visual attenuation quotient (Q) shall not be less than:
- [0.80] for red signal light;
 [0.60] for yellow signal lights;
 [0.60] for green signal light;
 [0.60] for blue signal light.
- The relative attenuation quotient shall be measured by the method given in paragraph 7.8.3.2.1.1.
- 6.17.2.5. [In the range 475 nm to 650 nm, the spectral transmittance, measured by the method given in paragraph 7.8.3.2.1.1., of the visor shall not be less than 0.2 τ_v
- 6.17.2.6. The table contains the permissible refractive powers at the sight points. The sight points are located in the reference plane 32 mm to the right and the left of the longitudinal median plane (see fig. 2B).

Permissible refractive power values for sun shields; determined in combination with visor.

Spherical effect	Astigmatic effect	Prismatic effect difference		
		Horizontal		Vertical
$\frac{D_1 + D_2}{2}$	$ D_1 - D_2 $	Base Out	Base In	
m^{-1}	m^{-1}	cm/m	cm/m	cm/m
± 0.12	0.12	1.00	0.25	0.25

D_1, D_2 : Refractive effect in two main sectors

The requirements for the prismatic effect apply to the difference between the values at the two sight points.

The refractive powers shall be measured according to method specified in annex 15.

6.18. Conspicuity marking

6.18.1. General

In order to comply with national requirements for use, the helmet may be required by individual Contracting Parties to contribute to the conspicuity of the user both during the daytime and at night:

from the front;
from the rear;
from the right;
from the left

by means of parts made of reflective materials which conform to the specifications laid down in paragraphs 6.16.2. to 6.16.6. of this Regulation.

It is allowed that the helmet is equipped with reflective materials on the box, with proper indications to the user on where and how to apply them on the helmet without damage.

Note: The mandating of conspicuity marks is left to the discretion of individual Contracting Parties. Article 3 of the Agreement to which this Regulation is annexed shall not prevent the Contracting Parties from prohibiting the use of helmets not meeting the conspicuity requirements.

6.18.2. Reflective parts

6.18.2.1. Geometry

The total surface area and shape of the reflective part used shall be such that in each direction, corresponding to one of the areas defined in the figure below, visibility is ensured by a surface area of at least 18 cm² of simple shape and measured by application on a plane.

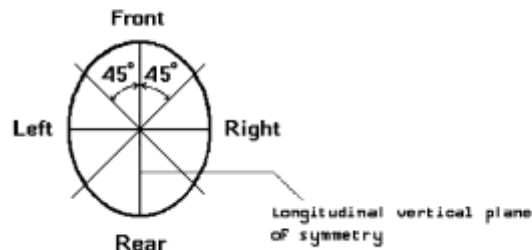

In each surface area of minimum 18 cm² it shall be possible to mark:

either a circle of 40 mm diameter;
or, a rectangle at least 12.5 cm² in surface area and at least 20 mm in width.

Each of these surfaces shall be situated as near as possible to the point of contact with the shell of a vertical plane parallel to the longitudinal vertical plane of symmetry, to the right and to the left, and as near as possible to the point of contact with the shell of a vertical plane perpendicular to the longitudinal plane of symmetry, to the front and to the rear.

6.18.3. Colorimetric test

Each of the retroreflective areas shall emit white light when it is illuminated with a standard illuminant A, with an observation angle of $1/3^\circ$ and an illumination angle $\beta_1 = \beta_2 = 0^\circ$ (or $\beta_1 = \pm 5^\circ$, $\beta_2 = 0^\circ$); in other words: the color value chart "x" and "y" of the reflected light shall lie within the zone specified below:

White:

limit towards blue	$x \geq 0.310$
limit towards yellow	$x \leq 0.500$
limit towards green	$y \leq 0.150 + 0.640x$
limit towards green	$y \leq 0.440$
limit towards purple	$y \geq 0.050 + 0.750x$
limit towards red	$y \geq 0.382$

6.18.4. Photometric test

The minimum value of the luminous intensity coefficient of a surface area of 18 cm² of material when revolved shall not be less than the values specified in the table below, expressed in millicandelas per lux.

Angle of Divergence	Angle of Illumination		
	0°	20°	40°
20'	100	60	25

6.18.5. Resistance to external agent

After each conditioning as described in paragraph 7.2., the helmet shall be visually inspected. There shall be no signs of cracking or appreciable distortion of the retroreflective material.

6.18.6. Compatibility of materials

Neither the adhesive nor the retroreflective material shall affect the mechanical performance of the helmet according to the related tests in the present Regulation.

7. TESTS

7.1. Each helmet type, fitted with its visor if placed on the market with a visor, shall be conditioned as shown below.

Test	Number of helmets to be conditioned				Total
	solvent plus ambient-temperature and hygrometry conditioning	solvent plus heat conditioning	solvent plus low-temperature conditioning	solvent plus ultra-violet radiation conditioning and moisture conditioning	
Impact absorption	2	1	1	1	5
Imp. Abs. extra point	2				2
Hi/Low energy impact	2				2
Rotational	2				2
Rigidity	2				2
Retention system	1				1
					14

The largest size of each combination shell + protective padding of each helmet type shall be tested for impact absorption, rotational and rigidity. For impact absorption on extra point, Hi and Low energy impacts and tests of the retention system, helmet sizes shall be chosen such that the helmet to be tested shall be that offering the least favorable conditions (such as thickest padding, etc).

Additionally, for each smaller headform size within the size range of the helmet type two helmets shall undergo the impact absorption test.

One helmet shall be heat conditioned, and the other low temperature conditioned. The conditioned helmets shall be impacted against either anvil, in equal numbers if possible, at the choice of the laboratory.

7.2. Types of conditioning

Prior to any type of further conditioning for mechanical tests, as specified in paragraph 7.1., each helmet shall be subject to solvent conditioning.

7.2.1. Solvent conditioning

Take a cotton cloth approximately 150 mm square and a quantity approximately 25 ml of a solvent consisting of test liquid B in accordance with ISO 1817:1985 4/. Using the cloth soaked in the solvent, apply the solvent to all those regions of the outside surface of the helmet within 50 mm of the chin strap fixings, and keep these regions wet with the solvent for (7.5 ± 2.5) s. Repeat the procedure on the remainder of the external surface including any chin guard, keeping these regions wet for (12.5 ± 2.5) s. Do not carry out any further conditioning or testing during the following 30 min.

7.2.2. Ambient-temperature and hygrometry conditioning

The helmet shall be exposed to a temperature of $25 \text{ }^\circ\text{C} \pm 5 \text{ }^\circ\text{C}$ and a relative humidity of $65\% \pm 5\%$ for at least 4 hours.

4/ e.g. 70 per cent octane and 30 per cent toluene.

7.2.3. Heat conditioning

The helmet shall be exposed to a temperature of $50\text{ }^{\circ}\text{C} \pm 2\text{ }^{\circ}\text{C}$ for not less than 4 hours and not more than 6 hours.

7.2.4. Low-temperature conditioning

The helmet shall be exposed to a temperature of $-20\text{ }^{\circ}\text{C} \pm 2\text{ }^{\circ}\text{C}$ for not less than 4 hours and not more than 6 hours.

7.2.5. Ultraviolet-radiation conditioning and moisture conditioning

The outer surface of the protective helmet shall be exposed successively to:

7.2.5.1. ultraviolet irradiation by a 150-watt xenon-filled quartz lamp for 48 hours at a range of 25 cm

7.2.5.2. spraying for 4 to 6 hours with water at ambient temperature at the rate of 1 litre per minute.

7.3. Impact-absorption tests - linear

7.3.1. Description of test

7.3.1.1. Principle

Impact absorption capacity is determined by recording against time the acceleration imparted to a headform fitted with the helmet, when dropped in guided free fall at a specific impact velocity upon a fixed steel anvil.

7.3.1.2. Marking of points and areas of impact

Before conditioning, the points and areas of impact are marked as indicated in paragraph 7.3.4.2. and annex 4 (fig. 3) and the helmet is positioned in accordance to annex 5.

Insert supplementary points on annex 4

7.3.1.3. Positioning of the helmet

After conditioning:

The helmet shall be positioned in accordance with the requirements of annex 5 on a headform of appropriate size selected from among those listed in paragraph 7.3.3.2. 5/ When testing impact points B, X, P and R the helmet is tipped towards the rear so that the front edge of the helmet in the median plane is displaced by 25 mm; the retention system is then adjusted under the chin of the headform; if the system includes an adjustable chin strap, the strap is tightened as for normal use.

5/ Helmets of sizes not listed in paragraph 7.3.3.2. shall be tested with the next smaller headform listed. Helmets of size 62 or larger shall be tested with the headform "O".

"Tightened as for normal use" means that the helmet must be tightened after having applied below the chin a rigid cylinder 10 mm diameter at least 30 mm long that will be removed before the test.

- 7.3.1.3.1.1. When testing impact point S on a helmet with a protective lower face cover, the helmeted headform is tipped forwards so that the central vertical axis of the headform is inclined at an angle of $65 \pm 3^\circ$ to the vertical with the vertical longitudinal plane of symmetry of the helmeted headform in the vertical position. If the impact point would be within 15 mm of the rim, the helmeted headform shall be re-positioned so that the impact point is not less than 15 mm from the rim.
- 7.3.1.3.2. The test headform shall be so positioned that the designated point on the helmet is vertically above the centre of the anvil. The plane tangential to the point of impact shall be horizontal. This prescription does not apply for the S impact point.
- 7.3.1.3.3. Helmets placed on the market with a visor shall be tested with the visor in the closed position.
- 7.3.1.3.4. Helmets placed on the market with a sun shield shall be tested with the sun shield in working position.

7.3.1.3.5. Helmets placed on the market with accessories shall be examined to assess that the supplementary equipment have not adverse effect and that in any case the protective helmet and/or visor still complies with all the requirements.

Note: The evaluation shall be done with and without the accessory and their support with particular attention, as example, to energy absorption, sharp edges and field of vision.

7.3.1.4. Test

The test shall be completed not more than five minutes after the helmet is taken from the conditioning chamber. Tests at point S shall be carried out after tests at points B, X, P and R. The drop height shall be equal to:

7.5 (+ 0.15/- 0.0) m/s for both anvils specified in paragraphs 7.3.2.3.1. and 7.3.2.3.2.

5.5 (+ 0.15/ -0.0) m/s for tests at point S.

[8.2] (+ 0.15/- 0.0) m/s for linear high energy
[Only flat anvil]

6.0 (+ 0.15/ -0.0) m/s for linear low energy [anvils
?]

7.3.1.5. Measurements

The velocity of the moving mass is measured between 1 cm and 6 cm before impact, to an accuracy of 1 per cent. The acceleration against time at the centre of gravity of the headform is measured and recorded and the Head Injury Criterion (HIC) calculated as prescribed in paragraph 7.3.2.5.

7.3.2. Apparatus (see annex 8, fig. 1)

7.3.2.1. Description

The test apparatus shall comprise:

- (a) An anvil rigidly fixed to a base;
- (b) A free fall guidance system;
- (c) A mobile system supporting the helmeted headform;
- (d) A metal headform fitted with a tridirectional accelerometer and a measuring assembly;
- (e) A system by which the point of impact can be brought into correspondence with the centre of the anvil.

7.3.2.2. Base

The base shall be made of steel or concrete or a combination of these materials and have a mass of at least 500 kg.

It shall be so constructed that there is no significant deformation of the surface under the test load.

No part of the base or anvil shall have a resonance frequency liable to affect the measurements.

7.3.2.3. Anvils

7.3.2.3.1. The flat steel anvil shall have a circular impact face of diameter 130 mm \pm 3 mm.

7.3.2.3.2. The kerbstone anvil shall have two sides forming an angle of $105 \pm 5^\circ$, each of them with a slope of $52.5 \pm 2.5^\circ$ towards the vertical and meeting along a striking edge with a radius of 15 mm \pm 0.5 mm. The height must be at least 50 mm and the length not less than 125 mm. The orientation is 45° to the longitudinal vertical plane at points B, P, R, and extra points, 45° to the base plane at point X (front low, back up).

7.3.2.4. Mobile system and guides

The mobile system supporting the headform shall be such that its characteristics do not affect the measurement of acceleration at the centre of gravity of the headform. It shall also be such that any point in the area ACDEF can be positioned vertically above the centre of the anvil.

The guides shall be such that the impact velocity is not less than 95 per cent of the theoretical velocity.

7.3.2.5. Accelerometer and measuring assembly

The accelerometer shall be capable of withstanding a maximum acceleration of 2,000 g without damage. Its maximum mass shall be 50 grammes. The measuring system, including the drop assembly, shall have a frequency response in accordance with channel frequency class (CFC) 1000 of the International Standard ISO "Road vehicles - Techniques of measurement in impact tests - Instrumentation" (Ref. No. ISO 6487:1980).

The HIC shall be calculated as the maximum (depending from t_1 and t_2) of the equation:

$$HIC = \left[a^2 \int_{t_1}^{t_2} a(t) dt \right]^2 (t_2 - t_1)$$

where 'a' is the resultant acceleration as a multiple of 'g' and t_1 and t_2 are any two points in time (sec) during the impact. The acceleration data has to be sampled at a frequency of at least 8,000 Hz and filtered in accordance with the latest edition of ISO 6487 (CFC 1000).

7.3.3. Headforms

The headforms shall be made of metal and, together with any means for their support, shall exhibit no resonance below a frequency of 2000 Hz.

Full headforms shall have the following characteristics:

a) the centre of gravity shall be located within a 10 mm radius of point G on the central vertical axis;

b) a facility for attaching an accelerometer shall be incorporated such that, with the headform in any angular orientation, the respective sensitive axes of the accelerometer shall pass within 10 mm of point G;

c) the appropriate mass, as specified in Table [below].

7.3.3.1. The general characteristics of the test headforms to be used shall be as follows:

Symbols	Circumference (in mm)	Mass (in Kg)
A	495	3.1 (±0.10)
C	515	3.6 (±0.10)
E	535	4.1 (±0.10)
J	575	4.7 (±0.10)
M	605	5.6 (±0.10)
O	625	6.1 (±0.10)

7.3.3.2. The shape of the test headforms shall be in conformity with the detailed dimensions of the reference headforms shown in annex 6;

7.3.3.3. For tests other than those of impact-absorption, appropriate full headforms complying only with the geometrical provisions of paragraph 7.3.3.2. above, may be used.

7.3.4. Selection of points of impact

7.3.4.1. Each test shall be carried out with 4 impacts on one helmet on the points B, X, P and R, in this sequence. When a helmet with

a protective lower face cover is being tested then an additional point S shall be impacted after the four other points, but only against the anvil specified in paragraph 7.3.2.3.1.

Other test samples can be used for additional linear impact on extra point.

7.3.4.1.1. After each impact the helmet shall be re-positioned correctly on the headform prior to the next impact, without interfering with the adjustment of the retention system. Before each impact on the point S the helmet shall be re-positioned correctly on the headform and the retention system adjusted under the chin of the headform; if the system includes an adjustable chin strap, the strap is tightened as much as possible.

7.3.4.2. The points of impact are defined for each helmet:

- B, in the frontal area, situated in the vertical longitudinal plane of symmetry of the helmet and at an angle of 20° measured from Z above the AA' plane.
- X, in either the left or right lateral area, situated in the central transverse vertical plane and 12.7 mm below the AA' plane.
- R, in the rear area, situated in the vertical longitudinal plane of symmetry of the helmet and at an angle of 20° measured from Z above the AA' plane.
- P, in the area with a radius of 50 mm and a centre at the intersection of the central vertical axis and the outer surface of the helmet shell.
- S, in the lower face cover area, situated within an area bounded by a sector of 20° divided symmetrically by the vertical longitudinal plane of symmetry of the helmet.

Impacts at points B, X and R should be within 10 mm radius of the defined point.

EXTRA POINT

Up to 4 impact tests shall be performed on a helmet sample. The impact points shall be selected among the 12 points as listed below and depicted in figure. The selected impact points shall not be less than 120 mm apart.

BP - in the front-superior area, situated in the vertical longitudinal plane of symmetry of the helmet (0°) situated in the vertical plane and at an angle of 45° measured from Z above the AA' plane.

BXL - in the left (315°) front-lateral area, situated in the vertical plane and at an angle of 20° measured from Z above the AA' plane.

BXR - in the right (45°) front-lateral area, situated in the vertical plane and at an angle of 20° measured from Z above the AA' plane.

BXPL - in the left (315°) front-lateral-superior area, situated in the vertical plane and at an angle of 45° measured from Z above the AA' plane.

BXPR - in the right (45°) front-lateral-superior area, situated in the vertical plane and at an angle of 45° measured from Z above the AA' plane.

XPL - in the left (270°) lateral-superior area, situated in the central transverse vertical plane and at an angle of 45° measured from Z above the AA' plane.

XPR - in the right (90°) lateral-superior area, situated in the central transverse vertical plane and at an angle of 45° measured from Z above the AA' plane.

RXL - in the left (225°) rear-lateral area, situated in the vertical plane and at an angle of 20° measured from Z above the AA' plane.

RXR - in the right (135°) rear-lateral area, situated in the vertical plane and at an angle of 20° measured from Z above the AA' plane.

RXPL - in the left (225°) rear-lateral-superior area, situated in the vertical plane and at an angle of 45° measured from Z above the AA' plane.

RXPR - in the right (135°) rear-lateral-superior area, situated in the vertical plane and at an angle of 45° measured from Z above the AA' plane.

RP - in the rear-superior area, situated in the vertical longitudinal plane of symmetry of the helmet (180°) and at an angle of 45° measured from Z above the AA' plane.

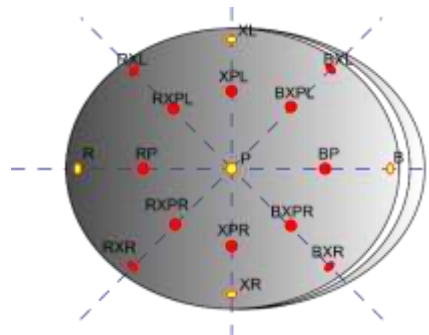

Any other point inside the extent of protection [§ 6.4.1] as particular ventilation holes and/or special features on helmet should be considered.

7.3.5. Combination of conditioning and anvils

Conditioning: Solvent plus ...	Anvils <u>a/</u>
Ambient	Flat and kerbstone
Heat	Kerbstone <u>b/</u>
Low temperature <u>c/</u>	Flat <u>b/</u>
Ultraviolet radiation and moisture	Flat or kerbstone (to be selected by the laboratory)

- a/ Point S shall only be impacted against the flat anvil.
b/ Only for the largest helmet size. For smaller headforms in the size range of the helmet type either anvil may be used. See paragraph 7.1.
c/ Only each helmet size subjected to low-temperature conditioning shall undergo the impact test at point S.

7.3.6. The absorption efficiency shall be considered sufficient where the resultant acceleration measured at the centre of gravity of the headform at no time exceeds:

Type of test	Acceleration	HIC
Linear Impact Std	≤ 275 g	≤2400
Linear Extra Point	≤ 275 g	≤2400
Linear Hi Energy	≤ 275 g	≤2880
Linear Low Energy	≤ [180 g]	≤[1000]

The helmet shall not become detached from the headform.

7.4 Test for projections and surface friction

An appropriate size of helmet shall be subjected to the test described in paragraph 7.4.1. or to the test described in paragraph 7.4.2.

7.4.1. Test for projections and surface friction (method A)

7.4.1.1. Description of test

7.4.1.1.1. Principle

The rotation-inducing forces caused by projections on the helmet and friction against the outer surface of the helmet which occur when a helmeted headform is dropped vertically on to an inclined anvil are measured in the longitudinal axis of the anvil. The peak force and its integral with respect to time over the duration of the positive impulse are used as performance criteria.

7.4.1.1.2. Selection and positioning of the helmet

7.4.1.1.2.1. An appropriate size helmet shall be selected to fit the headform referred to in paragraph 7.4.1.2.6. The horizontal axis of the helmet shall be determined by placing the helmet on a headform, of a type referred to in paragraph 7.3.3., according to the requirements of annex 5. The helmet shall then be removed from that headform and placed on a headform of a type referred to in paragraph 7.4.1.2.6. A load of 50 N is applied to the crown of the helmet in order to adjust the helmet on the headform such that there is contact between the crown of the headform and the inner surface of the helmet.

The horizontal plane of the helmet shall then be adjusted to be within $90^\circ \pm 5^\circ$ of the vertical axis of the headform. The retention system is then adjusted under the chin of the headform; if the system includes an adjustable chin strap, the strap is tightened as much as possible.

7.4.1.1.2.2. The test headform shall be so positioned that the chosen impact point on the helmet is vertically above the upper part of the face of the anvil.

7.4.1.1.2.3. The helmet shall be tested in any condition in which it may be placed on the market, that is both with and without accessories if they are supplied as original equipment. Helmets placed on the market with a visor shall be tested with the visor in the closed position.

Helmets of the category "P/J" or "NP/J" shall be tested in all the configurations provided by the manufacturer.

7.4.1.1.3. Test

The drop height shall be such that the unit constituted by the headform and helmet falls on the test anvil at a velocity which, immediately before impact, is equal to 8.5 (-0.0/+0.15) m/s.

7.4.1.2. Apparatus (see annex 8, fig. 1b)

7.4.1.2.1. Description

The test apparatus shall comprise:

- (a) An anvil rigidly fixed to a base;
- (b) A free fall guidance system;
- (c) A mobile system supporting the helmeted headform;
- (d) A headform conforming to that referred to in paragraph 7.4.1.2.6., and
- (e) A system which may be adjusted such that the point of impact can be brought into correspondence with the upper part of the face of the anvil.
- (f) A means of recording the continuously changing transmitted anvil force during the impact.
- (g) A suitable energy-absorbing base and catch net to prevent damage to the helmet after the impact.

7.4.1.2.2 Base

This shall conform to the requirements specified in paragraph 7.3.2.2.

7.4.1.2.3. Anvil

7.4.1.2.3.1. The anvil is mounted securely at an angle of 15° to the vertical with provision for fore-and-aft adjustment. The anvil has a minimum width of 200 mm and is adaptable to carry either of two different impact surfaces as follows:

7.4.1.2.3.1.1. The bar anvil consists of a series of at least 5 horizontal bars at 40 mm centres. Each bar is made from a steel strip of height 6 mm and width 25 mm with its uppermost edge machined to a 1 mm radius and the lower 15 mm of its face chamfered at an angle of 15° so that, as mounted, the upper edge of each bar is fully exposed from vertically above. The bars are case-hardened to a depth of approximately 0.5 mm.

The bar anvil should be used to assess the tangential forces and their integrals with time caused by projections on the helmet, e.g. visor fittings, screws, press studs and steps in the shell surface, etc.

7.4.1.2.3.1.2. The abrasive anvil is a sheet of grade 80 closed-coat aluminium oxide abrasive paper with a minimum supported length of 225 mm and is securely clamped to the base of the anvil to prevent slippage.

The abrasive anvil should be used to assess the tangential forces and their integrals with time caused by friction against the outer surface of the helmet. This is particularly applicable to selected areas of helmets, the outer surface of which either have significant variations of curvature or are made of more than one material.

7.4.1.2.3.2. The anvil is fitted with force transducer(s) connected to recording apparatus so that the transmitted longitudinal force component can be measured and continuously recorded with an accuracy of ± 5 per cent during a glancing blow to any part of its exposed surface.

7.4.1.2.4. Mobile system and guides

The mobile system supporting the headform shall be such that its characteristics do not affect the measurement of force in the anvil. It shall also be such that any point on the helmet can be positioned vertically above the anvil. The guides shall be such that the impact velocity is not less than 95 per cent of the theoretical velocity.

7.4.1.2.5. Force and measuring assembly

The force transducers fitted to the anvil shall be capable of withstanding a maximum force of 20,000 N without damage.

The measuring system including the anvil assembly shall have a frequency response in accordance with channel frequency class (CFC) 1 000 of the International Standard ISO "Road vehicles - Techniques of measurement in impact tests - Instrumentation" (Ref. No. ISO 6487:1980).

7.4.1.2.6. Headform

The headform shall be that referred to in paragraph 7.3.3. characterized by the symbol J.

7.4.1.3. Selection of impact points

Any point on the helmet may be selected. The impact point should be selected with regard to the anvil against which the helmet is to be tested, taking into account the function of the anvils given in paragraphs 7.4.1.2.3.1.1. and 7.4.1.2.3.1.2. The helmet shall be tested as many times as necessary to ensure that all notable features are evaluated.

When the abrasive anvil is used, evaluate the front, rear, sides and crown areas of the helmet, selecting within these general areas, sites on the outer surface which are likely to produce the greatest force and/or the greatest impulse where impulse is the integral of force with respect to time over the duration of the impact. Examples of such areas are those having the greatest radius of curvature (i.e. the flattest surface) or areas having more than one type of surface, for example a visor fixing cover plate or a painted shell partially overlaid by a fabric cover.

Note: The primary impact site on any projection is likely to be opposite to the site where the projection receives maximum support. For example, the primary impact site on a visor cover plate assembly is opposite to the area where the visor and cover plate locates in a recess in the shell.

When the abrasive anvil is used, evaluate the front, rear sides and crown areas of the helmet, selecting within the general areas, sites on the outer surface which are likely to produce the greatest force and/or the greatest impulse where impulse is the integral of force with respect to time over the duration of the impact. Examples of such areas are those having least curvature or areas having more than one type of surface finish, for example a painted shell partially overlaid by a fabric cover.

The rim of the shell and the upper and lower edge of the visor situated within an area bounded by a sector of 120° divided symmetrically by the vertical longitudinal plane of symmetry of the helmet do not constitute a projection for the purpose of this test.

7.4.1.4. Requirements

7.4.1.4.1. When tested against the bar anvil the helmet shall satisfy the following requirements:

7.4.1.4.1.1. the peak longitudinal force measured on the anvil shall not exceed 2,500 N, nor shall its integral with respect to time over the duration of the impact exceed 12.5 Ns for any of the selected impact points.

7.4.1.4.2. When tested against the abrasive anvil, a second helmet shall satisfy the following requirements:

7.4.1.4.2.1. the peak longitudinal force measured on the anvil shall not exceed 3,500 N, nor shall its integral with respect to time over the duration of the impact exceed 25 Ns for any of the selected impact points.

7.4.2. Test for projections and surface friction (method B)

7.4.2.1. Description of test

7.4.2.1.1. Principle

The rotation-inducing forces caused by projections on the helmets and friction against the outer surface of the helmets are assessed firstly by a shear impact on the projections using a shear edge against which the projections shall shear away, be detached, or permit the shear edge to slide past the projections. The friction is assessed by the displacement of a carriage abrading the outer surface of the helmet. The shear impact and abrading carriage displacement are generated by a drop weight device.

7.4.2.1.2. Positioning of the helmets

7.4.2.1.2.1. The helmet is placed on a headform of appropriate size in accordance with the requirements of annex 5. The helmet is tipped towards the rear so that the front edge of the helmet in the median plane is displaced by 25 mm; if the helmet includes an adjustable chin strap, the strap shall be tightened as much as possible. The headform shall be so positioned that the chosen location on the helmet can be positioned in contact with the upper surface of the horizontal carriage.

7.4.2.1.2.2. The helmet shall be tested in any condition in which it may be placed on the market, that is both with and without accessories if they are supplied as original equipment. Helmets placed on the market with a visor shall be tested with the visor in the closed position.

[Helmets of the category "P/J" or "NP/J" shall be tested in all the configurations provided by the manufacturer.](#)

7.4.2.1.3. Test

7.4.2.1.3.1. Test of projection

The headform is adjusted in order to have the chosen projection on the carriage so that the shear edge is positioned 50 mm from the projection and makes lateral contact with the projection after the drop weight is released from its upper position.

7.4.2.1.3.2. Test of outer surface

The abrasive paper is mounted on the carriage in the position specified in paragraph 7.4.2.2.2. The chosen outer surface of the helmet is lowered on to the abrading carriage at the centre of the flat surface without abrasive paper. A loading mass is applied in accordance with paragraph 7.4.2.2.8. The drop weight is released from its upper position in accordance with paragraph 7.4.2.2.5. The abrasive paper shall be changed after every test.

7.4.2.2. Apparatus (a suitable apparatus is illustrated in annex 8, figure 1c)

7.4.2.2.1. Description

The test apparatus shall comprise:

- (a) A horizontal guided carriage with interchangeable attachments for abrasive paper or a shear edge;
- (b) A horizontal guide and support for this carriage;
- (c) A roller with a wire rope or a strap or a similar flexible connection;
- (d) A lever connecting the headform to the test apparatus with a hinge;
- (e) An adjustable system supporting the headform;
- (f) A drop weight to load the lower end support of the wire rope, or a strap, after the weight is released;
- (g) A system to support a headform and to apply a force to the helmet normal to the carriage.

7.4.2.2.2. Carriage

For friction assessment the carriage bears a sheet of grade 80 closed-coat aluminum oxide abrasive paper with a supported length of 300.0 (- 0.0/+ 3.0) mm and securely clamped to the carriage to prevent slippage. At its end towards the drop weight and in this direction the carriage has a 80 mm \pm 1 mm long smooth steel area not being covered by the abrasive paper and higher than the rest of the carriage by the thickness of the abrasive paper plus 0.5 \pm 0.1 mm.

For shear assessment the carriage is provided in the middle, with a bar made from a steel strip of height 6 mm and width 25 mm with its uppermost edges machined to a 1 mm radius. The bar is case-hardened to a depth of approximately 0.5 mm.

The carriage and either attachment shall have a total mass of 5.0 (- 0.2/+ 0.0) kg.

7.4.2.2.3. Horizontal guide

The horizontal guide which guides and supports the carriage may consist of two cylindrical bars on which the ball bearings of the carriage may freely travel.

7.4.2.2.4. Roller with a wire rope or strap

The rollers shall have a diameter of at least 60 mm and lead the wire rope or strap from the horizontal into the vertical direction. The horizontal end of the wire rope or strap is fixed to the carriage, the vertical end is fixed to the drop weight.

7.4.2.2.5. Drop weight

The drop weight shall have a mass of 15.0 (- 0.0/+ 0.5) kg. For shear assessment the free drop height shall be 500.0 (- 0.0/ + 5.0) mm with provision for further possible travel of at least 400 mm. For testing the friction assessment, the free drop height shall be 500.0 (- 0.0/+ 5.0) mm with provision for further possible travel of at least 400 mm.

7.4.2.2.6. Headform support

The system supporting the headform shall be such that any point on the helmet can be positioned in contact with the upper surface of the carriage.

7.4.2.2.7. Lever and hinge

A rigid lever shall connect the headform support to the test apparatus with a hinge. The height of the hinge pivot above the upper surface of the carriage shall not be greater than 150 mm.

7.4.2.2.8. Loading mass

A loading system is used to generate a force of 400.0 (- 0.0/+ 10.0) N on the helmet normal to the surface of the carriage. This force shall be measured before each test.

7.4.2.2.9. Verification of the test apparatus

With the unloaded carriage and a drop height of up to 450 mm, the velocity of the carriage after 250 mm of travel shall be 4.0 ± 0.1 m/sec. This requirement shall be verified after every 500 helmet tests or once every 3 months whichever is sooner.

7.4.2.3. Selection of test points

Any point on the helmet may be selected for friction and/or shear assessment. A helmet shall be tested as many times as necessary to ensure that all notable features are evaluated with one test only per feature. Re-orientate the helmet as necessary to allow every feature to be tested. For shear assessment evaluate all different external projections greater than 2 mm above the outer surface of the shell. For friction assessment evaluate areas of the outer surface that are likely to produce the greatest friction.

The rim of the shell and the upper and lower edge of the visor situated within an area bounded by a sector of 120° divided symmetrically by the vertical longitudinal plane of symmetry of the helmet do not constitute a projection for the purpose of this test.

7.4.2.4. Requirements

7.4.2.4.1. For shear assessment the tested projection shall shear away, be detached or alternatively shall not prevent the assessment bar from sliding past the projection. In all cases the bar on the horizontal carriage shall travel past the projection.

7.4.2.4.2. For friction assessment the abrasive carriage shall not be brought to rest by the helmet.

7.4.3. Test for projections of the category P/J with movable lower face cover

7.4.3.1. The helmet, shall be placed on the appropriate test head form selected from annex 4 in compliance with paragraph 7.3.1.3.1

7.4.3.2. A device to guide and release a falling mass (the total mass being 3 kg ± 0.1 kg) is hooked on to the front part of the chin section in the position "J" in the median vertical plane of the helmet (shown in annex 8, tested reversely)

7.4.3.3. The falling mass of 10 kg ± 0.01 kg is then released and drops in a guided free fall from a height of 0.50 m ± 0.01 m. The guiding devices shall be such as to ensure that the impact speed is not less than 95 per cent of the theoretical speed

7.4.3.4. For strength assessment of the movable face cover in the position "J", the movement must be such to avoid any possible interference with 100 mm cylinder as defined in § 6.4.2. The chin guard may detach completely from the helmet.

7.5. Rigidity tests

7.5.1. The helmet, after undergoing ambient-temperature and hygrometry conditioning, shall be placed between two parallel plates by means of which a known load can be applied along the longitudinal axis 6/ (line LL in the figure) or the transverse axis (line TT in the figure). The surface of the plates shall be large enough to contain a circle of at least 65 mm in diameter. An initial load of 30 N shall be applied, at a minimum plates speed of 20 mm/min, and after two minutes the distance between the two plates shall be measured. The load shall then be increased by 100 N, at a minimum plates speed of 20 mm/min, and then wait for two minutes. This procedure shall be repeated until the application of a load of 630 N.

6/ During the test along the longitudinal axis, the contact point between the helmet and one of the two plates must be the "B" impact point.

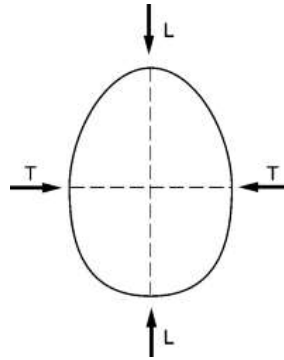

- 7.5.2. The load applied to the plates shall be reduced to 30 N, at a minimum plates speed of 20 mm/min; the distance between the plates shall then be measured.
- 7.5.3. The helmet used for the test along the longitudinal axis shall be a new helmet, and another new helmet shall be used for the test along the transverse axis.
- 7.5.4. In the test along each axis, the deformation measured under the 630 N load shall not exceed that measured under the initial 30 N load by more than 40 mm.
- 7.5.5. After restoration of the 30 N load, the deformation measured shall not exceed that measured under the initial 30 N load by more than 15 mm.
- 7.5.6. In the event of cracks or breakage of the shell during the impact tests, the rigidity test may be repeated on the damaged helmets to evaluate the residual mechanical characteristics. In this case the maximum deformation measured must be more than [70%] of the value detected on the intact helmet.
- 7.6. Dynamic test of the retention system (see annex 8, figure 2)
- 7.6.1. The helmet shall be positioned as prescribed in paragraph 7.3.1.3.1. above.
- 7.6.2. In this position the helmet is held by the shell at a point traversed by the vertical axis passing through the centre of gravity of the headform. The headform is equipped with a load-bearing device aligned with the vertical axis passing through the centre of gravity of the headform and with a device to measure the vertical displacement of the point of application of the force. A guide and arrest device for a falling mass shall then be attached below the headform. The mass of the headform so equipped shall be 15 kg \pm 0.5 kg, which shall be the pre-loading on the retention system for determining the position from which the vertical displacement of the point of application of the force shall be measured.
- 7.6.3. The falling mass of 10 kg \pm 0.1 kg shall then be released and shall drop in a guided free fall from a height of 750 \pm 5 mm.
- 7.6.4. During the test, the dynamic displacement of the point of application of the force shall not exceed 35 mm.

- 7.6.5. After two minutes, the residual displacement of the point of application of the force, as measured under a mass of 15 kg \pm 0.5 kg, shall not exceed 25 mm.
- 7.6.6. Damage to the retention system shall be accepted provided that it is still possible to remove the helmet easily from the headform. In the case of retention systems fitted with quick release mechanisms it must be possible to release the mechanism in accordance with paragraphs 7.11.2. to 7.11.2.2. The specifications set out in paragraphs 7.6.4. and 7.6.5. shall be met.
- 7.7. Retention (detaching) test
- 7.7.1. The helmet, previously conditioned at ambient temperature and hygrometry, is attached to the appropriate headform, selected from those listed in annex 4, in accordance with the requirements of paragraph 7.3.1.3.1. of this Regulation.
- 7.7.2. A device to guide and release a falling mass (the total mass being 3 kg \pm 0.1 kg) is hooked on to the rear part of the shell in the median vertical plane of the helmet, as shown in annex 8, figure 3.
- 7.7.3. Before the test, the retention system must be capable to maintain the helmet on the headform when a preload of [13 kg \pm 0.01 kg] is hooked to the front border of the shell in the median vertical plane of the helmet, reverse test.
- 7.7.4. The falling mass of 10 kg \pm 0.01 kg is then released and drops in a guided free fall from a height of 0.50 m \pm 0.01 m. The guiding devices shall be such as to ensure that the impact speed is not less than 95 per cent of the theoretical speed.
- 7.7.5. After the test the angle between the reference line situated on the shell of the helmet and the reference plane of the headform shall not exceed 30°.
- 7.7.6. In modular helmets the test must be done in J and P configuration.

7.8. Visor tests

7.8.1. Sampling and use of samples

The 7 (+3 if optional test) visors are used as follows:

Paragraph	Test	1	2	3	4	5	6	7	7	8	9	10	Total	
									If optional test					
6.15.3.	Field of vision of the visor	X						R E T A I N E D				R E T A I N E D	1	
6.15.3.4.	Luminous transmittance	X	X	X										3
6.15.3.5.	Light diffusion													
6.15.3.6.	Recognition of signal lights													
6.15.3.7.	Spectral transmittance													
6.15.3.8.	Refractive powers				X	X	X							3
6.15.3.9.	Mist retardant visor (optional)								X	X	X			3
7.8.2.	Mechanical characteristics				X	X	X						3	
7.8.3.	Optical quality and scratch Resistance	X	X	X									3	

Note: The test for recognition of signal lights may be dispensed with in the case of visors with luminous transmittance $\tau_v \geq 80\%$.

7.8.1.1. Prior to any type of further conditioning for mechanical or optical test, as specified in paragraph 7.8.1., each visor shall be subject to the ultraviolet conditioning in accordance with the provision of paragraph 7.2.5.1.

7.8.2. Mechanical characteristics

7.8.2.1. The helmet, fitted with its visor and previously conditioned in accordance with the provisions of paragraph 7.2.4., shall be placed in accordance with the provisions of paragraph 7.3.1.3.1. on a test headform of suitable size. The test headform selected from among those shown in annex 4 shall be so placed that the basic plane is vertical.

7.8.2.2. The test apparatus used shall be as described in paragraph 7.8.2.2.1., the metal punch being placed in contact with the visor in the vertical symmetrical plane of the headform to the right of point K. The apparatus shall be designed in such a way that the punch is stopped not less than 5 mm above the headform.

7.8.2.2.1. The testing device mentioned in paragraph 7.8.2.2. above shall have the following characteristics:

Mass of punch 0.3 kg \pm 10g

Angle of cone forming punch head 60° \pm 1°

Radius of rounded top of punch head 0.5 mm

Mass of the drop hammer 3 kg \pm 25 g

7.8.2.3. When the drop-hammer falls from a height of 1 + 0.005 m, measured between the top face of the punch and the lower face of the hammer, it shall be ascertained that:

7.8.2.3.1. no sharp splinters are produced if the visor is shattered. Any segment having an angle less than 60° shall be considered as a sharp splinter.

Insert High Speed particle EN 166:2001? Conditioning?

7.8.3. Optical qualities and scratch resistance

7.8.3.1. Test procedure

7.8.3.1.1. The test piece shall be taken from the flattest part of the visor in the area specified in paragraph 6.15.3.2. and its minimum dimensions shall be 50 mm x 50 mm. The test shall be carried out on the face corresponding to the outside of the visor.

7.8.3.1.2. The test piece shall undergo ambient-temperature and hygrometry conditioning in accordance with paragraph 7.2.2.

7.8.3.1.3. The test shall comprise the following sequence of operations:

7.8.3.1.3.1. The surface of the test piece shall be washed in water containing 1 per cent detergent and rinsed with distilled or demineralized water, then carefully dried with a grease-free and dust-free linen cloth.

7.8.3.1.3.2. Immediately after drying and before abrasion, the luminous transmittance shall be measured using the method given in paragraph 7.8.3.2.1.1., and the light diffusion shall be measured according to one of the methods specified in annex 11.

7.8.3.1.3.3. The test piece shall then be subjected to the abrasion test described in annex 10, during which 3 kg \pm 0,01 kg of abrasive material shall be projected at the sample.

7.8.3.1.3.4. Following the test, the test piece shall again be cleaned in accordance with paragraph 7.8.3.1.3.1.

7.8.3.1.3.5. Immediately after drying the light diffusion after abrasion shall be measured by using again the same method used in accordance with paragraph 7.8.3.1.3.2. above.

7.8.3.2. Requirements

7.8.3.2.1. Three similar test pieces, each from a different visor and taken from the area specified in paragraph 6.15.3.2., shall meet the requirements of paragraphs 7.8.3.2.1.1. and 7.8.3.2.1.2.

7.8.3.2.1.1. In a parallel beam, with the test specimens being irradiated vertically, determine the spectral transmittance values between 380 nm and 780 nm and then the transmittance and the visual attenuation quotient in accordance with the equations given in annex 13.

To calculate the luminous transmittance, the spectral distribution of standard illuminant D65 and the spectral values of the colorimetric 2° standard observer CIE 1931 according to ISO/CIE 10526 shall be used. The product of the spectral distribution of standard illuminant D65 and the spectral values of the colorimetric 2° standard observer CIE 1931 according to ISO/CIE 10526 is given in annex 14. Linear interpolation of these values for steps smaller than 10 nm is permissible.

7.8.3.2.1.2. The light diffusion shall not exceed the following values for each method:

Before abrasion		After abrasion	
0.65 cd/m ² /1	<u>a/</u> <u>c/</u>	5.0 cd/m ² /1	<u>a/</u> <u>c/</u>
2.5%	<u>b/</u>	10%	<u>b/</u>

a/ measured according to annex 11, method (a);
b/ measured according to annex 11, method (b);
c/ measured according to annex 11, method (c).

7.9. Sun shield tests

7.9.1. Sampling and use of samples

The 7 sun shield are used as follows:

Paragraph	Test	1	2	3	4	5	6	7	Total
6.17.2	Field of vision of the sun shield	X							1
6.17.2.2 6.17.2.3 6.17.2.4 [6.16.2.5]	Luminous transmittance Recognition of signal lights Spectral transmittance	X	X	X					3
6.16.2.6	Refractive powers				X	X	X		3

7.9.1.1. Prior to any type of further conditioning for mechanical or optical test, as specified in paragraph 7.9.1., each sun shield shall be subject to the ultraviolet conditioning in accordance with the provision of paragraph 7.2.5.1.

- 7.9. Micro-slip test of the chin strap (see annex 8, Figure 4)
- 7.9.1. The test rig consists of a flat horizontal robust base, a weight for applying a load, a freely rotatable horizontal roller of diameter not less than 20 mm, and in the same horizontal plane as the top of the roller a clamp capable of reciprocating horizontal motion at right angles to the axis of the roller with a total amplitude of 50 ± 5 mm at a frequency between 0.5 Hz and 2 Hz.
- 7.9.2. Take a sample of the strap at least 300 mm long, including the tensioning and adjusting device and any additional strap fastening. Fix the upper end of the strap to the reciprocating clamp level with the top of the roller and drape the strap over the roller. Attach a weight to the lower end of the strap so that when the weight is lifted by the strap it imposes a tensile force of 20 ± 1 N. Adjust the apparatus so that when the reciprocating clamp is at the centre of its motion the weight is just resting on the base with the strap barely in tension and the strap buckle is between the clamp and roller and will not touch the roller during reciprocation.
- 7.9.3. Operate the reciprocating clamp for 20 cycles. Note the position of the components on the strap. Operate the reciprocating clamp for 500 cycles then record the distance through which the components have slipped along the strap.
- 7.9.4. The total slippage through the grip shall not exceed 10 mm.
- 7.10. Test for resistance to abrasion of the chin strap (see annex 8, Figure 5)
- The test shall be performed on every device in which the strap slides through a rigid part of the retention system, with the following exceptions:
- (a) where the micro-slip test, paragraph 7.9., shows that the strap slips less than half the prescribed value; or,
 - (b) where the composition of the material used, or the information already available, renders the test superfluous in the judgement of the technical service.
- 7.10.1.1. The test rig is similar to that described in paragraph 7.9.1. except that the amplitude of motion is 100 ± 10 mm and the strap passes over a representative surface of the associated adjuster or other strap fitting through an appropriate angle.
- 7.10.2. Select an arrangement of the apparatus appropriate for the particular design of both the strap and the fitting likely to cause abrasion. Grip one end of the strap in the oscillating clamp, arrange the strap to be threaded through the fitting as designed and hang a weight on the end to tension the strap with a force of 20 ± 1 N. Mount or otherwise steady the fitting in such a position that movement of the oscillating clamp slides the strap through the fitting, in a manner simulating slippage of the fitting on the strap when the helmet is on the head.
- 7.10.3. Oscillate the clamp for a total of 5,000 cycles at a frequency between 0.5 and 2 Hz.

- 7.10.4. Mount the abraded strap in a tensile testing machine using clamps which avoid local breakage of the strap, and so that there is a length of 150 ± 15 mm of strap, including the abraded portion, between the clamps. Operate the machine to stretch the strap at a speed of 100 ± 20 mm per minute.
- 7.10.5. The strap shall withstand a tension of 3 kN without breaking.
- 7.11. Tests for retention systems relying on quick-release mechanisms
- 7.11.1. Inadvertent release by pressure
- 7.11.1.1. If the retention system is designed to be released by pressure on a certain part, the system shall not release when a rigid sphere of diameter 100 mm is pressed with a force of 100 ± 5 N directly in the line of movement of that part.
- 7.11.1.2. If such a system incorporates more than one quick-release mechanism, or one such mechanism requiring more than one operation to release it, the system shall be deemed not to comply with this requirement if sufficient opening of the system is caused by the pressure of the sphere on only one quick-release mechanism or for only one operation, whichever is appropriate, to allow the release of the appropriate headform.
- 7.11.2. Ease of release
- 7.11.2.1. The helmet shall be mounted on the apparatus described in paragraph 7.6. such that a static force of 150 ± 5 N is applied to the retention system. An additional static force of 350 ± 5 N shall be applied to the retention system for at least 30 seconds and then removed. After the additional force has been removed, the opening system shall be capable of being operated by a force not exceeding 30 N. However, if the quick release mechanism is incorporated in the helmet shell, the opening system shall be capable of being operated by a force not exceeding 60 N.
- 7.11.2.2. The buckle opening force shall be applied using a dynamometer or similar device in the manner and direction of normal use. In the case of a push button the contact end shall be a polished metal hemisphere with radius 2.5 ± 0.1 mm. The opening force shall be applied on the geometric centre of the push button or respective application areas.
- 7.11.3. Durability of quick-release mechanisms
- 7.11.3.1. Subject the quick-release mechanism to the following procedures in the order given.
- 7.11.3.2. Using apparatus appropriate to the particular design of mechanism carry out the following procedure. Close and lock the mechanism. Apply a loading force of 20 ± 1 N in the direction in which the mechanism is designed to bear load, then unlock and disengage the mechanism under load. Complete this cycle in not less than 2 s. Repeat for a total of 5,000 cycles.
- 7.11.3.3. If the quick-release mechanism incorporates metal components carry out the following procedure:

7.11.3.4. Place the complete mechanism in a closed cabinet so that the mechanism can be continuously wetted by a spray while still allowing free access of air to all parts of the mechanism. Subject the mechanism to a spray of a solution consisting of 5 ± 1 per cent (m/m) of reagent grade sodium chloride in distilled or deionized water for a period of 48 ± 1 h at a temperature of 35 ± 5 °C. Rinse the mechanism thoroughly in clean running water to remove salt deposits and allow it to dry for 24 ± 1 h.

Repeat the procedure in paragraph 7.11.3.2.

7.11.3.5. The quick release mechanism shall not fracture nor disengage when a tensile force of $2.0 \text{ kN} \pm 50 \text{ N}$ is progressively applied to the retention system in the direction in which the mechanism is designed to bear load. Following the application and removal of the force, the quick release mechanism shall still be capable of operation.

7.12. Rotational acceleration
A complete new procedure will be added (separately)

7.13. Accessories prescription

7.14. Test of Noise (Optional)
A complete new procedure will be added (separately)

7.15. Test of ventilation (optional)
A complete new procedure will be added (separately)

7.16. Test of photochromic ... visors

8. TEST REPORTS

8.1. Each technical service shall prepare reports on the results of the approval tests and keep such reports for [10] years. In the case of the impact absorption test the report shall indicate, in addition to the results of the tests, the type of conditioning and the anvil used when these are at the discretion of the technical service, and the results of the impact on the fifth site.

9. PRODUCTION QUALIFICATION

9.1. In order to make sure that the manufacturer's production system is satisfactory, the technical service which conducted the approval tests must carry out tests to qualify production in accordance with paragraphs 9.2. and 9.3.

9.2. Qualifying the production of helmets

The production of each new approved type of helmet must be subjected to production qualification tests.

For this purpose, a random sample from the first batch will be taken

of 40 helmets, to be divided into homogenous lots of 10, choosing the biggest helmet sizes for each shell size (or a lot of 50 helmets, if point S tests are included) and 10 small sized helmets. At least 2 (two) lots among those subjected to the shock-absorption test shall consist of maximum size helmets.

The first batch is considered to be the production of the first tranche containing a minimum of 200 helmets and a maximum of 3,200 helmets.

9.2.1. Test on the system of retention

9.2.1.1. The 10 helmets of the smallest size of each shell are subjected to the test of the retention system described in paragraph 7.6.2.

All the types of retention system available for the helmet must be checked.

9.2.2. Shock absorption test

9.2.2.1. From the 40 helmets (50 if the S point test is involved) take 4 (5 if the S point test is involved) groups each with 10 helmets.

9.2.2.2. All of the helmets in a group must first be subjected to the same conditioning treatment and then subjected to the shock absorption test described in paragraph 7.3. at the same point of impact. The conditioning and the anvil for each group are chosen by the technical department which conducted the approval tests. The helmets of the same batch can be submitted to test up to three different impact point. The location of the points must be the same for all the helmets of the same batch.

9.2.2.3. All the shell sizes of a type of helmet must be submitted to standard linear impact test on the BXP and S points if present.

9.2.2.4. The results of the tests described in paragraphs 9.2.1. and 9.2.2. must comply with the following two conditions:

no value shall exceed 1.1 L, and

$$\bar{X} + 2.4 S \text{ shall not exceed } L$$

where:

L = the limit value prescribed for each approval test

\bar{X} = the mean of the values

S = the standard deviation of the values

The value of 2.4 specified above is only valid for a series of tests applied to at least 10 helmets, tested under the same conditions.

9.2.2.4.1. No Contracting Party applying this Regulation shall apply the criterion

$$\bar{X} + 2.4 S \text{ shall not exceed } L$$

as contained in paragraph 9.2.2.3., to the HIC value as measured in accordance with paragraph 7.3.

9.3. Production qualification of the visors

The production of each new approved type of visor (approved as such or as forming part of the helmet) must be subjected to production qualification tests.

For this purpose, a random sample of 20 visors (30 if the mist-retardant test is involved) will be taken from the first batch.

The first batch is considered to be the production of the first tranche containing a minimum of 200 visors and a maximum of 3,200 visors.

9.3.1. Test group A

light transmission - paragraph 6.15.3.4.
recognition of light signals - paragraph 6.15.3.6.
spectral transmission - paragraph 6.15.3.7.
light diffusion - paragraph 6.15.3.5.
optical qualities and resistance to scratches
- paragraph 7.8.3.

Test group B

refractivity - paragraph 6.15.3.8.
mechanical characteristics - paragraph 7.8.2.

Test group C (optional)

mist-retardant - paragraph 6.15.3.9.

9.3.2. From the 20 visors (30 if the mist-retardant test is involved) take two (or three if the mist-retardant test is involved) groups each of 10 visors.

9.3.3. The first group of 10 visors will be subjected to each of the tests in group A, the second group to each of the tests in group B (and the third group to the test in group C if the mist-retardant test is involved).

9.3.4. The results of the tests described in paragraph 9.3.3. must comply with the values prescribed for each approval test.

9.4 **Product qualification test of sun shield**

9.4.1 Test group A

light transmission - paragraph 6.17.2.4.
recognition of light signals - paragraph 6.17.2.6.
[spectral transmission - paragraph 6.17.2.7.]

Test group B

refractivity - paragraph 6.17.3.8.

9.4.2 From the 20 sun shields take two groups each of 10 sun shields.

9.4.3 The first group of 10 sun shields will be subjected to each of the tests in group A, the second group to each of the tests in group B.

9.4.4 The results of the tests described in paragraph 9.4.3 must comply with the values prescribed for each approval test

10 CONFORMITY OF PRODUCTION AND ROUTINE TESTS

10.4 The helmet or visor approved under this Regulation (whether the visor is approved as such or as forming part of the helmet), having satisfied the acceptability conditions of production qualification, shall be so manufactured as to conform to the type approved by complying with the requirements set out in paragraphs 6. and 7.

10.5 In order to verify that the conditions stated in paragraph 10.1. have been met, appropriate control of the production must be performed.

10.6 The holder of the approval is responsible for the conformity of production procedures and he must in particular:

10.6.1 Ensure the existence of effective procedures so that the quality of the products can be inspected;

10.6.2 Have access to the testing equipment needed to inspect the conformity of each approved type;

10.6.3 Ensure that the test results are recorded and that the annexed documents remain available for a time period of 10 years after test;

10.6.4 Analyse the results of each type of test in order to verify and ensure the stability of the helmet or visor characteristics, making allowances for the variations of industrial production;

10.6.5 Ensure that for each type of helmet or visor at least those tests prescribed in paragraphs 10.5. and 10.6. of the present Regulation are carried out;

10.6.6 Ensure that when any samples or test pieces show non-conformity with the standard test concerned, further samples are taken and tested. All the necessary steps must be taken to restore conformity of the corresponding production.

10.7 The authority which has granted the approval may at any time verify the conformity control methods applied in each production facility.

10.7.1 At every inspection, the test records and production progress records must be available to the visiting inspector.

10.7.2 The inspector may select samples at random to be tested in the manufacturer's test laboratory (in the case where the manufacturer has such a laboratory). The minimum number of samples may be determined according to the results of the manufacturer's own verification.

- 10.7.3 When the level of control appears unsatisfactory, or when it seems necessary to check the validity of the tests carried out in application of paragraph 10.4.2., the inspector must select samples which will be sent to the technical service which conducted the approval tests.
- 10.7.4 The relevant authorities may carry out all of the tests prescribed in the present Regulation.
- 10.7.5 The relevant authorities must conduct inspections in accordance with annex 12. In cases where unsatisfactory results ^{7/} are found during an inspection, the approval authority must ensure that all necessary steps are taken to restore conformity of production as rapidly as possible.
- 10.8 Minimum conditions for the control of conformity of helmets
- In agreement with the relevant authorities, the holder of an approval will undertake the control of conformity following the method of batch control (paragraph 10.5.1.) or following the method of continuous control (paragraph 10.5.2.).
- 10.8.1 **Batch control**
- 10.8.1.1 The holder of an approval must divide the helmets into batches which are as uniform as possible in regard to raw materials or intermediate products involved in their manufacture, and in regard to production conditions. The numbers in a batch must not exceed 3,200 units.
- In agreement with the relevant authorities the tests can be carried out by the technical service or by the holder of an approval.
- 10.8.1.2 For each batch, a sample must be taken in accordance with the provisions of paragraph 10.5.1.4. The sample may be taken before the batch is complete provided the sample is taken from a larger sample consisting of not less than 20 per cent of the final batch quantity.
- 10.8.1.3 The size of the helmets and the tests to be conducted are given in paragraph 10.5.1.4.

^{7/} Unsatisfactory results mean values exceeding 1.1 L, where L is the limit value prescribed for each approval test.

10.8.1.4 In order to be accepted, a batch of helmets must satisfy the following conditions:

TESTS TO BE CONDUCTED							
Numbers in the batch	Number of samples/helmet size	Combined number of samples	Shock absorption (para. 7.3.)	Detaching test (para. 7.7.) Retention system (para. 7.6.)	Acceptance criteria	Rejection criteria	Degree of control rigour
0 < N # 500	1 st = 1LS+1SS+2MS 2 nd = 1LS+1SS+2MS	8	1 LS + 2 MS 1 LS + 2 MS	1 on SS* 1 on SS *	0 1	2 2	Normal
500 < N # 3200	1 st = 2LS+1SS+2MS 2 nd = 2LS+1SS+2MS	10	2 LS + 2 MS 2 LS + 2 MS	1 on SS* 1 on SS *	0 1	2 2	Normal
0 < N # 1200	1 st = 3LS+2SS+3MS 2 nd = 3LS+2SS+3MS	16	3 LS + 3 MS 3 LS + 3 MS	2 on SS* 2 on SS *	0 1	2 2	Strengthened
1200 < N # 3200	1 st = 5LS+3SS+5MS 2 nd = 5LS+3SS+5MS	26	5 LS + 5 MS 5 LS + 5 MS	3 on SS* 3 on SS *	0 3	3 4	Strengthened
<p><u>Note</u> : LS signifies = largest size (max. 62) MS signifies = medium size SS signifies = smallest size (min. 50) * = Both tests (para. 7.7. before para. 7.6.) are carried out on the same helmet. The absorption of the shocks is arranged on B,X, P, R, S for the same helmet</p>							

The conditioning and the anvil in the case of the shock absorption tests are chosen by the technical service which carried out the approval tests.

This dual sampling plan functions as follows:

For a normal control, if the first sample does not contain any defective units the batch is accepted without testing a second sample. If it contains two defective units the batch is rejected.

Finally, if it contains one defective unit a second sample is extracted and it is the cumulative number which must satisfy the condition of column 7 of the table above.

There is a change from normal control to strengthened control if, out of 5 consecutive batches, two are rejected. Normal control is resumed if 5 consecutive batches are accepted.

If 2 consecutive batches subjected to the strengthened control are rejected, the provisions of paragraph 12. are applied.

10.8.1.5 The remainder of the tests, not specified in the table above but which have to be conducted in order to obtain approval, must be conducted at least once per year.

- 10.8.1.6 The control of helmet conformity is undertaken starting with the batch manufactured after the first batch which was subjected to production qualification.
- 10.8.1.7 The test results described in paragraph 10.5.1.4. must not exceed L, where L is the limit value prescribed for each approval test.
- 10.8.2 Continuous control
- 10.8.2.1 The holder of an approval shall be obliged to carry continuous quality control on a statistical basis and by sampling. In agreement with the relevant authorities, the tests can be carried out by the technical service or by the holder of an approval.
- 10.8.2.2 The samples must be taken in accordance with the provisions of paragraph 10.5.2.4.
- 10.8.2.3 The helmets size is taken at random and the tests to carry out are described in paragraph 10.5.2.4.
- 10.8.2.4 For the production to be considered conform, the tests of continuous control shall meet the following requirements.

TESTS TO BE CONDUCTED				
Helmets Taken	Shock absorption kerbstone anvil, heat (para. 7.3.)	Shock absorption flat anvil, low temperature (para. 7.3.)	Detaching (para. 7.7.) Retention system (para. 7.6.)	Degree of control rigour
0.8% means one helmet taken from every 125 manufactured	Helmet No. 1	Helmet No. 2	Helmet No. 3*	Normal
1.5% means one helmet taken from every 66 manufactured	Helmet No. 1	Helmet No. 2	Helmet No. 3*	Strengthened
<p><u>Note:</u> * = Both tests (para. 7.7. before para. 7.6.) are carried out on the same helmet. The absorption of the shocks is arranged on B, X, P, R, S for the same helmet.</p>				

This dual sampling plan functions as follows:

Normal control:

If the helmet tested is considered to conform, the production conforms.

If the helmet does not meet the requirements, a second helmet shall be taken.

If the second helmet tested is considered to conform, the production conforms.

If both helmets do not meet the requirements, the production does not conform and helmets which are likely to present the same failure shall be withdrawn.

Strengthened control:

Strengthened control shall replace normal control if, out of 22 helmets tested consecutively, the production has had to be withdrawn twice.

Normal control is resumed if 40 helmets taken consecutively are considered to conform,

If production subjected to the strengthened control has been withdrawn on two consecutive occasions, the provisions of paragraph 12. are applied.

- 10.8.2.5 The remainder of the tests, not set out in the table above but which have to be conducted in order to obtain approval, must be conducted at least once per year.
- 10.8.2.6 The continuous control of helmets is undertaken starting after the production qualification.
- 10.8.2.7 The test results described in paragraph 10.5.2.4. must not exceed L, where L is the limit value prescribed for each approval test.
- 10.9 Minimum conditions for the control of conformity of visors

In agreement with the relevant authorities, the holder of an approval will undertake the control of conformity following the method of batch control (paragraph 10.6.1.) or following the method of continuous control (paragraph 10.6.2.).

10.9.1 Batch control

10.9.1.1 The holder of an approval must divide the visors into batches which are as uniform as possible in regard to raw materials or intermediate products involved in their manufacture, and in regard to production conditions. The numbers in a batch must not exceed 3,200 units. In agreement with the relevant authorities the tests can be carried out by the technical service or by the holder of an approval.

10.9.1.2 For each batch, a sample must be taken in accordance with the provisions of paragraph 10.6.1.3. The sample may be taken before the batch is complete provided the sample is taken from a larger sample consisting of not less than 20 per cent of the final batch quantity.

10.9.1.3 In order to be accepted, a batch of visors must satisfy the following conditions:

			TESTS TO BE CONDUCTED			Acceptance criteria	Rejection criteria	Stringency of inspection
Numbers in the batch	Number of samples	Combined number of samples	Group A	Group B	Group C*			
0 < N # 500	1 st = 4 (5*) 2 nd = 4 (5*)	8	3 3	1 1	1 1	0 1	2 2	Normal
500 < N # 3200	1 st = 5 (6*) 2 nd = 5 (6*)	10	4 4	1 1	1 1	0 1	2 2	Normal
0 < N # 1200	1 st = 8 (10*) 2 nd = 8 (10*)	16	6 6	2 2	2 2	0 1	2 2	Strengthened
1200 < N # 3200	1 st = 13 (16*) 2 nd = 13 (16*)	26	10 10	3 3	3 3	0 3	3 4	Strengthened
* Additional visor (s) in the case where the visor (s) have been tested in accordance with mist retardant for approval								

Test group A

- Light transmission - para.
- 6.15.3.4. Recognition of light signals -
- para.6.15.3.6. Spectral transmission - para.
- 6.15.3.7.
- Light diffusion - para. 6.15.3.5.
- Optical qualities and
- resistance to scratches - para. 7.8.3.

Test group B

- Refractivity - para.6.15.3.8.
- Mechanical characteristics - para. 7.8.2.

Test group C

- Mist retardant - para. 6.15.3.9.

This dual sampling plan functions as follows:

For a normal control, if the first sample does not contain any defective units the batch is accepted without testing a second sample. If it contains two defective units the batch is rejected.

Finally, if it contains one defective unit a second sample is extracted and it is the cumulative number which must satisfy the condition of column 7 of the table above.

There is a change from normal control to strengthened control if, out of 5 consecutive batches, two are rejected. Normal control is resumed if 5 consecutive batches are accepted.

If 2 consecutive batches subjected to the strengthened control are rejected, the provisions of paragraph 12. are applied.

- 10.9.1.4 The control of visor conformity is undertaken starting with the batch manufactured after the first batch which was subjected to production qualification.
- 10.9.1.5 The test results described in paragraph 10.6.1.3. must not exceed L, where L is the limit value prescribed for each approval test.
- 10.9.2 Continuous control
 - 10.9.2.1 The holder of an approval shall be obliged to carry continuous quality control on a statistical basis and by sampling. In agreement with the relevant authorities, the tests can be carried out by the technical service or by the holder of an approval.
 - 10.9.2.2 The samples must be taken in accordance with the provisions of paragraph 10.6.2.3.
 - 10.9.2.3 For the production to be considered conform, the tests of continuous control shall meet the following requirements:

TESTS TO BE CONDUCTED				
Visors Taken	Group A	Group B	Group C	Stringency of inspection
0.8% means one visor every 125 manufactured	Visor Nos. 1, 2, 3	Visor No. 4	Visor No. 5*	Normal
1.5% means one visor taken every 66 manufactured	Visor Nos. 1, 2, 3	Visor No. 4	Visor No. 5*	Strengthened
Note: Additional visor(s) in the case where the visor(s) have been tested in accordance with mist retardant for approval.				

Test group A

Light transmission - para. 6.15.3.4. Recognition of light signals - para. 6.15.3.6. Spectral transmission - para. 6.15.3.7.
Light diffusion - para. 6.15.3.5.
Optical qualities and resistance to scratches - para. 7.8.3.

Test group B

Refractivity - para. 6.15.3.8.
Mechanical characteristics - para. 7.8.2.

Test group C

Mist retardant - para. 6.15.3.9.

This dual sampling plan functions as follows:

Normal control:

If the visor tested is considered to conform, the production conforms.
If the visor does not meet the requirements, a second visor shall be taken.
If the second visor tested is considered to conform, the production conforms.
If both visors do not meet the requirements, the production does not conform and visors which are likely to present the same failure shall be withdrawn.

Strengthened control:

Strengthened control shall replace normal control if, out of 22 visors tested consecutively, the production has had to be withdrawn twice.
Normal control is resumed if 40 visors taken consecutively are considered to conform.
If production subjected to the strengthened control has been withdrawn on two consecutive occasions, the provisions of paragraph 12. are applied.

10.9.2.4 The continuous control of visors is undertaken starting after the production qualification.

10.9.2.5 The test results described in paragraph 10.6.2.3. must not exceed L, where L is the limit value prescribed for each approval test.

- 11 MODIFICATION AND EXTENSION OF APPROVAL OF A
HELMET OR A VISOR TYPE
- 11.4 Every modification of the helmet and/or the visor type shall be notified to the administrative department which approved the helmet and/or the visor type. The department may then either:
- 11.4.1 Consider that the modifications made are unlikely to have an appreciable adverse effect and that in any case the protective helmet and/or visor still complies with the requirements; or
- 11.4.2 Require a further test report from the technical service responsible for conducting the tests.
- 11.5 Confirmation or refusal of approval, specifying the alterations shall be communicated by the procedure specified in paragraphs 5.1.3. and 5.2.3. above to the Parties to the Agreement applying this Regulation.
- 11.6 The competent authority issuing the extension of approval shall assign a series number for such an extension and inform thereof the other Parties to the 1958 Agreement applying this Regulation by means of a communication form conforming to the model in annex 1A or annex 1B to this Regulation.
- 12 PENALTIES FOR NON-CONFORMITY OF PRODUCTION
- 12.4 The approval granted in respect of a helmet or a visor type pursuant to this Regulation may be withdrawn if the requirements set forth above are not met.
- 12.5 If a Contracting Party to the Agreement applying this Regulation withdraws an approval it has previously granted, it shall forthwith so notify the other Contracting Parties applying this Regulation by means of a communication form conforming to the model in annex 1A or annex 1B to this Regulation.
- 13 PRODUCTION DEFINITELY DISCONTINUED
- If the holder of the approval completely ceases to manufacture a helmet or a visor type approved in accordance with this Regulation, he shall so inform the authority which granted the approval.
- Upon receiving the relevant communication that authority shall inform thereof the other Parties to the 1958 Agreement applying this Regulation by means of a communication form conforming to the model in annex 1A or annex 1B to this Regulation.

14 INFORMATION FOR WEARERS

- 14.4 Every protective helmet placed on the market shall bear a clearly visible label with the following inscription in the national language, or at least one of the national languages of the country of destination.

This information shall contain:

"For adequate protection, this helmet must fit closely and be securely attached. Any helmet that has sustained a violent impact should be replaced"

and, if fitted with a non protective lower face cover:

"Does not protect chin from impacts" together with the symbol indicating the unsuitability of the lower face cover to offer any protection against impacts to the chin.

- 14.5 Additionally where hydrocarbons, cleaning fluids, paints, transfers or other extraneous additions affect the shell material adversely a separate and specific warning shall be emphasized in the above-mentioned label and worded as follows:
- "'Warning' - Do not apply paint, stickers, petrol or other solvents to this helmet".
- 14.6 Every protective helmet shall be clearly marked with its size and its maximum weight, to the nearest 50 grammes, as placed on the market. The maximum weight quoted should include all the accessories that are supplied with the helmets, within the packaging, as it is placed on the market, whether or not those accessories have actually been fitted to the helmet.
- 14.7 Every protective helmet offered for sale shall bear a label showing the type or types of visor that have been approved at the manufacturer's request.
- 14.8 Every visor offered for sale shall bear a label showing the types of protective helmet for which it has been approved.
- 14.9 Every visor placed on the market with a protective helmet shall be accompanied by information in the national language, or in at least one of the national languages, of the country of destination. This information shall contain:
- 14.9.1 General instruction for storage and care.
- 14.9.2 Specific instructions for cleaning and their notice of use. These instructions shall include a warning regarding the dangers of using unsuitable agents for cleaning (such as solvents), especially if abrasion resistant coatings are to be preserved.
- 14.9.3 Advice as to the suitability of the visor for use in conditions of poor visibility and during the hours of darkness. The following warning shall be included:
- 14.9.3.1 Visors with the marking indicating "daytime use only" are not suitable for use during the hours of darkness or in conditions of poor visibility.
- 14.9.4 If appropriate, the following warning shall also be included:
- 14.9.4.1 The fastening of this visor is such that it will not be possible to remove it instantly from the line of sight with one hand should an emergency (such as headlamp glare or misting) occur.

- 14.9.5 If the visor is MIST RETARDANT approved it may be indicated.
- 14.9.6 Instructions regarding the detection of obsolescence.
- 14.10 Every visor placed on the market as a separate technical unit shall be accompanied by information in the national language, or in at least one of the national languages, of the country of destination. This information shall contain advice on the protective helmets for which the visor is suitable and information on those aspects specified in paragraphs 14.6.1. to 14.6.6. where such information is different to that which accompanied the visor that was placed on the market with the protective helmets for which the visor is stated to be suitable.
- 15 TRANSITIONAL PROVISIONS
- 15.4 Helmets and visors
- 15.4.1 As from the official date of entry into force of the 05 series of amendments, no Contracting Party applying this Regulation shall refuse to grant ECE approval under this Regulation as amended by the 05 series of amendments.
- 15.4.2 As from 18 months after the official date of entry into force of the 05 series of amendments, no Contracting Party applying this Regulation shall grant ECE approvals and extension unless the helmet or visor type to be approved meets the requirements of this Regulation as amended by the 05 series of amendments.
- 15.4.3 As from 30 months after the official date of entry into force of the 05 series of amendments, all the Contracting Parties applying this Regulation shall prohibit the application of approval marks on helmets and visors if they refer to type approvals granted under the preceding series of amendments to this Regulation.
- 15.4.4 As from 36 months after the official date of entry into force of the 05 series of amendments, Contracting Parties applying this Regulation may prohibit the sale of helmets and visors which do not meet the requirements of the 05 series of amendments to this Regulation.
- 16 NAMES AND ADDRESSES OF TECHNICAL SERVICES RESPONSIBLE FOR CONDUCTING APPROVAL TESTS, AND OF ADMINISTRATIVE DEPARTMENTS
- The Parties to the 1958 Agreement applying this Regulation shall communicate to the United Nations Secretariat the names and addresses of the technical services responsible for conducting approval tests and of the administrative departments which grant approval and to which forms certifying approval or extension or refusal or withdrawal of approval, or production definitely discontinued, issued in other countries, are to be sent.
-

Annex 1 A

COMMUNICATION

(Maximum format: A4 (210 x 297 mm))



issued by : Name of administration:

concerning: 2/ APPROVAL GRANTED
 APPROVAL EXTENDED
 APPROVAL REFUSED
 APPROVAL WITHDRAWN
 PRODUCTION DEFINITELY DISCONTINUED

of a type of protective helmet without/with 2/ one/more 2/ visor type(s)
 pursuant to Regulation No. 22

Approval No. Extension No.

1. Trade mark:
2. Type:
3. Sizes:
4. Manufacturer's name:
5. Address:
6. If applicable, name of manufacturer's representative:
7. Address:
8. Brief description of helmet:
9. Helmet without lower face cover (J) / with protective lower face cover (P) / with non protective lower face cover (NP) / with detachable or movable lower face cover (P/J) / with detachable or movable non protective lower face cover (NP/J) 2/
10. Type of visor or visors:
11. Brief description of visor or visors:
12. Submitted for approval on:
13. Technical service responsible for conducting approval tests:
14. Date of report issued by that service:
15. Number of report issued by that service:
16. Comments:
17. Approval granted/extended/refused/withdrawn 2/
18. Place:
19. Date:
20. Signature:
21. The following documents, bearing the approval number shown above, are available on request

1/ Distinguishing number of the country which has granted/extended/refused/withdrawn approval (see approval provisions in the Regulation).
2/ Strike out what does not apply.

Annex 1 B

COMMUNICATION

(Maximum format: A4 (210 x 297 mm))



issued by : Name of administration:

concerning: 2/ APPROVAL GRANTED
 APPROVAL EXTENDED
 APPROVAL REFUSED
 APPROVAL WITHDRAWN
 PRODUCTION DEFINITELY DISCONTINUED

of a type of helmet visor pursuant to Regulation No. 22

Approval No. Extension No.

1. Trade mark:
2. Type:
3. Manufacturer's name:
4. Address:
5. If applicable, name of manufacturer's representative:
6. Address:
7. Brief description of visor:
8. Types of helmet to which the visor may be fitted:
9. Submitted for approval on:
10. Technical service responsible for conducting approval tests:
11. Date of report issued by that service:
12. Number of report issued by that service:
13. Remarks:
14. Approval granted/extended/refused/withdrawn 2/
15. Place:
16. Date:
17. Signature:
18. The following documents, bearing the approval number shown above,
 are available on request

1/ Distinguishing number of the country which has granted/extended/
 refused/withdrawn approval (see approval provisions in the Regulation).

2/ Strike out what does not apply.

Annex 2 A

I. PROTECTIVE HELMET

EXAMPLE OF THE ARRANGEMENT OF APPROVAL MARK FOR A PROTECTIVE HELMET
WITHOUT OR WITH ONE OR MORE TYPES OF VISOR

(See paragraph 5.1. of this Regulation)



051406/J-1952 

a = 8 mm min.

The above approval mark affixed to a protective helmet shows that the helmet type concerned has been approved in the Netherlands (E4) under approval number [061406/J](#). The approval number shows that this approval concerns a helmet which does not have a lower face cover (J) and was granted in accordance with the requirements of Regulation No. 22 already incorporating the 06 series of amendments at the time of approval, and that its production serial number is 1952.

Note: The approval number and the production serial number shall be placed close to the circle and either above or below the letter "E" or to the left or right of that letter. The digits of the approval number and of the production serial number shall be on the same side of the letter "E" and face the same direction. The use of Roman numerals as approval numbers should be avoided so as to prevent any confusion with other symbols.

II. VISOR

EXAMPLE OF THE ARRANGEMENT OF APPROVAL MARK FOR A VISOR
FITTED TO A PROTECTIVE HELMET

(See paragraph 5.1. of this Regulation)

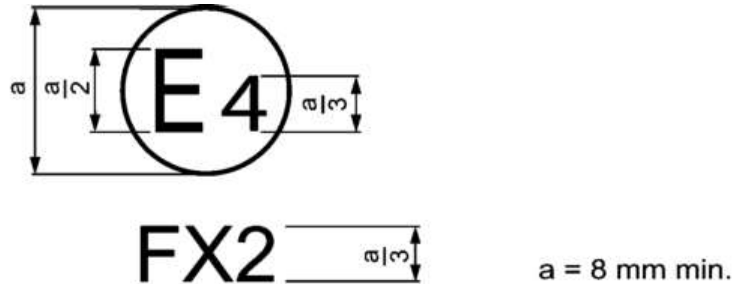

The above approval mark affixed to a visor shows that the visor concerned has been approved in the Netherlands (E4) under reference FX2, and that it forms an integral part of an approved helmet.

Note: The visor reference shall be placed close to the circle and either above or below the letter "E" or to the left or right of that letter. The reference symbols shall face the same direction. The use of numerals alone for the reference should be avoided so as to prevent any confusion with other symbols.

Progressive Number

Annex 2
B

EXAMPLE OF THE ARRANGEMENT OF THE APPROVAL MARK FOR A HELMET VISOR

(See paragraph 5.2.7. of this Regulation)

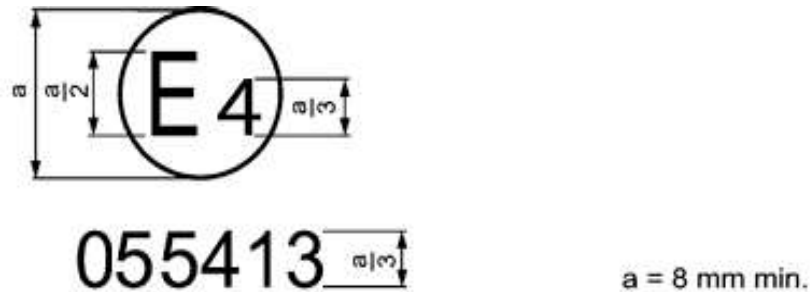

The above approval mark affixed to a visor shows that the visor type concerned has been approved in the Netherlands (E4) under approval number 065413. The approval number shows that approval was granted in accordance with the requirements of the Regulation incorporating the 05 series of amendments at the time of approval.

Note: The approval number shall be placed close to the circle and either above or below the letter "E" or to the left or right of that letter. The digits of the approval number shall be on the same side of the letter "E" and face the same direction. The use of Roman numerals as approval numbers should be avoided so as to prevent any confusion with other symbols.

Progressive Number

Annex 3

DIAGRAM OF PROTECTIVE HELMET

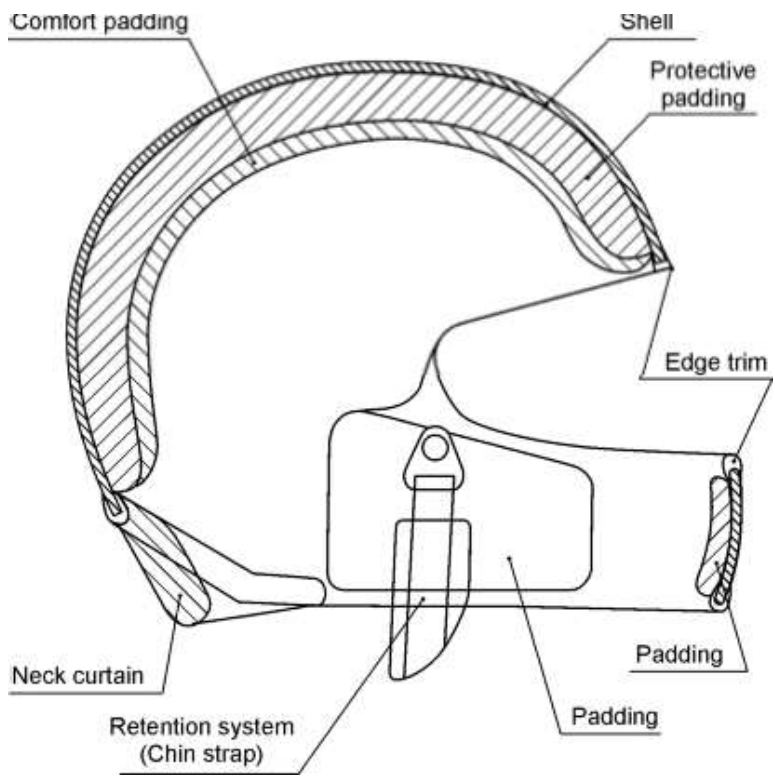

Annex 4

HEADFORMS

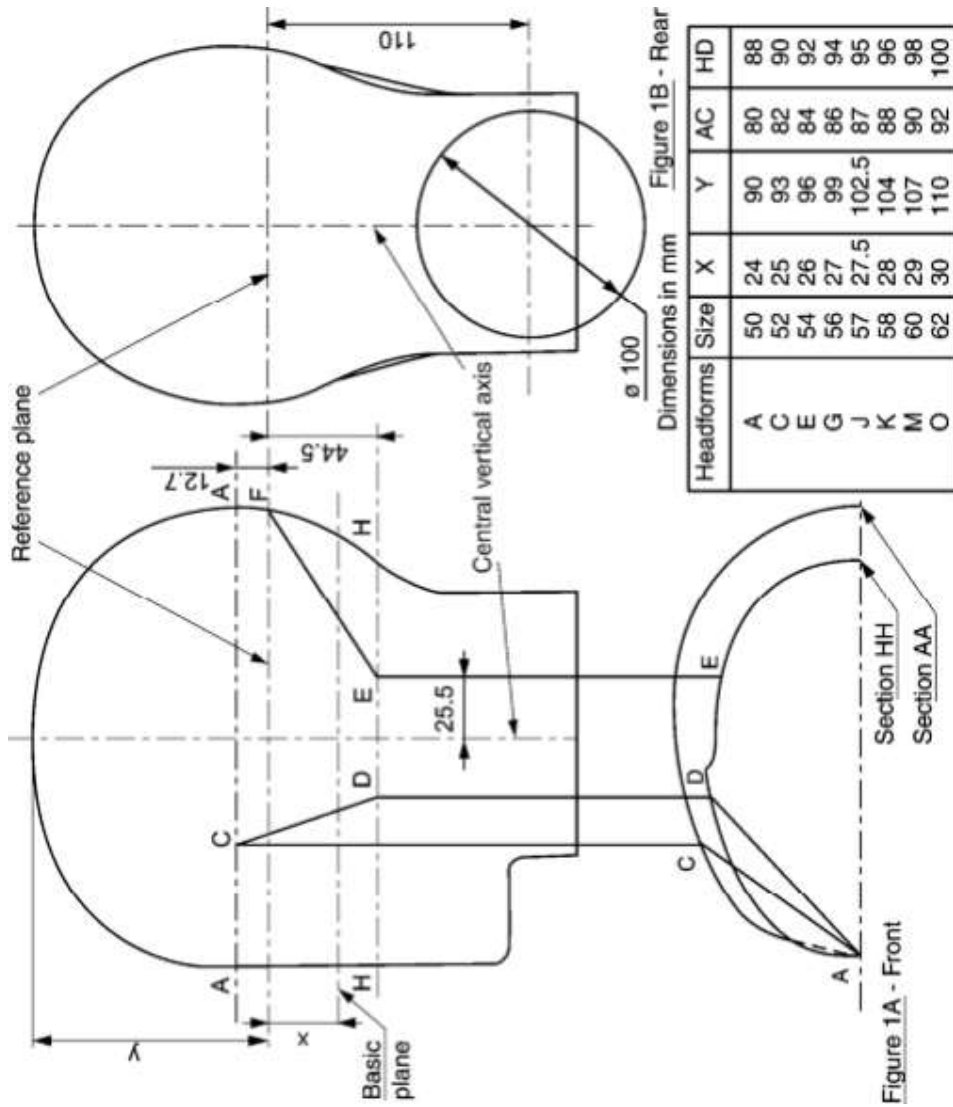

Figure 1 - MINIMUM EXTENT OF PROTECTION

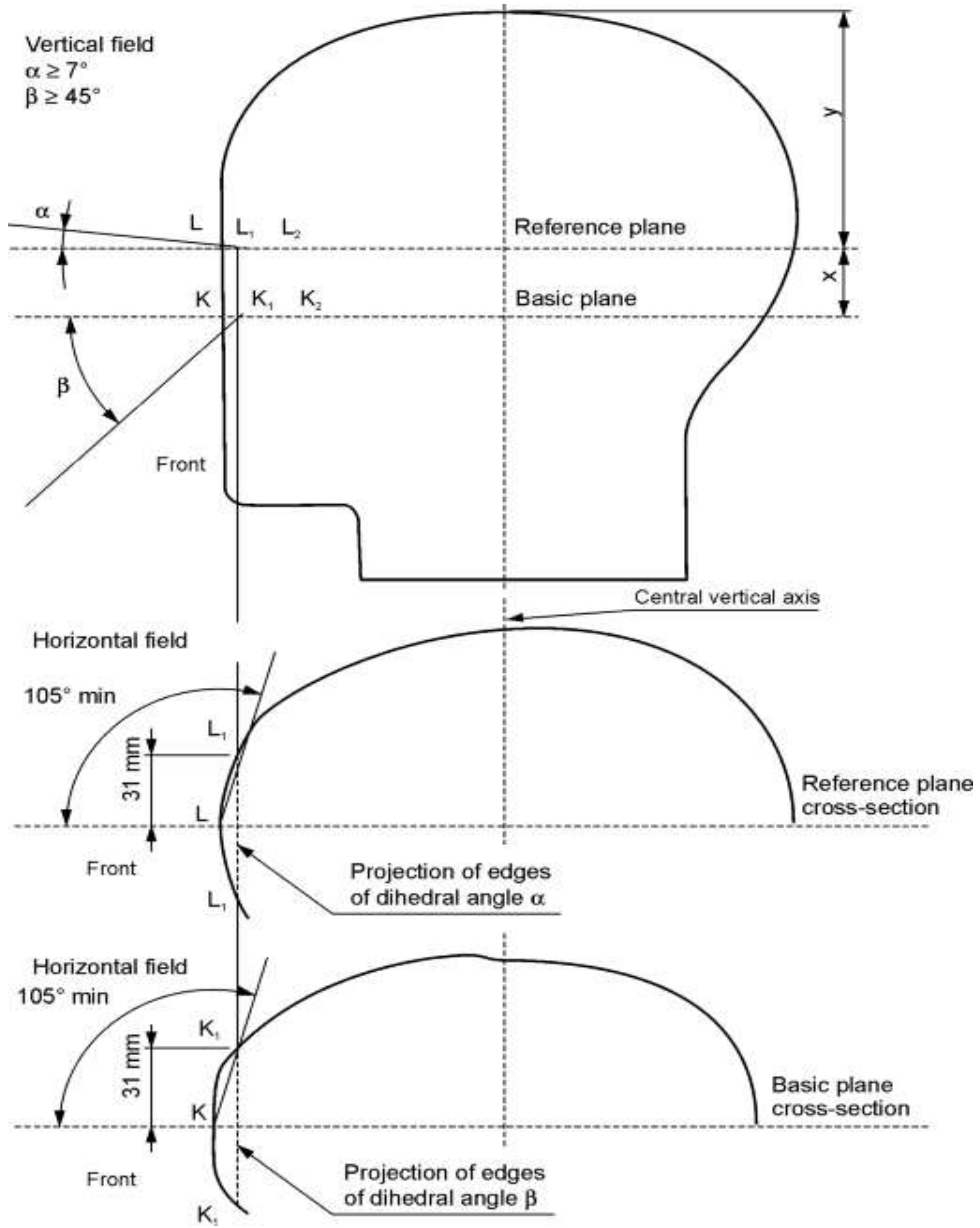

Figure 2A - PERIPHERAL VISION

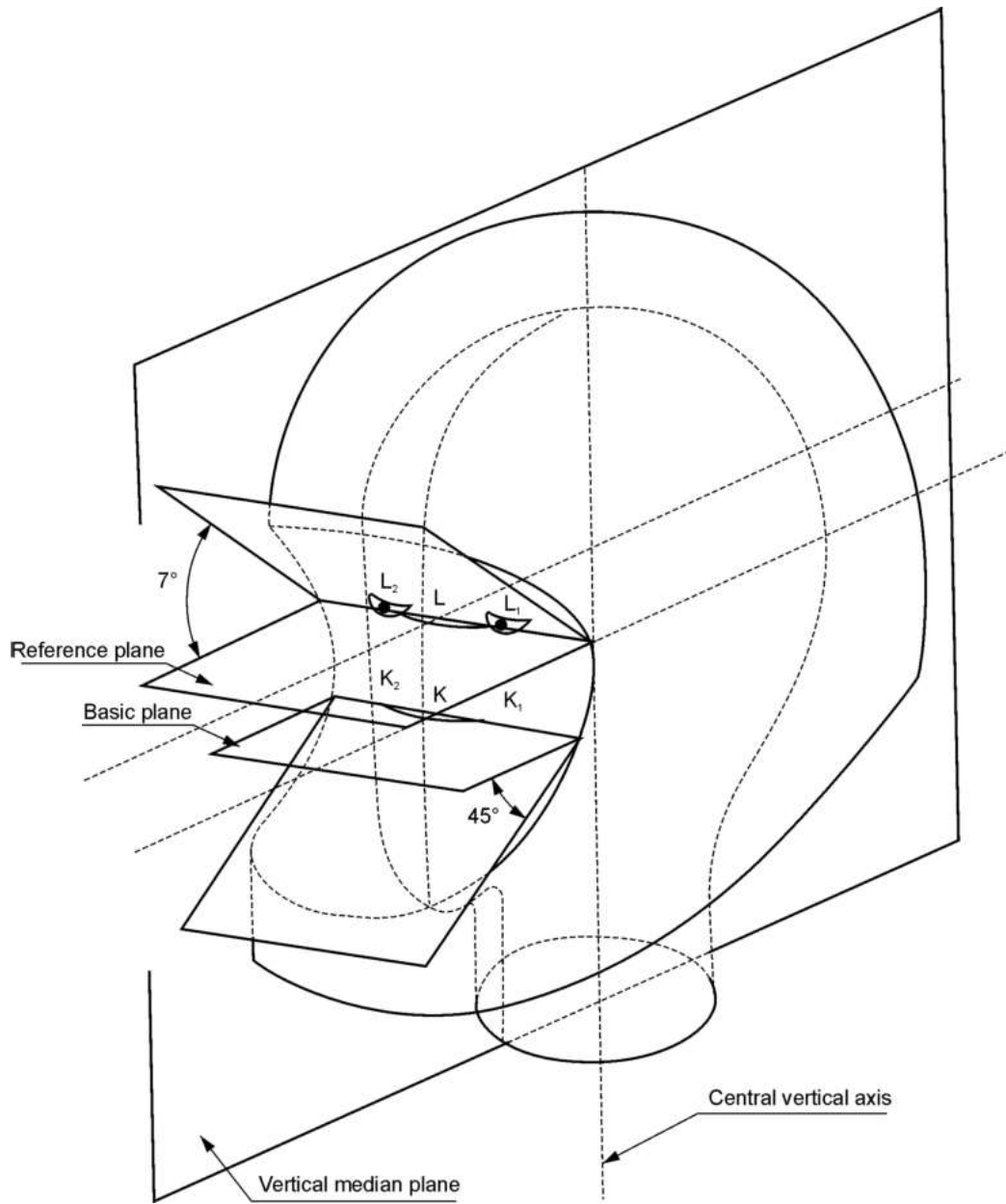

Figure 2B - PERIPHERAL VISION - VERTICAL FIELD

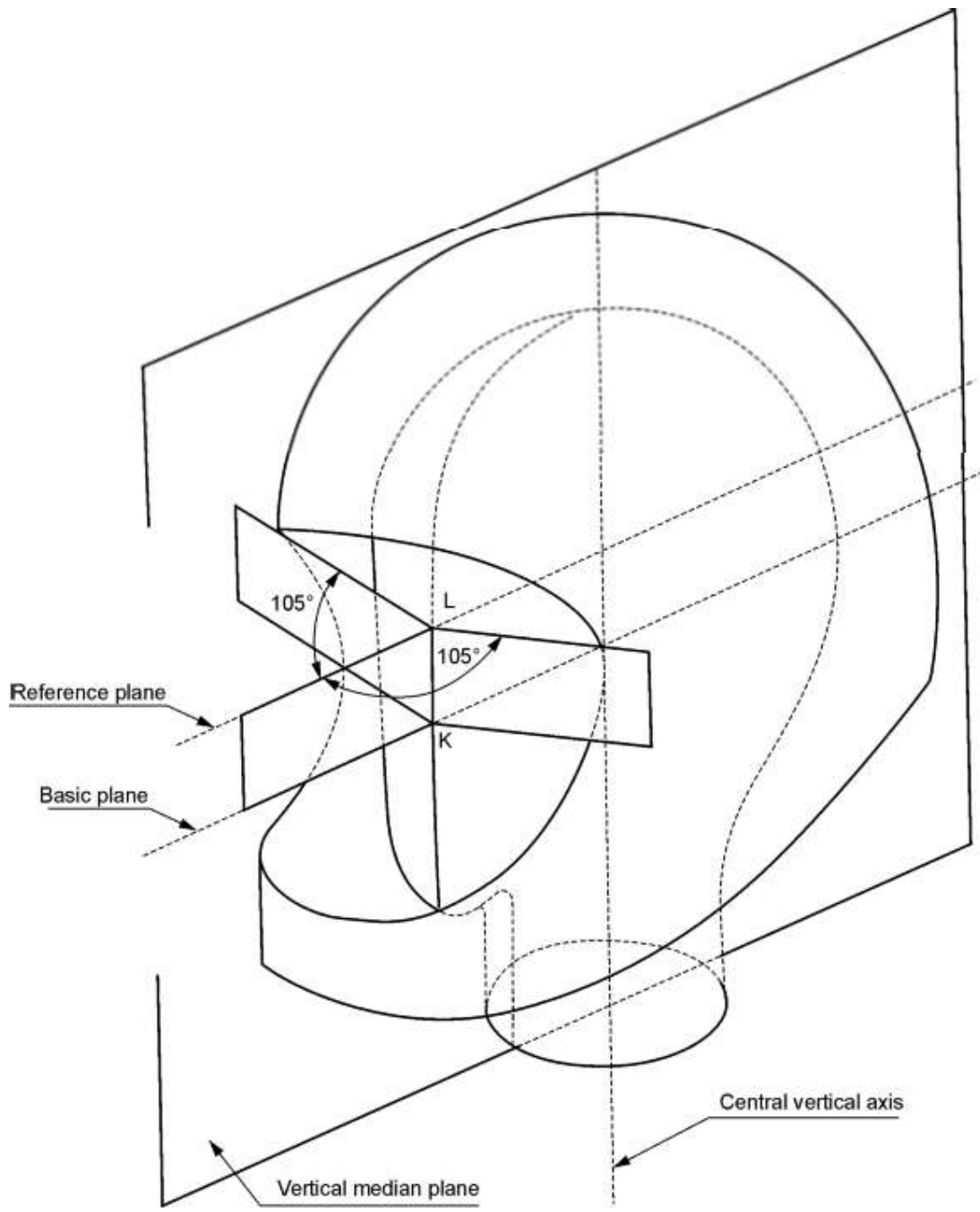

Figure 2C - PERIPHERAL VISION - HORIZONTAL FIELD

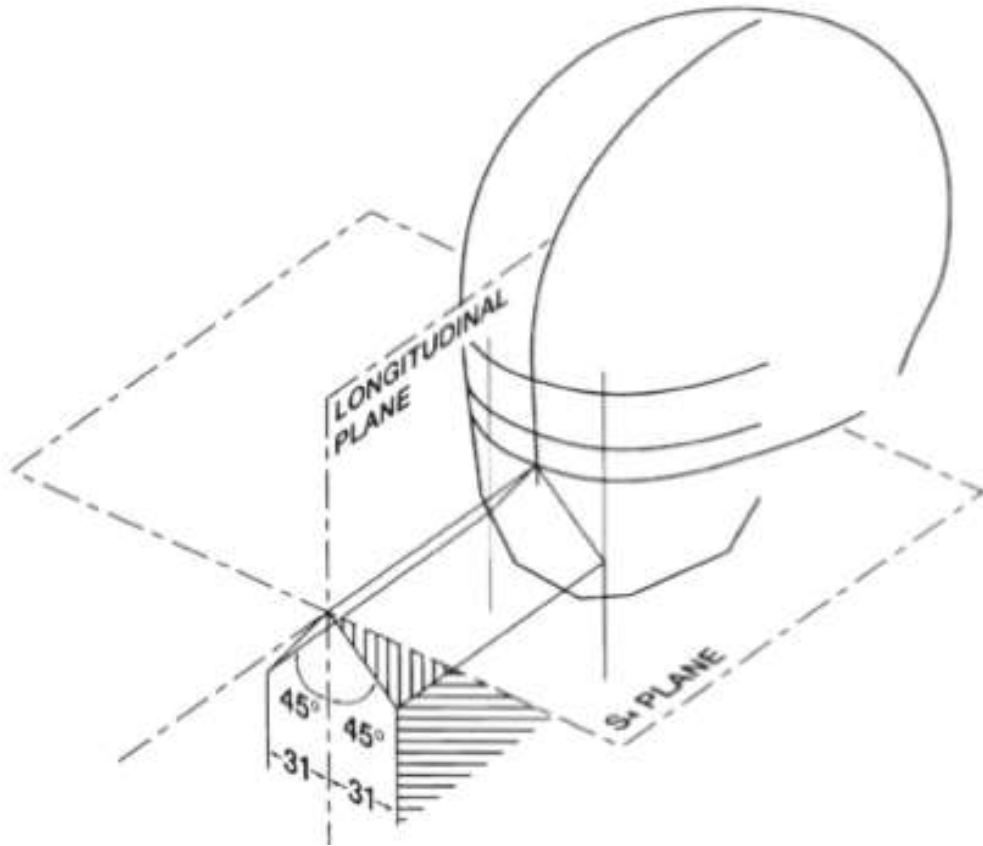

Figure 2D - PERIPHERAL VISION - BREATH DEFLECTOR

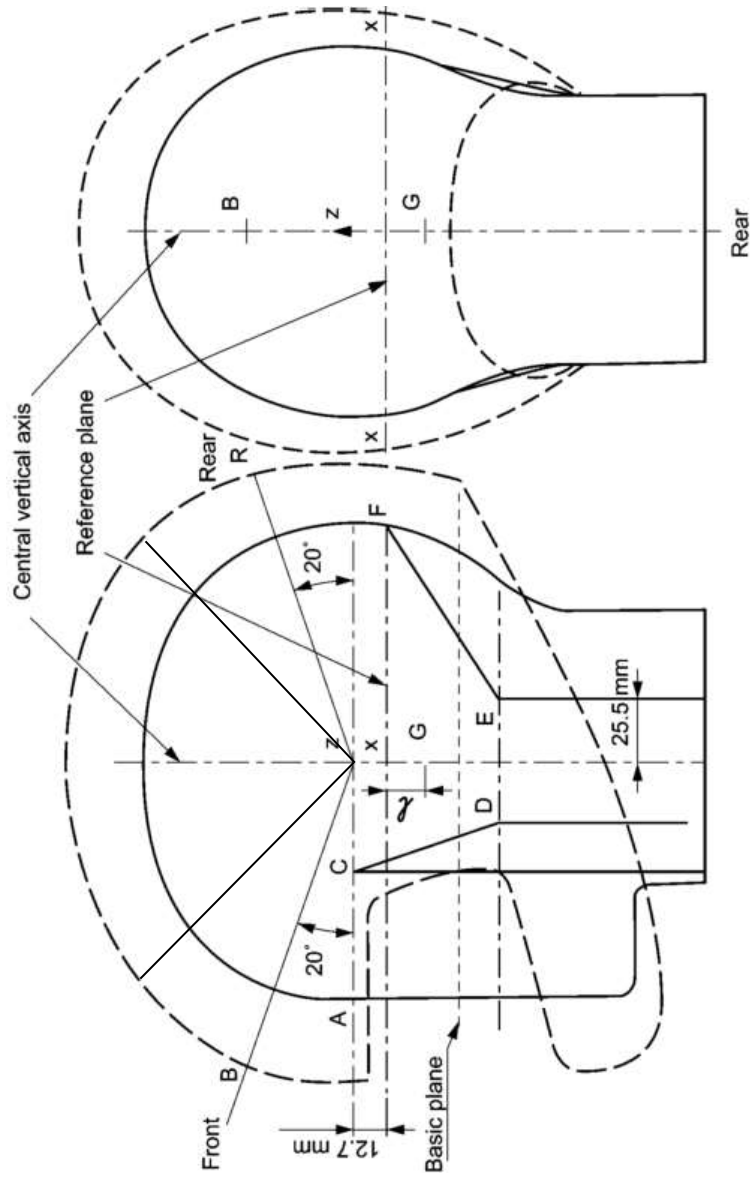

Figure 3 - IDENTIFICATION OF POINTS OF IMPACT

Annex 5

POSITIONING OF THE HELMET ON THE HEADFORM

1. The helmet is placed on a headform of appropriate size. A load of 50 N is applied on the crown of the helmet in order to adjust the helmet on the headform. It is ascertained that the vertical median plane of the helmet coincides with the median vertical plane of the headform.
 2. The front edge of the helmet is placed against a gauge to check the minimum angle for the upward field of vision. The following points are then checked:
 - 2.1. that the line AC and the ACDEF zone are covered by the shell (annex 4, fig. 1);
 - 2.2. that the requirements for the minimum downward angle and the horizontal field of vision are satisfied;
 - 2.3. Requirements of paragraph 6.4.2. of this Regulation relating to the rear projection should be respected.
 3. If one of these conditions is not met, the helmet is moved slightly from front to rear to seek a position where all the requirements are met. Once such a position is determined, a horizontal line is drawn on the shell at the level of the AA' plane. This horizontal line shall determine the reference plane for the positioning of the helmet during the tests.
-

Annex 6

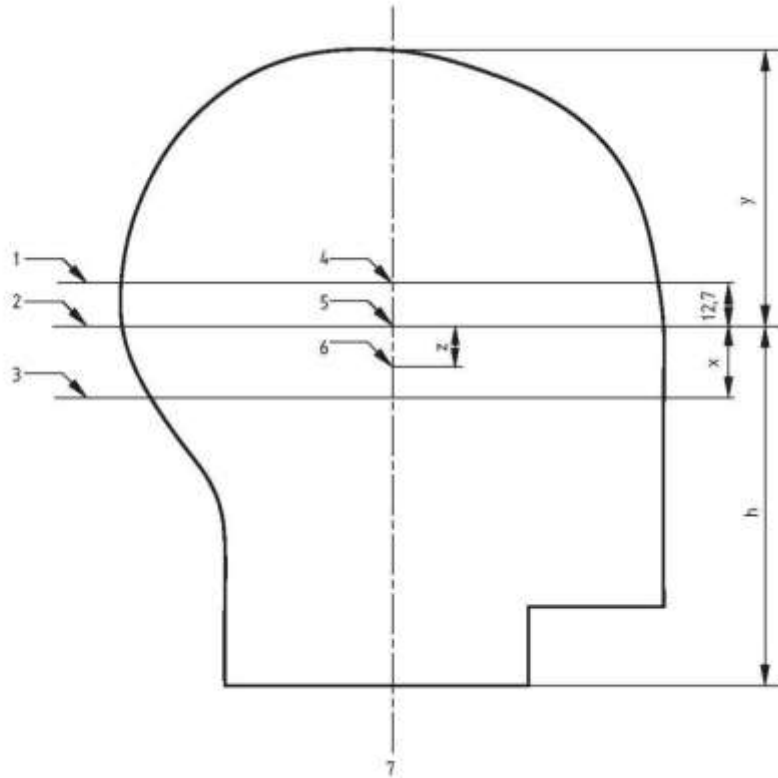

Section on vertical longitudinal plane

Key

- 1 AA' plane
- 2 reference plane
- 3 basic plane
- 4 point A
- 5 point R
- 6 point G
- 7 central vertical axis

Figure 1 — Principal planes and reference points of a headform

Table 1 — Dimensions for Figure 1 and headform masses

Size designation	h (mm)	x (mm)	y (mm)	z (mm)	Mass (g)
445	108,5	21,0	81,7	9,9	
455	110,6	21,5	83,3	10,1	1 970 ± 75
465	112,7	22,0	84,8	10,4	
475	114,8	22,5	86,4	10,6	
485	116,9	23,0	88,0	10,8	
495	119,0	23,5	89,7	11,1	3 100 ± 100
505	121,1	24,0	91,2	11,3	
515	123,2	24,5	92,7	11,5	
525	125,3	25,0	94,5	11,7	
535	127,4	25,5	96,0	11,9	4 100 ± 120
545	129,5	26,0	97,5	12,1	
555	131,6	26,5	99,1	12,3	
565	133,7	27,0	100,8	12,5	
575	135,8	27,5	102,4	12,7	4 700 ± 140
585	137,9	28,0	103,9	12,9	
595	140,0	28,5	105,4	13,1	
605	142,1	29,0	107,2	13,3	5 600 ± 160
615	144,2	29,5	108,7	13,5	
625	146,3	30,0	110,2	13,7	6 100 ± 180
635	148,4	30,5	111,8	13,9	
645	150,5	31,0	113,5	14,1	

Table A.1 — Spherical coordinates for full headform size 445

1 - 445	Angle H														
	0	15	30	45	60	75	90	105	120	135	150	165	180		
90	80,3	80,3	80,3	80,3	80,3	80,3	80,3	80,3	80,3	80,3	80,3	80,3	80,3		
80	79,3	79,1	79,1	79,2	79,4	79,8	79,8	80,1	80,8	81,0	81,6	81,7	81,6		
70	78,9	78,8	78,8	78,8	78,6	78,6	78,7	79,5	80,7	81,9	82,8	83,1	83,0		
60	79,6	79,6	79,6	78,7	77,5	76,7	76,9	78,1	79,8	82,1	83,6	83,8	83,8		
50	80,8	80,7	80,8	78,4	75,7	74,2	74,2	75,9	78,2	81,3	83,7	83,8	83,7		
40	81,3	81,1	81,0	77,1	73,2	71,0	70,9	72,9	75,9	79,7	83,0	83,1	83,1		
30	80,7	80,5	79,8	74,7	69,9	67,4	67,1	69,4	73,1	77,4	81,4	82,0	82,2		
20	79,4	79,0	77,5	71,6	66,3	63,6	63,4	66,0	69,8	74,6	79,3	80,8	81,2		
10	78,5	77,5	75,3	68,8	63,5	60,6	60,5	63,2	66,7	71,7	76,9	79,6	80,1		
Reference plane	79,0	77,4	74,4	67,6	62,4	59,7	59,5	62,0	65,7	70,5	75,3	78,4	79,0		
10	80,2	79,3	75,4	67,7	62,0	59,9	59,9	61,8	64,8	69,2	72,8	75,3	75,7		
20	84,0	85,1	77,3	69,2	62,8	59,8	57,5	59,6	62,2	66,1	69,6	71,8	72,3		
30	91,2	92,5	80,7	71,4	65,9	63,3	57,7	59,1	61,9	65,6	68,8	70,4	69,9		
40	103,1	104,5	88,6	77,8	70,9	65,1	61,7	62,3	64,5	67,3	69,5	70,4	69,6		
46	113,7	115,2	93,9	83,4	76,2	68,8	66,3	66,8	68,4	70,4	71,8	72,6	72,3		
50	110,1	111,2	97,4	87,0	81,2	73,6	70,8	71,5	72,5	74,3	75,2	76,1	76,3		
52	107,2	108,3	97,5	88,6	84,2	76,4	73,5	74,4	75,3	76,9	77,8	78,7	79,2		
55	103,3	104,3	96,2	89,0	84,2	80,2	78,6	79,7	80,5	82,0	82,8	84,0	84,7		
60	97,6	98,4	94,4	86,2	89,5	89,6	90,1	91,5	92,6	94,1	95,0	96,6	97,6		
65	101,7	103,5	100,6	101,9	105,5	105,6	106,8	108,4	109,7	111,6	112,7	114,4	115,3		

V = Vertical angle above or below the reference plane
 H = Angle of vertical slice, measured in horizontal plane, from front of mid-sagittal plane
 The jaw line shall be radiused along its length with a nominal 5 mm radius. The base of the neck shall be squared off perpendicular to the central vertical axis.
 NOTE: The surface corresponding to the radii shown in *italics* lies below the jaw line.
 Angles in degrees, to be measured with an uncertainty of measurement not exceeding $\pm 0,2^\circ$.
 Radii in mm, with a tolerance of $\pm 0,5\%$ and measured with an uncertainty of measurement not exceeding 0,1 mm.

Table A.2 — Spherical coordinates for full headform size 455

1 - 455	Angle H														
	0	15	30	45	60	75	90	105	120	135	150	165	180		
90	82,1	82,1	82,1	82,1	82,1	82,1	82,1	82,1	82,1	82,1	82,1	82,1	82,1		
80	81,1	80,9	80,9	81,0	81,2	81,6	81,6	81,9	82,6	82,8	83,4	83,5	83,5		
70	80,6	80,6	80,6	80,6	80,4	80,3	80,5	81,3	82,5	83,7	84,7	84,9	84,9		
60	81,4	81,4	81,4	80,5	79,2	78,4	78,6	79,9	81,6	83,9	85,5	85,7	85,6		
50	82,6	82,5	82,6	80,1	77,4	75,9	75,9	77,6	80,0	83,1	85,6	85,7	85,6		
40	83,1	83,0	82,8	78,9	74,8	72,6	72,5	74,5	77,6	81,5	84,8	85,0	85,0		
30	82,5	82,3	81,6	76,4	71,5	68,9	68,7	71,0	74,7	79,1	83,2	83,9	84,1		
20	81,2	80,7	79,3	73,3	67,8	65,1	64,9	67,5	71,4	76,2	81,0	82,6	83,0		
10	80,3	79,2	77,0	70,3	64,9	62,0	61,9	64,6	68,2	73,3	78,7	81,3	81,9		
Reference plane	80,7	79,1	76,1	69,1	63,8	61,1	60,9	63,4	67,2	72,1	77,0	80,1	80,7		
10	82,0	81,1	77,1	69,2	63,4	61,2	61,3	63,2	66,2	70,7	74,4	77,0	77,4		
20	85,9	87,0	79,1	70,7	64,3	61,2	58,7	61,0	63,6	67,6	71,1	73,4	73,9		
30	93,2	94,5	82,5	73,0	67,3	64,8	59,0	60,5	63,3	67,1	70,4	72,0	71,4		
40	105,4	106,9	90,6	79,5	72,5	66,6	63,1	63,7	66,0	69,9	71,0	72,0	71,2		
46	116,2	117,8	96,0	85,3	77,9	70,4	67,8	68,3	69,9	72,0	73,5	74,3	74,0		
50	112,6	113,7	99,6	89,0	83,1	75,2	72,4	73,1	74,2	75,9	76,9	77,8	76,0		
52	109,6	110,7	99,7	90,6	86,1	78,1	75,2	76,1	77,0	78,6	79,5	80,5	80,9		
55	105,6	106,6	98,3	91,0	86,1	82,0	80,4	81,5	82,4	83,8	84,6	85,8	86,6		
60	99,8	100,6	96,5	90,2	91,5	91,7	92,1	93,5	94,7	96,2	97,2	98,8	98,8		
65	104,0	105,8	102,9	104,2	107,9	108,0	109,2	110,8	112,2	114,1	115,2	117,0	117,9		

V = Vertical angle above or below the reference plane
 H = Angle of vertical slice, measured in horizontal plane, from front of mid-sagittal plane
 The jaw line shall be radiused along its length with a nominal 5 mm radius. The base of the neck shall be squared off perpendicular to the central vertical axis.

NOTE The surface corresponding to the radii shown in italics lies below the jaw line.

Angles in degrees, to be measured with an uncertainty of measurement not exceeding $\pm 0,2^\circ$.
 Radii in mm, with a tolerance of $\pm 0,5$ % and measured with an uncertainty of measurement not exceeding 0,1 mm.

Table A.3 — Spherical coordinates for full headform size 465

1 - 465	Angle H														
	0	15	30	45	60	75	90	105	120	135	150	165	180		
90	83,9	83,9	83,9	83,9	83,9	83,9	83,9	83,9	83,9	83,9	83,9	83,9	83,9		
80	82,9	82,6	82,6	82,8	83,0	83,3	83,4	83,7	84,4	84,6	85,3	85,3	85,3		
70	82,4	82,3	82,4	82,4	82,2	82,1	82,3	83,0	84,4	85,5	86,6	86,8	86,7		
60	83,2	83,1	83,2	82,3	81,0	80,2	80,4	81,6	83,4	85,8	87,4	87,6	87,5		
50	84,4	84,3	84,4	81,9	79,2	77,6	77,6	79,3	81,7	85,0	87,5	87,5	87,5		
40	84,9	84,8	84,6	80,6	76,5	74,2	74,1	76,2	79,3	83,3	86,7	86,8	86,9		
30	84,3	84,2	83,4	78,1	73,0	70,4	70,2	72,6	76,3	80,9	85,1	85,7	85,9		
20	83,0	82,5	81,0	74,9	69,3	66,5	66,3	69,0	72,9	77,9	82,8	84,4	84,8		
10	82,1	80,9	78,7	71,8	66,3	63,4	63,3	66,1	69,7	75,0	80,4	83,1	83,7		
Reference plane	0	82,5	80,9	77,7	70,7	65,2	62,4	62,2	64,8	68,7	73,7	78,7	81,9	82,5	
10	83,8	82,9	78,8	70,7	64,8	62,5	62,6	64,6	67,7	72,3	76,1	78,7	79,1		
20	87,8	89,0	80,8	72,3	65,7	62,5	60,0	62,3	65,0	69,1	72,7	75,0	75,5		
30	95,3	96,6	84,3	74,6	68,8	66,2	60,3	61,8	64,7	68,5	71,9	73,5	73,0		
40	107,7	109,2	92,6	81,3	74,1	68,0	64,4	65,1	67,4	70,4	72,6	73,6	72,7		
46	118,8	120,4	98,2	87,1	79,6	71,9	69,3	69,8	71,4	73,6	75,1	75,9	75,6		
50	115,1	116,2	101,8	90,9	84,9	76,9	74,0	74,7	75,8	77,6	78,6	79,5	79,8		
52	112,0	113,1	101,9	92,6	88,0	79,8	76,9	77,7	78,7	80,4	81,2	82,3	82,7		
55	107,9	109,0	100,5	93,0	88,0	83,8	82,2	83,3	84,2	85,7	86,5	87,7	88,5		
60	102,0	102,9	98,6	92,2	83,5	83,7	94,1	95,6	96,7	98,3	99,3	100,9	102,0		
65	106,3	108,1	105,1	106,5	110,3	110,3	111,6	113,3	114,7	116,6	117,8	119,6	120,5		

V = Vertical angle above or below the reference plane
 H = Angle of vertical slice, measured in horizontal plane, from front of mid-sagittal plane
 The jaw line shall be radiused along its length with a nominal 5 mm radius. The base of the neck shall be squared off perpendicular to the central vertical axis.
 NOTE: The surface corresponding to the radii shown in *italics* lies below the jaw line.
 Angles in degrees, to be measured with an uncertainty of measurement not exceeding $\pm 0,2^\circ$.
 Radii in mm, with a tolerance of $\pm 0,5$ % and measured with an uncertainty of measurement not exceeding 0,1 mm.

Table A.4 — Spherical coordinates for full headform size 475

1 - 475	Angle H														
	0	15	30	45	60	75	90	105	120	135	150	165	180		
90	85,7	85,7	85,7	85,7	85,7	85,7	85,7	85,7	85,7	85,7	85,7	85,7	85,7		
80	84,7	84,4	84,4	84,6	84,8	85,1	85,2	85,5	86,2	86,5	87,1	87,2	87,2		
70	84,2	84,1	84,1	84,1	83,9	83,9	84,1	84,8	86,2	87,4	88,4	88,6	88,6		
60	85,0	84,9	85,0	84,0	82,7	81,9	82,1	83,4	85,2	87,6	89,2	89,5	89,4		
50	86,2	86,1	86,2	83,7	80,9	79,2	79,2	81,0	83,5	86,8	89,3	89,4	89,4		
40	86,8	86,6	86,5	82,3	78,1	75,8	75,7	77,8	81,0	85,1	88,6	88,7	88,7		
30	86,2	86,0	85,2	79,8	74,6	71,9	71,7	74,1	78,0	82,6	86,9	87,6	87,8		
20	84,8	84,3	82,8	76,5	70,8	67,9	67,7	70,4	74,5	79,6	84,6	86,2	86,6		
10	83,8	82,7	80,4	73,4	67,7	64,7	64,6	67,5	71,2	76,6	82,1	84,9	85,5		
Reference plane	84,3	82,6	79,4	72,2	66,6	63,8	63,5	66,2	70,2	75,2	80,4	83,6	84,3		
10	85,6	84,7	80,5	72,3	66,2	63,9	64,0	66,0	69,1	73,8	77,7	80,4	80,9		
20	89,7	90,9	82,6	73,8	67,1	63,9	61,3	63,7	66,4	70,6	74,3	76,6	77,2		
30	97,3	98,7	86,1	76,2	70,3	67,6	61,6	63,1	66,1	70,0	73,5	75,1	74,6		
40	110,1	111,5	94,5	83,0	75,7	69,5	65,8	66,5	68,9	71,9	74,1	75,2	74,3		
46	121,4	123,0	100,3	89,0	81,3	73,5	70,8	71,3	73,0	75,2	76,7	77,5	77,2		
50	117,5	118,7	104,0	92,9	86,7	78,5	75,5	76,3	77,4	79,3	80,3	81,3	81,5		
52	114,4	115,6	104,1	94,6	89,9	81,5	78,5	79,4	80,4	82,1	83,0	84,0	84,5		
55	110,2	111,3	102,6	95,0	89,9	85,6	83,9	85,0	86,0	87,5	88,3	89,6	90,4		
60	104,2	105,1	100,8	94,1	95,5	95,7	96,2	97,6	98,8	100,4	101,4	103,1	104,1		
65	108,6	110,5	107,4	108,8	112,6	112,7	114,0	115,7	117,1	119,2	120,3	122,1	123,1		

V = Vertical angle above or below the reference plane

H = Angle of vertical slice, measured in horizontal plane, from front of mid-sagittal plane

The jaw line shall be radiused along its length with a nominal 5 mm radius. The base of the neck shall be squared off perpendicular to the central vertical axis.

NOTE

The surface corresponding to the radii shown in *italics* lies below the jaw line.

Angles in degrees, to be measured with an uncertainty of measurement not exceeding $\pm 0,2^\circ$.
Radii in mm, with a tolerance of $\pm 0,5\%$ and measured with an uncertainty of measurement not exceeding 0,1 mm.

The base of the neck shall be squared off perpendicular to the central vertical axis.

Table A.5 — Spherical coordinates for full headform size 485

1 - 485	Angle H														
	0	15	30	45	60	75	90	105	120	135	150	165	180		
90	87,5	87,5	87,5	87,5	87,5	87,5	87,5	87,5	87,5	87,5	87,5	87,5	87,5		
80	86,4	86,2	86,2	86,3	86,5	86,9	87,0	87,3	88,0	88,3	88,9	89,0	89,0		
70	86,0	85,9	85,9	85,9	85,7	85,6	85,8	86,6	88,0	89,2	90,3	90,5	90,5		
60	86,8	86,7	86,8	85,8	84,5	83,6	83,8	85,1	87,0	89,4	91,1	91,3	91,3		
50	88,0	87,9	88,0	85,4	82,6	80,9	80,9	82,7	85,2	88,6	91,2	91,3	91,3		
40	88,6	88,4	88,3	84,1	79,8	77,4	77,3	79,5	82,7	86,9	90,4	90,6	90,6		
30	88,0	87,8	87,0	81,5	76,2	73,4	73,2	75,7	79,6	84,3	88,7	89,4	89,6		
20	86,6	86,0	84,5	78,1	72,3	69,3	69,1	71,9	76,1	81,3	86,4	88,0	88,4		
10	85,6	84,4	82,1	74,9	69,2	66,1	66,0	68,9	72,7	78,2	83,8	86,7	87,2		
Reference plane	86,0	84,4	81,1	73,7	68,1	65,1	64,9	67,6	71,6	76,8	82,1	85,4	86,0		
10	87,4	86,5	82,2	73,8	67,6	65,2	65,3	67,4	70,6	75,4	79,3	82,1	82,6		
20	91,6	92,8	84,3	75,4	68,5	65,2	62,6	65,0	67,8	72,1	75,8	78,2	78,8		
30	99,4	100,8	87,9	77,8	71,8	69,0	62,8	64,4	67,5	71,5	75,0	76,7	76,2		
40	112,4	113,9	96,5	84,8	77,3	71,0	67,2	67,9	70,3	73,4	75,7	76,8	75,9		
46	123,9	125,6	102,4	90,9	83,0	75,0	72,3	72,8	74,5	76,8	78,3	79,2	78,8		
50	120,0	121,2	106,2	94,9	88,5	80,2	77,1	77,9	79,1	81,0	82,0	83,0	83,2		
52	116,8	118,0	106,3	96,6	91,8	83,2	80,2	81,1	82,1	83,8	84,7	85,8	86,3		
55	112,5	113,7	104,8	97,0	91,8	87,4	85,7	86,8	87,8	89,4	90,2	91,5	92,3		
60	106,4	107,3	102,9	96,1	97,6	97,7	98,2	99,7	100,9	102,6	103,6	105,3	106,3		
65	110,9	112,8	109,6	111,1	115,0	115,1	116,4	118,1	119,6	121,7	122,8	124,7	125,7		

V = Vertical angle above or below the reference plane
 H = Angle of vertical slice, measured in horizontal plane, from front of mid-sagittal plane
 The jaw line shall be radiused along its length with a nominal 5 mm radius. The base of the neck shall be squared off perpendicular to the central vertical axis.
 NOTE The surface corresponding to the radii shown in *italics* lies below the jaw line.
 Angles in degrees, to be measured with an uncertainty of measurement not exceeding $\pm 0,2^\circ$
 Radii in mm, with a tolerance of $\pm 0,5$ % and measured with an uncertainty of measurement not exceeding 0,1 mm.

Table A.6 — Spherical coordinates for full headform size 495

1 - 495	Angle H													
	0	15	30	45	60	75	90	105	120	135	150	165	180	
90	89,3	89,3	89,3	89,3	89,3	89,3	89,3	89,3	89,3	89,3	89,3	89,3	89,3	
80	88,2	88,0	88,0	88,1	88,3	88,7	88,8	89,1	89,8	90,1	90,8	90,9	90,8	
70	87,7	87,7	87,7	87,7	87,5	87,4	87,6	88,4	89,8	91,1	92,1	92,4	92,3	
60	88,5	88,5	88,6	87,6	86,2	85,3	85,6	86,9	88,8	91,3	93,0	93,2	93,2	
50	89,8	89,8	89,8	87,2	84,3	82,6	82,6	84,4	87,0	90,4	93,1	93,2	93,2	
40	90,4	90,3	90,1	85,8	81,4	79,0	78,9	81,1	84,4	88,7	92,3	92,4	92,5	
30	89,8	89,6	88,8	83,1	77,8	74,9	74,7	77,2	81,3	86,1	90,5	91,3	91,5	
20	88,4	87,8	86,2	79,7	73,8	70,8	70,6	73,4	77,6	82,9	88,2	89,9	90,3	
10	87,4	86,2	83,8	76,5	70,6	67,4	67,3	70,3	74,2	79,8	85,6	88,5	89,0	
Reference plane	87,8	86,1	82,7	75,2	69,5	66,4	66,2	69,0	73,1	78,4	83,8	87,2	87,8	
10	89,2	88,2	83,9	75,3	69,0	66,6	66,6	68,8	72,0	77,0	81,0	83,8	84,3	
20	93,5	94,7	86,0	77,0	69,9	66,6	63,9	66,3	69,2	73,5	77,4	79,8	80,4	
30	101,4	102,9	89,8	79,4	73,3	70,5	64,1	65,8	68,9	73,0	76,5	78,3	77,7	
40	114,7	116,2	98,5	86,5	78,9	72,4	68,6	69,3	71,8	74,9	77,3	78,4	77,4	
46	126,5	128,2	104,5	92,8	84,8	76,6	73,7	74,3	76,0	78,4	79,9	80,8	80,5	
50	122,5	123,7	108,4	96,8	90,4	81,9	78,7	79,5	80,7	82,6	83,7	84,7	84,9	
52	119,3	120,4	108,5	98,6	93,7	85,0	81,8	82,7	83,8	85,5	86,5	87,6	88,1	
55	114,9	116,0	107,0	99,0	93,7	89,2	87,5	88,6	89,6	91,2	92,1	93,4	94,2	
60	108,6	109,5	105,0	98,1	99,6	99,7	100,2	101,8	103,0	104,7	105,7	107,5	108,5	
65	113,2	115,1	111,9	113,4	117,4	117,5	118,8	120,6	122,1	124,2	125,4	127,3	128,3	

V = Vertical angle above or below the reference plane
 H = Angle of vertical slice, measured in horizontal plane, from front of mid-sagittal plane
 The jaw line shall be radiused along its length with a nominal 5 mm radius. The base of the neck shall be squared off perpendicular to the central vertical axis.
 NOTE The surface corresponding to the radii shown in *italics* lies below the jaw line.
 Angles in degrees, to be measured with an uncertainty of measurement not exceeding $\pm 0,2^\circ$.
 Radii in mm, with a tolerance of $\pm 0,5$ % and measured with an uncertainty of measurement not exceeding 0,1 mm.

Table A.7 — Spherical coordinates for full headform size 505

1 - 505	Angle H														
	0	15	30	45	60	75	90	105	120	135	150	165	180		
90	90,9	90,9	90,9	90,9	90,9	90,9	90,9	90,9	90,9	90,9	90,9	90,9	90,9		
80	89,8	89,6	89,6	89,7	90,0	90,3	90,4	90,8	91,4	91,7	92,4	92,5	92,5		
70	89,3	89,3	89,3	89,3	89,1	89,0	89,2	90,0	91,4	92,7	93,8	94,0	94,0		
60	90,1	90,1	90,1	89,2	87,8	87,0	87,2	88,5	90,4	92,9	94,6	94,9	94,8		
50	91,4	91,4	91,4	88,8	85,9	84,2	84,2	86,0	88,6	92,0	94,7	94,8	94,8		
40	92,0	91,9	91,7	87,4	83,0	80,6	80,5	82,7	86,1	90,3	93,9	94,1	94,1		
30	91,4	91,2	90,4	84,8	79,4	76,6	76,4	78,9	82,9	87,7	92,2	92,9	93,1		
20	90,0	89,4	87,9	81,3	75,5	72,4	72,2	75,0	79,3	84,6	89,8	91,5	91,9		
10	89,0	87,8	85,4	78,1	72,2	69,1	69,0	72,0	75,9	81,4	87,2	90,1	90,7		
Reference plane	89,4	87,7	84,4	76,8	71,1	68,1	67,8	70,5	74,7	80,0	85,4	88,8	89,4		
10	90,9	89,9	85,4	76,7	70,2	67,8	67,9	70,0	73,3	78,3	82,4	85,3	85,8		
20	95,2	96,4	87,6	78,3	71,2	67,8	65,1	67,5	70,4	74,9	78,8	81,3	81,9		
30	103,3	104,7	91,4	80,8	74,6	71,7	65,3	67,0	70,1	74,3	77,9	79,7	79,1		
40	116,8	118,3	100,3	88,1	80,3	73,8	69,8	70,6	73,1	76,3	78,7	79,8	78,8		
46	128,8	130,5	106,4	94,4	86,3	77,9	75,1	75,7	77,4	79,8	81,3	82,3	81,9		
50	124,6	125,6	110,3	98,5	92,0	83,3	80,1	81,0	82,1	84,1	85,2	86,2	86,4		
52	121,3	122,3	110,4	100,3	95,4	86,4	83,3	84,3	85,3	87,1	88,0	89,1	89,6		
55	116,8	117,7	108,9	100,7	95,3	90,8	89,0	90,3	91,2	92,9	93,7	95,0	95,9		
60	110,4	111,1	106,9	99,8	101,3	101,5	102,0	103,6	104,8	106,5	107,6	109,4	110,5		
65	114,9	116,6	113,9	115,3	119,4	119,6	120,9	122,8	124,3	126,4	127,6	129,5	130,6		

V = Vertical angle above or below the reference plane
 H = Angle of vertical slice, measured in horizontal plane, from front of mid-sagittal plane
 The jaw line shall be radiused along its length with a nominal 5 mm radius. The base of the neck shall be squared off perpendicular to the central vertical axis.
 NOTE The surface corresponding to the radii shown in *italics* lies below the jaw line.
 Angles in degrees, to be measured with an uncertainty of measurement not exceeding $\pm 0,2^\circ$
 Radii in mm, with a tolerance of $\pm 0,5$ % and measured with an uncertainty of measurement not exceeding 0,1 mm.

Table A.8 — Spherical coordinates for full headform size 515

1 - 515	Angle H												
	0	15	30	45	60	75	90	105	120	135	150	165	180
90	92,5	92,5	92,5	92,5	92,5	92,5	92,5	92,5	92,5	92,5	92,5	92,5	92,5
80	91,4	91,2	91,2	91,3	91,6	92,0	92,0	92,4	93,1	93,4	94,0	94,1	94,1
70	90,9	90,9	90,9	90,9	90,7	90,6	90,8	91,6	93,0	94,3	95,4	95,6	95,6
60	91,7	91,7	91,7	90,8	89,5	88,6	88,8	90,1	92,0	94,5	96,3	96,5	96,4
50	93,0	93,0	93,0	90,4	87,5	85,8	85,8	87,7	90,3	93,7	96,4	96,4	96,4
40	93,6	93,5	93,3	89,0	84,7	82,3	82,2	84,4	87,7	91,9	95,5	95,7	95,7
30	93,0	92,8	92,0	86,4	81,0	78,2	78,0	80,5	84,6	89,3	93,8	94,5	94,7
20	91,6	91,0	89,5	83,0	77,1	74,1	73,9	76,7	80,9	86,2	91,4	93,1	93,5
10	90,6	89,4	87,1	79,8	73,9	70,8	70,6	73,6	77,5	83,1	88,9	91,7	92,3
Reference plane	91,1	89,4	86,0	78,4	72,7	69,7	69,4	72,1	76,3	81,6	87,0	90,4	91,1
10	92,5	91,5	86,9	78,0	71,4	69,0	69,1	71,2	74,6	79,7	83,9	86,8	87,3
20	96,9	98,1	89,1	79,7	72,4	69,0	66,2	68,7	71,7	76,2	80,2	82,7	83,3
30	105,2	106,6	93,0	82,3	75,9	73,0	66,5	68,2	71,4	75,6	79,3	81,1	80,5
40	118,9	120,4	102,1	89,6	81,7	75,1	71,1	71,8	74,3	77,6	80,0	81,2	80,2
46	131,1	132,8	108,2	96,1	87,8	79,3	76,4	77,1	78,7	81,2	82,8	83,7	83,3
50	126,7	127,6	112,3	100,3	93,6	84,7	81,6	82,4	83,6	85,6	86,7	87,7	87,9
52	123,3	124,1	112,4	102,1	97,1	87,9	84,8	85,8	86,8	88,6	89,6	90,7	91,2
55	118,7	119,5	110,8	102,4	97,0	92,3	90,6	91,9	92,8	94,5	95,3	96,7	97,6
60	112,2	112,7	108,7	101,5	103,0	103,2	103,8	105,5	106,7	108,4	109,4	111,3	112,4
65	116,7	118,1	115,8	117,3	121,4	121,7	123,0	125,0	126,5	128,6	129,8	131,8	132,9

V = Vertical angle above or below the reference plane

H = Angle of vertical slice, measured in horizontal plane, from front of mid-sagittal plane

The jaw line shall be radiussed along its length with a nominal 5 mm radius. The base of the neck shall be squared off perpendicular to the central vertical axis.

NOTE

Angles in degrees, to be measured with an uncertainty of measurement not exceeding $\pm 0,2^\circ$.
Radii in mm, with a tolerance of $\pm 0,5\%$ and measured with an uncertainty of measurement not exceeding 0,1 mm.
The surface corresponding to the radii shown in *italics* lies below the jaw line.

Table A.9 — Spherical coordinates for full headform size 525

1 - 525	Angle H														
	0	15	30	45	60	75	90	105	120	135	150	165	180		
90	94,2	94,2	94,2	94,2	94,2	94,2	94,2	94,2	94,2	94,2	94,2	94,2	94,2		
80	93,0	92,9	92,8	93,0	93,2	93,6	93,6	94,0	94,7	95,0	95,6	95,7	95,7		
70	92,5	92,5	92,5	92,5	92,3	92,2	92,4	93,2	94,6	95,9	97,0	97,3	97,2		
60	93,3	93,3	93,3	92,5	91,1	90,2	90,4	91,7	93,6	96,1	97,9	98,1	98,0		
50	94,6	94,6	94,6	92,1	89,1	87,4	87,5	89,3	91,9	95,3	98,0	98,1	98,0		
40	95,2	95,1	94,9	90,6	86,3	83,9	83,8	86,0	89,4	93,5	97,1	97,3	97,3		
30	94,6	94,4	93,6	88,0	82,7	79,9	79,7	82,2	86,2	91,0	95,4	96,1	96,3		
20	93,2	92,7	91,2	84,6	78,8	75,8	75,6	78,3	82,6	87,9	93,1	94,7	95,1		
10	92,2	91,1	88,8	81,4	75,5	72,4	72,3	75,2	79,2	84,7	90,5	93,3	93,9		
Reference plane	92,7	91,0	87,6	80,1	74,3	71,3	71,0	73,7	77,9	83,2	88,6	92,0	92,7		
10	94,1	93,1	88,4	79,3	72,6	70,2	70,3	72,5	75,9	81,1	85,3	88,3	88,8		
20	98,6	99,8	90,7	81,1	73,7	70,2	67,4	69,9	73,0	77,5	81,6	84,2	84,8		
30	107,0	108,4	94,6	83,7	77,2	74,2	67,6	69,4	72,6	76,9	80,7	82,5	81,9		
40	121,0	122,5	103,8	91,2	83,1	76,4	72,3	73,1	75,6	79,0	81,4	82,6	81,5		
46	133,4	135,1	110,1	97,7	89,3	80,7	77,7	78,4	80,1	82,6	84,2	85,1	84,8		
50	128,8	129,5	114,2	102,0	95,2	86,2	83,0	83,9	85,0	87,1	88,2	89,2	89,4		
52	125,3	126,0	114,3	103,9	98,7	89,4	86,2	87,3	88,3	90,2	91,1	92,2	92,8		
55	120,6	121,2	112,6	104,1	98,6	93,9	92,2	93,5	94,5	96,1	97,0	98,4	99,2		
60	114,0	114,3	110,6	103,2	104,7	105,0	105,6	107,4	108,6	110,3	111,3	113,2	114,3		
65	118,4	119,6	117,8	119,3	123,5	123,8	125,2	127,2	128,7	130,8	132,0	134,1	135,2		

V = Vertical angle above or below the reference plane
 H = Angle of vertical slice, measured in horizontal plane, from front of mid-sagittal plane
 The jaw line shall be radiused along its length with a nominal 5 mm radius. The base of the neck shall be squared off perpendicular to the central vertical axis.

Angles in degrees, to be measured with an uncertainty of measurement not exceeding $\pm 0,2^\circ$.
 Radii in mm, with a tolerance of $\pm 0,5$ % and measured with an uncertainty of measurement not exceeding 0,1 mm.

NOTE The surface corresponding to the radii shown in *italics* lies below the jaw line.

Table A.10 — Spherical coordinates for full headform size 535

1 - 535	Angle H													
	0	15	30	45	60	75	90	105	120	135	150	165	180	
90	95,8	95,8	95,8	95,8	95,8	95,8	95,8	95,8	95,8	95,8	95,8	95,8	95,8	
80	94,6	94,5	94,5	94,6	94,8	95,2	95,2	95,6	96,3	96,6	97,3	97,3	97,4	
70	94,1	94,1	94,1	94,2	94,0	93,9	94,1	94,8	96,2	97,6	98,7	98,9	98,9	
60	94,9	94,9	94,9	94,1	92,7	91,8	92,0	93,3	95,2	97,7	99,5	99,7	99,7	
50	96,2	96,2	96,2	93,7	90,7	89,1	89,1	90,9	93,5	96,9	99,6	99,7	99,6	
40	96,8	96,7	96,5	92,3	87,9	85,5	85,4	87,6	91,0	95,1	98,8	98,9	98,9	
30	96,2	96,0	95,2	89,6	84,3	81,5	81,3	83,8	87,8	92,6	97,0	97,7	97,9	
20	94,8	94,3	92,8	86,2	80,4	77,4	77,2	80,0	84,2	89,5	94,7	96,3	96,7	
10	93,8	92,7	90,4	83,1	77,2	74,1	73,9	76,8	80,8	86,4	92,2	94,9	95,5	
Reference plane	94,3	92,6	89,3	81,7	75,9	72,9	72,6	75,3	79,6	84,9	90,3	93,6	94,3	
10	95,8	94,8	89,9	80,7	73,9	71,4	71,5	73,7	77,2	82,5	86,8	89,8	90,3	
20	100,3	101,5	92,2	82,5	74,9	71,4	68,6	71,1	74,2	78,9	83,0	85,6	86,2	
30	108,9	110,2	96,2	85,1	78,5	75,5	68,8	70,6	73,9	78,3	82,1	84,0	83,3	
40	123,1	124,6	105,6	92,7	84,6	77,7	73,5	74,4	76,9	80,3	82,8	84,0	82,9	
46	135,7	137,4	112,0	99,4	90,9	82,1	79,0	79,8	81,5	84,0	85,6	86,6	86,2	
50	130,9	131,4	116,2	103,8	96,8	87,6	84,4	85,4	86,5	88,6	89,6	90,7	91,0	
52	127,3	127,8	116,2	105,7	100,4	90,9	87,7	88,8	89,8	91,7	92,6	93,8	94,3	
55	122,5	123,0	114,5	105,8	100,3	95,5	93,8	95,2	96,1	97,8	98,6	100,0	100,9	
60	115,8	116,0	112,4	104,8	106,4	106,8	107,4	109,2	110,4	112,2	113,2	115,1	116,3	
65	120,2	121,0	119,8	121,3	125,5	125,9	127,3	129,5	130,9	133,1	134,2	136,3	137,5	

V = Vertical angle above or below the reference plane
 H = Angle of vertical slice, measured in horizontal plane, from front of mid-sagittal plane
 The jaw line shall be radiused along its length with a nominal 5 mm radius. The base of the neck shall be squared off perpendicular to the central vertical axis.

NOTE The surface corresponding to the radii shown in *italics* lies below the jaw line.

Angles in degrees, to be measured with an uncertainty of measurement not exceeding $\pm 0,2^\circ$.
 Radii in mm, with a tolerance of $\pm 0,5$ % and measured with an uncertainty of measurement not exceeding 0,1 mm.

Table A.11 — Spherical coordinates for full headform size 545

1 - 545	Angle H													
	0	15	30	45	60	75	90	105	120	135	150	165	180	
90	97,4	97,4	97,4	97,4	97,4	97,4	97,4	97,4	97,4	97,4	97,4	97,4	97,4	
80	96,2	96,1	96,1	96,2	96,5	96,8	96,9	97,2	97,9	98,2	98,9	98,9	99,0	
70	95,7	95,7	95,7	95,8	95,6	95,5	95,7	96,4	97,8	99,2	100,3	100,5	100,5	
60	96,5	96,5	96,5	95,7	94,3	93,4	93,7	94,9	96,8	99,4	101,2	101,4	101,3	
50	97,8	97,8	97,8	95,3	92,3	90,7	90,7	92,5	95,1	98,5	101,2	101,3	101,3	
40	98,4	98,3	98,1	93,9	89,5	87,2	87,1	89,2	92,6	96,8	100,4	100,5	100,6	
30	97,8	97,6	96,8	91,2	85,9	83,2	83,0	85,5	89,5	94,2	98,6	99,3	99,6	
20	96,4	95,9	94,4	87,9	82,1	79,1	78,9	81,6	85,8	91,2	96,4	97,9	98,3	
10	95,4	94,3	92,1	84,7	78,8	75,8	75,6	78,5	82,5	88,0	93,8	96,5	97,1	
Reference plane	95,9	94,3	90,9	83,3	77,5	74,5	74,2	76,9	81,2	86,5	91,9	95,2	95,9	
10	97,4	96,4	91,4	82,0	75,1	72,6	72,7	74,9	78,5	83,9	88,3	91,3	91,9	
20	102,1	103,2	93,8	83,9	76,2	72,6	69,8	72,3	75,5	80,2	84,3	87,1	87,7	
30	110,8	112,1	97,8	86,5	79,8	76,7	70,0	71,8	75,1	79,6	83,5	85,4	84,7	
40	125,2	126,7	107,4	94,3	86,0	79,0	74,7	75,6	78,2	81,7	84,2	85,4	84,3	
46	138,1	139,7	113,9	101,1	92,4	83,5	80,4	81,2	82,8	85,4	87,1	88,0	87,6	
50	132,9	133,4	118,1	105,5	98,5	89,1	85,8	86,8	87,9	90,0	91,1	92,2	92,5	
52	129,3	129,7	118,2	107,5	102,1	92,4	89,2	90,4	91,3	93,2	94,2	95,4	95,9	
55	124,5	124,7	116,4	107,5	102,0	97,0	95,3	96,8	97,7	99,4	100,2	101,7	102,6	
60	117,6	117,6	114,2	106,5	108,1	108,5	109,2	111,1	112,3	114,0	115,0	117,0	118,2	
65	121,9	122,5	121,7	123,3	127,6	128,0	129,4	131,7	133,1	135,3	136,5	138,6	139,7	

V = Vertical angle above or below the reference plane
 H = Angle of vertical slice, measured in horizontal plane, from front of mid-sagittal plane
 The jaw line shall be radiused along its length with a nominal 5 mm radius. The base of the neck shall be squared off perpendicular to the central vertical axis.
 NOTE The surface corresponding to the radii shown in *italics* lies below the jaw line.
 Angles in degrees, to be measured with an uncertainty of measurement not exceeding $\pm 0,2^\circ$.
 Radii in mm, with a tolerance of $\pm 0,5$ % and measured with an uncertainty of measurement not exceeding 0,1 mm.

Table A.12 — Spherical coordinates for full headform size 555

1 - 555	Angle H												
	0	15	30	45	60	75	90	105	120	135	150	165	180
90	99,0	99,0	99,0	99,0	99,0	99,0	99,0	99,0	99,0	99,0	99,0	99,0	99,0
80	97,8	97,7	97,7	97,8	98,1	98,4	98,5	98,8	99,5	99,9	100,5	100,6	100,7
70	97,3	97,3	97,3	97,4	97,2	97,1	97,3	98,0	99,4	100,8	101,9	102,1	102,1
60	98,1	98,1	98,1	97,3	95,9	95,1	95,3	96,5	98,4	101,0	102,8	103,0	102,9
50	99,4	99,4	99,4	96,9	94,0	92,3	92,4	94,1	96,8	100,1	102,9	103,0	102,9
40	100,0	99,9	99,7	95,5	91,1	88,8	88,7	90,9	94,3	98,4	102,0	102,2	102,2
30	99,4	99,2	98,4	92,8	87,6	84,8	84,7	87,1	91,1	95,9	100,3	100,9	101,2
20	98,0	97,5	96,1	89,5	83,7	80,7	80,5	83,3	87,5	92,8	98,0	99,5	100,0
10	97,0	95,9	93,7	86,4	80,5	77,5	77,2	80,1	84,1	89,7	95,5	98,1	98,7
Reference plane	0	97,5	92,6	84,9	79,1	76,2	75,9	78,5	82,8	88,1	93,5	96,8	97,5
10	99,1	98,0	92,9	83,4	76,3	73,8	73,9	76,2	79,8	85,3	89,7	92,9	93,4
20	103,8	104,9	95,3	85,3	77,4	73,8	70,9	73,5	76,7	81,5	85,7	88,5	89,2
30	112,6	113,9	99,4	88,0	81,1	77,9	71,1	73,0	76,4	80,9	84,8	86,8	86,1
40	127,3	128,7	109,2	95,8	87,4	80,4	76,0	76,9	79,4	83,0	85,6	86,8	85,7
46	140,4	142,0	115,8	102,7	93,9	84,9	81,7	82,5	84,2	86,8	88,5	89,5	89,0
50	135,0	135,3	120,1	107,2	100,1	90,5	87,2	88,3	89,4	91,5	92,6	93,7	94,0
52	131,4	131,5	120,1	109,2	103,8	93,8	90,7	91,9	92,8	94,8	95,7	96,9	97,5
55	126,4	126,4	118,3	109,2	103,6	98,6	96,9	98,4	99,3	101,0	101,8	103,3	104,3
60	119,4	119,2	116,1	108,2	109,8	110,3	111,0	113,0	114,1	115,9	116,9	118,9	120,1
65	123,7	124,0	123,7	125,2	129,6	130,1	131,5	133,9	135,3	137,5	138,7	140,9	142,0

V = Vertical angle above or below the reference plane
 H = Angle of vertical slice, measured in horizontal plane, from front of mid-sagittal plane
 The jaw line shall be radiused along its length with a nominal 5 mm radius. The base of the neck shall be squared off perpendicular to the central vertical axis.

NOTE The surface corresponding to the radii shown in *italics* lies below the jaw line.

Angles in degrees, to be measured with an uncertainty of measurement not exceeding $\pm 0,2$.
 Radii in mm, with a tolerance of $\pm 0,5$ % and measured with an uncertainty of measurement not exceeding 0,1 mm.

Table A.13 — Spherical coordinates for full headform size 565

1 - 565	Angle H														
	0	15	30	45	60	75	90	105	120	135	150	165	180		
90	100,6	100,6	100,6	100,6	100,6	100,6	100,6	100,6	100,6	100,6	100,6	100,6	100,6		
80	99,4	99,4	99,3	99,4	99,7	100,0	100,1	100,4	101,1	101,5	102,1	102,2	102,3		
70	98,9	98,9	98,9	99,0	98,8	98,7	98,9	99,7	101,0	102,4	103,6	103,8	103,8		
60	98,7	99,7	99,7	99,0	97,6	96,7	96,9	98,1	100,1	102,6	104,4	104,6	104,5		
50	100,9	101,0	101,0	98,5	95,6	93,9	94,0	95,7	98,4	101,7	104,5	104,6	104,5		
40	101,6	101,5	101,3	97,1	92,8	90,4	90,4	92,5	95,9	100,0	103,6	103,8	103,8		
30	101,0	100,9	100,1	94,4	89,2	86,4	86,3	88,7	92,8	97,5	101,9	102,6	102,8		
20	99,7	99,1	97,7	91,1	85,4	82,4	82,2	84,9	89,1	94,5	99,6	101,1	101,6		
10	98,6	97,6	95,4	88,0	82,2	79,1	78,8	81,7	85,8	91,3	97,1	99,7	100,3		
Reference plane	99,2	97,5	94,2	86,5	80,8	77,8	77,5	80,1	84,4	89,7	95,2	98,4	99,2		
10	100,7	99,6	94,4	84,7	77,5	75,0	75,1	77,4	81,0	86,6	91,2	94,4	94,9		
20	105,5	106,6	96,9	86,7	78,7	75,0	72,1	74,7	78,0	82,8	87,1	90,0	90,6		
30	114,5	115,8	101,0	89,4	82,4	79,2	72,3	74,2	77,6	82,2	86,2	88,2	87,5		
40	129,4	130,8	110,9	97,4	88,8	81,7	77,2	78,2	80,7	84,4	87,0	88,2	87,0		
46	142,7	144,3	117,6	104,4	95,5	86,3	83,0	83,9	85,5	88,2	89,9	90,9	90,5		
50	137,1	137,2	122,1	109,0	101,7	91,9	88,7	89,7	90,8	93,0	94,1	95,3	95,5		
52	133,4	133,4	122,0	111,0	105,4	95,3	92,1	93,4	94,3	96,3	97,3	98,5	99,1		
55	128,3	128,2	120,2	110,9	105,3	100,2	98,5	100,0	100,9	102,7	103,5	105,0	106,0		
60	121,2	120,8	117,9	109,9	111,5	112,1	112,8	114,9	116,0	117,8	118,8	120,8	122,1		
65	125,4	125,5	125,7	127,2	131,6	132,2	133,7	136,1	137,5	139,7	140,9	143,1	144,3		

V = Vertical angle above or below the reference plane
 H = Angle of vertical slice, measured in horizontal plane, from front of mid-sagittal plane
 The jaw line shall be radiused along its length with a nominal 5 mm radius. The base of the neck shall be squared off perpendicular to the central vertical axis.

NOTE The surface corresponding to the radii shown in *italics* lies below the jaw line.

Angles in degrees, to be measured with an uncertainty of measurement not exceeding $\pm 0,2^\circ$.
 Radii in mm, with a tolerance of $\pm 0,5$ % and measured with an uncertainty of measurement not exceeding 0,1 mm.

Table A.14 — Spherical coordinates for full headform size 575

1 - 575	Angle H												
	0	15	30	45	60	75	90	105	120	135	150	165	180
90	102,3	102,3	102,3	102,3	102,3	102,3	102,3	102,3	102,3	102,3	102,3	102,3	102,3
80	101,0	101,0	100,9	101,0	101,3	101,6	101,7	102,0	102,7	103,1	103,8	103,8	104,0
70	100,5	100,5	100,5	100,6	100,5	100,3	100,5	101,3	102,6	104,1	105,2	105,4	105,4
60	101,3	101,3	101,3	100,6	99,2	98,3	98,5	99,7	101,7	104,2	106,1	106,3	106,2
50	102,5	102,6	102,5	100,2	97,2	95,6	95,6	97,3	100,0	103,3	106,1	106,2	106,1
40	103,2	103,1	102,9	98,7	94,4	92,1	92,0	94,1	97,6	101,6	105,2	105,4	105,4
30	102,6	102,5	101,7	96,1	90,8	88,1	88,0	90,4	94,4	99,1	103,5	104,2	104,4
20	101,3	100,7	99,3	92,8	87,0	84,1	83,9	86,6	90,8	96,1	101,3	102,7	103,2
10	100,3	99,2	97,0	89,7	83,8	80,8	80,5	83,3	87,5	93,0	98,8	101,3	101,9
Reference plane	100,8	99,2	95,8	88,1	82,4	79,4	79,1	81,7	86,0	91,3	96,8	100,0	100,8
10	102,3	101,3	95,9	86,1	78,8	76,2	76,3	78,6	82,3	88,0	92,6	95,9	96,4
20	107,2	108,2	98,4	88,1	79,9	76,2	73,3	75,9	79,3	84,2	88,5	91,4	92,1
30	116,3	117,6	102,6	90,8	83,7	80,4	73,5	75,4	78,8	83,6	87,6	89,6	88,9
40	131,5	132,9	112,7	98,9	90,3	83,0	78,4	79,4	82,0	85,7	88,4	89,6	88,4
46	145,0	146,6	119,5	106,0	97,0	87,6	84,3	85,2	86,9	89,6	91,3	92,4	91,9
50	139,2	139,2	124,0	110,7	103,3	93,4	90,1	91,2	92,3	94,5	95,6	96,8	97,0
52	135,4	135,2	124,0	112,8	107,1	96,8	93,6	94,9	95,9	97,8	98,8	100,0	100,6
55	130,2	129,9	122,1	112,6	106,9	101,8	100,1	101,7	102,6	104,3	105,1	106,7	107,6
60	123,0	122,4	119,8	111,6	113,2	113,8	114,6	116,7	117,9	119,6	120,7	122,7	124,0
65	127,2	126,9	127,6	129,2	133,7	134,3	135,8	138,3	139,7	141,9	143,1	145,4	146,6

V = Vertical angle above or below the reference plane

H = Angle of vertical slice, measured in horizontal plane, from front of mid-sagittal plane

The jaw line shall be radiused along its length with a nominal 5 mm radius. The base of the neck shall be squared off perpendicular to the central vertical axis.

Angles in degrees, to be measured with an uncertainty of measurement not exceeding $\pm 0,2^\circ$.
Radii in mm, with a tolerance of $\pm 0,5\%$ and measured with an uncertainty of measurement not exceeding 0,1 mm.

NOTE The surface corresponding to the radii shown in *italics* lies below the jaw line.

Table A.15 — Spherical coordinates for full headform size 585

1 - 585	Angle H												
	0	15	30	45	60	75	90	105	120	135	150	165	180
90	103,9	103,9	103,9	103,9	103,9	103,9	103,9	103,9	103,9	103,9	103,9	103,9	103,9
80	102,6	102,6	102,5	102,6	103,0	103,3	103,3	103,6	104,4	104,8	105,4	105,4	105,6
70	102,1	102,0	102,1	102,3	102,1	102,0	102,1	102,9	104,2	105,7	106,8	107,0	107,1
60	102,9	102,9	102,9	102,2	100,8	99,9	100,1	101,4	103,3	105,8	107,7	107,9	107,8
50	104,1	104,2	104,1	101,8	98,8	97,2	97,2	99,0	101,6	104,9	107,7	107,9	107,7
40	104,8	104,8	104,5	100,3	96,0	93,7	93,7	95,8	99,2	103,2	106,8	107,0	107,1
30	104,2	104,1	103,3	97,7	92,5	89,7	89,6	92,0	96,0	100,8	105,1	105,8	106,1
20	102,9	102,3	101,0	94,4	88,7	85,7	85,5	88,2	92,4	97,7	102,9	104,3	104,8
10	101,9	100,8	98,7	91,4	85,5	82,5	82,1	85,0	89,1	94,6	100,4	102,9	103,5
Reference plane	0	102,4	100,8	97,5	89,8	84,0	81,0	83,3	87,6	92,9	98,4	101,6	102,4
10	104,0	102,9	97,4	87,4	80,0	77,3	77,5	79,9	83,6	89,4	94,1	97,4	98,0
20	108,9	109,9	99,9	89,4	81,1	77,4	74,4	77,1	80,5	85,5	89,9	92,8	93,5
30	118,2	119,5	104,2	92,2	85,0	81,7	74,6	76,6	80,1	84,9	89,0	91,0	90,2
40	133,6	135,0	114,5	100,5	91,7	84,3	79,6	80,7	83,3	87,1	89,8	91,0	89,8
46	147,3	148,9	121,4	107,7	98,5	89,0	85,6	86,6	88,2	91,1	92,8	93,8	93,3
50	141,3	141,1	126,0	112,5	104,9	94,8	91,5	92,7	93,7	96,0	97,1	98,3	98,5
52	137,4	137,1	125,9	114,6	108,8	98,3	95,1	96,4	97,4	99,4	100,3	101,6	102,2
55	132,1	131,6	124,0	114,3	108,6	103,3	101,6	103,3	104,2	105,9	106,7	108,3	109,3
60	124,8	124,0	121,6	113,3	115,0	115,6	116,4	118,6	119,7	121,5	122,5	124,6	126,0
65	126,9	128,4	129,6	131,2	135,7	136,4	137,9	140,5	141,9	144,2	145,3	147,6	148,9

V = Vertical angle above or below the reference plane
 H = Angle of vertical slice, measured in horizontal plane, from front of mid-sagittal plane
 The jaw line shall be radiused along its length with a nominal 5 mm radius. The base of the neck shall be squared off perpendicular to the central vertical axis.

NOTE The surface corresponding to the radii shown in *italics* lies below the jaw line.

Angles in degrees, to be measured with an uncertainty of measurement not exceeding $\pm 0,2^\circ$.
 Radii in mm, with a tolerance of $\pm 0,5\%$ and measured with an uncertainty of measurement not exceeding 0,1 mm.

Table A.16 — Spherical coordinates for full headform size 595

1 - 595	Angle H												
	0	15	30	45	60	75	90	105	120	135	150	165	180
90	105,5	105,5	105,5	105,5	105,5	105,5	105,5	105,5	105,5	105,5	105,5	105,5	105,5
80	104,2	104,2	104,2	104,2	104,6	104,9	104,9	105,3	106,0	106,4	107,0	107,0	107,3
70	103,7	103,6	103,7	103,9	103,7	103,6	103,8	104,5	105,8	107,3	108,5	108,6	108,7
60	104,4	104,5	104,5	103,8	102,4	101,5	101,8	103,0	104,9	107,4	109,3	109,5	109,4
50	105,7	105,8	105,7	103,4	100,4	98,8	98,9	100,6	103,3	106,6	109,4	109,5	109,4
40	106,4	106,4	106,1	101,9	97,6	95,3	95,3	97,4	100,8	104,9	108,5	108,7	108,7
30	105,8	105,7	104,9	99,3	94,1	91,4	91,3	93,7	97,7	102,4	106,7	107,4	107,7
20	104,5	103,9	102,6	96,0	90,3	87,4	87,2	89,8	94,1	99,4	104,5	105,9	106,4
10	103,5	102,5	100,3	93,0	87,1	84,1	83,8	86,6	90,8	96,2	102,1	104,5	105,2
Reference plane	104,0	102,4	99,1	91,4	85,6	82,6	82,3	84,9	89,2	94,5	100,1	103,2	104,0
10	105,6	104,5	98,9	88,8	81,2	78,5	78,7	81,1	84,9	90,8	95,6	98,9	99,5
20	110,6	111,6	101,5	90,8	82,4	78,6	75,6	78,3	81,8	86,8	91,3	94,3	95,0
30	120,1	121,3	105,9	93,6	86,3	82,9	75,8	77,8	81,3	86,2	90,4	92,4	91,6
40	135,7	137,1	116,3	102,0	93,1	85,6	80,9	82,0	84,5	88,4	91,2	92,4	91,1
46	149,7	151,1	123,3	109,4	100,1	90,4	87,0	88,0	89,6	92,5	94,2	95,3	94,8
50	143,4	143,0	127,9	114,2	106,6	96,3	92,9	94,1	95,2	97,5	98,6	99,8	100,0
52	139,4	138,9	127,8	116,4	110,5	99,8	96,6	98,0	98,9	100,9	101,9	103,2	103,8
55	134,0	133,4	125,9	116,0	110,2	104,9	103,2	104,9	105,8	107,6	108,4	110,0	111,0
60	126,6	125,7	123,5	115,0	116,7	117,4	118,2	120,5	121,6	123,4	124,4	126,5	127,9
65	130,7	129,9	131,6	133,1	137,8	138,5	140,0	142,8	144,1	146,4	147,6	149,9	151,2

V = Vertical angle above or below the reference plane

H = Angle of vertical slice, measured in horizontal plane,

from front of mid-sagittal plane

The jaw line shall be radiused along its length with a nominal 5 mm radius. The base of the neck shall be squared off perpendicular to the central vertical axis.

NOTE

The surface corresponding to the radii shown in *italics* lies below the jaw line.

Angles in degrees, to be measured with an uncertainty of measurement not exceeding $\pm 0,2^\circ$.

Radii in mm, with a tolerance of $\pm 0,5\%$ and measured with an uncertainty of measurement not exceeding 0,1 mm.

Table A.17 — Spherical coordinates for full headform size 605

1 - 605	Angle H													
	0	15	30	45	60	75	90	105	120	135	150	165	180	
90	107,1	107,1	107,1	107,1	107,1	107,1	107,1	107,1	107,1	107,1	107,1	107,1	107,1	
80	105,8	105,9	105,8	105,9	106,2	106,5	106,5	106,9	107,6	108,0	108,6	108,6	108,9	
70	105,3	105,2	105,3	105,5	105,4	105,2	105,4	106,1	107,4	108,9	110,1	110,3	110,3	
60	106,0	106,0	106,1	105,5	104,1	103,2	103,4	104,6	106,5	109,1	111,0	111,2	111,0	
50	107,3	107,4	107,3	105,0	102,1	100,4	100,5	102,2	104,9	108,2	111,0	111,1	111,0	
40	108,0	108,0	107,7	103,6	99,3	97,0	97,0	99,0	102,5	106,5	110,1	110,3	110,3	
30	107,4	107,3	106,5	100,9	95,7	93,0	93,0	95,3	99,3	104,0	108,4	109,0	109,3	
20	106,1	105,6	104,3	97,7	92,0	89,1	88,9	91,5	95,7	101,0	106,2	107,5	108,0	
10	105,1	104,1	102,0	94,7	88,8	85,8	85,4	88,2	92,4	97,9	103,7	106,1	106,8	
Reference plane	105,6	104,1	100,7	93,0	87,2	84,3	83,9	86,5	90,8	96,1	101,7	104,8	105,6	
10	107,2	106,2	100,4	90,1	82,5	79,7	79,9	82,4	86,2	92,2	97,0	100,4	101,0	
20	112,4	113,3	103,0	92,2	83,6	79,9	76,8	79,5	83,0	88,2	92,7	95,7	96,5	
30	121,9	123,2	107,5	95,1	87,7	84,2	76,9	79,0	82,6	87,5	91,8	93,9	93,0	
40	137,8	139,1	118,0	103,5	94,5	87,0	82,1	83,2	85,8	89,8	92,6	93,8	92,5	
46	152,0	153,4	125,2	111,0	101,6	91,8	88,3	89,3	91,0	93,9	95,6	96,7	96,2	
50	145,5	145,0	129,9	115,9	108,2	97,7	94,3	95,6	96,6	99,0	100,1	101,3	101,5	
52	141,4	140,7	129,8	118,1	112,1	101,2	98,0	99,5	100,4	102,4	103,4	104,7	105,3	
55	136,0	135,1	127,8	117,7	111,9	106,5	104,8	106,6	107,4	109,2	110,0	111,7	112,7	
60	128,4	127,3	125,3	116,6	118,4	119,1	120,0	122,4	123,5	125,3	126,3	128,4	129,8	
65	132,5	131,4	133,5	135,1	139,8	140,6	142,2	145,0	146,3	148,6	149,8	152,2	153,5	

V = Vertical angle above or below the reference plane
 H = Angle of vertical slice, measured in horizontal plane,
 from front of mid-sagittal plane
 The jaw line shall be radially along its length with a nominal 5 mm radius. The base of the neck shall be squared off perpendicular to the central vertical axis.
 NOTE The surface corresponding to the radii shown in *italics* lies below the jaw line.
 Angles in degrees, to be measured with an uncertainty of measurement not exceeding $\pm 0,2^\circ$.
 Radii in mm, with a tolerance of $\pm 0,5\%$ and measured with an uncertainty of measurement not exceeding 0,1 mm.

Table A.18 — Spherical coordinates for full headform size 615

1 - 615	Angle H														
	0	15	30	45	60	75	90	105	120	135	150	165	180		
90	108,8	108,8	108,8	108,8	108,8	108,8	108,8	108,8	108,8	108,8	108,8	108,8	108,8		
80	107,7	107,6	107,6	107,4	107,6	107,8	108,1	108,5	109,3	109,3	108,5	109,2	109,2		
70	106,9	106,8	106,9	107,1	107,0	106,9	107,0	107,7	110,5	110,5	111,3	111,6	111,6		
60	107,6	107,6	107,7	107,1	105,8	104,8	104,9	106,1	110,7	110,7	112,8	112,9	112,8		
50	108,9	109,0	108,9	106,6	103,6	102,0	102,1	103,7	109,8	109,8	112,6	112,7	112,7		
40	109,6	109,6	109,3	105,1	100,8	98,5	98,6	100,6	108,1	108,1	111,5	111,8	111,8		
30	109,0	108,9	108,2	102,6	97,3	94,7	94,7	97,1	105,7	105,7	110,0	110,6	110,9		
20	107,7	107,2	105,9	99,3	93,7	90,8	90,6	93,2	102,7	102,7	108,0	109,3	109,7		
10	106,7	105,7	103,6	96,3	90,4	87,4	86,9	89,7	99,5	99,5	105,2	107,7	108,4		
Reference plane	0	107,3	105,7	102,4	94,6	88,8	85,9	88,2	92,4	97,8	103,5	106,4	107,3		
10	108,9	107,8	101,9	91,5	83,7	80,9	81,1	83,6	87,5	93,6	98,5	101,9	102,5		
20	114,1	115,0	104,6	93,6	84,9	81,1	77,9	80,7	84,3	89,5	94,1	97,2	97,9		
30	123,8	125,0	109,1	96,5	89,0	85,4	78,1	80,2	83,8	88,9	93,2	95,3	94,4		
40	139,9	141,2	119,8	105,1	95,9	88,3	83,3	84,5	87,1	91,1	93,9	95,3	93,9		
46	154,3	155,7	127,0	112,7	103,1	93,2	89,6	90,7	92,3	95,3	97,1	98,2	97,6		
50	147,6	146,9	131,8	117,7	109,8	99,1	95,7	97,1	98,1	100,4	101,6	102,8	103,1		
52	143,4	142,6	131,7	119,9	113,8	102,7	99,5	101,0	101,9	104,0	104,9	106,3	106,9		
55	137,9	136,9	129,7	119,4	113,5	108,0	106,4	108,2	109,0	110,8	111,6	113,3	114,4		
60	130,2	128,9	127,2	118,3	120,1	120,9	121,8	124,2	125,3	127,1	128,1	130,3	131,8		
65	134,2	132,8	135,5	137,1	141,8	142,7	144,3	147,2	148,5	150,8	152,0	154,4	155,8		

V = Vertical angle above or below the reference plane

H = Angle of vertical slice, measured in horizontal plane, from front of mid-sagittal plane

The jaw line shall be radiused along its length with a nominal 5 mm radius. The base of the neck shall be squared off perpendicular to the central vertical axis.

NOTE

Angles in degrees, to be measured with an uncertainty of measurement not exceeding $\pm 0,2^\circ$.
Radii in mm, with a tolerance of $\pm 0,5$ % and measured with an uncertainty of measurement not exceeding 0,1 mm

The surface corresponding to the radii shown in *italics* lies below the jaw line.

Table A.19 — Spherical coordinates for full headform size 625

1 - 625	Angle H												
	0	15	30	45	60	75	90	105	120	135	150	165	180
90	110,4	110,4	110,4	110,4	110,4	110,4	110,4	110,4	110,4	110,4	110,4	110,4	110,4
80	109,0	109,1	109,0	109,1	109,5	109,7	109,8	110,1	110,8	111,3	111,9	111,9	112,2
70	108,5	108,4	108,5	108,8	108,6	108,4	108,6	109,3	110,5	112,2	113,4	113,5	113,6
60	109,2	109,2	109,3	108,7	107,3	106,4	106,6	107,8	109,7	112,3	114,2	114,4	114,3
50	110,5	110,6	110,5	108,3	105,3	103,7	103,8	105,4	108,2	111,4	114,2	114,4	114,2
40	111,1	111,2	110,9	106,8	102,5	100,2	100,2	102,3	105,8	109,7	113,3	113,5	113,5
30	110,7	110,5	109,8	104,1	99,0	96,3	96,3	98,6	102,6	107,3	111,6	112,2	112,5
20	109,3	108,8	107,5	100,9	95,3	92,4	92,2	94,8	99,0	104,3	109,4	110,7	111,3
10	108,3	107,4	105,3	98,0	92,1	89,1	88,7	91,5	95,7	101,2	107,0	109,3	110,0
Reference plane	108,9	107,3	104,0	96,2	90,4	87,5	87,1	89,7	94,0	99,4	104,9	108,0	108,9
10	110,5	109,4	103,5	92,8	84,9	82,1	82,3	84,8	88,8	94,9	99,9	103,4	104,1
20	115,8	116,7	106,1	95,0	86,1	82,3	79,1	81,9	85,6	90,8	95,5	98,6	99,4
30	125,6	126,9	110,7	97,9	90,3	86,7	79,3	81,4	85,1	90,2	94,5	96,7	95,8
40	142,0	143,3	121,6	106,6	97,4	89,6	84,5	85,8	88,4	92,5	95,3	96,7	95,3
46	156,6	158,0	128,9	114,3	104,6	94,6	90,9	92,1	93,7	96,7	98,5	99,6	99,0
50	149,7	148,8	133,8	119,4	111,4	100,6	97,2	98,5	99,5	101,9	103,1	104,3	104,6
52	145,5	144,4	133,7	121,7	115,5	104,2	101,0	102,5	103,4	105,5	106,5	107,9	108,5
55	139,8	138,6	131,6	121,1	115,2	109,6	108,0	109,8	110,7	112,5	113,3	115,0	116,0
60	132,0	130,5	129,0	120,0	121,8	122,7	123,6	126,1	127,2	129,0	130,0	132,2	133,7
65	136,0	134,3	137,5	139,1	143,9	144,8	146,4	149,4	150,7	153,0	154,2	156,7	158,1

V = Vertical angle above or below the reference plane
 H = Angle of vertical slice, measured in horizontal plane, from front of mid-sagittal plane
 The jaw line shall be radiused along its length with a nominal 5 mm radius. The base of the neck shall be squared off perpendicular to the central vertical axis.
 NOTE The surface corresponding to the radii shown in *italics* lies below the jaw line.
 Angles in degrees, to be measured with an uncertainty of measurement not exceeding $\pm 0,2^\circ$.
 Radii in mm, with a tolerance of $\pm 0,5$ % and measured with an uncertainty of measurement not exceeding 0,1 mm.

Table A.20 — Spherical coordinates for full headform size 635

1 - 635	Angle H														
	0	15	30	45	60	75	90	105	120	135	150	165	180		
90	112,0	112,0	112,0	112,0	112,0	112,0	112,0	112,0	112,0	112,0	112,0	112,0	112,0		
80	110,6	110,7	110,6	110,7	111,1	111,3	111,4	111,7	112,4	112,9	113,5	113,5	113,8		
70	110,1	110,0	110,1	110,4	110,2	110,0	110,2	110,9	112,1	113,8	115,0	115,1	115,2		
60	110,8	110,8	110,8	110,3	108,9	108,0	108,2	109,4	111,3	113,9	115,9	116,1	115,9		
50	112,1	112,2	112,1	109,9	106,9	105,3	105,4	107,0	109,8	113,0	115,9	116,0	115,8		
40	112,7	112,8	112,5	108,4	104,1	101,9	101,9	103,9	107,4	111,3	114,9	115,1	115,2		
30	112,3	112,1	111,4	105,7	100,6	98,0	97,9	100,2	104,2	108,9	113,2	113,8	114,2		
20	110,9	110,4	109,2	102,6	96,9	94,1	93,9	96,4	100,6	106,0	111,1	112,3	112,9		
10	109,9	109,0	106,9	99,6	93,7	90,8	90,3	93,1	97,4	102,8	108,7	110,9	111,6		
Reference plane	0	110,5	105,6	97,8	92,1	89,1	88,7	91,3	95,6	101,0	106,6	109,6	110,5		
10	112,2	111,0	105,0	94,1	86,1	83,3	83,5	86,1	90,1	96,3	101,4	104,9	105,6		
20	117,5	118,4	107,7	96,4	87,4	83,5	80,3	83,1	86,8	92,1	96,9	100,1	100,8		
30	127,5	128,7	112,3	99,3	91,6	87,9	80,4	82,6	86,3	91,5	95,9	98,1	97,2		
40	144,1	145,4	123,4	108,2	98,8	90,9	85,8	87,0	89,6	93,9	96,7	98,1	96,6		
46	158,9	160,3	130,8	116,0	106,2	95,9	92,3	93,4	95,0	98,1	99,9	101,1	100,5		
50	151,8	150,8	135,7	121,1	113,1	102,0	98,6	100,0	101,0	103,4	104,5	105,8	106,1		
52	147,5	146,3	135,6	123,5	117,2	105,7	102,5	104,0	104,9	107,1	108,0	109,4	110,0		
55	141,7	140,3	133,5	122,8	116,8	111,2	109,5	111,5	112,3	114,1	114,9	116,6	117,7		
60	133,8	132,1	130,9	121,7	123,5	124,4	125,4	128,0	129,0	130,9	131,9	134,1	135,6		
65	137,7	135,8	139,4	141,1	145,9	146,9	148,5	151,6	152,9	155,3	156,4	158,9	160,4		

V = Vertical angle above or below the reference plane
 H = Angle of vertical slice, measured in horizontal plane, from front of mid-sagittal plane
 The jaw line shall be radiused along its length with a nominal 5 mm radius. The base of the neck shall be squared off perpendicular to the central vertical axis.
 NOTE The surface corresponding to the radii shown in *italics* lies below the jaw line.
 Angles in degrees, to be measured with an uncertainty of measurement not exceeding $\pm 0,2^\circ$.
 Radii in mm, with a tolerance of $\pm 0,5\%$ and measured with an uncertainty of measurement not exceeding 0,1 mm.

Table A.21 — Spherical coordinates for full headform size 645

1 - 645	Angle H														
	0	15	30	45	60	75	90	105	120	135	150	165	180		
90	113,6	113,6	113,6	113,6	113,6	113,6	113,6	113,6	113,6	113,6	113,6	113,6	113,6		
80	112,2	112,4	112,2	112,3	112,7	112,9	113,0	113,3	114,0	114,5	115,1	115,1	115,5		
70	111,7	111,6	111,7	112,0	111,9	111,7	111,8	112,5	113,7	115,4	116,6	116,8	116,9		
60	112,4	112,4	112,4	112,0	110,5	109,7	109,9	111,0	112,9	115,5	117,5	117,7	117,5		
50	113,7	113,8	113,7	111,5	108,5	106,9	107,0	108,6	111,4	114,6	117,5	117,6	117,5		
40	114,3	114,4	114,1	110,0	105,7	103,5	103,5	105,5	109,0	113,0	116,6	116,8	116,8		
30	113,9	113,7	113,0	107,4	102,3	99,6	99,6	101,9	105,9	110,6	114,8	115,5	115,8		
20	112,6	112,0	110,8	104,2	98,6	95,7	95,5	98,1	102,3	107,6	112,7	113,9	114,5		
10	111,5	110,6	108,6	101,3	95,4	92,5	92,0	94,7	99,0	104,5	110,3	112,5	113,2		
Reference plane	112,1	110,6	107,3	99,5	93,7	90,7	90,3	92,9	97,3	102,6	108,2	111,2	112,1		
10	113,8	112,7	106,5	95,5	87,4	84,5	84,8	87,3	91,3	97,7	102,8	106,4	107,1		
20	119,2	120,1	109,2	97,8	88,6	84,7	81,4	84,3	88,1	93,5	98,3	101,5	102,3		
30	129,4	130,6	113,9	100,8	92,9	89,2	81,6	83,8	87,6	92,8	97,3	99,5	98,6		
40	146,3	147,5	125,1	109,7	100,2	92,2	87,0	88,3	90,9	95,2	98,1	99,5	98,0		
46	161,3	162,6	132,7	117,7	107,7	97,3	93,6	94,8	96,4	99,5	101,4	102,5	101,9		
50	153,9	152,7	137,7	122,9	114,7	103,5	100,0	101,4	102,4	104,9	106,0	107,4	107,6		
52	149,5	148,1	137,5	125,3	118,8	107,2	103,9	105,6	106,4	108,6	109,5	111,0	111,6		
55	143,6	142,1	135,4	124,5	118,5	112,8	111,1	113,1	113,9	115,7	116,5	118,3	119,4		
60	135,6	133,8	132,7	123,4	125,2	126,2	127,2	129,9	130,9	132,7	133,7	136,0	137,6		
65	139,5	137,3	141,4	143,0	148,0	149,0	150,7	153,9	155,1	157,5	158,7	161,2	162,7		

V = Vertical angle above or below the reference plane
 H = Angle of vertical slice, measured in horizontal plane, from front of mid-sagittal plane
 The jaw line shall be radiused along its length with a nominal 5mm radius. The base of the neck shall be squared off perpendicular to the central vertical axis.
 NOTE The surface corresponding to the radii shown in *italics* lies below the jaw line.
 Angles in degrees, to be measured with an uncertainty of measurement not exceeding $\pm 0,2^\circ$.
 Radii in mm, with a tolerance of $\pm 0,5\%$ and measured with an uncertainty of measurement not exceeding 0,1 mm.

Table B.1 — At and above the reference plane

Angle V	Angle H	Equation to define radius, R	Angle H	Equation to define radius, R	Angle H	Equation to define radius, R
90	0	$0,1618 \times C + 9,2476$	15	$0,1621 \times C + 9,0804$	30	$0,1619 \times C + 9,1657$
80		$0,1601 \times C + 8,9737$		$0,1625 \times C + 7,5432$		$0,1618 \times C + 7,8886$
70		$0,1596 \times C + 8,7246$		$0,1599 \times C + 8,5075$		$0,1604 \times C + 8,2735$
60		$0,159 \times C + 9,842$		$0,1594 \times C + 9,6073$		$0,1592 \times C + 9,7525$
50		$0,1588 \times C + 11,224$		$0,1605 \times C + 10,314$		$0,159 \times C + 11,123$
40		$0,1594 \times C + 11,516$		$0,1611 \times C + 10,517$		$0,1598 \times C + 11,007$
30		$0,1605 \times C + 10,344$		$0,161 \times C + 9,8855$		$0,1615 \times C + 8,8126$
20		$0,1612 \times C + 8,5764$		$0,1612 \times C + 8,0269$		$0,1638 \times C + 5,1601$
10		$0,1611 \times C + 7,628$		$0,1631 \times C + 5,4231$		$0,1654 \times C + 1,9203$
0		$0,1617 \times C + 7,798$		$0,1635 \times C + 5,1573$		$0,1634 \times C + 1,8631$
90	45	$0,1623 \times C + 8,9458$	60	$0,1618 \times C + 9,2476$	75	$0,1622 \times C + 9,0053$
80		$0,1613 \times C + 8,2707$		$0,1601 \times C + 8,9737$		$0,1626 \times C + 7,8458$
70		$0,1622 \times C + 7,3814$		$0,1596 \times C + 8,7246$		$0,1627 \times C + 6,9241$
60		$0,1626 \times C + 7,0867$		$0,159 \times C + 9,842$		$0,1622 \times C + 5,9273$
50		$0,1621 \times C + 6,9537$		$0,1588 \times C + 11,224$		$0,1618 \times C + 4,1673$
40		$0,1613 \times C + 5,9665$		$0,1594 \times C + 11,516$		$0,1622 \times C + 1,12$
30		$0,1614 \times C + 3,2511$		$0,1605 \times C + 10,344$		$0,1635 \times C - 3,1776$
20		$0,1633 \times C - 1,1348$		$0,1612 \times C + 8,5764$		$0,165 \times C - 7,873$
10		$0,1653 \times C - 5,3465$		$0,1611 \times C + 7,628$		$0,1652 \times C - 11,186$
0		$0,1617 \times C - 4,8316$		$0,1617 \times C + 7,798$		$0,1614 \times C - 10,437$
90	90	$0,162 \times C + 9,1258$	105	$0,1621 \times C + 9,0933$	120	$0,1622 \times C + 9,0046$
80		$0,1614 \times C + 8,89$		$0,1611 \times C + 9,3991$		$0,1614 \times C + 9,9318$
70		$0,1616 \times C + 7,5993$		$0,1607 \times C + 8,8613$		$0,1596 \times C + 10,799$
60		$0,162 \times C + 5,3608$		$0,1607 \times C + 7,3412$		$0,1606 \times C + 9,3142$
50		$0,1629 \times C + 1,9484$		$0,1614 \times C + 4,5341$		$0,1627 \times C + 6,4684$
40		$0,1645 \times C - 2,566$		$0,1628 \times C + 0,5168$		$0,1639 \times C + 3,3165$
30		$0,1661 \times C - 7,5259$		$0,1642 \times C - 4,0372$		$0,1641 \times C + 0,0462$
20		$0,1663 \times C - 11,749$		$0,1644 \times C - 7,974$		$0,1644 \times C - 3,7554$
10		$0,1642 \times C - 13,931$		$0,1625 \times C - 10,108$		$0,1651 \times C - 7,4812$
0		$0,1608 \times C - 13,392$		$0,1595 \times C - 10,002$		$0,1609 \times C - 6,53$
90	135	$0,1622 \times C + 9,0062$	150	$0,1622 \times C + 8,9846$	165	$0,1622 \times C + 9,0255$
80		$0,1629 \times C + 9,4579$		$0,1625 \times C + 10,332$		$0,1615 \times C + 10,924$
70		$0,1623 \times C + 10,728$		$0,1634 \times C + 11,251$		$0,1625 \times C + 11,945$
60		$0,1616 \times C + 11,292$		$0,1634 \times C + 12,112$		$0,1632 \times C + 12,437$
50		$0,1613 \times C + 10,589$		$0,1626 \times C + 12,622$		$0,163 \times C + 12,498$
40		$0,1619 \times C + 8,5291$		$0,1618 \times C + 12,194$		$0,1622 \times C + 12,145$
30		$0,1632 \times C + 5,2993$		$0,162 \times C + 10,352$		$0,1613 \times C + 11,42$
20		$0,1646 \times C + 1,4561$		$0,1636 \times C + 7,1882$		$0,1605 \times C + 10,417$
10		$0,1646 \times C - 1,6885$		$0,1651 \times C + 3,8485$		$0,1601 \times C + 9,2428$
0		$0,1612 \times C - 1,391$		$0,163 \times C + 3,0673$		$0,1601 \times C + 7,9125$
90	180	$0,162 \times C + 9,0821$				
80		$0,1643 \times C + 9,4916$				
70		$0,1634 \times C + 11,462$				
60		$0,1624 \times C + 12,789$				
50		$0,1621 \times C + 12,914$				
40		$0,1622 \times C + 12,172$				
30		$0,1622 \times C + 11,166$				
20		$0,1616 \times C + 10,277$				
10		$0,1611 \times C + 9,3042$				
0		$0,1626 \times C + 7,2304$				

Table B.2 — Below the reference plane

Angle V	Angle H	Equation to define radius, R	Angle H	Equation to define radius, R	Angle H	Equation to define radius, R
10	0	$0,1637 \times C + 8,2044$	15	$0,1624 \times C + 5,7791$	30	$0,1506 \times C + 9,327$
20		$0,1715 \times C + 8,5973$		$0,1628 \times C + 7,6574$		$0,1546 \times C + 9,5021$
30		$0,1861 \times C + 9,3281$		$0,1694 \times C + 10,843$		$0,161 \times C + 10,056$
40		$0,2104 \times C + 10,544$		$0,1846 \times C + 11,485$		$0,1774 \times C + 10,713$
46		$0,232 \times C + 11,629$		$0,2082 \times C + 13,186$		$0,1861 \times C + 11,391$
50		$0,2094 \times C + 18,822$		$0,1934 \times C + 27,957$		$0,1878 \times C + 11,531$
52		$0,2016 \times C + 19,465$		$0,1848 \times C + 28,943$		$0,1935 \times C + 12,717$
55		$0,1918 \times C + 19,923$		$0,1737 \times C + 30,031$		$0,1894 \times C + 13,21$
60		$0,1799 \times C + 19,532$		$0,1617 \times C + 29,455$		$0,1846 \times C + 13,635$
65		$0,1754 \times C + 26,334$		$0,1475 \times C + 42,113$		$0,1967 \times C + 14,539$
10	45	$0,1345 \times C + 8,7337$	60	$0,1226 \times C + 8,2772$	75	$0,1196 \times C + 7,3815$
20		$0,1388 \times C + 8,2511$		$0,1249 \times C + 8,0829$		$0,1209 \times C + 6,7109$
30		$0,1422 \times C + 9,0368$		$0,1309 \times C + 8,4582$		$0,1246 \times C + 8,7895$
40		$0,1546 \times C + 10,016$		$0,1423 \times C + 8,4352$		$0,1321 \times C + 7,0421$
46		$0,1659 \times C + 10,65$		$0,153 \times C + 9,0181$		$0,1384 \times C + 8,0554$
50		$0,1738 \times C + 10,78$		$0,1621 \times C + 10,12$		$0,1441 \times C + 10,522$
52		$0,178 \times C + 10,447$		$0,1675 \times C + 10,799$		$0,1481 \times C + 11,641$
55		$0,1702 \times C + 14,751$		$0,1653 \times C + 11,864$		$0,1571 \times C + 11,423$
60		$0,1685 \times C + 14,694$		$0,1709 \times C + 14,974$		$0,1765 \times C + 12,349$
65		$0,1978 \times C + 15,457$		$0,2039 \times C + 16,436$		$0,2102 \times C + 13,41$
10	90	$0,1207 \times C + 6,9022$	105	$0,1235 \times C + 7,6355$	120	$0,1288 \times C + 8,2718$
20		$0,1169 \times C + 6,043$		$0,1197 \times C + 7,0857$		$0,1261 \times C + 6,7543$
30		$0,1164 \times C + 6,5267$		$0,1203 \times C + 6,2257$		$0,1245 \times C + 7,2591$
40		$0,1226 \times C + 7,9135$		$0,1266 \times C + 6,6266$		$0,1275 \times C + 8,6669$
46		$0,1323 \times C + 8,2525$		$0,1362 \times C + 6,9303$		$0,1357 \times C + 8,8604$
50		$0,1418 \times C + 8,5344$		$0,1461 \times C + 7,2003$		$0,145 \times C + 8,9154$
52		$0,1475 \times C + 8,8007$		$0,1522 \times C + 7,4013$		$0,151 \times C + 9,0252$
55		$0,1576 \times C + 9,4533$		$0,1632 \times C + 7,8381$		$0,162 \times C + 9,4013$
60		$0,1796 \times C + 11,317$		$0,1873 \times C + 9,0425$		$0,1862 \times C + 10,804$
65		$0,2125 \times C + 13,609$		$0,2218 \times C + 10,794$		$0,2203 \times C + 13,024$
10	135	$0,1384 \times C + 8,4499$	150	$0,1458 \times C + 8,8034$	165	$0,151 \times C + 9,0546$
20		$0,1328 \times C + 7,806$		$0,1393 \times C + 8,4301$		$0,1446 \times C + 8,252$
30		$0,1325 \times C + 7,3776$		$0,1384 \times C + 8,0371$		$0,1415 \times C + 8,2475$
40		$0,1353 \times C + 7,9376$		$0,139 \times C + 8,4601$		$0,1408 \times C + 8,6586$
46		$0,1411 \times C + 8,5164$		$0,1429 \times C + 9,1816$		$0,1447 \times C + 9,1792$
50		$0,1485 \times C + 9,1118$		$0,149 \times C + 9,9328$		$0,1512 \times C + 9,83$
52		$0,1536 \times C + 9,5142$		$0,1537 \times C + 10,41$		$0,1561 \times C + 10,288$
55		$0,1635 \times C + 10,286$		$0,1632 \times C + 11,271$		$0,1661 \times C + 11,164$
60		$0,1871 \times C + 12,058$		$0,187 \times C + 13,127$		$0,1906 \times C + 13,106$
65		$0,2221 \times C + 14,23$		$0,222 \times C + 15,467$		$0,2262 \times C + 15,31$
10	180	$0,1523 \times C + 8,8667$				
20		$0,146 \times C + 8,1376$				
30		$0,1391 \times C + 8,8704$				
40		$0,1372 \times C + 9,5115$				
46		$0,1429 \times C + 9,7331$				
50		$0,1512 \times C + 10,064$				
52		$0,157 \times C + 10,35$				
55		$0,1681 \times C + 10,984$				
60		$0,1937 \times C + 12,646$				
65		$0,2292 \times C + 14,831$				

NOTE The equations shown in *italics* define the surface below the jaw line.

Annex 8

TEST MACHINES

HEADFORM - DROP ASSEMBLY

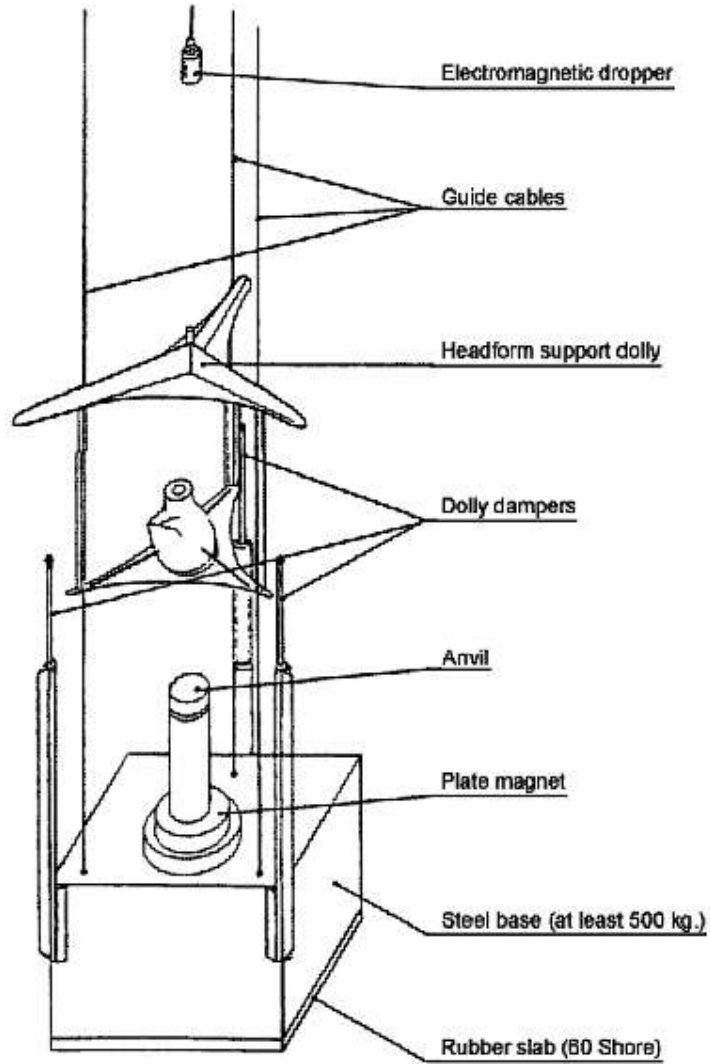

Figure 1a

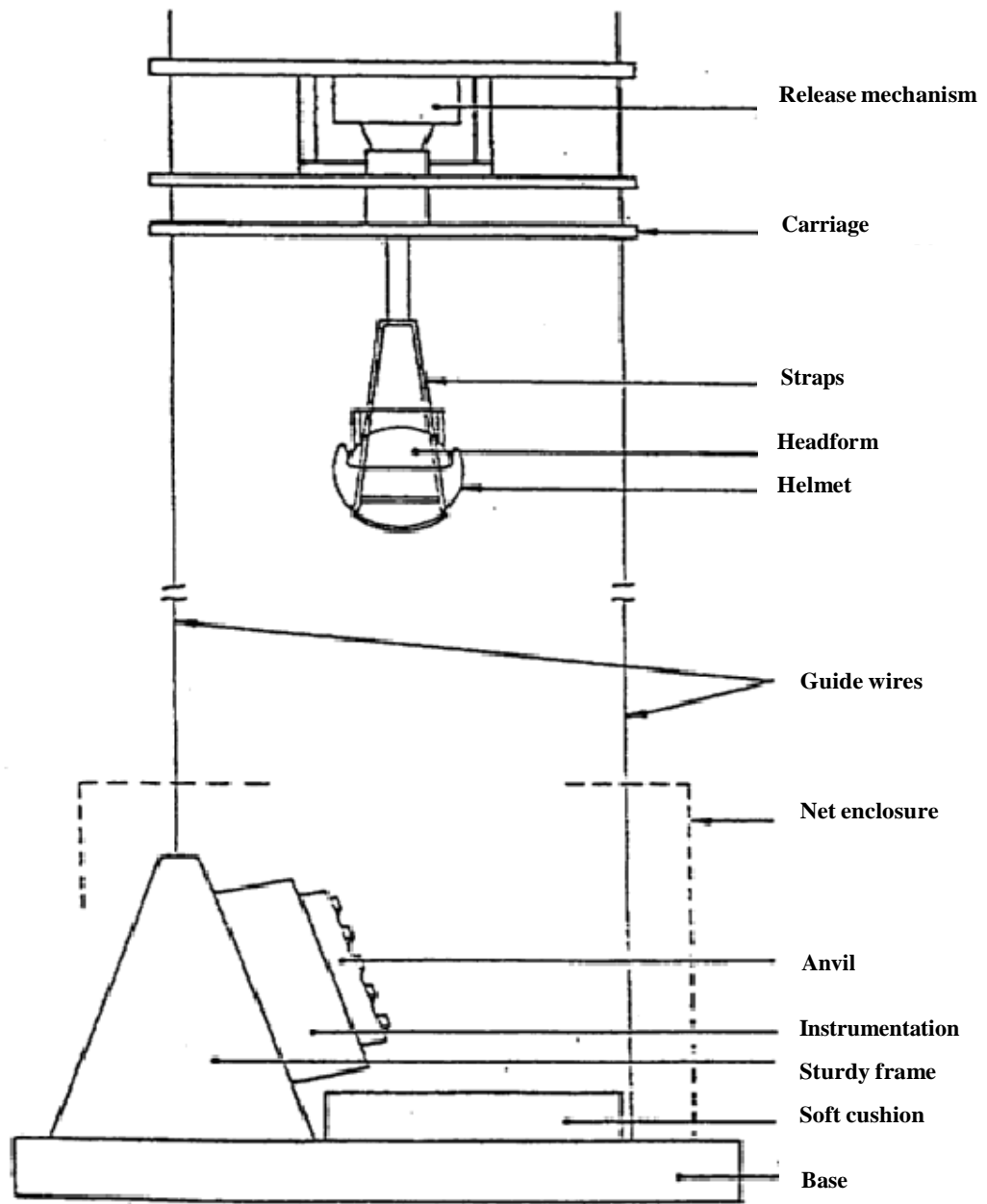

Figure 1b: Example of a suitable test apparatus for projections and surface friction (method A)

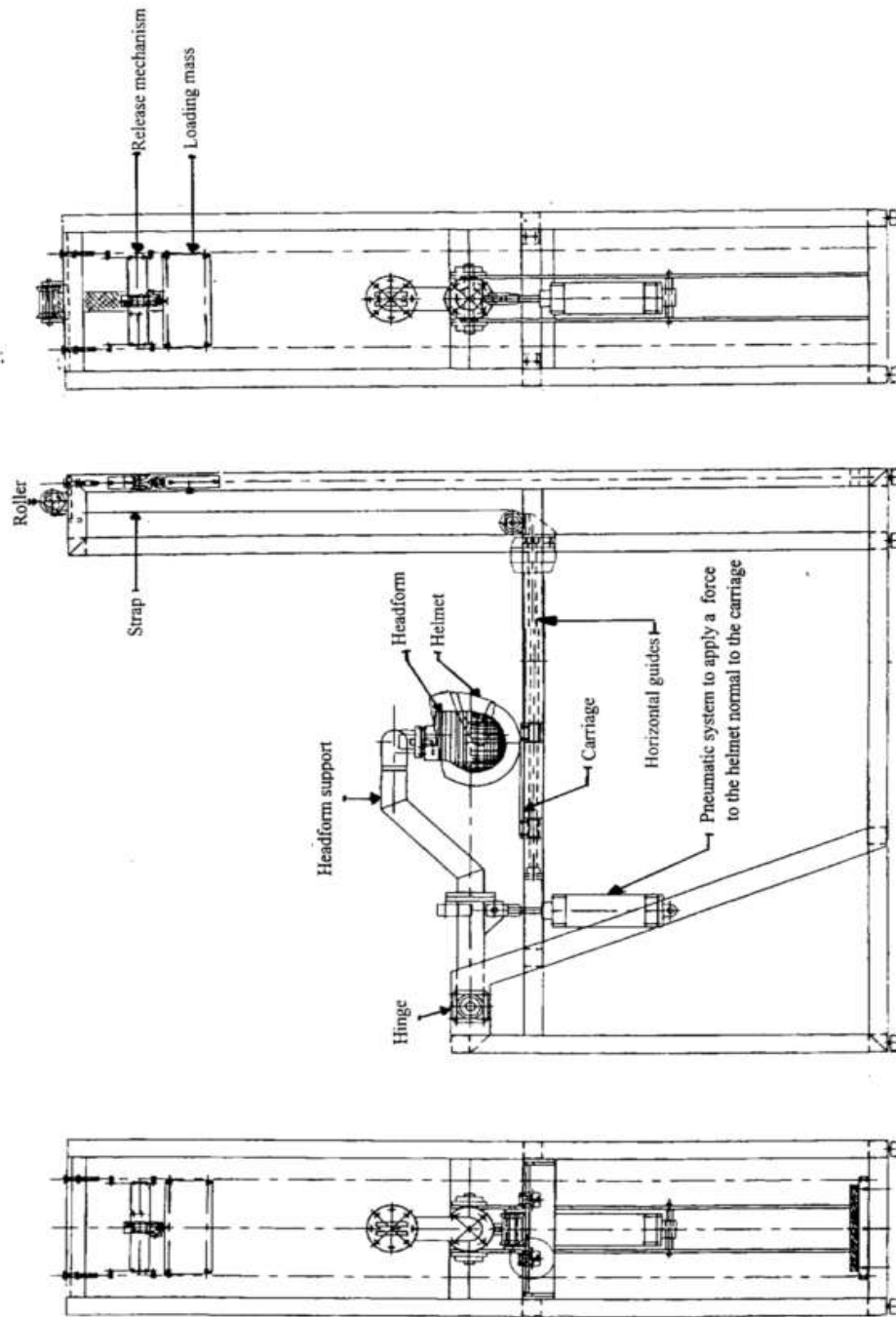

Figure 1c: Example of a suitable test apparatus for projections and surface friction (method B)

Figure 1d: Example of a suitable test apparatus for Rotational
acceleration test

DYNAMIC TEST OF RETENTION SYSTEM

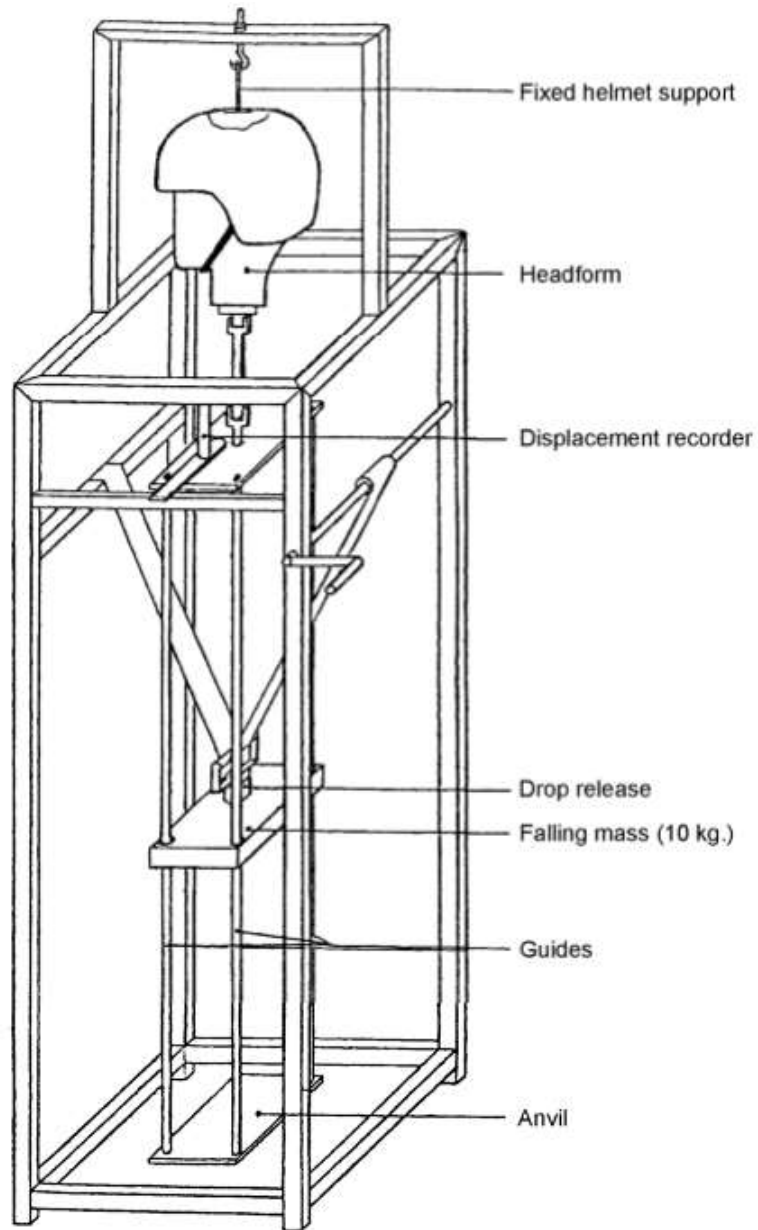

Figure 2

RETENTION (DETACHING) TEST APPARATUS

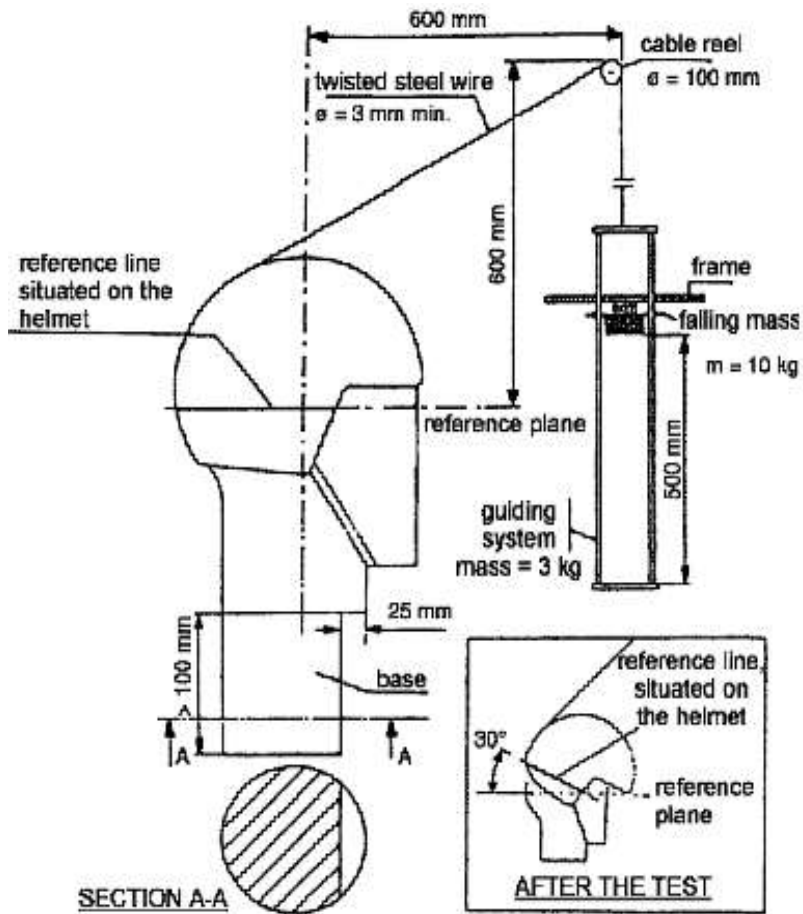

Figure 3

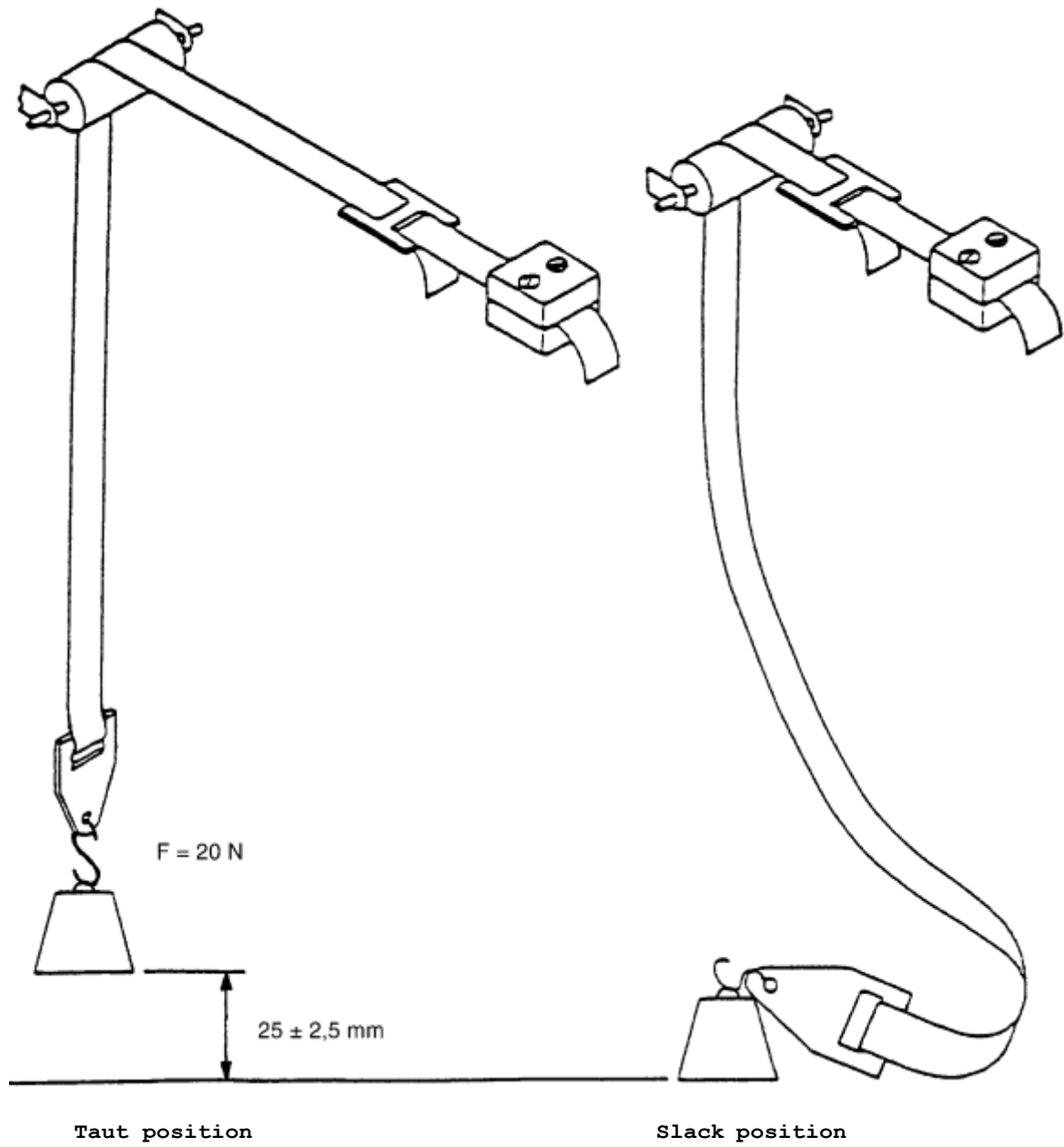

Figure 4: Apparatus for testing slippage of the chin strap

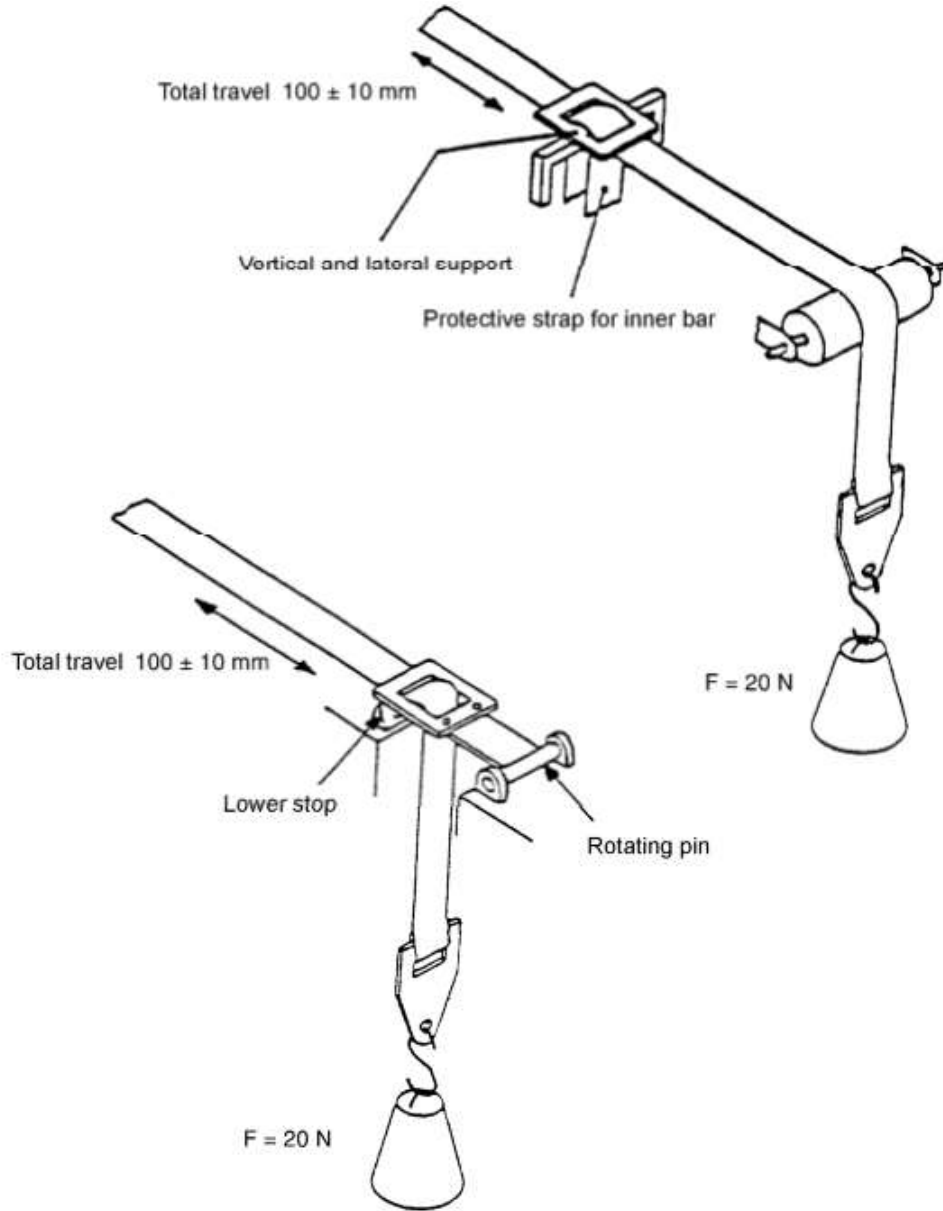
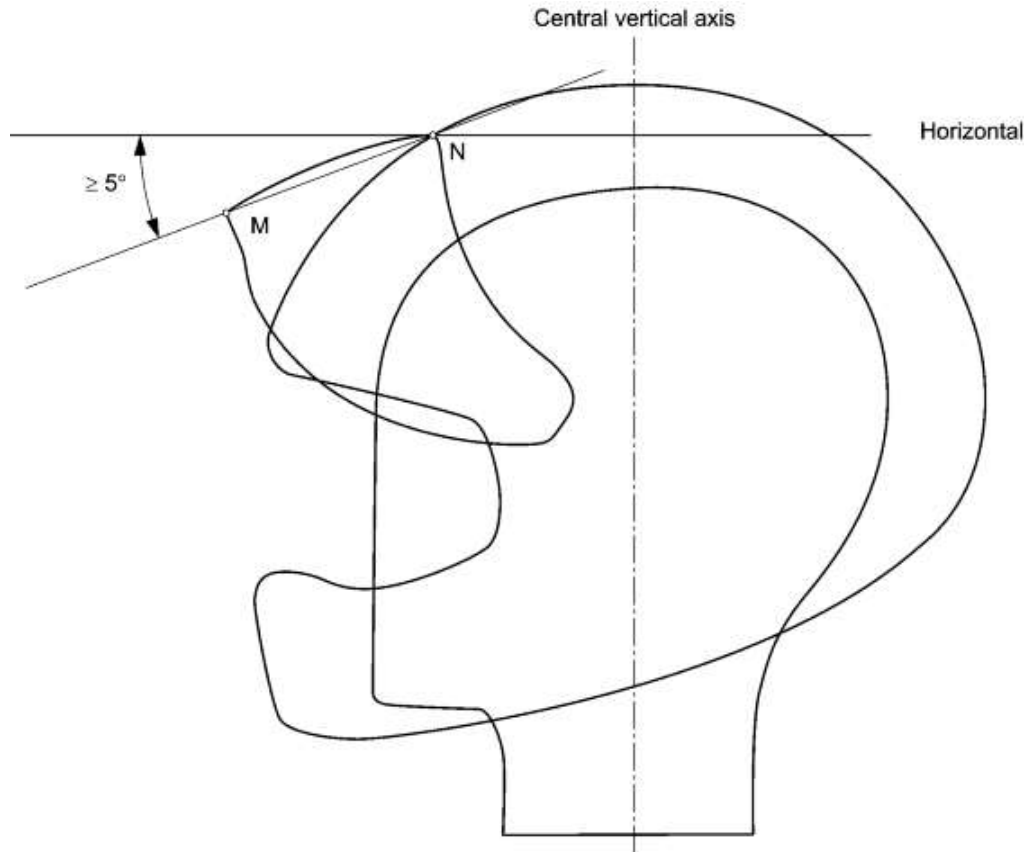

Figure 5: Apparatus for testing abrasion of the chin strap

Annex 9

TESTING OF THE ANGLE OF OPENING OF THE VISOR



The secant line MN is the straight line joining the points of the upper and lower edges of the visor contained in the median vertical plane of the helmet.

Annex 10

ABRASION TEST PROCEDURE

1. DESCRIPTION OF THE TEST EQUIPMENT

The sand spray test equipment consists essentially of that illustrated in Figure 1. The gravity tube consists of three separate rigid polyvinylchloride tubes (PVC hard) of the same diameter, with two polyamide sieves mounted in between. The sieves should have a mesh size of 1.6 mm \pm 0.1 mm. The speed of the turntable shall be 250 \pm 10 rpm.

2. ABRASIVE MATERIAL

Natural quartz sand of a grain size of 0.50/0.7 mm, with no oversize, obtained by sieving on wire sieves complying with ISO 565 with a mesh size of 0.50 mm and 0.7 mm. The sand may be used up to 10 times.

3. TEST PROCEDURE

Three kilograms of 0.50/0.7 mm grain size quartz sand is allowed to drop through a gravity tube from a height of 1,650 mm \pm 15mm onto the sample to be tested. The test piece and, if necessary, a control-piece are mounted on a turntable, the axis of which is at a 45° \pm 3° angle to the direction of the sand.

The test pieces are mounted on the turntable in such a way that the area to be measured does not extend beyond the turntable. Whilst the turntable is rotating, 3 kg of sand are allowed to spray over the test pieces.

Figure 1: Sand spray equipment

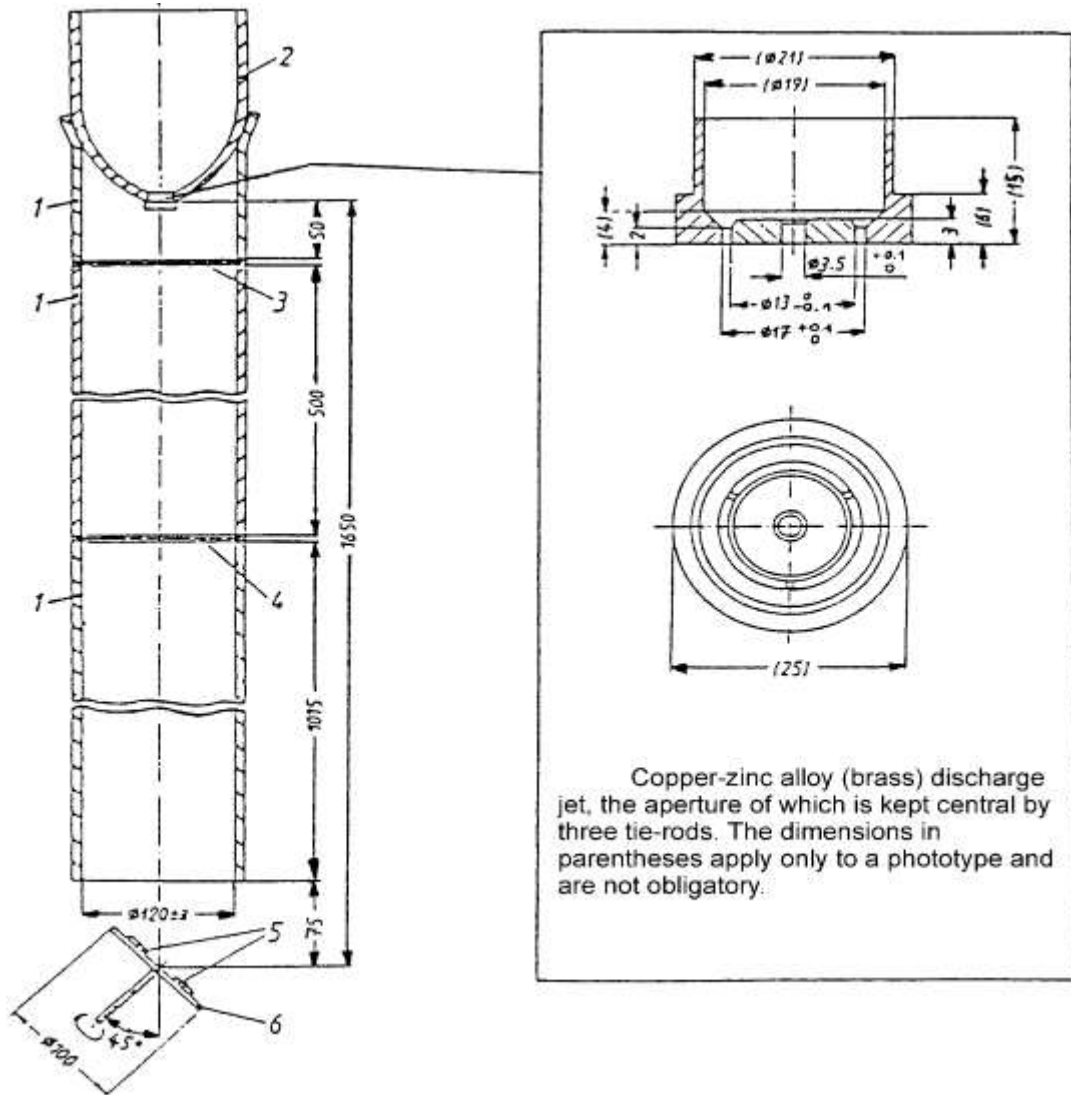

1. Parts of gravity tube
2. Container with discharge jet as figure 2, containing at least 3 kg sand
3. Upper sieve
4. Lower sieve
5. Test piece
6. Test piece holder (turnable)

Annex 11

METHODS OF MEASURING LIGHT DIFFUSION
 AND LIGHT TRANSMISSION COEFFICIENT

1. METHOD (a)

1.1 Equipment

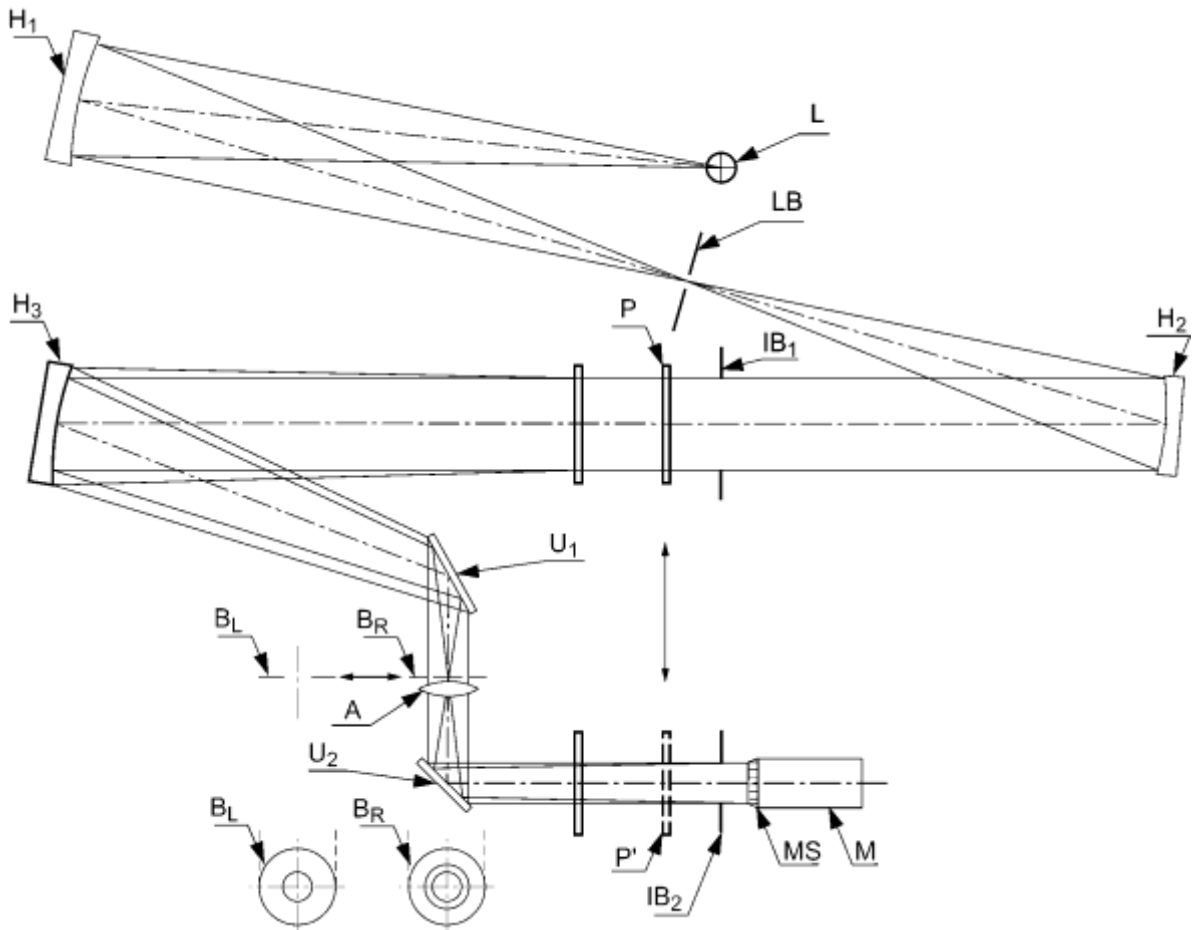

This assembly collects all the unscattered light originating from the visor up to an angle of 0.72 degree (using diaphragm B_L) and all scattered light between the angles 1.5 degrees and 2 degrees in relation to the optical axis using diaphragm B_R . The angular area is important in the case of night riding, where a range in the immediate proximity of headlights has to be observed. The following dimensions are an information for the possible realization:

L	High-pressure xenon lamp (for example XBO 75 W)
H ₁	Spherical concave mirror: focal length 150 mm; diameter 40 mm
H ₂	Spherical concave mirror: focal length 300 mm; diameter 40 mm
H ₃	Spherical concave mirror: focal length 300 mm; diameter 70 mm
A	Achromatic lens: focal length 200 mm; diameter 30 mm
U ₁ , U ₂	Flat mirrors
B _R	Annular diaphragm: diameter of outer circle 21.00 mm; diameter of inner circle 15.75 mm
B _L	Circular diaphragm: diameter of aperture 7.5 mm
M	Silicon detector corrected according to curve V (λ) with diffusing screen MS
IB ₁	Iris-diaphragm to adjust diameter of field of observation, diameter 40 mm
IB ₂	Iris-diaphragm to eliminate edge effects from IB ₁
LB	Circular diaphragm, diameter of aperture 1 mm
P, P'	Positions of visor.

Spherical mirror H₁ forms an image of light source L at diaphragm LB which is in the focal plane of H₂. The concave mirror H₃ forms an image of diaphragm LB in the plane of diaphragms B_L and B_R. The achromatic lens A is positioned immediately behind the diaphragm so that a reduced image of the test sample in position P appears on diffusing screen MS. The image of iris-diaphragm IB₁ is simultaneously formed on IB₂.

1.2. Measurement

The visor is positioned in the parallel beam to position P, then diaphragm B_L is set in place. The flux T_{1L} falling onto the detector corresponds to the undiffused light transmitted by the sample. Diaphragm B_L is then replaced by annular diaphragm B_R; flux T_{1R} falling onto the detector corresponds to the total diffused light originating from the visor and from the apparatus. The visor is then placed at position P'. Flux T_{2R} falling onto the detector corresponds to the diffused light coming from the apparatus only. The visor is then brought out of the light beam (e.g. between P

and P'). The flux T_{OL} falling on the detector with the diaphragm BL in place corresponds to the total light.

1.3. Optical qualities; definitions

1.3.1. Luminous transmittance:

$$\tau = T_{1L}/T_{OL} \times 100$$

1.3.2. Light diffusion before abrasion DB:

$$DB = 597 \times (T_{1R} - T_{2R})/T_{1L}$$

1.3.3. Light diffusion after abrasion:

$$DA = 597 \times (T_{1R} - T_{2R})/T_{1L}$$

2. METHOD (b)

2.1. Equipment (See figure 1)

The beam of a collimator K of semi-divergence $\gamma/2 = 17.4 \times 10^{-4}$ rd is limited by a diaphragm D_1 with an opening of 12 mm against which the sample holder is placed.

An achromatic convergent lens L_2 corrected for spherical irregularities links the diaphragm D_1 with the receiver R, the diameter of the lens L_2 being such that it does not restrict the light diffused by the sample in a cone with a top half angle of $\beta/2 = 14^\circ$.

An annular diaphragm D_2 with extended angles $\alpha_o/2 = 1^\circ$ and $\alpha_{max}/2 = 12^\circ$ is placed in a focal image plane of the lens L_2 (see figure 2).

The non-transparent central part of the diaphragm is necessary to eliminate the light arriving directly from the light source. It must be possible to move the central part of the diaphragm away from the light beam in such a manner that it returns exactly to its original position.

The distance between the lens L_2 and the diaphragm D_1 , and the focal length F_2 1/ of the lens L_2 are to be chosen so that the image of D_1 completely covers the receiver R.

For an initial incident flux of 1,000 units, the absolute precision of each reading shall be better than 1 unit.

1/ For L_2 a focal diameter of about 80 mm is recommended.

2.2. Measurements

The following reading shall be taken:

Reading (T)	With sample	With central part of D ₂	Quantity represented
T ₁	no	no	Incident flux in initial reading
T ₂	yes (before abrasion)	no	Flux transmitted by the new material
T ₃₀	no	yes	Incident light flux with central part of D ₂
T ₃₁	yes (before abrasion)	yes	Flux diffused by the new material
T ₄	yes (after abrasion)	yes	Flux diffused by the abraded material

2.3. Optical quantities definitions

2.3.1. The luminous transmittance is given by:

$$(T_2/T_1) \times 100$$

2.3.2. The light diffusion before abrasion is given by:

$$DB = (T_{31} - T_{30}^*) \times 100/T_2 ; T_{30}^* = T_{30} \times (T_2/T_1)$$

2.3.3. The light diffusion after abrasion is given by:

$$DA = (T_4 - T_{30}^*) \times 100/T_2$$

Note: Markings DA and DB correspond to paragraph 1.3. of this annex.

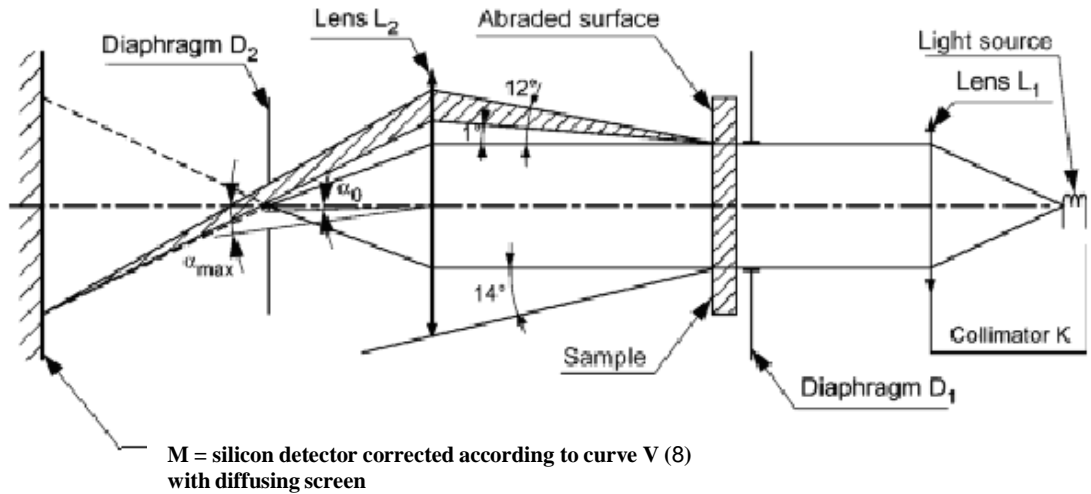

Figure 1: Test equipment

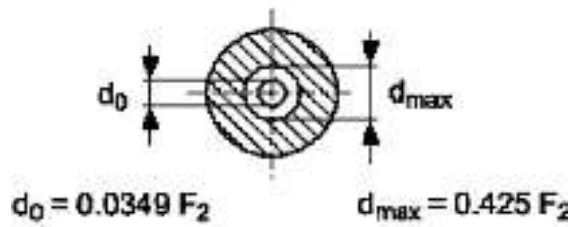

Figure 2: Annular diaphragm D_2

3. METHOD (c)

3.1. Equipment

The test arrangement is shown in figure 3.

Note 1: The measurement principle is identical to the method (a), but the diameter of the measuring is smaller (approximately 2.5 mm) and the test arrangement is simplified.

The beam of the laser (L) is expanded using the two lenses L_1 and L_2 and is directed towards the measuring point of the ocular (P). Ocular (P) is positioned in such a way what it can rotate around the axis of the beam.

The deviation of the beam is a function of the prismatic refractive power at the measuring point.

The annular or circular diaphragm, whichever is chosen, is at a distance of (400 " 2) mm from the centre of the ocular. The lens A then produces the image of the centre of the ocular on the photoreceptor S.

The part of the test arrangement, comprising the diaphragms, the lens and the receptor is designed to rotate about the vertical axis through the centre of the ocular.

The ocular and the detector part of the apparatus has to pivot in order to compensate for any prismatic refractive power of the ocular.

Note 2: For oculars without corrective effect, it is not necessary, in most cases, for the ocular and the detector part to pivot.

3.2. Procedure

3.2.1. Calibration of the apparatus

Set up the apparatus, the essential features of which are shown in figure 3, without the ocular in place. Put the annular diaphragm B_R in place. Rotate the detector part of the apparatus (consisting of a photoreceptor S, a lens A and the annular diaphragm B_R) horizontally about P so as to align the light beam from the beam expander (consisting of a lens L_1 , with a typical focal length of 10 mm, a lens L_2 with a typical focal length of 30 mm and a circular diaphragm B with a pinhole of sufficient size so as to provide a uniform beam) with the centre of the annular diaphragm B_R . Measure the flux Φ_{1R} falling onto the photoreceptor S, corresponding to the total non-diffused light. Replace the annular diaphragm B_R by the circular diaphragm B_L .

Measure the flux Φ_{1L} falling onto the photoreceptor, corresponding to the total non-diffused light.

Obtain the reduced luminance factor for the apparatus, I_a^* , for the solid angle ω using the following equation:

$$I_a^* = \frac{1}{\omega} \cdot \frac{\Phi_{1R}}{\Phi_{1L}}$$

where Φ_{1R} is the luminous flux without the visor in the parallel beam and with the annular diaphragm B_R in place

Φ_{1L} is the luminous flux without the visor in the parallel beam and with circular diaphragm B_L in place

ω is the solid angle defined by the annular diaphragm B_R

3.2.2. Testing of the visor

Place the visor in the parallel beam at position P as shown in figure 3. Repeat paragraph 3.2.1. with the visor in place, and with the visor rotated about the axis of the beam to a position such that the prismatic deviation by the visor is horizontal. Rotate the detector part of the apparatus so that the light beam falls on the centre of B_R . Obtain the reduced luminance factor for the apparatus including the visor, I_g^* , for the solid angle ω using the following equation:

$$I_g^* = \frac{1}{\omega} \cdot \frac{\Phi_{2R}}{\Phi_{2L}}$$

where Φ_{2R} is the luminous flux with the visor in the parallel beam and with the annular diaphragm B_R in place

Φ_{2L} is the luminous flux without the visor in the parallel beam and with circular diaphragm B_L in place

ω is the solid angle defined by the annular diaphragm B_R

Then calculate the reduced luminance factor I^* of the ocular using the following equation:

$$I^* = I_g^* - I_a^*$$

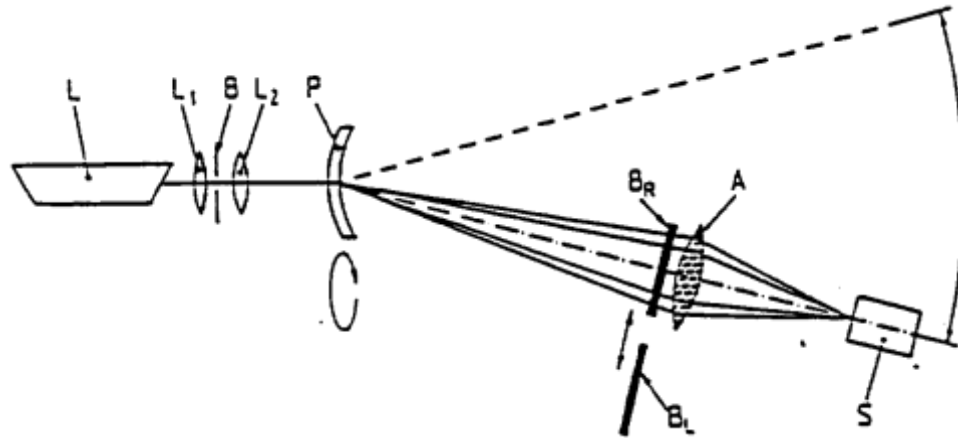

Figure 3: Arrangement of apparatus for measurement of light diffusion - Method (c)

- L = Laser with wavelength of (600 " 70) nm.
Note: Class 2 laser recommended.
 < 1mW. Diameter of beam between 0.6 and 1 mm
- L₁ = 10 mm nominal focal length lens
 L₂ = 30 mm nominal focal length lens
 B = Circular diaphragm - (a hole of 0.1 mm approx produces a uniform light beam)
 P = Visor sample
 B_R = Annular diaphragm, the diameter of the external circle being (28.0 " 0.1) mm and the inner circle (21.0 " 0.1) mm. See Note 2 below.
 B_L = Circular diaphragm of 10 mm nominal diameter
 A = Lens, 200 mm nominal focal length and 30 mm nominal diameter
 S = Photoreceptor

The distance between the annular/circular diaphragm and the centre of the ocular shall be (400 " 2) mm.

Note 1: The focal lengths of the lenses are only given as a guide. Other focal lengths may be used, for example, if a wider beam is desired or a smaller image of the sample is to be formed on the receptor.

Note 2: The diameters of the annular diaphragm circles shall be measured to an uncertainty not exceeding 0.01 mm in order that the solid angle ω may be determined accurately; any deviation from the nominal diameters shall be taken into account by calculation.

Annex 12

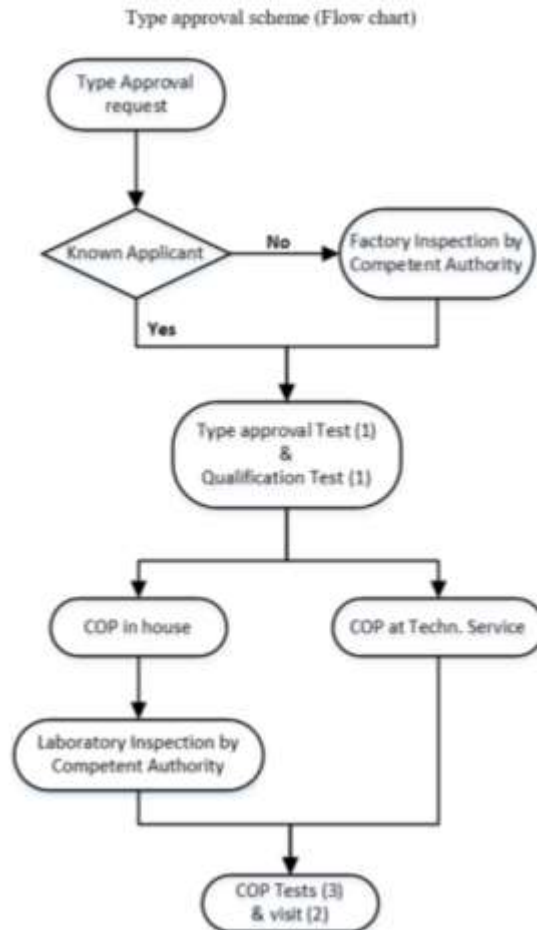

- (1) To be carried out at the same technical service or the same accredited independent laboratory.
- (2) Visit of the manufacturer for inspection and random sampling by the authority or technical service:
 - (a) If there is no ISO 9002* or an equivalent standard: 1 times a year
 - (b) If there is an ISO 9002* or an equivalent standard: 1 time every 1 to 2 years, depending on the results of the inspection.
- (3) Tests in accordance to paragraph 10.5 and/or 10.6 on samples taken out of the production:
 - (a) If there is no ISO 9002*: of the authority or technical service during the visit of footnote 2 a) of the manufacturer between the visits of footnote 2 a)
 - (b) If there is an ISO 9002*: taken by the manufacturer, procedure checked during visit of footnote 2 b)"

* Or an equivalent standard, i.e. one that delivers the same or better levels of quality

Annex 13

DEFINITIONS

The luminous transmittance T_v is defined as:

$$T_v = \frac{\int_{380\text{nm}}^{780\text{nm}} S_{D65\lambda}(\lambda) \cdot V(\lambda) \cdot T_F(\lambda) \cdot d\lambda}{\int_{380\text{nm}}^{780\text{nm}} S_{D65\lambda}(\lambda) \cdot V(\lambda) \cdot d\lambda}$$

The relative visual attenuation quotient Q is defined as:

$$Q = \frac{T_{\text{sign}}}{T_v}$$

where:

T_v is the luminous transmittance of the visor relative to the standard illuminant D65

T_{sign} is the luminous transmittance of the visor relative to the spectral power distribution of the traffic signal light and it is given by the following equation:

$$T_{\text{sign}} = \frac{\int_{380\text{nm}}^{780\text{nm}} S_{A\lambda}(\lambda) \cdot V(\lambda) \cdot T_F(\lambda) \cdot T_S(\lambda) \cdot d\lambda}{\int_{380\text{nm}}^{780\text{nm}} S_{A\lambda}(\lambda) \cdot V(\lambda) \cdot T_S(\lambda) \cdot d\lambda}$$

where:

$S_{A\lambda}(\lambda)$ is the spectral distribution of radiation of CIE standard illuminant A (or 3200 K light source for blue signal light). See: ISO/CIE 10526, "CIE standard colorimetric illuminants";

$S_{D65\lambda}(\lambda)$ is the spectral distribution of radiation of CIE standard illuminant D65. See: ISO/CIE 10526, "CIE standard colorimetric illuminants";

$V(\lambda)$ is the spectral visibility function for daylight vision. See: ISO/CIE 10527, "CIE standard colorimetric observers";

$T_S(\lambda)$ is the spectral transmittance of the traffic signal lens;

$T_v(\lambda)$ is the spectral transmittance of the visor.

The spectral value of the product of the spectral distributions $(S_{\lambda\lambda}(\lambda) \cdot S_{D65\lambda}(\lambda))$ of the illuminant, the spectral visibility function $v(\lambda)$ of the eye and the spectral transmittance $T_s(\lambda)$ of the traffic signal lenses are given in annex B.

Annex 14

Product of the energy distribution of Standard Illuminant D65 as specified in ISO 11664-2 and the spectral visibility function of the average human eye for daylight vision as specified in ISO 11664-1

Table D.1 — Product of the energy distribution of Standard Illuminant D65 and the spectral visibility function of the average human eye for daylight vision

Wavelength λ nm	$S_{D65}(\lambda) \cdot V(\lambda)$	Wavelength λ nm	$S_{D65}(\lambda) \cdot V(\lambda)$	Wavelength λ nm	$S_{D65}(\lambda) \cdot V(\lambda)$
380	0,0001	515	3,0589	650	0,4052
385	0,0002	520	3,5203	655	0,3093
390	0,0003	525	3,9873	660	0,2315
395	0,0007	530	4,3922	665	0,1714
400	0,0016	535	4,5905	670	0,1246
405	0,0026	540	4,7128	675	0,0881
410	0,0052	545	4,8343	680	0,0630
415	0,0095	550	4,8981	685	0,0417
420	0,0177	555	4,8272	690	0,0271
425	0,0311	560	4,7078	695	0,0191
430	0,0476	565	4,5455	700	0,0139
435	0,0763	570	4,3393	705	0,0101
440	0,1141	575	4,1607	710	0,0074
445	0,1564	580	3,9431	715	0,0048
450	0,2104	585	3,5626	720	0,0031
455	0,2667	590	3,1766	725	0,0023
460	0,3345	595	2,9377	730	0,0017
465	0,4068	600	2,6873	735	0,0012
470	0,4945	605	2,4084	740	0,0009
475	0,6148	610	2,1324	745	0,0006
480	0,7625	615	1,8506	750	0,0004
485	0,9001	620	1,5810	755	0,0002
490	1,0710	625	1,2985	760	0,0001
495	1,3347	630	1,0443	765	0,0001
500	1,6713	635	0,8573	770	0,0001
505	2,0925	640	0,6931	775	0,0001
510	2,5657	645	0,5353	780	0,0000
				Sum	100,0000

Spectral distribution of radiation in incandescent signal lights weighted by the sensitivity of the human eye $V(\lambda)$

Table H.1 — Spectral distribution of radiation in signal lights weighted by the sensitivity of the human eye $V(\lambda)$

Wavelength	Red	Yellow	Green	Blue
λ (nm)	$E_{Red}(\lambda)$ $\cdot V(\lambda)$	$E_{Yellow}(\lambda)$ $\cdot V(\lambda)$	$E_{Green}(\lambda)$ $\cdot V(\lambda)$	$E_{Blue}(\lambda)$ $\cdot V(\lambda)$
380	0,000	0,000	0,000	0,000
385	0,000	0,000	0,000	0,000
390	0,000	0,000	0,000	0,000
395	0,000	0,000	0,000	0,000
400	0,000	0,000	0,000	0,010
405	0,000	0,000	0,000	0,010
410	0,000	0,000	0,000	0,030
415	0,000	0,000	0,000	0,060
420	0,000	0,000	0,000	0,120
425	0,000	0,000	0,000	0,250
430	0,000	0,000	0,000	0,440
435	0,000	0,000	0,010	0,680
440	0,000	0,000	0,020	0,970
445	0,000	0,000	0,030	1,260
450	0,000	0,000	0,050	1,600
455	0,000	0,000	0,080	1,950
460	0,000	0,000	0,120	2,350
465	0,000	0,000	0,180	2,760
470	0,000	0,000	0,270	3,230
475	0,000	0,010	0,380	3,720
480	0,000	0,010	0,540	4,240
485	0,000	0,020	0,740	4,650
490	0,000	0,040	1,020	5,080
495	0,000	0,070	1,410	5,510
500	0,010	0,120	1,910	5,870
505	0,010	0,200	2,610	6,450
510	0,010	0,320	3,430	6,800
515	0,010	0,490	4,370	6,660
520	0,010	0,760	5,320	5,950
525	0,020	1,160	6,130	5,150

Wavelength	Red	Yellow	Green	Blue
λ (nm)	$E_{Red}(\lambda)$ $\cdot V(\lambda)$	$E_{Yellow}(\lambda)$ $\cdot V(\lambda)$	$E_{Green}(\lambda)$ $\cdot V(\lambda)$	$E_{Blue}(\lambda)$ $\cdot V(\lambda)$
530	0,020	1,700	6,860	3,960
535	0,020	2,350	7,370	3,370
540	0,020	3,060	7,700	2,650
545	0,020	3,710	7,750	2,320
550	0,020	4,260	7,340	1,940
555	0,020	4,730	6,460	1,460
560	0,030	5,050	5,480	0,970
565	0,040	5,270	4,790	0,660
570	0,080	5,440	4,340	0,360
575	0,230	5,470	3,770	0,280
580	0,670	5,430	3,040	0,200
585	1,640	5,320	2,400	0,220
590	3,320	5,160	1,790	0,240
595	5,400	4,940	1,050	0,230
600	7,320	4,670	0,400	0,230
605	8,750	4,380	0,120	0,180
610	9,350	4,040	0,050	0,130
615	9,320	3,640	0,060	0,100
620	8,950	3,270	0,090	0,060
625	8,080	2,840	0,110	0,070
630	7,070	2,420	0,100	0,070
635	6,100	2,030	0,070	0,160
640	5,150	1,700	0,040	0,210
645	4,230	1,390	0,020	0,430
650	3,410	1,110	0,020	0,540
655	2,690	0,870	0,010	0,420
660	2,090	0,670	0,000	0,320
665	1,570	0,510	0,000	0,210
670	1,150	0,370	0,000	0,140
675	0,850	0,280	0,000	0,260
680	0,640	0,210	0,000	0,300
685	0,470	0,150	0,000	0,320
690	0,330	0,100	0,000	0,300
695	0,240	0,070	0,000	0,230
700	0,180	0,060	0,010	0,180
705	0,130	0,040	0,020	0,130
710	0,090	0,030	0,020	0,100
715	0,070	0,020	0,020	0,070
720	0,050	0,010	0,020	0,050

Wavelength	Red	Yellow	Green	Blue
λ (nm)	$E_{Red}(\lambda)$ $\cdot V(\lambda)$	$E_{Yellow}(\lambda)$ $\cdot V(\lambda)$	$E_{Green}(\lambda)$ $\cdot V(\lambda)$	$E_{Blue}(\lambda)$ $\cdot V(\lambda)$
725	0,030	0,010	0,020	0,030
730	0,020	0,010	0,010	0,030
735	0,020	0,010	0,010	0,020
740	0,010	0,000	0,010	0,010
745	0,010	0,000	0,010	0,010
750	0,010	0,000	0,000	0,010
755	0,010	0,000	0,000	0,010
760	0,010	0,000	0,000	0,010
765	0,000	0,000	0,000	0,000
770	0,000	0,000	0,000	0,000
775	0,000	0,000	0,000	0,000
780	0,000	0,000	0,000	0,000
Sum	100,000	100,000	100,000	100,000

Spectral distribution of radiation in LED signal lights weighted by the sensitivity of the human eye $V(\lambda)$

Table I.1 — Spectral distribution of radiation in LED signal lights weighted by the sensitivity of the human eye $V(\lambda)$

Wavelength	Red LED	Yellow LED	Green LED	Blue LED
λ (nm)	$E'_{\text{Red}}(\lambda)$ $\cdot V(\lambda)$	$E'_{\text{Yellow}}(\lambda)$ $\cdot V(\lambda)$	$E'_{\text{Green}}(\lambda)$ $\cdot V(\lambda)$	$E'_{\text{Blue}}(\lambda)$ $\cdot V(\lambda)$
380	0,000	0,000	0,000	0,000
385	0,000	0,000	0,000	0,000
390	0,000	0,000	0,000	0,000
395	0,000	0,000	0,000	0,000
400	0,000	0,000	0,000	0,000
405	0,000	0,000	0,000	0,000
410	0,000	0,000	0,000	0,000
415	0,000	0,000	0,000	0,000
420	0,000	0,000	0,000	0,000
425	0,000	0,000	0,000	0,010
430	0,000	0,000	0,000	0,050
435	0,000	0,000	0,000	0,170
440	0,000	0,000	0,010	0,550
445	0,000	0,000	0,010	1,650
450	0,000	0,000	0,020	4,470
455	0,000	0,000	0,040	9,600
460	0,000	0,000	0,090	14,170
465	0,000	0,000	0,190	13,990
470	0,000	0,000	0,450	11,180
475	0,000	0,000	1,010	9,070
480	0,000	0,000	2,130	7,370
485	0,000	0,000	4,000	5,470
490	0,000	0,000	6,530	4,210
495	0,000	0,000	9,380	3,380
500	0,000	0,000	11,340	2,690
505	0,000	0,000	11,820	2,160
510	0,000	0,000	11,150	1,760
515	0,000	0,000	9,840	1,410
520	0,000	0,010	8,220	1,140

Wavelength	Red LED	Yellow LED	Green LED	Blue LED
λ (nm)	$E'_{Red}(\lambda)$ $\cdot V(\lambda)$	$E'_{Yellow}(\lambda)$ $\cdot V(\lambda)$	$E'_{Green}(\lambda)$ $\cdot V(\lambda)$	$E'_{Blue}(\lambda)$ $\cdot V(\lambda)$
525	0,000	0,010	6,550	0,900
530	0,000	0,020	4,890	0,690
535	0,000	0,030	3,570	0,570
540	0,000	0,050	2,630	0,480
545	0,000	0,120	1,870	0,410
550	0,000	0,240	1,290	0,330
555	0,010	0,500	0,930	0,270
560	0,020	1,000	0,630	0,220
565	0,040	1,850	0,430	0,220
570	0,070	3,390	0,300	0,200
575	0,110	6,080	0,210	0,170
580	0,210	11,180	0,140	0,140
585	0,400	20,100	0,090	0,110
590	0,690	26,720	0,070	0,140
595	1,110	18,530	0,050	0,120
600	1,710	6,910	0,030	0,090
605	2,520	2,200	0,020	0,070
610	3,640	0,700	0,020	0,090
615	5,350	0,230	0,010	0,050
620	7,990	0,080	0,010	0,040
625	12,220	0,030	0,010	0,030
630	17,410	0,010	0,010	0,040
635	19,030	0,010	0,010	0,040
640	14,200	0,000	0,000	0,020
645	7,800	0,000	0,000	0,020
650	3,380	0,000	0,000	0,010
655	1,320	0,000	0,000	0,010
660	0,490	0,000	0,000	0,010
665	0,180	0,000	0,000	0,010
670	0,060	0,000	0,000	0,000
675	0,030	0,000	0,000	0,000
680	0,010	0,000	0,000	0,000
685	0,000	0,000	0,000	0,000
690	0,000	0,000	0,000	0,000
695	0,000	0,000	0,000	0,000
700	0,000	0,000	0,000	0,000
705	0,000	0,000	0,000	0,000
710	0,000	0,000	0,000	0,000

Wavelength	Red LED	Yellow LED	Green LED	Blue LED
λ (nm)	$E'_{Red}(\lambda)$ $\cdot V(\lambda)$	$E'_{Yellow}(\lambda)$ $\cdot V(\lambda)$	$E'_{Green}(\lambda)$ $\cdot V(\lambda)$	$E'_{Blue}(\lambda)$ $\cdot V(\lambda)$
715	0,000	0,000	0,000	0,000
720	0,000	0,000	0,000	0,000
725	0,000	0,000	0,000	0,000
730	0,000	0,000	0,000	0,000
735	0,000	0,000	0,000	0,000
740	0,000	0,000	0,000	0,000
745	0,000	0,000	0,000	0,000
750	0,000	0,000	0,000	0,000
755	0,000	0,000	0,000	0,000
760	0,000	0,000	0,000	0,000
765	0,000	0,000	0,000	0,000
770	0,000	0,000	0,000	0,000
775	0,000	0,000	0,000	0,000
780	0,000	0,000	0,000	0,000
Sum	100,000	100,000	100,000	100,000

Annex 15

TEST OF REFRACTIVE POWERS

1. Spherical and astigmatic refractive powers

1.1. Apparatus

1.1.1. Telescope

A telescope with an aperture nominally 20 mm and a magnification between 10 and 30, fitted with an adjustable eyepiece incorporating a reticular.

1.1.2. Illuminated target

A target, consisting of a black plate incorporating the cut-out pattern shown in figure 1, behind which is located a light source of adjustable luminance with a condenser, if necessary, to focus the magnified image of the light source on the telescope objective.

The large annulus of the target has an outer diameter of 23 ± 0.1 mm with an annular aperture of 0.6 ± 0.1 mm. The small annulus has an inner diameter of 11.0 ± 0.1 mm with annular aperture of 0.6 ± 0.1 mm. The central aperture has a diameter of 0.6 ± 0.1 mm. The bars are nominally 20 mm long and 2 mm wide with a nominal 2 mm separation.

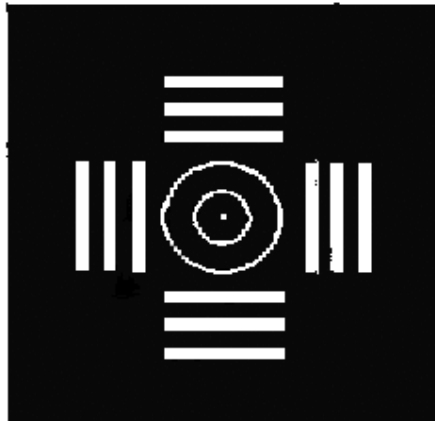

Figure 1: Telescope target

1.1.3. Filter

A filter with its maximum transmittance in the green part of the spectrum may be used to reduce chromatic aberrations.

1.1.4. Calibration lenses

Lenses with positive and negative spherical refractive powers of 0.06 m^{-1} , 0.12 m^{-1} and 0.25 m^{-1} (tolerance $\pm 0.01 \text{ m}^{-1}$).

1.2. Arrangement and calibration of apparatus

The telescope and illuminated target are placed on the same optical axis $4.60 \pm 0.02 \text{ m}$ apart.

The observer focuses the reticule and the target and aligns the telescope to obtain a clear image of the pattern. This setting is regarded as the zero point of the focusing scale of the telescope.

The focusing adjustment of the telescope is calibrated with the calibration lenses (paragraph 1.1.4.) so that a power of 0.01 m^{-1} may be measured. Any other calibration method may be used.

1.3. Procedure

The visor is mounted in front of the telescope as worn and measurements shall be taken at the sign points as specified in paragraph 6.15.3.8.

1.3.1. Spherical and astigmatic refractive powers

1.3.1.1. Visors without astigmatic refractive power

The telescope is adjusted until the image of the target is perfectly resolved.

The spherical power of the visor is then read from the scale of the telescope.

1.3.1.2. Visor with astigmatic refractive power

The target, on the visor, is rotated in order to align the principal meridians of the visor with the bars on the target. The telescope is focused firstly on one set of bars (measurement D_1) and then on the perpendicular bars (measurement D_2). The spherical

power is the mean, $\frac{D_1 + D_2}{2}$, the astigmatic refractive power is the

absolute difference, $| D_1 - D_2 |$, of the two measurements.

2. Determination of the difference in prismatic refractive power

2.1. Apparatus

The arrangement of the reference method is shown in figure 2.

2.2.1. Procedure

The diaphragm LB_1 , illuminated by the light source, is adjusted in such a way that it produces an image on the plane B when the visor (P) is not in position. The visor is placed in front of the lens L_2 so that the axis of the visor is parallel to the optical axis of the test assembly.

Adjustable tilt visors are positioned with their ocular regions normal to the optical axis of the equipment.

Measure the vertical and horizontal distance between the two displaced images arising from the two ocular areas of the visor.

These distance in cm are divided by 2 to give the horizontal and vertical prismatic difference in cm/m.

If the light paths which correspond to the two eye regions cross, the prismatic refractive power is "base in" and if the light paths do not cross, it is "base out".

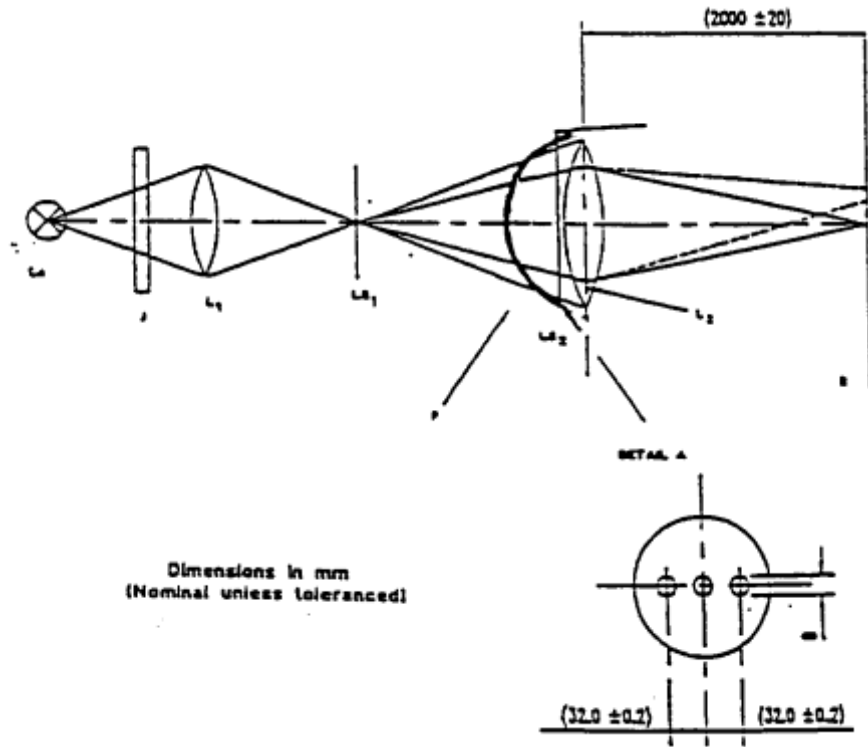

Figure 2: Arrangement apparatus for measurement of prismatic difference

- L_a = light source, for example, small filaments lamp, laser with wavelength of 600 ± 70 nm, etc.
- J = interface filter, with peak transmittance in the green part of the spectrum (required only if a filament lamp is used as the light source).
- L_1 = achromatic lens focal length between 20 and 50 mm.
- LB_1 = diaphragm, diameter of aperture 1 mm nominal
- P = visor
- LB_2 = diaphragm as shown in detail A
- L_2 = achromatic lens, 1,000 mm nominal focal length and 75 mm nominal diameter
- B = image plane

Annex 16

TEST FOR MIST-RETARDANT VISOR

1. Apparatus

Apparatus to determine the change in the non-diffused transmittance value, as shown in figure 1.

The nominal diameter of the parallel beam is 10 mm. The size of the beam divider, reflector R and lens L_3 shall be selected in such a way that diffused light is captured up to an angle of 0.75° . If a lens L_3 with a nominal focal length $f_3 = 400$ mm is used, the nominal diameter of a diaphragm is 10 mm. The plane of the diaphragm must lie within the focal plane of the lens L_3 .

The following focal lengths f_i of the lens L_i are nominal examples and will not affect the test results:

$$f_1 = 10 \text{ mm and } f_2 = 100 \text{ mm}$$

The light source shall be a laser with a wavelength of 600 ± 70

nm. The volume of air above the water bath is at least 4 litres. The seating ring has a nominal diameter of 35 mm and a nominal height of 24 mm is then measured to the highest point of the seating ring. A soft rubber ring, 3 mm thick and 3 mm wide (nominal dimensions), is inserted between the sample and the seating ring.

The water bath container also contains a ventilator to circulate the air. In addition, there must also be a device to stabilize the temperature on the water bath.

2. Samples

At least 3 samples of the same type are to be tested. Before the test, the samples are conditioned for one hour in distilled water (at least 5 cm^3 water per cm^2 sample surface area) at $23 \pm 5^\circ \text{C}$, then dabbed dry and then conditioned in air for at least 12 hours at $23 \pm 5^\circ \text{C}$ and 50 per cent nominal relative humidity.

3. Procedure and evaluation

The ambient temperature during the measurement is $23 \pm 5^\circ \text{C}$.

The temperature of the water bath is set at $50 \pm 0.5^\circ \text{C}$. The air above the water bath is circulated using a ventilator, so that it becomes saturated with water vapor. During this time, the measurement opening is to be covered. The ventilator is switched off before the measurement.

To measure the change in the value of the transmittance τ_r the sample is placed on the seating ring and the time determined until the square of τ_r has dropped to less than 80 per cent of the initial value of the sample without fogging (time without fogging).

$$\tau_r^2 = \frac{\Phi_b}{\Phi_u}$$

where:

Φ_b is the luminous flux when there is fogging on the sample

Φ_u is the luminous flux before fogging

Initial fogging of maximum 0.5 s duration shall not be taken into consideration in the evaluation.

Note 1: Since the light beam passes through the samples twice, this measurement defines τ_r^2 .

Note 2: The period until the start of the fogging can usually be determined visually. However, with some types of coating the formulation of the surface water causes diffusion to increase more slowly so that visual evaluation is difficult. The detection apparatus described in paragraph 1.1. should then be used.

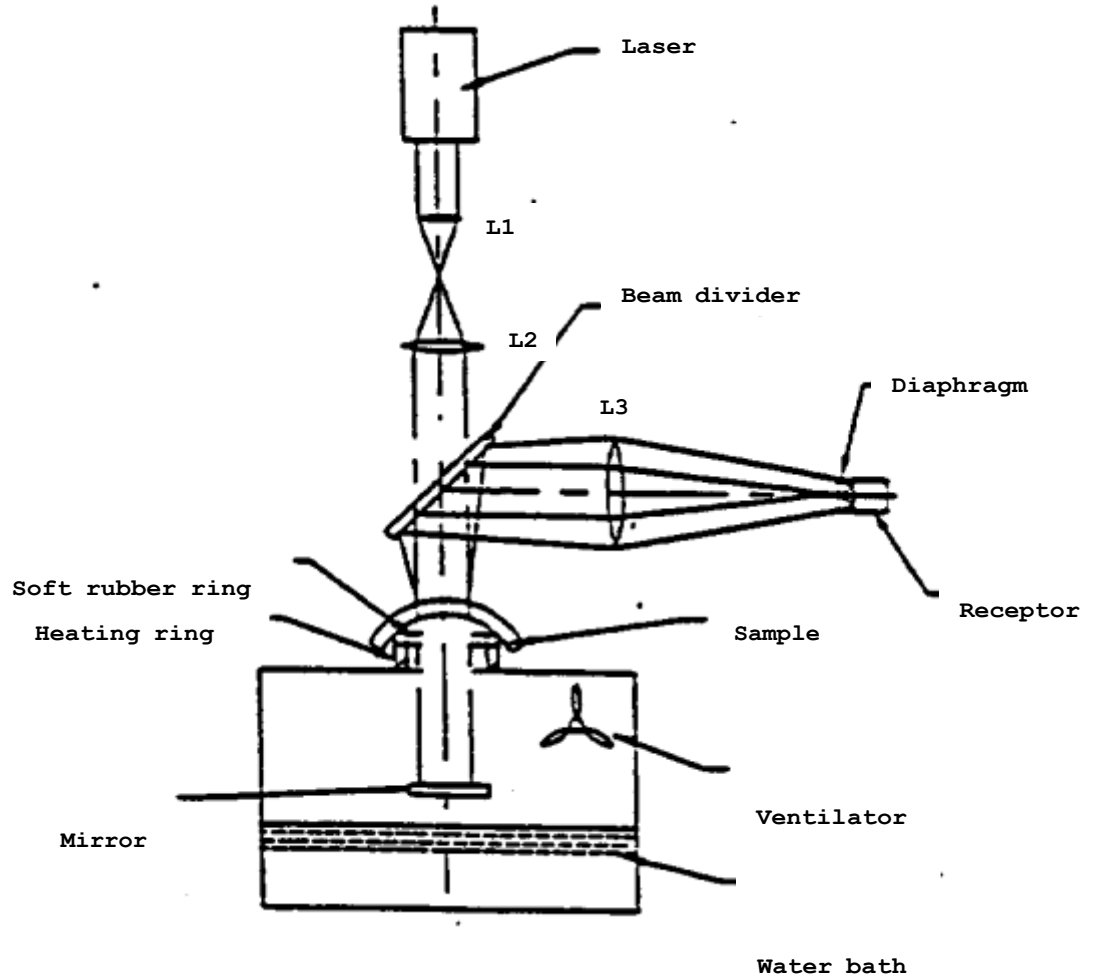

Figure 1: Test apparatus for mist-retardant visor