

# **Proposal for a new UN Regulation on uniform provisions concerning the approval of devices for reversing motion and motor vehicles with regard to the driver's awareness of vulnerable road users behind vehicles**

Red: Update from previous document

Green: [OICA comments or proposals] Review in progress in OICA.

## **I. Proposal**

### **UN Regulation No. XXX**

#### **Proposal for a new UN Regulation on uniform provisions concerning the approval of devices for reversing motion and motor vehicles with regard to the driver's awareness of vulnerable road users behind vehicles**

#### **0. Introduction (for information)**

- 0.1. The purpose of this regulation is to provide the provisions of reversing safety concerning on awareness of vulnerable road users proximity. UN regulation No.46. provides the provisions of indirect vision of motor vehicles. This regulation is to expand driver's vision or awareness for vehicle rear side direction when vehicles in reversing motion. Therefore some requirements of this regulation can be satisfied with the devices for UN regulation No.46.

#### **1. Scope**

This Regulation applies to:

- 1.1. Approval of devices for reversing safety defined in part I intended to be fitted to vehicles of category [M and N].
- 1.2. Approval of vehicle installation of devices for reversing safety defined in part II if fitted to vehicles of category [M and N].
- 1.3. At the request of the manufacturer, Contracting Parties may grant approvals under Parts I and II to vehicles of other categories and devices for fitment to such vehicles.
- 1.4 **Exemption to be proposed by OICA.**

[OICA PROPOSAL]

- 1.4        **The following vehicles of category M and N do not need to comply this regulation,**
- **Vehicles that can not be reached reversing motion requirements because it is not compatible with its use (with the agreement of the technical service)**
  - **The Vehicles fitted with an active system (for instance reversing AEB)**
- 1.5        **If a vehicle has multiple devices, only devices declared by the manufacturer have to meet the provisions of the regulation**

**I.        Devices for Reversing Motion**

**2.        Definitions**

For the purposes of this Regulation:

- 2.1.        "*Devices for indirect vision*" means devices intended to give a clear view of the rear, side or front of the vehicle within the fields of vision defined in paragraph 15.2.3. These can be conventional mirrors, camera-monitors or other devices able to present information about the indirect field of vision to the driver.
- 2.1.1.      "*Mirror*" means any device, excluding devices such as periscopes, intended to give a clear view to the rear, side or front of the vehicle within the fields of vision defined in paragraph 15.2.3. by means of a reflective surface.

[OICA COMMENT]

UN Regulation No.107 allows for periscope for upper decks, which is a mirror to mirror technique:  
Why it is not allowed in this regulation as we are covering very slow manoeuvres?

*Annex 2 :*

*7.18. Vision and communication aid*

*In the case of a vehicle without a roof, the driver shall be provided with a visual means, such as a mirror, **periscope** or video camera/monitor, to enable the behaviour of passengers in the area without a roof to be observed. In addition, an intercommunication system shall be provided to enable the driver to communicate with these passengers.*

- 2.1.1.1.    "*Interior mirror*" means a device as defined in paragraph 2.1.1. above, which can be fitted in the passenger compartment of a vehicle.
- 2.1.1.2.    "*Exterior mirror*" means a device as defined in paragraph 2.1.1. above, which can be mounted on the external surface of a vehicle.
- 2.1.1.3.    "*Surveillance mirror*" means a mirror other than the ones defined in paragraph 2.1.1. above which can be fitted to the inside or outside of the vehicle in order to provide fields of vision other than those specified in paragraph 15.2.3. of this Regulation.
- 2.1.1.4.    "*r*" means the average of the radii of curvature measured over the reflecting surface, in accordance with the method described in Annex 7.

- 2.1.1.5. "*The radius of curvature at one point on the reflecting surface ( $r_p$ )*" means the arithmetical average of the principal radii of curvature  $r_i$  and  $r_i'$ , i.e.:

$$r_p = \frac{r_i + r_i'}{2}$$

- 2.1.1.6. "*Spherical surface*" means a surface, which has a constant and equal radius in all directions.
- 2.1.1.7. "*Aspherical surface*" means a surface, which has only in one plane a constant radius.
- 2.1.1.8. "*Aspherical mirror*" means a mirror composed of a spherical and an aspherical part, in which the transition of the reflecting surface from the spherical to the aspherical part has to be marked. The curvature of the main axis of the mirror is defined in the x/y coordinate system defined by the radius of the spherical primary calotte with:

$$y = R - \sqrt{(R^2 - x^2)} + k(x - a)^3$$

Where:

R: nominal radius in the spherical part

k: constant for the change of curvature

a: constant for the spherical size of the spherical primary calotte

- 2.1.1.9. "*Centre of the reflecting surface*" means the centre of the visible area of the reflecting surface.
- 2.1.1.10. "*The radius of curvature of the constituent parts of the mirror*" means the radius "c" of the arc of the circle which most closely approximates to the curved form of the part in question.
- 2.1.2. "*Camera-monitor system (CMS)*" means a device for indirect vision as defined in paragraph 2.1., where the field of vision is obtained by means of a camera-monitor combination as defined in paragraphs 2.1.2.1. and 2.1.2.2. below.
- 2.1.2.1. "*Camera*" means a device that renders an image of the outside world and then converts this image into a signal (e.g. video signal).
- 2.1.2.2. "*Monitor*" means a device that converts a signal into images that are rendered into the visual spectrum.
- 2.1.3. "*Other devices for indirect vision*" means devices as defined in paragraph 2.1. above, where the field of vision is not obtained by means of a mirror or a camera-monitor device.
- 2.1.4. "*Luminance contrast*" means the brightness ratio between an object and its immediate background/surrounding that allows the object to be distinguished from its background/surroundings. The definition is in accordance with the definition given in ISO 9241-302:2008.
- 2.1.5. "*Resolution*" means the smallest detail that can be discerned with a perceptual system, i.e. perceived as separate from the larger whole. The resolution of the human eye is indicated as "visual acuity".

- 
- 2.1.6. "*Critical object*" means a cylindrical object with a height of 1.0 m and a diameter of 0.30 m.
- 2.1.7. "*Critical perception*" means the level of perception that can just be obtained under critical conditions via the viewing system used. This corresponds to the situation in which the representative scale of the critical object is multiple times larger than the smallest detail that can be perceived via the viewing system.
- 2.1.8. "*Field of vision*" means the section of the tri-dimensional space which is monitored with the help of a device for indirect vision. Unless otherwise stated, this is based on the view on **ground level** offered by a device and/or devices other than mirrors. This may be limited by the relevant detection distance corresponding to the critical object.

[OICA COMMENT]

The required field of vision is a volume and not the surface?

- 2.1.9. "*Detection distance*" means the distance measured from the centre of the lens of the camera to the point at which a critical object can just be perceived (as defined by the critical perception).
- 2.1.10. "*Visual spectrum*" means light with a wavelength within the range of the perceptual limits of the human eyes: 380-780 nm.
- 2.1.11. "*Smear*" is a bright line displayed on the monitor while sun light or light from other bright light sources is directly hitting into the lens of the camera.
- 2.1.12. "*Detection System*" means a system which uses both audible and optical signals, to enable the driver to detect objects in the area adjacent to the vehicle. This system shall fulfil the provisions of **17. and Annex 13.**

[OICA PROPOSAL]

Procedures and requirements regarding signals must be updated too.

- 2.1.12. "*Detection System*" means a system which uses ~~both audible and optical~~ signals, to enable the driver to detect objects in the area adjacent to the vehicle. This system shall fulfil the provisions of **17. and Annex 13.**
- 2.1.13. "*Audible information*" means information using auditory signals provided by detection system as defined in paragraph 2.1.12. above to enable the driver to detect objects in the area adjacent to the vehicle. This system shall fulfil the provisions of **Annex 13.**
- 2.1.14. "*Optical information*" means information using optical signals provided by detection system as defined in paragraph 2.1.12. above to enable the driver to detect objects in the area adjacent to the vehicle. This system shall fulfil the provisions of **Annex 13.**
- 2.2. "*Type of device for indirect vision*" means devices that do not differ on the following essential characteristics:
- (a) Design of the device inclusive, if pertinent, the attachment to the bodywork;
  - (b) In the case of mirrors, the class, the shape, the dimensions and radius of curvature of the mirror's reflecting surface;
  - (c) In the case of camera-monitor systems, the class, the field of view, the magnification and resolution.

**2.3. "Surveillance detection system" means....**

**To be described.**

**[OICA PROPOSAL]**

We propose to delete this § 2.3 as we proposed to add §1.5

- 2.4. "Class of device for indirect vision" means all devices having one or more common characteristics or functions. They are classified as follows:

**[OICA COMMENT]**

To check if these definitions are used in the regulation, if not, we should delete them

The intention for remaining Class I to VII is just indication for Class VIII continued from R-46.

- 2.4.1. Class I: "Rear-view device", giving the field of vision fulfilling the provisions of Regulation No. 46, 04 series of amendment paragraph 15.2.4.1.
- 2.4.2. Class II and III: "Main rear-view device", giving the fields of vision fulfilling the provisions of Regulation No. 46, 04 series of amendment paragraph 15.2.4.2. and 15.2.4.3.
- 2.4.3. Class IV: "Wide-angle view device", giving the field of vision fulfilling the provisions of Regulation No. 46, 04 series of amendment paragraph 15.2.4.4.
- 2.4.4. Class V: "Close-proximity view device", giving the field of vision fulfilling the provisions of Regulation No. 46, 04 series of amendment paragraph 15.2.4.5.
- 2.4.5. Class VI: "Front-view device", giving the field of vision fulfilling the provisions of Regulation No. 46, 04 series of amendment paragraph 15.2.4.6.
- 2.4.6. Class VIII: "Close-proximity rear-view device", giving the field of vision defined in paragraph 15.2.4.3. of this regulation.
- 2.5. "Point light source detection factor - *PLSDF*" means the level of distinctness of a pair of point light sources, based on luminance intensities and horizontal and vertical dimension of the rendition on the monitor.
- 2.6. "Point light source contrast factor - *PLSCF*" means the level of distinctness of a pair of point light sources, based on luminance differences between the maximum luminance of the luminance profile  $L_{H,max}$  and the minimum luminance of the luminance profile  $L_{H,min}$  in the horizontal direction (see Figure 3 of Annex 12).

### **3. Application for approval**

- 3.1. The application for approval of a type of device for indirect vision shall be submitted by the holder of the trade name or mark or by his duly accredited representative.
- 3.2. A model of information document is shown in Annex 1.
- 3.3. For each type of device for indirect vision the application shall be accompanied by three samples of the parts.
- 3.4. The CMS shall be provided by the applicant with the following documents:
- (a) Technical specification of the CMS; and

- (b) Operator's manual.

#### **4. Markings**

- 4.1. The samples of devices for indirect vision submitted for approval shall bear the trade name or mark of the manufacturer; this marking shall be clearly legible and be indelible.
- 4.2. Every device for indirect vision shall possess, on at least one of the main components a space large enough to accommodate the approval mark, which shall be legible; this space shall be shown on the drawings referred to in Annex 1. The approval mark shall also be legible when the device is mounted on the vehicle with exception of camera-monitor devices as defined in paragraph 2.1.2. or detection system ~~that provides audible and optical information~~ as defined in paragraph 2.1.12. Other components of the device shall bear a means of identification. In the case of limited space for the approval mark(s), other means of identification that link it to the approval mark shall be provided.

#### **5. Approval**

- 5.1. If the samples submitted for approval meet the requirements of paragraph 6. of this Regulation, approval of the pertinent type of device for indirect vision shall be granted.
- 5.2. An approval number shall be assigned to each type approved. Its first two digits (at present 00) shall indicate the series of amendments incorporating the most recent major technical amendments made to the Regulation at the time of issue of the approval. The same Contracting Party shall not assign the same number to another type of device for indirect vision.
- 5.3. Notice of approval or of refusal or of extension or withdrawal of approval or of production definitively discontinued of a type of device for indirect vision pursuant to this Regulation shall be communicated to the Parties to the Agreement which apply this Regulation by means of a form conforming to the model in Annex 3 to this Regulation.
- 5.4. There shall be affixed, on at least one of the main components, conspicuously and in the space referred to in paragraph 4.2. above, to every device for indirect vision, conforming to a type approved under this Regulation, in addition to the mark prescribed in paragraph 4.1. above, an international approval mark consisting of:
- 5.4.1. A circle surrounding the letter "E" followed by the distinguishing number of the country which has granted approval;<sup>1</sup>
- 5.4.2. An approval number;
- 5.4.3. Additional symbol VIII, specifying the class to which the type of device for indirect vision belongs. The additional symbol shall be placed in any convenient position in the vicinity of the circle containing the letter "E".
-

- 5.5. The approval mark and the additional symbol(s) shall be clearly legible and be indelible.
- 5.6. Annex 5 to this Regulation gives an example of the arrangement of the aforesaid approval mark and additional symbol.

## 6. Requirements

- 6.1. **Class VIII Mirrors**
  - 6.1.1. General specifications
    - 6.1.1.1. All mirrors shall be adjustable.
    - 6.1.1.2. Mirrors installed outside the vehicles shall comply with sub-paragraph (a) ~~above~~ and mirrors installed inside the vehicle shall comply with sub paragraph (b).
      - (a) Outside rear-view mirrors

The edge of the reflecting surface shall be enclosed in a protective housing (holder, etc.) which, on its perimeter, shall have a value "c" greater than or equal to 2.5 mm at all points and in all directions. If the reflecting surface projects beyond the protective housing, the radius of curvature "c" on the edge of the projecting part shall be not less than 2.5 mm and the reflecting surface shall return into the protective housing under a force of 50 N applied to the point of greatest projection, relative to the protective housing, in a horizontal direction, approximately parallel to the longitudinal median plane of the vehicle.
      - (b) Inside rear-view mirrors

In cases, where the edge of the reflecting surface is enclosed in a protective housing (holder, etc.), the radius of curvature "c" on its perimeter shall be not less than 2.5 mm at all points and in all directions. In cases, where the edge of the reflecting surface projects beyond the protective housing, this requirement shall apply to the edge of the projecting part.
    - 6.1.1.3. When the mirror is mounted on a plane surface, all parts, irrespective of the adjustment position of the device, including those parts remaining attached to the support after the test provided for in paragraph 6.3.2. below, which are in potential, static contact with a sphere either:
      - (a) for a mirror installed inside the vehicle: 165 mm in diameter; or
      - (b) for a mirror installed outside the vehicle, 100 mm in diameter;shall have a radius of curvature 'c' of not less than 2.5 mm.
    - 6.1.1.4. The requirements in paragraphs 6.1.1.2. and 6.1.1.3. above shall not apply to parts of the external surface which protrude less than 5 mm, but the outward facing angles of such parts shall be blunted, save where such parts protrude less than 1.5 mm. For determining the dimension of the projection, the following method shall apply:
      - 6.1.1.4.1. The dimension of the projection of a component which is mounted on a convex surface may be determined either directly or by reference to a drawing of an appropriate section of this component in its installed condition.

- 6.1.1.4.2. If the dimension of the projection of a component which is mounted on a surface other than convex cannot be determined by simple measurement, it shall be determined by the maximum variation of the distance of the centre of a 100 mm diameter sphere from the nominal line of the panel when the sphere is moved over and is in constant contact with that component. Figure 1 shows an example of the use of this procedure.

Figure 1

**Example for the measurement by maximum variation**

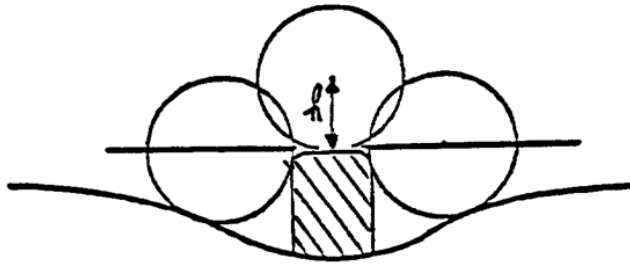

- 6.1.1.5. Edges of fixing holes or recesses of which the diameter or longest diagonal is less than 12 mm are exempt from the radius requirements of paragraph 6.1.1.3. above provided that they are blunted.
- 6.1.1.6. The device for the attachment of mirrors to the vehicle shall be so designed that a cylinder with a 70 mm radius (50 mm in the case of an L-category vehicle), having as its axis the axis, or one of the axes, of pivot or rotation which ensures deflection of the mirror in the direction of impact concerned, passes through at least part of the surface to which the device is attached.
- 6.1.1.7. The parts of Class VIII mirrors installed outside the vehicle referred to in paragraphs 6.1.1.2. and 6.1.1.3. above which are made of a material with a Shore A hardness not exceeding 60 are exempt from the relevant provisions.
- 6.1.1.8. The parts of Class VIII mirrors installed inside the vehicle which are made of a material with a Shore A hardness of less than 50 and which are mounted on a rigid support, the requirements of paragraphs 6.1.1.2. and 6.1.1.3. above shall only apply to the support.
- 6.1.2. Special specifications
- 6.1.2.1. Dimensions
- 6.1.2.1.1. "Close-proximity rear" view mirrors (Class VIII)
- The contours of the reflecting surface shall be of simple geometric form and its dimensions such that the mirror provides the field of vision specified in paragraph 15.2.4.3. of this Regulation.
- 6.1.2.2. Reflecting surface and coefficients of reflection
- 6.1.2.2.1. The reflecting surface of a mirror shall be either flat or spherically convex. Exterior mirrors may be equipped with an additional aspherical part provided that the main mirror fulfils the requirements of the indirect field of vision.



- 
- 6.1.2.2.2. Differences between the radii of curvature of mirrors
- 6.1.2.2.2.1. The difference between  $r_i$  or  $r'_i$ , and  $r_p$  at each reference point shall not exceed 0.15 r.
- 6.1.2.2.2.2. The difference between any of the radii of curvature ( $r_{p1}$ ,  $r_{p2}$ , and  $r_{p3}$ ) and r shall not exceed 0.15 r.
- 6.1.2.2.2.3. When r is not less than 3,000 mm, the value of 0.15 r quoted in paragraphs 6.1.2.2.2.1. and 6.1.2.2.2.2. above is replaced by 0.25 r.
- 6.1.2.2.3. Requirements for aspherical parts of mirrors
- 6.1.2.2.3.1. Aspherical mirrors shall be of sufficient size and shape to provide useful information to the driver. This normally means a minimum width of 30 mm at some point.
- 6.1.2.2.3.2. The radius of curvature  $r_i$  of the aspherical part shall not be less than 150 mm.
- 6.1.2.2.4. The value of the normal coefficient of reflection, as determined according to the method described in Annex 6, shall be not less than 40 per cent.
- In the case of reflecting surfaces with a changeable degree of reflection, the "day" position shall allow the colours of the signals used for road traffic to be recognized. The value of the normal coefficient of reflection in the "night" position shall be not less than 4 per cent.
- 6.1.2.2.5. The reflecting surface shall retain the characteristics laid down in paragraph 6.1.2.2.4. above in spite of prolonged exposure to adverse weather conditions in normal use.
- 6.2. **Class VIII** Devices for indirect vision other than mirrors
- 6.2.1. General requirements
- 6.2.1.1. If adjustment by the user is needed, the device for indirect vision shall be adjustable without the use of tools.
- ~~6.2.1.2. [If a device for indirect vision can only render the total prescribed field of vision by scanning the field of vision, the total process of scanning, rendering and reset to its initial position together shall not take more than 200m seconds.]~~
- ~~6.2.1.2. Scanning process to be amended.~~
- ~~FMVSS started wake-up from door open until 2 seconds to be considered.~~

[OICA COMMENT]

To be discussed in Part II regarding Installation and not in part I of the regulation

- 
- 6.2.1.3. The effectiveness of the CMS and other vision supporting devices of Class VIII shall not be adversely affected by magnetic or electrical fields. This shall be demonstrated by compliance with the technical requirements and transitional provisions of Regulation No. 10, 05 series of amendments or any later series of amendments.
- 6.2.2. Camera-monitor systems
- The requirements of paragraph 6.2.2.1. shall be considered to be satisfied in the case of monitors of a vehicle that fulfills the provisions of Regulation No. 21.
- 6.2.2.1. General requirements
- 6.2.2.1.1. When the devices of the camera-monitor system are mounted in the position recommended by the manufacturer for normal driving, all parts, irrespective of the adjustment position of the device which are in potential, static contact with a sphere either 165 mm in diameter in the case of a CMS or parts of CMS installed inside the vehicle or 100 mm in diameter in the case of a CMS or parts of CMS installed outside the vehicle, shall have a radius of curvature "c" of not less than 2.5 mm.
- 6.2.2.1.2. Edges of fixing holes or recesses of which the diameter or longest diagonal is less than 12 mm are exempt from the radius requirements of paragraph 6.2.2.1.1. above provided that they are blunted.
- 6.2.2.1.3. For parts of the camera and the monitor which are made of a material with a Shore A hardness of less than 60 and which are mounted on a rigid support, the requirements of paragraph 6.2.2.1.1. above shall only apply to the support.
- 6.2.2.2. Functional requirements for camera-monitor devices of Class VIII
- ~~6.2.2.2.1.~~ Deleted (sunlight falls requirement due to not affected for rear view camera)
- 6.2.2.2.1. The monitor shall render a minimum contrast under various light conditions as specified by ISO 15008:2003.
- 6.2.2.2.2. It shall be possible to adjust the average luminance of the monitor either manually or automatically to the ambient conditions.
- 6.2.2.2.3. The measurements for the luminance contrast of the monitor shall be carried out according to ISO 15008:2009.
- 6.2.2.3. System latency
- A CMS shall have a sufficient short latency to render the scenery nearly at the same time. The latency shall be lower than 200 ms at room temperature  $22\text{ }^{\circ}\text{C} \pm 5\text{ }^{\circ}\text{C}$ .

[OICA PROPOSAL]

We propose to delete § 6.2.2.3 and to define only response time (see below in other sections)

- 6.2.3. Other devices for indirect vision
- It has to be proved that the device meets the following requirements:
- 6.2.3.1. The device shall perceive the visual spectrum and shall always render this image without the need for interpretation into the visual spectrum.
- 6.3. Test

The requirements of paragraph 6.3. shall be considered to be satisfied in the case of monitors of a vehicle fulfilling the provisions of Regulation No. 21.

6.3.1. Devices for indirect vision in Class VIII mirrors shall be subjected to the tests described in paragraphs 6.3.2.1. and 6.3.2.2. below.

6.3.1.1. The test provided for in paragraph 6.3.2. below shall not be required in the case of Class VIII exterior device for indirect vision of which no part is less than 2 m from the ground, regardless of the adjustment position, when the vehicle is under a load corresponding to its maximum technically permissible mass.

This derogation also applies to the attachments of devices for indirect vision (attachment plates, arms, swivel joints, etc.) which are situated less than 2 m from the ground and which do not project beyond the overall width of the vehicle, measured in the transverse plane passing through the lowest mirror attachments or any other point forward of this plane if this configuration produces a greater overall width.

In such cases, a description specifying that the device for indirect vision shall be mounted so as to conform to the above-mentioned conditions for the positioning of its attachments on the vehicle shall be provided.

Where advantage is taken of this derogation, the arm shall be indelibly marked with the symbol

$\Delta$   
2m

and the type approval certificate shall be endorsed to this effect.

[OICA PROPOSAL]

6.3.1.1. The test provided for in paragraph 6.3.2. below shall not be required in the case of Class VIII exterior device for indirect vision of which no part is less than 2 m from the ground, regardless of the adjustment position, when the vehicle is under a load corresponding to its maximum technically permissible mass **OR in the case of Class VIII exterior device for indirect vision is installed within the overall width of the vehicle.**

6.3.2. Impact test

The test according to this paragraph is not to be carried out for devices integrated in the bodywork of the vehicle and providing a frontal deflecting area of an angle not more than 45° measured in relation to the longitudinal median plane of the vehicle, or devices not protruding more than 100 mm measured beyond the circumscribing bodywork of the vehicle according to Regulation No. 26, 03 series of amendments.

6.3.2.1. Description of the test rig

6.3.2.1.1. The test rig consists of a pendulum capable of swinging about two horizontal axes at right angles to each other, one of which is perpendicular to the plane containing the "release" trajectory of the pendulum.

The end of the pendulum comprises a hammer formed by a rigid sphere with a diameter of 165 ± 1 mm having a 5 mm thick rubber covering of Shore A hardness 50.

A device is provided which permits determination of the maximum angle assumed by the arm in the plane of release.

A support firmly fixed to the structure of the pendulum serves to hold the specimens in compliance with the impact requirements specified in paragraph 6.1.3.2.2.6. below.

Figure 2 below gives the dimensions (in mm) of the test rig and the special design specifications:

Figure 2

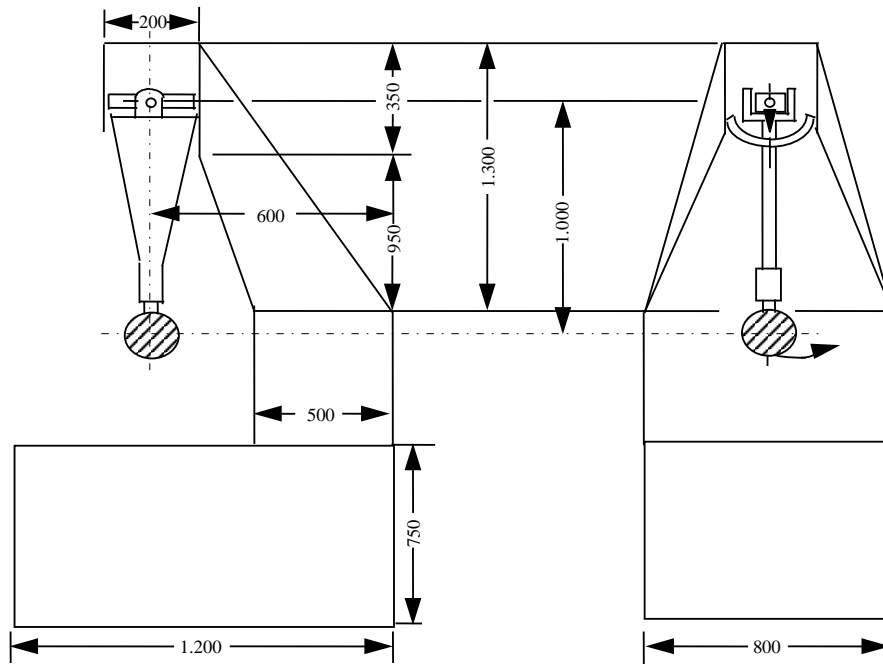

- 6.3.2.1.2. The centre of percussion of the pendulum coincides with the centre of the sphere, which forms the hammer. It is at a distance  $l$  from the axis of oscillation in the release plane, which is equal to  $1\text{ m} \pm 5\text{ mm}$ . The reduced mass of the pendulum is  $m_o = 6.8 \pm 0.05$  kilograms. The relationship of  $m_o$  to the total mass  $m$  of the pendulum and to the distance  $d$  between the centre of gravity of the pendulum and its axis of rotation is expressed in the equation:

$$m_o = m \times \frac{d}{l}$$

- 6.3.2.2. Description of the test
- 6.3.2.2.1. The procedure used to clamp the device for indirect vision to the support shall be that recommended by the manufacturer of the device or, where appropriate, by the vehicle manufacturer.
- 6.3.2.2.2. Positioning of the device for indirect vision for the test
- 6.3.2.2.2.1. Devices for indirect vision shall be positioned on the pendulum impact rig in such a way that the axes which are horizontal and vertical when the mirror is installed on a vehicle in accordance with the applicant's mounting instructions are in a similar position;

- 6.3.2.2.2. When a device for indirect vision is adjustable with respect to the base, the test position shall be that in which any pivoting device is least likely to operate, within the limits of adjustment provided by the applicant;
- 6.3.2.2.3. When the device for indirect vision has a device for adjusting its distance from the base, the device shall be set in the position in which the distance between the housing and the base is shortest;
- 6.3.2.2.4. In the case of mirrors, when the reflecting surface is mobile in the housing, it shall be so adjusted that the upper corner, which is furthest from the vehicle, is in the position of greatest projection relative to the housing.
- 6.3.2.3. In the case of mirrors, when the pendulum is in a vertical position the horizontal and longitudinal vertical planes passing through the centre of the hammer shall pass through the centre of the reflecting surface as defined in paragraph 2.1.1.10. of this Regulation. The longitudinal direction of oscillation of the pendulum shall be parallel to the longitudinal median plane of the vehicle.
- 6.3.2.4. In the case of camera-monitor systems, when the pendulum is in a vertical position the horizontal and longitudinal vertical planes passing through the centre of the hammer shall pass through the centre of the lens or of the transparent protection part protecting the lens. The longitudinal direction of oscillation of the pendulum shall be parallel to the longitudinal median plane of the vehicle. If the test is performed with a shutter camera system, the shutter has to be open during the pendulum impact.
- 6.3.2.5. When, under the conditions governing adjustment laid down in paragraphs 6.3.2.2.1. and 6.3.2.2.2. above parts of the device for indirect vision limit the return of the hammer, the point of impact shall be displaced in a direction perpendicular to the axis of rotation or pivoting in question.
- The displacement shall be no greater than is strictly necessary for the execution of the test; it shall be limited in such a way that:
- (a) Either the sphere delimiting the hammer remains at least tangential to the cylinder as defined in paragraph 6.1.1.6.;
  - (b) Or, in the case of mirrors, the point of contact with the hammer is located at least 10 mm from the periphery of the reflecting surface.
- 6.3.2.6. The test consists in allowing the hammer to fall from a height corresponding to a pendulum angle of 60° from the vertical so that the hammer strikes the device for indirect vision at the moment when the pendulum reaches the vertical position.
- 6.3.2.7. The devices for indirect vision are subjected to impact under the following different conditions:
- 6.3.2.7.1. Classes VIII mirrors
- (a) Test 1: The point of impact shall be as defined in paragraphs 6.3.2.2.3. or 6.3.2.2.5. above. The impact shall be such that the hammer strikes the mirror on the reflecting surface side.
  - (b) Test 2: The point of impact shall be as defined in paragraphs 6.3.2.2.3. or 6.3.2.2.5. above. The impact shall be such that the hammer strikes the mirror on the side opposite to the reflecting surface.

[OICA PROPOSAL]

We propose to delete this § 6.3.2.2.7.1.

6.3.2.2.7.2. Camera-Monitor Systems

- (a) Test 1: The point of impact shall be as defined in paragraphs 6.3.2.2.4. or 6.3.2.2.5. The impact shall be such that the hammer strikes the camera on the lens side.
- (b) Test 2: The point of impact shall be as defined in paragraphs 6.3.2.2.4. or 6.3.2.2.5. The impact shall be such that the hammer strikes the camera on the side opposite to the lens.

Where more than one camera is fixed to the same mounting, the above-mentioned tests shall be executed on the lower camera. Nevertheless, the Technical Service responsible for testing may repeat one or both of these tests on the upper camera if this is less than 2 m from the ground.

[OICA PROPOSAL]

We propose to delete this § 6.3.2.2.7.2.

6.3.3. Results of the tests

- 6.3.3.1. In the tests described in paragraph 6.3.2. above, the pendulum shall continue to swing after impact in such a way that the projection of the position assumed by the arm on the plane of release makes an angle of at least 20° with the vertical. The accuracy of measurement of the angle shall be within  $\pm 1^\circ$ .
- 6.3.3.1.1. In the case of mirrors, this requirement is not applicable to mirrors stuck to the windscreen, in respect of which the requirement stipulated in paragraph 6.3.3.2. shall apply after the test.
- 6.3.3.2. In the case of mirrors, should the mounting of the mirror break during the tests described in paragraph 6.3.2. above for mirrors stuck to the windscreen, the part remaining shall not project beyond the base by more than 10 mm and the configuration remaining after the test shall satisfy the conditions laid down in paragraph 6.1.3. of this Regulation.
- 6.3.3.3. The reflecting surface shall not break during the tests described in paragraph 6.3.2. However, breakage of the reflecting surface will be allowed if one of the following conditions is fulfilled.
  - 6.3.3.3.1. The fragments of glass still adhere to the back of the housing or to a surface firmly attached to the housing; partial separation of the glass from its backing is admissible provided that this does not exceed 2.5 mm on either side of the cracks. It is permissible for small splinters to become detached from the surface of the glass at the point of impact;
  - 6.3.3.3.2. The reflecting surface is made of safety glass.
- 6.3.3.4. In the case of camera-monitor systems, the lens shall not break during the tests described in paragraph 6.3.2. above.

## **7. Modification of the type of device for indirect vision and extension of approval**

7.1. Every modification to an existing type of device for indirect vision including its connection to the bodywork shall be notified to the Type Approval Authority which approved the type of device for indirect vision. The Type Approval Authority shall then either:

- (a) Decide, in consultation with the manufacturer, that a new type-approval is to be granted; or
- (b) Apply the procedure contained in paragraph 7.1.1. (Revision) and, if applicable, the procedure contained in paragraph 7.1.2. (Extension).

### **7.1.1. Revision**

When particulars recorded in the information folder have changed and the Type Approval Authority considers that the modifications made are unlikely to have an appreciable adverse effect and that in any case the device for indirect vision still complies with the requirements, the modification shall be designated a "revision".

In such a case, the Type Approval Authority shall issue the revised pages of the information folder as necessary, marking each revised page to show clearly the nature of the modification and the date of re-issue. A consolidated, updated version of the information folder, accompanied by a detailed description of the modification, shall be deemed to meet this requirement.

### **7.1.2. Extension**

The modification shall be designated an "extension" if, in addition to the change of the particulars recorded in the information folder;

- (a) Further inspections or tests are required; or
- (b) Any information on the communication document (with the exception of its attachments) has changed; or
- (c) Approval to a later series of amendments is requested after its entry into force.

7.2. Confirmation or refusal of approval, specifying the alterations shall be communicated by the procedure specified in paragraph 5.3. above to the Parties to the Agreement which apply this Regulation. In addition, the index to the information package, attached to the communication document, shall be amended accordingly to show the date of the most recent revision or extension.

7.3. The Type Approval Authority issuing the extension of approval shall assign a series number to each communication form drawn up for such an extension.

## **8. Conformity of production**

8.1. The conformity of production procedure shall comply with those set out in the Agreement, Appendix 2 (E/ECE/324-E/ECE/TRANS/505/Rev.2).

- 8.2. Every device for indirect vision approved under this Regulation shall be so manufactured as to conform to the type approved by meeting the requirements set out in paragraph 6. above.

## **9. Penalties for non-conformity of production**

- 9.1. The approval granted in respect of a type of device for indirect vision pursuant to this Regulation may be withdrawn if the requirement laid down in paragraph 8.1. above is not complied with or if the type of device for indirect vision did not satisfy the requirements prescribed in paragraph 8.2. above.
- 9.2. If a Contracting Party to the Agreement which applies this Regulation withdraws an approval it has previously granted, it shall forthwith so notify the other Contracting Parties applying this Regulation by means of a copy of the communication form bearing at the end, in large letters, the signed and dated annotation "APPROVAL WITHDRAWN".

## **10. Production definitively discontinued**

If the holder of the approval completely ceases to manufacture a type of device for indirect vision approved in accordance with this Regulation, he shall so inform the Type Approval Authority which granted the approval. Upon receiving the relevant communication, the Authority shall inform thereof the other Parties to the Agreement applying this Regulation by means of a copy of the approval form bearing at the end, in large letters, the signed and dated annotation "PRODUCTION DISCONTINUED".

## **11. Names and addresses of Technical Services responsible for conducting approval tests, and of Type Approval Authorities**

The Contracting Parties to the Agreement applying this Regulation shall communicate to the United Nations Secretariat the names and addresses of the Technical Services responsible for conducting approval tests and of the Type Approval Authorities which grant approval and to which forms certifying approval or refusal or extension or withdrawal of approval, issued in other countries, are to be sent.



## II. Installation of devices for indirect vision

### 12. Definitions

For the purpose of this Regulation:

- 12.1. "The driver's ocular points" means two points 65 mm apart and 635 mm vertically above point R of the driver's seat as defined in Annex 8. The straight line joining these points runs perpendicular to the vertical longitudinal median plane of the vehicle. The centre of the segment joining the two ocular points is in a vertical longitudinal plane which shall pass through the centre of the driver's designated seating position, as specified by the vehicle manufacturer.
- 12.2. "Ambinocular vision" means the total field of vision obtained by the superimposition of the monocular fields of the right eye and the left eye (see Figure 3 below).

Figure 3

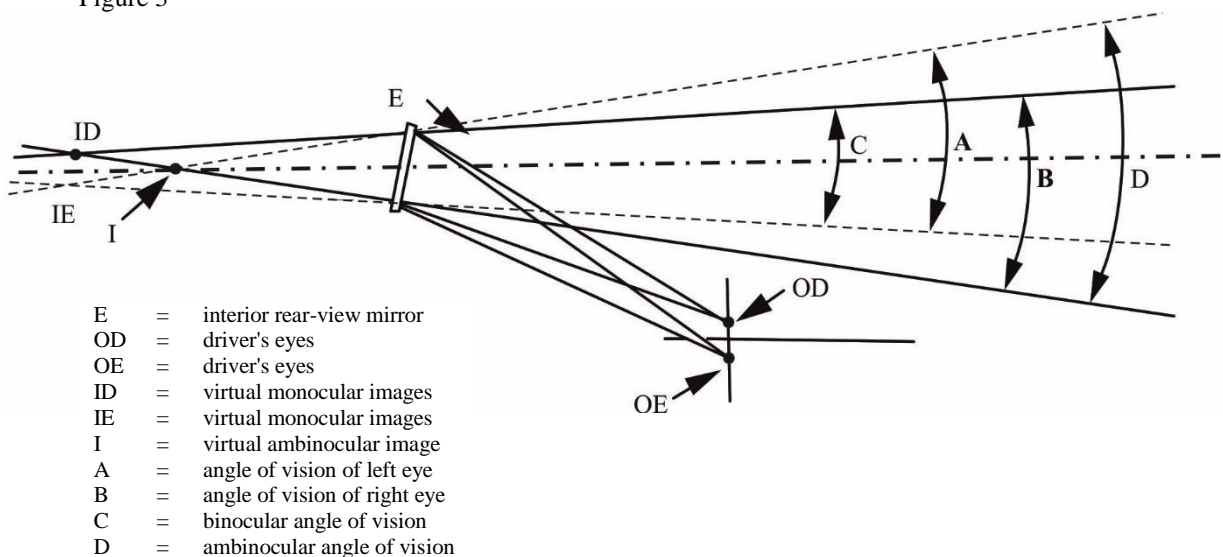

- 12.3. "Type of vehicle as regards indirect vision" means motor vehicles which are identical in respect of the following basic features:
- 12.3.1. Type of device for indirect vision;
- 12.3.2. The bodywork features which reduce the field of vision;
- 12.3.3. The coordinates of point R (where applicable);
- 12.3.4. The prescribed positions, and type-approval markings of compulsory and (if fitted) optional devices for indirect vision.
- 12.4. "Vehicles of categories  $M_1$ ,  $M_2$ ,  $M_3$ ,  $N_1$ ,  $N_2$  and  $N_3$ " means those defined in the Consolidated Resolution on the Construction of Vehicles (R.E.3), (document ECE/TRANS/WP.29/78/Rev.4, para. 2).
- 12.5. "Forward control" means a configuration in which more than half of the engine length is rearward of the foremost point of the windshield base and the steering wheel hub in the forward quarter of the vehicle length.

- 12.6. "Ocular reference point" means the middle point between the driver's ocular points.
- 12.7. "Backing event" means an amount of time which starts when the vehicle's direction selector is placed in reverse **by driver or system**, and ends at the manufacturer's choosing, when the vehicle forward motion reaches:
- (a) a speed of 16 km/h,
  - (b) a distance of 10 meters traveled, or
  - (c) a continuous duration of 10 seconds.
  - (d) the vehicle's direction selector is not placed in reverse.**

### **13. Application for approval**

- 13.1. The application for approval of a vehicle type with regard to the installation of devices for indirect vision shall be submitted by the vehicle manufacturer or by his duly accredited representative.
- 13.2. A model of information document is shown in Annex 2.
- 13.3. A vehicle representative of the vehicle type to be approved shall be submitted to the Technical Service responsible for conducting the approval tests.
- 13.4. The Type Approval Authority shall verify the existence of satisfactory arrangements for ensuring effective checks on conformity of production before type-approval is granted.
- 13.5. The CMS shall be provided by the applicant with the following documents:
- (a) Technical specification of the CMS;
  - (b) Operator's manual;
  - (c) Documentation referred to in Annex 12, paragraph 2.3.

### **14. Approval**

- 14.1. If the vehicle type submitted for approval in accordance with paragraph 13. above meets the requirements of paragraph 15. of this Regulation, approval shall be granted.
- 14.2. An approval number shall be assigned to each type approved. Its first two digits (at present 00) shall indicate the series of amendments incorporating the most recent or technical amendments made to the Regulation at the time of issue of the approval. The same Contracting Party shall not assign the same number to another vehicle type.
- 14.3. Notice of approval or of refusal or of extension or withdrawal of approval of a vehicle type pursuant to this Regulation shall be communicated to the Parties to the Agreement which apply this Regulation by means of a form conforming to the model in Annex 4 to this Regulation.

## 15. Requirements

### 15.1. General

15.1.1. Devices for indirect vision shall be fitted in such a way that the devices do not move so as significantly to change the field of vision as measured or vibrate to an extent which would cause the driver to misinterpret the nature of the image perceived.

15.1.2. The fields of vision defined below shall be established using ambinocular vision, the eyes being at the "driver's ocular points" as defined in paragraph 12.1. above. The fields of vision shall be determined when the vehicle is in running order as defined in the consolidated Resolution on the Construction of vehicles (R.E.3) (ECE/TRANS/WP.29/78/Rev.4, para. 2.2.5.4.), plus for M<sub>1</sub> and N<sub>1</sub> vehicles one front seat passenger (75 kg). When established through windows, the glazing shall have a total light transmission factor in accordance with Regulation No. 43, Annex 21.

### 15.2. Devices for indirect vision

#### 15.2.1. Number

##### 15.2.1.1. Minimum number of compulsory devices for indirect vision

15.2.1.1.1. The fields of vision prescribed in paragraph 15.2.3. shall be obtained from the minimum number of mirrors or camera-monitor device.

A minimum number of camera-monitor systems is undefined, but they shall provide the same field of vision and the provision on the minimum mounting height does not apply.

##### 15.2.1.1.2. Deleted (To be include chapter 16)

15.2.1.2. The provisions of this Regulation do not apply to the surveillance mirrors defined in paragraph 2.1.1.3. of this Regulation. Nevertheless, the exterior surveillance mirrors shall be mounted at least 2 m above the ground when the vehicle is under a load corresponding to its maximum technical permissible mass.

#### 15.2.2. Position

15.2.2.1. Devices for indirect vision shall be so placed that the driver, when sitting on the driving seat in a normal driving position, has a clear view of the road to the rear, side(s) or front of the vehicle.

15.2.2.2. Class VIII mirrors shall be visible through the window(s) or through the portion of the windscreen that is swept by the windscreen wiper. Nevertheless, for design reasons, this last provision (i.e. the provisions relating the cleaned part of the windscreen) shall not apply to Class VIII mirrors.

15.2.2.3. In the case of any vehicle, which is in chassis/cab form when the field of vision is measured, the minimum and maximum body widths shall be stated by the manufacturer and, if necessary, simulated by dummy headboards. All vehicles and devices for indirect vision configurations taken into consideration during the tests shall be shown on the type-approval certificate for a vehicle with regard to the installation of devices for indirect vision (see Annex 4).

- 15.2.2.4. Devices for indirect vision shall not project beyond the external bodywork of the vehicle substantially more than is necessary to comply with the requirements concerning fields of vision laid down in paragraph 15.2.4. below.
- 15.2.3. Fields of vision
- 15.2.3.1. Class VIII close-proximity rear-view device
- 15.2.3.1.1. The field of vision shall be bounded by the following planes and shall be such that the driver can see **the conditions defined in Annex 12**. In this regulation with a height of 1,000 mm and a diameter of 300 mm which is located on the ground plane at nine positions within the boundaries of the field of vision as defined in Figure 3 below:
- (a) A transverse vertical plane through **300 mm distance** from the outermost point of the rear of the vehicle;
  - (b) A transverse vertical plane 3,500 mm behind the outermost point of the rear of the vehicle;
  - (c) Two longitudinal vertical planes parallel to the longitudinal vertical median plane going through the outermost point of each side of the vehicle.
- 15.2.3.1.2. If the field of vision defined in paragraph 15.2.3.1.1. can be perceived via a combination of devices for indirect vision of other Class(es) of devices for indirect vision, it is not mandatory to equip the vehicle with a Class VIII close-proximity rear-view device.
- In addition, the requirement may be met using a combination of mirrors of Class VIII and other Class(es) fulfilling the provisions of Regulation No. 46, 04 series of amendment or using an detection system defined in 2.1.12. of this regulation.
- 15.2.3.1.3.** The vehicles that satisfied the conditions of exemption described below, the field of vision defined in paragraph 15.2.3.1.1. can be perceived via directly from the driver's looking back ocular points described in paragraph 15.2.3.1.4., it is not mandatory to equip the vehicle with a Class VIII close-proximity rear-view device.
- If the field of vision defined in paragraph 15.2.3.1.1. can be perceived directly by the driver, the vertical position of rear seat headrests should be set at [the designed position assumed to use or the highest position if the headrest has multiple position settings or agreed position with the Technical Service].

**Direct vision exemption to be proposed by OICA.**

Figure 3  
Class VIII field of vision

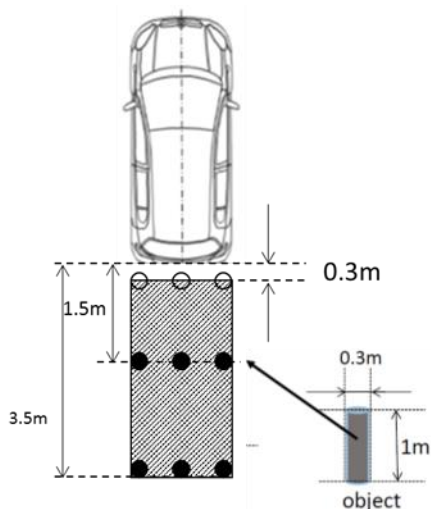

[OICA PROPOSAL]

- 15.2.3.1.2. If the field of vision defined in paragraph 15.2.3.1.1. can be perceived via a combination of devices for indirect vision of other Classes of devices for indirect vision, it is not mandatory to equip the vehicle with a Class VIII close-proximity rear-view device.

In addition, the requirement may be met using a combination of mirrors of Class VIII and other Class(es) fulfilling the provisions of Regulation No. 46, 04 series of amendment or using an detection system defined in 2.1.12. of this regulation.

~~The vehicles that satisfied the conditions of exemption described below, If the field of vision defined in paragraph 15.2.3.1.1. can be **fully** perceived via **direct** view ~~directly~~ from the driver's looking back ocular points described in paragraph 15.2.3.1.3., it is not mandatory to equip the vehicle with a **reversing safety device according to this regulation.** ~~Class VIII close-proximity rear view device.~~~~

**This requirement is also fulfilled if the vehicle is equipped with a Class VIII close proximity rear view mirror installed at the rear end of the vehicle supporting this direct view.**

~~—————The conditions of exemption for direct vision are;~~

~~—————**Direct vision exemption for further discussion in IWC to be described.**~~

If the field of vision defined in paragraph 15.2.3.1.1. can be perceived directly by the driver, the vertical position of rear seat headrests should be set at [the designed position assumed to use or the highest position if the headrest has multiple position settings or agreed position with the Technical Service].

- 15.2.3.1.4. *"The driver's looking back ocular points"* means two points located at 96 mm longitudinally rearward, 158 mm horizontally inside vehicle centre and 6 mm vertically above from "the driver's ocular points" described in paragraph 12.1.

- 15.2.3.1.5. Each transverse row of cylindrical objects should be perceived by one device.

15.2.4.2. In the case of mirrors consisting of several reflecting surfaces which are either of different curvature or make an angle with each other, at least one of the reflecting surfaces shall provide the field of vision and have the dimensions (paragraph 6.1.2.1.2.2. of this Regulation) specified for the class to which they belong.

15.2.4.3. Obstructions

[OICA comments]

15.2.4.3.1. Classes VIII devices for indirect vision and Class VIII mirrors

In the fields of vision specified above, obstruction due to the bodywork and its components, such as other cab devices for indirect vision, door handles, outline marker lights, direction indicators and front and rear bumpers, as well as reflective-surface cleaning components, shall not be taken into account if they are responsible for a total obstruction of less than 10 per cent of the specified field of vision. In the case of a vehicle designed and constructed for special purposes where, due to its special features, it is not possible to meet this requirement, the obstruction of the required field of vision of a Class VIII mirror caused by the special features may be more than 10 per cent but not more than necessary for its special function.

15.2.4.4. Test procedure

The field of vision shall be determined by placing powerful light sources at the ocular points and examining the light reflected on the vertical monitoring screen. Other equivalent methods may be used.

## **16. Requirements for devices for indirect vision other than mirrors**

16.1. Intended use, activation and deactivation

The intended use shall be mentioned within the operator's manual. The procedure for activation and deactivation of the CMS of Class VIII shall allow a safe use of the vehicle.

Notwithstanding the provisions above, any other concept to activate or deactivate the system shall be demonstrated to the satisfaction of the Technical Service within the safety concept that is provided according to the provisions of Regulation No. 46, 04 series of amendment.

16.1.1.1. Default view

In default view the CMS shall show the field of view at least as defined in paragraph 15.2.3., with at least the required magnification and resolution as defined in paragraph 16.1.3.

The rear view CMS system must default to the rearview image at the beginning of each backing event regardless of any modifications to the field of view the driver has previously selected.

16.1.1.2. Luminance and contrast adjustment

If manual adjustment is provided, the operator's manual shall provide information on how to change the luminance/contrast.

- 
- 16.1.1.3. Overlay requirements within the minimum required field of vision  
Overlays shall display only rearward driving-related visual information.  
Only safety related information overlays are allowed.  
Overlays for other purposes of information shall be considered as an obstruction regardless of their transparency.
- 16.1.1.4. Deactivation  
The rearview image shall remain visible during the backing event until either, the driver modifies the view, or the vehicle direction selector is removed from the reverse position.

[OICA COMMENT]

FMVSS 111 – TP

F. DEACTIVATION (S5.5.5, S6.2.5) (Data Sheet 13)

REQUIREMENT:

The rearview image meeting the requirements of S5.5.1 and S5.5.2 (S6.2.1 and S6.2.2) shall remain visible during the backing event until either:

- the driver modifies the view, or
- the vehicle direction selector is removed from the reverse position.

This test is conducted to verify that once the backing event is initiated (transmission selector into reverse gear), the rearview image cannot be extinguished by any means other than driver intervention which would include the vehicle direction selector being removed from the reverse position. Rearview image must extinguish by end of backing event.

[OICA PROPOSAL]

- 16.1.1.5 Automatic change of view  
When there is a risk of collision, the FoV may change and focus on the collision area. It should be demonstrated to the Technical service that this CoV increases the safety  
When the vehicle is not driving straight, the FoV may change following the vehicle trajectory.
- 16.1.1.6. Automatic screen change  
The default view may be automatically changed, in case of:  
- system failure or,  
- Information needed to be shown to the driver for safety reasons (for instance automatic ecall message)
- 16.1.2. Operating readiness (System availability)  
Non-operation of the system shall be recognizable to the driver is (e.g. CMS failure by, i.e. warning indication, display information, absence of status indicator). The information for the driver shall be explained in the operator's manual.

[OICA PROPOSAL]

- 16.1.2.1. Response time.  
The rearview image meeting the requirements of xxx and xxxx, shall be displayed within 2.0 seconds when the backing event starts.

16.1.3. Resolution

16.1.3.1. Resolution (MTF)

The resolution (MTF) defines the minimum distinguishable details observable in an image as is represented by the MTF10. For reasons of simplicity the requirement is defined assuming an aspect ratio of 1:1.

Resolution MTF10, at the centre of the monitor defined size shall fulfil the following requirements:

$$MTF10_{(1:1)/hor} \geq MTF10_{MIN(1:1)/hor}, \quad \text{in horizontal direction, } -0,34 \leq 1 - \frac{M_{system/hor/avg}}{M_{system/ver/avg}} \leq$$

$$MTF10_{(1:1)/ver} \geq MTF10_{MIN(1:1)/ver}, \quad \text{in vertical direction, } -0,34 \leq 1 - \frac{M_{system/hor/avg}}{M_{system/ver/avg}} \leq$$

Resolution MTF10, at the corner measurement points as illustrated in the figure below shall fulfil the following requirements:

$$MTF10_{(1:1)/hor} \geq \frac{1}{2} MTF10_{MIN(1:1)/hor}, \quad \text{in horizontal direction, } -0,34 \leq 1 - \frac{M_{system/hor/avg}}{M_{system/ver/avg}} \leq$$

$$MTF10_{(1:1)/ver} \geq \frac{1}{2} MTF10_{MIN(1:1)/ver}, \quad \text{in vertical direction, } -0,34 \leq 1 - \frac{M_{system/hor/avg}}{M_{system/ver/avg}} \leq$$

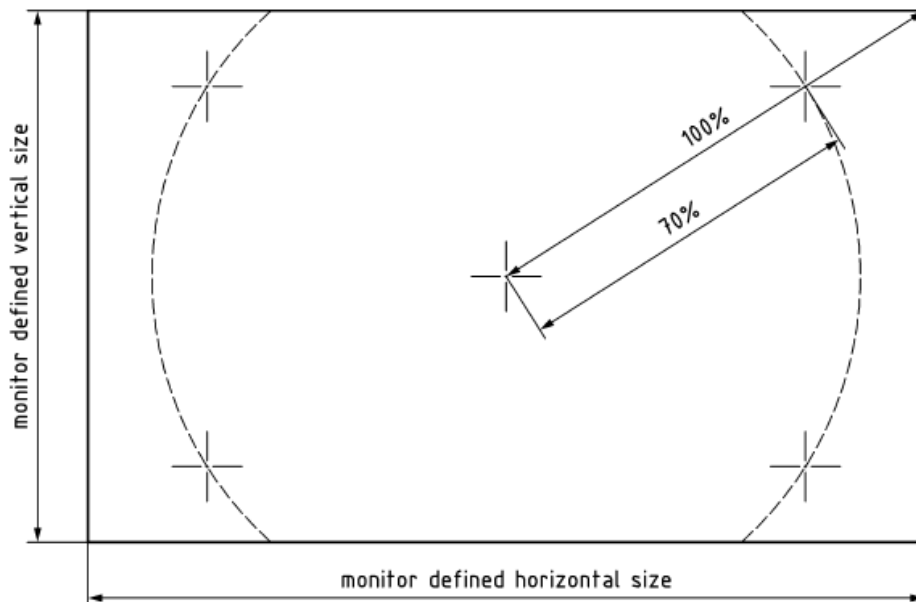

16.1.4. Monitor inside the vehicle



- 16.1.4.1. The centre of the monitor(s) shall not be below a plane passing through the driver's ocular points, as defined in paragraph 12.1., and declined 30° below.
- 16.1.4.2. The arrangement of the monitor(s) inside the vehicle shall be convenient to the driver.
- Thus, the image of the right side field of view shall be presented to the right of the longitudinal vertical plane through the ocular reference point, defined in paragraph 12.6. The image of the left side field of view shall be presented to the left of the longitudinal vertical plane through the ocular reference point.
- If the CMS shows more than one field of vision on one display, non-continuous images shall be clearly separated from each other. Provided that the required field of vision of different classes of devices for indirect vision are shown on the monitor(s) without hiding any part of the required field of vision, a combined continuous image without clear separation is allowed.
- 16.1.4.3. The monitor defined size shall be visible without any obstruction from the ocular reference point. A virtual testing is acceptable.
- 16.1.5. Obstruction of the driver's direct view caused by the installation of a device for indirect vision shall be restricted to a minimum.
- 16.1.6. Decreasing accommodation
- The installation of the monitor inside the vehicle should follow the needs of the intended user group. The operator's manual shall provide information on the decreasing capacity of the human being to accommodate and shall recommend suitable assistance for the user's needs.
- 16.1.7. Safety of electronic systems for indirect vision
- The requirements to be applied to the safety aspects of electronic systems for indirect vision are given in Annex 12, paragraph 2.
- 16.2. Classes VIII camera-monitor devices
- 16.2.1. A device for indirect vision shall give such performances that a critical object can be observed by the driver over the entire required field of vision, taking into account the critical perception according the procedure of Annex 10.
- Alternatively, the determination of the displayed object size shall be performed according to Annex 11.
- 16.2.2. Obstruction of the driver's direct view caused by the installation of a device for indirect vision shall be restricted to a minimum.
- 16.2.3. Installation requirements for the monitor
- The viewing direction of the monitor shall roughly be the same direction as the one for the main mirror.
- 16.2.4. Vehicles may be equipped with additional devices for indirect vision.
- 16.2.5. The provisions of this Regulation do not apply to the surveillance camera-monitor-recording devices defined in paragraph 2.3. of this Regulation. Exterior surveillance cameras either shall be mounted at least 2 m above the ground when the vehicle is under a load corresponding to its maximum technical permissible mass, or, if their lower edge is less than 2 m from the ground, shall not project more than 50 mm beyond the overall width of the

vehicle measured without this device and have a radii of curvature of not less than 2.5 mm.

## **17. Requirements for detection systems**

New (Moved from original Annex 14)

### 17.1. System activation

The system shall be activated when the reverse gear is selected. If proper functioning cannot be effected, either the system shall automatically shut off or the driver shall be able to deactivate the system manually.

There may be an on/off switch or push-button to override automatic (de)activation by driver. In the case, vehicle can detect coupling with towing vehicles, automatic off function can be activated.

### 17.2. Driver interface and information presentation strategy

#### 17.2.1. Audible information

When an object is detected in the rear horizontal area as described in paragraph 2.1. of Annex 13., audible information in accordance with ISO 15006:2010 shall be given.

In presenting audible information, the distance may be identified at two or more levels. These zones may be indicated by changing the frequency of intermittent sound, and faster intermittent sound or continuous sound shall be used as the distance becomes closer.

#### 17.2.2. Duration of signaling

Signaling for an object shall last as long as the object is detected and shall end when the object is no longer detected or when the system is deactivated.

To reduce the driver's discomfort, the audible signal can be automatically suspended temporarily after a certain time set by the manufacturer has elapsed, provided that the system remains to be activated. If, while the audible signal is automatically suspended temporarily, the distance to the object becomes short, the audible signal shall be automatically resumed. If the distance to the object becomes long, the audible signal may remain suspended.

### 17.3. General test conditions

The test object shall be as per paragraph 7.1. of ISO 17386:2010. During testing, the wind speed shall not exceed 1 m/s. The temperature shall be  $20 \pm 5^\circ\text{C}$  and the humidity shall be  $60 \pm 25$  percent. There shall be no rain or snow. The test shall be performed on a flat, dry asphalt or concrete surface. The test shall not be affected by the reflection of sound waves or electromagnetic waves from any walls, auxiliary testing equipment or any other objects in the environment.

### 17.4. Dynamic performance of object detection

#### 17.4.1. Detection latency

The detection latency as measured according to paragraph 2.2. of Annex 13. shall not exceed 0.6 s.

[OICA PROPOSAL]

- 17.4.2      **Response time.**  
The signal meeting the requirements of xxx and xxxx, shall be given to the driver within 2.0 seconds when the backing event starts.

## **18.      Modifications of the vehicle type and extension of approval**

- 18.1.      Every modification of the vehicle type shall be notified to the Type Approval Authority which approved the vehicle type. Type Approval Authority shall then either:

- (a)      Decide, in consultation with the manufacturer, that a new type approval is to be granted; or
- (b)      Apply the procedure contained in paragraph 17.1.1. (Revision) and, if applicable, the procedure contained in paragraph 17.1.2. (Extension).

18.1.1.      **Revision**

When particulars recorded in the information folder have changed and the Type Approval Authority considers that the modifications made are unlikely to have an appreciable adverse effect, and that in any case the vehicle still complies with the requirements, the modification shall be designated a "revision".

In such a case, the Type Approval Authority shall issue the revised pages of the information folder as necessary, marking each revised page to show clearly the nature of the modification and the date of re-issue. A consolidated , updated version of the information folder, accompanied by a detailed description of the modification, shall be deemed to meet this requirement.

18.1.2.      **Extension**

The modification shall be designated an "extension" if, in addition to the change of the particulars recorded in the information folder,

- (a)      Further inspections or tests are required; or
- (b)      Any information on the communication document (with the exception of its attachments) has changed; or
- (c)      Approval to a later series of amendments is requested after its entry into force.

- 18.2.      Confirmation or refusal of approval, specifying the alterations, shall be communicated to the Parties to the Agreement which apply this Regulation by means of a form conforming to the model in Annex 4 to this Regulation. In addition, the index to the information package, attached to the communication document, shall be amended accordingly to show the date of the most recent revision or extension.

- 18.3.      The Type Approval Authority issuing the extension of approval shall assign a series number to each communication form drawn up for such an extension.

## **19. Conformity of production**

- 19.1. The conformity of production procedure shall comply with those set out in the Agreement, Appendix 2, (E/ECE/324-E/ECE/TRANS/505/Rev.2).
- 19.2. Every vehicle approved under this Regulation shall be so manufactured as to conform to the type approved by meeting the requirements set out in paragraph 15., and where applicable paragraph 16. above.

## **20. Penalties for non-conformity of production**

- 20.1. The approval granted in respect of a vehicle type pursuant to this Regulation may be withdrawn if the requirement laid down in paragraph 18.1. above is not complied with or if the vehicle fails to pass the checks prescribed in paragraph 18.2. above.
- 20.2. If a Party to the Agreement which applies this Regulation withdraws an approval it has previously granted, it shall forthwith so notify the other Contracting Parties applying this Regulation by means of a copy of the approval form bearing at the end, in large letters, the signed and dated annotation "APPROVAL WITHDRAWN".

## **21. Production definitively discontinued**

If the holder of the approval completely ceases to manufacture a type of vehicle approved in accordance with this Regulation, he shall so inform the Type Approval Authority which granted the approval. Upon receiving the relevant communication, the Authority shall inform thereof the other Parties to the Agreement applying this Regulation by means of a copy of the approval form bearing at the end, in large letters, the signed and dated annotation "PRODUCTION DISCONTINUED".

## **22. Names and addresses of Technical Services responsible for conducting approval tests, and of Type Approval Authorities**

The Parties to the Agreement applying this Regulation shall communicate to the United Nations Secretariat the names and addresses of the Technical Services responsible for conducting approval tests and of the Type Approval Authorities which grant approval and to which forms certifying approval or refusal or extension or withdrawal of approval, issued in other countries, are to be sent.

---

## Annex 1

### **Information document for type approval of a device for indirect vision**

The following information, if applicable, shall be supplied in triplicate and shall include a list of contents.

Any drawings shall be supplied in appropriate scale and in sufficient detail on size A4 paper or on a folder of A4 format.

Photographs, if any, shall show sufficient details.

1. Make (trade name of manufacturer): .....
2. Type and general commercial description(s): .....
3. Means of identification of the type, if indicated on the device: .....
4. Category of vehicle for which the device is intended: .....
5. Name and address of manufacturer: .....
6. Location and method of affixing of the approval mark: .....
- 6.1. Other mean of identification link to the approval mark: .....
7. Address(es) of assembly plant(s): .....
8. Mirrors (state for each mirror): .....
- 8.1. Variant .....
- 8.2. Drawing(s) for the identification of the mirror: .....
- 8.3. Details of the method of attachment: .....
9. Devices for indirect vision other than mirrors: .....
- 9.1. Type and characteristics (such as a complete description of the device): .....
- 9.1.1. In the case of camera-monitor systems of Class VIII, the class, the detection distance [mm], contrast, luminance range, glare correction, display performance (black and white/colour) image repetition frequency, luminance reach of the monitor: .....
- 9.1.2. In the case of detection system of Classes VIII, the class, field of view, latency and rear horizontal area and detection rate: .....
- 9.2. Sufficiently detailed drawings to identify the complete device including installation instructions; the position for the type-approval mark has to be indicated on the drawings: .....

## Annex 2

### Need to modify for application of detection system.

#### Information document for type approval of a vehicle with respect to the installation of devices for indirect vision

The following information, if applicable, shall be supplied in triplicate and include a list of contents.

Any drawings shall be supplied in appropriate scale and in sufficient detail on size A4 paper or on a folder of A4 format.

Photographs, if any, shall show sufficient details.

##### General

1. Make (trade name of manufacturer): .....
2. Type and general commercial description(s): .....
3. Means of identification of type, if marked on the vehicle: .....
4. Location of that marking: .....
5. Category of vehicle: .....
6. Name and address of manufacturer: .....
7. Address(es) of assembly plant(s): .....

##### General construction characteristics of the vehicle

8. Photograph(s) and/or drawing(s) of a representative vehicle: .....
9. Driving cab (forward control or bonneted):<sup>1</sup> .....
10. Driving position: left/right<sup>1</sup> .....
- 10.1. The vehicle is equipped to be driven in right-hand/left hand traffic<sup>1</sup> .....
11. Range of vehicle dimensions (overall): .....
- 11.1 For chassis without bodywork .....
- 11.1.1. Width:<sup>2</sup> .....

<sup>1</sup> Strike out where not applicable

<sup>2</sup> "Overall width" of a vehicle means a dimension which is measured according to ISO standard 612-1978, term No. 6.2. In the case of vehicles of category other than M<sub>1</sub>, in addition to the provisions of that standard, when measuring the vehicle width the following devices shall not be taken into account:

- (a) Customs sealing devices and their protection;
- (b) Devices for securing the tarpaulin and their protection;
- (c) Tyre failure tell-tale devices;
- (d) Protruding flexible parts of a spray-suppression system;
- (e) Lighting equipment;
- (f) For buses, access ramps in running order, lifting platforms and similar equipment in running order provided that they do not exceed 10 mm from the side of the vehicle and the corners of the ramps facing forwards or rearwards are rounded to a radius of not less than 5 mm; the edges shall be rounded to a radius of not less than 2.5 mm;
- (g) Devices for indirect vision;

---

11.1.1.1.	Maximum permissible width: .....
11.1.1.2.	Minimum permissible width: .....
11.2.	For chassis with bodywork: .....
11.2.1.	Width <sup>2</sup> .....
12.	Bodywork
12.1.	Devices for indirect vision
12.1.1.	Mirrors .....
12.1.1.1.	Drawing(s) showing the position of the mirror relative to the vehicle structure: .....
12.1.1.2.	Details of the method of attachment including that part of the vehicle structure to which it is attached: .....
12.1.1.3.	Optional equipment which may affect the rearward field of vision: .....
12.1.1.4.	A brief description of the electronic components (if any) of the adjustment device: .....
12.1.2.	Devices for indirect vision other than mirrors: .....
12.1.2.1.	Sufficiently detailed drawings with the installation instructions: .....
12.1.2.2.	In the case of camera-monitor system of Classes VIII: .....
12.1.2.2.1.	Drawing(s)/photograph(s) showing the position of the camera(s) relative to the vehicle structure: .....
12.1.2.2.2.	Drawing(s)/photograph(s) showing the arrangement of the monitor(s) including surrounding interior parts: .....
12.1.2.2.3.	Drawing(s)/photograph(s) showing the drivers view onto the monitor(s): .....
12.1.2.2.4.	Drawing(s)/photograph(s) showing the setup and monitor image of the required field of view: .....
12.1.2.2.5.	Details of the method of attachment of the camera-monitor device(s) including that part of the vehicle structure to which it is attached: .....
12.1.2.2.6.	Optional equipment which may affect the rearward field of vision: .....
12.1.2.2.7.	A brief description of the electronic components (if any) of the adjustment device: .....
12.1.2.2.8.	A technical specification and operator's manual of the camera-monitor system according to ISO 16505:2015: .....

- 
- (h) Tyre-pressure indicators;
  - (i) Retractable steps;
  - (j) The deflected part of the tyre walls immediately above the point of contact with the ground.

### Annex 3

#### Need to modify for application of detection system.

### Communication

(Maximum format: A4 (210 x 297 mm))

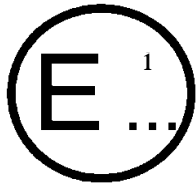

issued by:

Name of administration:

.....  
.....  
.....

<sup>1</sup>

Concerning:<sup>2</sup>

- Approval granted
- Approval extended
- Approval refused
- Approval withdrawn
- Production definitively discontinued

of a type of device for indirect vision pursuant to Regulation No. 46

Approval No. .... Extension No. ....

1. Trade name or mark of device: .....
  2. Manufacturer's name for the type of device: .....
  3. Manufacturer's name and address: .....
  4. If applicable, name and address of manufacturer's representative: .....
  5. Submitted for approval on: .....
  6. Technical Service responsible for conducting approval tests: .....
  7. Date of report issued by that Service .....
  8. Number of report issued by that Service .....
  9. Brief description .....
- Identification of the device: mirror, camera/monitor, other device<sup>2</sup>
- Device for indirect vision of Classes VIII <sup>2</sup>
- Symbol  $\frac{\Delta}{2m}$  as defined in paragraph 6.3.1.1. of this Regulation: yes/no<sup>2</sup>
10. Position of the approval mark: .....
  11. Reason(s) for extension (if applicable): .....
  12. Approval granted/refused/extended/withdrawn:<sup>2</sup>

<sup>1</sup> Distinguishing number of the country which has granted/extended/refused/withdrawn approval (see approval provisions in the Regulations).

<sup>2</sup> Strike out what does not apply.



- 13. Place:.....
- 14. Date:.....
- 15. Signature: .....
- 16. The list of documents deposited with the Type Approval Authority which has granted approval is annexed to this communication and may be obtained on request.

## Annex 4

### Communication

(Maximum format: A4 (210 x 297 mm))



issued by :

Name of administration:

.....  
.....  
.....

1

Concerning:<sup>2</sup>      Approval granted  
                         Approval extended  
                         Approval refused  
                         Approval withdrawn  
                         Production definitively discontinued

of a type of vehicle with regard to the mounting of devices for indirect vision pursuant to Regulation No. 46

Approval number: .....      Extension No.: .....

1.    Make (trade name of manufacturer): .....
2.    Type and general commercial description(s) .....
3.    Means of identification of type, if marked on the vehicle:.....
- 3.1. Location of that marking:.....
4.    Category of vehicle: (M<sub>1</sub>, M<sub>2</sub>, M<sub>3</sub>, N<sub>1</sub>, N<sub>2</sub> ≤ 7.5 t, N<sub>2</sub> > 7.5 t, N<sub>3</sub>)<sup>2</sup>
5.    Name and address of manufacturer: .....
6.    Address(es) of the production plant(s) .....
7.    Additional information: (where applicable). See appendix
8.    Technical Service responsible for carrying out the tests: .....
9.    Date of test report: .....
10.   Number of test report: .....
11.   Remarks: (if any). See appendix
12.   Place:.....
13.   Date:.....
14.   Signature: .....

<sup>1</sup> Distinguishing number of the country which has granted/extended/refused/withdrawn approval (see approval provisions in the Regulation).

<sup>2</sup> Strike out what does not apply.

15. The index to the information package lodged with the Type Approval Authority, which may be obtained on request is attached.

## Annex 4 – Appendix

Appendix to type approval communication form No. .... concerning the type approval of a vehicle with regard to the mounting of devices for indirect vision under Regulation No. XXX.

1. Trade name or mark of mirrors and supplementary devices for indirect vision and component type-approval number: .....
2. Class of mirrors and devices for indirect vision (VIII)<sup>1</sup>
3. Extension of type approval of the vehicle to cover the following device for indirect vision .....
4. Data for identification of the R point of the driver's seating position: .....
5. Maximum and minimum bodywork width in respect of which the mirror and the devices for indirect vision has been granted type-approval .....
6. The following documents, bearing the type approval number shown above, are annexed to this certificate:.....
  - (a) Drawings showing the mounting of the devices for indirect vision .....
  - (b) Drawings and plans showing the mounting position and characteristics of the part of the structure where the devices for indirect vision are mounted.....
7. Remarks: (e.g. valid for right hand/left hand traffic<sup>1</sup>) .....

---

<sup>1</sup> Strike out what does not apply.

## Annex 5

### Arrangement of approval mark of a device for indirect vision

(See paragraph 5.4. of the Regulation)

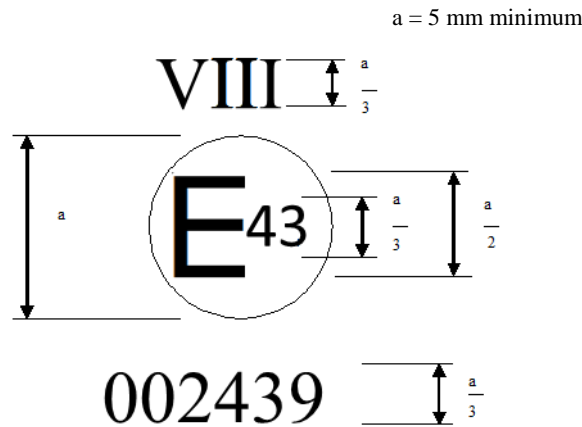

The above approval mark affixed to a device for indirect vision indicates that the device is a main rear-view device, of Class VIII, which has been approved in the Japan (E 43) pursuant to Regulation No. XXX and under approval number 002439. The first two digits of the approval number indicate that the approval was granted in accordance with the requirements of UN Regulation No. XXX in its original form.

*Note:* The approval number and the additional symbol shall be placed close to the circle and either above or below the "E" or to the left or right of that letter. The digits of the approval number shall be on the same side of the "E" and point in the same direction. The additional symbol shall be directly opposite the approval number. The use of Roman numerals as approval numbers shall be avoided so as to prevent any confusion with other symbols.

## Annex 6

### Test method for determining reflectivity

1. Definitions
  - 1.1. CIE standard illuminate A:<sup>1</sup> Colorimetric illuminate, respecting the full radiator at  $T_{68} = 2,855.6$  K.
    - 1.1.2. CIE standard source A<sup>1</sup>: Gas-filled tungsten filament lamp operating at a correlated colour temperature of  $T_{68} = 2,855.6$  K.
    - 1.1.3. CIE 1931 standard colorimetric observer<sup>1</sup>: Receptor of radiation whose colorimetric characteristics correspond to the spectral tristimulus values (see  $\bar{x}(\lambda)$ ,  $\bar{y}(\lambda)$ ,  $\bar{z}(\lambda)$  table).
    - 1.1.4. CIE spectral tristimulus values<sup>1</sup>: Tristimulus values of the spectral components of an equi energy spectrum in the CIE (XYZ) system.
    - 1.1.5. Photopic vision:<sup>1</sup> Vision by the normal eye when it is adapted to levels of luminance of at least several  $\text{cd}/\text{m}^2$ .
  2. Apparatus
    - 2.1. General

The apparatus shall consist of a light source, a holder for the test sample, a receiver unit with a photodetector and an indicating meter (see Figure 1), and means of eliminating the effects of extraneous light.

The receiver may incorporate a light-integrating sphere to facilitate measuring the reflectance of non-flat (convex) mirrors (see Figure 2).
    - 2.2. Spectral characteristics of light source and receiver

The light source shall consist of a CIE standard source A and associated optics to provide a near-collimated light beam. A voltage stabiliser is recommended in order to maintain a fixed lamp voltage during instrument operation.

The receiver shall have a photodetector with a spectral response proportional to the photopic luminosity function of the CIE (1931) standard colorimetric observer (see table). Any other combination of illuminate-filter-receptor giving the overall equivalent of CIE standard illuminate A and photopic vision may be used. When an integrating sphere is used in the receiver, the interior surface of the sphere shall be coated with a matt (diffusive) spectrally non-selective white coating.
    - 2.3. Geometrical conditions

The angle of the incident beam ( $\Theta$ ) should preferably be  $0.44 \pm 0.09$  rad ( $25 \pm 5^\circ$ ) from the perpendicular to the test surface and shall not exceed the

---

<sup>1</sup> Definitions taken from CIE publication 50 (45), International Electrotechnical Vocabulary, Group 45, Lighting

upper limit of the tolerance (i.e. 0.53 rad or 30°). The axis of the receptor shall make an angle ( $\Theta$ ) with this perpendicular equal to that of the incident beam (see Figure 1). The incident beam upon arrival at the test surface shall have a diameter of not less than 13 mm (0.5 inch). The reflected beam shall not be wider than the sensitive area of the photodetector, shall not cover less than 50 per cent of such area, and as nearly as possible shall cover the same area segment as used during instrument calibration.

When an integrating sphere is used in the receiver section, the sphere shall have a minimum diameter of 127 mm (5 inch). The sample and incident beam apertures in the sphere wall shall be of such a size as to admit the entire incident and reflected light beams. The photodetector shall be so located as not to receive direct light from either the incident or the reflected beam.

2.4. Electrical characteristics of the photodetector-indicator unit

The photodetector output as read on the indicating meter shall be a linear function of the light intensity of the photosensitive area. Means (electrical and/or optical) shall be provided to facilitate zeroing and calibration adjustments. Such means shall not affect the linearity or the spectral characteristics of the instrument. The accuracy of the receptor indicator unit shall be within  $\pm 2$  per cent of full scale, or  $\pm 10$  per cent of the magnitude of the reading, whichever is the smaller.

2.5. Sample holder

The mechanism shall be capable of locating the test sample so that the axes of the source arm and receptor intersect at the reflecting surface. The reflecting surface may lie within or at either face of the mirror sample, depending on whether it is a first surface, second surface or prismatic "flip" type mirror.

3. Procedure

3.1. Direct calibration method

In the direct calibration method, air is used as the reference standard. This method is applicable for those instruments, which are so constructed as to permit calibration at the 100 per cent point by swinging the receiver to a position directly on the axis of the light source (see Figure 1).

It may be desired in some cases (such as when measuring low-reflectivity surfaces) to use an intermediate calibration point (between 0 and 100 per cent on the scale) with this method. In these cases, a neutral density filter of known transmittance shall be inserted in the optical path, and the calibration control shall then be adjusted until the meter reads the percentage transmission of the neutral density filter. This filter shall be removed before reflectivity measurements are performed.

3.2. Indirect calibration method

The indirect calibration method is applicable in the case of instruments with fixed source and receiver geometry. A properly calibrated and maintained reflectance standard is required. This reference standard should preferably be a flat mirror with a reflectance value as near as possible to that of the test samples.

3.3. Flat mirror measurement

The reflectance of flat mirror samples can be measured on instruments employing either the direct or the indirect calibration method. The reflectance value is read directly from the indicating meter.

3.4. Non-flat (convex) mirror measurement

Measurement of the reflectance of non-flat (convex) mirrors requires the use of instruments which incorporate an integrating sphere in the receiver unit (see Figure 2). If the instrument-indicating meter indicates  $n_e$  divisions with a standard mirror of  $E$  per cent reflectance, then, with a mirror of unknown reflectance,  $n_x$  divisions will correspond to a reflectance of  $X$  per cent, in accordance with the formula:

$$X = E \frac{n_x}{n_e}$$

Figure 1  
Generalised reflectometer showing experimental set-ups for the two calibration methods

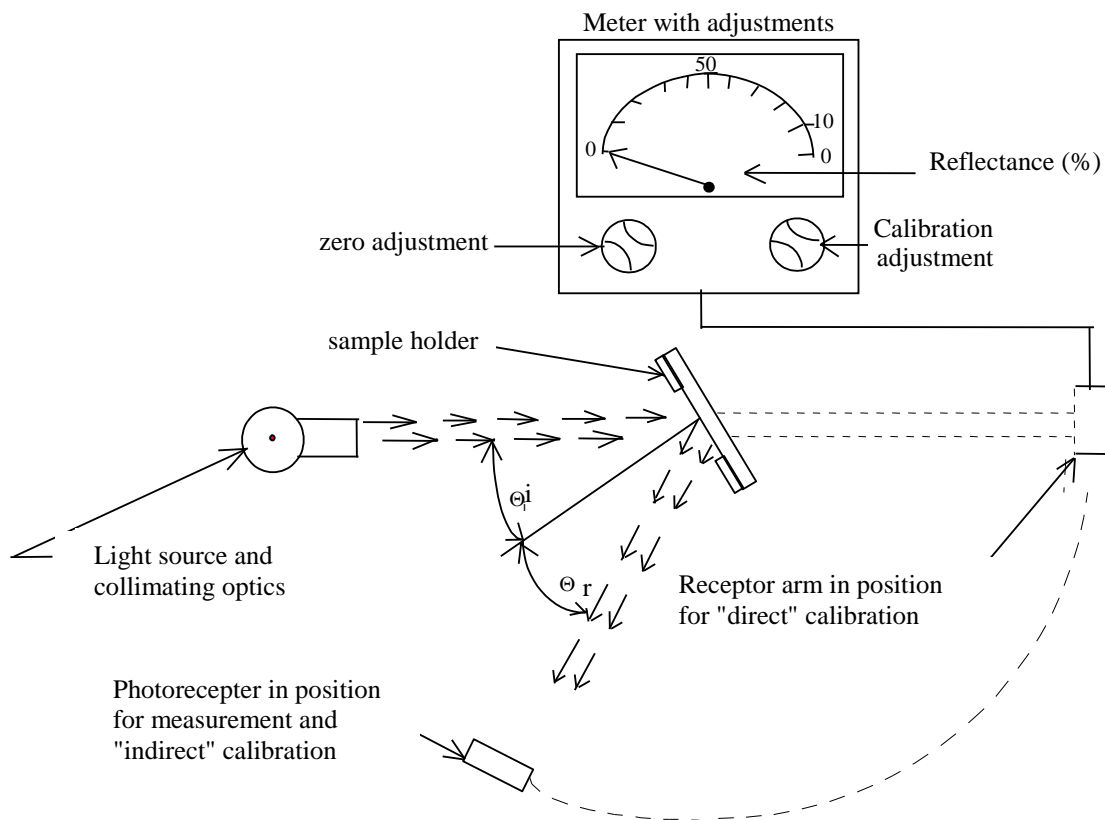
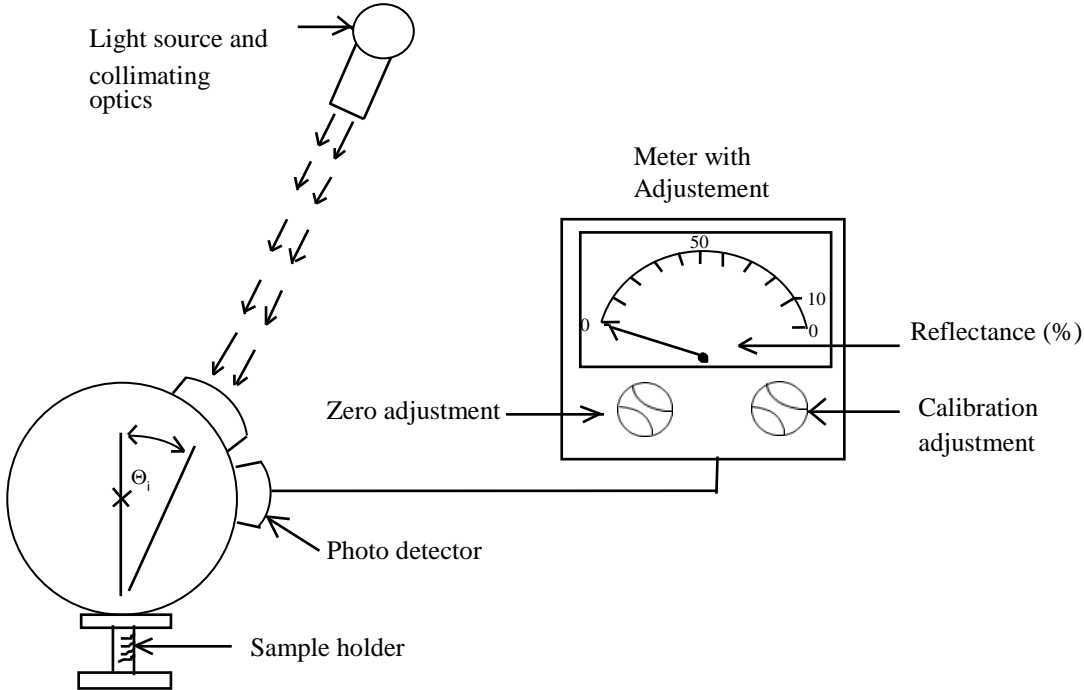



Figure 2  
**Generalised reflectometer, incorporating an integrating sphere in the receiver**



4. Spectral tristimulus values for the CIE 1931 standard colorimetric observer<sup>2</sup>

This table is taken from CIE publication 50 (45) (1970)

$\lambda$ nm	$\bar{x}(\lambda)$	$\bar{y}(\lambda)$	$\bar{z}(\lambda)$
380	0.001 4	0.000 0	0.006 5
390	0.004 2	0.000 1	0.020 1
400	0.014 3	0.000 4	0.067 9
410	0.043 5	0.001 2	0.207 4
420	0.134 4	0.004 0	0.645 6
430	0.283 9	0.011 6	1.385 6
440	0.348 3	0.023 0	1.747 1
450	0.336 2	0.038 0	1.772 1
460	0.290 8	0.060 0	1.669 2
470	0.195 4	0.091 0	1.287 6
480	0.095 6	0.139 0	0.813 0
490	0.032 0	0.208 0	0.465 2
500	0.004 9	0.323 0	0.272 0
510	0.009 3	0.503 0	0.158 2
520	0.063 3	0.710 0	0.078 2
530	0.165 5	0.862 0	0.042 2
540	0.290 4	0.954 0	0.020 3
550	0.433 4	0.995 0	0.008 7
560	0.594 5	0.995 0	0.003 9
570	0.762 1	0.952 0	0.002 1
580	0.916 3	0.870 0	0.001 7
590	1.026 3	0.757 0	0.001 1
600	1.062 2	0.631 0	0.000 8
610	1.002 6	0.503 0	0.000 3
620	0.854,4	0.381 0	0.000 2
630	0.642 4	0.265 0	0.000 0
640	0.447 9	0.175 0	0.000 0
650	0.283 5	0,107 0	0.000 0
660	0.164 9	0.061 0	0.000 0
670	0.087 4	0,032 0	0.000 0
680	0.046 8	0.017 0	0.000 0
690	0.22 7	0,008 2	0.000 0
700	0.011 4	0.004 1	0.000 0
710	0.005 8	0.002 1	0.000 0
720	0.02 9	0.001 0	0.000 0
730	0.001 4	0.000 5	0.000 0
740	0.000 7	0.000 2 (*)	0.000 0
750	0.000 3	0.000 1	0.000 0
760	0.000 2	0.000 1	0.000 0
770	0.000 1	0.000 0	0.000 0
780	0.000 0	0.000 0	0.000 0

(\*) Changed in 1966 (from 3 to 2)

<sup>2</sup> Abridged table. The values of  $y(\lambda) = V(\lambda)$  are rounded off to four decimal places

Explanatory figure

**Example of device for measuring the reflection factor of spherical mirrors**

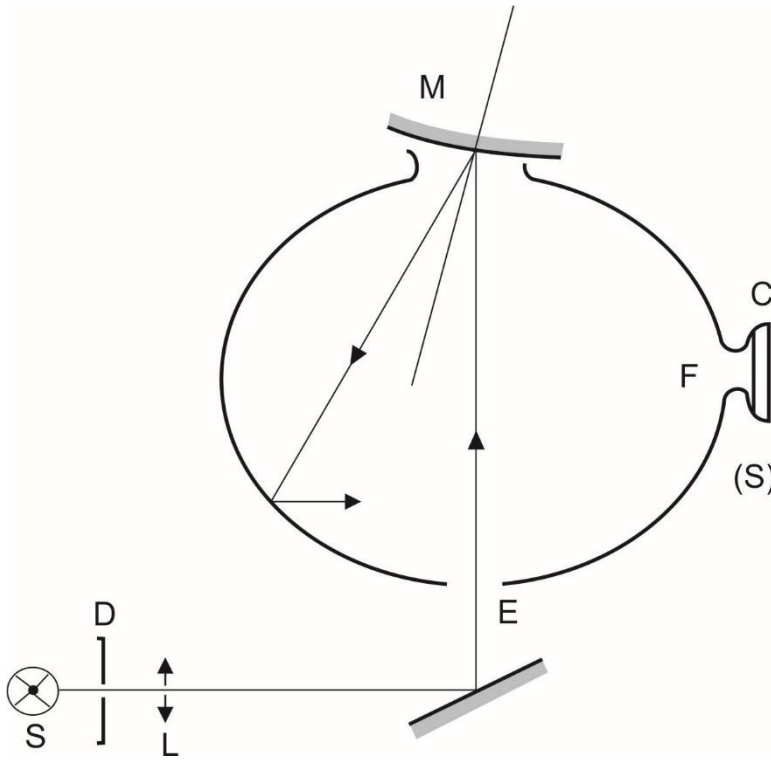

- C = Receiver
- D = Diaphragm
- E = Window of entry
- F = Window of measurement
- L = Lens
- M = Object window
- S = Light source
- (S) = Integrating sphere

## Annex 7

### Procedure for determining the radius of curvature "r" of the reflecting surface of a mirror

1. Measurement
  - 1.1. Equipment

A "spherometer" similar to the one described in Figure 1 of this annex having the indicated distances between the tracing pin of the dial gauge and the fixed legs of the bar is used.
  - 1.2. Measuring points
    - 1.2.1. The principal radii of curvature shall be measured at three points situated as close as possible to positions at one-third, one-half and two-thirds of the distance along the arc of the reflecting surface passing through the centre of this surface and parallel to segment b, or of the arc passing through the centre of the reflecting surface which is perpendicular to it if this arc is the longer.
    - 1.2.2. Where, owing to the size of the reflecting surface, it is impossible to obtain measurements in the directions defined in paragraph 2.1.1.5. of this Regulation, the Technical Services responsible for the tests may take measurements at the said point in two perpendicular directions as close as possible to those prescribed above.
2. Calculation of the radius of curvature "r"

"r" expressed in mm is calculated from the formula:

$$r = \frac{r_p1 + r_p2 + r_p3}{3}$$

Where:

- $r_p1$  = the radius of curvature at the first measuring point,  
 $r_p2$  = the radius of curvature at the second measuring point,  
 $r_p3$  = the radius of curvature at the third measuring point.

Figure 1  
**Spherometer**

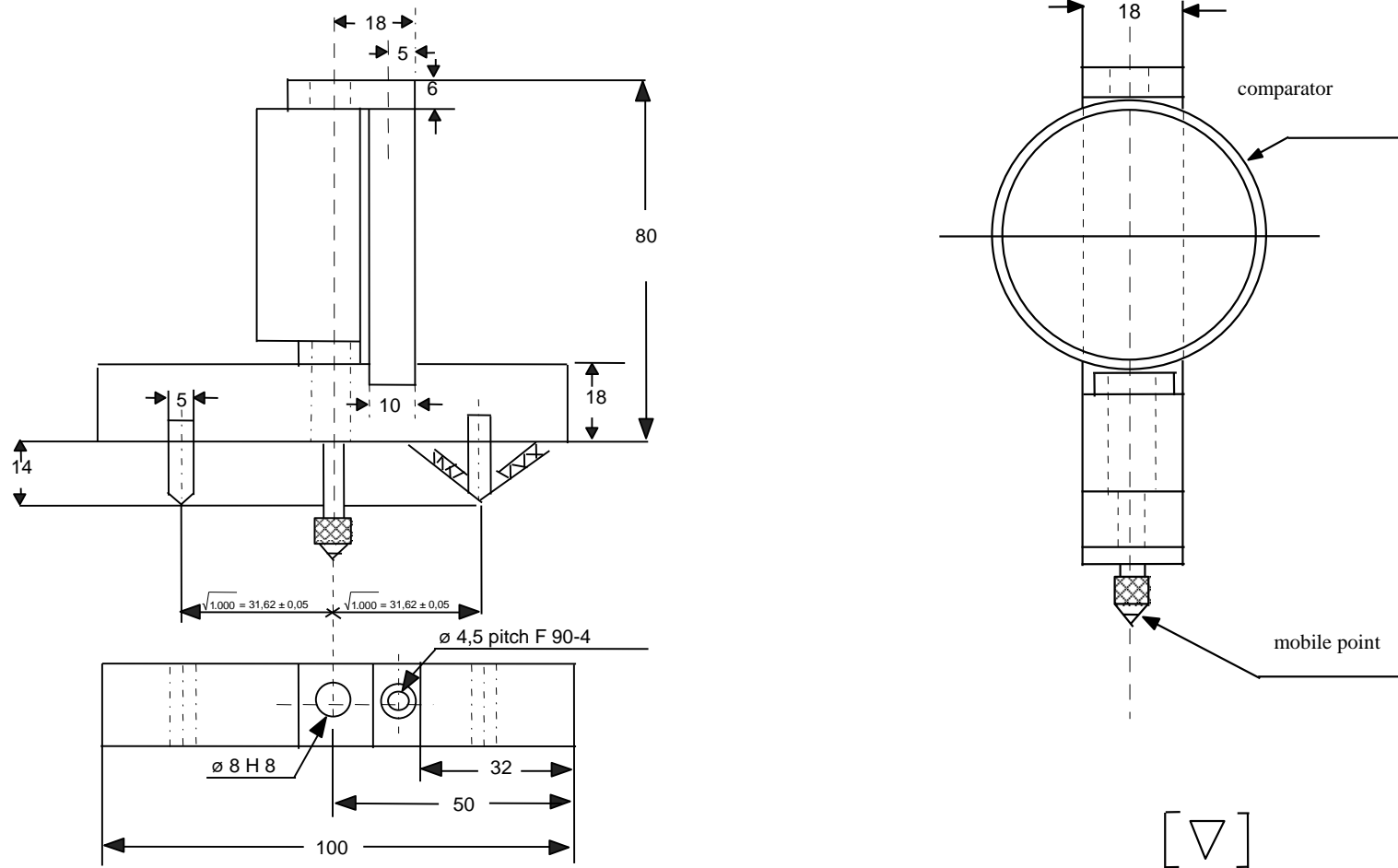

## **Annex 8**

### **Procedure for determining the "H" point and the actual torso angle for seating positions in motor vehicles<sup>1</sup>**

#### **Appendix 1 - Description of the three dimensional "H" point machine (3-D H machine)<sup>1</sup>**

#### **Appendix 2 - Three-dimensional reference system<sup>1</sup>**

#### **Appendix 3 - Reference data concerning seating positions<sup>1</sup>**

---

<sup>1</sup> The procedure is described in Annex 1 to the Consolidated Resolution on the Construction of Vehicles (R.E.3) (document ECE/TRANS/WP.29/78/Rev.4).  
[www.unece.org/trans/main/wp29/wp29wgs/wp29gen/wp29resolutions.html](http://www.unece.org/trans/main/wp29/wp29wgs/wp29gen/wp29resolutions.html)

---

## Annex 9

### Need to check compatibility for test object specification.

## Calculation of the detection distance for CMS of Class VIII

### 1. Camera monitor device for indirect vision

#### 1.1. Determination of the smallest discernable detail

The smallest discernable detail of the naked eye shall be defined according to standard ophthalmologic tests like the Landolt C test or the Triangle Orientation Discrimination (TOD) test. The smallest discernable detail at the centre of the viewing system can be determined using the Landolt C test or the TOD test. In the rest of the viewing area the smallest discernable detail may be estimated from the centrally determined smallest discernable detail and the local image deformation. For instance, in the case of a digital camera the smallest discernable detail at a given pixel location (in the monitor) scales inversely with the solid angle of the pixel.

##### 1.1.1. Landolt-C test

In the Landolt-C test, test symbols are judged by the subject under test. In accordance with this test the smallest discernable detail is defined as the visual angle of the gap size of the Landolt C symbol at threshold size and is expressed in arcmin. The threshold size corresponds to the size at which the subject judges the orientation correctly in 75 per cent of the trials. The smallest discernable detail is determined in a test involving a human observer. A test chart containing test symbols is placed in front of the camera and the observer judges the orientation of test symbols from the monitor. From the threshold gap size of the Landolt C test symbol  $d$  [m] and the distance between the test pattern and the camera  $D$  [m] the smallest discernable detail  $\omega_c$  [arcmin] is calculated as follows:

$$\omega_c = \frac{d}{D} \cdot \frac{180 \cdot 60}{\pi}$$

##### 1.1.2. TOD test

The Landolt C test can be used to determine the smallest discernable detail of the camera-monitor system. However, for sensor systems it is more suitable to use the TOD (Triangle Orientation Discrimination) method which is similar to the Landolt C method, but involves equilateral triangular test patterns. The Triangle Orientation Discrimination method is described in detail by Bijl & Valeton (1999), who provide practical guidelines on how to perform a TOD measurement. In the method, triangular test patterns (see Figure 1) are viewed through the viewing system under test. Each triangle can have one out of four possible orientations (apex up, left, right or down) and the observer indicates/guesses for each triangle its orientation. When this procedure is repeated for many (randomly oriented) triangles of different sizes the fraction of correct responses can be plotted (see Figure 2), and increases with test pattern size. The threshold is defined as the point at which the fraction correct crosses the 0.75 level and can be obtained by fitting a smooth function through the data (see Bijl & Valeton, 1999). Critical perception is reached when the critical object diameter equals two times the

width of the triangle at threshold size. The smallest discernable detail ( $\omega_c$ ) is equal to 0.25 times the width of the triangle at threshold size. This means that, from the threshold triangle width  $w$  [m] and the distance between test pattern and the camera  $D$  [m] the smallest discernable detail  $\omega_c$  [arcmin] is calculated as follows:

$$\omega_c = \frac{w}{4 \cdot D} \cdot \frac{180 \cdot 60}{\pi}$$

Figure 1  
**Triangular test patterns used in the Triangle Orientation Discrimination (TOD) method**

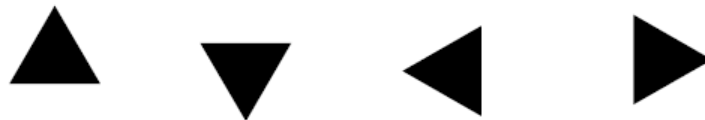
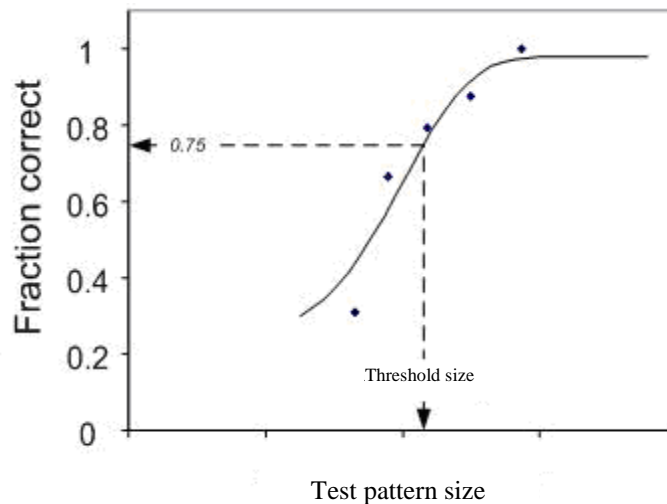

Figure 2  
**Typical relationship between the size of the triangle and the fraction of correct responses**



1.2. Determination of the critical viewing distance of the monitor

For a monitor having certain dimensions and properties, the distance to the monitor can be calculated within which the detection distance is dependent only on the performances of the camera. The critical viewing distance  $r_{\text{mcr}}_{\text{crit}}$  is defined as the distance at which the smallest discernable detail displayed on the monitor spans 1 arcmin measured from the eye (the acuity threshold of a standard observer).

$$r_{\text{mcr}}_{\text{crit}} = \frac{\delta \cdot 60 \cdot 180}{\pi}$$

Where:

$r_{\text{mcr}}_{\text{crit}}$  : critical viewing distance of the monitor [m]



$\delta$  : size of the smallest discernable detail on the monitor [m]

1.3. Determination of the detection distance

1.3.1. Maximum detection distance within the critical viewing distance where, due to the installation, the distance eye-monitor is less than the critical viewing distance, the maximum attainable detection distance is defined as:

$$r_{\text{dclose}} = \frac{D_0 \cdot 60 \cdot 180}{\omega_c \cdot \pi \cdot f}$$

Where:

$r_{\text{dclose}}$ : detection distance [m]

$D_0$ : diameter of the critical object [m] according to paragraph 2.1.2.6. of this Regulation; for the calculation of  $r_{\text{dclose}}$  for Class V and VI devices, a representative value of 0.30 m shall be used

$f$ : threshold increasing factor, which is equal to 8

$\omega_c$ : smallest discernable detail [arcmin]

1.3.2. Detection distance greater than the critical viewing distance. Where, due to the installation, the distance eye-monitor is more than the critical viewing distance, the maximum obtainable detection distance is defined as:

$$r_{\text{dfar}} = \frac{r_{\text{mcrit}}}{r_m} r_{\text{dclose}} \quad [\text{m}]$$

Where:

$r_{\text{dfar}}$ : detection distance for distances larger than the critical viewing distance [m]

$r_{\text{dclose}}$ : detection distance for distances smaller than the critical viewing distance [m]

$r_m$ : viewing distance, i.e. distance between eye and monitor [m]

$r_{\text{mcrit}}$ : critical viewing distance [m]

2. Secondary functional requirements

Based on the installation conditions, a determination shall be made to discover whether the entire device can still satisfy the functional requirements listed in paragraph 6.2.2. of this Regulation, specifically the glare correction, the maximum and the minimum luminance of the monitor. It shall also be determined the degree to which the glare correction will be addressed and the angle at which sunlight can strike a monitor and these shall be compared to the corresponding measuring results from the system measurements. This can be either based on a CAD-generated model, a determination of the angles of light for the device when mounted on the relevant vehicle, or by carrying out relevant measurements on the relevant vehicle as described in paragraph 6.2.2.2. of this Regulation.

---

## Annex 11

### Need to check compatibility for new test object specification.

#### Determination of the displayed object size for CMS of Class VIII

1. Camera monitor device for indirect vision
  - 1.1. General

Determination of the displayed object size considers the possible appearance of smear. The impact on the monitors image and consequence is the occultation of the field of view and therefore of the object. The following differentiation is made:
  - 1.2. Case A: Smear appears
    - 1.2.1. Step 1: Under the condition described in paragraph 6.2.2.2.1.2. of this Regulation, measure the width (s) of the vertical bar displayed on the monitor e.g. with a measurement microscope.
    - 1.2.2. Step 2: Place the object at a defined distance from the camera. Measure the width of the object displayed on the monitor (b) in a situation without real sun light condition e.g. with a measurement microscope.
    - 1.2.3. Step 3: Calculate the residual object width ( $\alpha$ ) according to the following equation:

$$\alpha ['] = 60 \times 2 \times \arctan \frac{b-s}{2 \times r}$$

Where:

- $\alpha$ : residual width of the object displayed on the monitor (with smear) [minutes of arc]
- b: width of the object displayed on the monitor (without smear) [mm]
- s: width of the smear [mm]
- r: viewing distance [mm]

- 1.3. Case B: Smear does not appear
  - 1.3.1. Step 1: Place the object at a defined distance from the camera. Measure the width of the object displayed on the monitor (b) in a situation without real sun light condition e.g. with a measurement microscope.
  - 1.3.2. Step 2: Calculate the object width ( $\alpha$ ) according to the following equation:

$$\alpha ['] = 60 \times 2 \times \arctan \frac{b}{2 \times r}$$

Where:

- $\alpha$ : width of the object displayed on the monitor (without smear) [minutes of arc]
- b: width of the object displayed on the monitor (without smear) [mm]

- 1.4. r: viewing distance [mm]  
Data supplied by the instructions for use

In the case of Classes VIII camera monitor devices the instructions for use shall include a table that shows the minimum and maximum mounting height of the camera above ground under consideration of different viewing distances. The camera shall be mounted within the applicable height range. The viewing distances shall be selected from the intended context of use. The following table shows an example.

Viewing distance	0.5 m	1.0 m	1.5 m	2.0 m	2.5 m
Minimum mounting height	para. 1.4.1.	para. 1.4.1.	para. 1.4.1.	para. 1.4.1.	para. 1.4.1.
Maximum mounting height	para. 1.4.2.	para. 1.4.2.	para. 1.4.2.	para. 1.4.2.	para. 1.4.2.

- 1.4.1. The value of the minimum mounting height is the same for all viewing distances as it is independent of the viewing distance. It is determined by the dimensions of the field of vision and the field of view of the camera. Use the following working steps for determination of the minimum mounting height.

1.4.1.1. Step 1: Draw the intended field of vision on ground.

1.4.1.2. Step 2: Place the camera above the field of vision in such a way that the camera is viewing the field of vision. The lateral position shall be in accordance with the intended mounting position at the vehicle.

1.4.1.3. Step 3: Change the height of the camera above ground in such a way, that the field of vision displayed on the monitor covers an area at least as large as the field of vision. Furthermore, the field of vision display shall encompass the entire monitor screen.

1.4.1.4. Step 4: Measure the height between camera and ground which is the minimum mounting height. Report the result value.

1.4.2. The value of the maximum mounting height is different for different viewing distances as the displayed object size varies with the mounting height. Use the following working steps for determination of the maximum mounting height:

1.4.2.1. Step 1: Determine the minimum width  $b_{\min}$  of the critical object displayed on the monitor for each viewing distance.

$$b_{\min} = 2 \times r \times \tan \frac{8'}{2 \times 60}$$

Where:

r: viewing distance [mm]

$b_{\min}$ : minimum width of the critical object displayed on the monitor [mm]

- 1.4.2.2. Step 2: Place the critical object inside the drawn intended field of vision in a position at which the distance between the critical object and the camera is largest. The illumination conditions shall be in such a way that the critical object is clearly visible on the monitor.
- 1.4.2.3. Step 3: Select the first value of the possible viewing distances.
- 1.4.2.4. Step 4: Change the height of the camera above ground in such a way, that the residual width  $B$  of the object displayed on the monitor is equal to the minimum width allocated to that viewing distance.

$$B=b_{\min}$$

Where:

- $B$ : residual width of the object displayed on the monitor (which is "b" in cases without smear and "b – s" in cases with smear) in mm (see paragraph 1.1. General)
- 1.4.2.5. Step 5: Measure the height between camera and ground which is the maximum mounting height allocated to that viewing distance. Report the result value.
- 1.4.2.6. Step 6: Repeat the aforementioned steps 4 and 5 for the other viewing distances.

---

## Annex 12

### Test conditions for Class VIII field of vision.

1. Field of vision

The requirements of field of vision defined in paragraph 15.2.3. of this regulation can be tested in the conditions described in this Annex.

1.1. Test objects

Each test object is a right circular cylinder that is 1.0 m high and 0.3 m in external diameter. Each test are marked as follows.

(a) Test objects has 0.15 m x 0.15 m painted patch that can be moved from the bottom to the uppermost of the side of the cylinder.

(b) Both the painted patch shall be of a color that contrasts with both the rest of the cylinder and the test surface.

#### [OICA PROPOSAL]

1.1. Test objects

Each test object is a right circular cylinder that is **0.8 ± 0** m high and 0.3 m in external diameter. Each test are marked as follows.

Figure A

#### Test object

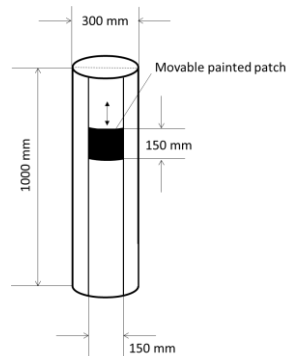

1.2. Test object locations and orientation.

Place the test objects at locations specified in (a) to (h) and illustrated in Figure B. Measure the distances shown in Figure B from a test object to another test object or other object from the cylindrical center (axis) of the test object as viewed from above. Each test object is oriented so that its axis is vertical.

(a) Place test objects A, B and C so that their centers are in a transverse vertical plane that is 0.3 m to the rear of a transverse vertical plane tangent to the rearmost surface of the rear bumper.

(b) Place test object B so that its center is in a longitudinal vertical plane passing through the vehicle's longitudinal centerline.

(c) Place test objects D, E and F so that their centers are in a transverse vertical plane that is 1.5 m to the rear of a transverse vertical plane tangent to the rearmost surface of the rear bumper.

(d) Place test object E so that its center is in a longitudinal vertical plane passing through the vehicle's longitudinal centerline.

(e) Place test objects G, H and I so that their centers are in a transverse vertical plane that is 3.5 m to the rear of a transverse vertical plane tangent to the rearmost surface of the rear bumper.

(f) Place test object H so that its center is in a longitudinal vertical plane passing through the vehicle's longitudinal centerline.

(g) Place test objects A, D, and G so that their outermosts are in a longitudinal vertical plane tangent to the left-side outermost surface of the vehicle.

(h) Place test objects C, F, and I so that their outermosts are in a longitudinal vertical plane tangent to the right-side outermost surface of the vehicle.

Test object locations can be added between A to I by Technical Service.

Figure B

Test object location

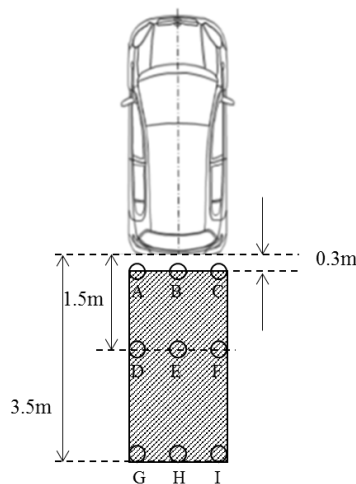

1.3. Requirements.

(a) for the test objects in the first row (Test object A, B, and C);

0.15 m x 0.15 m area or top of the test object should be seen to at least at one position on each test object. 0.15 m x 0.15 m area can be replaced to at least 3 bands 0.05 m apart continuously on each test object.

(b) for the test objects in the second row (Test object D, E, and F) and the third row (Test object G, H, and I);

Whole height of the test object should be seen.

---

## Annex 13

Updated (Requirements moved to chapter 17, test method updated, renumbered)

### Test Methods for Detection Systems

1. Detection latency test method
11. Test conditions

The testing environment and test object shall be as per paragraph 3. of this annex. One test object is used. The distance from the rear edge to the test object and the position of the test object are selected by the manufacturer to ensure the detection of the test object. The test object shall be located in the detectable grids within the rear horizontal area in paragraph 5. of this annex. The test vehicle in the initial state shall be with the detection system being activated, which is declared [by the manufacturer OR in owner's manual] and shall be in a parking condition. Here, parking condition means the P (park) position being selected in the case of vehicles equipped with automatic transmissions, whereas it means the neutral gear being selected and the parking brake being engaged in the case of vehicles equipped with manual transmissions.
- 1.2. Test procedures
  - (a) With the vehicle being in the initial state, locate the test object behind the vehicle and select the reverse gear.
  - (b) Measure the elapsed time (detection latency) from the moment at which the reverse gear is selected as specified by the manufacturer of the vehicle to the moment at which the audible warning starts.
2. Rear horizontal area detection test methods

Audible warning systems shall fulfil the test as specified in paragraphs 2.1. in this Annex. However, if audible warning systems fulfills the test as specified in paragraphs 2.2. in this Annex, the test as specified in paragraph 2.1. in this Annex shall be considered to be satisfied.
- 2.1. Test method for detection
  - 2.1.1. Monitoring area

The maximum detection distance in paragraphs 5.4.2. and 5.4.3. of ISO 17386:2010 shall be [1.0] m (Class R2). The width of the rectangle,  $w_r$ , is equal to the vehicle width, measured along the rear axle. The dimensions shall be rounded up to the nearest 0,1 m. The figure below gives examples of different  $w_r$ . (Figure 1 and 2)

Figure 1

In the case of odd-numbered poles in the vehicle lateral direction (e.g.  $w_r=1,67m$ )

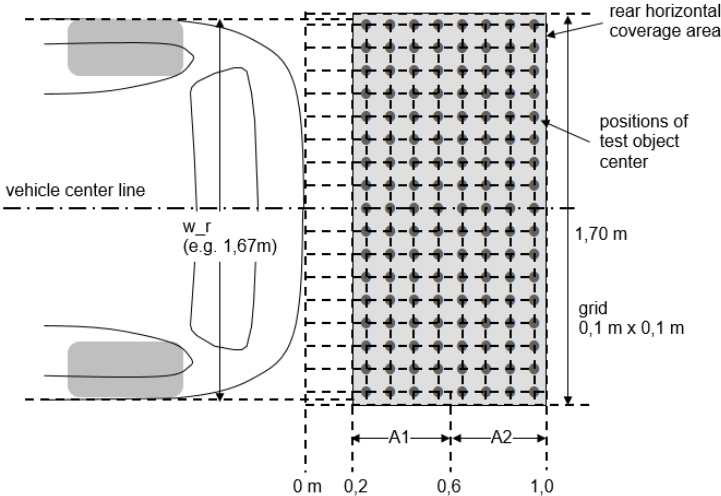
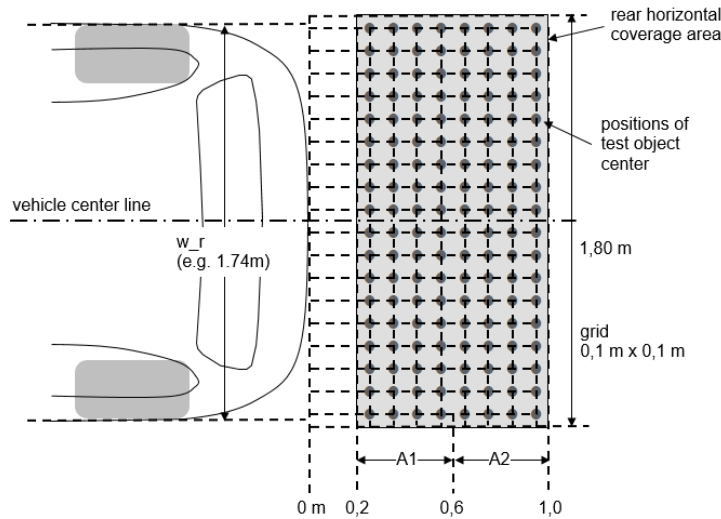



Figure 2

In the case of even-numbered poles in the vehicle lateral direction (e.g.  $w_r=1,74\text{m}$ )



### 2.1.2. Minimum detection rate

The minimum detection rate required for the rear horizontal area shall be as follows:

- (a) 90 percent for A1 as defined in paragraph 5.4.3. of ISO 17386:2010;
- (b) 87 percent for the rear-2 range in A2 as defined in paragraph 5.4.3. of ISO 17386:2010.

There shall be no undetected hole larger than a square consisting of two-by-two grids.

Here, the rear horizontal area test procedures shall be as per paragraph 7.3. of ISO 17386:2010.

When the warning provided more than [five] seconds continuously, it is judged as test object is detected. The detection test shall be performed [one] time for each test object. However, if necessary, according to the agreement of Technical Service and manufacturer, it can be judged as the test object is detected in case that warnings are provided in [four] tests out of [five] tests.

### 2.2. Simplified test method

#### 2.2.1. Monitoring area

Monitoring areas are six points as shown in below figure 3 or 4 within the monitoring area of paragraph 2.1.1.

Figure 3

In the case of odd-numbered poles in the vehicle lateral direction (e.g.  $w_r=1,67\text{m}$ )

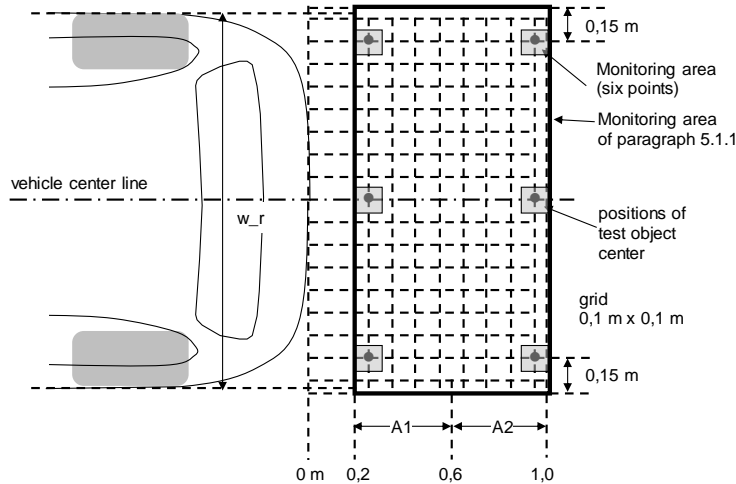
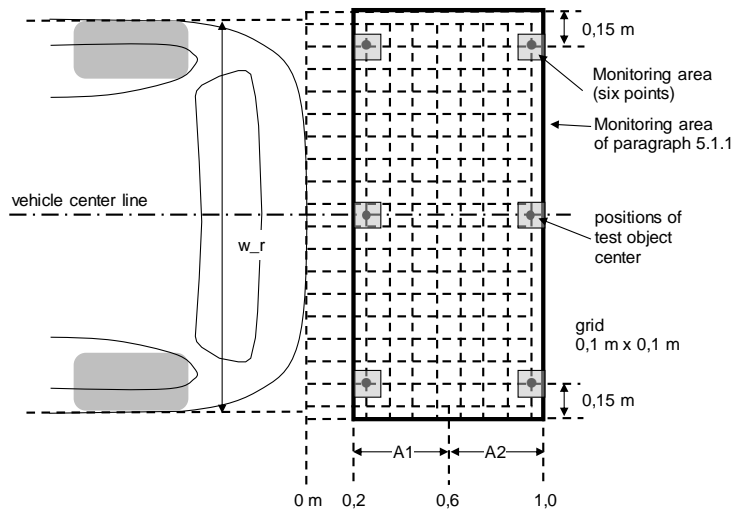

Figure 4

In the case of even-numbered poles in the vehicle lateral direction (e.g.  $w_r=1,74\text{m}$ )



### 2.2.2. Minimum detection rate

The minimum detection rate required for the area of six points shall be 100%.

When the warning provided more than [five] seconds continuously, it is judged as test object is detected. The detection test shall be performed [one] time for each test object. However, if necessary, according to the agreement

of Technical Service and manufacturer, it can be judged as the test object is detected in case that warnings are provided in [four] tests out of [five] tests.

3. Self-test capabilities and failure indication

As per paragraph 5.5. of ISO 17386:2010. The system shall provide the self-test functions. It shall generate a warning signal, which is audible or visible or both, whenever a fault condition is detected.

## **II. Justification**

This proposal is an update and rebuild of GRSG-116-10 on the Class VIII field of vision based on the discussions and conclusions of VRU-Proxi Informal Working Group. Key update are rebuild as new regulation proposal and modifications of requirements. This proposal is also under reflection of ongoing discussions in the VRU-Proxi Informal Working Group.

---