

Task Force 3 – Testing Procedures Meeting Notes – Stuttgart – Nov. 4, 2019

- Worked through TPRD comments to harmonize with industry standards ANSI/CSA HPRD 1 and ISO 19882 – we need to ensure the language is appropriate for CP enforcement.
- Reviewed TMC proposals for manifolded conformable container and discussion ranged from GTR not ready to accept new concepts (lack of experience, data) to GTR should not stifle innovation.

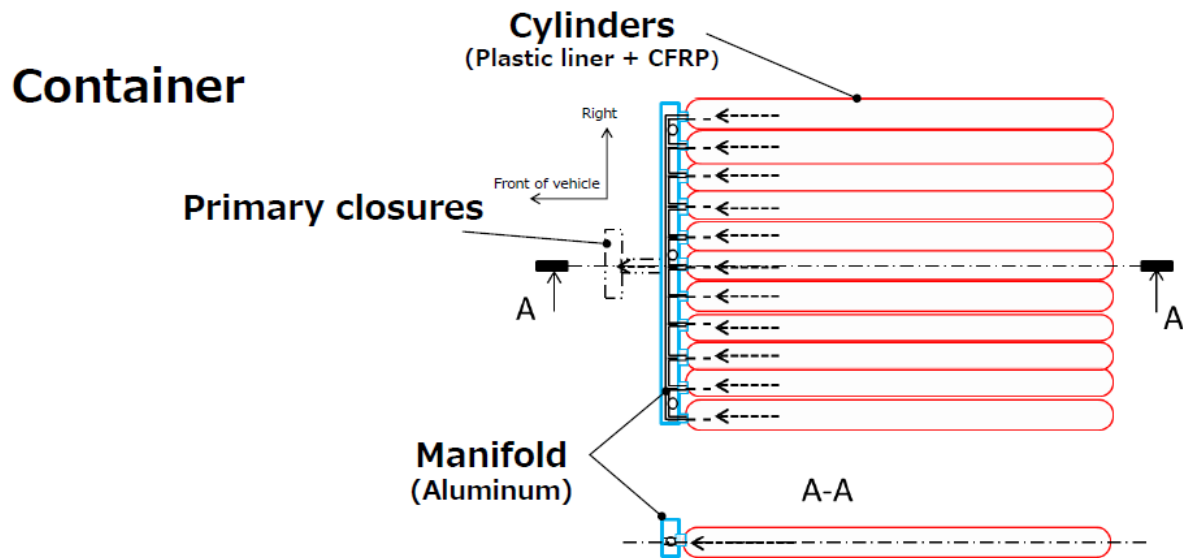

Fig : Container

- Some of the issues with the TMC proposal (and by extension, proposals submitted by Linamar but not discussed), included:
  - Manifolding creates an issue with one container/one OTV requirement, so a new definition for container was proposed
  - Elimination of 25mm flaw because straps not employed opens the door for neck mount containers to be exempt – also misunderstanding of the reason for the 25mm flaw
  - Vibration not considered
- TF 3 asked TMC and Linamar to present detailed proposals for changes to test procedures to accommodate conformable containers (considering all possible vulnerabilities)
- Paul Karzel reported that after several workshops on the issue of high in-tank gas temperature condition created by loss of pressure ramp rate control by the filling station, there is no resolution yet, but follow up actions are being explored.
- One recommendation might be to include a high flow cycle during the pneumatic sequential test.
- The J-OEMs believe that this issue is not a concern.
- Reviewed comments submitted by Hexagon, JAMA, NHTSA and TMC with majority of issues resolved with the exception of a new table describing the revised pneumatic sequential test (provided by Powertech) and NHTSA proposal for drop test modification.

**Ambient and extreme temperature gas pressure cycling test parameters**

No. of cycles	Ambient Conditions	Initial System Equilibration	Fuel Delivery Temperature	Initial Pressure	Target Pressure
5	≤ -25°C	≤ -25°C	20°C ± 5°C	≤ 2 MPa	≥ 100 per cent NWP*
5	≤ -25°C	≤ -25°C	-33°C to -40°C	≤ 2 MPa	95-100% SOC
15	≤ -25°C	N/A	-33°C to -40°C	≤ 2 MPa	95-100% SOC
5	≥ +50°C, ≥ 80 per cent relative humidity	≥ +50°C, ≥ 80 per cent relative humidity	-33°C to -40°C	≤ 2 MPa	95-100% SOC
20	≥ +50°C, ≥ 80 per cent relative humidity	N/A	-33°C to -40°C	≤ 2 MPa	95-100% SOC
200	+20°C ± 15°C	N/A	-33°C to -40°C	≤ 2 MPa	95-100% SOC
1 <sup>st</sup> permeation	≥ +55°C	≥ +55°C	N/A	N/A	≥ 115 per cent NWP*
25	≥ +50°C, ≥ 80 per cent relative humidity	N/A	-33°C to -40°C	≤ 2 MPa	95-100% SOC
25	≤ -25°C	N/A	-33°C to -40°C	≤ 2 MPa	95-100% SOC
200	+20°C ± 15°C	N/A	-33°C to -40°C	≤ 2 MPa	95-100% SOC
2 <sup>nd</sup> permeation	≥ +55°C	≥ +55°C	N/A	N/A	≥ 115 per cent NWP*

- NHTSA proposes that only one drop test be required, instead of four drops on one container, or four drops on four containers. NHTSA argues that four drops are not realistic and that CPs should pick one orientation only, but container manufacturers must ensure they meet all four drop orientations. Container manufacturers counter-argue that this approach will place more testing burden on them. This issue remained unresolved and was tabled for the next meeting.
- Remaining items to be resolved include content for conformable containers, agreement on the revised pneumatic sequential test, changes or additions related to loss of pressure ramp rate control, changes to the drop test, and any changes related to TF 4 fire testing requirements. We also need to begin process of creating the rationale for major changes.
- TF 3 would like to request a full day meeting at the next IWG session in Japan.