

**Economic and Social Council**

Distr.: General
19 July 2019

Original: English

Economic Commission for Europe

Inland Transport Committee

World Forum for Harmonization of Vehicle Regulations

Working Party on General Safety Provisions

117th session

Geneva, 8-11 October 2019

Item 7 of the provisional agenda

Awareness of the proximity of Vulnerable Road Users

**Proposal for a new UN Regulation on the approval of devices
for reversing motion and motor vehicles with regard to the
driver's awareness of vulnerable road users behind vehicles**

**Submitted by the Informal Working Group on Awareness of
Vulnerable Road Users Proximity***

The text reproduced below was prepared by the experts of the Informal Working Group (IWG) on Awareness of Vulnerable Road Users Proximity (VRU-Proxi) to improve the rear field of vision and the driver's awareness of vulnerable road users behind vehicles.

OICA Comment: Green

Japan Comment: Purple

Corrected part by Japan: Red

* In accordance with the programme of work of the Inland Transport Committee for 2018–2019 (ECE/TRANS/274, para. 123 and ECE/TRANS/2018/21/Add.1, Cluster 3.1), the World Forum will develop, harmonize and update UN regulations in order to enhance the performance of vehicles. The present document is submitted in conformity with that mandate.

I. Proposal

UN Regulation No. [XXX]¹

Proposal for a new UN Regulation on uniform provisions concerning the approval of devices for reversing motion and motor vehicles with regard to the driver's awareness of vulnerable road users behind vehicles

Introduction (for information)

The purpose of this Regulation is to provide the provisions for reversing motion concerning on awareness of vulnerable road users proximity. UN Regulation No. 46. provides the provisions for indirect vision of motor vehicles. This Regulation expands driver's vision or awareness for vehicle rear direction when in reversing motion. Therefore, some requirements of this Regulation may be satisfied by devices complying with UN Regulation No.46.

1. Scope

This Regulation applies to:

- 1.1. Approval of devices for reversing safety defined in Part I intended to be fitted to vehicles of category M and N.

OICA Comment: What is the need for having a component approval (after-market)? The intention of this regulation is a vehicle performance. In addition to that remark, there is no component approval for detection system. Which entity needs to be approved?

Japan Comment: Component approval is for utilization of parts between vehicles.

- 1.2. Approval of vehicle installation of devices for reversing safety defined in Part II if fitted to vehicles of category M and N.
- 1.3. At the request of the manufacturer, Contracting Parties may grant approvals under Parts I and II to vehicles of other categories and devices for fitting to such vehicles.

OICA Comment: Part I may be deleted or some requirements from part I may be transferred to part II

Japan Comment: Component approval is for utilization of parts between vehicles. So, we think part I should be kept as it is.

- 1.4. The following vehicles of category M and N **shall be exempted from this Regulation:** ~~do not need to comply with this Regulation,~~

- Vehicles that cannot comply with reversing motion requirements because they are not compatible with its purpose (with the agreement of the Technical Service)

~~—[Vehicles fitted with an active system.]~~

- Vehicles intended to be used with a semi-trailer shall be exempted from this Regulation.

OICA Justification: already discussed in the previous IWG meeting with CP

¹ The Regulation number will be known of the time of entry into force of this UN Regulation. [XXX] is intended to be replaced by the Regulation number once known.



Utilization of tractor-units as solo vehicles

DRAFT PROPOSAL
SEPTEMBER 2019

Analysis set-up:

- Investigation has been done on a fleet of vehicles (DAF Connect):
 - Sample size: approximately 10.000 tractor units
 - Evaluated driving time of each vehicle: 400h – 2 years

- The discrimination between tractor unit as solo and as combination was based on the total vehicle weight (GCW of 10t) estimated on-board by the mass estimator in the electronic braking system and/or automated transmission.



Results of analysis (tractor-units driving solo)

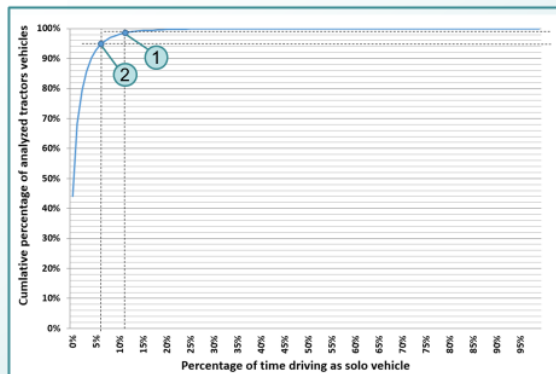

Results based on this sample:

- 99% of tractor units are driving 11% or less of the driving time as solo vehicle ①
- 95% of tractor units are driving 6% or less of the driving time as solo vehicle ②
- 75% of tractor units are driving almost never (less than 0.2%) as solo vehicle

Conclusions:

- Very low occurrence of tractor-units driving solo
- OICA proposal to exempt tractor units from the reversing motion legislation

- 1.5. If a vehicle has multiple devices, the manufacturer may designate the device that meets the provisions of the regulation. ~~The manufacturer must provide a general description of other devices.~~

OICA Justification: We propose to delete the last sentence. “General description of other devices” is not clear, e.g. a camera/comfort system may be optional in addition to the mandatory detection system (at the choice of manufacturer). OICA not in favour of considering optional systems in a type approval.

Japan Comment: This part is based on discussion results in last VRU-IWG.

Part I - Devices for Reversing Motion

2. Definitions

Comment: Do we all have the same understanding of the definitions?

- Devices for reversing motion:
 - o Include Indirect vision + direct vision + Other (grey ring)
 - If yes, we shall modify the definition
 - If no, what is a device for reversing motion?
 - o Include Indirect vision only?
 - If yes, it is equivalent to the definition “close proximity rear view device”

Japan Comment: It is Indirect Vision only.

- We propose to replace Camera-Monitor System (CMS) by Rear-View Camera (RVC) to avoid misunderstanding between UN-R46 and this regulation

Japan Comment: Agreed. All description of CMS was replaced to RVC.

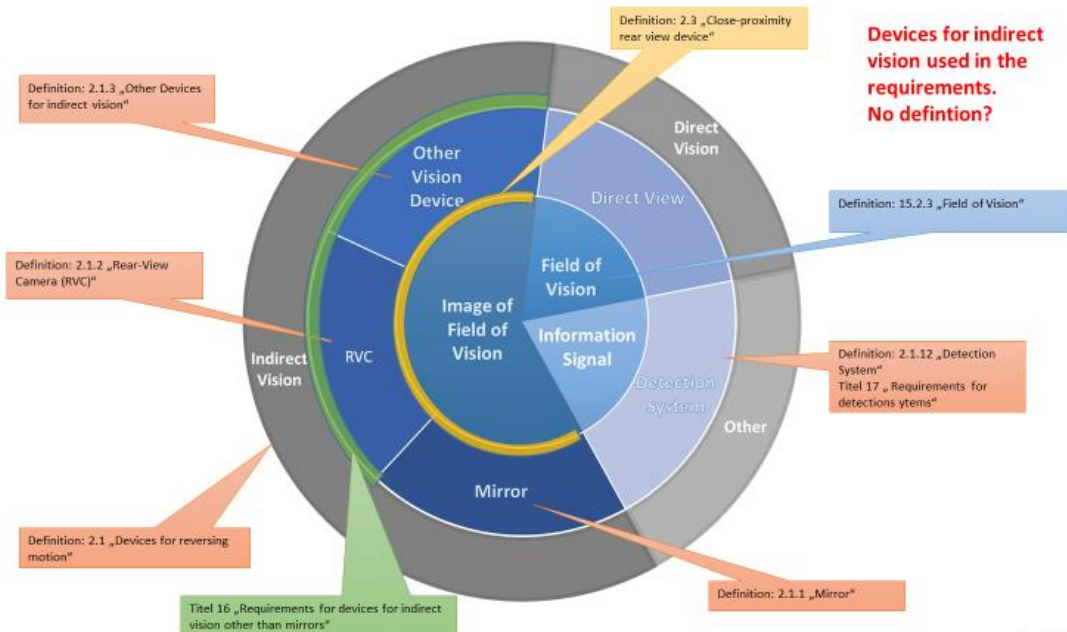

Understanding of some definitions used in the regulation

Japan Comment: This figure is matching intention of devices for this regulation.

For the purposes of this Regulation:

- 2.1. "Devices for reversing motion" means devices intended to give a clear view of the rear of the vehicle within the fields of vision defined in paragraph 15.2.3. These can be conventional mirrors, **Rear-View Camera** or other devices able to present information about the field of vision to the driver.
- 2.1. "Devices for indirect vision" means devices that present visual information of the fields of vision defined in paragraph 15.2.3.

Japan Comment: Added..

- 2.1.1. "Mirror" means any device, excluding devices such as periscopes, intended to give a clear view to the rear of the vehicle within the fields of vision defined in paragraph 15.2.3. by means of a reflective surface.
 - 2.1.1.1. "Interior mirror" means a device as defined in paragraph 2.1.1. above, which can be fitted in the passenger compartment of a vehicle.

OICA Justification: not used

Japan Comment: Agreed.

- 2.1.1.2. "Exterior mirror" means a device as defined in paragraph 2.1.1. above, which can be mounted on the external surface of a vehicle.

OICA Justification: not used

Japan Comment: Basically agreed. (Used only in Impact test section).

- 2.1.1.3. "Surveillance mirror" means a mirror other than the ones defined in paragraph 2.1.1. above which can be fitted to the inside or outside of the vehicle in order to provide fields of vision other than those specified in paragraph 15.2.3. of this Regulation.

Justification: see 1.5

Japan Comment: Agreed.

2.1.1.4. "r" means the average of the radii of curvature measured over the reflecting surface, in accordance with the method described in Annex 7.

2.1.1.5. "The radius of curvature at one point on the reflecting surface (r_p)" means the arithmetical average of the principal radii of curvature r_1 and r_1' , i.e.:

$$r_p = \frac{r_1 + r_1'}{2}$$

2.1.1.6. "Spherical surface" means a surface, which has a constant and equal radius in all directions.

2.1.1.7. "Aspherical surface" means a surface, which has only in one plane a constant radius.

2.1.1.8. "Aspherical mirror" means a mirror composed of a spherical and an aspherical part, in which the transition of the reflecting surface from the spherical to the aspherical part has to be marked. The curvature of the main axis of the mirror is defined in the x/y coordinate system defined by the radius of the spherical primary calotte with:

$$y = R - \sqrt{(R^2 - x^2)} + k(x - a)^3$$

Where:

R: nominal radius in the spherical part

k: constant for the change of curvature

a: constant for the spherical size of the spherical primary calotte

2.1.1.9. "Centre of the reflecting surface" means the centre of the visible area of the reflecting surface.

2.1.1.10. "The radius of curvature of the constituent parts of the mirror" means the radius "c" of the arc of the circle which most closely approximates to the curved form of the part in question.

~~2.1.2. "Camera monitor system (CMS)" means a device for indirect vision as defined in paragraph 2.1., where the field of vision is obtained by means of a camera-monitor combination as defined in paragraphs 2.1.2.1. and 2.1.2.2. below.~~

~~2.1.2.1. "Camera" means a device that renders an image of the outside world and then converts this image into a signal (e.g. video signal).~~

~~2.1.2.2. "Monitor" means a device that converts a signal into images that are rendered into the visual spectrum.~~

OICA Justification: to avoid misunderstanding with CMS definition in UN-R46 (see comments in §2). CMS removed and replaced in the document.

Japan Comment: Agreed.

2.1.3. "Other devices for indirect vision" means devices as defined in paragraph 2.1. above, where the field of vision is not obtained by means of a mirror or a **Rear-View Camera** device.

2.1.4. "Luminance contrast" means the brightness ratio between an object and its immediate background/surrounding that allows the object to be distinguished from its background/surroundings. The definition is in accordance with the definition given in ISO 9241-302:2008.

- 2.1.5. "Resolution" means the smallest detail that can be discerned with a perceptual system, i.e. perceived as separate from the larger whole. The resolution of the human eye is indicated as "visual acuity".
- 2.1.6. "~~Critical~~ Test object" means a cylindrical object with a height of 0.8 m and a diameter of 0.30 m.

OICA Justification: We replaced "critical" by "test" to avoid misunderstanding with critical object from UN-R46.

Japan Comment: Agreed. All description of "critical object" was replaced to "test object".

- ~~2.1.7. "Critical perception" means the level of perception that can just be obtained under critical conditions via the viewing system used. This corresponds to the situation in which the representative scale of the test object is multiple times larger than the smallest detail that can be perceived via the viewing system.~~

Japan Comment: Used part (16.2) to be removed.

- 2.1.8. "Field of vision" means the section of the tri-dimensional space on ground level which is monitored with the help of a device for indirect vision. Unless otherwise stated, this is based on the view offered by a device and/or devices other than mirrors. This may be limited by the relevant detection distance corresponding to the test object.

- ~~2.1.9. "Detection distance" means the distance measured from the centre of the lens of the camera to the point at which a Critical object can just be perceived (as defined by the critical perception).~~

OICA Justification: "detection distance" is used too in annex 12 – 2.1.1 regarding requirement for detection systems.

And In annex 12 – 2.1.1, the definition of Detection distance is from ISO that defines the detection area dimensions. It is not the same as in 2.1.9 taken from UN-R46 for CMS. Detection distance in 2.1.9 is used for "critical perception". Do we really need that definition (that is only used in the communication form) considering that we have requirements of what should be seen in the FoV?

Japan Comment: Agreed to remove.

- 2.1.10. "Visual spectrum" means light with a wavelength within the range of the perceptual limits of the human eyes: 380-780 nm.
- 2.1.11. "Smear" is a bright line displayed on the monitor while sun light or light from other bright light sources is directly hitting into the lens of the camera.
- 2.1.12. "Detection System" means a system which uses signals to enable the driver to detect objects in the area adjacent to the vehicle. ~~This system shall fulfil the provisions of paragraph 17. and Annex 12.~~

OICA Justification: the last sentence is not really a definition. The sentence is not necessary,

Japan Comment: Agreed to remove.

- 2.1.13. "Audible information" means information using auditory signals provided by a detection system as defined in paragraph 2.1.12. above to enable the driver to detect objects in the area adjacent to the vehicle. ~~This system shall fulfil the provisions of Annex 12.~~

OICA Justification: the last sentence is not really a definition. The sentence is not necessary,

Japan Comment: Agreed to remove.

- 2.1.14. "Optical information" means information using optical signals provided by a detection system as defined in paragraph 2.1.12. above to enable the driver to

detect objects in the area adjacent to the vehicle. ~~This system shall fulfil the provisions of Annex 12.~~

OICA Justification: the last sentence is not really a definition. The sentence is not necessary.

Japan Comment: Agreed to remove.

- [2.1.15. "Haptic information" means information using haptic signals provided by a detection system as defined in paragraph 2.1.12. above to enable the driver to detect objects in the area adjacent to the vehicle. ~~This system shall fulfil the provisions of Annex 12.~~]

OICA Justification: the last sentence is not really a definition. The sentence is not necessary

- ~~[2.1.15. "Haptic information" means information using haptic signals provided by a detection system as defined in paragraph 2.1.12. above to enable the driver to detect objects in the area adjacent to the vehicle. This system shall fulfil the provisions of Annex 12.]~~

Japan Comment: Proposal to remove. From HMI point of view, haptic information can't secure the same context provision like visual or audible information. Because it depends on human body contact condition. And, also detection system for reversing motion was validated only audible information in our study.

- 2.2. "Type of device ~~device for indirect vision~~ " means devices that do not differ on the following essential characteristics:
- (a) Design of the device inclusive, if pertinent, the attachment to the bodywork;
 - (b) In the case of mirrors, ~~the class,~~ the shape, the dimensions and radius of curvature of the mirror's reflecting surface;
 - (c) In the case of ~~Rear-View Camera,~~ ~~the class,~~ the field of view, the magnification ~~and resolution.~~
 - (d) In the case of detection systems, the sensor type, the information signal type.

OICA Justification:

Resolution to be deleted as no resolution requirement

Japan Comment: Agreed. Resolution requirements (16.1.3) to be removed.

(d) to consider detection system type and to avoid misunderstanding about "device for indirect vision" (what is included?)

Japan Comment: Agreed. "Type of device ~~device for indirect vision~~ " to corrected to "Type of device *for reversing safety*".

- 2.3. "Close-proximity rear-view device" means a device that gives the field of vision defined in **paragraph 15.2.3** of this Regulation.

OICA Justification: to be in line with the updated section 15 (that make the requirements clearer).

Japan Comment: Agreed. Details in 15.2.

3. Application for approval

- 3.1. The application for approval of a type of device for indirect vision shall be submitted by the holder of the trade name or mark or by his duly accredited representative.
- 3.2. A model of information document is shown in Annex 1.
- 3.3. For each type of device for indirect vision the application shall be accompanied by three samples of the parts.

- 3.4. The **RVC** shall be provided by the applicant with the following documents:
- (a) Technical specification of the **RVC**; and
 - (b) Operator's manual.

4. Markings

- 4.1. The samples of devices for indirect vision submitted for approval shall bear the trade name or mark of the manufacturer; this marking shall be clearly legible and be indelible.
- 4.2. Every device for indirect vision shall possess, on at least one of the main components, a space large enough to accommodate the approval mark, which shall be legible; this space shall be shown on the drawings referred to in Annex 1. The approval mark shall also be legible when the device is mounted on the vehicle with the exception of **Rear-View Camera** as defined in paragraph 2.1.2. or a detection system as defined in paragraph 2.1.12. Other components of the device shall bear a means of identification. In the case of limited space for the approval mark(s), other means of identification that link it to the approval mark shall be provided.

5. Approval

- 5.1. If the samples submitted for approval meet the requirements of paragraph 6. of this Regulation, approval of the pertinent type of device for indirect vision shall be granted.
- 5.2. An approval number shall be assigned to each type approved. Its first two digits (at present 00) shall indicate the series of amendments incorporating the most recent major technical amendments made to the Regulation at the time of issue of the approval. The same Contracting Party shall not assign the same number to another type of device for indirect vision.
- 5.3. Notice of approval or of refusal or of extension or withdrawal of approval or of production definitively discontinued of a type of device for indirect vision pursuant to this Regulation shall be communicated to the Parties to the Agreement which apply this Regulation by means of a form conforming to the model in Annex 3 to this Regulation.
- 5.4. There shall be affixed, on at least one of the main components, conspicuously and in the space referred to in paragraph 4.2. above, to every device for indirect vision, conforming to a type approved under this Regulation, in addition to the mark prescribed in paragraph 4.1. above, an international approval mark consisting of:
- 5.4.1. A circle surrounding the letter "E" followed by:
- (a) the distinguishing number of the country which has granted approval;² and
 - (b) the number of this Regulation, followed by the letter "R", a dash and the approval number.
- 5.5. The approval mark and the additional symbol(s) shall be clearly legible and be indelible.

² The distinguishing numbers of the Contracting Parties to the 1958 Agreement are reproduced in Annex 3 to the Consolidated Resolution on the Construction of Vehicles (R.E.3), document ECE/TRANS/WP.29/78/Rev.6 - www.unece.org/trans/main/wp29/wp29wgs/wp29gen/wp29resolutions.html

- 5.6. Annex 5 to this Regulation gives an example of the arrangement of the aforesaid approval mark and additional symbol.

6. Requirements

- 6.1. Close-proximity rear-view mirrors
- 6.1.1. General specifications
- 6.1.1.1. All mirrors shall be adjustable.
- 6.1.1.2. Mirrors installed outside the vehicles shall comply with sub-paragraph (a) and mirrors installed inside the vehicle shall comply with sub-paragraph (b).
- (a) Outside rear-view mirrors
- The edge of the reflecting surface shall be enclosed in a protective housing (holder, etc.) which, on its perimeter, shall have a value "c" greater than or equal to 2.5 mm at all points and in all directions. If the reflecting surface projects beyond the protective housing, the radius of curvature "c" on the edge of the projecting part shall be not less than 2.5 mm and the reflecting surface shall return into the protective housing under a force of 50 N applied to the point of greatest projection, relative to the protective housing, in a horizontal direction, approximately parallel to the longitudinal median plane of the vehicle.
- (b) Inside rear-view mirrors
- In cases where the edge of the reflecting surface is enclosed in a protective housing (holder, etc.), the radius of curvature "c" on its perimeter shall be not less than 2.5 mm at all points and in all directions. In cases where the edge of the reflecting surface projects beyond the protective housing, this requirement shall apply to the edge of the projecting part.
- [6.1.1.3. When the mirror is mounted on a plane surface, all parts, irrespective of the adjustment position of the device, including those parts remaining attached to the support after the test provided for in paragraph 6.3.2. below, which are in potential, static contact with a sphere either:
- (a) for a mirror installed inside the vehicle: 165 mm in diameter; or
- (b) for a mirror installed outside the vehicle, 100 mm in diameter;
- shall have a radius of curvature 'c' of not less than 2.5 mm.]

OICA Justification: 6.1.1.3 refers to 6.3.2 that is suggested to be deleted.

Japan Comment: Impact Test part (6.3) was agreed to be [] and ask CP's opinion in GRSG in last IWG.

We think keep this part (edge conditions) even if Impact Test part removed.

- 6.1.1.4. The requirements in paragraphs 6.1.1.2. [and 6.1.1.3. above] shall not apply to parts of the external surface which protrude less than 5 mm, but the outward facing angles of such parts shall be blunted, save where such parts protrude less than 1.5 mm. For determining the dimension of the projection, the following method shall apply:

OICA Justification: 6.1.1.4 refers to 6.1.1.3 that is suggested to be deleted.

Japan Comment: Impact Test part (6.3) was agreed to be [] and ask CP's opinion in GRSG in last IWG.

We think keep this part (edge conditions) even if Impact Test part removed.

- 6.1.1.4.1. The dimension of the projection of a component which is mounted on a convex surface may be determined either directly or by reference to a drawing of an appropriate section of this component in its installed condition.

- 6.1.1.4.2. If the dimension of the projection of a component which is mounted on a surface other than convex cannot be determined by simple measurement, it shall be determined by the maximum variation of the distance of the centre of a 100 mm diameter sphere from the nominal line of the panel when the sphere is moved over and is in constant contact with that component. Figure 1 shows an example of the use of this procedure.

Figure 1

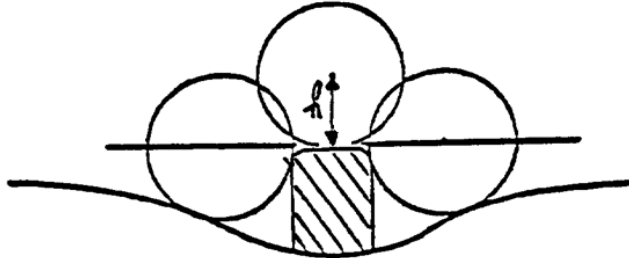
Example for the measurement by maximum variation

- 6.1.1.5. Edges of fixing holes or recesses of which the diameter or longest diagonal is less than 12 mm are exempt from the radius requirements of paragraph 6.1.1.3. above provided that they are blunted.
- 6.1.1.6. The device for the attachment of mirrors to the vehicle shall be so designed that a cylinder with a 70 mm radius (50 mm in the case of an L-category vehicle), having as its axis the axis, or one of the axes, of pivot or rotation which ensures deflection of the mirror in the direction of impact concerned, passes through at least part of the surface to which the device is attached.
- 6.1.1.7. The parts of Close-proximity rear-view mirrors installed outside the vehicle referred to in paragraphs 6.1.1.2. and 6.1.1.3. above which are made of a material with a Shore A hardness not exceeding 60 are exempt from the relevant provisions.
- 6.1.1.8. In the case of parts of Close-proximity rear-view mirrors installed inside the vehicle which are made of a material with a Shore A hardness of less than 50 and which are mounted on a rigid support, the requirements of paragraphs 6.1.1.2. and 6.1.1.3. above shall only apply to the support.
- 6.1.2. Special specifications
- 6.1.2.1. Dimensions
- 6.1.2.1.1. Close-proximity rear-view mirrors
- The contours of the reflecting surface shall be of simple geometric form and its dimensions such that the mirror provides the field of vision specified in paragraph 15.2.3. of this Regulation.
- 6.1.2.2. Reflecting surface and coefficients of reflection
- 6.1.2.2.1. The reflecting surface of a mirror shall be either flat or spherically convex. Exterior mirrors may be equipped with an additional aspherical part provided that the main mirror fulfils the requirements of the indirect field of vision.
- 6.1.2.2.2. Differences between the radii of curvature of mirrors
- 6.1.2.2.2.1. The difference between r_i or r'_i , and r_p at each reference point shall not exceed 0.15 r.
- 6.1.2.2.2.2. The difference between any of the radii of curvature (r_{p1} , r_{p2} , and r_{p3}) and r shall not exceed 0.15 r.
- 6.1.2.2.2.3. When r is not less than 3,000 mm, the value of 0.15 r quoted in paragraphs 6.1.2.2.2.1. and 6.1.2.2.2.2. above is replaced by 0.25 r.

- 6.1.2.2.3. Requirements for aspherical parts of mirrors
 - 6.1.2.2.3.1. Aspherical mirrors shall be of sufficient size and shape to provide useful information to the driver. This normally means a minimum width of 30 mm at some point.
 - 6.1.2.2.3.2. The radius of curvature r_i of the aspherical part shall not be less than 150 mm.
 - 6.1.2.2.4. The value of the normal coefficient of reflection, as determined according to the method described in Annex 6, shall be not less than 40 per cent.

In the case of reflecting surfaces with a changeable degree of reflection, the "day" position shall allow the colours of the signals used for road traffic to be recognized. The value of the normal coefficient of reflection in the "night" position shall be not less than 4 per cent.
 - 6.1.2.2.5. The reflecting surface shall retain the characteristics laid down in paragraph 6.1.2.2.4. above in spite of prolonged exposure to adverse weather conditions in normal use.
- 6.2. Close-proximity rear-view devices for indirect vision other than mirrors
 - 6.2.1. General requirements
 - 6.2.1.1. If adjustment by the user is needed, the device for indirect vision shall be adjustable without the use of tools.

OICA Comment: such requirement taken from UN-R46 is relevant? We try simplify the regulation as much as possible for a good understanding and reading.

- 6.2.1.2. The effectiveness of the **RVC** and other vision supporting devices of Close-proximity rear-view shall not be adversely affected by magnetic or electrical fields. This shall be demonstrated by compliance with the technical requirements and transitional provisions of UN Regulation No. 10, 05 series of amendments or any later series of amendments.

6.2.2. **Rear-View Camera**

The requirements of paragraph 6.2.2.1. shall be considered to be satisfied in the case of monitors of a vehicle that fulfills the provisions of UN Regulation No. 21.

The requirements of paragraph 6.2.2.1. shall be considered to be satisfied in the case of cameras of a vehicle that fulfills the provisions of UN Regulation No. 26.

OICA Comment: for projections and radius of curvature, we shall have general requirements (6.x requirements to be created) whatever is the system (mirror or CMS, or other, or detection). We shall distinguish requirements for Close-proximity rear-view devices inside or outside the vehicle. That will simplify the regulation. We may follow that articulation for a better reading.

- 1- List the requirements inside and outside separately.
- 2- Indicate that UN-R21 or 26 or 61 (ext.) may be equivalent.

We should do the same for installation.

6.2.2.1. General requirements

6.2.2.1.1. When the devices of the **Rear-View Camera** are mounted in the position recommended by the manufacturer for normal driving, all parts, irrespective of the adjustment position of the device which are in potential, static contact with a sphere either 165 mm in diameter in the case of a **RVC** or parts of **RVC** installed inside the vehicle or 100 mm in diameter in the case of a **RVC** or parts of **RVC** installed outside the vehicle, shall have a radius of curvature "c" of not less than 2.5 mm.

6.2.2.1.2. Edges of fixing holes or recesses of which the diameter or longest diagonal is less than 12 mm are exempt from the radius requirements of paragraph 6.2.2.1.1. above provided that they are blunted.

6.2.2.1.3. For parts of the **Rear-View Camera** which are made of a material with a Shore A hardness of less than 60 and which are mounted on a rigid support, the requirements of paragraph 6.2.2.1.1. above shall only apply to the support.

~~6.2.2.2. Functional requirements for camera monitor devices of Close proximity rear-view~~

~~6.2.2.2.1. The monitor shall render a minimum contrast under various light conditions as specified by ISO 15008:2003.~~

~~6.2.2.2.2. It shall be possible to adjust the average luminance of the monitor either manually or automatically to the ambient conditions.~~

~~6.2.2.2.3. The measurements for the luminance contrast of the monitor shall be carried out according to ISO 15008:2009.~~

Japan Comment: This part is remained part for CMS high specification.

6.2.3. Other devices for indirect vision

It has to be proved that the device meets the following requirements:

6.2.3.1. The device shall perceive the visual spectrum and shall always render this image without the need for interpretation into the visual spectrum.

OICA Comment: It is for other devices for indirect vision (radar, heat camera for instance).

We should be clear in definition section that other devices for indirect vision exclude mirror, RVC and all components approved in UN-R46.

[6.3. Test

The requirements of paragraph 6.3. shall be considered to be satisfied in the case of monitors of a vehicle fulfilling the provisions of UN Regulation No. 21.

6.3.1. ~~Devices for indirect vision in~~ Close-proximity rear-view mirrors or **Rear-View**

Camera mounted with protrusion in outside of the vehicle shall be subjected to the tests described in paragraphs 6.3.2.1. and 6.3.2.2. below.

- 6.3.1.1. The test provided for in paragraph 6.3.2. below shall not be required in the case of Close-proximity rear-view exterior devices for indirect vision of which no part is less than 2 m from the ground, regardless of the adjustment position, when the vehicle is under a load corresponding to its maximum technically permissible mass.

This derogation also applies to the attachments of devices for indirect vision (attachment plates, arms, swivel joints, etc.) which are situated less than 2 m from the ground and which do not project beyond the overall width of the vehicle, measured in the transverse plane passing through the lowest mirror attachments or any other point forward of this plane if this configuration produces a greater overall width.

In such cases, a description specifying that the device for indirect vision shall be mounted so as to conform to the above-mentioned conditions for the positioning of its attachments on the vehicle shall be provided.

Where advantage is taken of this derogation, the arm shall be indelibly marked with the symbol

$$\frac{\Delta}{2m}$$

and the type approval certificate shall be endorsed to this effect.

- 6.3.2. Impact test

The test according to this paragraph is not to be carried out for devices integrated in the bodywork of the vehicle and providing a frontal deflecting area of an angle not more than 45° measured in relation to the longitudinal median plane of the vehicle, or devices not protruding more than 100 mm measured beyond the circumscribing bodywork of the vehicle according to UN Regulation No. 26, 03 series of amendments.

- 6.3.2.1. Description of the test rig

- 6.3.2.1.1. The test rig consists of a pendulum capable of swinging about two horizontal axes at right angles to each other, one of which is perpendicular to the plane containing the "release" trajectory of the pendulum.

The end of the pendulum comprises a hammer formed by a rigid sphere with a diameter of 165 ± 1 mm having a 5 mm thick rubber covering of Shore A hardness 50.

A device is provided which permits determination of the maximum angle assumed by the arm in the plane of release.

A support firmly fixed to the structure of the pendulum serves to hold the specimens in compliance with the impact requirements specified in paragraph 6.1.3.2.2.6. below.

Figure 2 below gives the dimensions (in mm) of the test rig and the special design specifications:

Figure 2

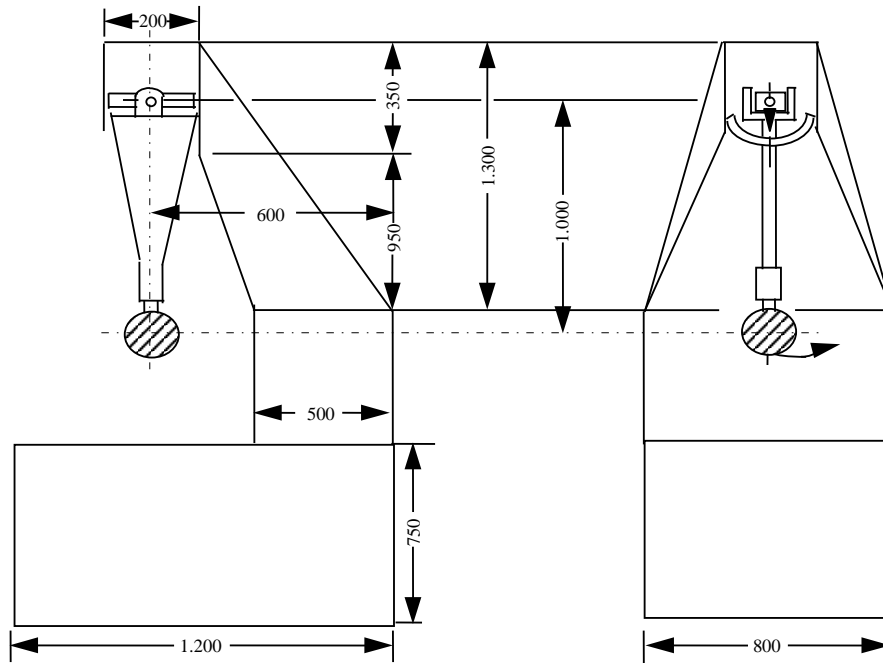

- 6.3.2.1.2. The centre of percussion of the pendulum coincides with the centre of the sphere, which forms the hammer. It is at a distance l from the axis of oscillation in the release plane, which is equal to $1 \text{ m} \pm 5 \text{ mm}$. The reduced mass of the pendulum is $m_o = 6.8 \pm 0.05$ kilograms. The relationship of m_o to the total mass m of the pendulum and to the distance d between the centre of gravity of the pendulum and its axis of rotation is expressed in the equation:

$$m_o = m \times \frac{d}{l}$$

- 6.3.2.2. Description of the test
- 6.3.2.2.1. The procedure used to clamp the device for indirect vision to the support shall be that recommended by the manufacturer of the device or, where appropriate, by the vehicle manufacturer.
- 6.3.2.2.2. Positioning of the device for indirect vision for the test
- 6.3.2.2.2.1. Devices for indirect vision shall be positioned on the pendulum impact rig in such a way that the axes which are horizontal and vertical when the mirror is installed on a vehicle in accordance with the applicant's mounting instructions are in a similar position;
- 6.3.2.2.2.2. When a device for indirect vision is adjustable with respect to the base, the test position shall be that in which any pivoting device is least likely to operate, within the limits of adjustment provided by the applicant;
- 6.3.2.2.2.3. When the device for indirect vision has a device for adjusting its distance from the base, the device shall be set in the position in which the distance between the housing and the base is shortest;
- 6.3.2.2.2.4. In the case of mirrors, when the reflecting surface is mobile in the housing, it shall be so adjusted that the upper corner, which is furthest from the vehicle, is in the position of greatest projection relative to the housing.
- 6.3.2.2.3. In the case of mirrors, when the pendulum is in a vertical position the horizontal and longitudinal vertical planes passing through the centre of the hammer shall pass through the centre of the reflecting surface as defined in paragraph 2.1.1.10. of this Regulation. The longitudinal direction of oscillation

of the pendulum shall be parallel to the longitudinal median plane of the vehicle.

- 6.3.2.2.4. In the case of **Rear-View Camera**, when the pendulum is in a vertical position the horizontal and longitudinal vertical planes passing through the centre of the hammer shall pass through the centre of the lens or of the transparent protection part protecting the lens. The longitudinal direction of oscillation of the pendulum shall be parallel to the longitudinal median plane of the vehicle. If the test is performed with a shutter camera system, the shutter has to be open during the pendulum impact.
- 6.3.2.2.5. When, under the conditions governing adjustment laid down in paragraphs 6.3.2.2.1. and 6.3.2.2.2. above parts of the device for indirect vision limit the return of the hammer, the point of impact shall be displaced in a direction perpendicular to the axis of rotation or pivoting in question.
- The displacement shall be no greater than is strictly necessary for the execution of the test; it shall be limited in such a way that:
- (a) Either the sphere delimiting the hammer remains at least tangential to the cylinder as defined in paragraph 6.1.1.6.;
 - (b) Or, in the case of mirrors, the point of contact with the hammer is located at least 10 mm from the periphery of the reflecting surface.
- 6.3.2.2.6. The test consists in allowing the hammer to fall from a height corresponding to a pendulum angle of 60° from the vertical so that the hammer strikes the device for indirect vision at the moment when the pendulum reaches the vertical position.
- 6.3.2.2.7. The devices for indirect vision are subjected to impact under the following different conditions:
- 6.3.2.2.7.1. Close-proximity rear-view mirrors
- (a) Test 1: The point of impact shall be as defined in paragraphs 6.3.2.2.3. or 6.3.2.2.5. above. The impact shall be such that the hammer strikes the mirror on the reflecting surface side;
 - (b) Test 2: The point of impact shall be as defined in paragraphs 6.3.2.2.3. or 6.3.2.2.5. above. The impact shall be such that the hammer strikes the mirror on the side opposite to the reflecting surface.
- 6.3.2.2.7.2. **Rear-View Camera**
- (a) Test 1: The point of impact shall be as defined in paragraphs 6.3.2.2.4. or 6.3.2.2.5. The impact shall be such that the hammer strikes the camera on the lens side;
 - (b) Test 2: The point of impact shall be as defined in paragraphs 6.3.2.2.4. or 6.3.2.2.5. The impact shall be such that the hammer strikes the camera on the side opposite to the lens.

Where more than one camera is fixed to the same mounting, the above-mentioned tests shall be executed on the lower camera. Nevertheless, the Technical Service responsible for testing may repeat one or both of these tests on the upper camera if this is less than 2 m from the ground.

- 6.3.3. Results of the tests
- 6.3.3.1. In the tests described in paragraph 6.3.2. above, the pendulum shall continue to swing after impact in such a way that the projection of the position assumed by the arm on the plane of release makes an angle of at least 20° with the vertical. The accuracy of measurement of the angle shall be within $\pm 1^\circ$.
- 6.3.3.1.1. In the case of mirrors, this requirement is not applicable to mirrors stuck to the windscreen, in respect of which the requirement stipulated in paragraph 6.3.3.2. shall apply after the test.
- 6.3.3.2. In the case of mirrors, should the mounting of the mirror break during the tests described in paragraph 6.3.2. above for mirrors stuck to the windscreen, the part remaining shall not project beyond the base by more than 10 mm and the configuration remaining after the test shall satisfy the conditions laid down in paragraph 6.1.3. of this Regulation.
- 6.3.3.3. The reflecting surface shall not break during the tests described in paragraph 6.3.2. However, breakage of the reflecting surface will be allowed if one of the following conditions is fulfilled.
- 6.3.3.3.1. The fragments of glass still adhere to the back of the housing or to a surface firmly attached to the housing; partial separation of the glass from its backing is admissible provided that this does not exceed 2.5 mm on either side of the cracks. It is permissible for small splinters to become detached from the surface of the glass at the point of impact;
- 6.3.3.3.2. The reflecting surface is made of safety glass.
- 6.3.3.4. In the case of **Rear-View Camera**, the lens shall not break during the tests described in paragraph 6.3.2. above.]

Japan Comment: Impact Test part (6.3) was agreed to be [] and ask CP's opinion in GRSG in last IWG.

OICA Comment: The complete section 6.3 is not clear. What needs to be tested? Outside component, inside component?

Japan Comment: To make it clear, 6.3.1 corrected.

7. Modification of the type of device for reversing motion and extension of approval

- 7.1. Every modification to an existing type of device for indirect vision including its connection to the bodywork shall be notified to the Type Approval Authority which approved the type of device for indirect vision. The Type Approval Authority shall then either:
- (a) Decide, in consultation with the manufacturer, that a new type-approval is to be granted; or
 - (b) Apply the procedure contained in paragraph 7.1.1. (Revision) and, if applicable, the procedure contained in paragraph 7.1.2. (Extension).
- 7.1.1. Revision
- When particulars recorded in the information folder have changed and the Type Approval Authority considers that the modifications made are unlikely to have an appreciable adverse effect and that in any case the device for indirect

vision still complies with the requirements, the modification shall be designated a "revision".

In such a case, the Type Approval Authority shall issue the revised pages of the information folder as necessary, marking each revised page to show clearly the nature of the modification and the date of re-issue. A consolidated, updated version of the information folder, accompanied by a detailed description of the modification, shall be deemed to meet this requirement.

7.1.2. Extension

The modification shall be designated an "extension" if, in addition to the change of the particulars recorded in the information folder;

- (a) Further inspections or tests are required; or
- (b) Any information on the communication document (with the exception of its attachments) has changed; or
- (c) Approval to a later series of amendments is requested after its entry into force.

7.2. Confirmation or refusal of approval, specifying the alterations shall be communicated by the procedure specified in paragraph 5.3. above to the Parties to the Agreement which apply this Regulation. In addition, the index to the information package, attached to the communication document, shall be amended accordingly to show the date of the most recent revision or extension.

7.3. The Type Approval Authority issuing the extension of approval shall assign a series number to each communication form drawn up for such an extension.

8. Conformity of production

8.1. The conformity of production procedure shall comply with those set out in the Agreement, Schedule 1 (E/ECE/324-E/ECE/TRANS/505/Rev.3).

8.2. Every device for indirect vision approved under this Regulation shall be so manufactured as to conform to the type approved by meeting the requirements set out in paragraph 6. above.

9. Penalties for non-conformity of production

9.1. The approval granted in respect of a type of device for indirect vision pursuant to this Regulation may be withdrawn if the requirement laid down in paragraph 8.1. above is not complied with or if the type of device for indirect vision did not satisfy the requirements prescribed in paragraph 8.2. above.

9.2. If a Contracting Party to the Agreement which applies this Regulation withdraws an approval it has previously granted, it shall forthwith so notify the other Contracting Parties applying this Regulation by means of a copy of the communication form bearing at the end, in large letters, the signed and dated annotation "APPROVAL WITHDRAWN".

10. Production definitively discontinued

If the holder of the approval completely ceases to manufacture a type of device for indirect vision approved in accordance with this Regulation, he shall so inform the Type Approval Authority which granted the approval. Upon receiving the relevant communication, the Authority shall inform thereof the other Parties to the Agreement applying this Regulation by means of a copy of the approval form bearing at the end, in large letters, the signed and dated annotation "PRODUCTION DISCONTINUED".

11. Names and addresses of Technical Services responsible for conducting approval tests, and of Type Approval Authorities

The Contracting Parties to the Agreement applying this Regulation shall communicate to the United Nations Secretariat the names and addresses of the Technical Services responsible for conducting approval tests and of the Type Approval Authorities which grant approval and to which forms certifying approval or refusal or extension or withdrawal of approval, issued in other countries, are to be sent.

Part II - Installation of devices for reversing motion

12. Definitions

For the purpose of this Regulation:

- 12.1. "The driver's ocular points" means two points 65 mm apart and 635 mm vertically above point R of the driver's seat as defined in Annex 8. The straight line joining these points runs perpendicular to the vertical longitudinal median plane of the vehicle. The centre of the segment joining the two ocular points is in a vertical longitudinal plane which shall pass through the centre of the driver's designated seating position, as specified by the vehicle manufacturer.
- 12.2. "Ambinocular vision" means the total field of vision obtained by the superimposition of the monocular fields of the right eye and the left eye (see Figure 2 below).

Figure 2

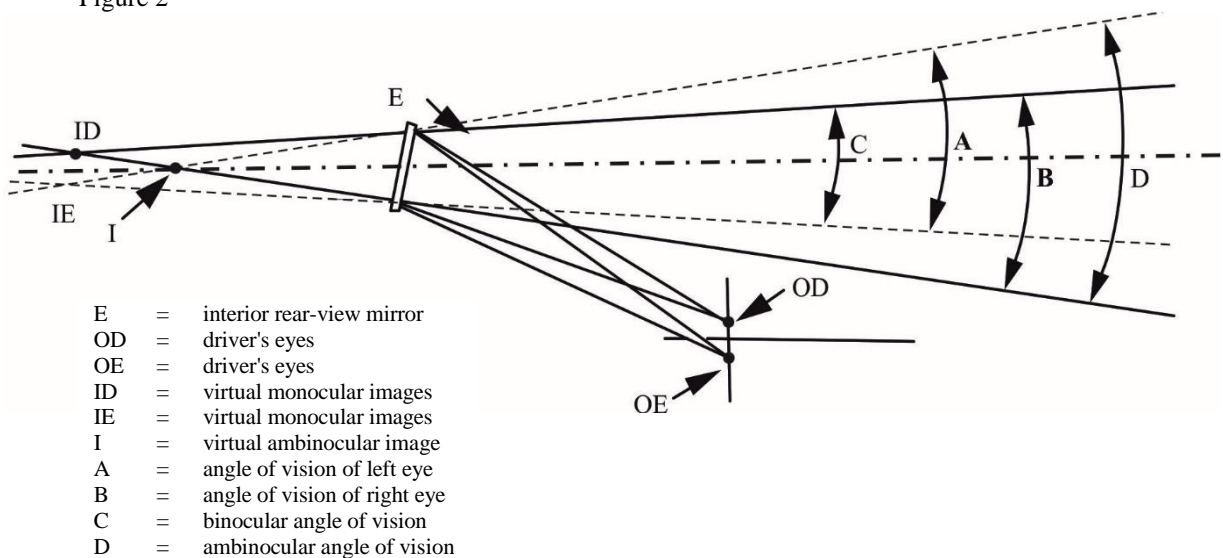

- 12.3. "Type of vehicle as regards ~~indirect vision~~ to the driver's awareness of vulnerable road users behind vehicles " means motor vehicles which are identical in respect of the following basic features:

[OICA Justification](#): to be in line with regulation wording/title.

[Japan Comment](#): Agreed.

- 12.3.1. Type of device ~~for indirect vision~~;

[OICA Justification](#): to include the detection system.

[Japan Comment](#): To be corrected to "device for reversing safety".

- 12.3.2. The bodywork features which reduce the field of vision;
- 12.3.3. The coordinates of point R (where applicable);
- 12.3.4. The prescribed positions, and type-approval markings of compulsory and (if fitted) optional devices for indirect vision.
- 12.4. "*Vehicles of categories M₁, M₂, M₃, N₁, N₂ and N₃*" means those defined in the Consolidated Resolution on the Construction of Vehicles (R.E.3), (document ECE/TRANS/WP.29/78/Rev.6).
- 12.5. "*Forward control*" means a configuration in which more than half of the engine length is rearward of the foremost point of the windshield base and the steering wheel hub in the forward quarter of the vehicle length.
- ~~12.5. "*Forward control*" means a configuration in which more than half of the engine length is rearward of the foremost point of the windshield base and the steering wheel hub in the forward quarter of the vehicle length.~~

OICA Justification: only used in annex 2 and not affect forward rear view devices. It is for Class VI devices.

Japan Comment: Agreed to remove.

- 12.6. "*Ocular reference point*" means the middle point between the driver's ocular points.
- 12.7. "*Backing event*" means an amount of time from start and ends of reversing motion as described in 15.1.3. in this Regulation.
- 12.8. "*The driver's looking-back ocular points*" means two points located at 96 mm longitudinally rearward, 158 mm horizontally inside to vehicle centre direction and 6 mm vertically above from "the driver's ocular points" described in paragraph 12.1.

OICA Justification: Moved from 15.2.3.1.5 to that section.

Japan Comment: Agreed to move.

- 12.9** "*Active vehicle mode*" means the vehicle mode when:
- Application of pressure to the accelerator pedal (or activation of an equivalent control) or release of the brake system will cause the power train to move the vehicle, and
 - All the systems and components are fully Booted Up & Active.

OICA Justification: to be in line with 15.1.1 (backing event start)

13. Application for approval

- 13.1. The application for approval of a vehicle type with regard to the installation of devices for indirect vision shall be submitted by the vehicle manufacturer or by his duly accredited representative.

OICA Comment: to be updated according to definitions updates.

- 13.2. A model of information document is shown in Annex 2.
- 13.3. A vehicle representative of the vehicle type to be approved shall be submitted to the Technical Service responsible for conducting the approval tests.
- 13.4. The Type Approval Authority shall verify the existence of satisfactory arrangements for ensuring effective checks on conformity of production before type-approval is granted.
- 13.5. The **RVC** shall be provided by the applicant with the following documents:
- (a) Technical specification of the **RVC**;
 - (b) Operator's manual.

14. Approval

- 14.1. If the vehicle type submitted for approval in accordance with paragraph 13. above meets the requirements of paragraph 15. of this Regulation, approval shall be granted.
- 14.2. An approval number shall be assigned to each type approved. Its first two digits (at present 00) shall indicate the series of amendments incorporating the most recent or technical amendments made to the Regulation at the time of issue of the approval. The same Contracting Party shall not assign the same number to another vehicle type.
- 14.3. Notice of approval or of refusal or of extension or withdrawal of approval of a vehicle type pursuant to this Regulation shall be communicated to the Parties to the Agreement which apply this Regulation by means of a form conforming to the model in Annex 4 to this Regulation.

15. Requirements

- 15.1. General

Japan Comment: Agreed to change structure proposed by OICA that make it clear.

For the purpose of this Regulation, the vehicle shall fulfil the following requirements:

During a backing event at least one means of vision or awareness shall be provided to the driver.

Means of vision provide a close-proximity rear-view field of vision as defined in paragraph 15.2 below. Possible means are :

- (a) **Direct vision,**
- (b) **Devices approved to UN Regulation No. 46,**
- (c) **Close Proximity Rearview Mirror complying with this Regulation,**
- (d) **Rear View Camera System complying with this Regulation.**

Means of Awareness provide an information other than vision for the close-proximity rear monitoring area as defined in paragraph 15.3 below. Possible means are :

- (a) **Detection System complying with this Regulation.**

- 15.1.1 Backing event starts when the vehicle is **in Active vehicle mode** and the vehicle's direction selector is placed **from forward or neutral** in reverse by the driver or a system, and ends at the manufacturer's choosing, when the vehicle forward motion reaches:

- (a) a speed of 16 km/h, **or**
- (b) a distance of 10 meters travelled, **or**
- (c) a continuous duration of 10 seconds, **or**
- (d) the vehicle's direction selector is not placed in reverse.

- 15.2 Close Proximity Rear-View Field of Vision:

The field of vision shall be bounded by the following planes:

- (a) A transverse vertical plane passing through a point 300 mm from the outermost point of the rear of the vehicle;
- (b) A transverse vertical plane passing through a point 3,500 mm behind the outermost point of the rear of the vehicle;

(c) Two longitudinal vertical planes parallel to the longitudinal vertical median plane passing through the outermost point of each side of the vehicle.

The height of the field of vision is defined at nine positions within the boundaries of the field of vision with test objects with a height of 800 mm and a diameter of 300 mm which are located on the ground plane as defined in Figure 3 below:

Figure 3
Close-proximity rear-view field of vision

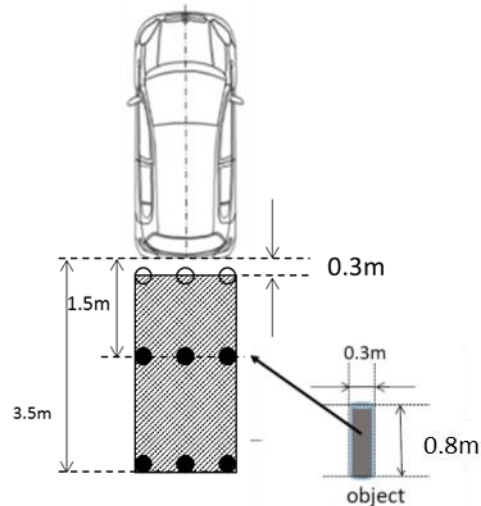

- 15.2.1** When tested under the conditions defined in Annex 11 the requirement for close-proximity rear-view field of vision shall be considered to be satisfied if the defined field of vision can be seen:
- 15.2.1.1** via the direct view from the driver's looking back ocular points; or
 - 15.2.1.2** via the direct view from the driver's looking back ocular points combined with a close-proximity rear-view mirror installed at the rear end of the vehicle supporting this direct view; or
 - 15.2.1.3** via a device of indirect vision (mirror or CMS or other) approved to UN Regulation No. 46; or
 - 15.2.1.4** via a device of indirect vision (mirror or RVC or other) complying with this Regulation; or
 - 15.2.1.5** via a combination of devices of paragraphs 15.2.1.3 and 15.2.1.4.

§	UN-R 46 mirror	UN-R 46 CMS	Close prox. Rear view mirror	Close prox. Rear view camera (RVC)	Direct view	Detection system
15.2.1.3	X					
15.2.1.3		X				
15.2.1.3	X	X				
15.2.1.5	X		X			
15.2.1.5		X	X			
15.2.1.5	X	X	X			
15.2.1.5	X			X		
15.2.1.5		X		X		
15.2.1.5	X	X		X		
15.1						X
15.2.1.1					X	
15.2.1.2			X		X	
15.2.1.4			X			
15.2.1.4				X		
15.2.1.4			X	X		

Confidential C

15.2.2 The close-proximity rear-view field of vision shall be established using ambinoocular vision, the eyes being at the "driver's ocular points" as defined in paragraph 12.1. above. The fields of vision shall be determined when the vehicle is in running order as defined in the consolidated Resolution on the Construction of vehicles (R.E.3) (ECE/TRANS/WP.29/78/Rev.6, para. 2.2.5.4.), plus for M1 and N1 vehicles one front seat passenger (75 kg). When established through windows, the glazing shall have a total light transmission factor in accordance with UN Regulation No. 43, Annex 21.

In case of direct view from the driver's looking back ocular points the vertical position of rear seat headrests shall be set at the designed position of assumed to use or the highest position if the headrest has multiple position settings or at the position agreed with the Technical Service.

15.2.3 In case of combination of devices, each transverse row of cylindrical objects shall be seen by one device. The close-proximity rear-view field of vision shall be obtained from the minimum number of mirrors and monitors.

15.2.4. Position

15.2.4.1. Devices for indirect vision shall be so placed that the driver, when sitting on the driving seat in a normal driving position, has a clear view of the road to the rear, side(s) or front of the vehicle.

15.2.4.3. In the case of any vehicle, which is in chassis/cab form when the field of vision is measured, the minimum and maximum body widths shall be stated by the manufacturer and, if necessary, simulated by dummy headboards. All vehicles and devices for indirect vision configurations taken into consideration during the tests shall be shown on the type-approval certificate for a vehicle with regard to the installation of devices for indirect vision (see Annex 4).

15.2.4.4. Devices for indirect vision shall not project beyond the external bodywork of the vehicle substantially more than is necessary to comply with the requirements concerning fields of vision they are designed for ~~laid down in paragraph 15.2.4. below.~~

15.2.4.5. Devices for indirect vision shall be fitted in such a way that the devices do not move so as significantly to change the field of vision as measured or vibrate to an extent which would cause the driver to misinterpret the nature of the image perceived.

- 15.2.5. In the case of mirrors consisting of several reflecting surfaces which are either of different curvature or make an angle with each other, at least one of the reflecting surfaces shall provide the field of vision and have the dimensions (~~paragraph 6.1.2.1.2.2. of this Regulation~~) specified for the class to which they belong.
- 15.3. Close-proximity rear monitoring area
- The monitoring area shall be bounded by the following planes (see figure 4):
- A transverse vertical plane passing through a point 200 mm from the outermost point of the rear of the vehicle;
 - A transverse vertical plane passing through a point 1,000 mm behind the outermost point of the rear of the vehicle;
 - Two longitudinal vertical planes parallel to the longitudinal vertical median plane passing through the outermost point of each side of the vehicle.

Figure 4
Close-proximity rear monitoring area

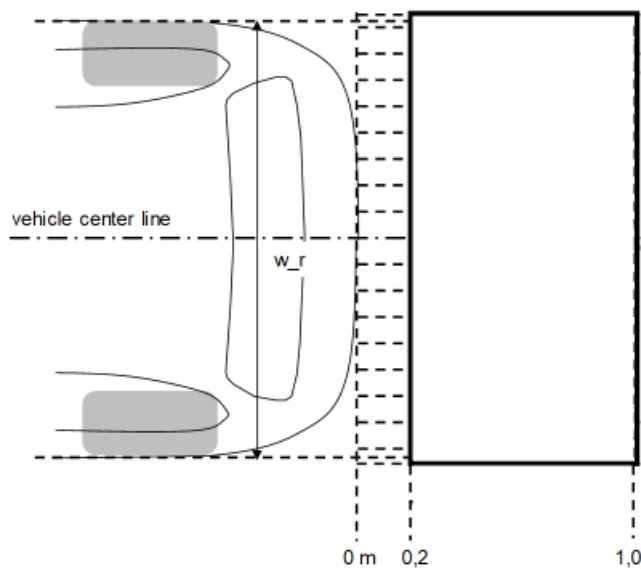

- 15.3.1 When tested under the conditions defined in Annex 12 the requirement for close-proximity rear monitoring area shall be considered to be satisfied if the information as defined in paragraph 17.2 is provided to the driver.

Explanation on concept:

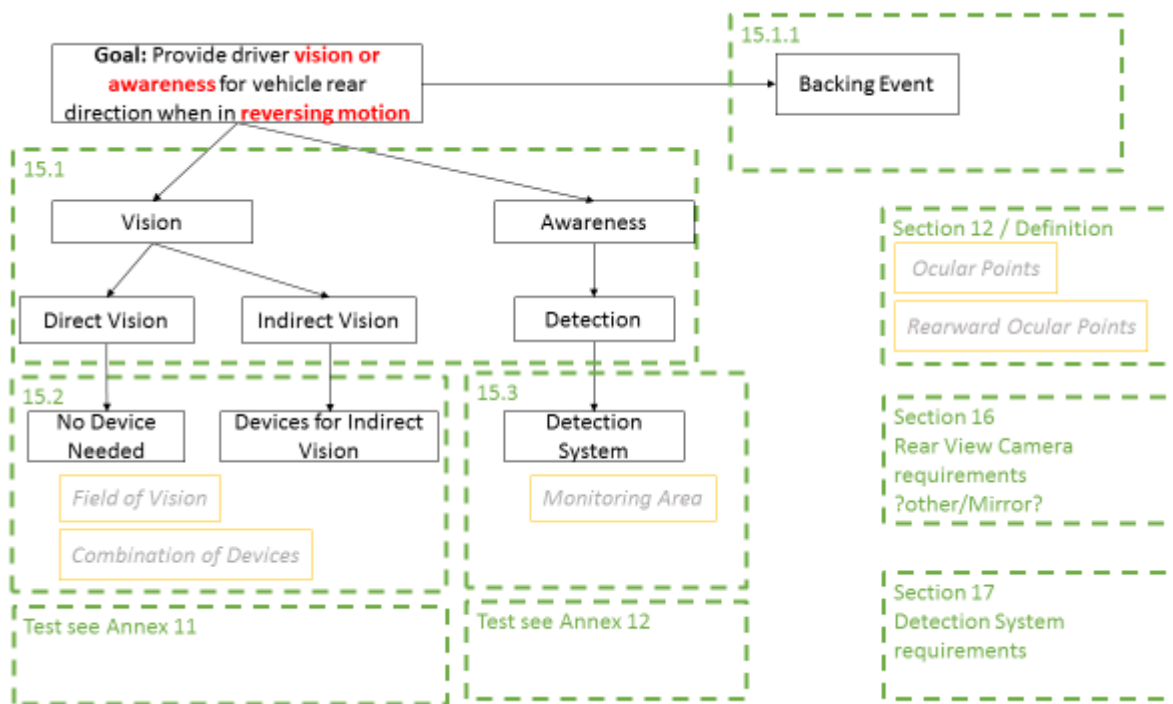

15.1.1. Devices for reversing motion shall be fitted in such a way that the devices do not move so as significantly to change the field of vision as measured or vibrate to an extent which would cause the driver to misinterpret the nature of the image perceived.

Japan Checked: Move to 15.2.4.5.

15.1.2. The fields of vision defined below shall be established using ambinocular vision, the eyes being at the "driver's ocular points" as defined in paragraph 12.1. above. The fields of vision shall be determined when the vehicle is in running order as defined in the consolidated Resolution on the Construction of vehicles (R.E.3) (ECE/TRANS/WP.29/78/Rev.6, para. 2.2.5.4.), plus for M₁ and N₁ vehicles one front seat passenger (75 kg). When established through windows, the glazing shall have a total light transmission factor in accordance with UN Regulation No. 43, Annex 21.

Japan Checked: Move to 15.2.2.

15.1.3 Backing event starts when the vehicle's direction selector is placed in reverse by the driver or a system, and ends at the manufacturer's choosing, when the vehicle forward motion reaches:

- (a) a speed of 16 km/h,
- (b) a distance of 10 meters travelled, or
- (c) a continuous duration of 10 seconds
- (d) the vehicle's direction selector is not placed in reverse.

Japan Checked: Move to 15.1.1.

15.2. Devices for reversing motion

15.2.1. Number

15.2.1.1. Minimum number of compulsory devices for indirect vision

15.2.1.1.1. The fields of vision prescribed in paragraph 15.2.3. shall be obtained from the minimum number of **mirrors or monitors** ~~devices for indirect vision (mirrors or camera monitor devices).~~

~~The minimum number of camera-monitor systems is undefined, but they shall provide the same field of vision and the provision on the minimum mounting height does not apply.~~

OICA Justification:

1-To be in line with comment in §2.

1-to be in line with the updated section 15 (that make the requirements clearer)

1- the intention of that requirement is to not have too many devices to look at. And in another requirement, 1 row, 1 device: so at the maximum 3 devices

2- The second paragraph is not necessary

Japan Comment: Agreed.

~~15.2.1.2. The provisions of this Regulation do not apply to the surveillance mirrors defined in paragraph 2.1.1.3. of this Regulation. Nevertheless, the exterior surveillance mirrors shall be mounted at least 2 m above the ground when the vehicle is under a load corresponding to its maximum technical permissible mass.~~

Justification: no more “surveillance mirrors” definition

Japan Comment: Agreed to remove.

15.2.2. Position

15.2.2.1. Devices for indirect vision shall be so placed that the driver, when sitting on the driving seat in a normal driving position, has a clear view of the road to the rear, side(s) or front of the vehicle.

Japan Checked: Move to 15.2.4.

~~15.2.2.2. Close proximity rear view mirrors shall be visible through the window(s) or through the portion of the windscreen that is swept by the windscreen wiper. Nevertheless, for design reasons, this last provision (i.e. the provision relating to the cleaned part of the windscreen) shall not apply to Close proximity rear view mirrors.~~

OICA Justification: is it possible to have clarifications regarding that requirement. It is not clear.

We propose to delete it

Japan Comment: Agreed to remove.

15.2.2.3. In the case of any vehicle, which is in chassis/cab form when the field of vision is measured, the minimum and maximum body widths shall be stated by the manufacturer and, if necessary, simulated by dummy headboards. All vehicles and devices for indirect vision configurations taken into consideration during the tests shall be shown on the type-approval certificate for a vehicle with regard to the installation of devices for indirect vision (see Annex 4).

15.2.2.4. Devices for indirect vision shall not project beyond the external bodywork of the vehicle substantially more than is necessary to comply with the requirements concerning fields of vision laid down in paragraph 15.2.4. below.

15.2.3. Fields of vision

15.2.3.1. Close-proximity rear-view devices

15.2.3.1.1. The field of vision shall be bounded by the following planes and shall be such that the driver can see the conditions defined in Annex 11. In this Regulation with a height of 800 mm and a diameter of 300 mm which is located on the ground plane at nine positions within the boundaries of the field of vision as defined in Figure 3 below:

(a) A transverse vertical plane passing through a point 300 mm from the outermost point of the rear of the vehicle;

(b) A transverse vertical plane passing through a point 3,500 mm behind the outermost point of the rear of the vehicle;

(c) Two longitudinal vertical planes parallel to the longitudinal vertical median plane passing through the outermost point of each side of the vehicle.

15.2.3.1.2. If the field of vision defined in paragraph 15.2.3.1.1. can be seen via a combination of devices for indirect vision of other Class(es) of devices for indirect vision, it is not mandatory to equip the vehicle with a close-proximity rear-view device.

In addition, the requirement may be met using a combination of Close-proximity rear-view mirrors and other Class(es) of devices fulfilling the provisions of UN Regulation No. 46, 04 series of amendments or using a detection system defined in 2.1.12. of this Regulation.

[15.2.3.1.3. If the field of vision defined in paragraph 15.2.3.1.1. can be fully seen via direct view from the driver's looking-back ocular points described in paragraph 15.2.3.1.5, it is not mandatory to equip the vehicle with a close-proximity rear view device according to this Regulation.

This requirement is also fulfilled if the vehicle is equipped with a Close-proximity rear-view mirror installed at the rear end of the vehicle supporting this direct view.]

15.2.3.1.4. If the field of vision defined in paragraph 15.2.3.1.1. can be seen directly by the driver, the vertical position of rear seat headrests shall be set at the designed position of assumed to use or the highest position if the headrest has multiple position settings or at the position agreed with the Technical Service.

Figure 3
Close-proximity rear-view field of vision

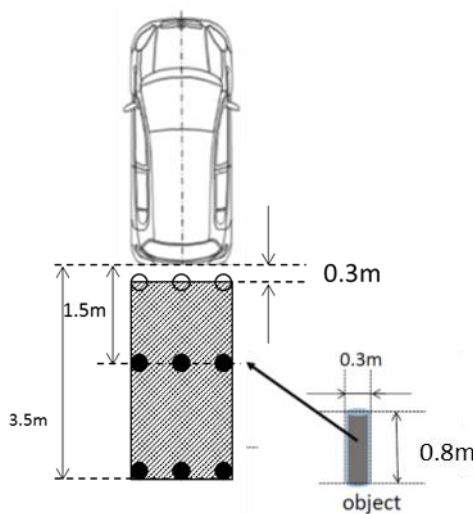

Japan Checked: Move to 15.2.

~~15.2.3.1.5. "The driver's looking-back ocular points" means two points located at 96 mm longitudinally rearward, 158 mm horizontally inside to vehicle centre direction and 6 mm vertically above from "the driver's ocular points" described in paragraph 12.1.~~

OICA Comment: Definitions should be in section 12!

Japan Comment: Agreed to move.

15.2.3.1.6. Each transverse row of cylindrical objects shall be seen by one device.

Japan Checked: Move to 15.2.3.

15.2.4.2. In the case of mirrors consisting of several reflecting surfaces which are either of different curvature or make an angle with each other, at least one of the reflecting surfaces shall provide the field of vision and have the dimensions (paragraph 6.1.2.1.2.2. of this Regulation) specified for the class to which they belong.

[Japan Checked: Move to 15.2.5.](#)

16. Requirements for devices for indirect vision other than mirrors

16.1. Intended use, activation and deactivation

The intended use shall be mentioned within the operator's manual. The procedure for activation and deactivation of the RVC shall allow a safe use of the vehicle.

Notwithstanding the provisions above, any other concept to activate or deactivate the system shall be demonstrated to the satisfaction of the Technical Service within the safety concept that is provided according to the provisions of UN Regulation No. 46, 04 series of amendments.

~~Notwithstanding the provisions above, any other concept to activate or deactivate the system shall be demonstrated to the satisfaction of the Technical Service within the safety concept that is provided according to the provisions of UN Regulation No. 46, 04 series of amendments.~~

OICA Comment: Safety concept from UN-R46 is not relevant for our regulation. All 16 requirements are part of the Safety concept (failure, deactivation.....)

So we propose to delete it and to have a more simple requirement at the end of section 16.

16.1.1.1. Default view

In default view the RVC shall show the field of view at least as defined in paragraph 15.2.3, with at least the required magnification and resolution as defined in paragraph 16.1.3.

The RVC must default to the rear-view image at the beginning of each backing event regardless of any modifications to the field of view that the driver has previously selected.

16.1.1.2. Luminance and contrast adjustment

If manual adjustment is provided, the operator's manual shall provide information on how to change the luminance/contrast.

16.1.1.3. Overlay requirements within the minimum required field of vision

Overlays shall display only rearward driving-related visual information or safety-related information. ~~Overlays for other purposes of information shall be considered as an obstruction regardless of their transparency.~~

OICA Justification: Are there requirements regarding obstruction?

16.1.1.4. Deactivation

The rear-view image shall remain visible during the backing event until either, the driver modifies the view, or the vehicle direction selector is removed from the reverse position.

Comment: What is the meaning of “modifying the view”?

For buses the same monitor may be used for view on the second door, possibly also while reversing (before opening the door).

16.1.1.5 Automatic change of view

When there is a risk of collision, the field of view may change and focus on the collision area. It shall be demonstrated to the Technical Service that this change of view increases the safety.

When the vehicle is not driving straight, the field of view may change following the vehicle trajectory.

[16.1.1.6. Automatic screen change

The default view may be automatically changed in the case of :
 - system failure as regularly off the reversing camera.]

16.1.2. Operating readiness (System availability)

Non-operation of the system shall be recognizable to the driver is (e.g. RVC failure by, i.e. warning indication, display information, absence of status indicator). The information for the driver shall be explained in the operator's manual.

[16.1.2.1. Response time

The rear-view image meeting the requirements described in 15.2.3. shall be displayed within 2.0 seconds when the backing event starts]

OICA Justification: to be in line with the updated section 15 (that make the requirements clearer)

Japan Comment: CLEPA support FMVSS condition (6 sec. Door open, 2 sec. reverse gear)

~~16.1.3. Resolution~~

~~16.1.3.1. Resolution (MTF)~~

~~The resolution (MTF) defines the minimum distinguishable details observable in an image as is represented by the MTF10. For reasons of simplicity the requirement is defined assuming an aspect ratio of 1:1.~~

~~Resolution MTF10, at the centre of the monitor defined size shall fulfil the following requirements:~~

~~———— $MTF10_{(1:1)/hor} \geq MTF10_{MIN(1:1)/hor}$, in horizontal direction,~~

~~———— $MTF10_{(1:1)/ver} \geq MTF10_{MIN(1:1)/ver}$, in vertical direction.~~

~~Resolution MTF10, at the corner measurement points as illustrated in the figure below shall fulfil the following requirements:~~

~~———— $MTF10_{(1:1)/hor} \geq \frac{1}{2} MTF10_{MIN(1:1)/hor}$, in horizontal direction,~~

~~———— $MTF10_{(1:1)/ver} \geq \frac{1}{2} MTF10_{MIN(1:1)/ver}$, in vertical direction,~~

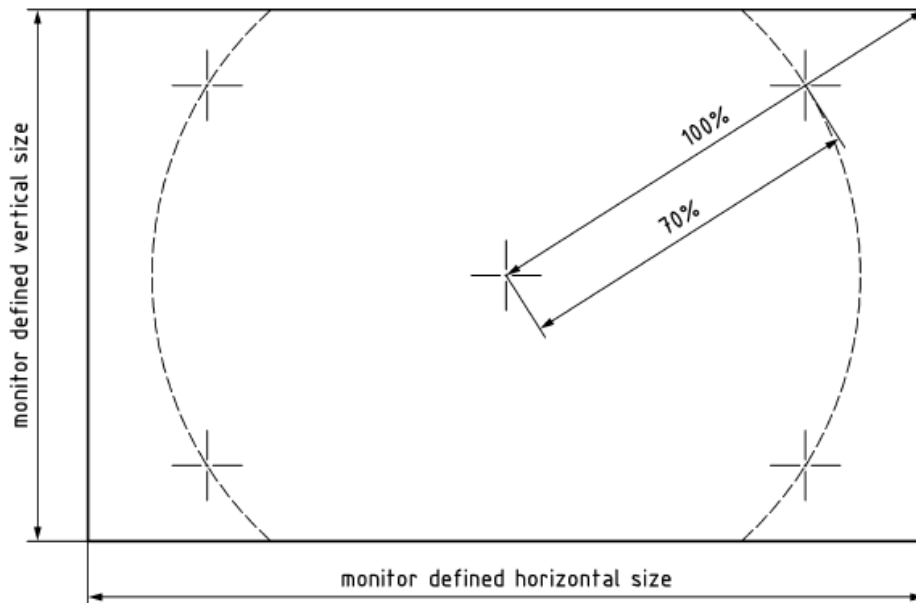

Japan Comment: To be removed, not fit rear-view camera that have fish-eye lens.

16.1.4. Monitor inside the vehicle

~~16.1.4.1. The centre of the monitor(s) shall not be below a plane passing through the driver's ocular points, as defined in paragraph 12.1., and declined 30° below.~~

~~16.1.4.2. The arrangement of the monitor(s) inside the vehicle shall be convenient to the driver.~~

~~Thus, the image of the right side field of view shall be presented to the right of the longitudinal vertical plane through the ocular reference point, defined in paragraph 12.6. The image of the left side field of view shall be presented to the left of the longitudinal vertical plane through the ocular reference point.~~

~~If the CMS shows more than one field of vision on one display, non-continuous images shall be clearly separated from each other. Provided that the required field of vision of different classes of devices for indirect vision are shown on the monitor(s) without hiding any part of the required field of vision, a combined continuous image without clear separation is allowed.~~

Japan Comment: These part are for Class II or III requirements.

16.1.4.1. The monitor defined size shall be visible without any obstruction from the ocular reference point. A virtual testing is acceptable.

16.1.5. Obstruction of the driver's direct view caused by the installation of a device for indirect vision shall be restricted to a minimum.

~~16.1.6. Decreasing accommodation~~

~~The installation of the monitor inside the vehicle should follow the needs of the intended user group. The operator's manual shall provide information on the decreasing capacity of the human being to accommodate and shall recommend suitable assistance for the user's needs.~~

~~16.1.7. Safety of electronic systems for indirect vision~~

~~The requirements to be applied to the safety aspects of electronic systems for indirect vision are given in Annex 11, paragraph 2.~~

Japan Comment: To be removed not needed.

16.2. Rear-View Camera

~~16.2.1. A device for indirect vision shall give such performances that a critical object can be observed by the driver over the entire required field of vision, taking into account the critical perception according the procedure of Annex 9.~~

~~Alternatively, the determination of the displayed object size shall be performed according to Annex 11.~~

~~16.2.2. Obstruction of the driver's direct view caused by the installation of a device for indirect vision shall be restricted to a minimum.~~

~~16.2.3. Installation requirements for the monitor~~

~~The viewing direction of the monitor shall roughly be the same direction as the one for the main mirror.~~

Japan Comment: To be removed not needed.

16.2.4. Vehicles may be equipped with additional devices for indirect vision.

16.2.5. The provisions of this Regulation do not apply to the surveillance **Rear-View Camera** -recording devices defined in paragraph 2.3. of this Regulation. Exterior surveillance cameras either shall be mounted at least 2 m above the ground when the vehicle is under a load corresponding to its maximum technical permissible mass, or, if their lower edge is less than 2 m from the ground, shall not project more than 50 mm beyond the overall width of the

vehicle measured without this device and have a radii of curvature of not less than 2.5 mm.

OICA Comment: what is a surveillance camera-monitor-recording devices?

- 16.3 Notwithstanding the provisions above, any other design concept shall be demonstrated to the satisfaction of the Technical Service within the safety concept that is provided in the provisions above.

17. Requirements for detection systems

17.1. System activation

The system shall be activated when the backing event starts. If proper functioning cannot be effected, either the system shall automatically shut off or the driver shall be able to deactivate the system manually.

There may be an on/off switch or push-button to override automatic (de)activation by the driver. In case the vehicle can detect coupling with a towing vehicles, the automatic off function shall be activated.

OICA Comment: the two last sentences are not clear enough. All signals shall be deactivated

How is the text to be understood? Interpreted as trailer recognition or vehicle towing detection when towing?

What do you mean with that?

Japan Comment: Yes. This part based on past discussions.

17.2. Driver interface and information presentation strategy

~~17.2.1. [The system shall have at least two kinds of information signal selected from audible, optical, and haptics.]~~

Japan Comment: As proposed in .2.1.15, haptic proposed to be removed.

17.2.1. The system shall have both audible and optical information.

17.2.2. Audible information

When an object is detected in the rear horizontal area as described in paragraph 2.1. of Annex 12., audible information in accordance with ISO 15006:2010 shall be given.

In presenting audible information, the distance may be identified at two or more levels. These zones may be indicated by changing the frequency of intermittent sound, and a faster intermittent sound or continuous sound shall be used as the distance becomes closer.

17.2.3. Duration of signalling

Signalling for an object shall last as long as the object is detected and shall end when the object is no longer detected or when the system is deactivated.

To reduce the driver's discomfort, the audible signal can be automatically suspended temporarily after a certain time set by the manufacturer has elapsed, provided that the system remains activated. If, while the audible signal is automatically suspended temporarily, the distance to the object becomes short, the audible signal shall be automatically resumed. If the distance to the object becomes long, the audible signal may remain suspended.

OICA Comment: If the obstacle is removed, the sound output is immediately suppressed, but the system remains active. When approaching, you will be alerted again acoustically. Would that be compliant to this article?

Japan Comment: Yes.

17.3. Dynamic performance of object detection

- 17.4.1. Detection latency
The detection latency as measured according to paragraph 2.2. of Annex 12. shall not exceed 0.6 s.

~~17.4.1. Detection latency
The detection latency as measured according to paragraph 2.2. of Annex 12. shall not exceed 0.6 s.~~

OICA Justification: what is the aim of adding a detection latency. Only the response time is necessary.

Japan Comment: Not agree to remove. Detection system compatibility with RVC is secured at 0.6s detection latency in the past discussion.

- 17.4.2 Response time
The signal meeting the requirements of Annex 12 of this Regulation shall be given to the driver within 2.0 seconds when the backing event starts.

OICA Comment: all vehicle categories shall be considered. May be challenging for long vehicles.

Japan Comment: Can be removed. Detection system don't warn until VRU is in the detection distance. Driver need not to aware until warning coming.

18. Modifications of the vehicle type and extension of approval

- 18.1. Every modification of the vehicle type shall be notified to the Type Approval Authority which approved the vehicle type. Type Approval Authority shall then either:
- (a) Decide, in consultation with the manufacturer, that a new type approval is to be granted; or
 - (b) Apply the procedure contained in paragraph 18.1.1. (Revision) and, if applicable, the procedure contained in paragraph 18.1.2. (Extension).
- 18.1.1. Revision
When particulars recorded in the information folder have changed and the Type Approval Authority considers that the modifications made are unlikely to have an appreciable adverse effect, and that in any case the vehicle still complies with the requirements, the modification shall be designated a "revision".
In such a case, the Type Approval Authority shall issue the revised pages of the information folder as necessary, marking each revised page to show clearly the nature of the modification and the date of re-issue. A consolidated, updated version of the information folder, accompanied by a detailed description of the modification, shall be deemed to meet this requirement.
- 18.1.2. Extension
The modification shall be designated an "extension" if, in addition to the change of the particulars recorded in the information folder,
- (a) Further inspections or tests are required; or
 - (b) Any information on the communication document (with the exception of its attachments) has changed; or
 - (c) Approval to a later series of amendments is requested after its entry into force.
- 18.2. Confirmation or refusal of approval, specifying the alterations, shall be communicated to the Parties to the Agreement which apply this Regulation by means of a form conforming to the model in Annex 4 to this Regulation. In

addition, the index to the information package, attached to the communication document, shall be amended accordingly to show the date of the most recent revision or extension.

- 18.3. The Type Approval Authority issuing the extension of approval shall assign a series number to each communication form drawn up for such an extension.

19. Conformity of production

- 19.1. The conformity of production procedure shall comply with those set out in the Agreement, Schedule 1, (E/ECE/324-E/ECE/TRANS/505/Rev.3).
- 19.2. Every vehicle approved under this Regulation shall be so manufactured as to conform to the type approved by meeting the requirements set out in paragraph 15., and where applicable paragraph 16. above.

20. Penalties for non-conformity of production

- 20.1. The approval granted in respect of a vehicle type pursuant to this Regulation may be withdrawn if the requirement laid down in paragraph 18.1. above is not complied with or if the vehicle fails to pass the checks prescribed in paragraph 18.2. above.
- 20.2. If a Party to the Agreement which applies this Regulation withdraws an approval it has previously granted, it shall forthwith so notify the other Contracting Parties applying this Regulation by means of a copy of the approval form bearing at the end, in large letters, the signed and dated annotation "APPROVAL WITHDRAWN".

21. Production definitively discontinued

If the holder of the approval completely ceases to manufacture a type of vehicle approved in accordance with this Regulation, he shall so inform the Type Approval Authority which granted the approval. Upon receiving the relevant communication, the Authority shall inform thereof the other Parties to the Agreement applying this Regulation by means of a copy of the approval form bearing at the end, in large letters, the signed and dated annotation "PRODUCTION DISCONTINUED".

22. Names and addresses of Technical Services responsible for conducting approval tests, and of Type Approval Authorities

The Parties to the Agreement applying this Regulation shall communicate to the United Nations Secretariat the names and addresses of the Technical Services responsible for conducting approval tests and of the Type Approval Authorities which grant approval and to which forms certifying approval or refusal or extension or withdrawal of approval, issued in other countries, are to be sent.

Annex 1

Information document for type approval of a device for reversing motion

The following information, if applicable, shall be supplied in triplicate and shall include a list of contents.

Any drawings shall be supplied in appropriate scale and in sufficient detail on size A4 paper or on a folder of A4 format.

Photographs, if any, shall show sufficient details.

1. Make (trade name of manufacturer):
2. Type and general commercial description(s):
3. Means of identification of the type, if indicated on the device:
4. Category of vehicle for which the device is intended:
5. Name and address of manufacturer:
6. Location and method of affixing of the approval mark:
- 6.1. Other mean of identification link to the approval mark:
7. Address(es) of assembly plant(s):
8. Mirrors (state for each mirror):
- 8.1. Variant
- 8.2. Drawing(s) for the identification of the mirror:
- 8.3. Details of the method of attachment:
9. Devices for indirect vision other than mirrors:
- 9.1. Type and characteristics (such as a complete description of the device):
- 9.1.1. In the case of **Rear-View Camera**, ~~the class~~, the detection distance [mm], contrast, luminance range, glare correction, display performance (black and white/colour) image repetition frequency, luminance reach of the monitor:
- 9.1.2. In the case of detection system ~~of Classes VIII~~, **the class**, field of view, latency and rear horizontal area and detection rate:
- 9.2. Sufficiently detailed drawings to identify the complete device including installation instructions; the position for the type-approval mark has to be indicated on the drawings:

Annex 2

Information document for type approval of a vehicle with respect to the installation of devices for reversing motion

The following information, if applicable, shall be supplied in triplicate and include a list of contents.

Any drawings shall be supplied in appropriate scale and in sufficient detail on size A4 paper or on a folder of A4 format.

Photographs, if any, shall show sufficient details.

General

1. Make (trade name of manufacturer):
2. Type and general commercial description(s):
3. Means of identification of type, if marked on the vehicle:
4. Location of that marking:
5. Category of vehicle:
6. Name and address of manufacturer:
7. Address(es) of assembly plant(s):

General construction characteristics of the vehicle

8. Photograph(s) and/or drawing(s) of a representative vehicle:
9. ~~Driving cab (forward control or bonneted):³~~

OICA Justification: to be in line with comment in 12.5

Japan Comment: Agree to remove.

10. Driving position: left/right¹
- 10.1. The vehicle is equipped to be driven in right-hand/left hand traffic¹
11. Range of vehicle dimensions (overall):
- 11.1 For chassis without bodywork
- 11.1.1. Width:⁴
- 11.1.1.1. Maximum permissible width:
- 11.1.1.2. Minimum permissible width:
- 11.2. For chassis with bodywork:

³ Strike out where not applicable

⁴ "Overall width" of a vehicle means a dimension which is measured according to ISO standard 612-1978, term No. 6.2. In the case of vehicles of category other than M₁, in addition to the provisions of that standard, when measuring the vehicle width the following devices shall not be taken into account:

- (a) Customs sealing devices and their protection;
- (b) Devices for securing the tarpaulin and their protection;
- (c) Tyre failure tell-tale devices;
- (d) Protruding flexible parts of a spray-suppression system;
- (e) Lighting equipment;
- (f) For buses, access ramps in running order, lifting platforms and similar equipment in running order provided that they do not exceed 10 mm from the side of the vehicle and the corners of the ramps facing forwards or rearwards are rounded to a radius of not less than 5 mm; the edges shall be rounded to a radius of not less than 2.5 mm;
- (g) Devices for indirect vision;
- (h) Tyre-pressure indicators;
- (i) Retractable steps;
- (j) The deflected part of the tyre walls immediately above the point of contact with the ground.

11.2.1.	Width ²
12.	Bodywork
12.1.	Devices for indirect vision
12.1.1.	Mirrors
12.1.1.1.	Drawing(s) showing the position of the mirror relative to the vehicle structure:
12.1.1.2.	Details of the method of attachment including that part of the vehicle structure to which it is attached:
12.1.1.3.	Optional equipment which may affect the rearward field of vision:
12.1.1.4.	A brief description of the electronic components (if any) of the adjustment device:
12.1.2.	Devices for indirect vision other than mirrors:
12.1.2.1.	Sufficiently detailed drawings with the installation instructions:
12.1.2.2.	In the case of Rear-View Camera :
12.1.2.2.1.	Drawing(s)/photograph(s) showing the position of the camera(s) relative to the vehicle structure:
12.1.2.2.2.	Drawing(s)/photograph(s) showing the arrangement of the monitor(s) including surrounding interior parts:
12.1.2.2.3.	Drawing(s)/photograph(s) showing the drivers view onto the monitor(s):
12.1.2.2.4.	Drawing(s)/photograph(s) showing the setup and monitor image of the required field of view:
12.1.2.2.5.	Details of the method of attachment of the Rear-View Camera including that part of the vehicle structure to which it is attached:
12.1.2.2.6.	Optional equipment which may affect the rearward field of vision:
12.1.2.2.7.	A brief description of the electronic components (if any) of the adjustment device:
12.1.2.2.8.	A technical specification and operator's manual of the Rear-View Camera according to ISO 16505:2015 :

Annex 3

Communication

(Maximum format: A4 (210 x 297 mm))

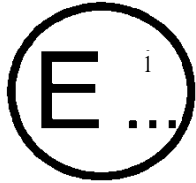

issued by:

Name of administration:

.....

- Concerning:⁶
- Approval granted
 - Approval extended
 - Approval refused
 - Approval withdrawn
 - Production definitively discontinued

of a type of device for indirect vision pursuant to UN Regulation No. XXX

Approval No. Extension No.

1. Trade name or mark of device:
 2. Manufacturer's name for the type of device:
 3. Manufacturer's name and address:
 4. If applicable, name and address of manufacturer's representative:
 5. Submitted for approval on:
 6. Technical Service responsible for conducting approval tests:
 7. Date of report issued by that Service
 8. Number of report issued by that Service
 9. Brief description
- Identification of the device: mirror, **Rear-View Camera**, other device²
- Device for close-proximity rear view²
- Symbol $\frac{\Delta}{2m}$ as defined in paragraph 6.3.1.1. of this Regulation: yes/no²
10. Position of the approval mark:
 11. Reason(s) for extension (if applicable):
 12. Approval granted/refused/extended/withdrawn:²
 13. Place:.....
 14. Date:.....
 15. Signature:
 16. The list of documents deposited with the Type Approval Authority which has granted approval is annexed to this communication and may be obtained on request.

¹ Distinguishing number of the country which has granted/extended/refused/withdrawn approval (see approval provisions in the Regulations).

⁶ Strike out what does not apply.

Annex 4

Communication

(Maximum format: A4 (210 x 297 mm))



issued by :

Name of administration:

.....

Concerning:⁸ Approval granted
 Approval extended
 Approval refused
 Approval withdrawn
 Production definitively discontinued

of a type of vehicle with regard to the mounting of devices for indirect vision pursuant to UN Regulation No. 46

Approval number: Extension No.:

1. Make (trade name of manufacturer):
2. Type and general commercial description(s)
3. Means of identification of type, if marked on the vehicle:.....
- 3.1. Location of that marking:.....
4. Category of vehicle: (M₁, M₂, M₃, N₁, N₂ ≤ 7.5 t, N₂ > 7.5 t, N₃)²
5. Name and address of manufacturer:.....
6. Address(es) of the production plant(s)
7. Additional information: (where applicable). See appendix
8. Technical Service responsible for carrying out the tests:
9. Date of test report:
10. Number of test report:
11. Remarks: (if any). See appendix
12. Place:.....
13. Date:.....
14. Signature:
15. The index to the information package lodged with the Type Approval Authority, which may be obtained on request is attached.

⁷ Distinguishing number of the country which has granted/extended/refused/withdrawn approval (see approval provisions in the Regulation).

⁸ Strike out what does not apply.

Annex 4 – Appendix

Appendix to type approval communication form No. concerning the type approval of a vehicle with regard to the mounting of devices for reversing motion under UN Regulation No. [XXX].

1. Trade name or mark of mirrors and supplementary devices for indirect vision and component type-approval number:
2. Close-proximity rear-view mirrors and devices for reversing motion⁹
3. Extension of type approval of the vehicle to cover the following device for indirect vision.....
4. Data for identification of the R point of the driver's seating position:
5. Maximum and minimum bodywork width in respect of which the mirror and the devices for indirect vision has been granted type-approval
6. The following documents, bearing the type approval number shown above, are annexed to this certificate:.....
 - (a) Drawings showing the mounting of the devices for indirect vision
 - (b) Drawings and plans showing the mounting position and characteristics of the part of the structure where the devices for indirect vision are mounted.
7. Remarks: (e.g. valid for right hand/left hand traffic¹)

⁹ Strike out what does not apply.

Annex 5

Arrangement of approval mark of a device for indirect vision

(See paragraph 5.4. of the Regulation)

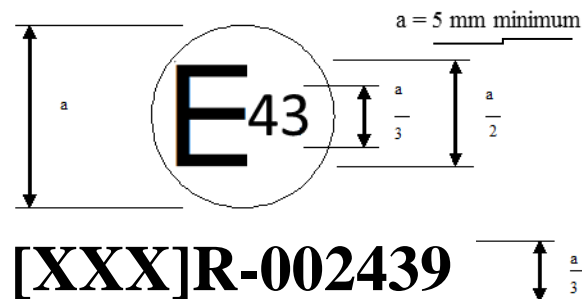

The above approval mark affixed to a device for indirect vision indicates that the device is a main Close-proximity rear-view device, which has been approved in Japan (E 43) pursuant to UN Regulation No. [XXX] and under approval number 002439. The first two digits of the approval number indicate that the approval was granted in accordance with the requirements of UN Regulation No. [XXX] in its original form.

Note: The approval number and the additional symbol shall be placed close to the circle and either above or below the "E" or to the left or right of that letter. The digits of the approval number shall be on the same side of the "E" and point in the same direction. The additional symbol shall be directly opposite the approval number. The use of Roman numerals as approval numbers shall be avoided so as to prevent any confusion with other symbols.

Annex 6

Test method for determining reflectivity

1. Definitions
 - 1.1. CIE standard illuminate A:¹ Colorimetric illuminate, respecting the full radiator at $T_{68} = 2,855.6$ K.
 - 1.1.2. CIE standard source A¹: Gas-filled tungsten filament lamp operating at a correlated colour temperature of $T_{68} = 2,855.6$ K.
 - 1.1.3. CIE 1931 standard colorimetric observer¹: Receptor of radiation whose colorimetric characteristics correspond to the spectral tristimulus values (see $\bar{x}(\lambda)$, $\bar{y}(\lambda)$, $\bar{z}(\lambda)$ table).
 - 1.1.4. CIE spectral tristimulus values¹: Tristimulus values of the spectral components of an equi energy spectrum in the CIE (XYZ) system.
 - 1.1.5. Photopic vision:¹ Vision by the normal eye when it is adapted to levels of luminance of at least several cd/m^2 .
 2. Apparatus
 - 2.1. General

The apparatus shall consist of a light source, a holder for the test sample, a receiver unit with a photodetector and an indicating meter (see Figure 1), and means of eliminating the effects of extraneous light.

The receiver may incorporate a light-integrating sphere to facilitate measuring the reflectance of non-flat (convex) mirrors (see Figure 2).
 - 2.2. Spectral characteristics of light source and receiver

The light source shall consist of a CIE standard source A and associated optics to provide a near-collimated light beam. A voltage stabiliser is recommended in order to maintain a fixed lamp voltage during instrument operation.

The receiver shall have a photodetector with a spectral response proportional to the photopic luminosity function of the CIE (1931) standard colorimetric observer (see table). Any other combination of illuminate-filter-receptor giving the overall equivalent of CIE standard illuminate A and photopic vision may be used. When an integrating sphere is used in the receiver, the interior surface of the sphere shall be coated with a matt (diffusive) spectrally non-selective white coating.
 - 2.3. Geometrical conditions

The angle of the incident beam (Θ) should preferably be 0.44 ± 0.09 rad ($25 \pm 5^\circ$) from the perpendicular to the test surface and shall not exceed the upper limit of the tolerance (i.e. 0.53 rad or 30°). The axis of the receptor shall make an angle (Θ) with this perpendicular equal to that of the incident beam (see Figure 1). The incident beam upon arrival at the test surface shall have a diameter of not less than 13 mm (0.5 inch). The reflected beam shall not be wider than the sensitive area of the photodetector, shall not cover less than 50 per cent of such area, and as nearly as possible shall cover the same area segment as used during instrument calibration.

When an integrating sphere is used in the receiver section, the sphere shall have a minimum diameter of 127 mm (5 inch). The sample and incident beam

¹ Definitions taken from CIE publication 50 (45), International Electrotechnical Vocabulary, Group 45, Lighting

apertures in the sphere wall shall be of such a size as to admit the entire incident and reflected light beams. The photodetector shall be so located as not to receive direct light from either the incident or the reflected beam.

2.4. Electrical characteristics of the photodetector-indicator unit

The photodetector output as read on the indicating meter shall be a linear function of the light intensity of the photosensitive area. Means (electrical and/or optical) shall be provided to facilitate zeroing and calibration adjustments. Such means shall not affect the linearity or the spectral characteristics of the instrument. The accuracy of the receptor indicator unit shall be within ± 2 per cent of full scale, or ± 10 per cent of the magnitude of the reading, whichever is the smaller.

2.5. Sample holder

The mechanism shall be capable of locating the test sample so that the axes of the source arm and receptor intersect at the reflecting surface. The reflecting surface may lie within or at either face of the mirror sample, depending on whether it is a first surface, second surface or prismatic "flip" type mirror.

3. Procedure

3.1. Direct calibration method

In the direct calibration method, air is used as the reference standard. This method is applicable for those instruments, which are so constructed as to permit calibration at the 100 per cent point by swinging the receiver to a position directly on the axis of the light source (see Figure 1).

It may be desired in some cases (such as when measuring low-reflectivity surfaces) to use an intermediate calibration point (between 0 and 100 per cent on the scale) with this method. In these cases, a neutral density filter of known transmittance shall be inserted in the optical path, and the calibration control shall then be adjusted until the meter reads the percentage transmission of the neutral density filter. This filter shall be removed before reflectivity measurements are performed.

3.2. Indirect calibration method

The indirect calibration method is applicable in the case of instruments with fixed source and receiver geometry. A properly calibrated and maintained reflectance standard is required. This reference standard should preferably be a flat mirror with a reflectance value as near as possible to that of the test samples.

3.3. Flat mirror measurement

The reflectance of flat mirror samples can be measured on instruments employing either the direct or the indirect calibration method. The reflectance value is read directly from the indicating meter.

3.4. Non-flat (convex) mirror measurement

Measurement of the reflectance of non-flat (convex) mirrors requires the use of instruments which incorporate an integrating sphere in the receiver unit (see Figure 2). If the instrument-indicating meter indicates n_e divisions with a standard mirror of E per cent reflectance, then, with a mirror of unknown reflectance, n_x divisions will correspond to a reflectance of X per cent, in accordance with the formula:

$$X = E \frac{n_x}{n_e}$$

Figure 1
Generalised reflectometer showing experimental set-ups for the two calibration methods

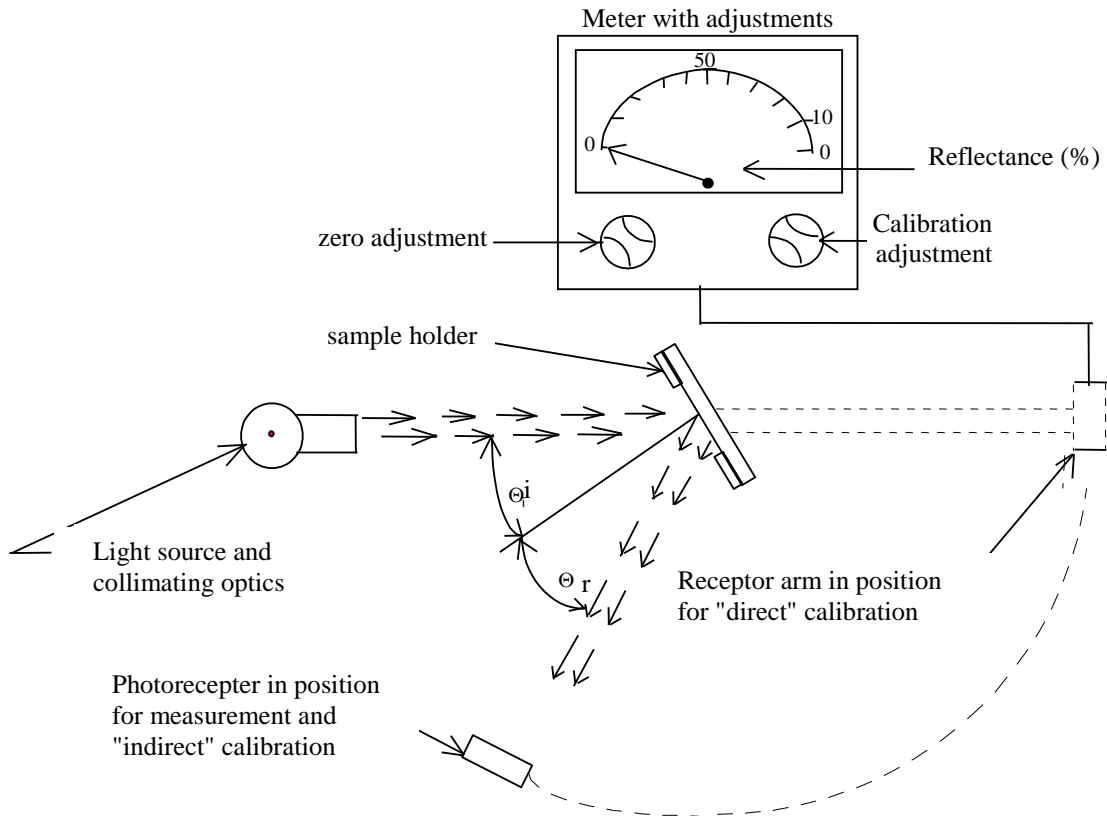
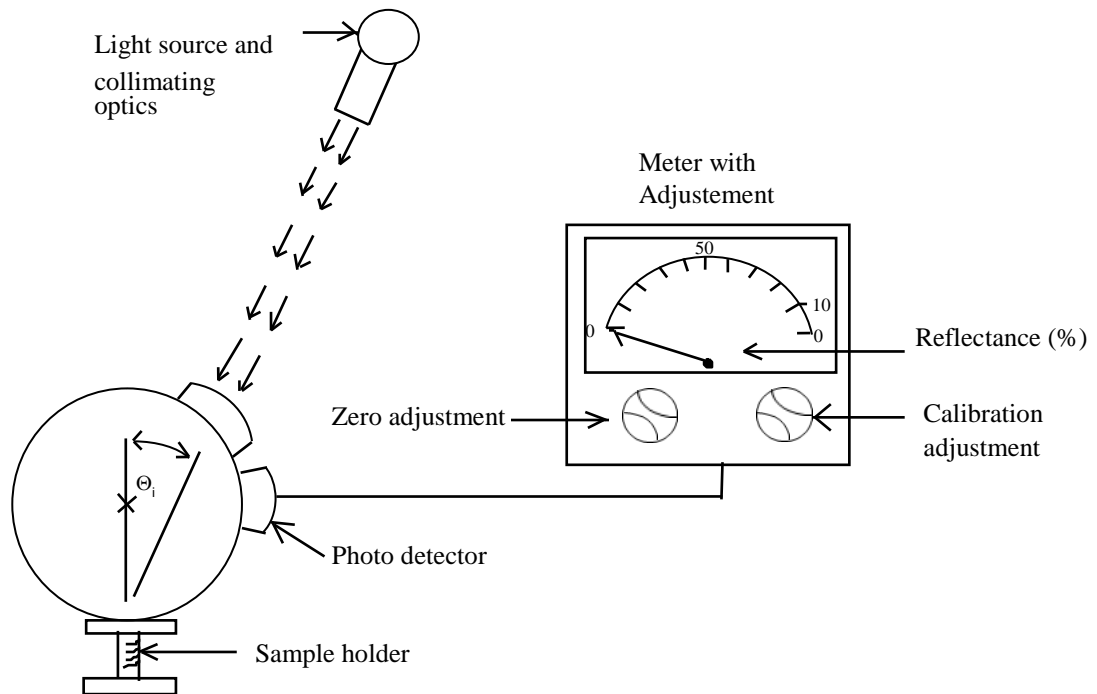

Figure 2
Generalised reflectometer, incorporating an integrating sphere in the receiver



4. Spectral tristimulus values for the CIE 1931 standard colorimetric observer²
This table is taken from CIE publication 50 (45) (1970)

λ nm	$\bar{x}(\lambda)$	$\bar{y}(\lambda)$	$\bar{z}(\lambda)$
380	0.001 4	0.000 0	0.006 5
390	0.004 2	0.000 1	0.020 1
400	0.014 3	0.000 4	0.067 9
410	0.043 5	0.001 2	0.207 4
420	0.134 4	0.004 0	0.645 6
430	0.283 9	0.011 6	1.385 6
440	0.348 3	0.023 0	1.747 1
450	0.336 2	0.038 0	1.772 1
460	0.290 8	0.060 0	1.669 2
470	0.195 4	0.091 0	1.287 6
480	0.095 6	0.139 0	0.813 0
490	0.032 0	0.208 0	0.465 2
500	0.004 9	0.323 0	0.272 0
510	0.009 3	0.503 0	0.158 2
520	0.063 3	0.710 0	0.078 2
530	0.165 5	0.862 0	0.042 2
540	0.290 4	0.954 0	0.020 3
550	0.433 4	0.995 0	0.008 7
560	0.594 5	0.995 0	0.003 9
570	0.762 1	0.952 0	0.002 1
580	0,916 3	0.870 0	0.001 7
590	1.026 3	0.757 0	0.001 1
600	1.062 2	0.631 0	0.000 8
610	1.002 6	0.503 0	0.000 3
620	0.854,4	0.381 0	0.000 2
630	0.642 4	0.265 0	0.000 0
640	0.447 9	0.175 0	0.000 0
650	0.283 5	0,107 0	0.000 0
660	0.164 9	0.061 0	0.000 0
670	0.087 4	0,032 0	0.000 0
680	0.046 8	0.017 0	0.000 0
690	0.22 7	0,008 2	0.000 0
700	0.011 4	0.004 1	0.000 0
710	0.005 8	0.002 1	0.000 0
720	0.02 9	0.001 0	0.000 0
730	0.001 4	0.000 5	0.000 0
740	0.000 7	0.000 2 (*)	0.000 0
750	0.000 3	0.000 1	0.000 0
760	0.000 2	0.000 1	0.000 0
770	0.000 1	0.000 0	0.000 0
780	0.000 0	0.000 0	0.000 0

(*) Changed in 1966 (from 3 to 2)

² Abridged table. The values of $\bar{y}(\lambda) = V(\lambda)$ are rounded off to four decimal places

Explanatory figure
Example of device for measuring the reflection factor of spherical mirrors

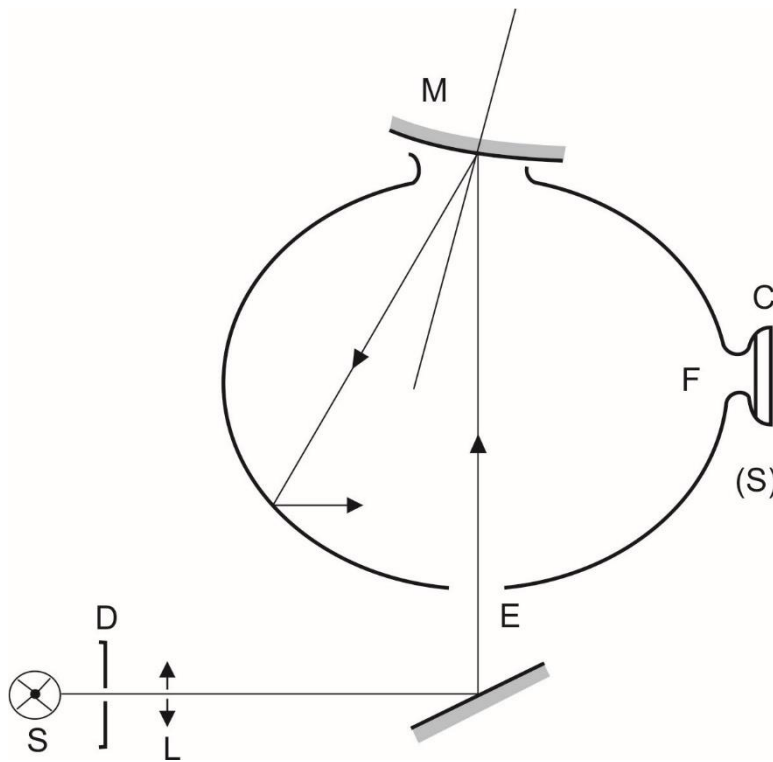

- C = Receiver
- D = Diaphragm
- E = Window of entry
- F = Window of measurement
- L = Lens
- M = Object window
- S = Light source
- (S) = Integrating sphere

Annex 7

Procedure for determining the radius of curvature "r" of the reflecting surface of a mirror

1. Measurement
 - 1.1. Equipment

A "spherometer" similar to the one described in Figure 1 of this annex having the indicated distances between the tracing pin of the dial gauge and the fixed legs of the bar is used.
 - 1.2. Measuring points
 - 1.2.1. The principal radii of curvature shall be measured at three points situated as close as possible to positions at one-third, one-half and two-thirds of the distance along the arc of the reflecting surface passing through the centre of this surface and parallel to segment b, or of the arc passing through the centre of the reflecting surface which is perpendicular to it if this arc is the longer.
 - 1.2.2. Where, owing to the size of the reflecting surface, it is impossible to obtain measurements in the directions defined in paragraph 2.1.1.5. of this Regulation, the Technical Services responsible for the tests may take measurements at the said point in two perpendicular directions as close as possible to those prescribed above.
2. Calculation of the radius of curvature "r"

"r" expressed in mm is calculated from the formula:

$$r = \frac{r_p1 + r_p2 + r_p3}{3}$$

Where:

- r_p1 = the radius of curvature at the first measuring point,
 r_p2 = the radius of curvature at the second measuring point,
 r_p3 = the radius of curvature at the third measuring point.

Figure 1
Spherometer

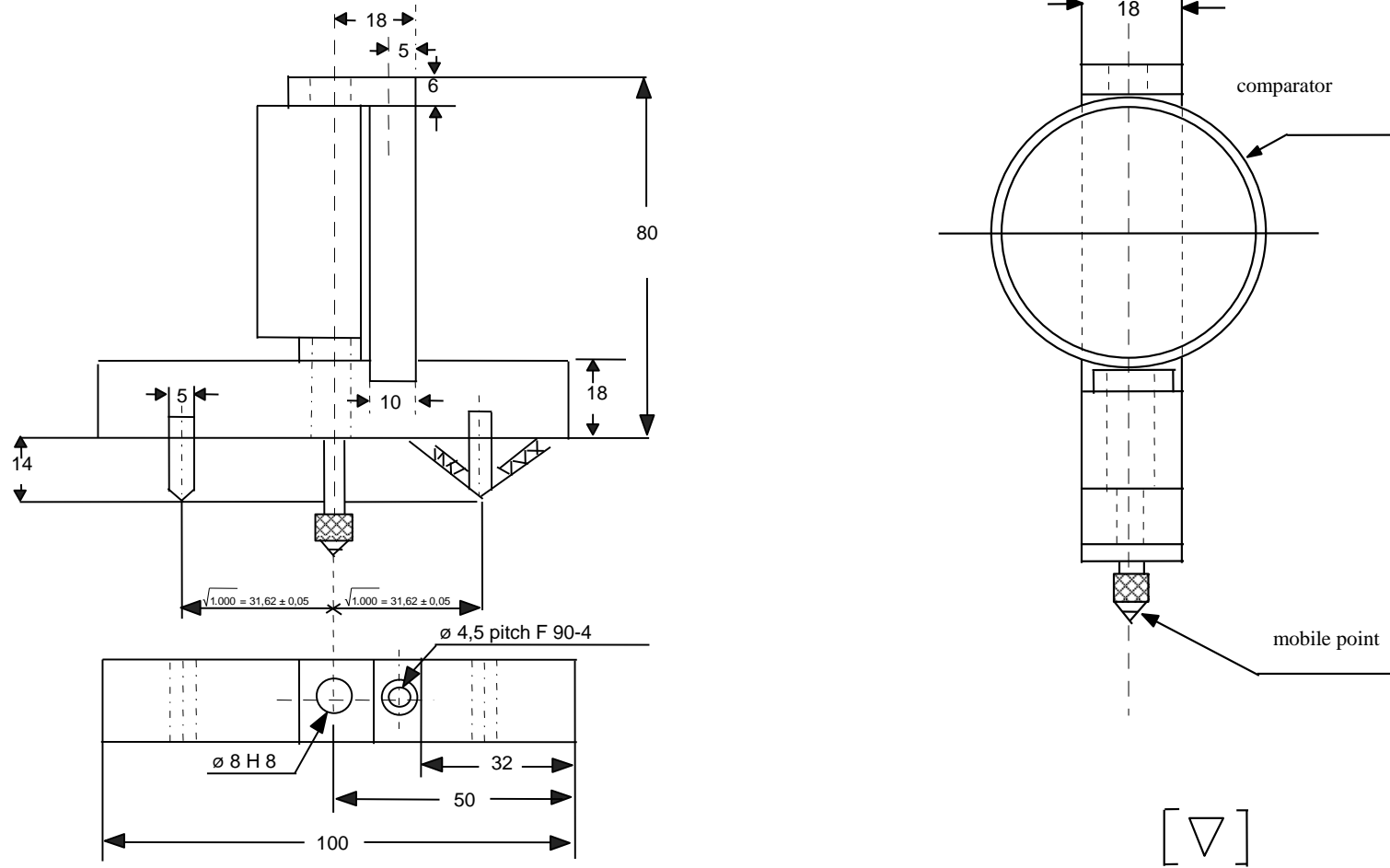

(all dimensions in millimetres)

Annex 8

Procedure for determining the "H" point and the actual torso angle for seating positions in motor vehicles¹²

Appendix 1 - Description of the three dimensional "H" point machine (3-D H machine)¹

Appendix 2 - Three-dimensional reference system¹

Appendix 3 - Reference data concerning seating positions¹

¹² The procedure is described in Annex 1 to the Consolidated Resolution on the Construction of Vehicles (R.E.3) (document ECE/TRANS/WP.29/78/Rev.6).
www.unece.org/trans/main/wp29/wp29wgs/wp29gen/wp29resolutions.html

Annex 9

~~Determination of the displayed object size for CMS of Close proximity rear-view~~

Japan Comment: To be removed due to monitor requirements was removed.

~~1. Camera monitor device for indirect vision~~

~~1.1. General~~

~~Determination of the displayed object size considers the possible appearance of smear. The impact on the monitors image and consequence is the occultation of the field of view and therefore of the object. The following differentiation is made:~~

~~1.2. Case A: Smear appears~~

~~1.2.1. Step 1: Under the condition described in paragraph 6.2.2.1.2. of this Regulation, measure the width (s) of the vertical bar displayed on the monitor e.g. with a measurement microscope.~~

~~1.2.2. Step 2: Place the object at a defined distance from the camera. Measure the width of the object displayed on the monitor (b) in a situation without real sun light condition e.g. with a measurement microscope.~~

~~1.2.3. Step 3: Calculate the residual object width (α) according to the following equation:~~

$$\alpha ['] = 60 \times 2 \times \arctan \frac{b-s}{2 \times r}$$

~~Where:~~

~~α : residual width of the object displayed on the monitor (with smear) [minutes of arc]~~

~~b: width of the object displayed on the monitor (without smear) [mm]~~

~~s: width of the smear [mm]~~

~~r: viewing distance [mm]~~

~~1.3. Case B: Smear does not appear~~

~~1.3.1. Step 1: Place the object at a defined distance from the camera. Measure the width of the object displayed on the monitor (b) in a situation without real sun light condition e.g. with a measurement microscope.~~

~~1.3.2. Step 2: Calculate the object width (α) according to the following equation:~~

$$\alpha ['] = 60 \times 2 \times \arctan \frac{b}{2 \times r}$$

~~Where:~~

~~α : width of the object displayed on the monitor (without smear) [minutes of arc]~~

~~b: width of the object displayed on the monitor (without smear) [mm]~~

~~r: viewing distance [mm]~~

~~1.4. Data supplied by the instructions for use~~

~~In the case of Classes VIII camera monitor devices the instructions for use shall include a table that shows the minimum and maximum mounting height of the camera above ground under consideration of different viewing distances. The camera shall be mounted within the applicable height range. The viewing~~

distances shall be selected from the intended context of use. The following table shows an example.

Viewing distance	0.5 m	1.0 m	1.5 m	2.0 m	2.5 m
Minimum mounting height	para. 1.4.1.	para. 1.4.1.	para. 1.4.1.	para. 1.4.1.	para. 1.4.1.
Maximum mounting height	para. 1.4.2.	para. 1.4.2.	para. 1.4.2.	para. 1.4.2.	para. 1.4.2.

~~1.4.1. The value of the minimum mounting height is the same for all viewing distances as it is independent of the viewing distance. It is determined by the dimensions of the field of vision and the field of view of the camera. Use the following working steps for determination of the minimum mounting height.~~

~~1.4.1.1. Step 1: Draw the intended field of vision on ground.~~

~~1.4.1.2. Step 2: Place the camera above the field of vision in such a way that the camera is viewing the field of vision. The lateral position shall be in accordance with the intended mounting position at the vehicle.~~

~~1.4.1.3. Step 3: Change the height of the camera above ground in such a way, that the field of vision displayed on the monitor covers an area at least as large as the field of vision. Furthermore, the field of vision display shall encompass the entire monitor screen.~~

~~1.4.1.4. Step 4: Measure the height between camera and ground which is the minimum mounting height. Report the result value.~~

~~1.4.2. The value of the maximum mounting height is different for different viewing distances as the displayed object size varies with the mounting height. Use the following working steps for determination of the maximum mounting height:~~

~~1.4.2.1. Step 1: Determine the minimum width b_{\min} of the critical object displayed on the monitor for each viewing distance:~~

$$b_{\min} = 2 \times r \times \tan \frac{8'}{2 \times 60}$$

~~Where:~~

~~r: viewing distance [mm]~~

~~b_{\min} : minimum width of the critical object displayed on the monitor [mm]~~

~~1.4.2.2. Step 2: Place the critical object inside the drawn intended field of vision in a position at which the distance between the critical object and the camera is largest. The illumination conditions shall be in such a way that the critical object is clearly visible on the monitor.~~

~~1.4.2.3. Step 3: Select the first value of the possible viewing distances.~~

~~1.4.2.4. Step 4: Change the height of the camera above ground in such a way, that the residual width B of the object displayed on the monitor is equal to the minimum width allocated to that viewing distance.~~

$$B = b_{\min}$$

~~Where:~~

~~B: residual width of the object displayed on the monitor (which is "b" in cases without smear and "b-s" in cases with smear) in mm (see paragraph 1.1. General)~~

- ~~1.4.2.5. Step 5: Measure the height between camera and ground which is the maximum mounting height allocated to that viewing distance. Report the result value.~~
- ~~1.4.2.6. Step 6: Repeat the aforementioned steps 4 and 5 for the other viewing distances.~~

Annex 11

Test conditions for Close-proximity rear-view field of vision

1. Field of vision

The requirements of field of vision defined in **paragraph 15.2.** of this Regulation can be tested under the conditions described in this Annex.

OICA Justification: to be in line with the updated section 15 (that make the requirements clearer).

Japan Comment: Agreed.

1.1. Test objects

Each test object shall be a right circular cylinder that is 0.8 m high and 0.3 m in external diameter. Each test object shall be marked as follows.

(a) The test object shall have a painted patch measuring 0.15 m x 0.15 m that can be moved from the bottom to the top of the side of the cylinder.

(b) The painted patch shall be of a colour that contrasts with both the rest of the cylinder and the test surface.

Figure A
Test object

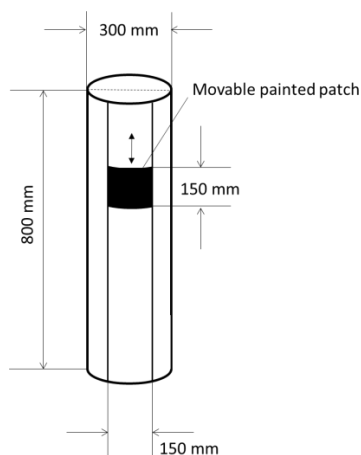

1.2. Test object locations and orientations

Place the test objects at the locations specified in (a) to (h) and illustrated in Figure B. Measure the distances shown in Figure B from a test object to another test object or other object from the cylindrical centre (axis) of the test object as viewed from above. Each test object shall be oriented so that its axis is vertical.

(a) Place test objects A, B, and C so that their centres are in a transverse vertical plane that is 0.3 m to the rear of a transverse vertical plane tangential to the rearmost surface of the rear bumper.

(b) Place test object B so that its centre is in a longitudinal vertical plane passing through the vehicle's longitudinal centreline.

(c) Place test objects D, E, and F so that their centres are in a transverse vertical plane that is 1.5 m to the rear of a transverse vertical plane tangential to the rearmost surface of the rear bumper.

(d) Place test object E so that its centre is in a longitudinal vertical plane passing through the vehicle's longitudinal centreline.

(e) Place test objects G, H, and I so that their centres are in a transverse vertical plane that is 3.5 m to the rear of a transverse vertical plane tangential to the

rearmost surface of the rear bumper.

(f) Place test object H so that its centre is in a longitudinal vertical plane passing through the vehicle's longitudinal centreline.

(g) Place test objects A, D, and G so that their outermosts are in a longitudinal vertical plane tangential to the left-side outermost surface of the vehicle.

(h) Place test objects C, F, and I so that their outermosts are in a longitudinal vertical plane tangential to the right-side outermost surface of the vehicle.

Test object locations can be added between A to I by the Technical Service.

Figure B
Test object locations

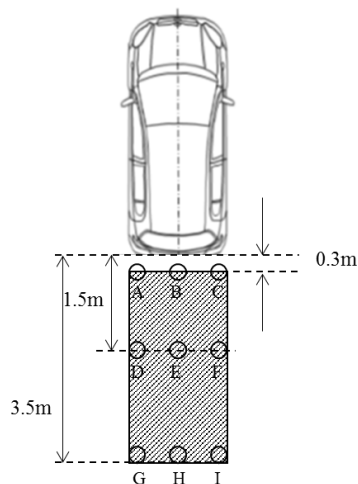

1.3. Requirements

(a) for the test objects in the first row (Test objects A, B, and C):

A 0.15 m x 0.15 m area or the top of the test object shall be visible at at least one position on each test object.

(b) for the test objects in the second row (Test objects D, E, and F) and the third row (Test objects G, H, and I):

The whole height of the test object shall be seen.

1.4. Test procedure

The visibility of each pole shall be tested one by one.

Annex 12

Test Methods for Detection Systems

1. Detection latency test method
 - 1.1. General test conditions

The test object shall be as per paragraph 7.1. of ISO 17386:2010. During testing, the wind speed shall not exceed 1 m/s. The temperature shall be $20 \pm 5^\circ\text{C}$ and the humidity shall be 60 ± 25 percent. There shall be no rain or snow. The test shall be performed on a flat, dry asphalt or concrete surface. The test shall not be affected by the reflection of sound waves or electromagnetic waves from any walls, auxiliary testing equipment or any other objects in the environment.
 - 1.2. Test conditions

The testing environment and test object shall be as per paragraph 3. of this annex. One test object shall be used. The distance from the rear edge to the test object and the position of the test object are selected by the manufacturer to ensure the detection of the test object. The test object shall be located in the detectable grids within the rear horizontal area in paragraph 5. of this annex. The test vehicle in the initial state shall be with the detection system in the activated state, which is declared [by the manufacturer OR in the owner's manual] and shall be in the parking condition. Here, the parking condition means that the P (park) position is selected in the case of vehicles equipped with automatic transmissions, whereas it means the neutral gear being selected and the parking brake being engaged in the case of vehicles equipped with manual transmissions.
 - 1.3. Test procedures
 - (a) With the vehicle in the initial state, locate the test object behind the vehicle and select the reverse gear.
 - (b) Measure the elapsed time (detection latency) from the moment at which the reverse gear is selected as specified by the manufacturer of the vehicle to the moment at which the audible warning starts.
2. Rear horizontal area detection test method

Audible warning systems shall fulfil the test as specified in paragraph 2.1. in this Annex. However, if audible warning systems fulfil the test as specified in paragraph 2.2. in this Annex, the test as specified in paragraph 2.1. in this Annex shall be considered to be satisfied.

 - 2.1. Test method for detection
 - 2.1.1. Monitoring area

The maximum detection distance in paragraphs 5.4.2. and 5.4.3. of ISO 17386:2010 shall be 1.0 m (Class R2). The width of the rectangle, w_r , is equal to the vehicle width, measured along the rear axle. The dimensions shall be rounded up to the nearest 0,1 m. The figure below gives examples of different w_r . (Figure 1 and 2).

Figure 1

In the case of odd-numbered poles in the vehicle lateral direction (e.g. $w_r=1.67\text{m}$)

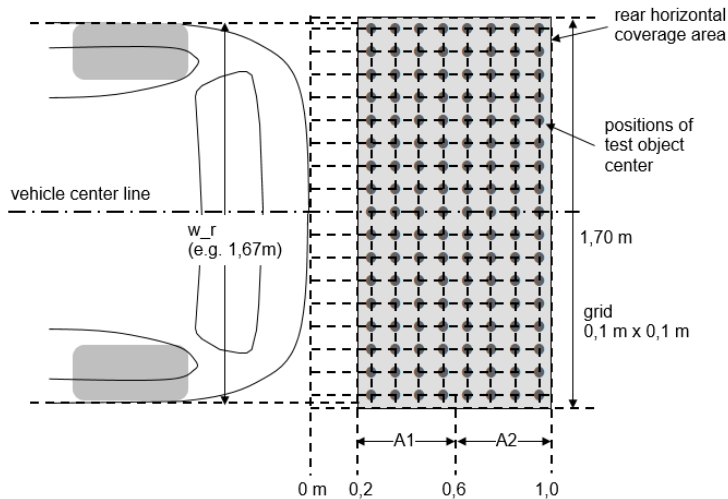
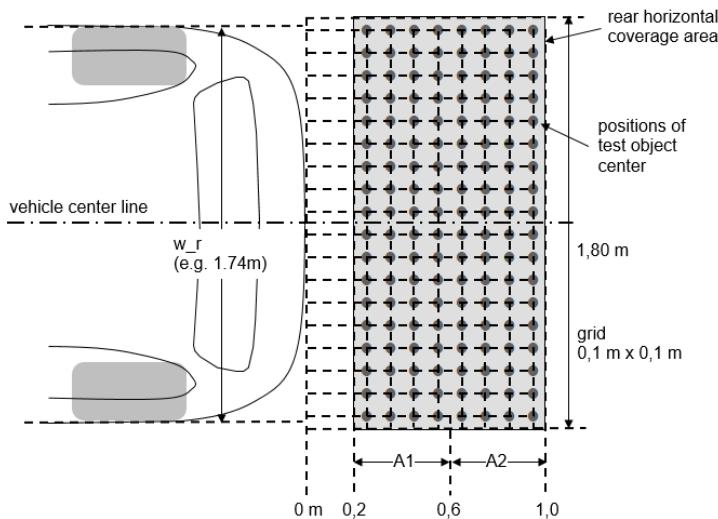

Figure 2

In the case of even-numbered poles in the vehicle lateral direction (e.g. $w_r=1,74m$)



2.1.2. Minimum detection rate

The minimum detection rate required for the rear horizontal area shall be as follows:

- (a) 90 percent for A1 as defined in paragraph 5.4.3. of ISO 17386:2010;
- (b) 87 percent for the rear-2 range in A2 as defined in paragraph 5.4.3. of ISO 17386:2010.

There shall be no undetected hole larger than a square consisting of two-by-two grids.

Here, the rear horizontal area test procedures shall be as per paragraph 7.3. of ISO 17386:2010.

When the warning is provided for more than [five] seconds continuously, it is judged that the test object is detected. The detection test shall be performed [one] time for each test object. However, if necessary, according to the agreement of the Technical Service and manufacturer, it can be judged that the test object is detected in case warnings are provided in [four] out of [five] tests.

2.2. Alternative (simplified) test method

2.2.1. Monitoring area

The monitoring areas are the six points shown in Figure 3 or 4 below within the monitoring area of paragraph 2.1.1.

Figure 3

In the case of odd-numbered poles in the vehicle lateral direction (e.g. $w_r = 1.67$ m)

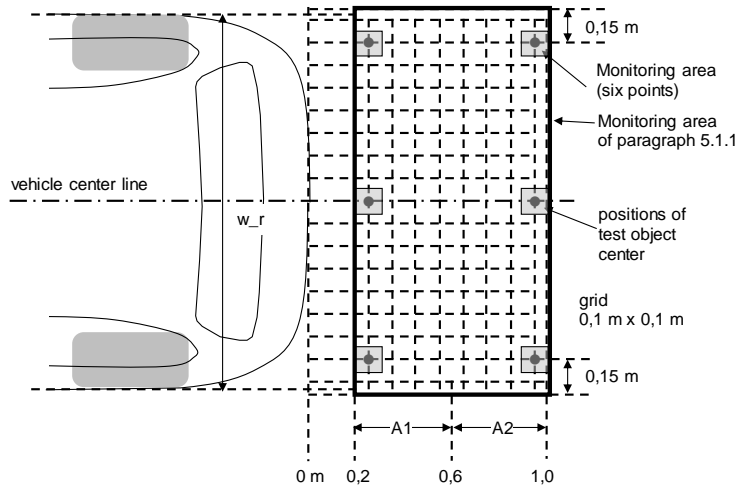
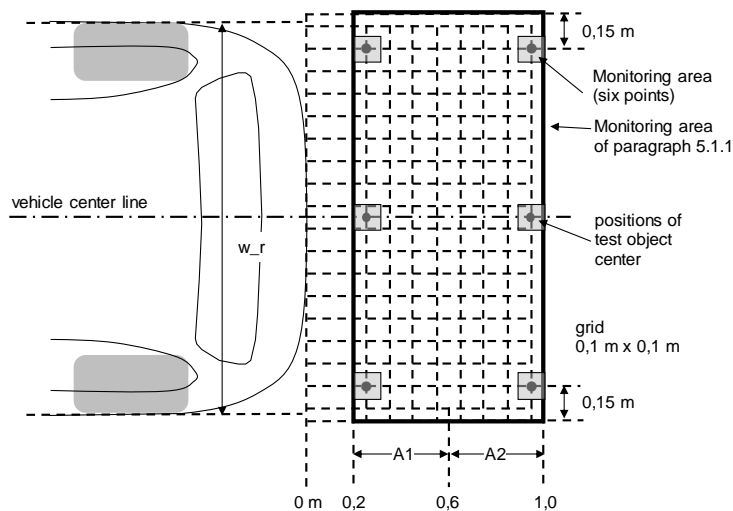

Figure 4

In the case of even-numbered poles in the vehicle lateral direction (e.g. $w_r = 1.74$ m)



2.2.2. Minimum detection rate

The minimum detection rate required for the area of six points shall be 100%.

When the warning is provided for more than [five] seconds continuously, it is judged that the test object is detected. The detection test shall be performed [one] time for each test object. However, if necessary, according to the agreement of the Technical Service and manufacturer, it can be judged that the test object is detected in case warnings are provided in [four] out of [five] tests.

3. Self-test capabilities and failure indication

As per paragraph 5.5. of ISO 17386:2010, the system shall provide self-test functions. It shall generate a warning signal, which is audible or visible or both, whenever a fault condition is detected.

II. Justification

This proposal is an update and rebuild of ECE/TRANS/WP.29/GRSG/2019/10 on the Close-proximity rear-view field of vision based on the discussions and conclusions of the VRU-Proxi Informal Working Group. Key updates are rebuild as new UN Regulation proposal and modifications of requirements. This proposal also reflects the ongoing discussions in the VRU-Proxi Informal Working Group.

Japan Comment: Annex 9, 10 is no longer exist. To be renumbered whole document along with latest corrections.