

Definition and testing of a Direct Vision Standard for HGVs – **Physical testing method- 27-11-19**

Loughborough University Design School: Design Ergonomics Research Group
Research Sponsored by Transport for London

Dr. Steve Summerskill

Dr. Russell Marshall, Dr Abby Paterson, Antony Eland, James Lenard, Steve Reed

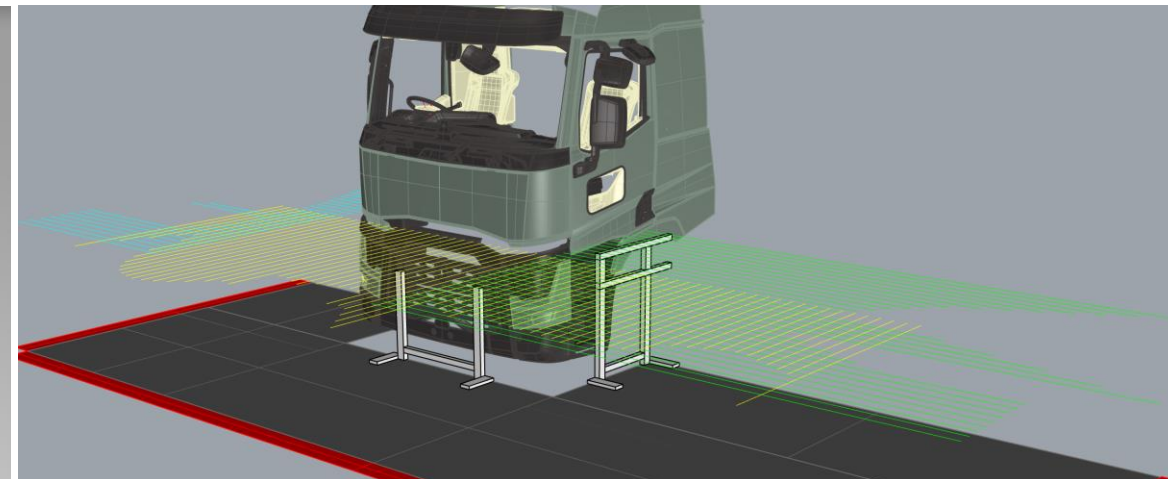
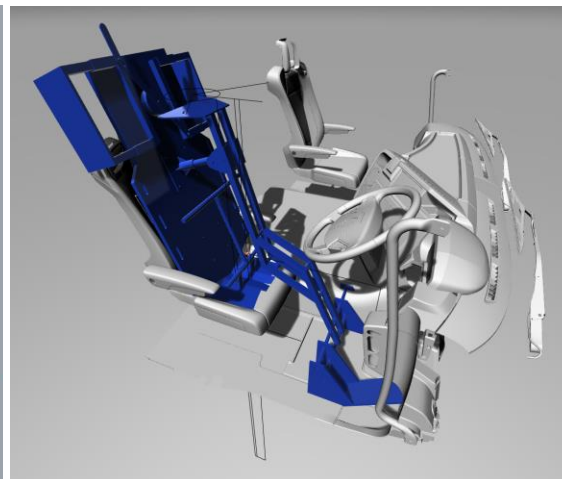
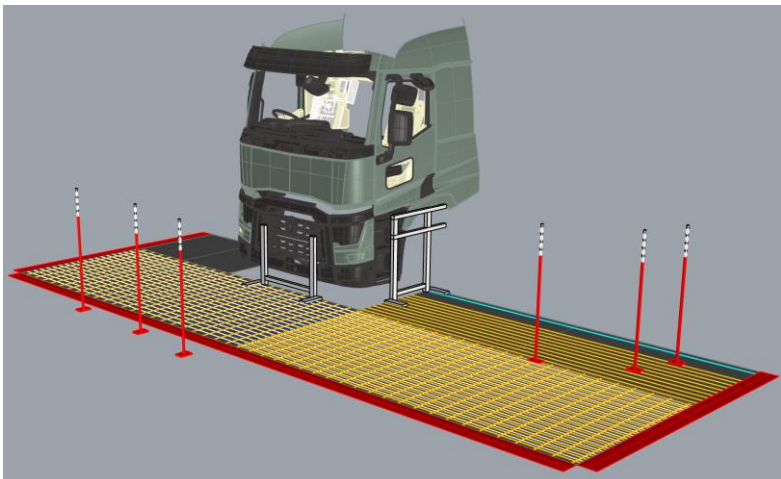

Contents

Short update on physical testing development

- Changes made since last meeting to the physical testing approach
- Results of the changes
- Next steps

What is the visual target that is used?

- We need a test that is analogous to the digital TfL DVS technique
- Therefore we have defined a test object that is the same height as the DVS VRU (5th percentile Italian female)
- We have also explored how much of this visual target should be visible during the testing
- The red section shown in the image is equivalent to the head and shoulders being visible
- In the first instance we have defined a test method where the top or bottom half of the test object can be acceptable as visible to the driver (more on this later)

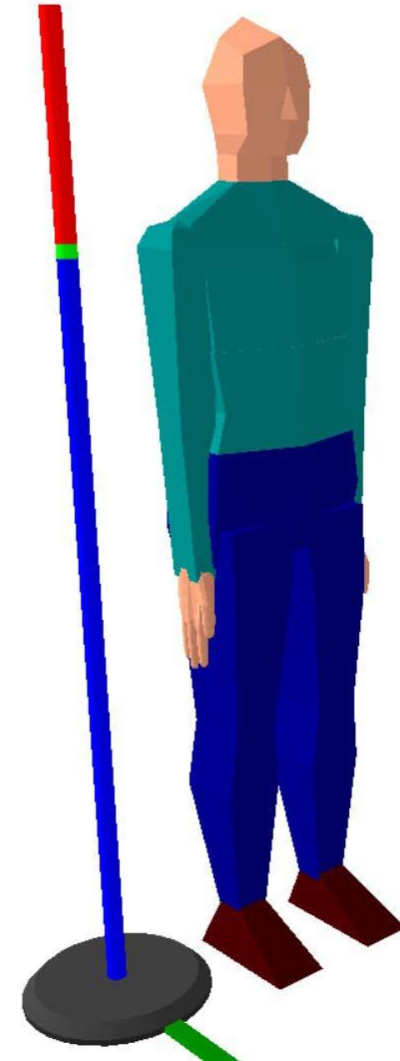

Old Method: The positions of the 'Sticks' when they are visible (head and shoulders of 5thile Italian female)

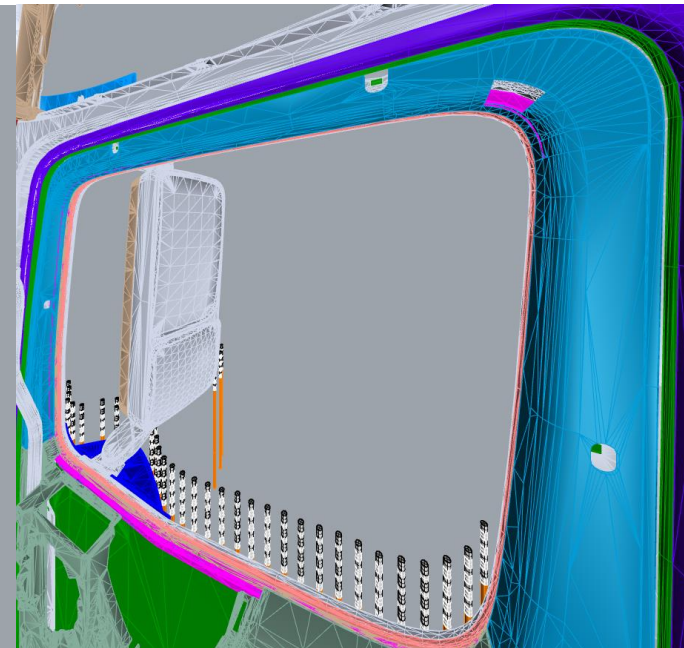
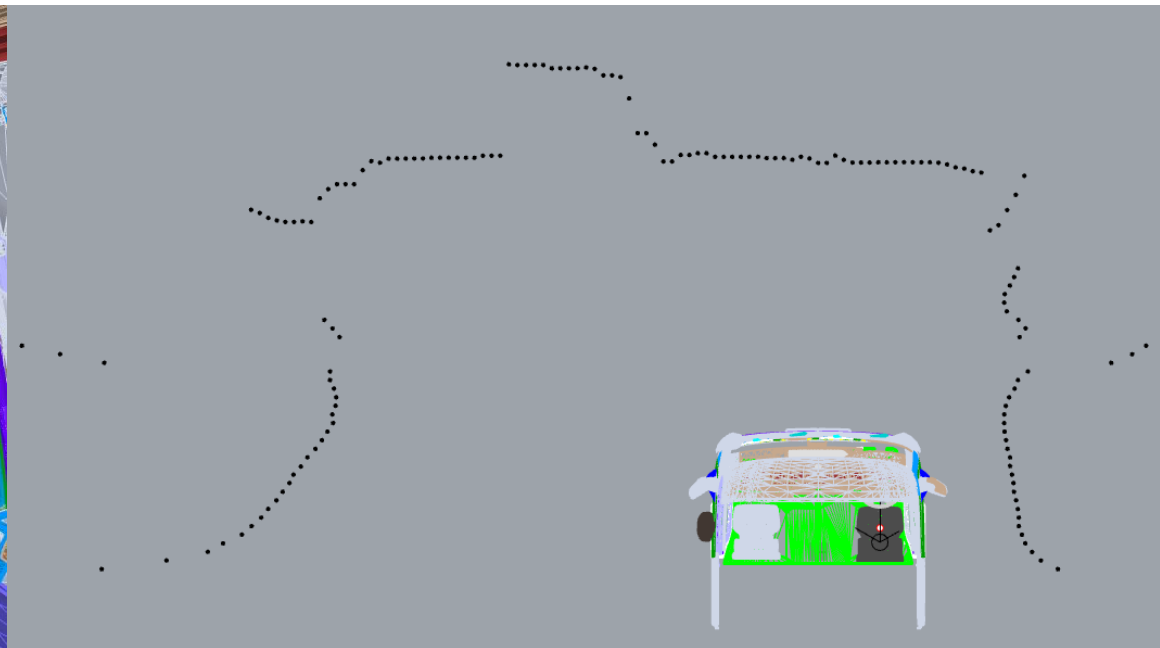
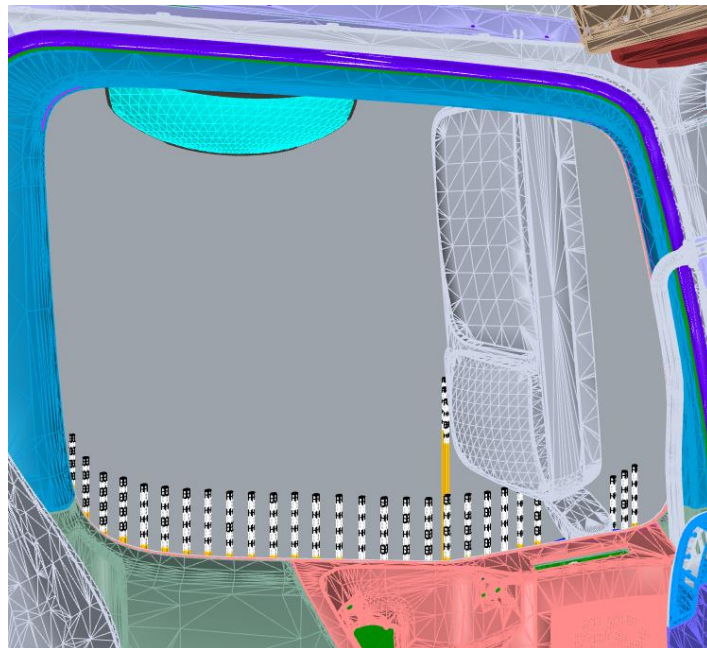

The definition of a 'real world' test that can be used for 'on the spot' checks

- At the last meeting we presented a version of the physical testing method that is currently being defined using virtual techniques
- Whilst the results were good for the method presented at the last meeting we were not happy that the method placed some vehicle 'out of order' in terms of their volumetric score. (see red and blue dotted circles on graphs)

Plotting the DVS volumetric score against the results of the 'Sticks' based method (n=27 HGVs) 0.98 Correlation coefficient

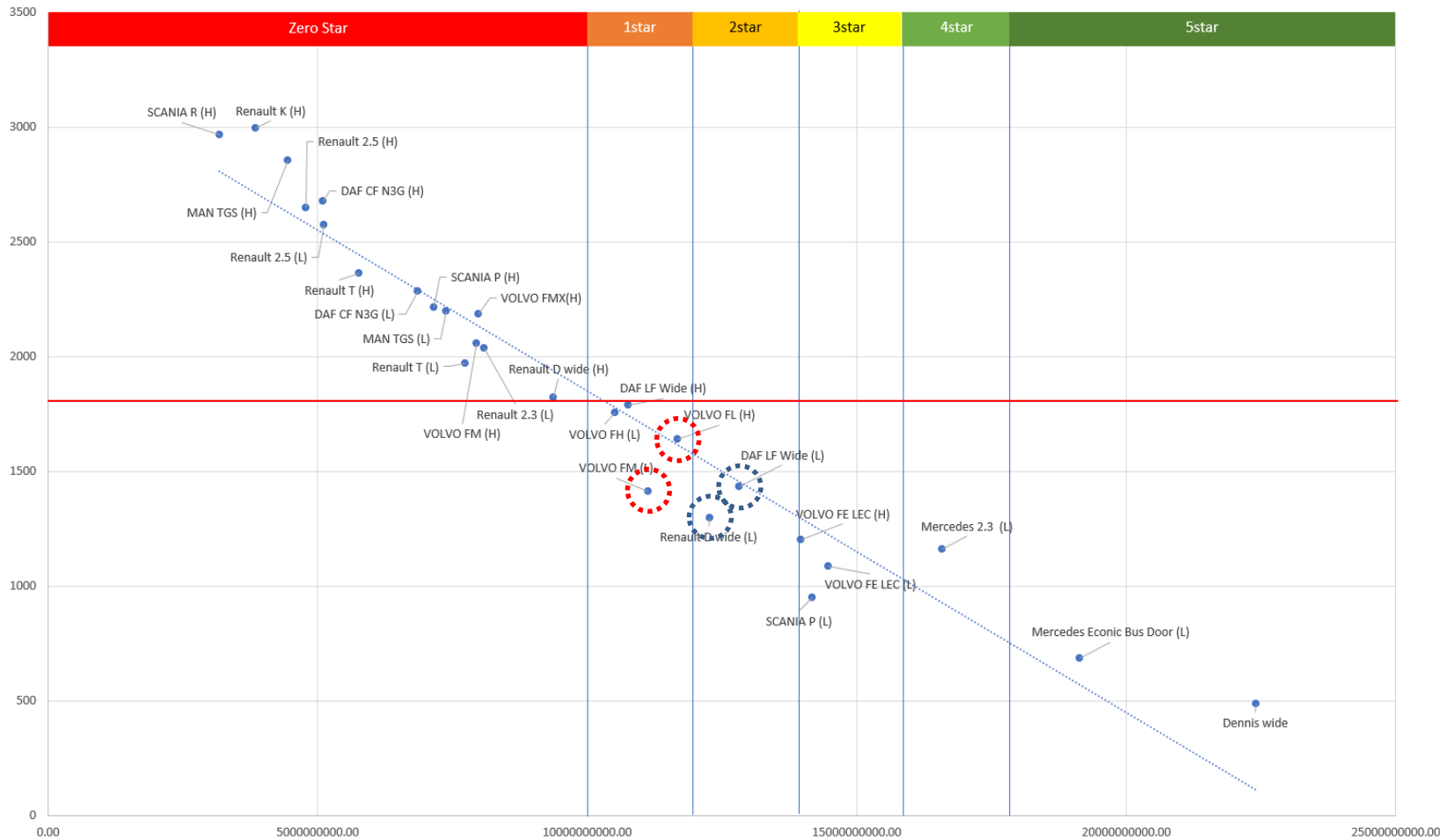

Comparing the old and new Physical testing method

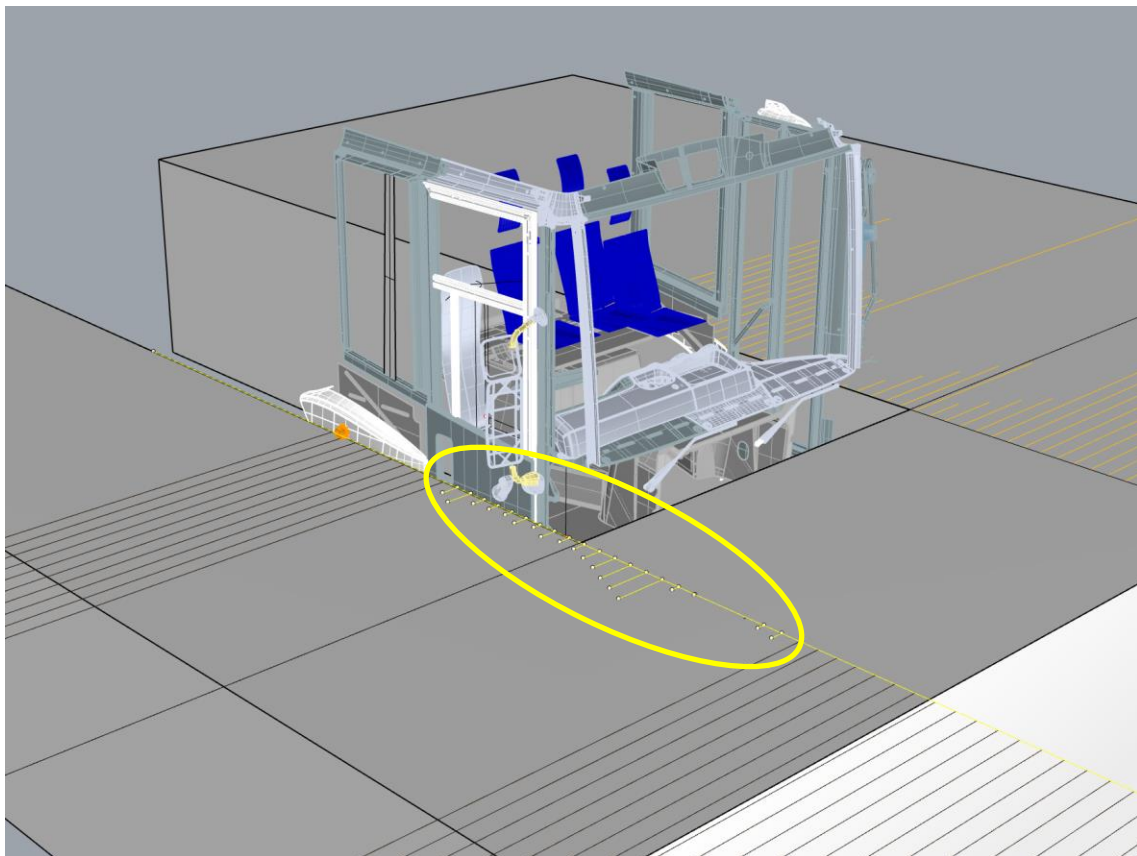

- Old stick based method simply measured the closest distance that the stick can be seen (yellow lines)

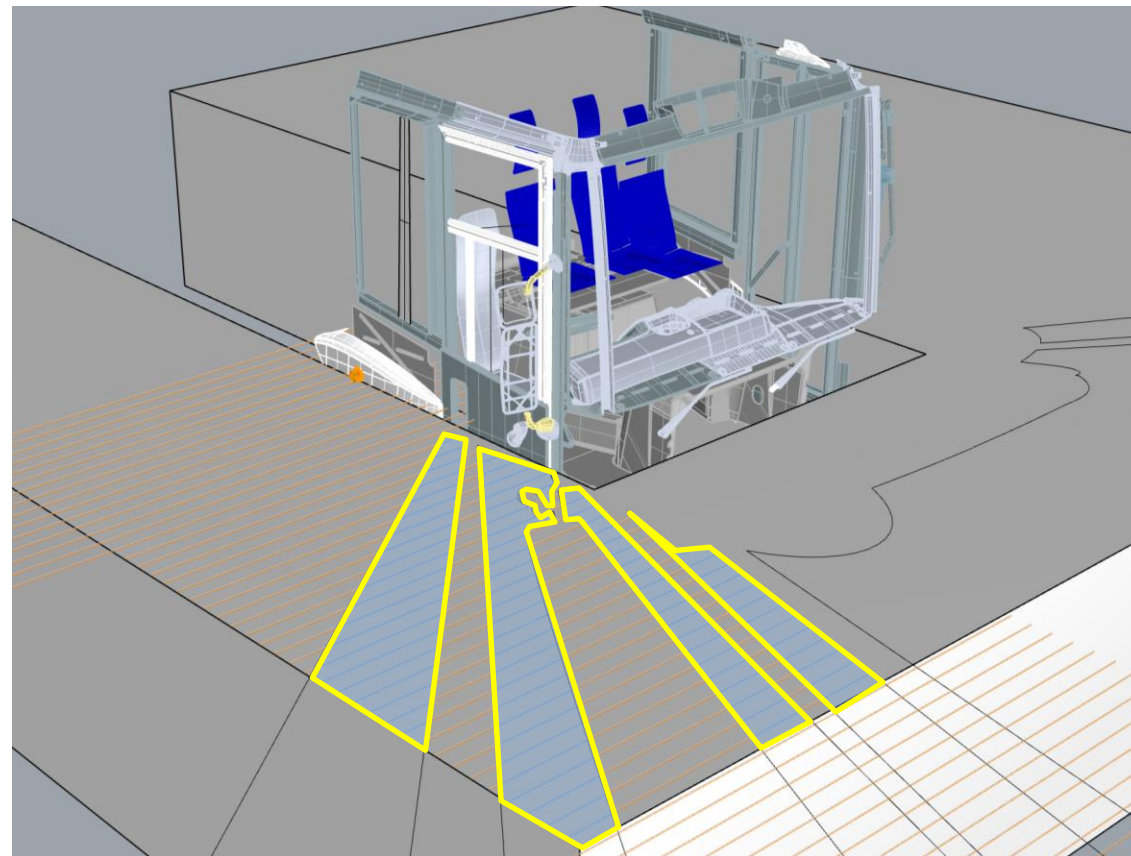

- New method measures the length of lines within the visible areas with the Direct Vision Standard Assessment volume

Comparing the old and new Physical testing method

Old method – more stick distance is worse

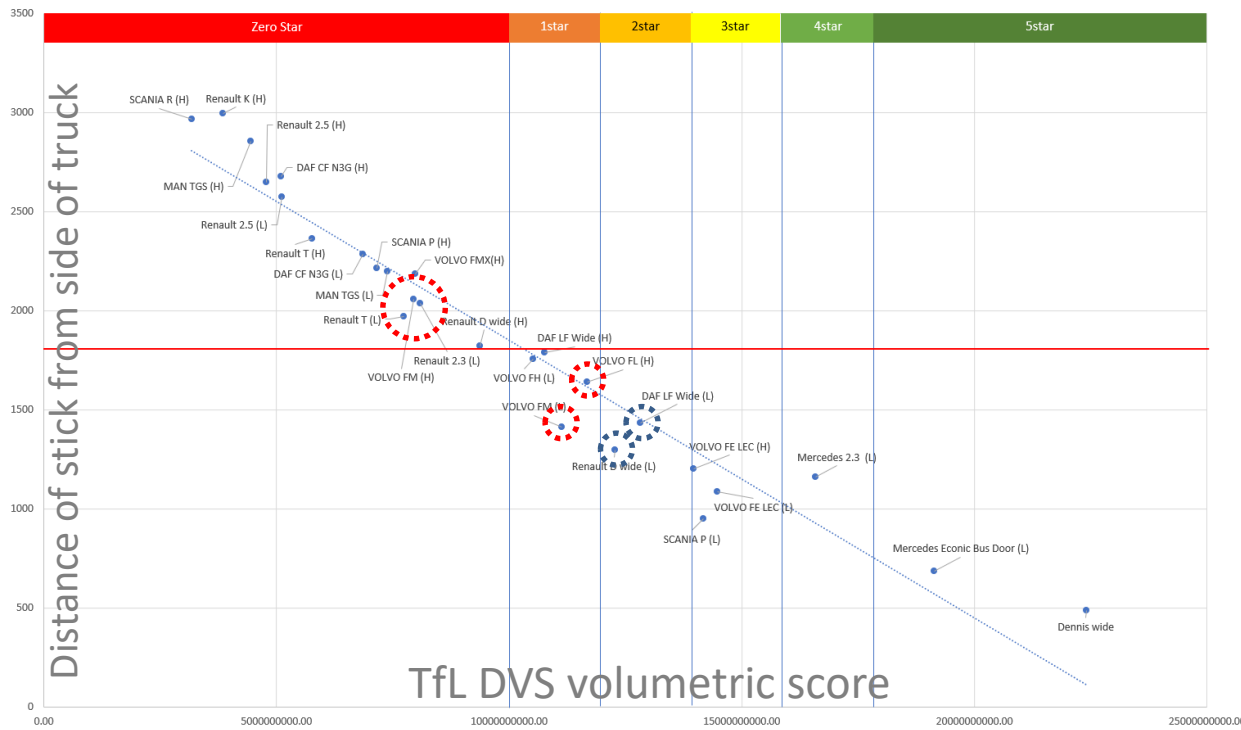

New method – more stick distance is better

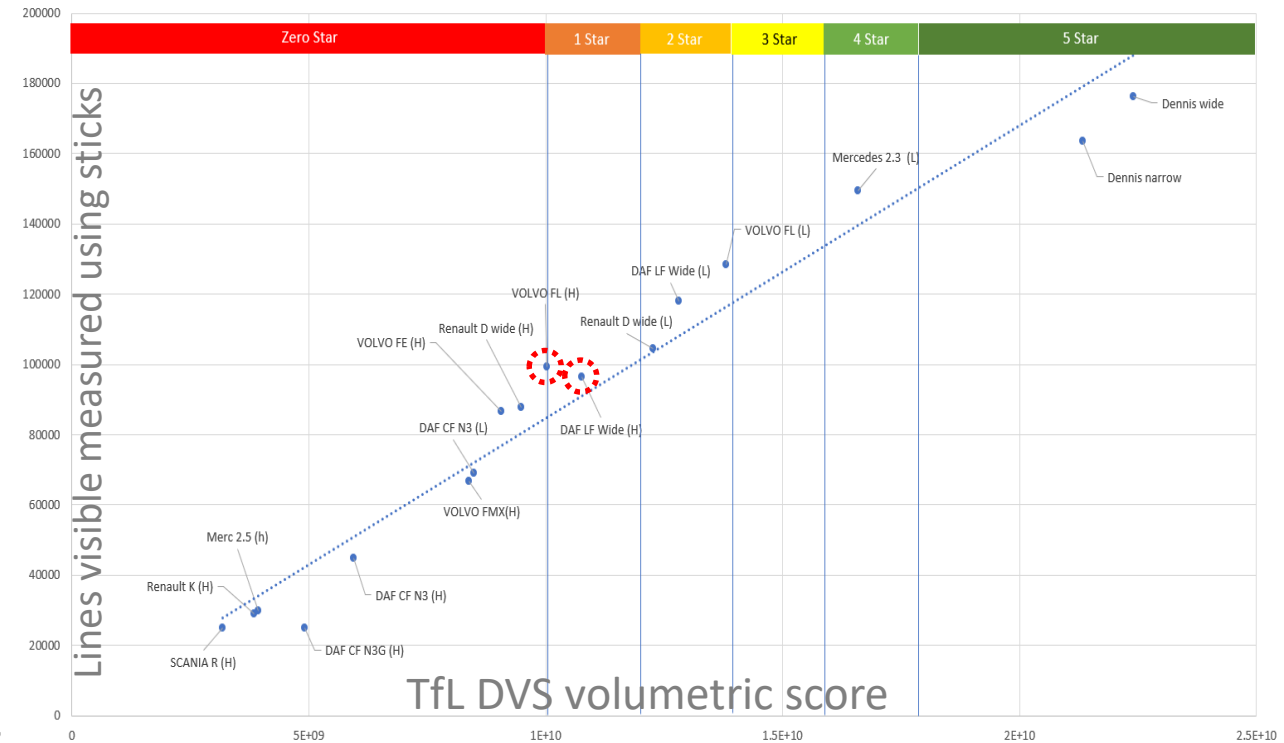

- Old method had too many cases where a the physical test stick distance took vehicles out of order compared to the volumetric score
- i.e. comparing two vehicles in the dotted circles the stick distance is not high enough to allow good correlation with the volumetric score

- New method has better correlation with the Volumetric DVS score AND has only one case where the results are out of order (this can be further improved)

Summary

- The new physical method improves the correlation with the DVS
- The new physical method increases the accuracy of modelling the digital DVS in the real world
- Further improvements can be made

Next Steps

- Complete the analysis of the remaining vehicles in the digital version
- Commission the production of the floor mats and the assessment sticks
 - 3 required
- Attempt to test the new method and see how repeatable the results are a number of experimenters in the real world (Millbrook proving ground with staff that perform similar tested for indirect vision (e.g. Reg 46 mirror type approval))
- Produce a protocol for the test and the engineering drawings required for the rig production

Project information

Thank you for your attention, are there any questions?

Dr Steve Summerskill (s.j.summerskill2@lboro.ac.uk)

Dr Russell Marshall (r.marshall@lboro.ac.uk)

Dr Abby Paterson

Anthony Eland

Dr Jim Lenard

Design Ergonomics Group

Loughborough Design School

Loughborough University