

Draft proposal for determination of system power of hybrid electric vehicles and of pure electric vehicles having more than one electric machine for propulsion

I. Statement of technical rationale and justification

A. Introduction

1. Passenger vehicles are commonly assigned a vehicle power rating, which is useful for comparing the performance of different vehicles. Vehicle power rating has also been used for other purposes such as vehicle classification, customer information, insurance, and taxation.
2. Historically, almost every passenger vehicle produced for the consumer market has been powered exclusively by an internal combustion engine (ICE). The vehicle power rating has customarily been the same as the rated power of the engine, as determined by an engine bench test. This is a convenient way to assign a power rating to a vehicle, because the engine power rating may then be applied to any vehicle that uses the same engine.
3. As a measure of real-world vehicle performance, this traditional measure is imperfect, since it does not account for the power lost in the drivetrain between the engine and the road. However, it has become well established and is generally accepted as a useful metric, in part because conventional vehicles have only one engine, and its full rated power is typically available for propulsion.
4. Today, electrified vehicles such as hybrid electric vehicles (HEVs) and pure electric vehicles (PEVs) with multiple drive motors have begun to appear on the market. A vehicle power rating is not as easy to assign to these vehicles because they combine more than one propulsion source, such as an engine and an electric machine, or multiple electric machines.
5. For these vehicles, maximum vehicle power depends on how the control system combines the power of each propulsion source when the driver demands maximum power. While it may seem that this would simply be the sum of the rated power of each component, this is not necessarily valid in practice. It will result in an overestimate if, for example, the electric machine is limited by the available battery power, or if the control system limits or reassigns some of the nominal capacity, such as to maintain traction or charge the battery.
6. Owing to the pressing need to reduce emissions of greenhouse gases (GHG) and other air pollutants, the market share of electrified vehicles is expected to grow in the future. This intensifies the need for a standard method for assigning a vehicle power rating to electrified vehicles.

7. Electrified vehicles and conventional vehicles are likely to coexist in the market for some time. Many existing regulations and procedures, such as WLTP, apply to both conventional and electrified vehicles, and require a power rating as an input. In order to be used equitably for such purposes, a power rating for electrified vehicles should be qualitatively and quantitatively compatible with the traditional engine-based power ratings of conventional vehicles.

B. Procedural background

8. The IWG on EVE was set up in June 2012 following the approval by WP.29 of ECE/TRANS/WP.29/AC.3/32. This document established two distinct IWGs to examine environmental and safety issues related to EVs (IWGs on EVE, reporting to the Working Party on Pollution and Energy (GRPE) and the IWG on Electric Vehicle Safety (EVS), reporting to the Working Party on Passive Safety (GRSP)). The proposal was supported by the European Commission, Directorate General for Internal Market, Industry, Entrepreneurship and SMEs (DG GROW), the National Highway Traffic Safety Administration (NHTSA) and the Environmental Protection Agency (EPA) of the United States of America, the Ministry of Industry and Information Technology (MIIT) of China, and Japan's Ministry of Land, Infrastructure, Transport and Tourism (MLIT).

9. A second mandate for the IWG on EVE, divided into Parts A and B was approved in November 2014 by AC.3 to conduct additional research to address several recommendations that grew out of the first mandate, and develop GTR(s), if appropriate. The second mandate was separate from the IWG on EVS.

10. The WLTP IWG had stated a clear demand for an improved power determination procedure for the purposes of classification and downscaling under WLTP. Accordingly, Part B of the second EVE mandate included a subtask to develop an amendment to Global Technical Regulation No. 15 to establish a procedure for determining the powertrain performance of electrified vehicles for use with the WLTP test procedure.

11. The EVE IWG therefore established the subgroup “Determination of electrified vehicle power” (DEVP). The goal was to clarify how an improved technical procedure for the determination of the system power of hybrid powertrains could be realized in an efficient and simple way.

12. The scope of the work covered light duty vehicles (passenger cars -M1 and light duty vehicles -N1) and aimed to develop a recommendation or regulation for determination of hybrid vehicle system power. It was agreed that the procedure shall cover all types of HEV (ordinary HEVs and plug-in HEVs) as well as PEVs with more than one electric machine for propulsion (for example, all-wheel drive configurations driven by an electric machine on each axle, or by wheel hub motors).

13. The WLTP test procedure requires a vehicle power rating for the purpose of classifying vehicles into distinct Power-to-Mass ratio classes, and for application of the so-called “downscaling method” that enables the test reference cycles to be adapted for low-powered vehicles.

14. For purposes of rating the motive power of light vehicles, the UNECE currently provides a regulation under the 1958 Agreement, known as UN Regulation No. 85 (“R85”), that can be used for approval of ICEs and electric machines for M and N category vehicles. In many cases it is sufficient to fulfil the needs of WLTP.

15. However, R85 merely determines the bench power rating for either an ICE or a single electric machine. The regulation does not establish a method to determine the total vehicle power of a hybrid vehicle, nor for a pure electric vehicle propelled by more than one electric machine. This would call for a vehicle-level test that is able to determine the maximum power output of the system as a whole.

16. The EVE IWG recognized that several organizations, including the Society of Automotive Engineers (SAE), the International Organization for Standardization (ISO), and the Korea Automobile Testing & Research Institute (KATRI), were also studying the issue of hybrid system power determination. The EVE IWG was therefore able to consider several possible paths forward for which considerable research had already occurred. The IWG received presentations from experts with these organizations and discussed the merits and drawbacks of the methods proposed by each.

17. At EVE 22, the contracting parties reached consensus that the ISO approach presented the best option as a basis to fulfill the needs of the mandate. The co-chair from Japan requested that EVE leadership take on the task of drafting the amendment. A drafting group was formed to perform this task.

18. The drafting group initially focused on converting the draft ISO standard, which was nearing finalization, into an Annex to GTR No. 15. The group made substantial progress on converting the document into the proper format and harmonizing its technical details with GTR No. 15 where necessary. The IWG also initiated and completed a first phase of validation testing to further evaluate the harmonized procedure as it was developed.

19. During this effort, a clear demand emerged on the part of several contracting parties that the procedure should be developed as a standalone GTR, in part so that it could be more easily utilized for purposes outside of the specific context of WLTP. In 2019, the mandate was therefore modified to specify development of a standalone GTR rather than an Annex to GTR No. 15.

20. Recognizing the need for a reasonable test burden, as well as the increasing diversity of electrified powertrain architectures, the EVE IWG originally considered the possibility of developing both a “reference” method

and a “candidate” method. The reference method would determine system power by means of a vehicle-level test procedure, while the candidate method would derive system power from the results of component-level tests. Initial priority was placed on the reference method over the candidate method.

21. At this time, the test procedure described herein provides for a reference method but not a candidate method. Development of a candidate method remains a possibility for future attention of the EVE IWG.

C. Principle for developing the global technical regulation

22. Discussions among the members of the EVE IWG identified a number of requirements for a hybrid system power rating:

- a) The system power rating should be comparable to the traditional engine-based power rating of conventional vehicles.
- b) Third-party verification of the power ratings developed by the method, and of any manufacturer-provided inputs to the procedure, should be readily possible.
- c) The test burden imposed by the procedure should be reasonable, so that the cost and the amount of work necessary to certify the power of an electrified vehicle should not be prohibitive.
- d) The procedure should be consistent and repeatable with little variation, to minimize the need for repeated tests and prevent opportunities for selective reporting (or “cherry picking”).
- e) The procedure should be sufficiently robust to evaluate all architectures fairly, including those that currently exist in the market, and those that may reasonably be anticipated to emerge in the future.

D. Technical Background

D.1 Primary technical challenges

23. Developing a test procedure and system power rating that fits the requirements presents two primary technical challenges:

- a) The first challenge is to identify a reliable and repeatable way to make a vehicle develop its maximum power in a laboratory setting, so that it can be measured.
- b) The second challenge is to identify a comparable and valid basis for the system power rating and to identify the measurements and calculations necessary to produce it.

D.1.a Developing maximum power

24. As part of their standards development efforts, SAE and ISO studied ways to elicit maximum power in a laboratory setting. This resulted in

identification of a reliable and repeatable method to do this by use of the fixed-speed setting of a chassis dynamometer. The condition of maximum power is determined by carrying out a series of test runs while driving the vehicle on the dynamometer at a series of fixed speeds to find the maximum brake power of the chassis dynamometer that the vehicle is able to run against. At each speed, the accelerator is rapidly and fully depressed for at least 10 seconds. Maximum system power is determined from data collected at the fixed speed at which the vehicle delivers maximum power.

D.1.b Basis and measurements

25. In early discussions, the EVE IWG discussed a number of conceptually simple measurement bases for electrified vehicle power.

26. One very simple basis would simply measure the peak power delivered to the wheels. This would be compatible with all electrified vehicles regardless of their powertrain architecture. If also extended to conventional vehicles, it would rate all vehicles on a directly comparable basis, and would represent real-world power more effectively than the traditional measure because it includes the effect of losses in the drivetrain. However, for the same reason, this would result in power ratings that are not comparable to the traditional measure, which continues to be used in many applications.

27. Another simple approach would measure the peak power delivered to the wheels and then adjust it by an assumed transmission efficiency. This approach recognizes that an engine-based power rating, in theory, should be identical to the peak power delivered to the wheels divided by the mechanical conversion efficiency of the drivetrain (e.g. gearbox or transmission). By extension, a highly comparable power rating for an electrified vehicle could be determined by measuring the peak power delivered to the wheels and dividing by a typical (conventional) drivetrain efficiency at peak load, perhaps 90 to 95 percent. However, it was not clear that this approach would represent all hybrid powertrains equally, nor that a single assumed drivetrain efficiency would represent all comparison vehicles equally.

28. Another possibility would sum the power of the engine with the measured power output of the battery. In many cases, the engine operates at full throttle when maximum power is demanded, meaning that its power can be estimated from its speed. Battery power is also reasonably simple to measure, and measuring at the battery avoids the need to instrument individual inverters or motors. However, it would neglect electrical conversion losses in the latter, and so might tend to produce optimistic results for highly electrified powertrains.

29. These simpler methods vary in their comparability and fairness, and suggest that a more sophisticated approach is needed.

30. Conceptually, a comparable and fair rating would be based on the power that passes through the powertrain at a point that is mechanically analogous to the output shaft of a conventional engine (as opposed to the

wheels or the battery, where the losses would be different). Intuitively, this point would include the mechanical output shafts of any propulsion energy converters (i.e. engine and electric machines) that contribute propulsion energy during the condition of maximum power.

31. As an example, Figure 1 illustrates a typical P2 hybrid configuration, in which engine power and motor power is mechanically combined on a single shaft. It identifies two “reference points,” R1 and R2, that together are mechanically analogous to the power output of the engine in a conventional vehicle. The ultimate goal would be to determine the sum of the mechanical power passing through R1 and R2 when the vehicle is producing maximum power.

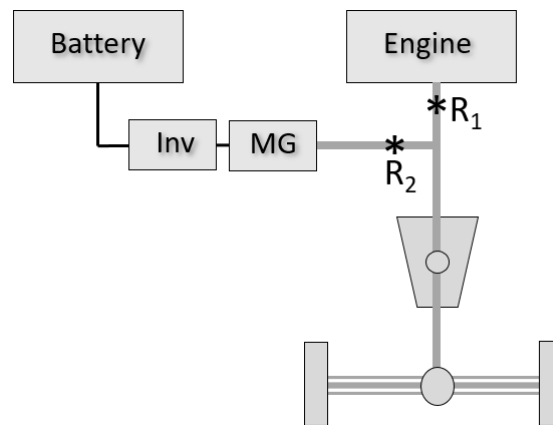

Figure 1. Example of reference points for system power determination

32. In theory, the most direct approach to measure the power at R1 and R2 would be to instrument the corresponding shafts with torque and speed meters. However, this requires invasive instrumentation, may not be possible in some cases, and is unlikely to be practical in a type approval context.

33. A more practical approach would measure power flow at alternative points along the powertrain that are easier to instrument, and estimate the power at R1 and R2 by accounting for the losses between there and the measuring points. As shown in Figure 2, the measuring points could either be upstream or downstream of the reference points. An option for measuring power at an upstream point might include measuring engine speed and battery output power, and converting these to the mechanical power output at R1, and at R2 by accounting for electrical conversion losses. Options for measuring at a downstream point might include measuring wheel power using wheel torque and speed sensors or a hub dynamometer, and then determining the sum of R1 and R2 by accounting for mechanical conversion losses in the drivetrain.

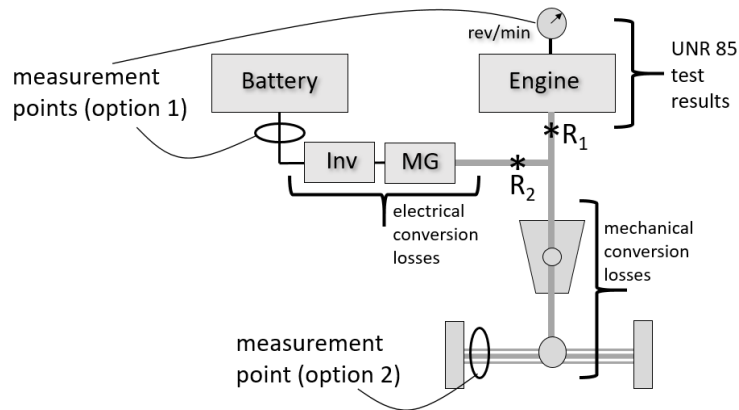

Figure 2. Possible measurement points for parallel P2 hybrid

34. Electrified powertrains vary widely, and can include power flow paths that are much more complex than those depicted here. However, once the reference points are identified, it should be possible to estimate the power at the reference points by taking appropriate measurements when the vehicle is generating peak power, and accounting for the losses between the measurement points and the reference points using component test data or sound engineering judgement.

D.2 Accuracy and precision

35. It should be noted that the traditional engine-based metric does not perfectly represent the road power available to the driver, because it neglects losses in the transmission. This also makes it imprecise, in that the road power may vary significantly from one vehicle model to another due to differences in transmission losses.

36. Engine power ratings are also somewhat imprecise. For example, ISO 1585 (and UN Regulation No. 85) allows production engines to deviate from the certified power value by up to 5 percent.

37. A power metric for electrified vehicles might therefore be considered acceptable if it bears a similar level of accuracy and precision.

D.3 Work of other organizations

38. The EVE IWG received presentations from experts with several organizations that were studying the problem of hybrid system power determination.

D.3.a SAE J2908

39. The SAE J2908 Task Force led by Argonne National Laboratory (ANL) started its project in November 2014. Three primary methods of determining HEV system power were initially investigated (referred to here as Method 1, Method 2, and Method 3).

40. SAE Method 1 was the sum of engine power (estimated from bench test results) and measured DC power from the battery (neglecting electrical conversion losses in the inverter and electric machines). SAE Method 2 was the sum of estimated shaft powers from the engine and the electric machines (determined from bench test results and onboard data, respectively). SAE Method 3 was the measured power at the axle or wheel.

41. The EVE IWG agreed with the characterization of these three primary methods as reasonable approaches to measure system power. However, the three methods varied in terms of how well the measure could be compared to the traditional power ratings for conventional vehicles, and in terms of the ability to verify a reported value. Method 1 was conceptually similar to the conventional engine-based rating and would be straightforward to verify by measurement, but neglected some losses. Method 2 was most comparable to the conventional rating, but would impose the highest burden of instrumentation to verify. Method 3 would be easily verifiable by dynamometer testing, but because a wheel power measurement accounts for losses in the drivetrain, it would not be as comparable to the conventional rating, which does not.

D.3.b KATRI standard

42. KATRI started a research project in July 2013 with the aim of developing a national standard for the determination of a representative power for (N)OVC-HEVs and PEVs with in-wheel motors. It was finalized in June 2015 and the result is expected to be harmonized with this GTR. Nominal rating and system power tests were studied using a powertrain dynamometer or a chassis dynamometer with added instrumentation. The definition of hybrid system power follows the same approach as SAE Method 1, namely that it involves a simple addition of the rated engine power and the electric power of the battery. The engine power is the rated power according to UN-R85. The electric power is the measured power of the fully charged REESS, determined by chassis dynamometer testing. Compared to the SAE methodology, it is a somewhat more sophisticated test that provides not only accurate measurement of wheel or axle power but also system torque.

D.3.c ISO 20762

43. ISO conducted a project under New Work Item Proposal (NWIP) N3477 proposed by the Japan Automobile Research Institute (JARI), approved in June 2015. It started as a formal project of ISO/TC22/SC37/WG02 and was finalized as ISO Standard 20762 in 2018.

44. The ISO method includes two alternative test procedures, referred to as test procedure 1 (TP1) and test procedure 2 (TP2).

45. As shown in Figure 3, TP1 is based on upstream measurements at the engine and battery, and TP2 is based on a downstream measurement at the wheel hubs or axle shafts.

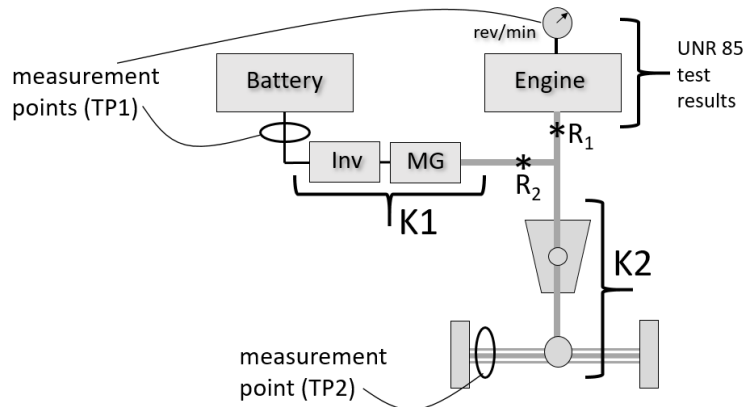

Figure 3. Measurement points for ISO test procedures TP1 and TP2

46. TP1 is similar to SAE Method 1, but additionally accounts for electrical conversion losses. Total power is the sum of estimated engine power and estimated motor power. Engine power is the rated power by ISO 1585 (or UNR 85) at the observed operating point. Motor power is based on measured battery power, adjusted by a factor (known as K1, default value of 0.85) that represents combined efficiency of the inverter(s) and electric machine(s). (Electrical power to the accessories is also estimated or measured and deducted from the battery power.) Figure 4 illustrates how total power is modeled under TP1.

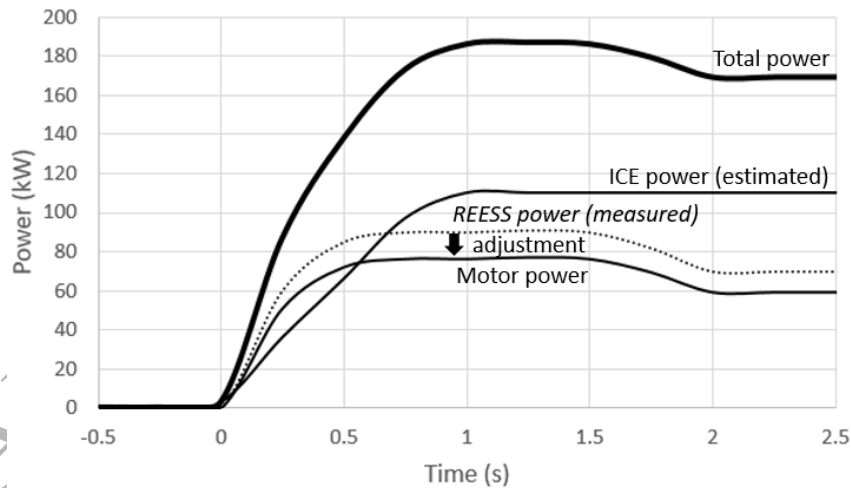

Figure 4. TP1 as sum of estimated engine power and estimated motor power

47. TP2 is similar to SAE Method 3. Total power is the power measured at the wheels or axle shafts, adjusted by a factor (known as K2) that represents losses in the gearbox. Default values for K2 are provided for a number of hybrid drivetrains. Figure 5 illustrates how total power is modeled under TP2.

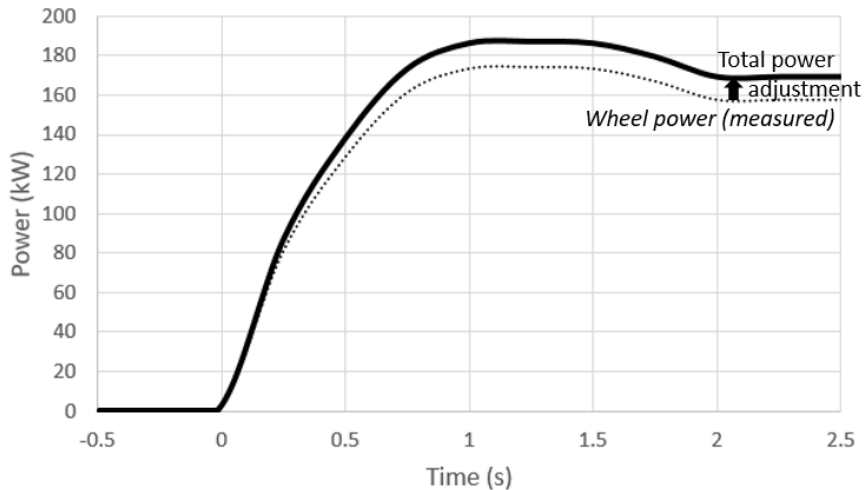

Figure 5. TP2 as measured wheel power adjusted for losses in gearbox

48. It could be said that TP1 and TP2 provide the flexibility in measurement options provided by SAE Method 1 and 3, while delivering a metric more like that of SAE Method 2, which is most comparable to the traditional measure.

49. In both TP1 and TP2, power is measured when the hybrid system as a whole delivers maximum power on a chassis dynamometer. If not provided by the manufacturer, the condition of maximum power is determined by carrying out a series of test runs while driving the vehicle on the dynamometer at a series of fixed speeds to find the maximum brake power of the chassis dynamometer that the vehicle is able to run against. At each speed, the accelerator is rapidly and fully depressed for at least 10 seconds.

50. As shown in Figure 6, the tests result in a power-versus-speed curve that helps to identify the fixed dynamometer speed at which maximum power is generated. If necessary, the evaluation is continued with smaller speed steps near the peak of the curve until the speed of the peak power is accurately identified. The power test is then performed at this fixed speed.

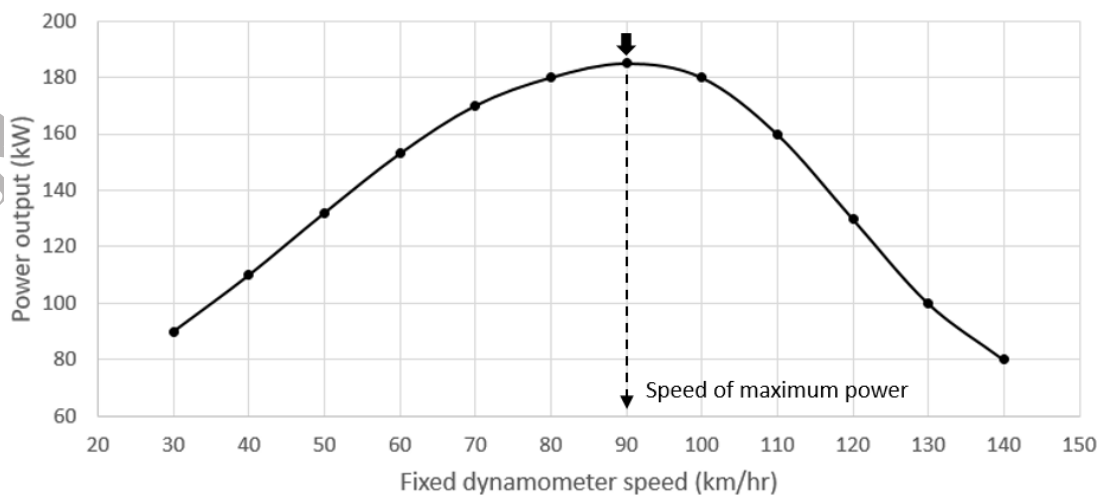

Figure 6. Identification of speed of maximum vehicle power

51. Calculations are then performed to determine the system power according to TP1 or TP2. As shown in Figure 7, a “peak” power is defined as the maximum of a 2-second moving average of the total power over a 10 second window beginning at the start of maximum accelerator command, and a “sustained” power is the average total power between the 8th and 10th seconds.

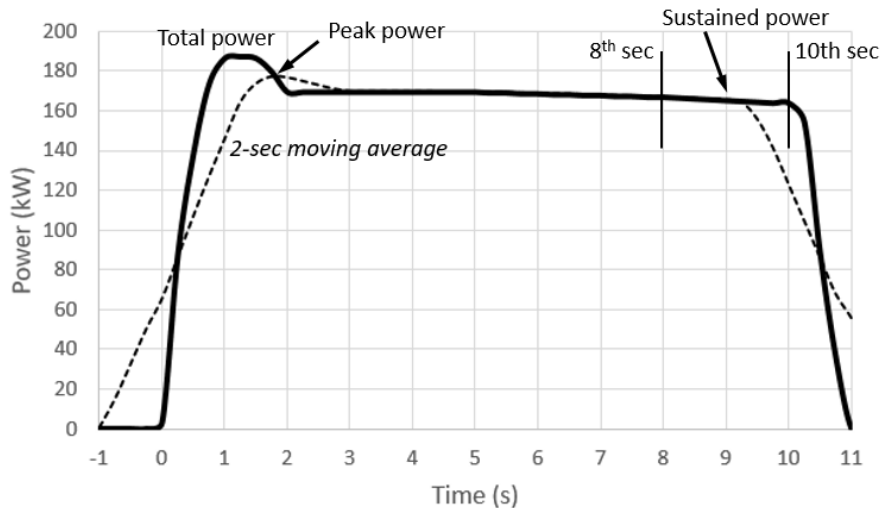

Figure 7. Definition of peak and sustained power

D.4 Selection of ISO methodology

52. The EVE IWG recognized that the ISO method showed good comparability, flexibility, and verifiability. At EVE-22, the contracting parties reached consensus that the ISO approach presented the best option as a basis to fulfill the needs of the mandate.

D.5 Integration and validation

53. The EVE IWG then turned attention to aligning and integrating the ISO method with GTR No. 15 or a new GTR. There was some debate as to whether the GTR should select only one of the ISO test procedures (TP1 or TP2) or retain both options. It was generally decided that retaining both would be preferable because it would accommodate variations in vehicle instrumentation possibilities and differing laboratory capabilities or preferences.

54. The EVE IWG recognized that retention of both procedures meant that differences between the two test results should be minimized in order to prevent inconsistent results and the opportunity for selective reporting (or “cherry picking”).

55. In designing and validating the ISO method, the ISO committee placed strong emphasis on its practicability. Testing at the Japan Automotive Research Institute (JARI) indicated that the procedures delivered equivalent results for a variety of HEVs, although TP2 was thought to show somewhat greater variability than TP1. Discussion in the IWG suggested that the relative variability may be the result of TP2 being based entirely on measured data, while a large component of TP1 relies on a fixed value for engine power obtained from the R85 rated power. If so, then the relative variability may be a natural outcome of differences in the procedures.

56. The EVE IWG recognized that additional validation testing would be necessary to assess this variability, and also to validate the ability of the aligned ISO method to fulfil the specific needs of a regulatory application.

57. Several contracting parties volunteered to perform validation testing, including Environment and Climate Change Canada (ECCC), Joint Research Centre (JRC), U. S. Environmental Protection Agency (EPA), and KATRI.

58. A first phase of the validation program was initiated at the April 2018 EVE meeting in Tokyo. Japan reviewed the testing performed on three HEVs in conjunction with the ISO standard development in 2016. A matrix of additional HEVs that were available for testing was compiled. US EPA offered to perform testing of a BAS hybrid and a power split PHEV. Canada offered to perform testing of a later generation power split HEV, a P2 hybrid, and a two-motor PEV. KATRI offered to perform testing on a P2 hybrid. JRC offered to perform testing on two parallel hybrid vehicles provided by representatives from Volvo and Hyundai.

59. Japan arranged for consultation with the engineer who performed the ISO validation tests in Japan. A detailed technical report on this testing had been prepared in Japanese. Canada agreed to arrange for translation of the report into English. JRC scheduled an initial round of testing at the facilities in Ispra, Italy in 2018, which was attended by representatives from USA and Japan as well as technical support personnel from Volvo and Hyundai.

60. Due to the short time frame available, and the knowledge that the ISO committee had already performed significant validation, the validation testing focused primarily on practicability of the procedure as currently written, and the effect of default assumptions and available flexibilities on the consistency of the results. To save time, testing was limited to vehicles that were readily available at the participating test labs and calculations were performed using the specified default values for K1 and K2. In some cases, measurements were gathered from onboard systems rather than instrumentation due to resource constraints. While the measurements were believed to be sufficiently accurate, it was not always possible to validate onboard measurements for accuracy.

61. The results of the first phase of validation revealed significant and unexpected differences between the results of TP1 and TP2 for many of the vehicles tested. Accordingly, the work of the IWG began to focus on

identifying the sources of these differences, their implications, and how to reduce or eliminate them.

D.6 Sources of differences between TP1 and TP2

62. The EVE IWG identified several potential sources for the observed differences:

- a) Variation in accuracy of default values for K1 and K2 as applied to specific vehicle models.
- b) Uncertainty in accuracy of measurements and measurement options.
- c) Variation in power of production engines compared to R85 test results.
- d) Influence of powertrain architecture on necessary measurements to perform TP1 or TP2 in an equivalent manner.

D.6.a Default values for K1 and K2

63. For a given powertrain architecture and vehicle model, the relative accuracy of the default values for K1 and K2 are likely to vary, leading to differences in the accuracy with which each TP accounts for losses, and thereby leading to a difference in the results.

64. In particular, the default $K1=0.85$ sometimes appeared to produce lower power ratings for TP1, depending on the fraction of total power contributed by electricity. For one vehicle that was propelled entirely by electrical power, the default value resulted in TP1 being smaller than the power measured at the wheels (which would erroneously suggest a drivetrain efficiency greater than 100 percent). Modifying the K1 value to a different value still consistent with the powertrain design made the result much closer to that of TP2.

65. For some powertrain architectures, the applicable default K2 factor for TP2 was unclear. Two of the test laboratories independently chose to employ different K2 values for an architecture that included series and parallel elements.

66. It was anticipated that the predefined list of default K2 factors may be insufficient to represent potential architectures that may emerge in the future. In particular, Japan pointed out that it is uncertain whether the default value for K2 would apply to different variations in power split hybrid architectures.

D.6.b Accuracy of measurements

67. Some of the validation tests relied on TP1 measurements that were based on onboard network data that could not be verified because physical instrumentation for current and voltage was not available. While believed to be accurate, any inaccuracy could have produced variation in TP1 relative to TP2.

68. Measurements for TP2 were taken from dynamometer rollers and included losses from rolling resistance and tire slippage. While the test procedure permits the use of roller data if tire losses are accounted for, it does not specify a method for determining tire losses. Evidence of slippage was observed, which may have introduced additional unaccounted losses.

D.6.c Variability of R85 engine power

69. For TP1, engine power may vary when estimated from R85 test results. The power output of production engines certified under R85 is permitted to vary by as much as 5 percent from the certification result, potentially leading to an error of up to 5 percent even if the measured engine speed and intake manifold pressure are perfectly accurate. This uncertainty is unique to TP1 and so could contribute to the observed variation between TP1 and TP2.

70. The estimation of engine power based on measured speed relies on the assumption that the engine is operating at its maximum power for that speed, and that the power can be accurately reconstructed by reference to engine test results (e.g. R85). Measurements of intake manifold pressure and fuel flow rate are also compared to the engine test result to verify that the engine operating state is consistent with maximum power. However, the test procedure does not specify the permissible variation, leading to additional uncertainty in the engine power estimate.

71. Some experts noted that intake manifold pressure is not highly sensitive to power output at the constant engine speed that results from the procedure, and therefore it is not highly effective at confirming the result. It was recommended that measurement of fuel flow rate also be required for verification of R85 engine power.

D.6.d Influence of powertrain architecture

72. ISO 20762 does not mention the concept of reference points, but reference points are implied by the details of the procedure. For some powertrain architectures, TP1 and TP2 may estimate power at slightly different reference points, leading to a potential for variation between the results.

73. As shown in Figure 8, both TP1 and TP2 apply well to a parallel P2 HEV. Here, the system power is the sum of the power at R1 and R2. The K1 and K2 factors represent the conversion efficiencies of simple component combinations, and so are relatively simple to determine and verify. TP1 determines engine power at R1 by reference to speed and R85 results, and determines the power at R2 by measuring power from the battery (subtracting accessory power) and applying the K1 efficiency factor. Alternatively, TP2 determines the sum of the power at R1 and R2 by measuring power at the axle shafts and applying K2. If the applicable measurements and K factors are equally accurate, TP1 and TP2 should always deliver the same answer for the sum of R1 and R2.

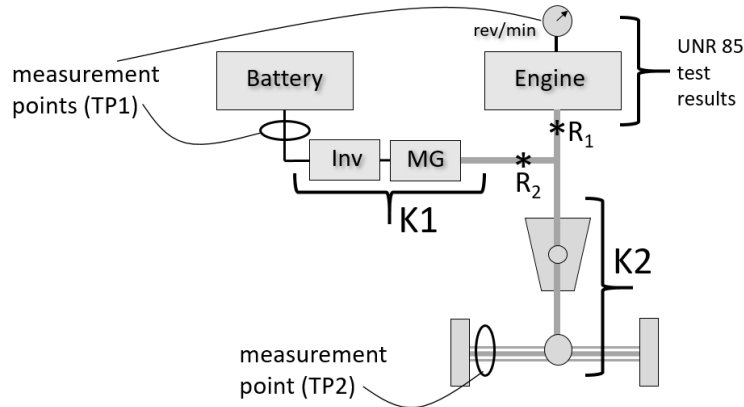

Figure 8. Parallel P2 hybrid with one motor, measurable by TP1 and TP2

74. However, in the case of some other architectures, the specified measurements for TP1 or TP2 may be difficult to convert to a common reference point.

75. As shown in Figure 9, the Toyota Hybrid System (THS) utilizes a planetary gearset with multiple inputs and outputs. Under maximum power demand, engine power enters through the planet gear carrier (P), then is split between the Ring gear (where it goes directly to the wheels) and the sun gear S (where it enters a series path that eventually delivers additional torque to the Ring gear for delivery to the wheels).

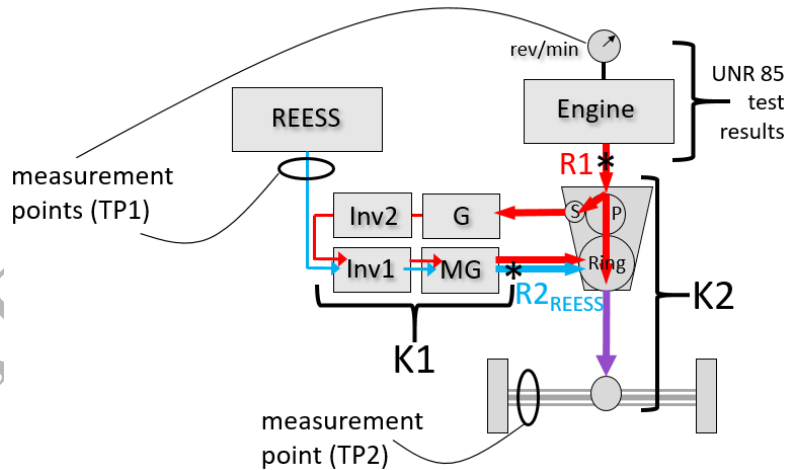

Figure 9. Power split hybrid, ambiguous under TP2
 P = planet carrier and gears; S = sun gear; Ring = ring gear

76. With careful consideration, reference points that are most comparable to a conventional vehicle can be identified. Placing a reference point at R1 accounts for the contribution of the engine. From here, the engine power splits to the series path and the direct-to-wheels path, which together may be considered as a sort of electro-mechanical transmission.

77. Another reference point must be established to account for the contribution of the REESS. REESS power emerges at the output shaft of motor MG; however, at this point it has been combined with power contributed by the engine series path (which is already accounted for via R1). The second reference point is therefore called $R2_{\text{REESS}}$ which represents the portion of MG power that is attributable to the REESS.

78. TP1 is straightforward for this architecture. The power at R1 is determined from R85 results, and $R2_{\text{REESS}}$ is the REESS power multiplied by K1 (where K1 could be the electrical conversion efficiency of the total power flow through Inv1 and MG). System power is the sum of R1 and $R2_{\text{REESS}}$.

79. TP2 relies on a measure of total power at the axle shafts or wheel hubs, to which it seeks to apply a K2 efficiency factor to account for gearbox losses. But here, the power has arrived via two different paths from the engine, and a third path from the REESS, all of which will experience different conversion efficiency. The combined power measurement does not identify the share of power along each path, so there is not enough information to individually reconstruct the power at R1 and $R2_{\text{REESS}}$ even if the conversion efficiency of each path is known.

80. Another option is to compute $(R1+R2_{\text{REESS}})$ rather than each individually. This would require a “net” K2 factor that accounts for the total losses along all three paths. If all three paths have the same conversion efficiency, it is not necessary to know the power along each path. But that is not the case here. While the manufacturer might be able to experimentally determine a “net” K2, it would not be possible to verify using the data that is collected by TP2. If the K2 factor were to represent anything other than this “net” factor, such as for example just the efficiency of the mechanical direct drive path, then it would not reconstruct the power at either of the designated reference points.

81. This is another way of saying that ISO TP1 and TP2, when applied to a power split hybrid, might determine the power at slightly different reference points. When considered individually, either of the results might be reasonable as a system power rating. However, they cannot be expected to be the same if TP1 and TP2 do not refer to exactly the same reference point.

82. This situation is seen more clearly in Figure 10, for a pure series hybrid. TP2 would measure the power at the wheel hubs and apply a K2 factor to account for losses in the gearbox, thereby reaching reference point $R2_{\text{TOT}}$ and reporting that as the system power. In contrast, TP1 would sum the mechanical power from the engine (at R1), and the REESS contribution to the torque at motor MG (at $R2_{\text{REESS}}$). The power at $R2_{\text{TOT}}$ is bound to be different than at $(R1 + R2_{\text{REESS}})$.

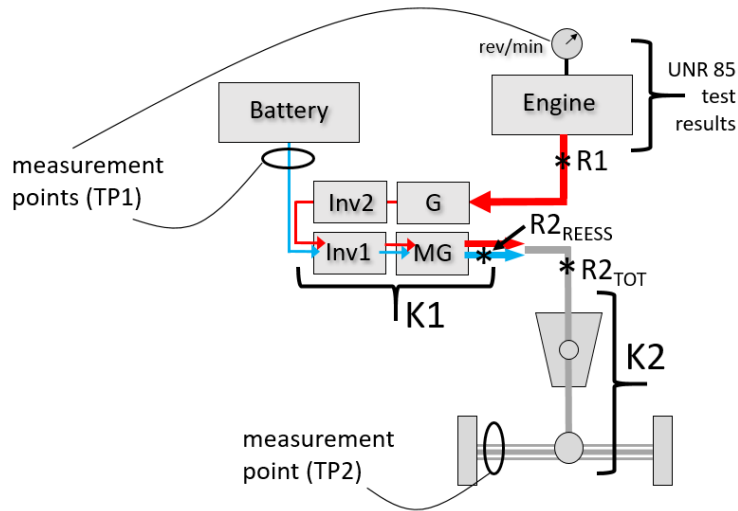

Figure 10. Inconsistent reference points for TP1 and TP2 for pure series HEV

83. As a side effect, the power measured by TP2 at $R2_{TOT}$ will always be lower than for TP1, because the power at $R2_{TOT}$ has been reduced by losses in the electrical conversion path ($G+Inv2+Inv1+MG$), while TP1 considers them to be part of the allowable gearbox losses past $R1$.

84. For HEVs with user selectable modes, the considerations in applying TP1 and TP2 can vary depending on the operating mode. Figure 11 and Figure 12 shows two high-power modes of the Generation 2 Chevy Volt powertrain, one for a pure electric (CD) mode and another for a CS mode.

85. In CD mode, both TP1 and TP2 can be performed (with certain assumptions). TP1 can determine both $R1$ and $R2$, assuming that the power into each inverter is measured, or if the conversion efficiency of both electrical conversion paths is very similar. TP2 can determine $(R1+R2)$, assuming that the efficiency of each sun-to-planet gear path is very similar, which would mean that the relative power flow through each path need not be determined (as this information is not collected).

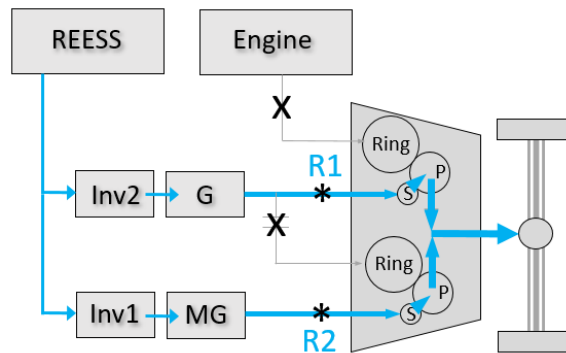

Figure 11. Volt Gen 2 charge depleting Mode 2 (CD2)

86. In CS mode, the power flow paths are different. TP1 can determine $R1$ and $R2$ easily. TP2 can determine $(R1+R2)$ as before, but only if the efficiency of the Ring-to-planet and Sun-to-planet gear paths are very similar. Otherwise, the relative power flow from the engine and the motor would need to be determined and is not collected.

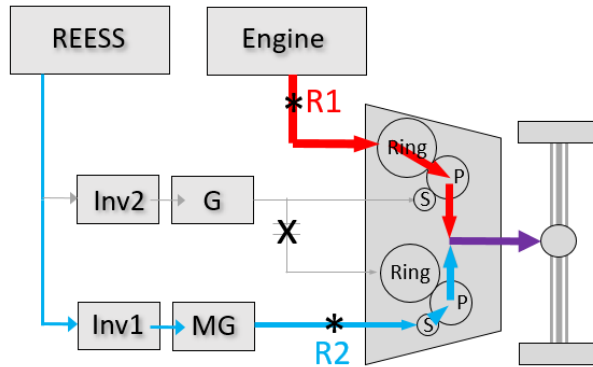

Figure 12. Volt Gen 2 charge sustaining mode 2 (CS2)

87. Even when the reference points are clear, some powertrain architectures may pose special challenges to one or the other TP.

88. As shown in Figure 13, TP1 measures power out of the battery, but does not account for how this power is divided downstream, between the two parallel inverter/motors (this was also seen in Figure 11). This means that the $K1$ factor must account for the combined losses in both inverter/motor combinations. Although the manufacturer might be able to experimentally determine and provide such a factor, it could not be independently verified from efficiency data without measuring the individual power flows.

89. Rather than measuring only the battery power, it would be more effective to measure the power into each inverter, and apply a separate $K1$ factor for each inverter/motor combination. In this case each $K1$ factor could be independently verified because the power flows are known.

90. In contrast, TP2 does not have a difficulty with this configuration, assuming that an accurate $K2$ factor is provided and can be verified.

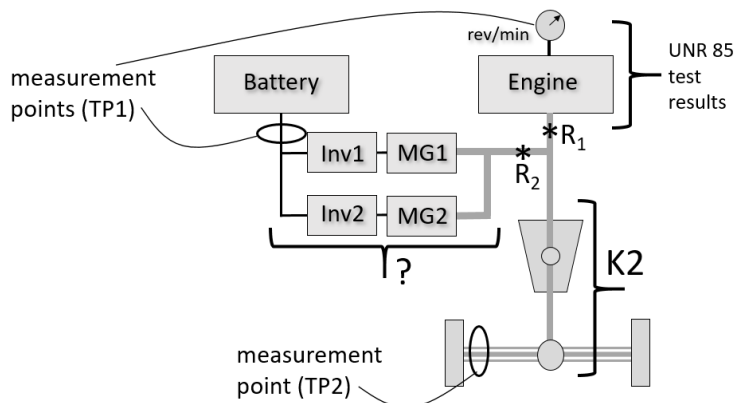

Figure 13. Parallel P2 hybrid with two motors, more difficult for TP1

91. Figure 14 shows an example HEV with two powered axles. Here a four-wheel-drive dynamometer would be needed, and the power measured at each axle separately. The reference points on the first axles are marked R1 and R2, and on the second axle, R3. TP2 is straightforward for each axle (although it does require a unique K2 factor for each axle). TP1 can be performed if the measurement points include the inputs to each inverter (Inv1 and Inv2) and two K1 factors are provided.

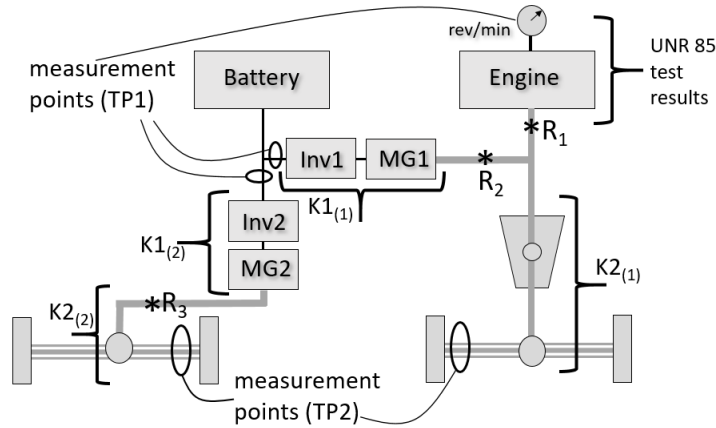

Figure 14. Vehicle with two powered axles

92. However, as shown in Figure 15, a small change to the configuration makes it very difficult to apply TP2. Here R3 represents the torque output of wheel hub motors which now contribute to powering the first axle. The power flows and losses in the wheel hub motors at R3 are likely to be different from those in the gearbox, but TP2 measures only the combination. It may be difficult to derive a K2 factor that represents the losses in both, and it would not be verifiable without measuring both power flows separately.

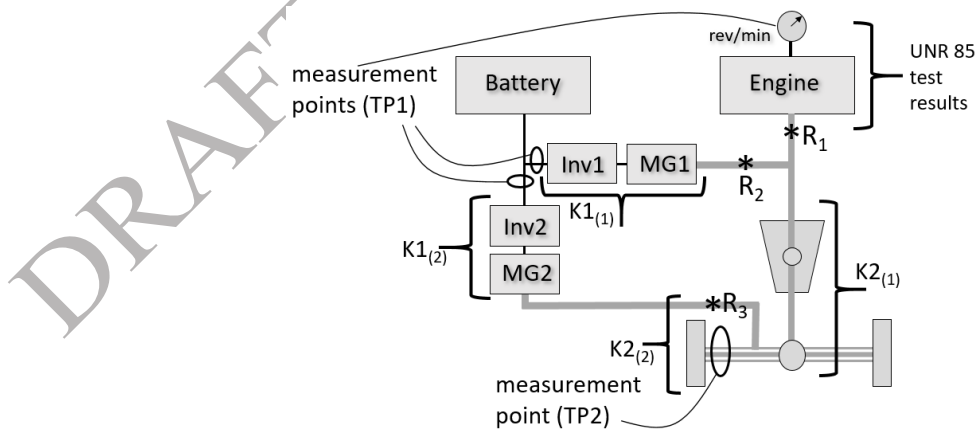

Figure 15. Configuration with difficulty for TP2

93. At EVE 30, the IWG requested that experts from VDA ([German Association of the Automotive Industry](#)) who were involved with development of the ISO procedure provide input on the difference between TP1 and TP2. VDA delivered a presentation at EVE 31 addressing this topic and providing recommendations for the second phase of validation testing.

94. The VDA experts acknowledged that some of the deviation could be the result of default K1 and K2 factors, but felt that it was more important to verify that the measurement requirements and accuracies described in ISO 20762 are followed.

95. VDA also stated that TP1 and TP2 can be expected to give the same result for parallel hybrids, which is consistent with the discussion in the previous paragraphs.

96. For pure series or mixed (power split) hybrids, VDA stated that TP1 will always give a higher result than TP2 because TP1 does not account for electrical conversion losses in the series portion. This observation is explained by the difference in the reference points implied by TP1 and TP2 for power split and pure series hybrids, as discussed in the previous paragraphs. Defining the reference points as depicted in Figure 9 would address this concern, [although it may make TP2 difficult to apply.](#)

D.7 Reconciling TP1 and TP2.

97. The EVE IWG recognized that the need to reconcile TP1 and TP2 was a significant outstanding issue for the completion of the GTR. At EVE30 in Stockholm, the IWG considered several options for completing the GTR.

98. One possibility was to accept the difference between TP1 and TP2, and add interpretive text to the GTR to help users understand the difference. This would maintain the flexibility of the procedure, minimize divergence from ISO 20762, and reduce the likelihood that the difference could be misunderstood or deliberately misused. This option found little support.

99. Another possibility was to eliminate the difference by modifying the GTR to define only a single possible result, rather than two. This might be done by any of:

- a) including only TP1 or TP2 in the GTR;
- b) requiring both TP1 and TP2, and reporting the average, the lower, or the higher of the two;
- c) retaining the nominal choice of TP1 or TP2, but validating the result by performing the other TP as a consistency check;
- d) specifying TP1 for some HEV architectures and TP2 for others.

100. (a) The IWG was reluctant to eliminate either TP1 or TP2 entirely, due in part to the flexibility it affords and preferences among members for one or the other procedure.

101. (b, c) The IWG was reluctant to require both TPs to be performed because this would increase the test burden. Also, it was noted that the best choice among an average, lower, or higher of the two results would depend on the intended purpose of the measure. For downscaling and classification under WLTP, selecting the higher figure might be preferable because it would prevent excessive downscaling. But for customer information, the lower figure might be preferable to prevent exaggerating the available power. It was unclear if there was a valid technical justification for selecting either figure, or an average of the two, when it remained uncertain which result is most accurate for a given vehicle.

102. (d) The IWG remained open to the possibility of assigning TP1 and TP2 to specific powertrain types, given a clear technical justification.

103. A final possibility was to modify the procedure to minimize the difference between TP1 and TP2 as much as possible.

104. Because the problem is essentially one of physics, it should be possible to define TP1 and TP2 so that they deliver comparable results in all cases, if the following is true: (a) the power flows in the vehicle are correctly understood, (b) the reference points are correctly identified and consistent, and (c) the measurements and K factors are sufficiently accurate to estimate the power at the reference points.

105. The question is to what degree the procedures for TP1 and TP2 can provide for this outcome while remaining practical to implement. For example, if successfully applying TP1 sometimes requires instrumentation of several inverter inputs rather than only the battery output, or if successfully applying TP2 requires knowledge of relative power flows that are not measurable at the wheels, the instrumentation burden may become prohibitive.

106. At EVE 30 and 31 it was generally agreed that the difference between TP1 and TP2 should be reduced as much as possible by modifying the procedures, and that limiting certain architectures to TP1 or TP2 could also be considered. Several proposed modifications were identified to be evaluated in a second phase of validation testing.

D.8 Modifications to the procedure

107. The IWG reached consensus on several proposed modifications to reduce the difference between TP1 and TP2:

- a) The option to use default K factors was replaced with a requirement that the manufacturer provide an accurate and verifiable K factor specific to the vehicle under test.

- b) The option to conduct TP2 using chassis dynamometer roller data was removed, in favor of axle or wheel hub instrumentation for torque and speed, or a hub dynamometer.
- c) The procedure was clarified to require that current and voltage, if obtained from onboard systems, must be shown to be accurate by means of instrumentation (TP1).

108. The drafting group also proposed several changes to be trialed in the second validation phase:

- a) To reduce the possibility of variation, five repetitions of the power test are conducted and an average taken of the last four results. See text at Section II.6.8.6.
- b) A decision tree was added to determine the permissible application of TP1 and TP2 based on aspects of the power flows between the measurement points and the reference points, and any need for additional instrumentation to enable one or the other TP. See proposed text at Section II.6.1.1.3.
- c) A requirement was added to document by means of a schematic the flow of propulsion power through the powertrain of the vehicle during the maximum power condition, the proposed measurement points and reference points, and applicable K factors for TP1 or TP2. See proposed text at Section II.6.1.1.1.
- d) The term “reference point” was introduced and defined. Draft guidelines for identifying the reference points for the common architectures was provided in Annex 1.

109. The new requirement that K factors be furnished by the manufacturer means that it must be possible for the manufacturer to determine the relevant K factor, and for a third party to verify it by a standard method.

110. The IWG considered that for TP1, test standards exist for the measurement of inverter and motor efficiency (K1), which could be used by the manufacturer to derive the K1 factor as well as by a third party to verify it. However, no similar test standard exists for gearbox efficiency (K2).

111. VDA was asked to provide a recommendation for a standard method for determining K2 for TP2. VDA recommended that any of various engineering methods could be employed, based on measurement of power in and power out on a test bench, and dividing output power by input power.

112. However, the larger issue remains that the “net” K2 for a complex power split gearbox with multiple inputs or outputs (as discussed at Figure 9 and also seen in Figure 11 and Figure 12) may be difficult to determine and the value may only apply to the specific operating state encountered at maximum system power.

113. The IWG also considered a proposal that a K2 factor might be determined (or verified) by performing TP1 using a known accurate K1 factor, and then solving for K2 by setting the result of TP1 equal to the result of TP2. A similar tactic might also be usable for internal validation of a test result. This approach was to be further evaluated with data from the second phase of validation.

D.9 Second phase of validation testing

114. In Fall 2019, a second phase of validation testing is to be completed. The test laboratories were requested to implement the following changes to the test program:

- (a) conduct TP2 with torque and speed data from torque and speed sensors rather than dynamometer roller data
- (b) conduct TP1 with current and voltage data collected from current and voltage instrumentation, in addition to onboard data
- (c) if more than one electrical power path is present downstream of the battery, then instrument the inputs to each inverter (if possible)
- (d) seek measurements of electrical power to non-propulsion accessories
- (e) improve precision of wheel speed and dynamometer roller speed to identify presence of wheel slippage;
- (f) if significant wheel slippage is observed, add weight to the vehicle to eliminate it, particularly if slippage might affect the shifting or other behavior of the vehicle.

115. In most cases, K factors will not be available. Outside of a type approval or certification context, manufacturers are unlikely to have suitable data already prepared and little incentive to produce it. Even if K factors were provided, their usefulness in validating the procedure would be limited unless they could be independently verified (which is not within the scope of the program). Instead, the results are to be evaluated by considering the ability for reasonable K factors to make the results of each TP consistent with each other.

116. ~~[list the vehicles that were tested by each laboratory]~~ For the second phase of validation, ECCC tested: a 2018 BMW 530e (NOVC-HEV), a 2016 Chevrolet Volt (OVC-HEV), a 2018 Toyota Prius Prime (OVC-HEV), and a 2009 Saturn Vue (mild BAS NOVC-HEV). JRC expressed an intention of testing two additional vehicles, and as of Autumn 2019 were continuing efforts to procure suitable vehicles and provide them with necessary instrumentation. US EPA had intended to test two additional vehicles, but damage to one of the vehicles, and an unexpected difficulty with the funding mechanism for contract work necessary to instrument the vehicles, made it impossible for EPA to test any vehicles.

117. ~~[follow up with findings once known]~~ As of January 2020, the only validation test results that are complete are for two of the vehicles tested by

ECCC. At the interim EVE teleconference of 12 December 2019, ECCC provided EVE with draft reports for the 2018 BMW 530e and the 2016 Chevy Volt. A draft report for the Saturn Vue has been completed and is undergoing review as of 10 January 2020. A draft report for the Prius Prime is awaiting completion.

118. Throughout the test program, ECCC encountered difficulty obtaining R85 engine test results applicable to the vehicles tested. R85 results were finally obtained for the Toyota Prius Prime at the beginning of January 2020. ECCC has been in contact with representatives from BMW but has to date been unable to acquire R85 results for that vehicle. Because the Chevy Volt and the Saturn Vue are not EU-spec vehicles, and because the motivation for manufacturers to cooperate with this validation effort has been limited, ECCC was unable to acquire R85 data for these vehicles. For these reasons, a comparison of the results obtained by TP1 and TP2 is not possible at this time, because TP1 requires R85 data.

119. As for TP2 results, ECCC found that the torque and speed measurement devices gave inconsistent results and in some cases malfunctioned. There is significant doubt as to whether the TP2 results are valid due to these difficulties.

120. JRC has continued its effort to procure instrumentation and conduct tests, with some testing now able to be performed in mid-January 2020, and additional testing expected in a near time frame.

121. Analysis of the ECCC validation results continues. In general, the validation exercise has revealed valuable recommendations regarding the practicability of the procedure and recommendations for improving the procedure. However, firm conclusions regarding the agreement of TP1 and TP2 cannot be drawn from this testing.

~~117.122.~~ Therefore, as of January 2020, the second phase of the validation program has been able to offer only limited information regarding the test procedure, and as a result, additional revisions to the draft GTR have been very limited since the drafting group meeting in Brussels in October 2019. The latest version is being circulated at EVE 33 on January 13, 2020 and will benefit from additional attention by the drafting group on that day.

~~118.123.~~ [present conclusions and finalized changes to procedure, to be agreed upon in October 2019 in Brussels]

E. Technical Rationale and justification

E.1 Primary differences between ISO 20762 and this GTR

E.1.1 Measurement accuracies aligned with GTR No. 15

~~119.124.~~ The original motivation for the test procedure was for the determination of hybrid system power for the purpose of classification and downscaling for WLTP. Where the requirements as stated under ISO 20762 varied from GTR No. 15, they were aligned with GTR No. 15 as seen in Section II.5.2 of this GTR and summarized in Table 1 below.

Table 1. Differences in required measurement accuracies

Measurement item	ISO 20762	GTR No. 15 and this GTR
Atmospheric pressure	±100 Pa	±300 Pa
Electrical voltage	±0.5 %	±0.3 per cent FSD or ±1 per cent of reading
Electrical current	±0.5 %	±0.3 per cent FSD or ±1 per cent of reading
Room temperature	±2 °C	±1 °C
Chassis dynamometer roller speed	±0.5 km/h or ±1 %, whichever is greater	±0.2 km/h

E.1.2 Manufacturer to provide verifiable K factor(s)

~~120.125.~~ ISO 20762 allows for K factors to be provided by the manufacturer, but also provided default K factors that could be used if needed. The EVE IWG found that default K factors may not be equally accurate for all vehicles and could contribute to variation between TP1 and TP2.

~~121.126.~~ Unlike ISO 20762, this GTR will usually be applied in the context of type approval or certification. In this context, it is likely that there will be sufficient manufacturer cooperation to prevent the need to assume a default K factor.

~~122.127.~~ This GTR therefore requires the manufacturer to provide verifiable K factor(s) in all cases, as described at Section II.6.1.1.2. Determination and verification of the provided factor can be performed by applicable test standards or other methods as described in that section.

E.1.3 TP2 to utilize torque and speed sensors or hub dynamometer

~~123.128.~~ ISO 20762 specifies that measurement of torque and speed for TP2 may be performed by use of torque and speed sensors attached to the axle shafts or wheel hubs, or by dynamometer measurements of speed and torque delivered to the dynamometer rollers. In the latter case, losses in the tires are to be accounted for. A specific method for determining the losses is not provided.

~~124.129.~~ The IWG found that accounting for tire losses may introduce uncertainties specific to TP2. Accounting for rolling resistance requires that the rolling resistance coefficient (RRC) and the normal force on the tires both be known. RRC is not always known with high accuracy. When installed on a dynamometer, the normal force may be uncertain due to the effect of the tie

down method (usually tensioned straps or chains, or rigid restraints). Tire slippage under maximum power may be difficult to eliminate, and can add losses that are difficult to quantify.

~~125.130.~~ The GTR therefore removes the option for dynamometer roller measurements for TP2, and adds a new option to use a hub dynamometer on each powered axle as described at Section II.6.4.1 of this GTR.

E.1.4 TP1 to include measurement of fuel flow rate

~~126.131.~~ ISO 20762 requires measurement of intake manifold pressure for verification of engine power by reference to ISO 1585 test conditions. Measurement of fuel flow rate is only required if the confirmation of air fuel ratio according to ISO 1585 is necessary.

~~127.132.~~ Experts in the IWG indicated that intake manifold pressure may be insufficient to verify ISO 1585 test conditions especially considering variable atmospheric conditions. Fuel flow rate provides a more precise and additional check.

~~128.133.~~ The GTR requires collection of fuel flow rate for TP1 in all cases. To minimize burden, fuel flow rate may be collected from onboard data if its accuracy is shown to the responsible authority.

E.1.5 TP1 recommended to measure power input at each inverter if REESS powers multiple inverters

~~129.134.~~ ISO 20762 specifies that TP1 be performed with measurement of current and voltage at the REESS.

~~130.135.~~ The IWG found that this may introduce uncertainties specific to TP1, for electrified powertrains in which the current from the REESS is subsequently routed to more than one propulsion energy converter (i.e. more than one inverter/motor combination) that are deemed likely to experience significantly different electrical conversion efficiencies. In this case, the K1 factor would have to represent the combined efficiency of multiple components and would be difficult to verify because the individual power flows are not measured.

~~131.136.~~ For powertrains where the REESS current is routed to more than one propulsion energy converter, this GTR recommends that the input to each inverter be instrumented in addition to the REESS output, as described at Section II.6.4.1 of this GTR.

E.1.6 Repetition and averaging

~~132.137.~~ ISO 20762 does not include a requirement for repetition or averaging of multiple tests. In validation testing, some variation was observed between sequential tests. Korea recommended disregarding the first test result. The GTR now specifies that five repetitions be conducted and the result be based on an average of the last four repetitions.

E.1.7 Establishment of reference points for HEV architectures

~~133-138.~~ The IWG found that the clear identification of reference points for various HEV architectures, and the use of the same reference point for both TP1 and TP2, are important to the expectation that TP1 and TP2 should deliver the same result. This GTR establishes reference points for common HEV architectures (see Annex 1 of this GTR) and provides a clear definition of “reference point” (see Section II.3.5) to assist with the identification of valid reference points for other architectures.

E.1.8 Applicability of TP1 or TP2 determined by power flows

~~134-139.~~ ISO 20762 does not limit application of TP1 or TP2 to specific powertrain types.

~~135-140.~~ The IWG found that the flow of power through different electrified powertrain architectures can pose uncertainties for the equitable application of TP1 or TP2 using the specified reference points and measurement points..

~~136-141.~~ The GTR therefore includes a decision tree to determine the applicability of TP1 and TP2 based on power flow through the drivetrain as described in Section II.6.1.1.3 of this GTR.

~~137-142.~~ If the input to each inverter cannot be readily instrumented, draft text has been added at Section II.6.4.1 to indicate that the manufacturer may still perform TP1 by providing the authority with an accurate K1 factor representing the combined efficiency under the maximum power condition, supported by data representing the power flow to each inverter under the maximum power condition, or by assuring that the electrical conversion efficiency of each path is the same.

E.1.9 Manufacturer to provide hybrid power flow description

~~138-143.~~ The IWG found that some electrified powertrains support complex power flows. The specific flow of power that takes place under the maximum power condition is not always clear. This GTR adds a specific requirement for the manufacturer to provide a hybrid power flow description as described in Section II.6.1.1.1 of the GTR. The description shall also specify recommended measurement points, reference points, and K factor(s) where applicable. The description is intended to provide the authority with concrete information that may be used to determine the applicability of TP1 and TP2 and to assist the authority or third parties with validation and verification.

E.1.10 All-wheel drive vehicles to account for each axle independently

~~139-144.~~ ISO 20762 does not distinguish between differently powered axles. The GTR adds a specific provision that if a vehicle has two powered axles, each axle shall be tested independently and simultaneously on a 4wd chassis dynamometer or two hub dynamometers, and each may apply a different TP if desired. See proposed text at Section II.6.1.

E.1.11 Addition of suggested validation criteria

~~140.145.~~ This draft GTR proposes steps that might be taken to validate the results of the procedure. Proposed text at Section II.6.10 would (a) require that the TP sustained power result not be smaller than the power measured at the dynamometer rollers, and (b) describe how to compute an implied drivetrain efficiency using the TP sustained power result and observed dynamometer roller power, the result of which should be greater than 1. These validation steps would add the requirement to collect dynamometer roller power as described at the end of Section II.6.4.1.

~~141.146.~~ [Possible addition to be described in Appendix: Authority may collect data for both TPs and solve for missing K, and show that both K1 and K2 are reasonable for the powertrain, and both are less than 1]

E.1.12 New terms defined

~~142.147.~~ Definitions have been proposed for several new terms related to system power determination. See Section II.3.5.

~~E.1.13~~ [any other differences]

~~143.148.~~ [add text]

~~E.1.14~~ [any other differences]

~~144.149.~~ [add text]

~~E.1.15~~ [any other differences]

~~145.150.~~ [add text]

E.2 Recommendations for use of the GTR

[List any recommendations or caveats for use of the procedures, if applicable]

~~146.151.~~ [add text]

~~147.152.~~ [add text]

E.3 Future development of the GTR

[list any known outstanding issues or weaknesses, anticipated areas for future development]

~~148.153.~~ At this time, this GTR specifies a reference method but not a candidate method. A candidate method, which would not require dynamometer testing but instead would be based on the results of component tests, would allow a vehicle power rating to be determined at potentially a lower expense. Future development and validation of a candidate method remains a possibility for future work.

F. Technical feasibility, anticipated costs and benefits

~~149.154.~~ The specification of a test procedure for power determination will remove significant uncertainty that manufacturers now face in communicating the power level of electrified vehicles both to the public and to regulating authorities.

~~150.155.~~ Initially the adoption of the procedure may bear some costs for vehicle manufacturers, technical services and authorities, at least considered on a local scale, since some test equipment and procedures may have to be upgraded. However, these costs should be limited since such upgrades are done regularly as adaptations to the technical progress. Related costs would have to be quantified on a regional level since they largely depend on the local conditions.

DRAFT – for discussion EVE33

II. Text of the global technical regulation

1. Purpose

This Global Technical Regulation provides a worldwide harmonized method to determine a system power rating of electrified light-duty vehicles in a repeatable and reproducible manner and that is comparable to traditional measures of system power applicable to conventional vehicles.

2. Scope and application

This Global Technical Regulation applies to vehicles that meet all of the following criteria: (a) are hybrid electric vehicles, or are pure electric vehicles that have more than one electric machine for propulsion, and (b) are classified in category 1-1, or are classified in category 1-2 or 2 and having a technically permissible maximum laden mass not exceeding 3,500 kg, and (c) if a hybrid electric vehicle, at least one electric machine contributes to propulsion of the vehicle under the maximum power condition.

This Global Technical Regulation does not apply to fuel cell vehicles.

When determined according to the requirements of this GTR, the resulting vehicle system power rating may be considered as comparable to the power rating traditionally assigned to conventional vehicles, which is the power rating of the internal combustion engine.

The following document(s) are referenced in such a way that some or all of their content constitutes requirements of this document. The latest edition of the referenced document(s) (including any amendments) applies:

ISO 1585:1992, *Road vehicles – engine test code – Net power*

UN Regulation No. 85 — Uniform provisions concerning the approval of internal combustion engines or electric drive trains intended for the propulsion of motor vehicles of categories M and N with regard to the measurement of net power and the maximum 30 minutes power of electric drive trains

3. Definitions

The following definitions shall apply in this Global Technical Regulation. For any terms not herein defined, the definition set out in Global Technical Regulation No. 15 shall apply.

3.1 Road load and dynamometer setting

"Technically permissible maximum laden mass" means the maximum mass allocated to a vehicle on the basis of its construction features and its design performances.

“*Fixed speed mode*” means the operating mode of the dynamometer in which the dynamometer absorbs the power output of the vehicle so as to maintain the vehicle at a fixed roller speed.

“*Road load mode*” means the operating mode of the dynamometer in which the dynamometer exerts on the vehicle a force equivalent to the force exerted on the vehicle while driving on a road.

3.2 Powertrain

“*Powertrain*” means the total combination in a vehicle of propulsion energy storage system(s), propulsion energy converter(s) and the drivetrain(s) providing the mechanical energy at the wheels for the purpose of vehicle propulsion, plus peripheral devices.

“*Peripheral devices*” means energy consuming, converting, storing or supplying devices, where the energy is not primarily used for the purpose of vehicle propulsion, or other parts, systems and control units, which are essential to the operation of the powertrain.

“*Auxiliary devices*” means energy consuming, converting, storing or supplying non-peripheral devices or systems which are installed in the vehicle for purposes other than the propulsion of the vehicle and are therefore not considered to be part of the powertrain.

“*Drivetrain*” means the connected elements of the powertrain for transmission of the mechanical energy between the propulsion energy converter(s) and the wheels.

3.3 Pure electric, pure ICE, hybrid electric, fuel cell and alternatively-fuelled vehicles

“*Energy converter*” means a system where the form of energy output is different from the form of energy input.

“*Propulsion energy converter*” means an energy converter of the powertrain which is not a peripheral device whose output energy is used directly or indirectly for the purpose of vehicle propulsion.

“*Charge-depleting operating condition*” means an operating condition in which the energy stored in the REESS may fluctuate but decreases on average while the vehicle is driven until transition to charge-sustaining operation.

“*Charge-sustaining operating condition*” means an operating condition in which the energy stored in the REESS may fluctuate but, on average, is maintained at a neutral charging balance level while the vehicle is driven.

“*Category of propulsion energy converter*” means (i) an internal combustion engine, or (ii) an electric machine, or (iii) a fuel cell.

“*Energy storage system*” means a system which stores energy and releases it in the same form as was input.

“*Propulsion energy storage system*” means an energy storage system of the powertrain which is not a peripheral device and whose output energy is used directly or indirectly for the purpose of vehicle propulsion.

“*Category of propulsion energy storage system*” means (i) a fuel storage system, or (ii) a rechargeable electric energy storage system, or (iii) a rechargeable mechanical energy storage system.

"*Form of energy*" means (i) electrical energy, or (ii) mechanical energy, or (iii) chemical energy (including fuels).

"*Fuel storage system*" means a propulsion energy storage system that stores chemical energy as liquid or gaseous fuel.

"*On-board charger*" means the electric power converter between the traction REESS and the vehicle's recharging socket.

"*Electric machine*" means an energy converter transforming between electrical and mechanical energy.

"*Off-vehicle charging hybrid electric vehicle (OVC-HEV)*" means a hybrid electric vehicle that can be charged from an external source.

"*Not off-vehicle charging hybrid electric vehicle (NOVC-HEV)*" means a hybrid electric vehicle that cannot be charged from an external source.

"*Hybrid vehicle*" means a vehicle equipped with a powertrain containing at least two different categories of propulsion energy converters and at least two different categories of propulsion energy storage systems.

"*Hybrid electric vehicle*" means a hybrid vehicle equipped with a powertrain containing at least one electric motor or electric motor-generator and at least one internal combustion engine as propulsion energy converter.

"*Pure electric vehicle*" means a vehicle equipped with a powertrain containing exclusively electric machines as propulsion energy converters and exclusively rechargeable electric energy storage systems as propulsion energy storage systems.

"*Rechargeable electric energy storage system (REESS)*" means the system that provides electric energy for electrical propulsion. A battery whose primary use is to supply power for starting the engine and/or lighting and/or other vehicle auxiliaries systems is not considered as a REESS. The REESS may include the necessary ancillary systems for physical support, thermal management, electronic controls and casing.

"*Charge depleting operating condition*" means an operating condition in which the energy stored in the REESS may fluctuate but decreases on average while the vehicle is driven until transition to charge-sustaining operation.

"*Charge sustaining operating condition*" means an operating condition in which the energy stored in the REESS may fluctuate but, on average, is maintained at a neutral charging balance level while the vehicle is driven.

"*State of charge (SOC)*" means the available electrical charge in a REESS expressed as a percentage of its rated capacity.

3.4 General

"*Driver-selectable mode*" means a distinct driver-selectable condition which could affect emissions, or fuel and/or energy consumption.

"*Predominant mode*" for the purpose of this UN GTR means a single driver-selectable mode that is always selected when the vehicle is switched on, regardless of the driver-selectable mode in operation when the vehicle was previously shut down, and which cannot be redefined to another mode. After

the vehicle is switched on, the predominant mode can only be switched to another driver-selectable mode by an intentional action of the driver.

3.5 System power determination

“*Test procedure 1 (TP1)*” means a test procedure, defined herein, for determining system power via measured REESS power and determined ICE power.

“*Test procedure 2 (TP2)*” means a test procedure, defined herein, for determining system power via axle/wheel torque and speed measurement.

“*Power determination reference point*” means a point in the mechanical power flow of a powertrain where at least a portion of the power transmitted under the maximum power condition is counted toward the vehicle system power rating.

“*Speed of maximum power*” means the fixed speed setting of the dynamometer at which a maximum accelerator pedal command, given for a period of at least ten seconds, delivers the greatest peak power to the dynamometer rollers.

“*Maximum power condition*” means the condition in which the vehicle is operating on a dynamometer, the dynamometer is operating in fixed speed mode set to the speed of maximum power, and the maximum accelerator pedal command is given for a period of at least ten seconds.

“*Vehicle system power rating*” means the total ~~mechanical~~ power transmitted through the power determination reference point(s) as determined by TP1 or TP2.

“*K1 factor*” means the electrical energy conversion efficiency between the REESS and a power determination reference point, applicable to the operating condition that is observed under the maximum power condition.

“*K2 factor*” means the mechanical energy conversion efficiency between a power determination reference point and the wheel hubs or axle shafts, applicable to the operating condition that is observed under the maximum power condition.

“*Mechanical energy path*” means a distinct parallel path within a drivetrain that conducts a portion of the total mechanical energy passing through the drivetrain.

4. Abbreviations

4.1 General abbreviations

AWD	all wheel drive
HEV	hybrid-electric vehicle
ICE	internal combustion engine
ICEV	internal combustion engine vehicle
ISO	International Organization for Standardization

REESS	rechargeable electric energy storage system
SOC	state of charge
UN	United Nations
TP1	Test procedure 1
TP2	Test procedure 2

5. Test conditions

5.1 Test instrumentation

5.1.1 Chassis dynamometer

The power absorption capacity of the chassis dynamometer in fixed speed control mode shall be sufficient for the maximum power of the vehicle. Due to the short duration of maximum power under the test procedure (approximately 10 seconds), a short duration power rating of the chassis dynamometer may be applicable to this requirement with approval of the responsible authority.

5.1.2 Test room

The test cell shall have a temperature set point of 25 °C. The tolerance of the actual value shall be within ± 5 °C.

Atmospheric pressure in the test cell shall be between 80kPa and 110 kPa.

5.1.3 Cooling fan

A current of air of variable speed shall be blown towards the vehicle. The set point of the linear velocity of the air at the blower outlet shall be equal to the corresponding dynamometer speed above measurement speeds of 5 km/h. The deviation of the linear velocity of the air at the blower outlet shall remain within ± 5 km/h or ± 10 per cent of the corresponding measurement speed, whichever is greater.

5.1.4 Soak area

The soak area shall have a temperature set point of 23 °C and the tolerance of the actual value shall be within ± 3 °C on a 5-minute running arithmetic average and shall not show a systematic deviation from the set point. The temperature shall be measured continuously at a minimum frequency of 0.033 Hz (every 30 s).

5.2 Measurement

5.2.1 Measurement items and accuracy

Measurement devices shall be of certified accuracy as shown in Table 2 traceable to an approved regional or international standard.

Table 2 — Measurement items and required accuracy

Item	Units	Accuracy	Remarks
Engine speed	min ⁻¹	± 10 min ⁻¹ or ± 0.5% of measured value	Whichever is greater
Intake manifold pressure	Pa	± 50 Pa	Intake manifold pressure means inlet depression as used in ISO1585:1992.
Atmospheric pressure	Pa	±0.3 kPa, with a measurement frequency of at least 0.1 Hz	
Fuel flow rate	g/s	± 3 %	As an alternative to the external measurement of the fuel flow rate, the manufacturer may use the onboard data if its accuracy is demonstrated to the responsible authority.
Electrical voltage	V	±0.3 per cent FSD or ±1 per cent of reading	Whichever is greater. Resolution 0.1 V. As an alternative to the external measurement, the manufacturer may use the onboard data if its accuracy is demonstrated to the responsible authority.
Electrical current	A	±0.3 per cent FSD or ±1 per cent of reading	Whichever is greater. Current integration frequency 20 Hz or more for external measurement. Resolution 0.1 A. As an alternative to the external measurement, the manufacturer may use the onboard data if its accuracy is demonstrated to the responsible authority.
Electrical energy	Wh	±1 per cent	Resolution 0.001 kWh. Equipment: static meter for active energy. AC watt-hour meter, Class 1 according to IEC 62053-21 or equivalent
Room temperature	K	±1 °C, with a measurement frequency of at least 0.1 Hz	
Chassis dynamometer roller speed	km/h	The roller speeds shall be controlled with an accuracy of ±0.2 km/h	

Time	s	± 10 ms; min. precision and resolution: 10 ms	
Axle/wheel rotational speed	s ⁻¹	± 0.05 s ⁻¹ or ± 1 %, whichever is greater	
Axle/wheel torque	Nm	± 6 Nm or ± 0.5 % of the maximum measured total torque, whichever is greater, for the whole vehicle, with a measurement frequency of at least 10 Hz	
Accelerator pedal command	percent	± 1 percent	

5.2.2 Measurement frequency

All the items in Table 2 of 5.2.1, except atmospheric pressure and room temperature, shall be measured and recorded at a frequency equal to or greater than 10 Hz.

The items atmospheric pressure and room temperature shall be at least recorded as single measurement activity at start of vehicle operation (see 6.8.4) and after end of vehicle running (see 6.8.7).

The air temperature shall be measured at the test cell's cooling fan outlet at a minimum frequency of 0.1 Hz. Atmospheric pressure shall be measurable with a resolution of 0.1 kPa.

6. Test procedure

6.1 General

The following test procedure determines a vehicle system power rating for a hybrid electric vehicle, or for a pure electric vehicle with more than one propulsion energy converter.

Two test procedures are described herein. Both test procedures define a specific set of measurements to be performed at specific measurement points and specify calculations to convert these measurements to the vehicle system power rating.

Test procedure 1 (TP1) is based on measured REESS power, estimated ICE power, and estimated electrical conversion efficiency.

Test procedure 2 (TP2) is based on measured torque and speed at the drive shaft(s) or wheel(s) and estimated mechanical conversion efficiency.

TP1 and TP2 are intended to be technically equivalent methods for determining a vehicle system power rating from available measurements. TP1 and TP2 are distinguished by the specific instrumentation, measurements, other inputs, and calculations necessary to determine the vehicle system power rating.

Each powered axle that provides propulsion under the maximum power condition shall be tested by chassis dynamometer or hub dynamometer. Vehicles ~~with that are powered by~~ two powered axles under the maximum power condition shall be tested by four-wheel-drive chassis dynamometer, or each powered axle shall be tested simultaneously by hub dynamometer.

6.1.1 Required information

The manufacturer shall provide the following information required to conduct either test procedure

6.1.1.1 Hybrid power flow description

The manufacturer shall provide a hybrid power flow description that traces the energy flow through all of the mechanical and electrical systems that are in operation under the maximum power condition.

The description shall trace in full the energy flow paths and energy conversions beginning at each of the propulsion energy storage systems to each powered axle and each non-propulsion auxiliary device that is powered by the REESS. The description shall also indicate the power determination reference points applicable to the vehicle, the measurement points according to TP1 or TP2, and the components to which applicable K factors apply.

6.1.1.2 Energy conversion factors (“K factors”)

Where TP1 is to be performed, the manufacturer shall provide the energy conversion efficiency (K1) between each measurement point and the respective mechanical power output of each propulsion energy converter that contributes propulsion torque during the maximum power condition.

In determining or verifying a K1 factor, the electrical conversion efficiency of the inverter and electric machine or their combinations shall be determined by an applicable test standard such as ISO 21782, SAE J2907, or equivalent.

Where TP2 is to be performed, the manufacturer shall provide, for each powered axle, the energy conversion efficiency (K2) between the measurement point and the respective mechanical power output of each propulsion energy converter that contributes propulsion torque to that axle during the maximum power condition.

In determining or verifying a K2 factor, the mechanical conversion efficiency of drivetrain components or their combinations shall be determined by dividing the measured output power by the measured input power.

6.1.1.3 Speed of maximum power

The speed of maximum power (as defined in 3.5) shall be determined by the procedure specified in 6.11, either by the manufacturer or the responsible authority.

6.1.2 Test procedure options

~~The responsible authority shall use the following considerations to determine whether the choice of TP1 or TP2 for a given powered axle may be left to the choice of the manufacturer, or if TP1 or TP2 is specifically required. Each powered axle shall be considered separately. The responsible authority shall use the following considerations to determine applicability of TP1 and TP2 to each powered axle of the test vehicle. Where both TP1 and TP2 are applicable, the choice may be made by the manufacturer.~~

6.1.2.1 Applicability of TP1

In some cases, additional instrumentation may be required. Refer to the hybrid power flow description.

(A) If the electrical current from each REESS powers a single electric machine, TP1 requires measurement of the current and voltage at each REESS.

(B) Otherwise,

(i) TP1 requires measurement of the current and voltage at the input to each inverter that is powered by the REESS; or,

(ii) The manufacturer may provide an accurate K1 factor representing the combined efficiency under the maximum power condition, supported by data representing the power flow to each inverter under the maximum power condition, or

(iii) The manufacturer shall provide assurance that the electrical conversion efficiency on each branch of the path is the same, or

(iv) The manufacturer shall provide for inverter input current and voltage to be provided via onboard data, if its accuracy is demonstrated to the responsible authority.

6.1.2.2 Applicability of TP2

~~When conducted for type approval, the vehicle system power rating may be determined by TP1 or TP2 at the discretion of the manufacturer, subject to the availability of the necessary measurements, instrumentation, and other inputs for the vehicle to be approved, as well as the following requirements.~~

Refer to the hybrid power flow description. For each powered axle:

(A) If the torque to the axle originates from a single torque-producing component, then the power to the axle may be determined by ~~either TP1 or~~ TP2; otherwise,

(B) If the torque to the axle is a combined torque consisting of torque contributions from more than one torque-producing component, then:

(i) If all of the individual torque contributions are transmitted to the axle via the same mechanical path, the power to the axle may be determined by ~~either TP1 or~~ TP2; otherwise,

~~(ii) If any of the individual torque contributions are transmitted to the axle via different mechanical paths, then the power to that axle shall be determined either by~~ may not be determined by TP2.:

~~(1) TP1, or~~

- ~~(2) TP2, with the additional requirements that:~~
- ~~(a) each individual torque contribution to the axle is determined by means of appropriate instrumentation, and~~
- ~~(b) an accurate factor is provided for the mechanical efficiency of each mechanical path by which each individual torque contribution is transmitted to the axle.~~

The total hybrid system power is the sum of the power from each powered axle.

When reported for type approval, the vehicle system power rating that is determined by use of this GTR shall be identified as having been determined by either TP1 or TP2.

6.2 Preparation of dynamometer

6.2.1 Roller

Chassis dynamometer roller(s) shall be clean, dry and free from foreign material which can cause tire slippage.

6.2.2 Tire slippage

Measures shall be taken to stabilize tire slippage that may occur during maximum power. The use of ~~and amount of~~ any additional weight placed in or on the vehicle, or the use of other measures for this purpose, shall be recorded.

6.2.3 Dynamometer warm-up

The dynamometer shall be warmed up in accordance with the dynamometer manufacturer's recommendations, or as appropriate, so that the frictional losses of the dynamometer may be stabilized.

6.2.4 Dynamometer control

For vehicle conditioning (6.8.2), the dynamometer shall be controlled in road load mode. For the power test (6.8.5), the dynamometer shall be controlled in fixed speed mode.

6.3 Preparation of vehicle

The front and rear tires shall be inflated to the lower limit of the tire pressure range for the respective axle for the selected tire at the coastdown test mass, as specified by the vehicle manufacturer. The vehicle lubricants and levels specified by the manufacturer shall be used.

Fuel shall be the same fuel that was used for certification of the engine. For example, the fuel specified in UN ECE Regulation No. 85 shall be used for vehicles with an engine certified under that regulation..

6.4 Measurements

6.4.1 Measurement points

The test vehicle shall be instrumented with measurement devices for measuring certain input values for the power calculation, depending on whether TP1 or TP2 is performed.

For TP1, measurement devices shall be used to measure ICE speed, intake manifold pressure, REESS current, REESS voltage, and fuel flow rate.

~~If the hybrid power flow description indicates that the electrical power from the REESS flows to more than inverter to power more than one propulsion energy converter, then measurement devices shall also be used to measure the current and voltage at the input to each inverter. Alternatively, the manufacturer may (a) provide an accurate K1 factor representing the combined efficiency under the maximum power condition, supported by data representing the power flow to each inverter under the maximum power condition, or (b) provide assurance that the electrical conversion efficiency on each branch of the path is the same, or (c) provide for inverter input current and voltage to be provided via onboard data, if its accuracy is demonstrated to the responsible authority.~~

Optionally, current and voltage of the DC/DC converter may be measured to allow calculation of power to DC/DC converter for 12-volt auxiliaries. In addition, current and voltage of each 12-volt auxiliary device may be measured to allow calculation of power to auxiliaries.

~~If the hybrid power flow description indicates that any auxiliaries are directly powered by the REESS, measurement devices shall be used to measure the current and voltage to these auxiliaries during the power test, the power consumed shall be quantified and accounted for.~~

For TP2, measurement devices shall be used to measure wheel torque and rotational speed. If the ICE power needs to be corrected according to the provisions of 6.9.3.2, the measurement requirements for TP1 with regard to current and voltage shall also apply. Wheel torque and rotational speed measurement may be provided either by means of a hub dynamometer or by means of appropriate, calibrated measurement device(s) for torque and rotational speed of the gearbox output shaft(s) or the driven wheel(s).

As an alternative to use of measurement devices, use of on-board measurement data is permissible if the accuracy of these data is demonstrated to the responsible authority to meet the minimum requirements for accuracy described in Table 2 of 5.2.1.

If a powered axle delivers power to the wheels through a differential, it is sufficient to instrument and collect data from only one of the two drive shafts or wheels. In this case, the measured torque at a drive shaft or wheel shall be multiplied by 2 in order to get the total torque per driven axle.

For both TP1 and TP2, for the purpose of internal validation (see 6.10), the power delivered by the vehicle to the dynamometer rollers during the maximum power condition shall be recorded.

6.4.2 Preparation of measurement devices

The measurement devices shall be installed at suitable position(s) and warmed up as appropriate.

6.5 Initial charge of REESS for OVC-HEV

For OVC-HEVs, prior to or during vehicle soak (6.6), the REESS shall be charged to an initial SOC at which maximum system power is obtained. The manufacturer may specify the initial SOC at which maximum system power is obtained.

The initial charge of the REESS shall be conducted at an ambient temperature of 20 ± 10 °C.

The REESS shall be charged to the initial SOC in accordance with the procedure specified by the manufacturer for normal operation until the charging process is normally terminated.

The SOC shall be confirmed by a method provided by the manufacturer.

6.6 Vehicle soak

The vehicle shall be soaked in the soak area for a minimum of 6 hours and a maximum of 36 hours with the engine compartment cover opened or closed. The manufacturer may recommend a specific soak time or range of soak times within the range of 6 to 36 hours if necessary to ensure temperature stabilization of the high voltage battery. The soak area conditions during soak shall be as specified in 5.1.4.

6.7 Vehicle installation

The vehicle shall be installed on the dynamometer in accordance with the dynamometer manufacturer's recommendation, or regional or national regulations.

Auxiliary devices shall be switched off or deactivated during dynamometer operation unless their operation is required by regional legislation.

If auxiliaries except DC/DC converter cannot be turned off, then the power to 12V auxiliaries ($P_{\text{auxiliary}}$ as defined later in this regulation) shall either be (a) measured and calculated, or (b) the specified default value may be used, and finally subtracted from the measured REESS power.

If necessary to operate properly on the dynamometer, the vehicle's dynamometer operation mode, shall be activated by using the manufacturer's instruction (e.g. using vehicle steering wheel buttons in a special sequence, using the manufacturer's workshop tester, removing a fuse).

The manufacturer shall provide the responsible authority a list of the deactivated devices and justification for the deactivation. The dynamometer operation mode shall be approved by the responsible authority and the use of a dynamometer operation mode shall be recorded.

The vehicle's dynamometer operation mode shall not activate, modulate, delay or deactivate the operation of any part that affects the emissions and fuel consumption under the test conditions. Any device that affects the operation on a dynamometer shall be set to ensure a proper operation.

The test cell temperature at the start of the test shall be $25\text{ °C} \pm 3\text{ °C}$. The engine oil temperature and coolant temperature, if any, shall be within $\pm 2\text{ °C}$ of the soak room set point of 23 °C .

6.8 Test sequence

6.8.1 General

The test shall be carried out in accordance with 6.8.2 to 6.8.7, and 6.9 to 6.11 (see Figure 16). The test shall be stopped immediately if warning indicator(s) with regard to the powertrain turns on.

Note: Warnings are coolant temperature and engine check lamp, for example.

Prior to testing, the vehicle shall have attained a run-in mileage as required by GTR No. 15.

The following operational metrics, if present, shall be monitored throughout the test: (a) engine coolant temperature, (b) battery temperature (as indicated by temperature of battery cells, modules, or pack, as available), (c) transmission or gearbox oil temperature, (d) battery SOC, (e) electric machine temperature (as indicated by temperature of stator, rotor, or cooling fluid, as available). The manufacturer shall specify the normal operating range for each operational metric.

6.8.2 Vehicle conditioning

In order to condition the vehicle, operate the vehicle for at least one Class 3a or 3b WLTC cycle. If the vehicle cannot meet the trace, operate the vehicle at best effort or according to manufacturer recommendation. Condition the vehicle and monitor the temperature-related operational metrics until the normal operating temperature ranges specified by the manufacturer have been reached.

~~it shall run at the speed of 60 km/h at the vehicle road load for at least 20 minutes. Alternatively, the vehicle manufacturer may specify a longer period.~~

At the end of ~~the first conditioning cycle~~, the operational metrics (see 6.8.1) shall be recorded.

If a measurement loop is being performed at various fixed dynamometer speeds according to the provisions of 6.11, the vehicle conditioning time in the second and subsequent loops may be shorter ~~than 20 minutes~~ according to the vehicle manufacturer's recommendation or if the temperatures of monitored components are ~~not higher than recorded at the end of the first conditioning cycle~~ within the specified operating rangest.

6.8.3 REESS adjustment

During vehicle conditioning according to 6.8.2, the SOC shall be monitored. For OVC-HEVs, the SOC shall be adjusted at the end of vehicle conditioning to the SOC at which maximum system power is obtained as recommended by

the manufacturer. REESS adjustment also applies to repetition of observations as directed in 6.8.6.

REESS adjustment shall be performed by use of light regenerative braking, or by allowing the vehicle to coast, while the dynamometer is operated in fixed speed mode. The charge rate by either method shall be monitored and shall be limited as recommended by the manufacturer to avoid undue heating of the battery or derating of the battery power.

6.8.4 Vehicle operation

The measurement devices shall start collecting data.

Note: for vehicles that have driver-selectable modes, the vehicle system power rating that is determined by this procedure may depend on which mode is active during the test. If the vehicle has driver-selectable modes, select the mode for which a vehicle system power rating is desired. ~~For example, to determine the vehicle system power rating in the predominant mode as defined by GTR No. 15, refer to the provisions in Annex 8 Appendix 6 of GTR No. 15 to identify the predominant mode. For OVC HEVs, the predominant mode may also depend on the operating condition (for example, charge depleting or charge sustaining operating condition). The manufacturer may be consulted to identify the operating condition in which the corresponding predominant mode delivers the highest power.~~

The driver-selectable mode under which the test is performed shall be recorded.

Place the dynamometer in fixed speed mode.

If the speed of maximum power is known, then set the dynamometer to that fixed speed.

Otherwise, identify the speed of maximum power by carrying out a sufficient number of tests at varied fixed speeds of the dynamometer (see 6.11).

6.8.5 Power test

The maximum accelerator pedal command shall be given by either the pedal position or by vehicle communication network for a duration of at least 10 s.

The maximum accelerator command shall be given as rapidly as possible. If necessary in order to elicit maximum power delivery, it is permissible to vary the accelerator pedal command as recommended by the manufacturer prior to the maximum accelerator pedal command.

If the gearbox has user-selectable gears, the gear shall be selected as for ordinary driving.

6.8.6 Repetition of power test

The power test of 6.8.5 shall be repeated for a total of five repetitions as shown in Figure 16. Prior to the second and subsequent repetitions, SOC shall be adjusted according to 6.8.3. The temperature-related operational metrics listed

in 6.8.1 shall be monitored during all repetitions and seen to remain within the normal operating range specified by the manufacturer pursuant to 6.8.2.

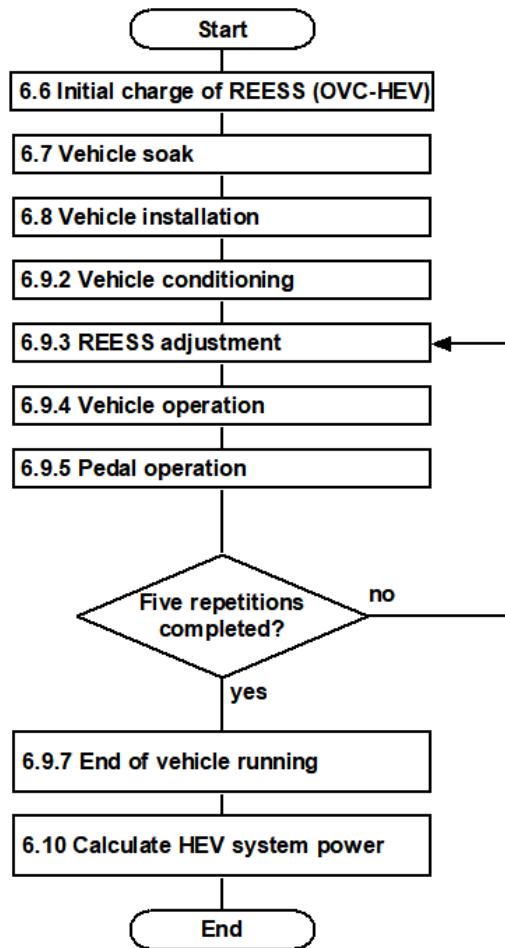

Figure 16 — Test sequence

6.8.7 End of vehicle running

After the measurements are complete, the vehicle and measurement devices shall be stopped.

6.9 Calculation of vehicle system power rating

6.9.1 General

For each of the 2nd through 5th repetitions according to 6.8.6, time series data obtained from 6.8 shall be analyzed to determine power. The vehicle system power rating that is reported as the result of the test procedure shall be an average of the individual results of the four analyzed repetitions.

Regardless of TP1 or TP2, two power calculations shall be performed:

- 1) a 2-second “peak” power that applies a 2-second moving average filter for the 10-second measurement time; and

2) a “sustained” power that defines the average power within the measurement time window from 8 s to 10 s, or if a gear shift occurs before 10 s, then a time window consisting of the last two seconds before the gear shift.

The 10-second measurement time window begins when the accelerator pedal command reaches maximum as indicated by the accelerator pedal command measurement.

Note: In case of ICE power corrections according to ISO 1585, it is permissible to ask the vehicle manufacturer if necessary. It is possible that HEV power trains possess their own power compensation.

6.9.2 Calculation for TP1

The vehicle system power rating is calculated as the sum of ICE power and converted REESS power:

$$\begin{aligned} \text{HEV system power [kW]} \\ = \text{ICE power [kW]} + \text{converted REESS power [kW]} \end{aligned}$$

a) ICE power [kW] shall be determined by reference to the full load power curve as a function of engine speed, applicable to the engine that is installed in the vehicle, and subject to confirmation of intake manifold pressure and fuel flow rate. The full load power curve shall be derived from the applicable engine test standard and shall be measured under steady state conditions.

For manufacturers to which engine certification by ISO 1585 or UN Regulation 85 is applicable by regulation, the applicable engine test standard is ISO 1585:1992. For other manufacturers, the applicable standard is that which is applicable by local or regional regulation. In the case that no engine test standard is applicable by regulation, the applicable standard is SAE J1349 (steady state). The engine dynamometer test fuel shall be as specified in the applicable standard.

Compare the measured intake manifold pressure and fuel flow rate to those reported in the certification results of the applicable standard at the measured engine speed.

If:

$$\begin{aligned} &|(\text{measured fuel flow rate} - \text{fuel flow rate at certification})| \\ &< (0.02)(\text{fuel flow rate at certification}) \end{aligned}$$

and

$$\begin{aligned} &|(\text{gauge pressure at test} - \text{gauge pressure at certification})| \\ &< (0.02)(\text{intake manifold pressure at certification}) \end{aligned}$$

then ICE power is the power indicated by the full load power curve at the measured engine speed.

Otherwise, conduct ISO 1585:1992 under the observed conditions using the above-measured engine speed, intake manifold pressure and fuel flow rate, or ask the vehicle manufacturer for support in determining the ICE power under the observed conditions, or conduct TP2.

b) converted REESS power [kW] shall be determined by the equation:

$$\begin{aligned} & \text{converted REESS power [kW]} \\ & = \left(\frac{U_{REESS} \times I_{REESS}}{1000} - P_{DCDC} - P_{aux} \right) \times K1 \end{aligned}$$

where

U_{REESS} is the measured REESS voltage [V]

I_{REESS} is the measured REESS current [A]

P_{DCDC} is the power to DC/DC converter for 12V auxiliaries (either 1.0kW or measured value) [kW]

P_{aux} is the power to non-12V auxiliaries (measured value) [kW]

If the power is measured, P_{DCDC} and P_{aux} are calculated as:

$$P_{DCDC} = U_{DCDC} \times I_{DCDC} / 1000$$

$$P_{aux} = U_{aux} \times I_{aux} / 1000$$

where

I_{aux} is the current to auxiliaries except DC/DC converter for 12V auxiliaries [A]

I_{DCDC} is the current to DC/DC converter for 12V auxiliaries [A]

P_{DCDC} is the power to DC/DC converter for 12V auxiliaries (1.0 kW or measured value)

P_{aux} is the power to auxiliaries except DC/DC converter for 12V auxiliaries (measured value) [kW]

U_{aux} is the voltage to auxiliaries except DC/DC converter for 12V auxiliaries [V]

U_{DCDC} is the voltage to DC/DC converter for 12V auxiliaries [V]

$K1$ is the conversion factor from electrical power to mechanical power, defined as output power of electric machine divided by input power of inverter at the operation condition of the electric machine during maximum power condition (measured value).

The measured value shall be provided by the manufacturer and is subject to verification by the responsible authority. The manufacturer shall determine the $K1$ value by [an applicable standard such as ISO 21782 or SAE J2907](#).

If the hybrid power flow description indicates that multiple electric machines contribute to propulsion of the vehicle under the maximum power condition, the current and voltage at each inverter input shall additionally be measured, and a $K1$ factor for each combination of inverter and electric machine shall be supplied. Alternatively, inverter input current and voltage may be provided via onboard data if its accuracy is demonstrated to the responsible authority.

The HEV system power is calculated by adding the total of a) and b).

6.9.3 Calculation for TP2:

6.9.3.1 Calculation

The power at the wheels is calculated by multiplying individually the measured data of each drive shaft or wheel torque with the corresponding drive shaft or wheel speed to get the individual drive shaft or wheel power values and finally by the sum of each individual drive shaft or wheel power values according to the following formulas:

$$\begin{aligned} \text{Drive shaft or wheel power [kW]} \\ &= (2\pi \times \text{drive shaft or wheel speed [s}^{-1}\text{]} \\ &\quad \times \text{drive shaft or wheel torque [Nm]})/1000 \end{aligned}$$

$$\begin{aligned} \text{HEV system power at all axles or all wheels [kW]} \\ &= \text{Sum of drive shaft or wheel power of each driven drive shaft or wheel [kW]} \end{aligned}$$

In order to calculate the vehicle system power rating, the measured power at the wheels shall be corrected by the gearbox system efficiency factor K_2 according to the following formula:

$$P_{HEV\ system} [kW] = \frac{P_{HEV\ system\ at\ wheels} [kW]}{K_2}$$

Where

$P_{HEV\ system}$ is the HEV system power [kW]

$P_{HEV\ system\ at\ wheels}$ is the HEV system power at all axles or wheels [kW]

K_2 is the gearbox system efficiency factor, supplied by the manufacturer and subject to verification by the responsible authority. In the case of multiple driven axles with different gearbox efficiencies, a K_2 factor for each gearbox shall be supplied.

[Add provisional text, in an Appendix, describing how the K_2 factor might be verified by equality check].

6.9.3.2 ICE power correction factors

Ask the manufacturer if the HEV powertrain possesses power compensation means that corrects for the effect of atmospheric and temperature conditions on the ICE portion of the total combined power (such as, for example, increasing the contribution of electric machine power to compensate for a reduction in ICE power).

If the powertrain does not possess power compensation, the ICE power portion of the vehicle system power rating/HEV system power shall be corrected according to the provision given in ISO 1585:1992 clause 6, if:

- the reference atmospheric and temperature conditions, given in ISO 1585:1992 clause 6.2.1; or
- the automatic control conditions according to ISO 1585:1992, clause 6.3 cannot be fulfilled.

If the ICE power portion needs to be corrected, follow 6.9.3.3, otherwise continue with 6.11.

6.9.3.3 Corrected vehicle system power rating for TP2

TP2 does not deliver a measured value for the ICE power portion. If a correction of the ICE power portion according to 6.9.3.2 is required, the following additional actions for TP2 are required:

— Determine in addition to the already measured torque and speed values the REESS power via DC voltage and current measurement at the REESS (see 6.4.1). Correct the measured power value at REESS with auxiliary power values, if necessary (e.g. power to DC/DC converter for 12V auxiliaries, equal to 1.0 kW or measured value) (see 6.9.2). Multiply the corrected electrical power value with the conversion factor K1 valid for the tested HEV:

$$\begin{aligned} \text{Converted REESS power [kW]} \\ &= (U_{REESS}[V] \times I_{REESS}[A] \div 1000 - P_{DCDC} [kW] \\ &\quad - P_{auxiliaries} [kW]) \times K1 \end{aligned}$$

Where

U_{REESS} is the measured REESS voltage [V]

I_{REESS} is the measured REESS current [A]

P_{DCDC} is the power to DC/DC converter for 12V auxiliaries (1.0kW or measured value) [kW]

$P_{auxiliaries}$ is the power to non-12V auxiliaries (measured value) [kW]

$K1$ is the conversion factor from electrical power to mechanical power (measured value provided by manufacturer as for TP1).

— Subtract the converted REESS power from the vehicle system power rating. The result is the measured ICE power:

$$P_{ICE} [kW] = P_{HEV\ system} - \text{converted REESS power [kW]}$$

— Correct the measured ICE power according to ISO 1585:1992:

$$P_{ICE, corrected} [kW] = P_{ICE} [kW] \times \text{Power correction factor}$$

where Power correction factor is according to ISO 1585:1992, clause 6.

— The sum of corrected ICE power and converted REESS power is the corrected vehicle system power rating:

$$\begin{aligned} P_{HEV\ system\ power, corrected} [kW] \\ &= P_{ICE, corrected} [kW] + \text{converted REESS power [kW]} \end{aligned}$$

6.10 Internal validation of vehicle system power rating

To be considered valid, the vehicle system power rating according to TP1 or TP2 shall fulfill both of the following requirements:

- (1) The average power recorded at the dynamometer rollers between the 8th and 10th second shall not exceed the uncorrected sustained power result.
- (2) The implied downstream efficiency between the reference point and the road shall not be greater than ~~unity~~ 1. Implied downstream efficiency is computed by dividing the average power recorded at the dynamometer rollers between the 8th and 10th second by the uncorrected sustained power result.

6.11 Determination of speed of maximum power

The speed of maximum power (defined at 3.5) is the maximum value in the relation between power and speed (see Figure 17), where power is the power delivered to the dynamometer rollers and speed is the speed of the vehicle operating in fixed speed mode on a dynamometer. If the vehicle manufacturer has specified the speed of maximum power, the test shall be run with the dynamometer set to ~~this~~ that vehicle speed. If verification is desired, run at slightly different speeds above and below the specified speed. If the manufacturer has not specified ~~a the vehicle~~ speed of maximum power, ~~the maximum HEV system power~~ it shall be identified by conducting the test procedure at a series of fixed vehicle speeds in order to identify the speed at which maximum power occurs.

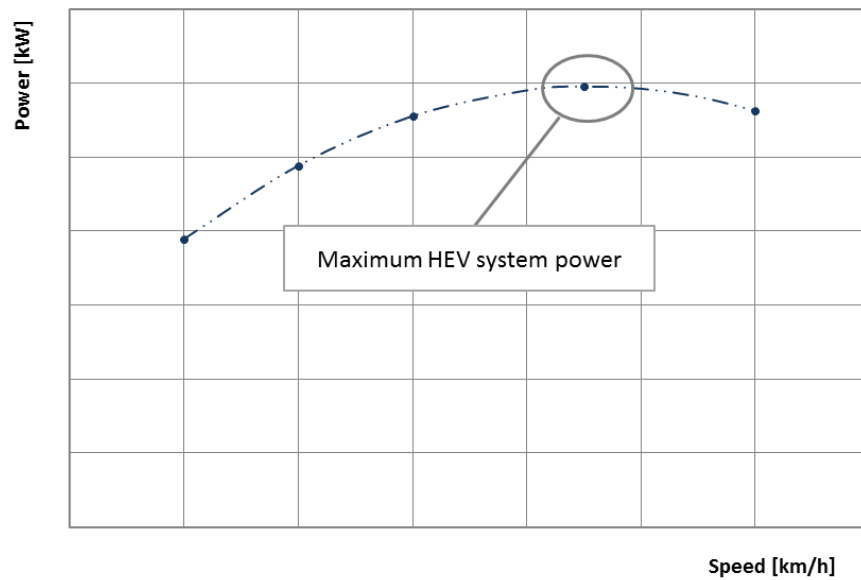

Figure 17 — Relation between power and speed

DRAFT

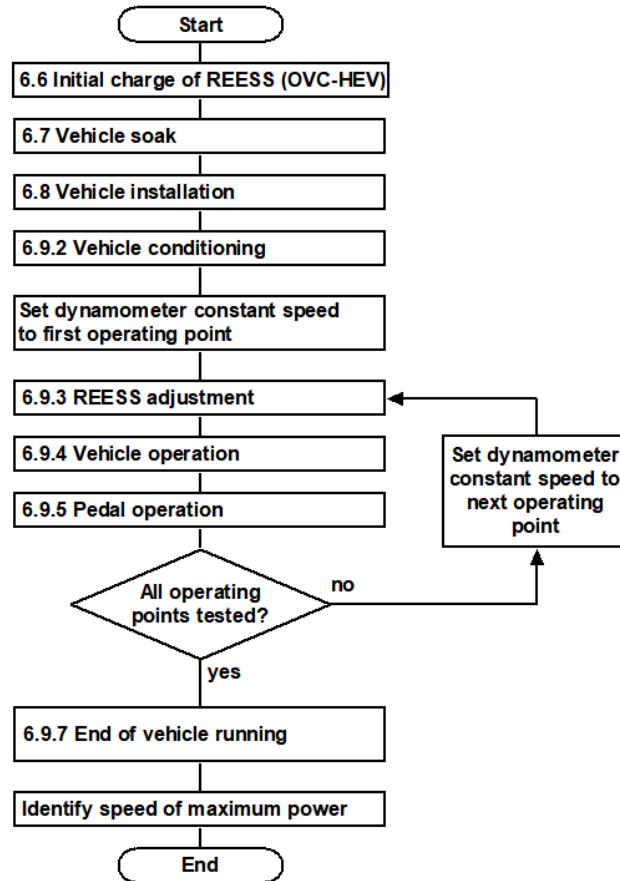

Figure 18 — Test sequence for determination of speed of maximum power

The test sequence depicted in Figure 18 shall be continued until the speed of maximum power is determined.

Then, shut down the voltage and current measurement devices and continue with clause 7.

7. Test report

7.1 General

The test report and the statement of result shall indicate which test procedure (TP1 or TP2 in 6.1) was carried out and which power calculation 1) peak power or 2) sustained power in 6.9.1 was used. Depending on whether TP1 or TP2 was carried out, the test report shall also include at least the data listed in 7.2 or 7.3, respectively. The test report shall also include the environmental data listed in 7.4 and the general vehicle data listed in 7.5.

7.2 Test report data specific to TP1

7.2.1 Calculated values based on measured data

- Vehicle system power rating [kW]
- ICE power [kW]

- Converted REESS power [kW]

7.2.2 Measured data

- ICE speed [min^{-1}]
- Intake manifold pressure [Pa]
- Fuel flow rate [g/s]
- U_{REESS} [V]
- I_{REESS} [A]
- U_{DCDC} [V] and I_{DCDC} [A] (if measured)
- Axle/wheel rotational speed [s^{-1}]
- Conversion factor from electrical power to mechanical power, K , if measured
- Accelerator pedal command [percent]

7.2.3 Assumed values

- P_{DCDC} [1.0 kW]
- Conversion factor from electrical power to mechanical power, $K1$
- List of $P_{\text{auxiliaries}}$ (power of auxiliary devices is needed for the determination of the converted REESS power)

7.3 Test report data specific to TP2

7.3.1 Calculated values based on measured data

- Vehicle system power rating [kW]
- Maximum HEV system power at axle/wheel [kW]

7.3.2 Measured data

- HEV system power at axle/wheel, measured [kW]
- Chassis dynamometer roller speed at maximum HEV system power [km/h]
- U_{REESS} [V]
- I_{REESS} [A]
- U_{DCDC} [V] and I_{DCDC} [A] (if measured)
- Axle/wheel rotational speed [s^{-1}]
- Axle/wheel torque [Nm]
- Accelerator pedal command [percent]
- Conversion factor from electrical power to mechanical power, $K1$ (if engine power correction performed)
- Gearbox system efficiency factor ($K2$)

7.3.3 Assumed values

- P_{DCDC} [1.0 kW]

7.4 Environmental data

- Atmospheric pressure [Pa]
- Room temperature [°C]

7.5 General vehicle data based on the manufacturer's information

- Vehicle name & type
- Gearbox system
- REESS system
- Nominal voltage REESS system [V]
- REESS energy [kWh]
- ICE system
- ICE displacement [cm³]
- Maximum ICE power at engine speed [kW @ min⁻¹]
- Type of electric machine
- Maximum power of the electric machine and the corresponding speed [kW @ min⁻¹]

DRAFT – for discussion EVE33

Annex 1

Identification of power determination reference points

1. General approach

1.1 Both TP1 and TP2 convert a set of specified vehicle test measurements to a vehicle system power rating that represents the mechanical power transmitted through one or more power determination reference points.

1.2 A power determination reference point is a point in an electrified powertrain as defined in Section 3.5. A given electrified powertrain may include one or more power determination reference points as necessary to account for total system power. The vehicle system power rating is the sum of the power transmitted through all of the reference points.

1.3 Power determination reference points are intended to represent points in the electrified powertrain that are most analogous to the engine output shaft in a conventional vehicle. Here, “analogous” means representing a similar basis for the accounting of power output and losses, namely, that conventional vehicles are assigned a system power rating equal to the rated power of the engine, and the losses downstream of the engine output shaft are not considered.

1.4 Identification of reference points for complex electrified powertrains can therefore be a matter of judgement and will vary depending on the specific power flow paths that are active in a given mode of the vehicle or at a given power demand. For the purpose of system power determination under this GTR, reference points shall be identified according to the requirements of this Annex.

1.5 Calculation of the vehicle system power rating under both TP1 and TP2 shall result in an estimate of the sum of the power at all of the established reference points. Both TP1 and TP2 shall reference the same established reference points for a given powertrain.

2. Identifying power determination reference points

2.1 General considerations

2.1.1 Power determination reference points represent all of the sources of the total power that is transmitted to the road during the maximum power condition. This means that they are based not only on powertrain layout but also on the state of the powertrain during a maximum power demand event. Propulsion energy converters that are not operating or are not contributing propulsion energy to the road in this state are not included.

2.2 Parallel architectures

2.2.1 The power determination reference points for parallel architectures are generally (a) the engine mechanical power output shaft and (b) the mechanical power output shaft(s) of any electric machines.

2.3 Power split architectures

2.3.1 Power split architectures often have more than one input and/or output to a complex gearbox that may include one or more planetary gearsets, and may also include a series power conversion path. The power determination reference points for power split architectures are generally (a) the engine mechanical power output shaft and (b) the mechanical power output shaft(s) of any electric machines that provide mechanical power to the road. With regard to (b), in the case that an electric machine delivers power from a series path, only the portion of the output power that originates from the REESS is counted.

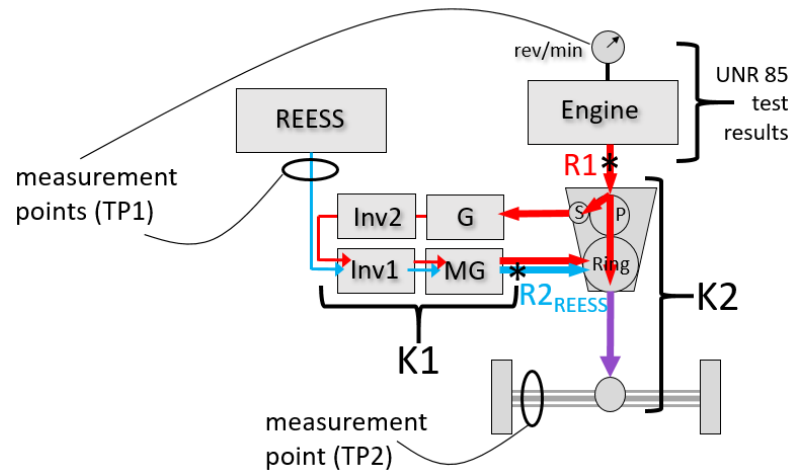

2.4 Pure series architectures

2.4.1 Pure series architectures include an ICE that powers one or more electrical conversion paths with no mechanical link between the engine and the road. The power determination reference points are generally (a) the engine mechanical power output shaft and (b) the mechanical power output shaft(s) of any electric machines that provide mechanical power to the road. With regard to (b), in the case that an electric machine delivers power from a series path, only the portion of the output power that originates from the REESS is counted.

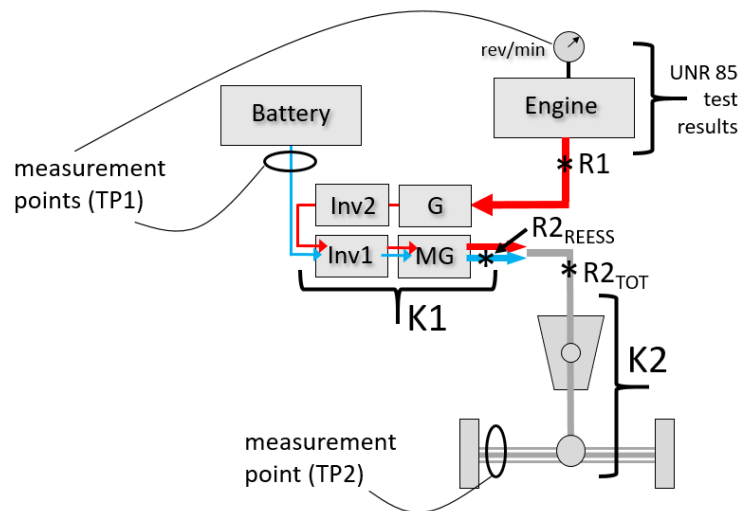

2.5 Architectures with more than one powered axle

2.5.1 When more than one axle propels the vehicle under the maximum power condition, and each axle is not powered by the same set of propulsion energy converters, there will commonly be reference points associated with a specific axle. Vehicles of this type must be tested at both axles simultaneously. An example is shown below. Power at R1 and R2 is delivered to one axle while power at R3 is delivered to the other axle.

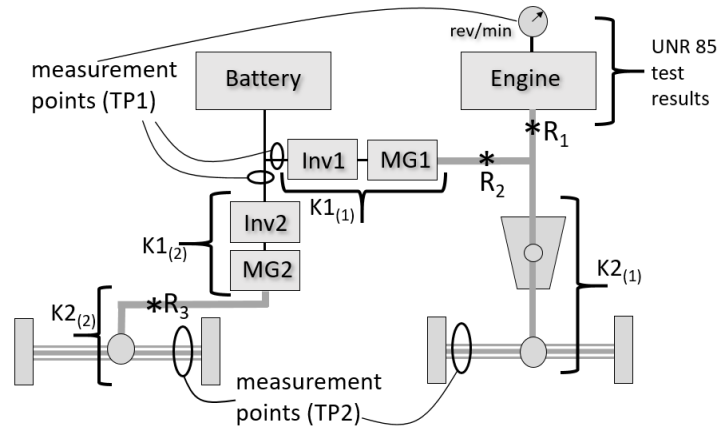

DRAFT - for discussion EVE33