

Draft for Alternative DVS Certification Method

For Discussion

OICA/ACEA supports the development of an easy to use physical certification method that correlates as much as possible with the DVS.

However, the suggested method in itself needs to be further analyzed.

Overview of the contents

- Introduction
- VRU height
- Test set-up
- Example of a self-levelling vertical laser
- General description of the methodology
- Methodology in real environment
- Direct vision line in real environment
- Methodology - simulation

Introduction



European
Automobile
Manufacturers
Association

- Goal is to present a proposal for a certification method for DVS in real environment for discussion in VRU-Proxi
- As demanded by VRU-Proxi the suggested method has to correlate as much as possible with DVS (DVS shall be the primary evaluation method)
- The suggested method is possible to perform in a real environment with simple tools and could be suitable to perform in serial production (COP Control)
- This proposal is only presented as an intermediate status in VRU-Proxi for discussion as it is not a final agreed proposal from OICA/ACEA as more work has to be done (e.g. correlation check with the DVS)

VRU height

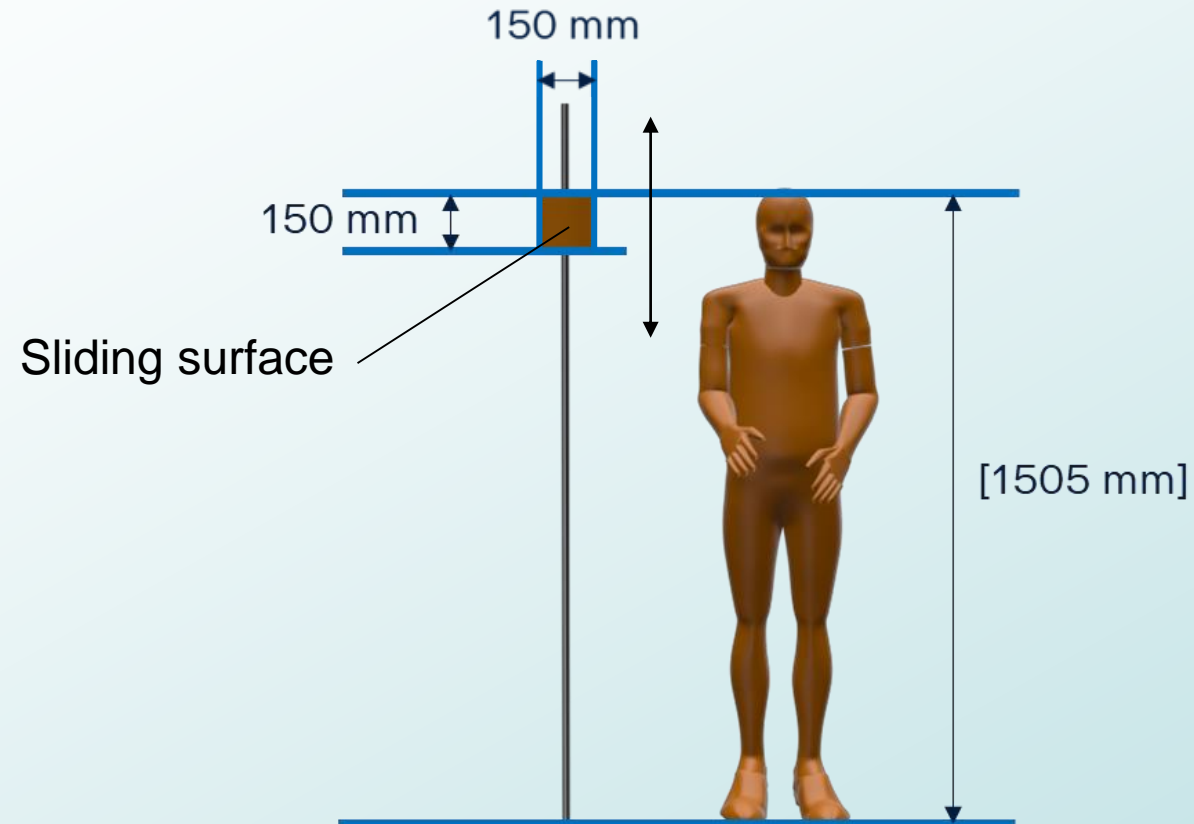

- VRU height to be discussed

Test set-up



Example of a self-levelling vertical laser

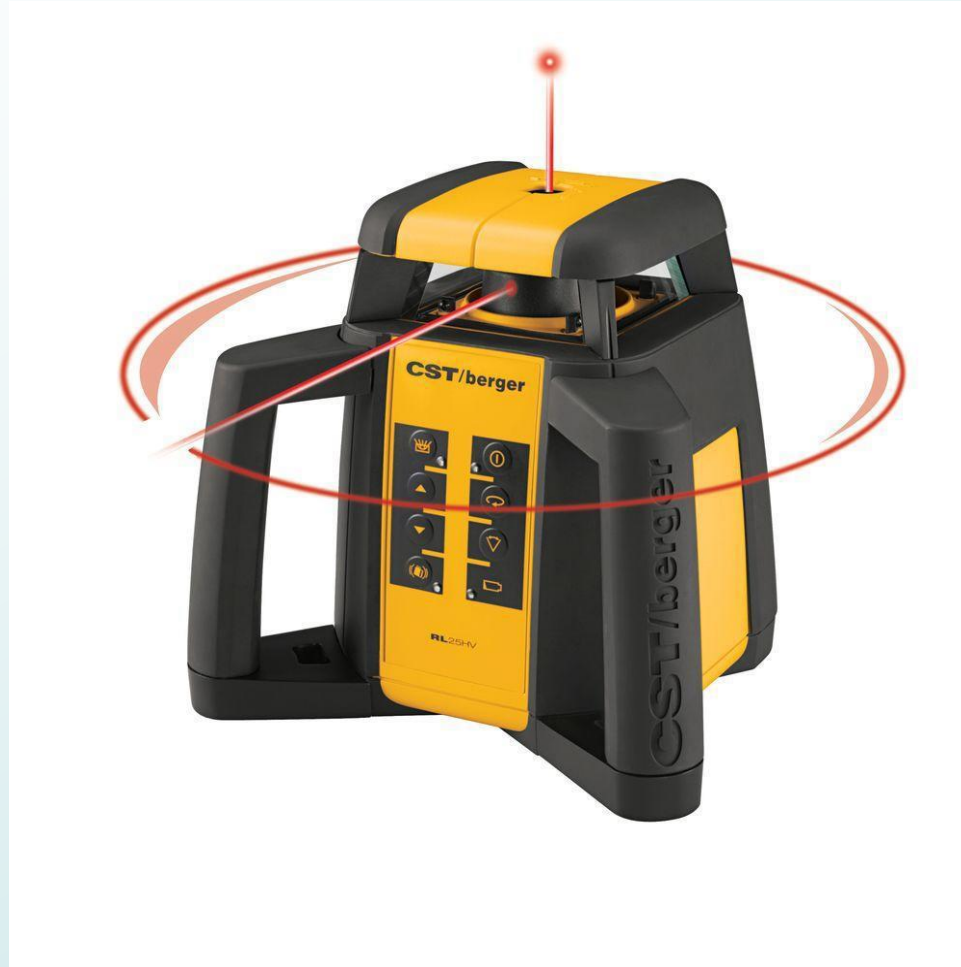

General description of the methodology

- Create a direct vision line that represent direct view (orange)
- Calculate average VRU height
- Approved if the calculated average VRU height is equal or less than the target VRU height
- Other height variants to be validated by CAD calculations

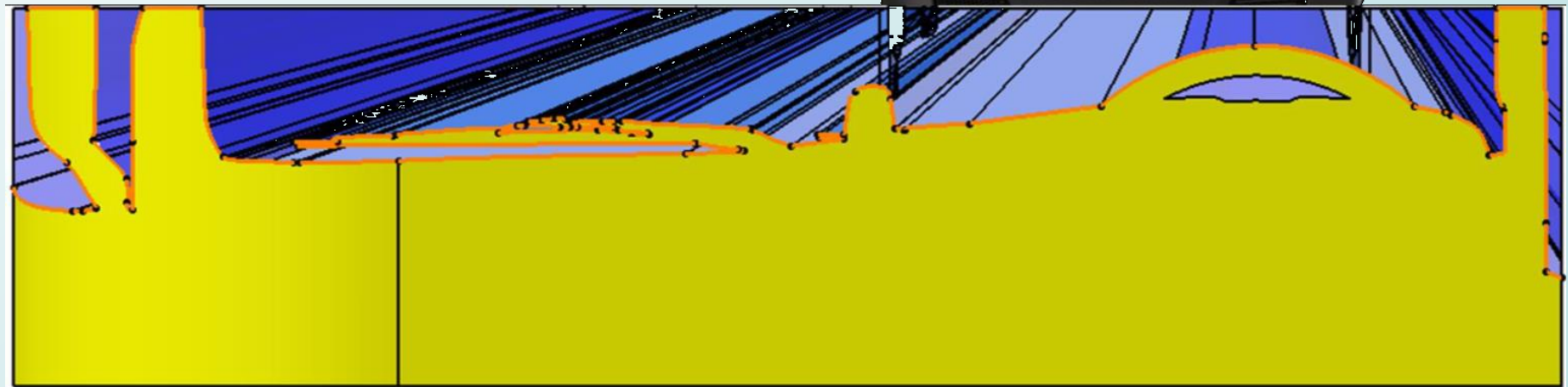

Methodology in real environment

- Reference line on the ground: 2 m in front of cab, 4,5 m on passenger side and 1 m on driver side with radius 2 m on passenger side (Red)
- From front edge of B pillar off-side to front edge B pillar nearside
- Measuring points are marked along the reference line on the ground at distance [x] or on a wall in front and side of the vehicle
- VRU height: [1505] mm as TFL DVS
- Visible acceptance of VRU: cube dimensions 15 cm x 15 cm or cylinder dimension 15 cm high and diameter 15 cm (same as for Reverse Detection)
- Target height: 1355 mm ($1505 - 150 = 1355$)
- Eye points: Same as TFL DVS

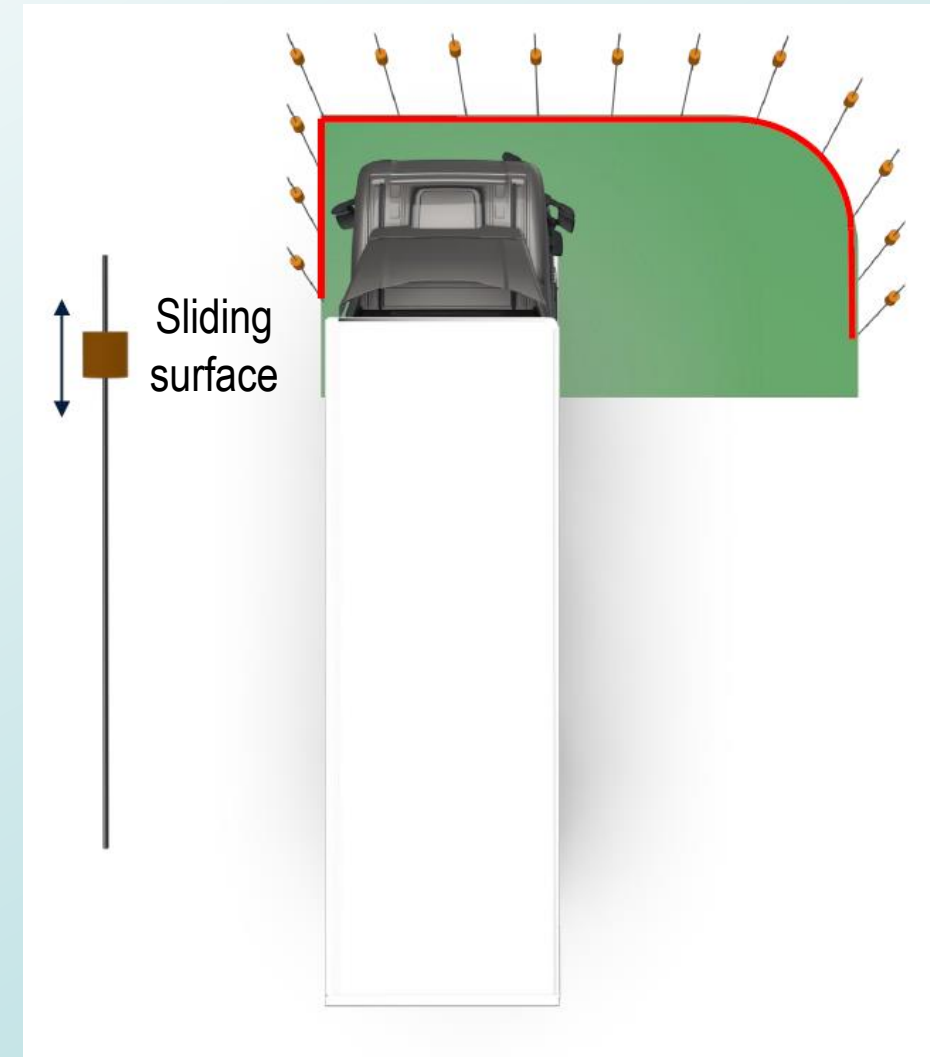

Methodology in real environment

- The measuring device is placed in each and every measuring point or marked on a wall to the front and side of the vehicle
- A self levelling vertical laser is placed in the eye point
- The cube is moved up or down along the measuring device until it is fully visible by the laser. The height is documented. If projected on walls instead, the height in each measuring point is documented
- If the cube is partly blocked by A pillar or mirror the height is set to 1602 mm (as TFL DVS) at that specific measuring point
- The values are summed up and the average VRU height is calculated
- Approved if average VRU height is equal or less than the target height [1355 mm]

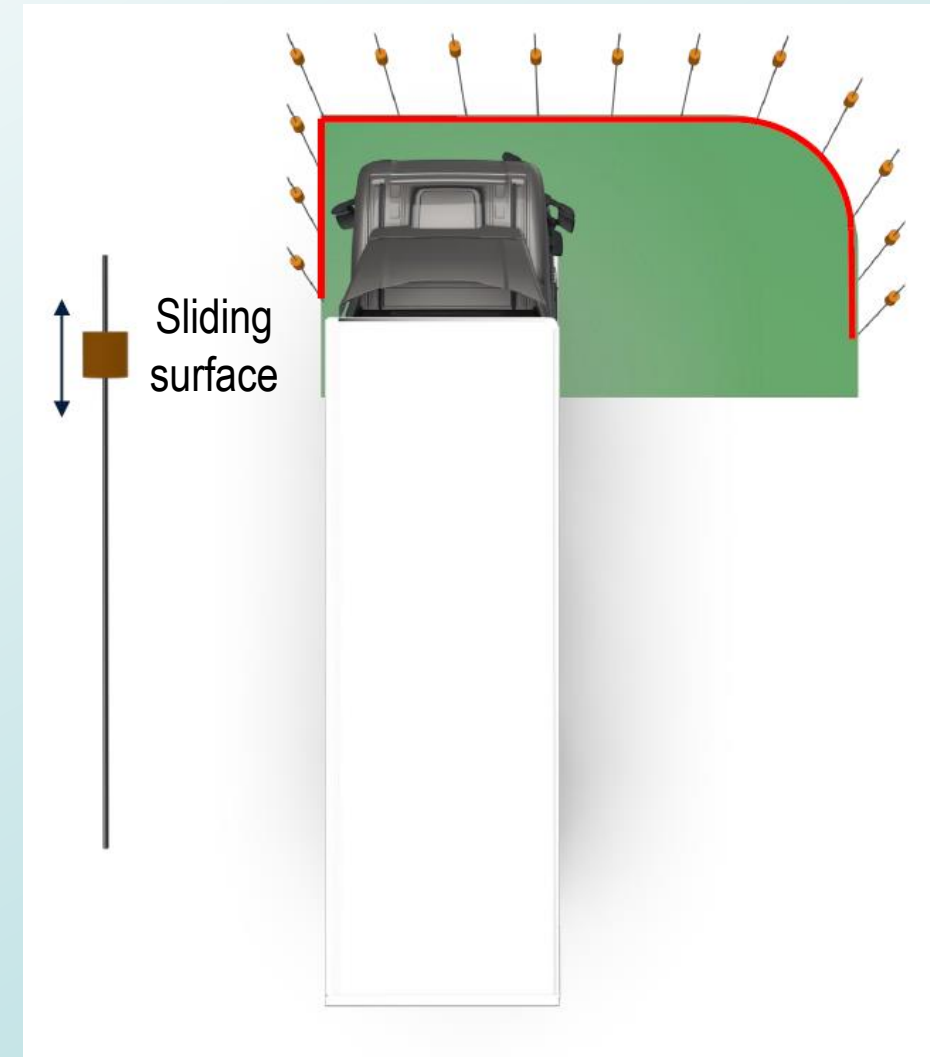

Direct vision line in real environment

When using measuring device

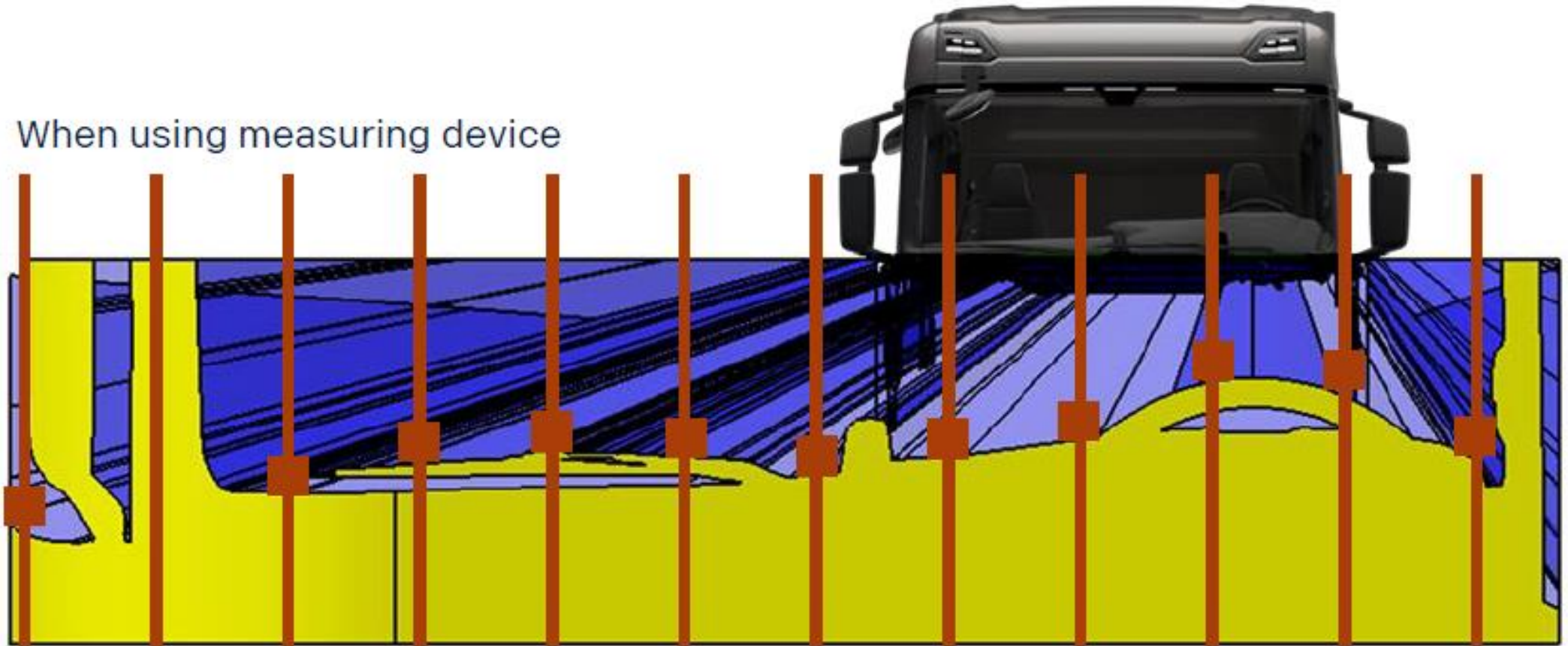

Direct vision line in real environment

When projected on a wall



Methodology - Simulation

- Reference line on the ground: 2 m in front of cab, 4,5 m on passenger side and 1 m on driver side with radius 2 m on passenger side
- From front edge of B pillar off-side to front edge B pillar nearside
- VRU height: 1505 mm as TFL DVS
- Visible acceptance of VRU: cube dimensions 15 cm x 15 cm or cylinder dimension 15 cm high and diameter 15 cm
- Eye points: Same as TFL DVS
- Direct vision cones are created from eye points
- A vertical surface is created along the reference line on the ground (yellow)
- A direct vision line (orange) is created in the intersection between the vertical surface and the direct vision cones representing what is visible to the driver



Methodology - Simulation

- Measuring points are created along the direct vision line at distance [x]
- The measuring points can be exported to excel
- The values are summed up and the average VRU height is calculated
- Or, to simplify the calculation, the area (yellow) of the vertical surface along the reference line and the length of the ground line could be used to calculate the average VRU height
- Approved if average VRU height is the equal or less than the target height [1355 mm]

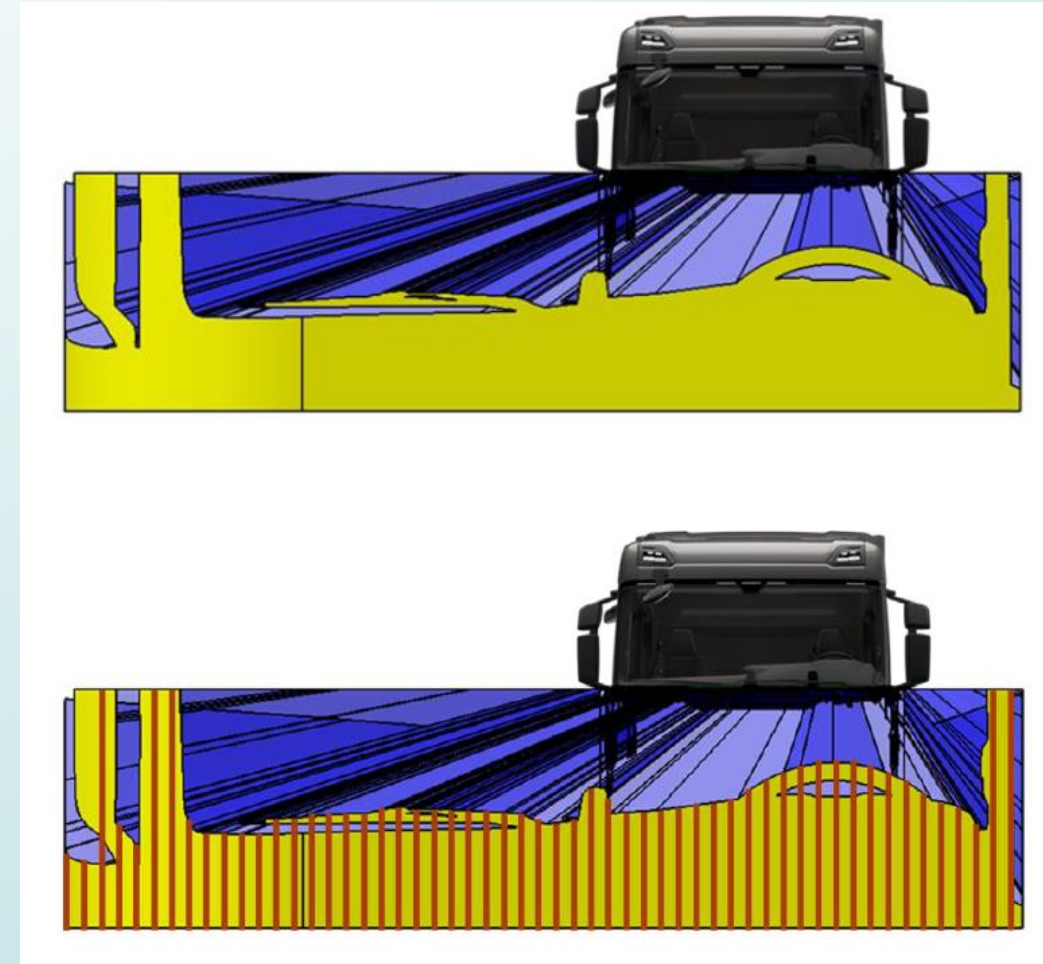

Methodology - Simulation



- If the vehicle is not approved, then a lower door window could be added to improve direct vision
- The area of the lower door window should be calculated at a distance of [2,5] m from the cab on the passenger side
- The calculated area should be subtracted from the total area

OICA/ACEA kindly asks LDS to investigate the correlation of this certification method with the DVS approach for the next VRU-Proxi meeting