



mir
sense

SENSORS FOR AIR QUALITY

MATHIEU CARRAS, CEO MIRSENSE

MARCH 10 2020 : VIAQ PARIS

PROVIDE COST EFFECTIVE SOLUTIONS FOR MULTI-CHEMICAL SENSING

PROTECT



DIAGNOSE



REASSURE

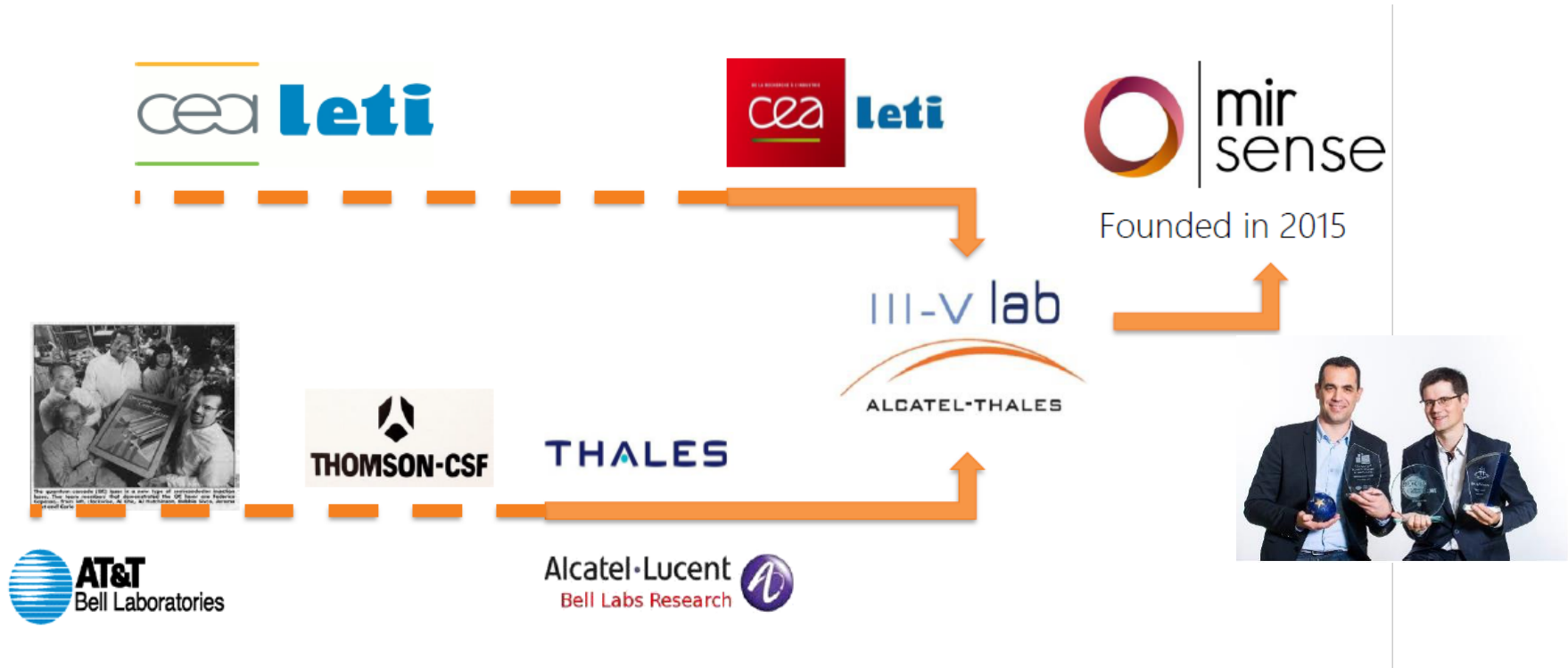

The team

- >20 people
- >10 PhD

Partners

- CEA/Thales/Nokia, VITESCO
- R&D project (Europe, ANR etc.)

Markets

- Lasers
- Gas Sensors

>2M€ fund raising in 2018



MULTISENSE

Multi-gas module for trace detection, process control, emission monitoring

Up to 4 gases simultaneous detection

Down to few 10 ppb now

€	Small	Robust	%
		User Friendly	ppm
			ppb



NH ₃			
NO ₂	H ₂ O		
N ₂ O	CF ₄	CO	
NO	CH ₄	CO ₂	H ₂ CO

WE FOCUS ON SOME DEFINED MOLECULES AND MARKETS, HERE IS THE ROADMAP:

- NO/NO₂/N₂O/NH₃ FOR EMISSION MONITORING AND AIR QUALITY
- CO/CO₂ FOR AIR QUALITY AND SECURITY
- HCs : CH₄, OTHER HCs
- VOC :
 - Formaldehyde
 - BETEX (Benzene, Toluene, ...)
- OTHER MOLECULES WITH SIGNATURES IN THE MID-INFRARED



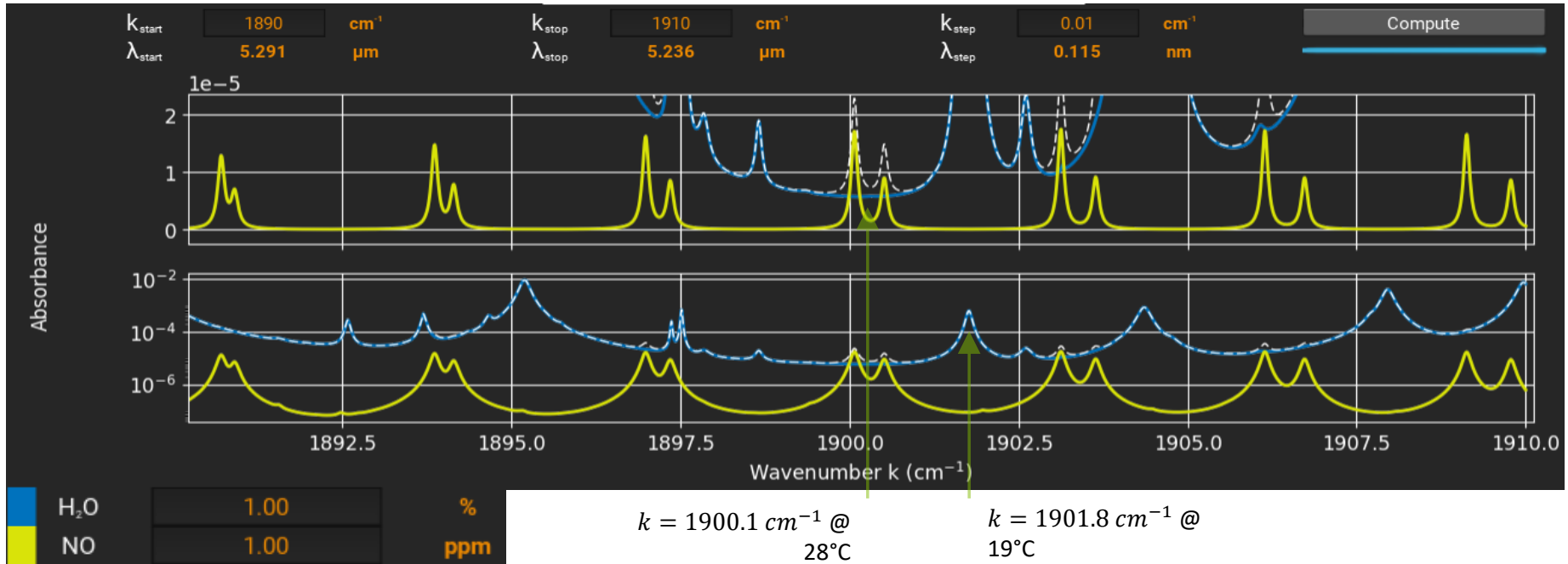

- Laser based feature
 - Direct absorption : no change in time (precision, stability)
 - High specificity (unique absorption features)
 - Fast : possible $\ll 1\text{s}$ response times

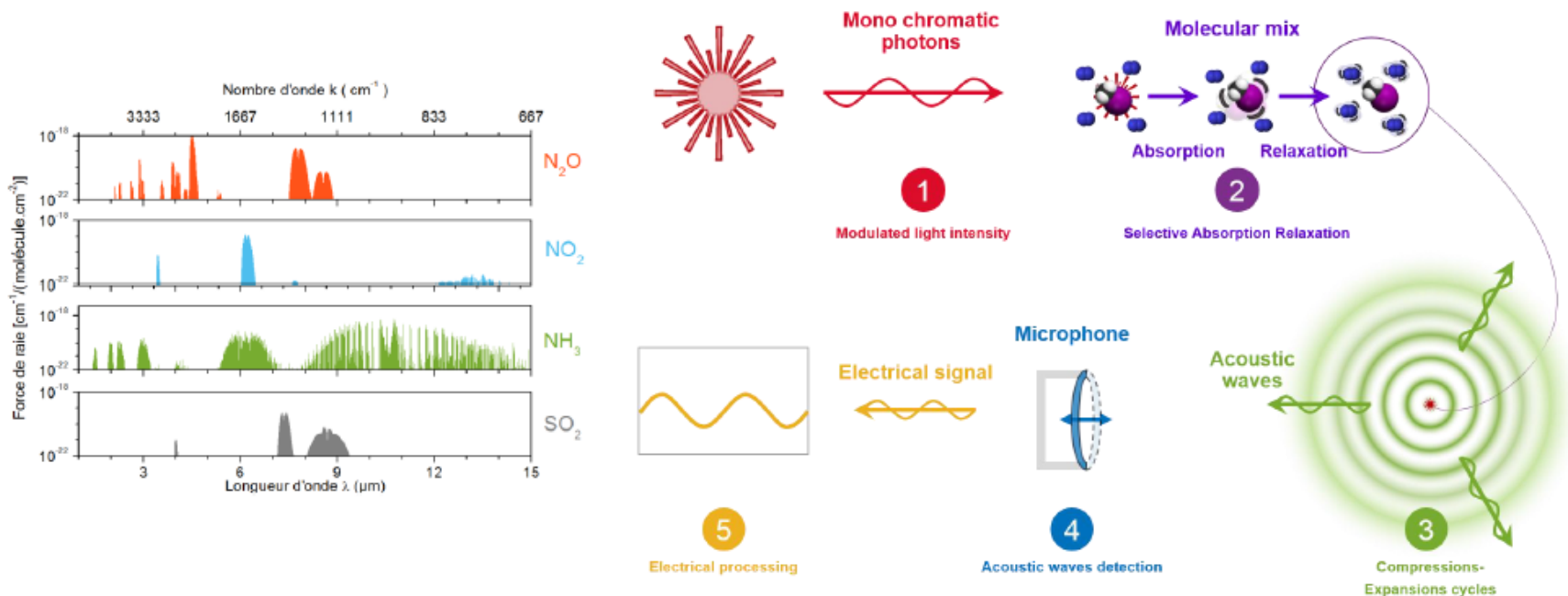

- 1 A Quantum Cascade laser shoots at a specific wavelength in the gas (one laser = one molecule).
- 2 The target molecules absorb the light (Beer–Lambert law) because the laser is tuned at the right wavelength.
- 3 Because the molecules absorb the laser energy which is modulated at an acoustic frequency, they will expand and compress and thus create a sound. The sound is proportional to the quantity of molecules in the gas.
- 4 Our sensor listens to the sound with built-in microphones.
- 5 Our sensor calculates the gas concentration (down to ppb levels) based on the sound level.



- Large dynamic range (6 decades of linearity)
 - Very small size
 - Heated gas cell to avoid water condensation
 - Pulsed lasers for wall plug efficiency
 - No backgrounds
 - No moving parts
- Detection depends on the gas matrix
 - External noise to be handled

- Versus FTIR: The multiSense is much faster, has a much smaller sampling flow rate (<40ml/mn) and uses much less sample gas than the FTIR. It is also much more compact. The FTIR is better suited to scan an unknown gas matrix and find out what components are there whereas the multiSense is better suited to detect specific components.
- Versus NDIR: The multiSense has less cross-interference problems than NDIR techniques because of the QCL laser technology used by multiSense (better selectivity) and it is also more sensitive.
- Versus multi-pass optical detection: The multiSense has no optics and is much more robust than multi-pass cells that have alignment problems. Optical detectors are saturated when detecting high concentration of molecules whereas multiSense has 6 decades of dynamic range.

- Versus Gas Chromatography: The multiSense is **much faster** (seconds) when GCs are slow (typ. minutes).
- Versus Chemiluminescence: Chemiluminescence is very complex, it creates ozone and the regulation is tightly controlled. **MultiSense is easier to use.**
- Versus electrochemical cells: have a high reaction time, they dry out, need to be recalibrated often, sometimes weekly and if they are saturated, you must wait 6 hours with no data for the cell to come back to normal and they can't take in gases heated above +120°C. **MultiSense measures in seconds, has no saturation issue and can measure up to +200°C.**
- Versus other photoacoustic sensors : MultiSense uses pulsed lasers, not continuous lasers and that means that the OEM module **dissipates less heat and requires less current consumption.**
- Versus cross-duct measurement: multiSense can measure at high T several components.

Sensitive and specific

- Laser spectroscopy (very selective, discriminate NO/NO₂)
- Mid infrared wavelength (very sensitive)

Robustness

- No optics (vibration friendly)
- Hermitically sealed

Compact

- Handheld
- Embedded signal treatment
- Versatile FPGA architecture for custom needs

Cost effective

- Use of semiconductor technologies
- Modular design for easy maintenance

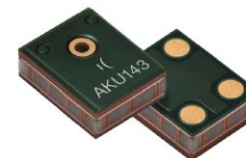

Parameter	Value / Range
Gas	NO
Principle of detection	Mid-IR laser spectroscopy
Measuring range	0 -1000ppm
Limit of Detection ¹	<0.3ppm @ 60s integration time (post acquisition average) <1ppm @ 10s integration time (post acquisition average)
Accuracy ²	The LOD or 2% of the read value (whichever is greater)
Precision ³	LOD or 2% of the read value (whichever is greater)
Linearity	Included in the accuracy. Linear regime detection
Displayed resolution	0.01ppm (negative values also displayed)
Response time ⁴	0.1 s
T90 ⁵	<1s
Cell temperature (controlled temperature)	50°C
Input for external parameter compensation	Pressure compensation
Calibration	By Software

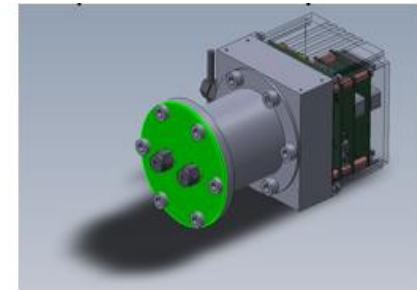
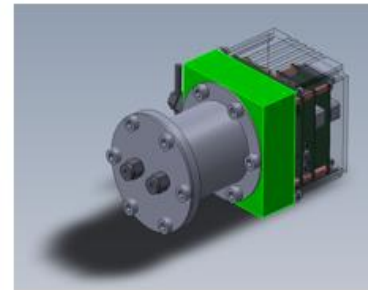
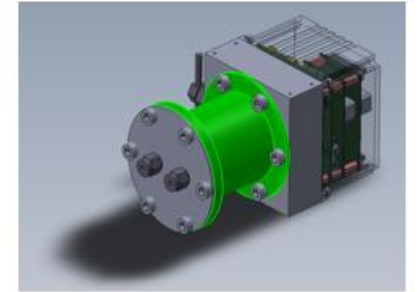
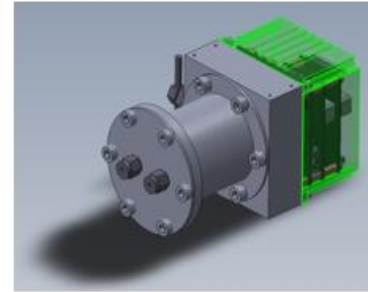
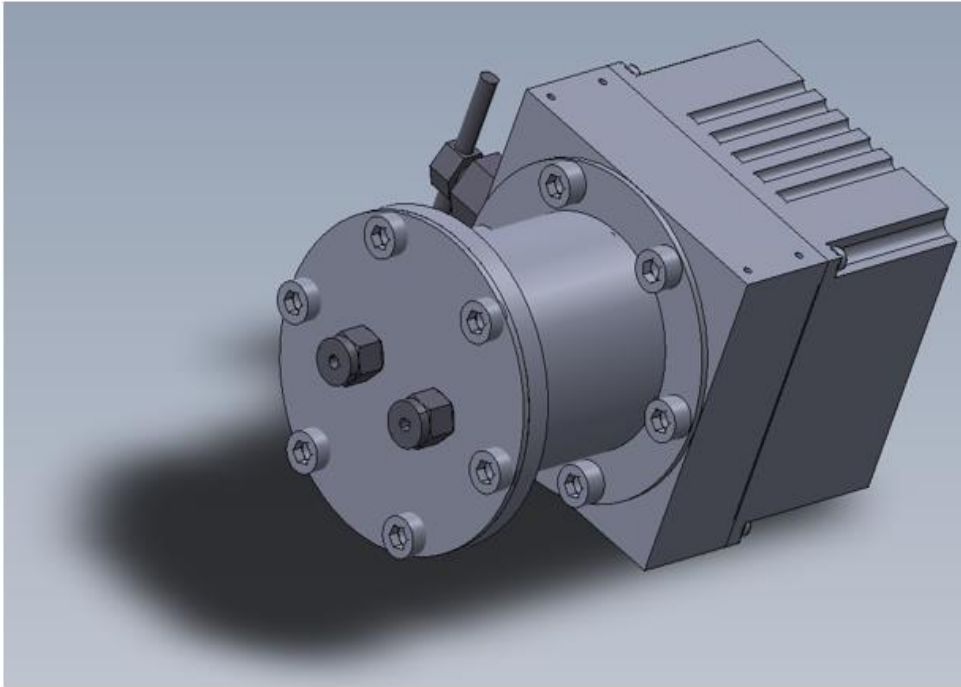

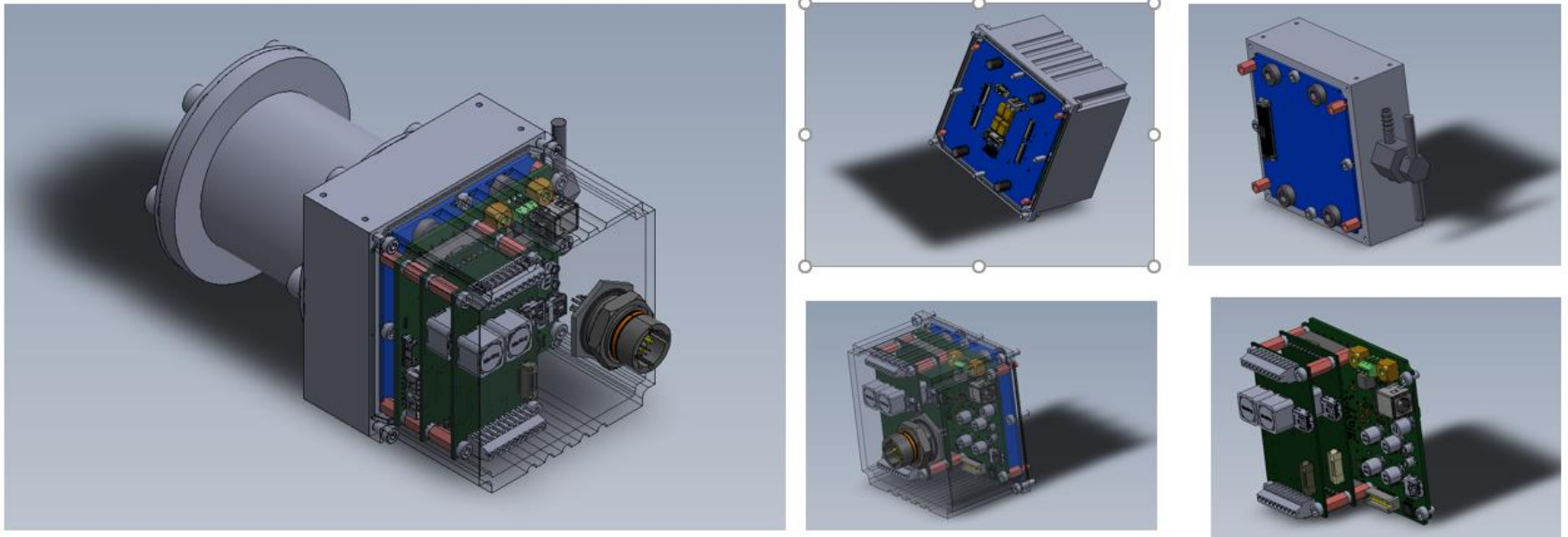

IP68 HERMETIC SEALING

HIGH QUALITY CONNECTORS FOR MODBUS COMMUNICATION

LOD DOWN TO FEW 10 PPB

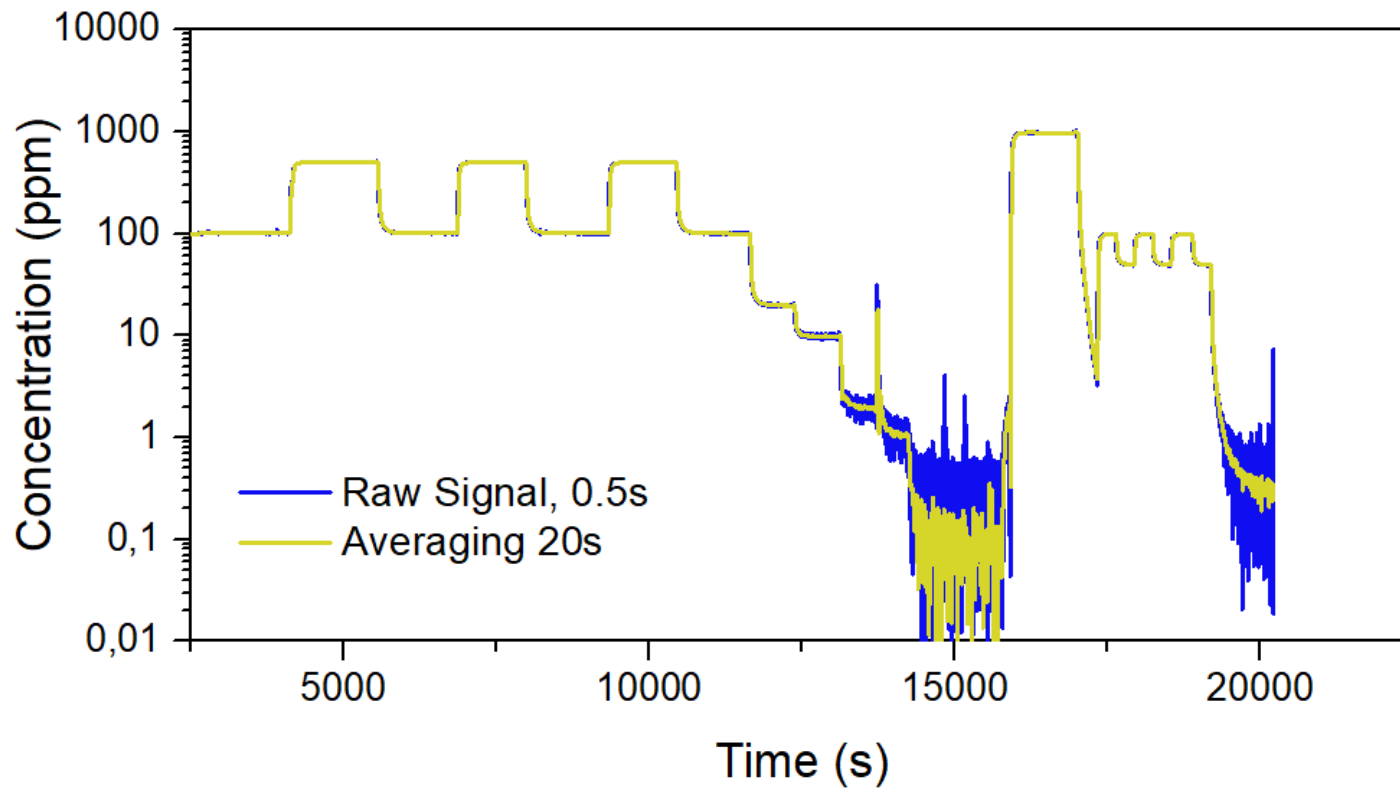

- ❑ PRODUCT IN SMALL SCALE PRODUCTION

- ❑ AVAILABLE FOR EARLY ADOPTERS:
 - ❑ NO NO₂
 - ❑ Soon other molecules (few months)





mir
sense

contact@mirsense.com

+33 6 82 96 26 43

+33 1 69 08 05 89



Centre d'intégration NanoInnov,
8 avenue de la Vauve, Bâtiment 863, 91120 Palaiseau
CEA-LETI, 17 rue des Martyrs, 38054 Grenoble cedex 9