

Draft: **ECE-R XXX**

Testing: Mechanical coupling devices for agricultural vehicles
Last updated: 21 July 2011

Regulation No. XXX

**Uniform Provisions Concerning the Approval of Mechanical Coupling Components for
Agricultural Vehicles**

Content

Regulation No. XXX	1
1 Scope	3
2 Definitions	3
3 Application for approval of a mechanical coupling device or component	9
4 General requirements for mechanical coupling devices or components	10
5 General requirements for vehicles fitted with a mechanical coupling device or component	11
6 Markings	12
7 Approval	12
8 Modifications to the mechanical coupling device or component, or to the vehicle and extension of approval	13
9 Conformity of production procedures	13
10 Penalties for non-conformity of production	13
11 Production definitely discontinued	14
12 Transitional provisions	14
13 Names and addresses of technical services responsible for approval tests and of administrative departments	14

Draft: ECE-R XXX

Testing: Mechanical coupling devices for agricultural vehicles

Last updated: 21 July 2011

Annexes

- Annex 1 –Communication concerning the approval or extension or refusal or withdrawal of approval or production definitely discontinued of a type of mechanical coupling device or component pursuant to Regulation No. XXX
- Annex 2 **Assignment of mechanical coupling devices of towing vehicles or self-propelled machines and towed vehicles**
- Annex 3 Example of an arrangement of the approval mark
- Annex 4 Examples of arrangements of marking of the characteristic values
- Annex 5 Requirements for mechanical coupling devices or components
- Annex 6 Testing of mechanical coupling devices or components
- Appendix 1 - **Va value diagram**
- Appendix 2 - **Provisions for a theoretical check of mechanical coupling devices for full trailers**

(Former appendices 1 and 2 have been subsumed within annex 6 or are no longer necessary)

Draft: **ECE-R XXX**

Testing: Mechanical coupling devices for agricultural vehicles
Last updated: 21 July 2011

1 Scope

1.1. This regulation applies to mechanical coupling devices for agricultural and forestry tractors and self-propelled machines and trailers and towed implements towed by them.

For the purpose of this regulation, “trailer” refers to both trailers and towed implements

1.2. This Regulation applies to:

1.2.1. standard devices and components as defined in paragraph 2.3;

1.2.2. non-standard devices and components as defined in paragraph 2.4;

1.2.3. non-standard miscellaneous devices and components as defined in paragraph 2.5.

1.3. This Regulation does not apply to:

1.3.1. power lifts (three-point hitch) or tractor linkage drawbars attached to lower link arms;

1.3.2. drawbars on towed, interchangeable machines which are intended for connection to the devices listed under 1.3.1.

1.4. ~~Approvals pursuant to R 55 (as last amended) are considered equivalent.~~^[SP1]

2 Definitions

For the purposes of this Regulation:

2.1. “mechanical coupling devices and components” means all those items on the frame, load-bearing parts of the bodywork or chassis of the towing vehicle or self-propelled machine or of the trailer by means of which they are connected together to form the combination of vehicles. Fixed or detachable parts for the attachment or operation of the mechanical coupling device or component are included.

2.2. coupling devices may be automatic or non-automatic. Automatic coupling requirement is achieved if the coupling engages completely, is locked automatically and proper engagement of the locking devices is indicated without any external intervention.

2.3. standard mechanical coupling devices and components conform to standard dimensions as given in this Regulation. They are **interchangeable** within their class, independent of manufacturer **with regard to mounting dimensions and may be connected to standard mechanical coupling devices and components of the appropriate class in accordance with annex 2.**

Draft: ECE-R XXX

Testing: Mechanical coupling devices for agricultural vehicles

Last updated: 21 July 2011

2.4. non-standard mechanical coupling devices and components do not conform in all respects to the standard dimensions given in this Regulation but can be connected to standard coupling devices and components in the relevant class.

2.5. non-standard miscellaneous mechanical coupling devices and components do not conform to the standard dimensions given in this Regulation, but can be connected to standard coupling devices and components.

They include, for example, devices which do not correspond to any of the Classes a to j listed in paragraph 2.6, such as those intended for special, heavy transport use and miscellaneous devices conforming to existing national standards.

2.6. mechanical coupling devices and components are classified according to type as follows: [SP2]

2.6.1. Class a Coupling ball 80 and keeper plate employing a spherical device and brackets on the towing vehicle for connecting to the trailer by means of a ball-shaped scraper 80 (ISO 24347:2005).

2.6.1.1. Class a80-1: Coupling ball 80 with standard flange-type bolted fixing.

2.6.1.2. Class a80-2: Coupling ball 80 with standard latching rail plate.

2.6.1.3. Class a80-3: Coupling ball 80 with other fixing.

~~X[SP2]:~~

2.6.2. Class b: Ball-shaped scraper 80, mounted on the drawbar of trailers for connecting to a coupling ball 80 on the towing vehicle (ISO 24347:2005).

2.6.2.1. Class b80-1: Ball-shaped scraper 80 with standard welding shank.

2.6.2.2. Class b80-2: Ball-shaped scraper 80 with standard flange-type bolted fixing.

2.6.2.3. Class b80-3: Ball-shaped scraper 80 with standard horizontal flange-type bolted fixing.

2.6.2.4. Class b80-4: Ball-shaped scraper 80 with standard other fixing.

~~4[SP4]:~~

~~2.6.3. Class c: Clevis type couplings with a pin (30 mm to 38 mm diameter), a jaw and an automatic or non-automatic closing and locking pin on the towing vehicle for connecting to the trailer by means of a coupling ring (ISO 6489-2:2002).~~

~~2.6.3.1. Class c40-1: Clevis type couplings (30 mm to 38 mm diameter) with standard flange-type bolted fixing~~

~~2.6.3.2. Class c40-2: Clevis type couplings (30 mm to 38 mm diameter) with standard latching~~

Draft: **ECE-R XXX**

Testing: Mechanical coupling devices for agricultural vehicles

Last updated: 21 July 2011

2.4. non-standard mechanical coupling devices and components do not conform in all respects to

~~rail plate.~~

2.6.3.3. Class e40-X: ~~Clevis type couplings (30 mm to 38 mm diameter) with other fixing.~~

Draft: ECE-R XXX

Testing: Mechanical coupling devices for agricultural vehicles

Last updated: 21 July 2011

2.4. non-standard mechanical coupling devices and components do not conform in all respects to

~~2.6.4. Class d1: Coupling rings 40 having a cylindrical hole suitable for a pin (30 mm to 38 mm diameter) and fitted to the drawbar of trailers for connecting to clevis type couplings (ISO 8755:2001).~~

~~2.6.4.1. Class d1-40-1: Coupling rings (for a 30 mm to 38 mm diameter pin) with standard welding shank~~

~~2.6.4.2. Class d1-40-2: Coupling rings (for a 30 mm to 38 mm diameter pin) for standard threaded attachment.~~

~~2.6.4.3. Class d1-40-3: Coupling rings (for a 30 mm to 38 mm diameter pin) with standard flange-type fixing.~~

Draft: ECE-R XXX

Testing: Mechanical coupling devices for agricultural vehicles

Last updated: 21 July 2011

~~2.6.4.4. Class d1-40-4: Coupling rings (for a 30 mm to 38 mm diameter pin) with other fixing.~~

2.6.5. Class d2: Coupling rings 40 having a cylindrical hole suitable for a pin (30 mm to 38 mm diameter) and fitted to the drawbar of a trailer for connecting to a clevis-type coupling (ISO 5692-2:2002) 38 mm diameter) and fitted to the drawbar of a trailer for connecting to a clevis-type coupling (ISO 5692-2:2002).

2.6.5.1. Class d2-40-1: Coupling rings (for a 30 mm to 38 mm diameter pin) with standard welding shank

2.6.5.2. Class d2-40-2: Not currently allocated

2.6.5.3. Class d2-40-3: Non swivel Coupling rings (for a 30 mm to 38 mm diameter pin) with type fixing

2.6.5.4. Class d2-40-4: Coupling rings (for a 30 mm to 38 mm diameter pin) with other fixing.

2.6.6. Class d3: Coupling rings having a hole with a circular cross-section and 50 mm diameter (hitch rings), which are fitted to trailer drawbars for connecting to a hitch hook (class g) or piton-type coupling (class h) (ISO 5692-1:2004)

2.6.6.1 Class d3-50-1 Hitch rings with standard welding shank.

2.6.6.2 Class d3-50-2 HitchCoupling rings with standard flange type fixing.

2.6.6.3 Class d3-50-3 HitchCoupling rings with other fixing.

Draft: **ECE-R XXX**

Testing: Mechanical coupling devices for agricultural vehicles

Last updated: 21 July 2011

2.6.4.4. ~~Class d1-40-4: Coupling rings (for a 30 mm to 38 mm diameter pin) with other fixing.~~

~~2.6.7 Class d4: Coupling rings having a hole with a 50 mm diameter, which are fitted to trailer drawbars for connecting to a hitch hook (class g) or a piton-type coupling (class h) (ISO 20010:2001).~~

~~2.6.7.1 Class d4-50-1: Coupling rings with standard welding shank.~~

Draft: **ECE-R XXX**

Testing: Mechanical coupling devices for agricultural vehicles

Last updated: 21 July 2011

2.6.4.4. ~~Class d1-40-4: Coupling rings (for a 30 mm to 38 mm diameter pin) with other fixing.~~

2.6.7.2 ~~Class d1-50-2 Coupling rings with standard flange type bolted fixing.~~

Draft: ECE-R XXX

Testing: Mechanical coupling devices for agricultural vehicles

Last updated: 21 July 2011

~~2.6.4.4. Class d1-40-4: Coupling rings (for a 30 mm to 38 mm diameter pin) with other fixing.~~

~~2.6.7.3 Class d4-50-3 Coupling rings with other fixing.~~

- 2.6.8. Class e Non-standard drawbars comprising forked and other drawbars, overrun devices and similar items of equipment mounted on the front of the towed vehicle, or on the vehicle chassis, which are suitable for coupling to the towing vehicle by means of coupling rings, ball-shaped scrapers or similar coupling devices.
Drawbars may be hinged to move freely in a vertical plane and not support any vertical load or be fixed in a vertical plane so as to support a vertical load (rigid drawbars). Rigid drawbars can be entirely rigid or be spring-mounted or adjustably (e.g. hydraulically) mounted.
Drawbars may also comprise more than one component and may be adjustable or cranked.
- 2.6.9. Class f: Towing brackets, comprising all components and devices fitted between the coupling devices, for example coupling balls or clevis-type couplings, and the rear axle, transmission, load-bearing parts of the bodywork or chassis of the towing vehicle.
- 2.6.9.1. Class f-1: Towing brackets for standard quick height-adjustable (qha) latching rail plates
- 2.6.9.2. Class f-2: Towing brackets for height-adjustable, detachable coupling devices

Draft: **ECE-R XXX**

Testing: Mechanical coupling devices for agricultural vehicles

Last updated: 21 July 2011

- 2.6.9.3. Class f-X: Other towing brackets
- 2.6.10. Class g: Hitch hooks with a keeper plate and a lowering device operated using external power for remote-controlled coupling and uncoupling for connecting to the trailer using hitch rings (ISO 6489-1:2001).
- 2.6.11. Class h: Piton-type couplings with a keeper plate which are connected to the trailer by means of hitch rings (ISO 6489-4:2004).
- 2.6.12. Class j: Non-standard coupling balls with a diameter greater than 80 mm.
- 2.6.13. Class k: Non-standard ball-shaped scrapers with a diameter greater than 80 mm.
- 2.6.14. Class m: Non-standard mounting plates comprising all components and devices for attaching fifth wheel couplings to the frame or chassis of the towing vehicle. The mounting plate may have provision for moving horizontally, that is to form a sliding fifth wheel.
- 2.6.15. Class s: Coupling devices and components which do not conform to any of the Classes a to m and which are used, for example, for special applications or are devices unique to some countries and covered by existing national standards.

[SP6]

2.7. Remote control systems are devices and components which enable the coupling device to be operated from the side of the vehicle or from the driving cab of the vehicle.

2.8. Remote indicators are devices and components which give an indication in the vehicle cab or optionally at the actuation point that coupling has been effected and that the locking devices have engaged. [SP7]

Note: Annex 5 does not contain any requirements for remote control systems or remote indicators!!!
(Even the colour of the control light is not specified.)

2.9. "Type of coupling device or component" means a device or component which does not differ in such essential respects as:

2.9.1. manufacturer,

2.9.2 the class of coupling as defined in paragraph 2.6

2.9.3. the external shape, principal dimensions or design, including types of materials used,

2.9.4. the characteristic values D, D_c, S, C and V_{max} as defined in paragraph 2.10. Combinations of characteristic values based on tested original values are permissible.

2.10. Symbols and definitions used in this Regulation:

Testing: Mechanical coupling devices for agricultural vehicles

Last updated: 21 July 2011

Vehicle characteristic values

- A_v Technically permissible axle load, in tonnes, of the steered axle of a full trailer.
- C The mass, in tonnes, transmitted to the ground by the axle or axles of a rigid drawbar trailer as defined in paragraph 2.13 when coupled to the towing vehicle and loaded to the technically permissible maximum mass¹.
- D / D_c The D or D_c value is the theoretical reference value for the towing force between the towing vehicle and the trailer and is used as the basis for test loads during dynamic testing.

For all mechanical coupling devices and components installed on the tractor not designed to support imposed vertical loads, the value is:

$$D = \frac{T}{g} - \frac{R}{g} \quad [kN]$$

$$D/D_c = g * T * 0.8 \quad [kN]$$

For mechanical coupling devices and components which are designed to support imposed vertical loads, the value is:

$$D_c = \frac{T * C}{T + C} \quad [kN]$$

- T The technically permissible maximum mass of the towing vehicle in tonnes. Where relevant, this includes the vertical load imposed by a rigid drawbar trailer¹.

For mechanical coupling devices and components installed on trailer the value is:

$$D = g * R * 0.6 \quad [kN]^{[SP8]}$$

- R The technically permissible maximum mass, in tonnes, of a trailer with a drawbar which is free to move in a vertical plane.

- S The S value is the vertical load, in kilograms, imposed on the coupling under static conditions by a rigid drawbar trailer, as defined in paragraph 2.13, of the technically permissible maximum mass¹.

- v_{max} Maximum permissible speed

Test forces and calculation parameters

- F_a Static lifting force in kN
- F_h Horizontal component of the test force in the longitudinal axis of the vehicle in kN
- F_v Vertical component of the test force in kN

~~V_a change? Note: according to the~~
The V_a value is an operand for the drawbar strength test and corresponds to the theoretical reference value of the amplitude of the vertical force imposed on the coupling by a rigid drawbar trailer. The V_a value serves as the basis for the vertical forces during theoretical checks (see also annex 6, appendix 1).

~~subscripts, a means static~~

$$V_a = \frac{(a * m_1 + b) * g * h}{t} \quad [kN]$$

a ————— A correction factor which depends on the rigid drawbar trailer's permissible maximum mass m₁, where:

The V value is the theoretical reference value of the amplitude of the vertical force imposed on the coupling by the centre axle trailer. The V value is used as the basis for vertical forces in the dynamic tests.

$$V = 0,7 * C * \frac{h}{l}$$

Where is not know, the factor $\frac{h}{l}$ must be assumed as $\frac{h}{l} = 0,4$ [SP9]

Testing: Mechanical coupling devices for agricultural vehicles

Last updated: 21 July 2011

$a = 0.83$ for $m_1 < 3.5$ t,
 $a = 0.52$ for $m_1 \geq 3.5$ t and ≤ 12.0 t,
 $a = 0.85$ for $m_1 > 12.0$ t.

b — A correction factor which depends on the rigid drawbar trailer's permissible maximum mass m_1 , where:

$b = 0.0$ t for $m_1 < 3.5$ t,
 $b = 1.1$ t for $m_1 \geq 3.5$ t and ≤ 12.0 t,
 $b = 2.8$ t for $m_1 > 12.0$ t.

d — The value d is a speed coefficient which depends on the speed and brakes of the rigid drawbar trailer and is used as the basis for calculating the V value during theoretical checks, where:

$d = 1.00$ — for braked trailers with a speed of up to 80 km/h
 $d = 0.90$ — for braked trailers with a speed of up to 60 km/h
 $d = 0.80$ — for braked trailers with a speed of up to 40 km/h
 $d = 0.45$ — for trailers without brakes with a speed of up to 40 km/h.

h — The height in metres of the trailer's centre of gravity when loaded to the permissible maximum mass (see Figure 1). Unless otherwise specified by the applicant, a value of 0.4 is assumed for the $h:l$ ratio.

l — The distance in metres between the centre of the coupling ring and the centre of the axle assembly, in metres (see Figure 1).

m_1 — The technically permissible maximum mass of the rigid drawbar trailer C + S, in tonnes.

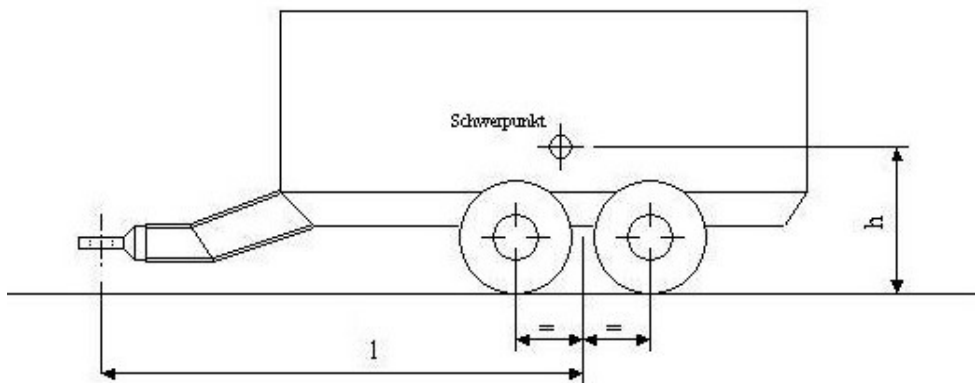

Figure 1

Subscripts Note: subscripts are not forces

O maximum

U minimum

Draft: **ECE-R XXX**

Testing: Mechanical coupling devices for agricultural vehicles

Last updated: 21 July 2011

a	static
h	horizontal
s	pulsating
res	resultant
v	vertical
w	alternating

- 2.11. "Rigid drawbar trailer" means a towed vehicle with one axle or axle group, a drawbar which is not able to rotate relative to the vehicle or, due to the presence of a suspension system (for example), can only rotate to a limited extent about one axis – parallel to the road surface and transverse to the direction of travel – and is therefore able to transmit vertical forces to the towing vehicle. A part of the weight of such a trailer is borne by the towing vehicle. A hydraulically adjustable articulated drawbar is considered to be a rigid drawbar.
- 2.12. "Positive mechanical engagement" means that the design and geometry of a device and its component parts shall be such that it will not open or disengage under the action of any forces or components of forces to which it is subject during normal use or testing.
- 2.13. "Vehicle type" means vehicles which do not differ in such essential respects as the structure, dimensions, shape and materials in areas to which the coupling device or component is affixed. This applies to both the towing vehicle and trailer.

3 Application for approval of a mechanical coupling device or component

- 3.1 The application for approval shall be submitted by the manufacturer, or by his duly accredited representative.
- 3.2 For each type of mechanical coupling device or component the application shall be accompanied by the following information, for example, by means of the Communication form given in annex 1:
- 3.2.1 full details of all manufacturer's or supplier's trade names or marks to be applied to the coupling device or component;
- 3.2.2 drawings which are sufficiently detailed to permit identification of the type of device or component and which specify how it is to be fitted to the vehicle; the drawings shall show the position of and space provided for the approval mark and other markings as defined in paragraph 7;
- 3.2.3 a statement of the values of D, D_c, S, C and V_{max} as applicable and as defined in paragraph 2.10;
- 3.2.4 a detailed technical description of the device or component, specifying, in particular, the type and the materials used;

Draft: **ECE-R XXX**

Testing: Mechanical coupling devices for agricultural vehicles

Last updated: 21 July 2011

- 3.2.5 one sample, plus additional samples as requested by the type approval authority or technical service;
- 3.2.6 all samples shall be fully finished with the final surface treatment applied. If, however, the final treatment consists of painting or powder coating, this should be omitted;
- 3.2.7 in the case of a mechanical coupling device or component designed for a specific vehicle type, the manufacturer of the device or component shall also submit the mounting dimensions specified by the vehicle manufacturer. The type approval authority or technical service may also request that a vehicle representative of the type for which approval is sought be presented.

4 General requirements for mechanical coupling devices or components

- 4.1 Each sample shall conform to the dimensional and strength specifications set out in annexes 5 and 6. Following the dynamic and static tests specified in annex 6, there shall not be any cracks, fractures or any excessive permanent distortion which would be detrimental to the satisfactory operation of the device or component.
- 4.2 All parts of the mechanical coupling device or component, whose failure could result in separation of the vehicle and trailer, shall be made of steel or nodular cast iron^[SP10]. Other materials may be used provided that equivalence has been demonstrated by the manufacturer to the satisfaction of the type approval authority or technical service of the Contracting Party applying this Regulation.
((Diskussionspunkt für FKT-SdA: Für GGG, GT und Feinkornbaustähle den technischen Inhalt der KBA-Richtlinien als weiteren Anhang übernehmen?))
- 4.3 The mechanical coupling devices or components shall be safe to operate and coupling and uncoupling shall be possible by one person without the use of tools. If it is impossible for the driver to observe the coupling process from the driver's seat, only devices which permit automatic coupling shall be allowed for trailers having a maximum technically permissible mass greater than 3.5 tonnes.
- 4.4 The mechanical coupling devices or components shall be designed and manufactured such that in normal use and with correct maintenance and replacement of wearing parts they will continue to function correctly and retain the characteristics prescribed by this Regulation.
- 4.5 All mechanical coupling devices or components shall be designed to have positive mechanical engagement and the closed position shall be locked at least once by further positive mechanical engagement unless specified otherwise in annex 5. Alternatively there may be two or more separate arrangements to ensure operational safety of the device, but each arrangement shall be designed to have positive mechanical engagement and shall be tested individually to any requirements defined in annex 6. Positive mechanical engagement shall be as defined in 2.12. Spring forces may be used only to close the device and to prevent the effects of vibration from causing component parts of the device to move to positions where the device may open or disengage. The failure or omission of any one single spring shall not allow the complete device to open or disengage.^[SP11]
- 4.6 Every device or component shall be accompanied by installation and operating instructions giving sufficient information for any competent person to be able to install it correctly on the vehicle and operate it properly. In the case of devices and components supplied for original equipment fitting by a vehicle manufacturer or bodybuilder, installation instructions may be dispensed with, but the vehicle manufacturer or bodybuilder will be responsible for ensuring that the vehicle operator is supplied with the necessary instructions for correct operation of the coupling device or component.
- 4.7 For other non-standard miscellaneous coupling devices or components of Class s, the relevant requirements in annexes 5 and 6 for the closest standard or non-standard device or component shall be used.

Draft: ECE-R XXX

Testing: Mechanical coupling devices for agricultural vehicles

Last updated: 21 July 2011

4.8 Coupling devices on towed vehicles for connection to towing vehicles shall not be capable of rotating about the vehicle's longitudinal axis. [SP12]

4.9 The maximum vertical load for coupling devices on the rear of a tractor may not exceed 4000 daN. Quick height-adjustable towing devices in the latching rail may not exceed 3000 daN. A maximum of 2000 daN is permissible above the centre of the drilling pattern for mounting or the power take-off. [SP13]
Vertical loads in excess of 4000 daN are only permissible for coupling devices which are mounted between the axles. [SP14].

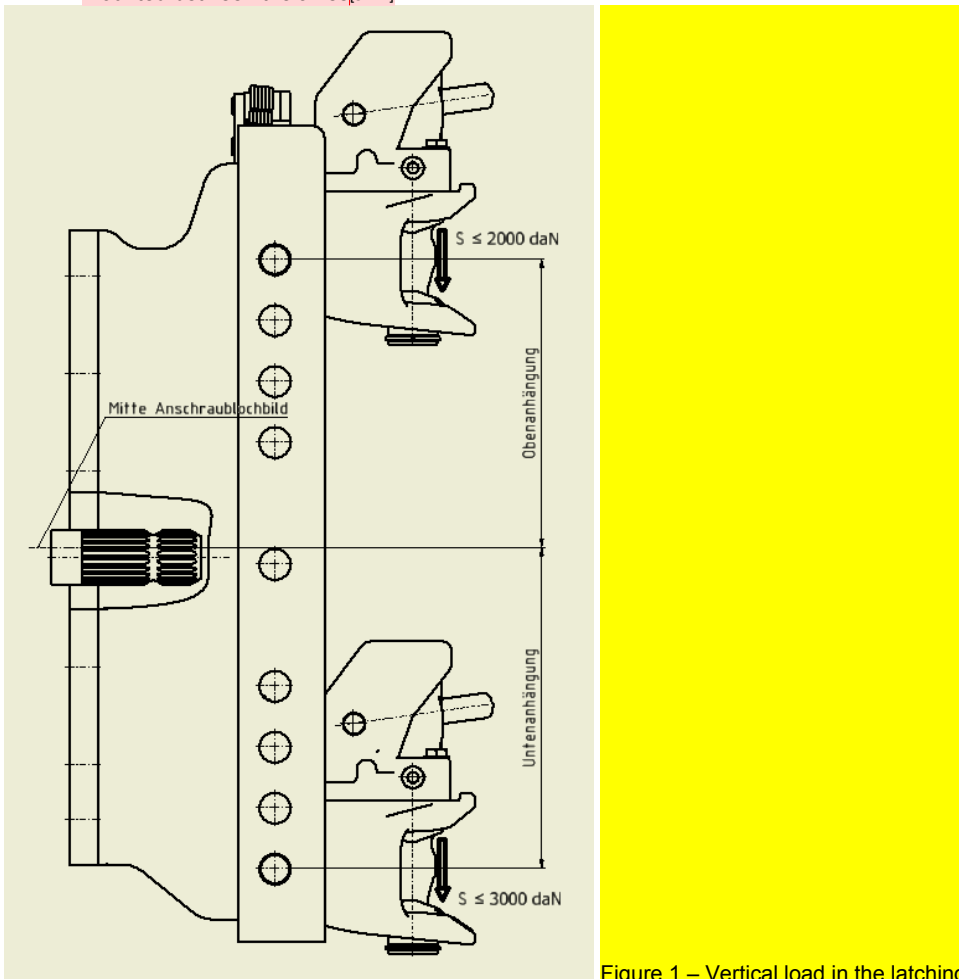

Figure 1 – Vertical load in the latching

rail

4.10 Quick height-adjustable towing devices with no power assistance may not exceed a mass of 35 kg.

5 General requirements for vehicles fitted with a mechanical coupling device or component

5.1 The mechanical coupling device or component fitted to the vehicle shall be approved in accordance with the requirements of paragraphs 3 and 4 and annexes 5 and 6 of this Regulation. This sentence does not make any sense to me. [SP15]

Draft: **ECE-R XXX**

Testing: Mechanical coupling devices for agricultural vehicles

Last updated: 21 July 2011

5.2 Operating instructions shall be provided for use of the coupling device or component which shall contain any special instructions for operations which are different from those normally associated with the type of coupling device or component and instructions for coupling and uncoupling with different modes of operation, for example, at various angles between the towing and towed vehicles. Each vehicle shall be accompanied by these operating instructions.

6 Markings

6.1 Mechanical coupling devices and components submitted for approval shall bear the trade name or mark of the manufacturer or applicant.

6.2 There shall be a sufficiently large space for application of the approval mark referred to in paragraph 7.5 and shown in annex 3. This space shall be shown on the drawings referred to in paragraph 3.2.2.

6.3 Adjacent to the approval mark referred to in paragraphs 7.2 and 7.5, the mechanical coupling device or component shall be marked with the class of coupling as defined in paragraph 2.6 and the relevant characteristic values as defined in paragraph 3.2.3 and shown in annex 4. The position of these markings shall be shown on the drawings referred to in paragraph 3.2.2.

6.4 All markings shall be permanent and be legible when the device or component is installed on the vehicle.

7 Approval

7.1 If the sample(s) of a type of mechanical coupling device or component meets (meet) the requirements of this Regulation, approval shall be granted subject to the requirements of paragraph 10 being satisfactorily met.

7.2 An approval number shall be assigned to each type approved. Its first two digits (at present 00) shall indicate the series of amendments incorporating the most recent major technical amendments made to the Regulation at the time of issue of the approval. The same Contracting Party may not assign the same approval number to any other type of device or component referred to in this Regulation.

7.3 Notice of approval or of extension, refusal or withdrawal of approval or of production definitely discontinued, relating to a type of mechanical coupling device or component approved pursuant to this Regulation, shall be communicated to the Parties to the 1958 Agreement applying this Regulation, by means of a communication form conforming to the model in either annex 1 or annex 2 to this Regulation.

7.4 In addition to the mark prescribed in paragraph 7.1, there shall be affixed to every mechanical coupling device or component approved under this Regulation, in the space referred to in paragraph 7.2, an approval mark as described in paragraph 7.5.

7.5 The approval mark shall be an international approval mark comprising:

7.5.1 a circle surrounding the letter "E" followed by the distinguishing number of the country which has granted approval:

(1 for Germany, 2 for France, 3 for Italy, 4 for the Netherlands, 5 for Sweden, 6 for Belgium, 7 for Hungary, 8 for the Czech Republic, 9 for Spain, 10 for Serbia and Montenegro, 11 for the United Kingdom, 12 for Austria, 13 for Luxembourg, 14 for Switzerland, 15 (vacant), 16 for Norway, 17 for Finland, 18 for Denmark, 19 for Romania, 20 for Poland, 21 for Portugal, 22 for the Russian Federation, 23 for Greece, 24 for Ireland, 25 for Croatia, 26 for Slovenia, 27 for Slovakia, 28 for Belarus, 29 for Estonia, 30 (vacant), 31 for Bosnia and Herzegovina, 32 for Latvia, 33 (vacant), 34 for Bulgaria, 35 (vacant), 36 for Lithuania, 37 for Turkey, 38 (vacant), 39 for Azerbaijan, 40 for The former Yugoslav Republic of Macedonia, 41 (vacant), 42 for The European Community (Approvals are granted by its Member States using their respective ECE symbol), 43 for Japan, 44 (vacant), 45 for Australia, 46 for Ukraine, 47 for South Africa, 48 for New Zealand, 49 for Cyprus, 50 for Malta and 51 for the Republic of Korea. Subsequent numbers will be assigned to other countries in the chronological order in which they ratify or accede to the "Agreement concerning the Adoption of Uniform Technical Prescriptions for Wheeled Vehicles, Equipment and Parts which can be Fitted and/ or

Draft: **ECE-R XXX**

Testing: Mechanical coupling devices for agricultural vehicles

Last updated: 21 July 2011

be Used on Wheeled Vehicles and the Conditions for Reciprocal Recognition of Approvals Granted on the Basis of these Prescriptions", and the numbers thus assigned shall be communicated by the Secretary-General of the United Nations to the Contracting Parties to the Agreement.

7.5.2 the approval number prescribed in paragraph 7.2.;

7.5.3 the approval mark and approval number shall be arranged as shown in the example in annex 3.

8 Modifications to the mechanical coupling device or component, or to the vehicle and extension of approval

8.1 Any modification to the type of mechanical coupling device or component, or to the vehicle type as defined in paragraph 2.10 shall be notified to the type approval authority or technical service which granted the approval. The type approval authority or technical service may then either:

8.1.1 consider that the modifications are unlikely to have any appreciable adverse effect and that in any case the device, component or vehicle still conforms to requirements; or

8.1.2 require a further test report.

8.2 Confirmation of, or refusal of approval, specifying the modification, shall be communicated by the procedure prescribed in paragraph 8.3 to the Contracting Parties applying this Regulation.

8.3 The type approval authority or technical service issuing an extension of approval shall assign a series number for such an extension and shall inform the other Contracting Parties applying this Regulation by the procedure prescribed in paragraph 7.3.

9 Conformity of production procedures

The conformity of production procedures shall comply with those set out in Appendix 2 to the Agreement (E/ECE/324-E/ECE/TRANS/505/Rev.2), with the following requirements:

9.1 The holder of the approval must ensure that results of conformity of production tests are recorded and that the annexed documents remain available for a period determined in agreement with the approval authority or technical service. This period must not exceed 10 years counted from the time when production is definitely discontinued.

9.2 The type approval authority or technical service which has granted type approval may at any time verify the conformity control methods applied in each production facility. The normal frequency of these verifications shall be once every two years.

9.3 If static or dynamic testing as defined in annex 6 is carried out in order to verify conformity of production, the test force may be reduced to 95% of its original value. The devices tested will be evaluated in accordance with paragraphs 1.2 and 1.3 in annex 6.

Note: This point requires further discussion. Is there another option for catching the variability of component strength during CoP verification?

10 Penalties for non-conformity of production

10.1 The approval granted in respect of a type of mechanical coupling device or component pursuant to this Regulation may be withdrawn if the requirements are not complied with or if a device or component bearing the approval mark does not conform to the type approved.

10.2 If a Contracting Party to the Agreement applying this Regulation withdraws an approval it has previously granted, it shall forthwith so notify the other Contracting Parties applying this Regulation by means of a communication form conforming to the model in either annex 1 or annex 2 to this Regulation.

Draft: **ECE-R XXX**

Testing: Mechanical coupling devices for agricultural vehicles

Last updated: 21 July 2011

11 Production definitely discontinued

If the holder of the approval completely ceases to manufacture a type of mechanical coupling device or component approved in accordance with this Regulation, he shall so inform the type approval authority or technical service which granted the approval. Upon receiving the relevant communication, that type approval authority or technical service shall inform thereof the other Contracting Parties to the 1958 Agreement applying this Regulation by means of a communication form conforming to the model in either annex 1 or annex 2 to this Regulation.

12 Transitional provisions

[to be completed]

13 Names and addresses of technical services responsible for approval tests and of administrative departments

13.1 The Contracting Parties to the 1958 Agreement applying this Regulation shall communicate to the United Nations Secretariat the names and addresses of the technical services responsible for conducting approval tests and of the administrative departments which grant approval and to which forms certifying approval or extension or refusal or withdrawal of approval, or production definitely discontinued, issued in other countries, are to be sent.

Draft: ECE-R XXX

Testing: Mechanical coupling devices for agricultural vehicles
Last updated: 21 July 2011

Annex 1
Communication

(maximum format: A4 (210 mm x 297 mm))

issued by: (Name of administration)

.....

.....

concerning ¹ approval granted
approval extended
approval refused
approval withdrawn
production definitely discontinued
of a type of mechanical coupling device
or component
pursuant to Regulation No. XXX

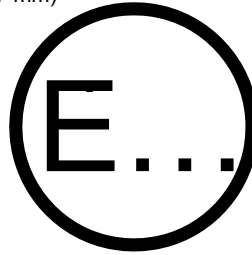

2

Approval No. Extension No.

- 1 Trade name or mark of the device or component
 - 2 Manufacturer's name for the type of device or component
 - 3 Manufacturer's name and address
 - 4 If applicable, name and address of the manufacturer's representative
 - 5 Alternative supplier's names or trademarks applied to the device or component
 - 6 Name and address of company or body taking responsibility for the conformity of production
 - 7 Submitted for approval on
 - 8 Technical service responsible for conducting approval tests ...
 - 9 Brief description
 - 9.1 Type and class of device or component
 - 9.2 Characteristic values
DkN D_ckN S daN
[SP16]C kg
V_{max} km/h [SP17]
- or alternative characteristic value combinations.
- 10 Instructions for the attachment of the coupling device or component to the vehicle and photographs or drawings of the mounting points given by the vehicle manufacturer
 - 11 Information on the fitting of any special reinforcing brackets or plates or spacing components necessary for the attachment of the coupling device or component

¹ Strike out what does not apply.

² Distinguishing number of the country which has granted/extended/refused/withdrawn approval (see approval provisions in the Regulation).

Draft: **ECE-R XXX**

Testing: Mechanical coupling devices for agricultural vehicles
Last updated: 21 July 2011

- 12 Additional information
- 13 Date of test report
- 14 Number of test report
- 15 Approval mark position
- 16 Reason(s) for extension of approval
- 17 Approval granted/extended/refused/withdrawn²⁾:
- 18 Place
- 19 Date
- 20 Signature
- 21 The list of documents deposited with the Administration Service which has granted approval is annexed to this communication and may be obtained on request.

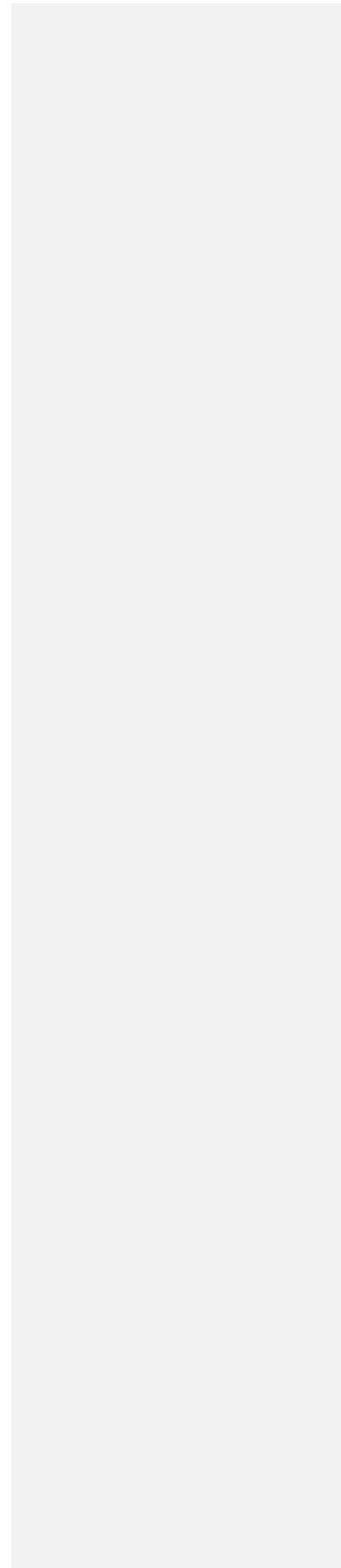

Draft: ECE-R XXX

Testing: Mechanical coupling devices for agricultural vehicles
Last updated: 21 July 2011

Annex 2

Assignment of mechanical coupling devices of towing vehicles or self-propelled machines and towed vehicles^[SP18]

Coupling device on the towing vehicle	Coupling device on the towed vehicle
Class a	Class b
Class c	Class d1 Class d2
Class g	Class d3 Class d4
Class h	Class d3
Class s for tractor drawbars as defined in ISO 6489-3 only	Class d3, Class s (coupling rings for tractor drawbars as defined in ISO 21244)

Draft: ECE-R XXX

Testing: Mechanical coupling devices for agricultural vehicles
Last updated: 21 July 2011

Annex 3

Example of an arrangement of the approval mark

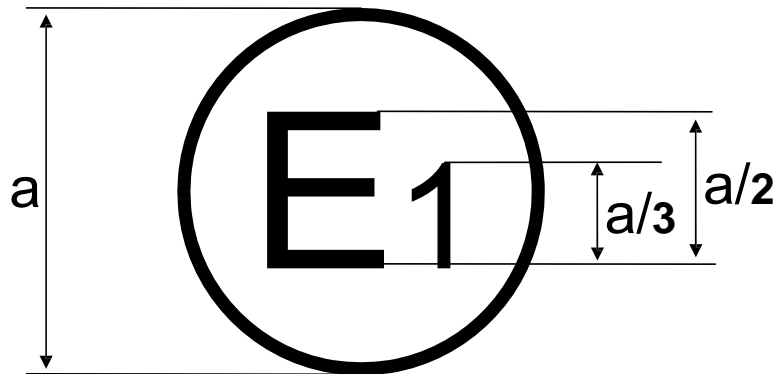

XXX R - 00 2405 $\frac{a}{3}$

$a \geq 8 \text{ mm}$

The mechanical coupling device bearing the approval mark shown above is a device or component approved in Germany (E 1), under approval number 2405, meeting the requirements of the 00 series of amendments to this Regulation.

Note: The approval number and additional symbols shall be placed close to the circle and either above or below the letter 'E', or to the right or left of that letter. The digits of the approval number shall be on the same side of the letter 'E' and face in the same direction. The use of Roman numerals as approval numbers should be avoided so as to prevent any confusion with other symbols.

Draft: ECE-R XXX

Testing: Mechanical coupling devices for agricultural vehicles
Last updated: 21 July 2011

Annex 4

Examples of arrangements of marking of the characteristic values

- 1 All mechanical coupling devices or components shall be marked with the class of the device or component. In addition there shall be marking to indicate the capacity in terms of characteristic values as defined in paragraph 2.10 of this Regulation.
- 1.1 The height of all letters and numbers shall be not less than those of the approval number, that is $a/3$ where a is 8 mm.
- 1.2 The characteristic values applicable to each device or component which are to be marked are as shown in the table below - see also paragraph 7.3 of this Regulation:

Table
1^[SP19]

Characteristics values which are to be marked on coupling devices or components

Description of mechanical coupling device or component	Characteristic values to be marked					
	Class	D	D _c	S	C	V _{max}
Coupling balls 80	X	X	X	X	-	-
Ball-shaped scrapers 80	X	X	X	X	-	-
Clevis-type couplings	X	X	X	X	-	-
Hook-type couplings	X	X	X	X	-	-
Tractor drawbars	X	X	X	X	-	-
Piton-type couplings	X	X	X	X	-	-
Coupling rings	X	X	X	X	-	-
Drawbars	X	X	X	X	X	X

Examples: a80-2 D130 D_c90 S2000 would identify a standard coupling ball 80 of Class a80-2 with a maximum D value of 130 kN, a maximum permitted D_c value of 90 kN and a maximum permitted static vertical imposed load of 2,000 kgf.

Annex
5_[SP20]

Requirements for mechanical coupling devices or components

1 Coupling balls 80 and keeper plates

1.1 General requirements for coupling balls 80

1.1.1 All coupling balls 80 and keeper plates shall be designed such that the coupling balls satisfy the tests prescribed in paragraph 3.1 of annex 6 and keeper plates satisfy the tests prescribed in paragraph 3.3.5 of annex 6.

1.1.2 Coupling balls 80 of Class a shall conform to Figure 1 in external shape and external dimensions. The position of the keeper plate is shown in Figure 2.

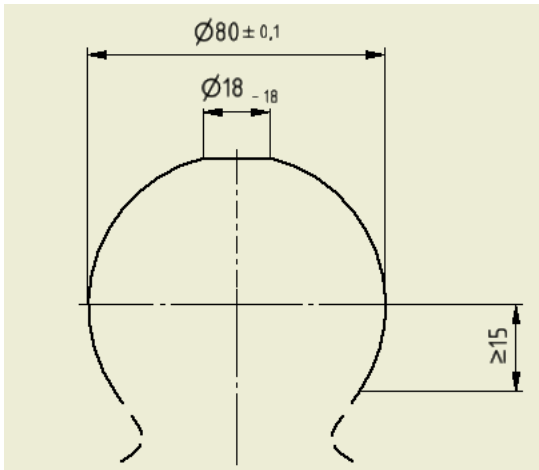

Figure 1 – Ball dimensions

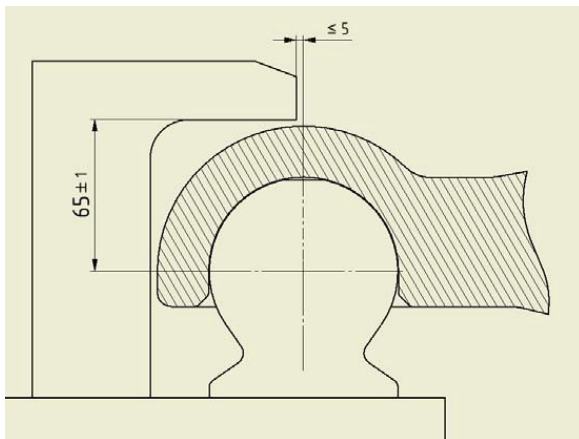

Figure 2 – Keeper plate dimensions

1.1.3_[SP21] The coupling balls 80 shall have at least the following angles of articulation, which do not have to be reached simultaneously:

Draft: ECE-R XXX

Testing: Mechanical coupling devices for agricultural vehicles

Last updated: 21 July 2011

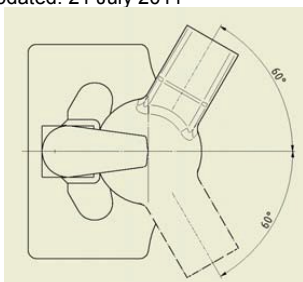

Vertical axis: $\pm 60^\circ$

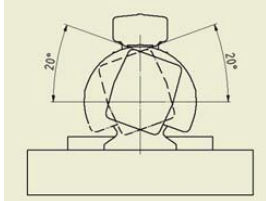

Longitudinal axis: $\pm 20^\circ$

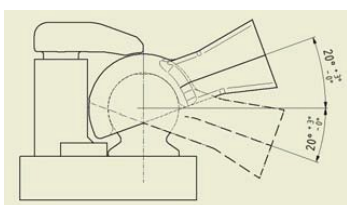

Transverse axis: $\pm 20^\circ$

1.2 Coupling balls 80 with standard flange-type bolted fixing of Class a80-1

1.2.1 [SP22] In addition, coupling balls 80 of Class a80-1 shall have the following principal dimensions:

Subclass	a [mm]	b [mm]	c [mm]	D [mm]	e [mm]
a80-1.3	120	55	15	155	90
a80-1.4	140	80	17	180	120
a80-1.5	160	100	21	200	140

Draft: ECE-R XXX

Testing: Mechanical coupling devices for agricultural vehicles
 Last updated: 21 July 2011

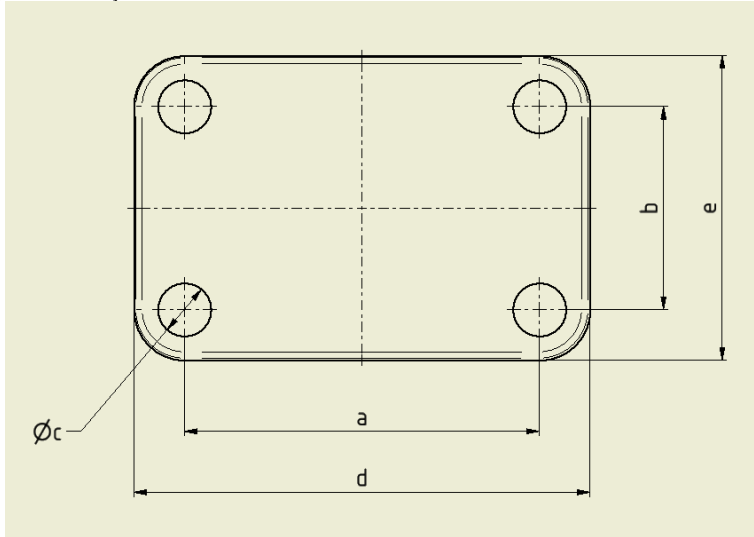

Figure 3 – Dimensions of standard flange

1.2.2 The flange may also be mounted so that it is rotated by an angle of 90° to the visual representation if this installation position was considered when performing the tests specified in annex 6 and is described in the installation and operating instructions.

1.3 Coupling balls 80 with standard latching rail plate (coupling mount) of Class a80-2

1.3.1 [SP23] In addition, coupling balls 80 of Class a80-2 shall have the following principal dimensions:

Subclass	Guide width in the towing bracket [mm]	a Latching rail plate width [mm]	b Locking pin diameter [mm]	c Latching rail guide width [mm]	d Minimum guide depth [mm]
a80-2.1	330	329	25	32	20
a80-2.2	336	335	22	30	20
a80-2.3	390	389	25	32	20
a80-2.4	200	199	22	30	20

a80 2.1 and a80 2.3 are to be preferred. a80 2.4 is preferred for track widths of 1150 mm or less.

Draft: **ECE-R XXX**

Testing: Mechanical coupling devices for agricultural vehicles

Last updated: 21 July 2011

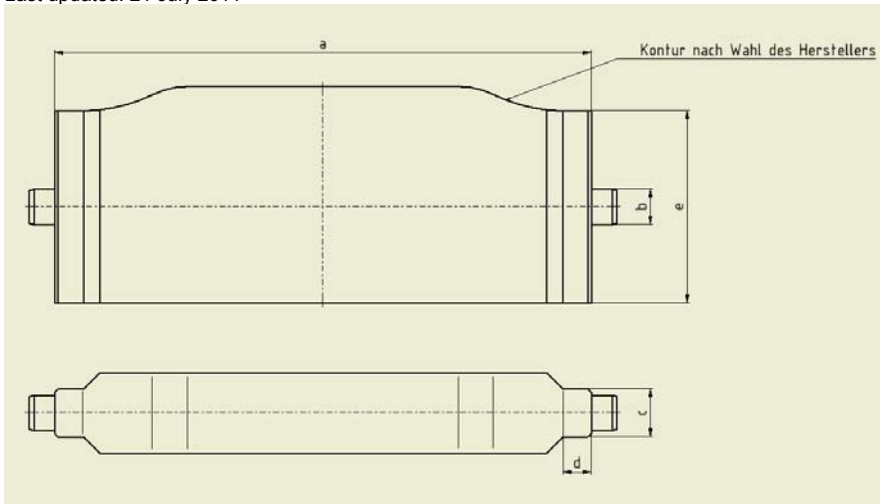

Figure 4 – Dimensions of standard latching rail plate

2 Ball-shaped scrapers 80

2.1 General requirements for ball-shaped scrapers 80

2.1.1 All ball-shaped scrapers 80 shall be designed so that they are able to satisfy the tests given in paragraph 3.2 of annex 6.

2.1.2 Ball-shaped scrapers 80 of Class b shall conform to Figure 5 in external shape and external dimensions.

Draft: ECE-R XXX

Testing: Mechanical coupling devices for agricultural vehicles
 Last updated: 21 July 2011

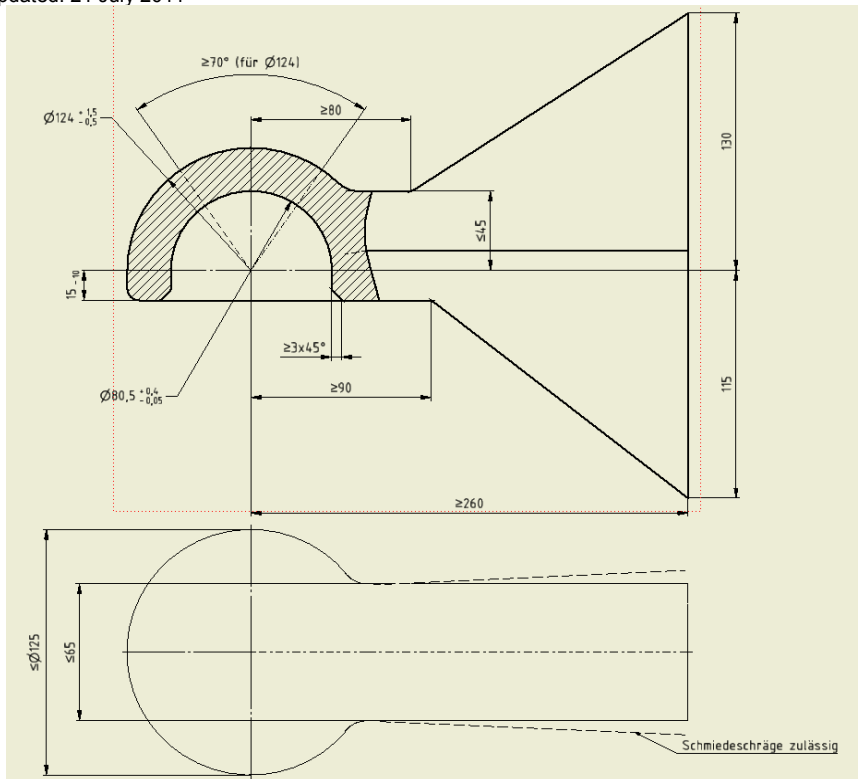

Figure 5 – Dimensions of standard ball-shaped scraper

2.2 Ball-shaped scrapers 80 with standard welding shank of Class b80-1

2.2.1 In addition, ball-shaped scrapers 80 of Class b80-1 shall have the following dimensions:

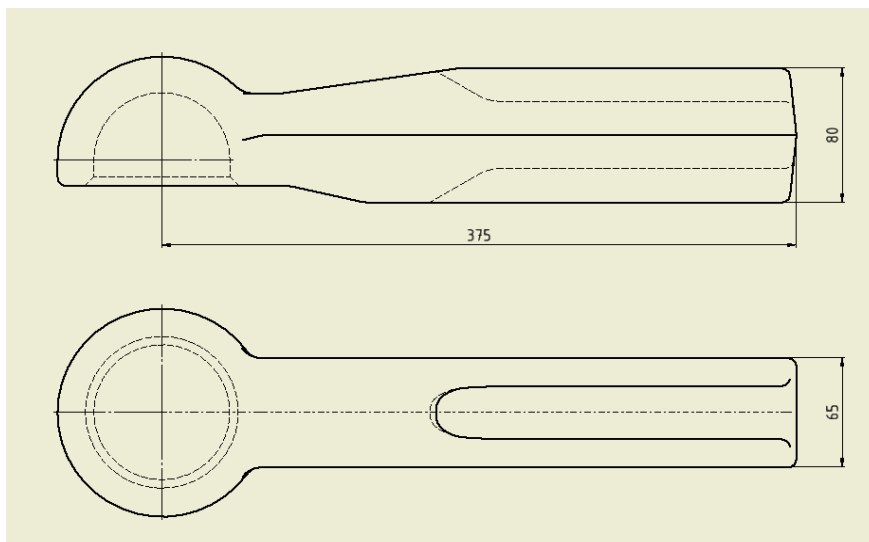

Figure 6 – Principal dimensions of standard ball-shaped scraper b80-1

2.4. Ball-shaped scrapers 80 with standard flange of Class b80-2

Draft: ECE-R XXX

Testing: Mechanical coupling devices for agricultural vehicles

Last updated: 21 July 2011

2.4.1 In addition, ball-shaped scrapers 80 of Class b80-2 shall have the following principal dimensions:^[SP26]

Subclass	a [mm]	b [mm]	c [mm]	d [mm]	e [mm]	F [mm]
b80-2.1	100	-	110	17	154	154
b80-2.2	100	110	110	17	154	154
b80-2.3	130	130	130	21	205	195
b80-2.4	145	145	145	21	205	195
b80-2.5	145	160	145	21	205	195

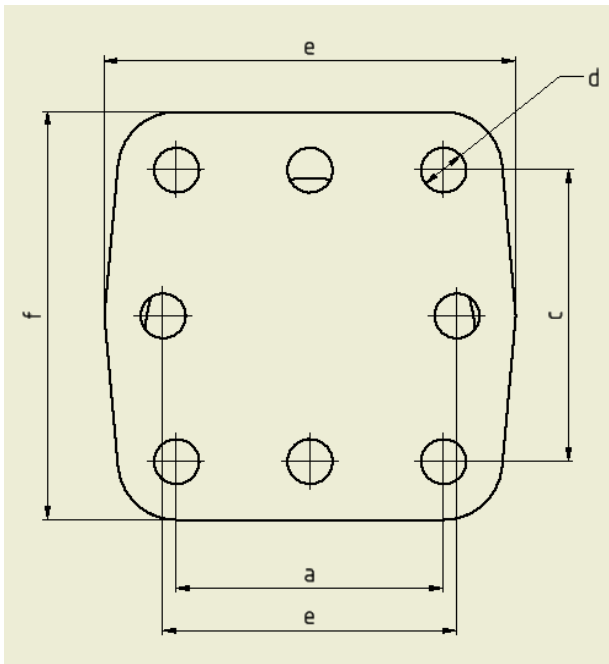

Figure 7 – Dimensions of standard flange

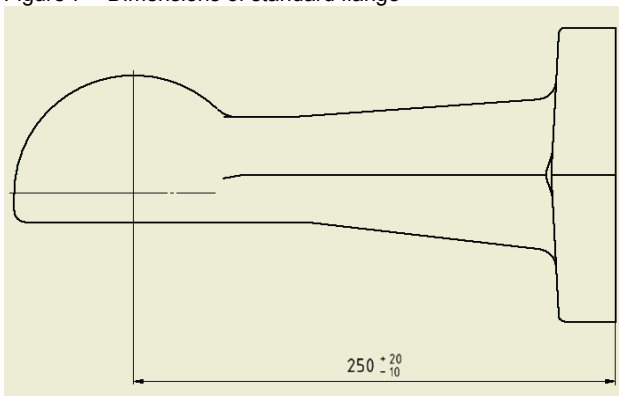

Figure 8 – Principal dimensions of standard ball-shaped scraper b80-2

Draft: ECE-R XXX

Testing: Mechanical coupling devices for agricultural vehicles
Last updated: 21 July 2011

2.5. Ball-shaped scrapers 80 with standard horizontal flange of Class b80-3

2.5.1. In addition, ball-shaped scrapers 80 of Class b80-3 shall have the following dimensions:

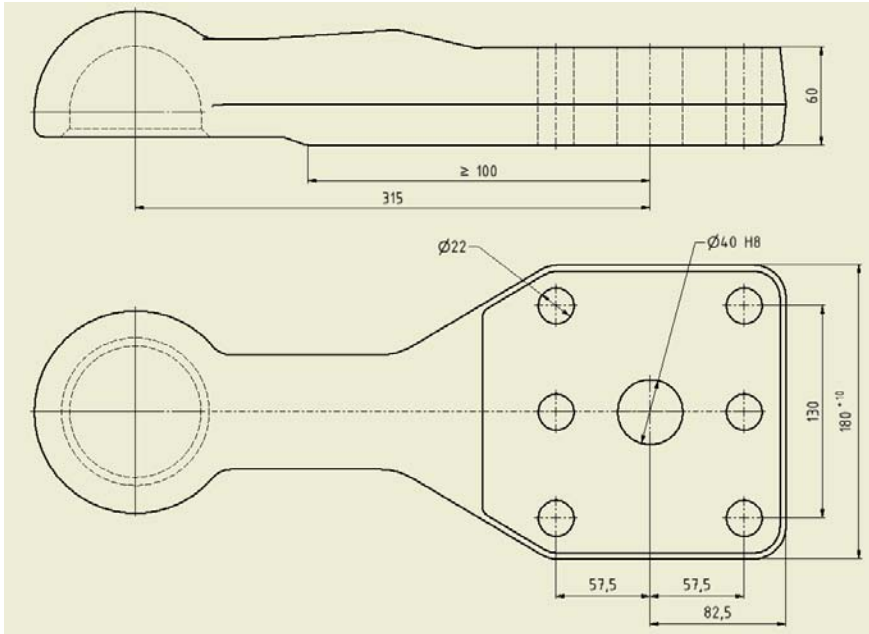

Figure 9 – Principal dimensions of standard ball-shaped scraper b80 3

3 Clevis-type couplings

3.1 General requirements for clevis-type couplings

3.1.1 All clevis-type couplings shall be designed so that they satisfy the tests prescribed in paragraph 3.3.1 of annex 6 and locking devices so that they satisfy the tests prescribed in paragraph 3.3.1.3 of annex 6.

3.1.2 Clevis-type couplings of Class c shall conform to Figures 10, 11, ~~and 12, 12a and 12b~~ in external shape and external dimensions. ~~For all classes, the jaw height 2) (Note: I don't think so) shall be present over at least half of the jaw width.~~ [SP27]

3.1.3 Requirements:

Clevis-type couplings shall be designed **(better: can be designed)** for a maximum D and D_c value of up to 120 kN and a maximum static vertical load of **2000-3000 daN**. **Note: otherwise it sounds as if all clevis-type couplings have to attain these characteristic values**
For automatic coupling, Aafter coupling, the closed and locked position shall be clearly and conspicuously indicated externally by at least one control indicator.

3.1.4 Coupling and uncoupling of the coupling ring shall also be possible when the longitudinal axis of the coupling ring in relation to the centre line of the jaw:

- a) is rotated horizontally 50° to the right or left;
- b) is rotated vertically 6° up or down;
- c) is rotated axially 6° to the right or left.

Draft: ECE-R XXX

Testing: Mechanical coupling devices for agricultural vehicles
Last updated: 21 July 2011

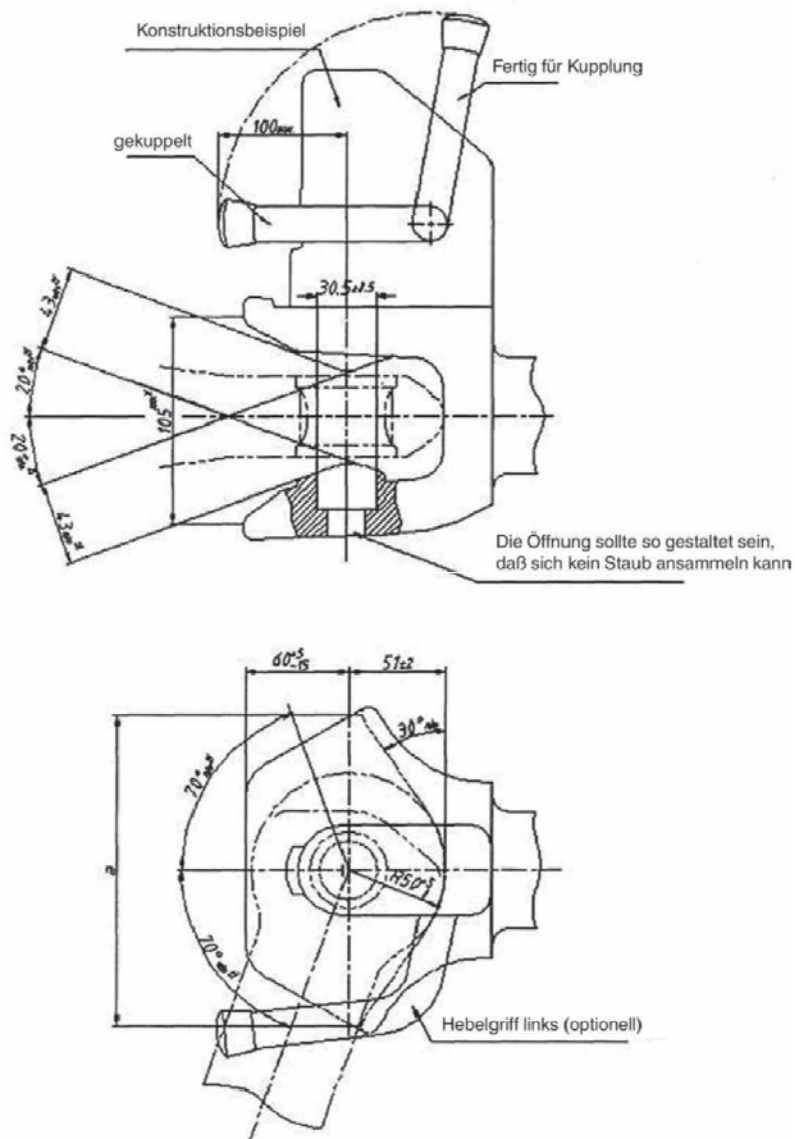

Figure 10 – Automatic trailer coupling with cylindrical pin

Draft: ECE-R XXX

Testing: Mechanical coupling devices for agricultural vehicles
Last updated: 21 July 2011

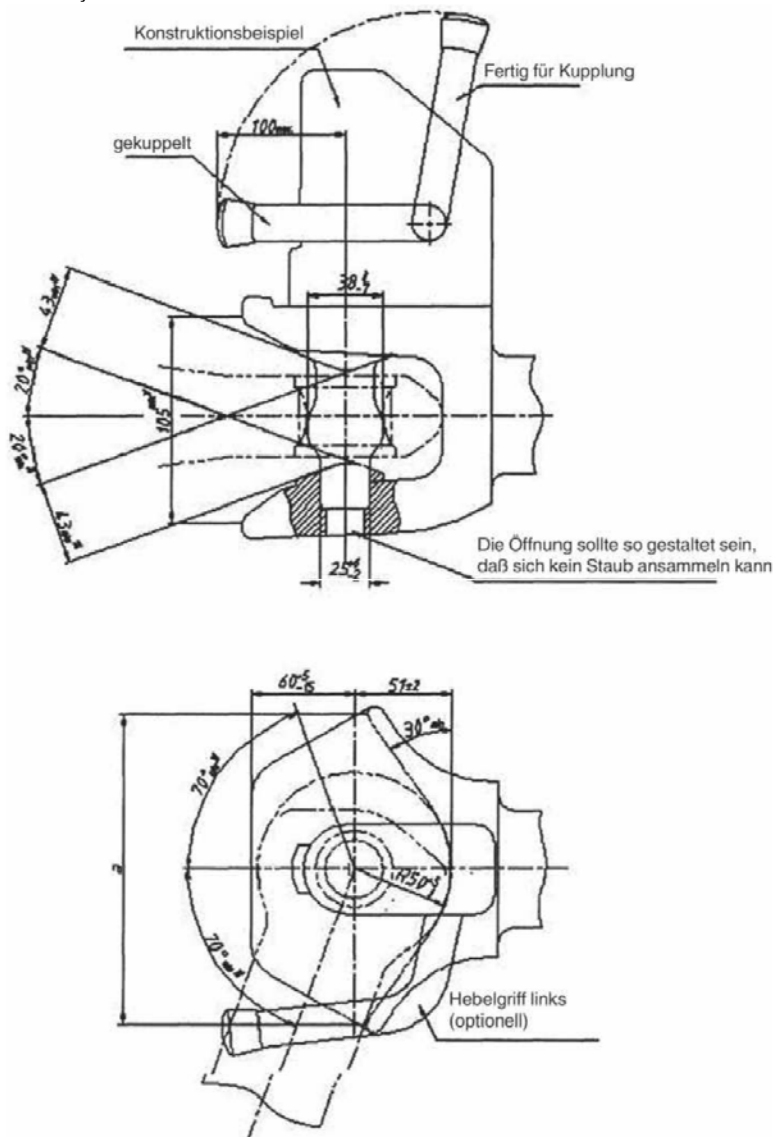

Figure 11 – Automatic coupling device with bulged pin

Draft: ECE-R XXX

Testing: Mechanical coupling devices for agricultural vehicles
Last updated: 21 July 2011

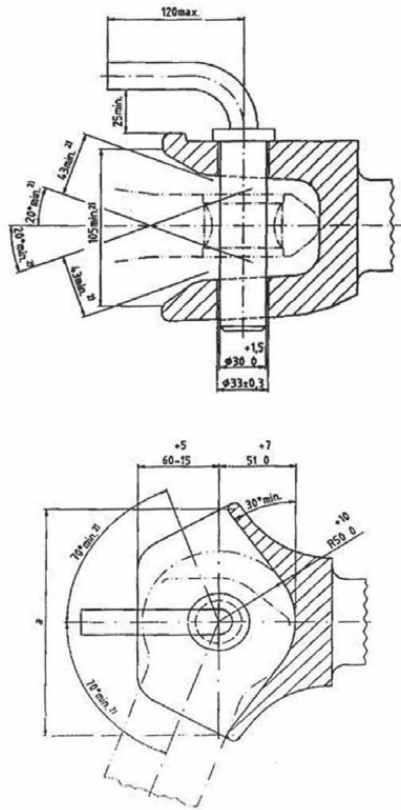
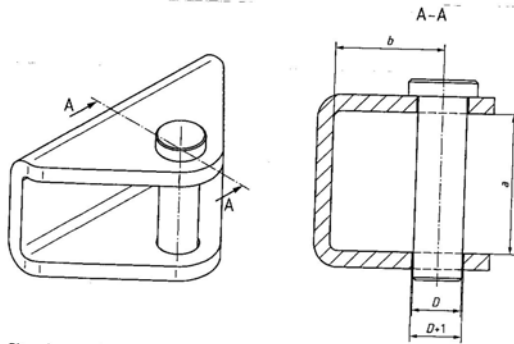

Figure 12 – Non-automatic trailer coupling with cylindrical pin



NOTE Dimensions are given in Table 1.

Figure 1 — Non-swivel clevis coupling

2

© ISO 2011 – All rights reserved

Table 1 — Shapes and dimensions of trailer or implement clevis couplings

Vertical load <i>S</i> kg	D value <i>D</i> kN	Shape	Dimension mm		
			<i>D</i> ±0,5	<i>a</i> min.	<i>b</i> min.
≤1 000	≤35	w	18	50	40
≤2 000	≤90	x	28	70	55
≤3 000	≤120	y	43	100	80
≤3 000	≤120	z	50	110	95



figure 12a

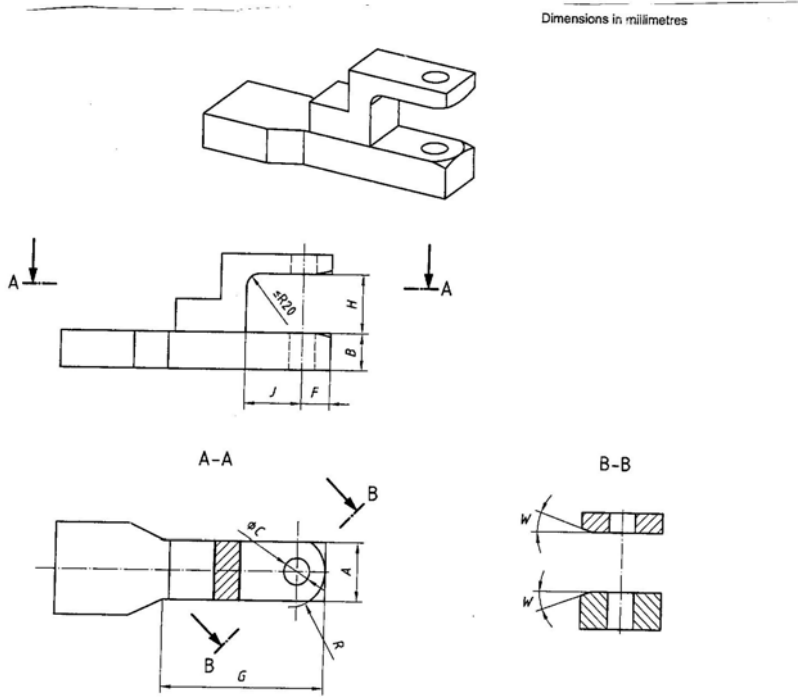

Figure 2 — Tractor drawbar and clevis

4

© ISO 2004 — All rights reserved



[figure 12b](#)

Draft: **ECE-R XXX**

Testing: Mechanical coupling devices for agricultural vehicles
Last updated: 21 July 2011

3.1.3 Clevis-type couplings shall have the following angles of articulation (see also Figures 1.1–1.3):

- Vertical axis: ± 70 ~~60~~°
- Transverse axis: ± 20 °
- Longitudinal axis: ± 20 °

3.2 Clevis-type couplings with standard flange-type bolted fixing of Class c40-1

3.2.1 In addition, clevis-type couplings of Class c40-1 shall have the following principal dimensions: ^[SP28]

Subclass	a [mm]	b [mm]	c [mm]	d [mm]	e [mm]
c40-1.3	120	55	15	155	90
c40-1.4	140	80	17	180	120
c40-1.5	160	100	21	200	140

Draft: ECE-R XXX

Testing: Mechanical coupling devices for agricultural vehicles
Last updated: 21 July 2011

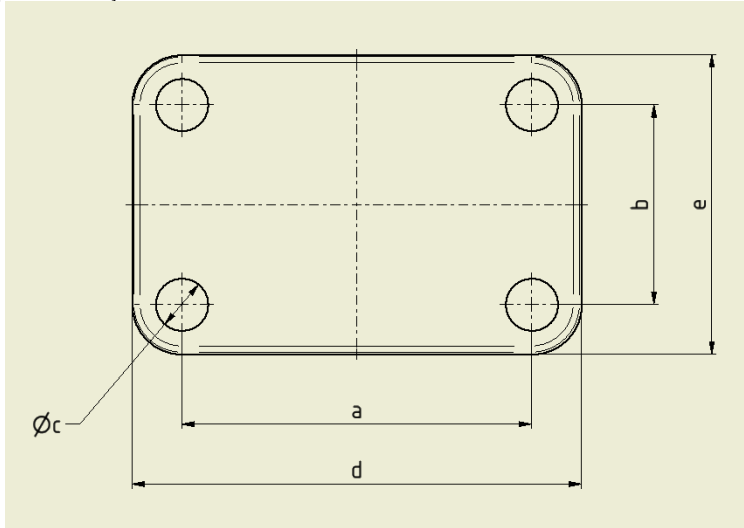

Figure 13 – Dimensions of standard flange

3.2.2 The flange may also be mounted so that it is rotated by an angle of 90° to the visual representation if this installation position was considered when performing the tests specified in annex 6 and is described in the installation and operating instructions.

3.3 Clevis-type couplings with standard latching rail plate (coupling mount/interior component) of Class c40-2

3.3.1^[SP29] In addition, clevis-type couplings of Class c40-2 shall have the following principal dimensions:

Subclass	Guide width in the towing bracket [mm]	a Latching rail plate width [mm]	b Locking pin diameter [mm]	c Latching rail guide width [mm]	d Minimum guide depth [mm]
c40-2.1	330	329	25	32	20
c40-2.2	336	335	22	30	20
c40-2.3	390	389	25	32	20
c40-2.4	200	199	22	30	

Draft: ECE-R XXX

Testing: Mechanical coupling devices for agricultural vehicles
Last updated: 21 July 2011

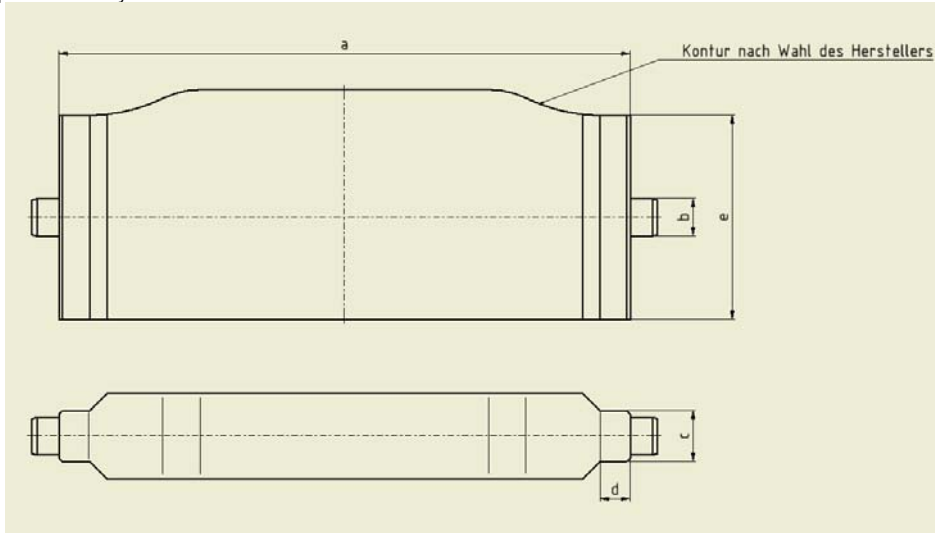

Figure 14 – Dimensions of standard latching rail plate

4 Coupling rings

4.1 Coupling rings d1-40

4.1.1 General requirements for coupling rings d1-40^[SP30]

All coupling rings of Class d1-40 shall be designed so that they are able to satisfy the tests given in paragraph 3.4 of annex 6.

Coupling rings shall conform to Figure 15 in the external shape and external dimensions of the ring.

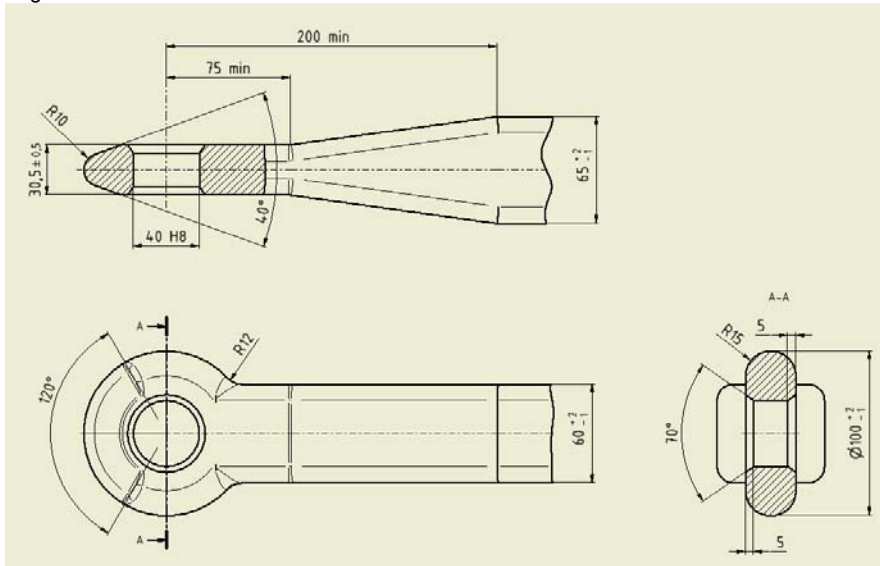

Figure 15 – Principal dimensions of standard coupling rings d1-40 and d1-40-1

Draft: ECE-R XXX

Testing: Mechanical coupling devices for agricultural vehicles
Last updated: 21 July 2011

- 4.1.2 Coupling rings of Class d1-40-1 with standard welding shank
Coupling rings of Class d1-40-1 shall conform to Figure 15 in dimensions 65 and 60 of the shank.
- 4.1.3 Coupling rings of Class d1-40-2 with standard straight shank
Coupling rings of Class d1-40-2 shall conform to Figure 16 in the dimensions of the shank bearing.



Bild 2.

Figure 16 – Dimensions of standard coupling ring d1-40-2

- 4.1.4 Coupling rings of Class d1-40-3
Coupling rings of Class d1-40-3 shall conform to Figure 17 in the dimensions of the flange.

Draft: ECE-R XXX

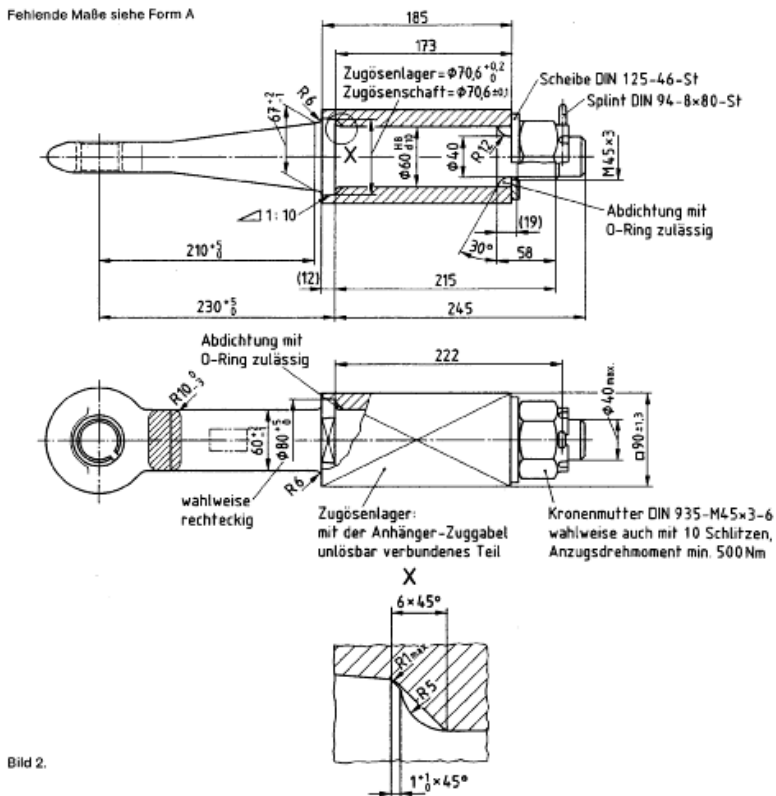
Testing: Mechanical coupling devices for agricultural vehicles
Last updated: 21 July 2011

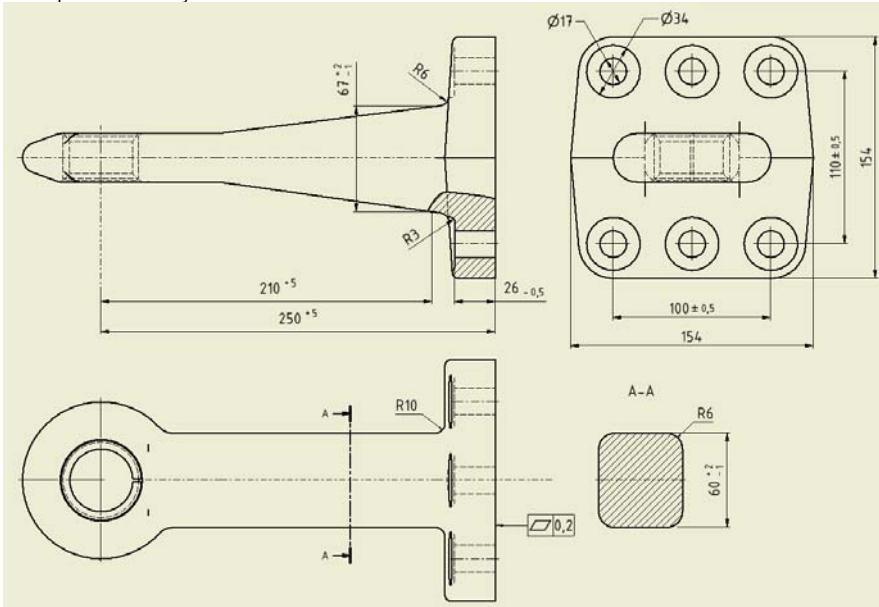

Figure 17 – Dimensions of standard coupling ring with standard flange d1-40-3

4.1.5 Sleeve 40_[SP31]

The sleeve must not be welded into the coupling ring. For coupling rings d1-40-1 and d1-40-2, slotted or non-slotted sleeves shall be used. For coupling ring d1-40-3, non-slotted sleeves shall be used. Sleeves shall be connected to the body of the coupling ring so that they cannot become loose during use. The design of the sleeve does not have to correspond to the visual representation, it must merely conform to the specified dimensions.

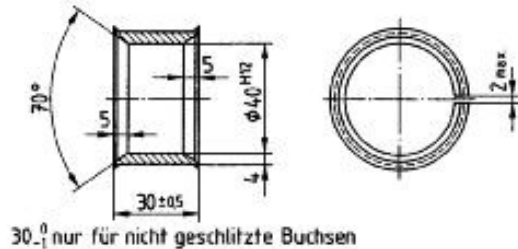

Figure 18 – Sleeve dimensions in the installed state

4.2 Coupling rings d2-40

4.2.1 General requirements for coupling rings d2-40

All coupling rings of Class d2-40 shall be designed so that they are able to satisfy the tests given in **xx** of annex 6. **This point is not present in annex 6!**

Coupling rings shall conform to Figure 19 in the external shape and external dimensions of the ring.

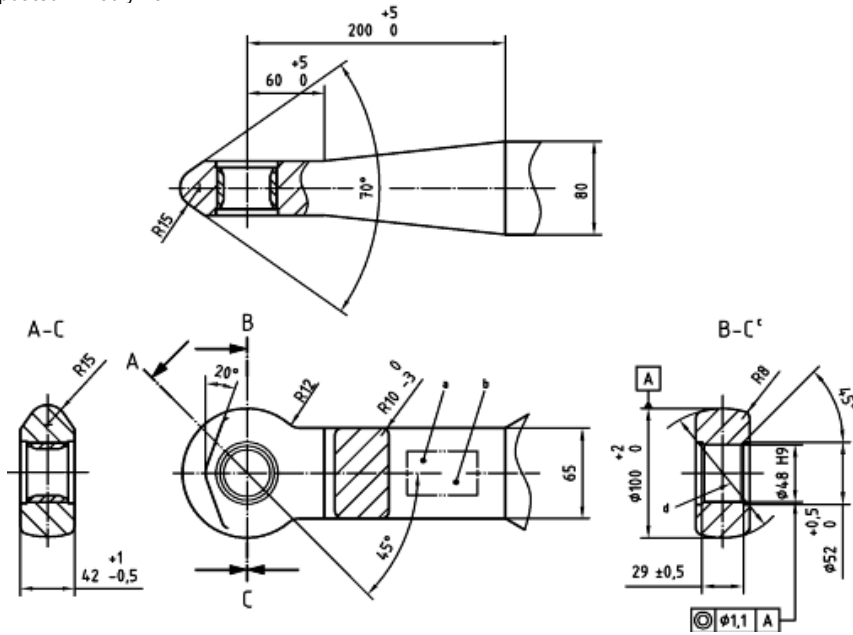

Figure 19 – Principal dimensions of standard coupling ring d2-40

4.2.2 Coupling rings of Class d2-40-1 with standard welding shank

In addition, coupling rings of Class d2-40-1 shall conform to shank dimensions 65 and 80.

4.2.3 Coupling rings of Class d2-40-3

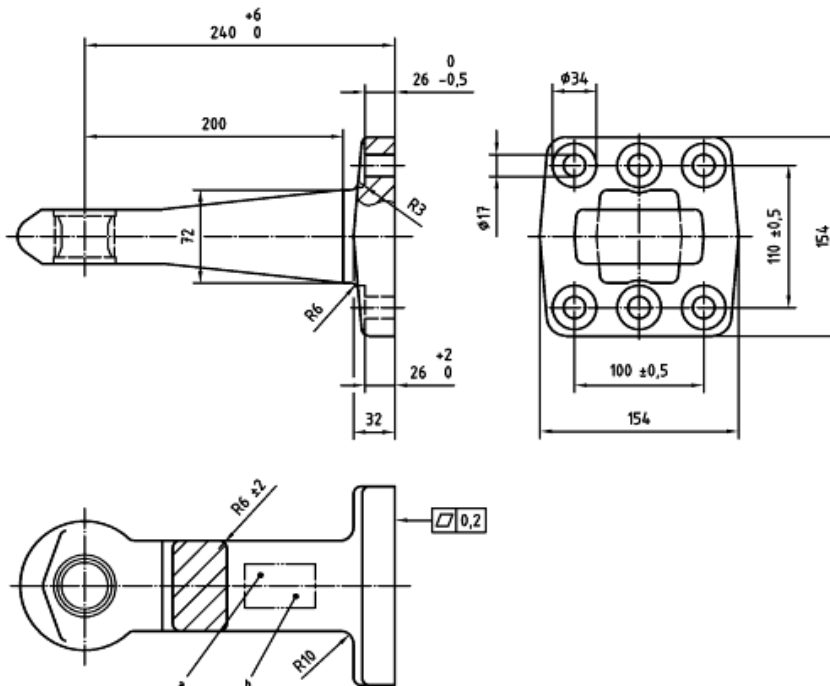

Figure 19 – Principal dimensions of standard coupling ring with standard flange d2-40-3

Draft: ECE-R XXX

Testing: Mechanical coupling devices for agricultural vehicles
Last updated: 21 July 2011

4.3 Coupling rings of Class d3-50-2

4.3.1 General requirements^[SP32]

All coupling rings of Class d3 shall be designed so that they are able to satisfy the tests given in **xx** of annex 6. **There is no point for d3.**

Coupling rings of Class d3 shall conform to Figure **xx** in external shape and external dimensions.

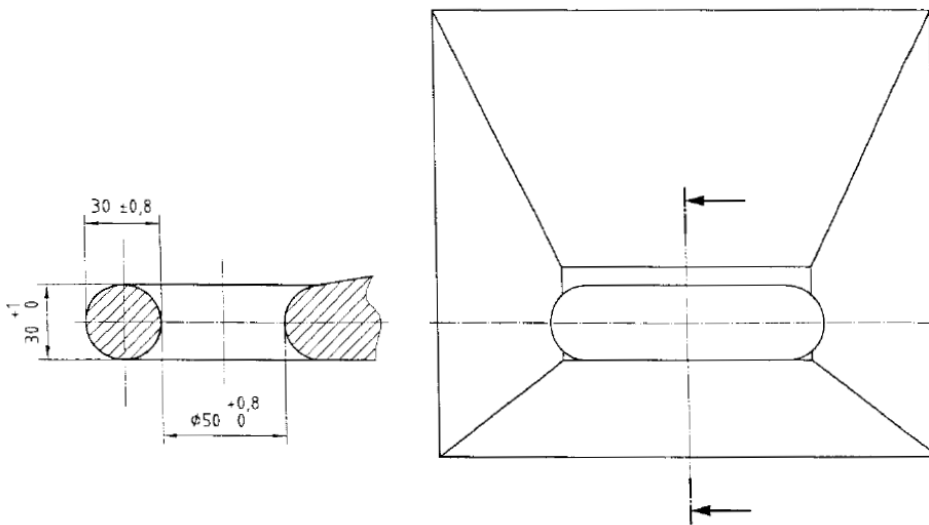

Figure 20 – Hitch ring 50

4.3.2 Hitch rings 50 with standard welding shank of Class d3-50-1

In addition, hitch rings of Class d3-50-1 shall have the following dimensions:

((insert image))

Figure 21 –

Draft: **ECE-R XXX**

Testing: Mechanical coupling devices for agricultural vehicles

Last updated: 21 July 2011

4.3.3 Hitch rings 50 with standard flange of Class d3-50-2

In addition, hitch rings of Class d3-50-2 shall have the following principal dimensions:^[SP33]

Subclass	a [mm]	b [mm]	c [mm]	d [mm]	e [mm]	F [mm]
d3-50-2.1	100	-	110	17	154	154
d3-50-2.2	100	110	110	17	154	154
d3-50-2.3	130	130	130	21	205	195
d3-50-2.4	145	145	145	21	205	195
d3-50-2.5	145	160	145	21	205	195

4.4 Coupling rings of Class d4

4.4.1 General requirements^[SP34]

All coupling rings of Class d4 shall be designed so that they are able to satisfy the tests given in **xx** of annex 6. **There is no point for d4**

Coupling rings of Class d4 shall conform to Figure **xx** in external shape and external dimensions.

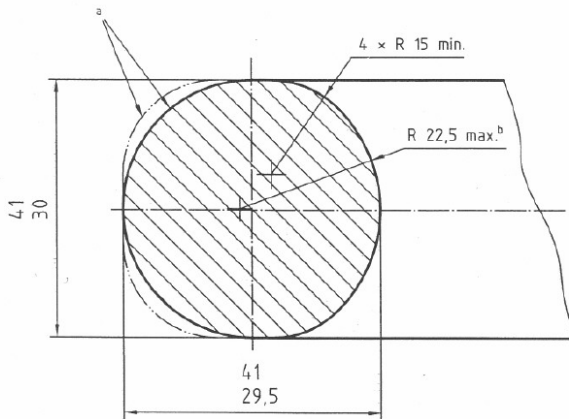

^a Alternative outer contour: outer radius 22.5 max. and 15 min. blend radius top and bottom, or min. top and bottom blend radius to flat outer surface.

^b Internal contour.

Figure 22 –

Draft: ECE-R XXX

Testing: Mechanical coupling devices for agricultural vehicles
 Last updated: 21 July 2011

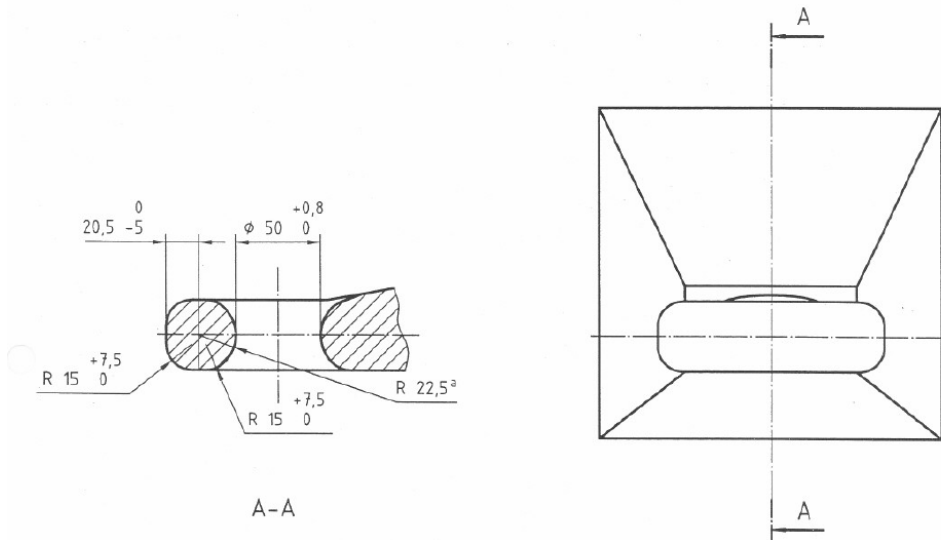

^a Internal contour.

Figure 23 –

4.4.2 Hitch rings 50 with standard welding shank of Class d4-50-1

In addition, hitch rings of Class d4-50-1 shall have the following dimensions:

Figure 24 – ((insert image))

4.4.3 Hitch rings 50 with standard flange of Class d4-50-2

In addition, hitch rings of Class d4-50-2 shall have the following principal dimensions:

Subclass	a [mm]	b [mm]	c [mm]	d [mm]	e [mm]	F [mm]
d4-50-2.1	100	-	110	17	154	154
d4-50-2.2	100	110	110	17	154	154
d4-50-2.3	130	130	130	21	205	195
d4-50-2.4	145	145	145	21	205	195
d4-50-2.5	145	160	145	21	205	195

5 Drawbars

5.1. Drawbars of Class e shall satisfy the tests given in paragraph 3.5 of annex 6.^[SP35]

5.2. In order to provide a connection to the towing vehicle, the drawbars can be fitted with either ball-shaped scrapers or coupling rings of Classes b, d or s. Ball-shaped scrapers and coupling rings can be attached by screwing, bolting or welding.

5.3. Height adjusting devices for hinged drawbars

5.3.1. Hinged drawbars shall be fitted with devices for adjusting the drawbar to the height of the coupling device or jaw. These devices shall be designed so that the drawbar can be adjusted by one person without tools or any other aids.

Draft: ECE-R XXX

Testing: Mechanical coupling devices for agricultural vehicles

Last updated: 21 July 2011

5.3.2. Height adjusting devices shall be able to adjust the coupling rings or ball-shaped scrapers 80 mm from the horizontal above the ground at least 300 mm upwards and downwards. Within this range the drawbar shall be adjustable steplessly, or in maximum steps of 50 mm measured at the coupling ring or ball-shaped scraper.^[SP36]

5.3.3. Height adjusting devices shall not interfere with the easy movement of the drawbar after coupling.

Note: Support devices for rigid drawbar trailers would need to be included here, as there is no annex 7.

5.4. The height adjusting devices shall not interfere with the action of any inertia, overrun type, brake.

5.5. In the case of drawbars combined with inertia, overrun, brakes, the distance between the centre of the coupling ring and the end of the free shank of the coupling ring shall not be less than 200 mm in the brake application position. With the shank of the coupling ring fully inserted the distance shall not be less than 150 mm.

5.6. Drawbars for use on centre axle trailers shall possess at least half the moment of resistance against lateral forces as against vertical forces.

5.7. Drawbars as defined in annex 5, paragraphs 2 and 4 shall be designed so that within the coupling point height specified by the manufacturer they have a maximum angle to the horizontal of $\pm 3^\circ$.

6 Towing brackets^[SP37]

6.1. Towing brackets of Class f shall satisfy the tests given in paragraph 3.6 of annex 6.

6.2. Towing brackets shall generally be installed on the vehicle's rear axle or transmission and are used to mount coupling devices of Classes a, c, g, h, j or s and any other mounted devices. Other mounted devices may include positive steering components, shank bearings, etc. which transmit additional forces to the towing bracket.^[SP38]

6.3. Towing brackets of Class f-1 with standard connections for standard quick height-adjustable latching rail plates of Classes a80-2 or c40-2 shall have the following principal dimensions:

Subclass	a Guide width in the towing bracket [mm]	b Pin diameter [mm]	c Latching rail guide width [mm]	d Guide depth [mm]
f-1.1	330	25	32	12 ^{±6}
f-1.2	336	22	30	12 ^{±6}
f-1.3	390	25	32	12 ^{±6}
f-1.4	200	22	30	12 ^{±6}

Draft: ECE-R XXX

Testing: Mechanical coupling devices for agricultural vehicles
Last updated: 21 July 2011

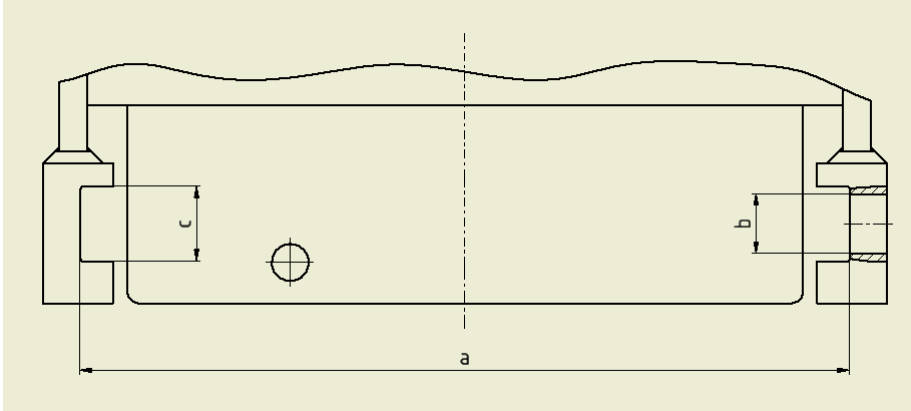

[SP39] Figure 25 – Principal dimensions of the qha towing bracket. The abbreviation qha should be added to the list of abbreviations.

Towing brackets of Class f-1 shall be designed to prevent the latching rail plate from slipping.
Note: numbering is missing

6.4 Towing brackets of Class f-2 shall be attached to the coupling devices using locking pins arranged at right angles to the direction of travel

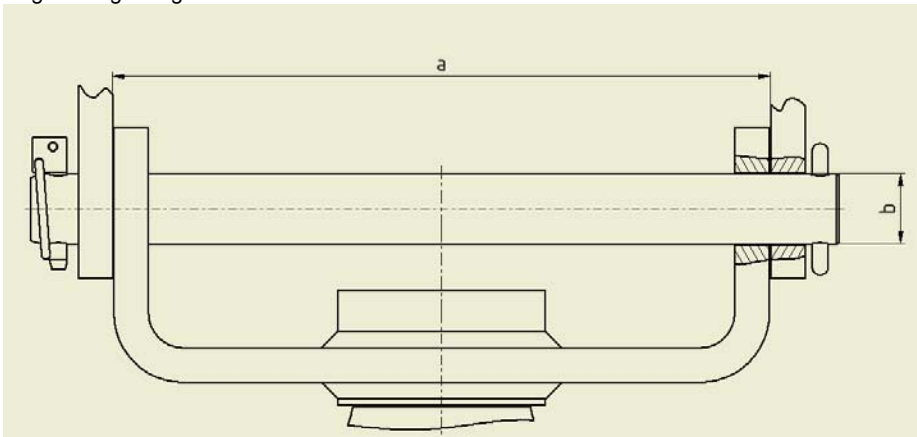

Figure 26 – Schematic diagram of the detachable towing bracket

6.5 Towing brackets of Class f-x encompass all towing brackets which cannot be assigned to Classes f-1 or f-2.

7 Hitch hooks and keeper plates

7.4 General requirements for hitch hooks [SP41]

All hitch hooks and keeper plates shall be designed such that hitch hooks satisfy the tests given in xx3.3.2 of annex 6 and keeper plates satisfy the tests given in xx3.3.5 of annex 6.

Hitch hooks of Class g shall conform to Figure 27 in external shape and external dimensions. The position of the keeper plate is shown in Figure 28.

Draft: ECE-R XXX

Testing: Mechanical coupling devices for agricultural vehicles
Last updated: 21 July 2011

Dimensions in millimetres

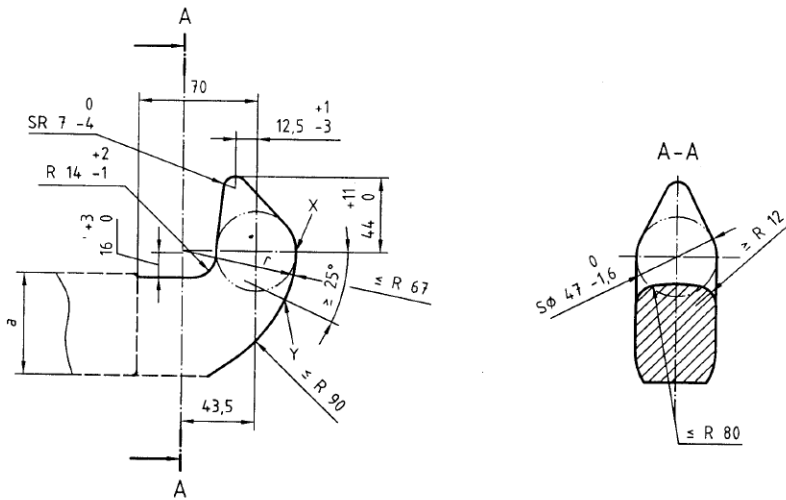

^a Not controlled.

Figure 27 – Principal dimensions of hitch hook

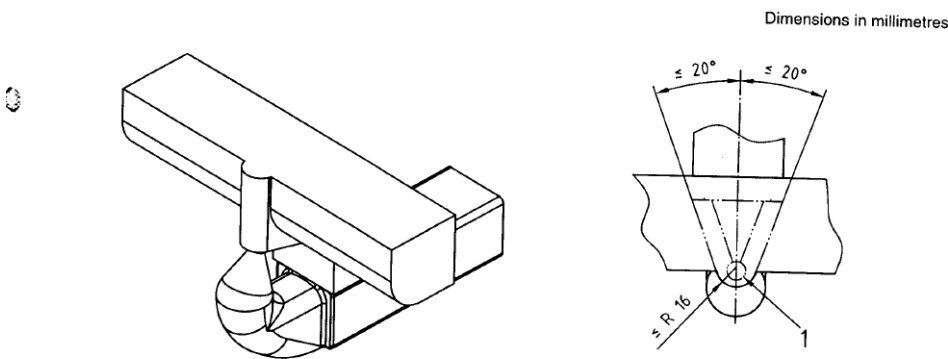

Key

- 1 Tip clearance for hook (if required)

Figure 28 – Position of the keeper plate

The hitch hook shall permit angles of articulation in accordance with 1.1.3.

8 Piton-type couplings and keeper plates

8.4 General requirements for piton-type couplings^[SP42]

All piton-type couplings and keeper plates shall be designed such that piton-type couplings satisfy the tests given in xx3.3.4 of annex 6 and keeper plates satisfy the tests given in xx3.3.5 of annex 6.

Draft: ECE-R XXX

Testing: Mechanical coupling devices for agricultural vehicles
Last updated: 21 July 2011

Piton-type couplings of Class h shall conform to Figure 29 in external shape and external dimensions. The position of the keeper plate is shown in Figure 30.

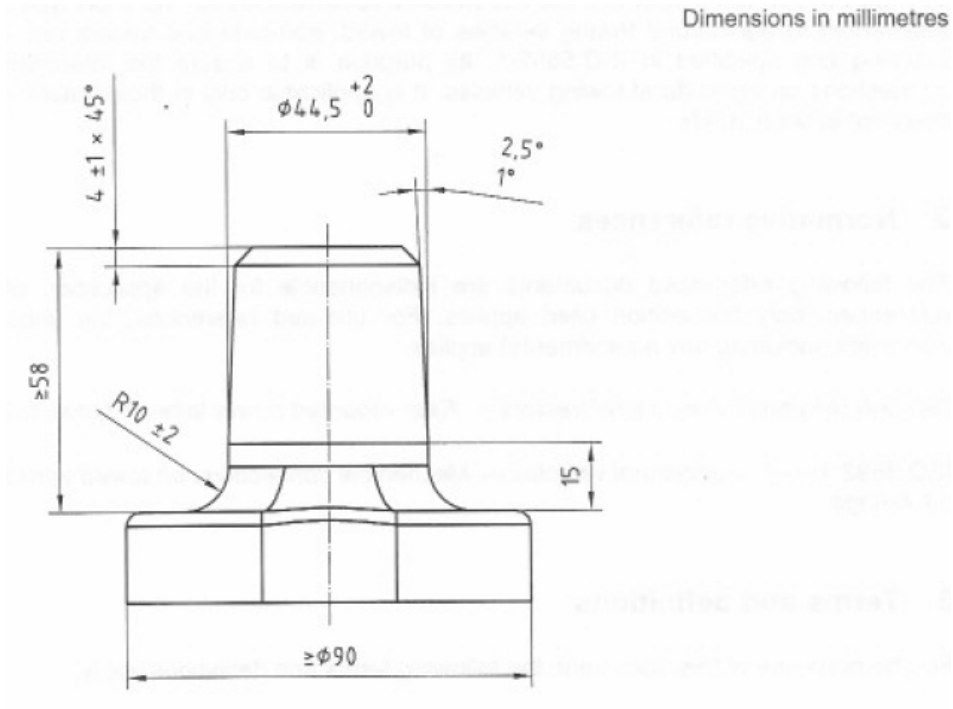

Figure 29 – Principal dimensions of the piton-type coupling

Draft: ECE-R XXX

Testing: Mechanical coupling devices for agricultural vehicles
Last updated: 21 July 2011

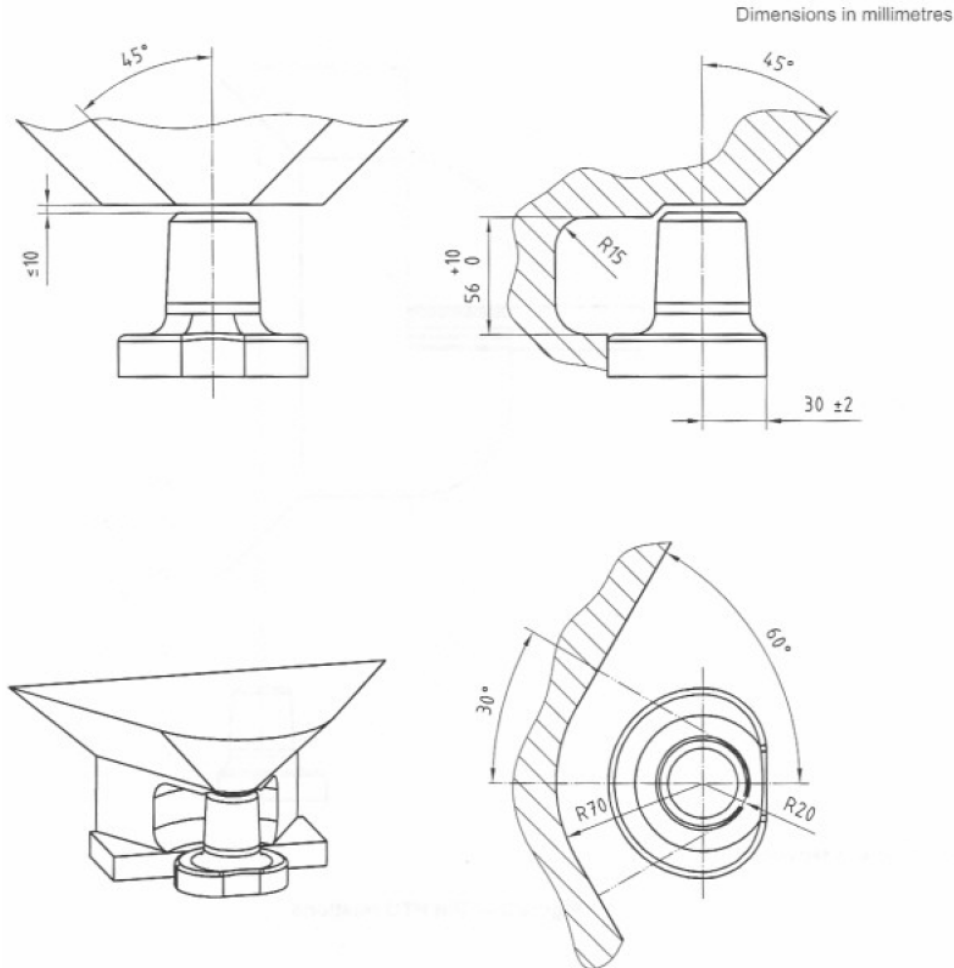

Figure 2 — Dimensions of keeper limiting surface (maximum metal)

Figure 30 – Position of the keeper plate

The piton-type coupling shall permit angles of articulation in accordance with 1.1.3.

9 Other coupling balls

9.4 The requirements and tests for coupling balls 80 of Class a shall be applied mutatis mutandis to coupling balls of Class j.

10 Other ball-shaped scrapers

10.4 The requirements and tests for ball-shaped scrapers 80 of Class b shall be applied mutatis mutandis to ball-shaped scrapers of Class k.

11 Coupling devices of Class s

Draft: **ECE-R XXX**

Testing: Mechanical coupling devices for agricultural vehicles

Last updated: 21 July 2011

11.4 For coupling devices of Class s, the relevant requirements in annexes 5 and 6 for the closest standard or non-standard device or component shall be used.

Annex 6

Testing of mechanical coupling devices for use on agricultural or forestry motor vehicles and on their trailers

1 General testing requirements

- 1.1 Samples of coupling devices shall be tested for both strength and function. With coupling devices the strength shall be verified by a dynamic test. In ^[SP43]certain cases additional static tests may be necessary (see paragraphs x3.3.5 and 3.5.3 of this annex) Note: perhaps omit this parenthesis entirely. The type approval authority or technical service may waive a dynamic or static test if the simple design of a component makes a theoretical check possible. Theoretical checks may also be carried out to determine worst case conditions. In all cases, theoretical checks shall ensure the same quality of results as with dynamic or static testing. In cases of doubt it is the results of physical testing that are overriding. (See also x.x of this Regulation.)
- 1.2 The dynamic test shall be performed with approximately sinusoidal load (alternating and/or pulsating) with a number of stress cycles appropriate to the material (2 M eielescycles for Steel and nodular cast iron). No cracks or fractures shall occur. Cracks of only minor significance are not taken into account.
- 1.3 Only slight permanent deformation is permitted with the static tests prescribed. Unless stated otherwise the permanent (plastic) deformation after releasing shall not be more than 10 per cent of the maximum deformation measured during the test.
- 1.4 The loading assumptions in the dynamic tests are based on the horizontal force component in the longitudinal axis of the vehicle and the vertical force component. Horizontal force components transverse to the longitudinal axis of the vehicle, and moments, are not taken into account provided they are of only minor significance. If the design of the coupling device or its attachment to the vehicle or the attachment of additional systems (such as equipment drives, force compensators, positive steering systems, etc.) generates additional forces or moments, these shall be taken into account during the tests. Additional tests may also be required by the type approval authority or technical service. The horizontal force component in the longitudinal axis of the vehicle is represented by a theoretically determined reference force, the ~~D~~-~~or~~-~~D_c~~ value. The vertical force component, where applicable, is represented by the static vertical bearing load, S, at the point of coupling and the assumed vertical force component, V_a.
- 1.5 The characteristic values D, ~~D_c~~ S and V_{max}, on which the tests are based and which are defined in paragraph 2.10 of this Regulation, shall be taken from the manufacturer's information given in the application for type approval – see communication form shown in annex 1.
- 1.6 Any positive locking device, which is retained in position by spring force, shall remain in its secured position when subjected to a force applied in the least favourable direction and equivalent to three times the mass of the locking mechanism.
- 1.7 The devices submitted for test shall be provided with all parts and design details which may have an influence on the strength characteristics (for example mounting plates, mounting brackets, screws).
- 1.8 If a worst case configuration can be defined by agreement between the manufacturer and the type approval authority or technical service, then testing of this one configuration alone shall be sufficient.
- Otherwise, several coupling device positions shall be tested.

2. Test procedures

Testing: Mechanical coupling devices for agricultural vehicles

Last updated: 21 July 2011

- 2.1 For the dynamic tests and static tests, the sample shall be placed in a suitable rig with a means of force application, such that it is not subjected to any additional forces or moments apart from the specified test force. In the case of alternating tests, the direction of force application shall not deviate by more than $\pm 1^\circ$ from the specified direction. In the case of pulsating and static tests, the angle shall be set for the maximum test force. This will normally require a joint at the point of force application (for example at the point of coupling) and a second joint a given distance away.
- 2.2 ~~The test frequency shall not exceed 25 Hz. The selected frequency shall be well separated from resonance frequencies of the test set up including the tested device. With asynchronous testing the frequencies of the two force components shall be between approximately 1 per cent and a maximum of 3 per cent apart. For coupling devices made from steel the number of stress cycles is 2×10^6 . For devices made from materials other than steel a higher number of cycles may be necessary. The dye penetration method of crack testing or an equivalent method shall be used to determine any cracking during test.~~
- 2.3 With pulsating tests, the test force varies between the maximum test force and a minimum test force, which may not be greater than 5 per cent of the maximum test force unless otherwise stated in the specific testing procedure.
- 2.4 With static tests the test force shall be applied smoothly and quickly and be maintained for at least 60 seconds.
- 2.5 The coupling devices or components on test should normally be mounted as rigidly as possible on a test rig in the position in which they will be used on the vehicle. The fixing devices should be those specified by the manufacturer or applicant and should be those intended for the attachment of the coupling device or component to the vehicle and/or shall have identical mechanical characteristics.
- 2.6 Coupling devices or components shall be tested in the form used on the road. However, at the discretion of the manufacturer, and in agreement with the technical service, flexible components may be clamped if this is necessary for the test procedure and if this will not have any unrealistic influence on the test result. Flexible components which are overheated during these accelerated test procedures may be replaced during the test. The test loads may be applied by means of special slack-free devices.
- 2.7 The test requirements defined in this annex shall apply mutatis mutandis to all other coupling devices (Class s).
- 2.8 If the resultant angle of test for a test force for a coupling device is large (e.g. for towing balls 110), to ensure the feasibility of the test, the technical service may specify a two-component synchronous test.

3. Specific testing requirements

Coupling devices for [axle loads of trailer with total mass of](#) up to 3.5 t shall be tested in accordance with the requirements of ECE R55 (as last amended).

- 3.1 Coupling balls 80 (Class a)
- 3.1.1 The basic test is a dynamic endurance test. The test sample comprises the coupling ball and the mountings necessary for attaching the assembly to the vehicle. The coupling ball shall be rigidly mounted to a test rig, capable of producing an alternating or pulsating force, in the actual position in which it is intended for use.
- 3.1.2 A suitable ball-shaped scraper 80 shall be used as a means of force application. The sample shall be mounted on the test rig with the coupling elements applied for and arranged such that its relative position corresponds to that of the intended use. The sample shall not be subjected to any additional forces or moments apart from the test force. The test force shall be applied along a line of action through the point of coupling, directed at a resultant angle derived from

Draft: **ECE-R XXX**

Testing: Mechanical coupling devices for agricultural vehicles
Last updated: 21 July 2011
the horizontal and vertical loading assumptions.

3.1.3 Loading assumptions

Synchronous pulsating dynamic endurance test with resultant test force

$$F_{hsres} = \sqrt{F_h^2 + F_s^2}$$

$$\alpha = \arctan \frac{F_s}{F_h}$$

within the range for tensile or compressive pulsating stresses (whichever is the greater)

where

$$F_{h\ sch} = 1.0 \cdot D_e$$

$$F_{s\ sch} = g \cdot S + 0.24 \cdot D_e \text{ but at least } F_{s\ sch} = 0.4 \cdot D_e$$

$$F_{g\ sch} = gS + 0.3V$$

Alternatively, a two-component synchronous dynamic endurance test is also permissible. This is recommended in particular where the angle of the resultant is large. Over the permissible angle allowed by the combination of towing devices^[SP46]

Test forces for S = 0 are lacking.

3.2 Ball-shaped scrapers 80 (Class b)

3.2.1 The basic test is a dynamic endurance test in which an alternating or pulsating test force is applied.

3.2.2 The dynamic test shall be performed using a separate assembly with a coupling ball 80 of an equivalent or higher strength.

The sample shall be mounted on the test rig with the coupling elements applied for and arranged such that its relative position corresponds to that of the intended use.

The sample shall not be subjected to any additional forces or moments apart from the test force.

The test force shall be applied along a line of action through the point of coupling, directed at a resultant angle derived from the horizontal and vertical loading assumptions.

3.2.3 Loading assumptions

as in 3.1.3 of this annex (coupling balls 80)

3.3. ~~Trailer~~ couplings^[SP47]^[SP48]

3.3.1 Clevis-type couplings (Class c)

A dynamic endurance test shall be carried out on a sample. The coupling device shall be equipped with all the fixings needed to attach it to the vehicle.

3.3.1.1 for rigid drawbar trailers.

as in 3.1.3 of this annex

Draft: **ECE-R XXX**

Testing: Mechanical coupling devices for agricultural vehicles

Last updated: 21 July 2011

~~Synchronous dynamic endurance test within the range for pulsating tensile stresses with resultant test force (direction of pull rearwards and down)~~

$$F_{\text{resultant}} = \sqrt{F_h^2 + F_s^2}$$

Draft: ECE-R XXX

Testing: Mechanical coupling devices for agricultural vehicles
Last updated: 21 July 2011

$$\alpha = \arctan \frac{F_v}{F_h}$$

where:

$$F_{h-sch} = 1.0 \cdot D_e$$
$$F_{v-sch} = S \cdot g + 0.24 \cdot D_{et}, \text{ but at least } F_{v-sch} = 0.4 \cdot D_e$$

~~Add an extra point for articulated drawbar/full trailers or amend point 3.3.1.4~~

~~Special case: For articulated drawbar trailers, $F_{v-sch} = 0$~~

~~alternatively:~~

~~Asynchronous dynamic endurance test (2-component) with test forces as defined in R55-annex 6, number 3.3 (as last amended)~~

3.3.1.2 Clevis-type couplings on trailers: What formula is applicable in this case for clevis-type couplings with vertical load? Should be discussed with Mr Conrads and Mr Graser

~~Combination of maximum 2 trailers~~

~~Loading assumptions taking into account the D value~~

$$D = g \frac{(T + R_1) - R_2}{(T + R_1) + R_2}$$

~~R_1 and R_2 as specified by the manufacturer ($R_2 \leq R_1$) or $T + R_1$ (largest value) = 40 t - R_2 . If the above formula is used, these condition are unnecessary. Only if (see TA31):~~

$$D = g \frac{R_1 - R_2}{R_1 + R_2} \text{ is used.}$$

$$D = g R 0.5 \text{ (p49)6}$$

Dynamic endurance tests as in 3.3.1.2.

3.3.1.3 Static tests on locking device for coupling pin

With clevis-type couplings with non-cylindrical pins, it is also necessary to test the closure and any locking devices by means of a static force of 0.25 D acting in the direction of opening.

A test force of 0.1 D is sufficient in the case of cylindrical coupling pins.

This force shall be raised to the above value smoothly and quickly and be maintained for 10 seconds.

The test shall not cause the closure to open and it shall not cause any damage.

3.3.2 Hitch hooks (Class g)

as in 3.1.3 of this annex (clevis-type couplings)

3.3.3 Tractor drawbars (Class s)

Draft: **ECE-R XXX**

Testing: Mechanical coupling devices for agricultural vehicles
Last updated: 21 July 2011
as in 3.1.3 of this annex (clevis-type couplings)

Draft: ECE-R XXX

Testing: Mechanical coupling devices for agricultural vehicles

Last updated: 21 July 2011

3.3.4 Piton-type couplings (Class h)

as in 3.1.3 of this annex (clevis-type couplings)

3.3.5 Keeper plates (for all trailer couplings of **Classes a, g and h**, where present)

For ball, hook and piton-type couplings and equivalent devices, the keeper plate shall be tested using a static force of $F_{s \text{ stat}} = 0.6 \cdot D$ [SP50] (vertically upwards). The coupling rings may not be released and no permanent deformation which would be detrimental to the satisfactory operation of the device is permitted.

3.4 Coupling rings (**Classes d and s**)

3.4.1 Coupling rings (Classes d1 and d2) for clevis-type couplings shall be subjected to the same dynamic tests and equivalent loading assumptions (see 3.3.1).

For coupling rings which are used exclusively on articulated drawbar trailers, a test using the horizontal loading assumptions shall be performed.

The test may be performed applying either an alternating or a pulsating test force as specified in 3.3.1.

3.4.2 Hitch rings (**Classes d3 and d4**) for hitch hooks, tractor drawbars or piton-type couplings shall be tested in the same way as coupling rings for clevis-type couplings.

3.4.3 The test procedure for testing coupling rings shall be carried out such that the test force is also applied to those parts with which the coupling rings are attached to the drawbar. All flexible intermediate components shall be clamped.

3.5 **Drawbars** [SP51]

3.5.1 Drawbars shall be tested in the same way as coupling rings (see 3.4). The type approval authority or technical service may waive an endurance test if the simple design of a component makes a theoretical check possible.

~~Synchronous dynamic endurance test with resultant test force~~

$$F_{\text{resultant}} = \sqrt{F_h^2 + F_s^2}$$

$$\alpha = \arctan \frac{F_s}{F_h}$$

~~a) within the range of alternating tensile-compressive stresses~~

$$F_{\text{hw}} = \pm 0.6 \cdot D$$

$$F_{\text{sw}} = \pm 0.6 \cdot (g \cdot S + V_a \cdot d)$$

~~or, if the alternating test cannot be performed satisfactorily due to the design of the trailer coupling:~~

~~b) within the range for tensile or compressive pulsating stresses (whichever is the greater)~~

$$F_{\text{t-sch}} = 1.0 \cdot D$$

$$F_{\text{s-sch}} = 1.0 \cdot (g \cdot S + V_a \cdot d)$$

~~alternatively:~~

~~Asynchronous dynamic endurance test (2-component) with resultant test forces~~

Draft: ECE-R XXX

Testing: Mechanical coupling devices for agricultural vehicles

Last updated: 21 July 2011

$$F_{hw} = \pm 0.6 \cdot D$$
$$F_{sw} = g \cdot S \pm 0.6 \cdot V_a \cdot d$$

where: $d = 0.8 - 1.0$ interpolated linearly for 40 to 80 km/h

3.5.2 For drawbars for full trailers with free movement in the vertical plane, in addition to the endurance test or theoretical check of strength, the resistance to buckling shall be verified by a theoretical calculation.

See annex 6 appendix 2.

The permissible stresses to be considered in the case of calculation shall be in accordance with paragraph 5.3 of ISO 7641-1:1983.

3.5.3 In the case of steered axles, the resistance to bending shall be verified by theoretical calculations or by a bending test. A horizontal, lateral static force shall be applied in the centre of the coupling point. The magnitude of this force shall be chosen so that a moment of $0.3 \times AV \times g$ (kNm) is exerted about the front axle centre. The permissible stresses shall be in accordance with paragraph 5.3 of ISO 7641-1:1983. However, in the case where the steered axles form a steered axle subframe (steered bogie), the moment shall be increased to $0.95 \times AV \times g$ (kNm).

3.6 Towing brackets (Class f)

3.6.1 Towing brackets shall be subjected to the same forces during testing as the coupling. The test load shall be applied at a horizontal and vertical distance corresponding to the position of the coupling device which exerts the least favourable load on the towing bracket.

3.6.2 [This point is in contradiction with point 1.4 of this annex must be discussed with technical services benefits and experiences on this kind of test.](#)

Towing brackets with connections for a quick height-adjustable latching rail plate on the point of coupling side shall be subject to a static test in the transverse direction.

Force $[0.6 \cdot D]$

Angle of application $[60^\circ$ to the longitudinal centre line]

Point of force application to the coupling point see 3.6.1

The guide width in the qha towing bracket when loaded shall not deform by more than 1 per cent and the trailer coupling shall not separate from the towing bracket.

3.7 Coupling balls (Class j) [why a similar kind of test on ball coupling? We have already defined a test for ball couplings in point 3](#)

The D value for testing coupling balls of Class j and the vertical load S as specified by the manufacturer shall be the characteristic values for the load assumptions in accordance with 3.1 of this annex.

If the resultant angle of test, α , derived from these load assumptions is greater than 25° , an asynchronous dynamic endurance test (2-component) shall be performed,

where:

$$F_{hw} = \pm 0.6 \cdot D$$
$$F_{sO} = g \cdot 1.2 \cdot S$$
$$F_{sU} = g \cdot 0.4 \cdot S$$

Draft: **ECE-R XXX**

Testing: Mechanical coupling devices for agricultural vehicles

Last updated: 21 July 2011

If a coupling ball of Class j incorporates a locking mechanism or keeper plate, a static separation test as defined in annex 6 paragraph 3.2 shall be performed on this device.

Draft: **ECE-R XXX**

Testing: Mechanical coupling devices for agricultural vehicles
Last updated: 21 July 2011

3.8 Ball-shaped scrapers (Class k)^[SP52]

Ball-shaped scrapers shall be tested in accordance with 3.7 of this annex.

Draft: ECE-R XXX

Testing: Mechanical coupling devices for agricultural vehicles
Ust updated 21 July 2011

[No more necessary](#)

- Anlage 3 -
[SP53]

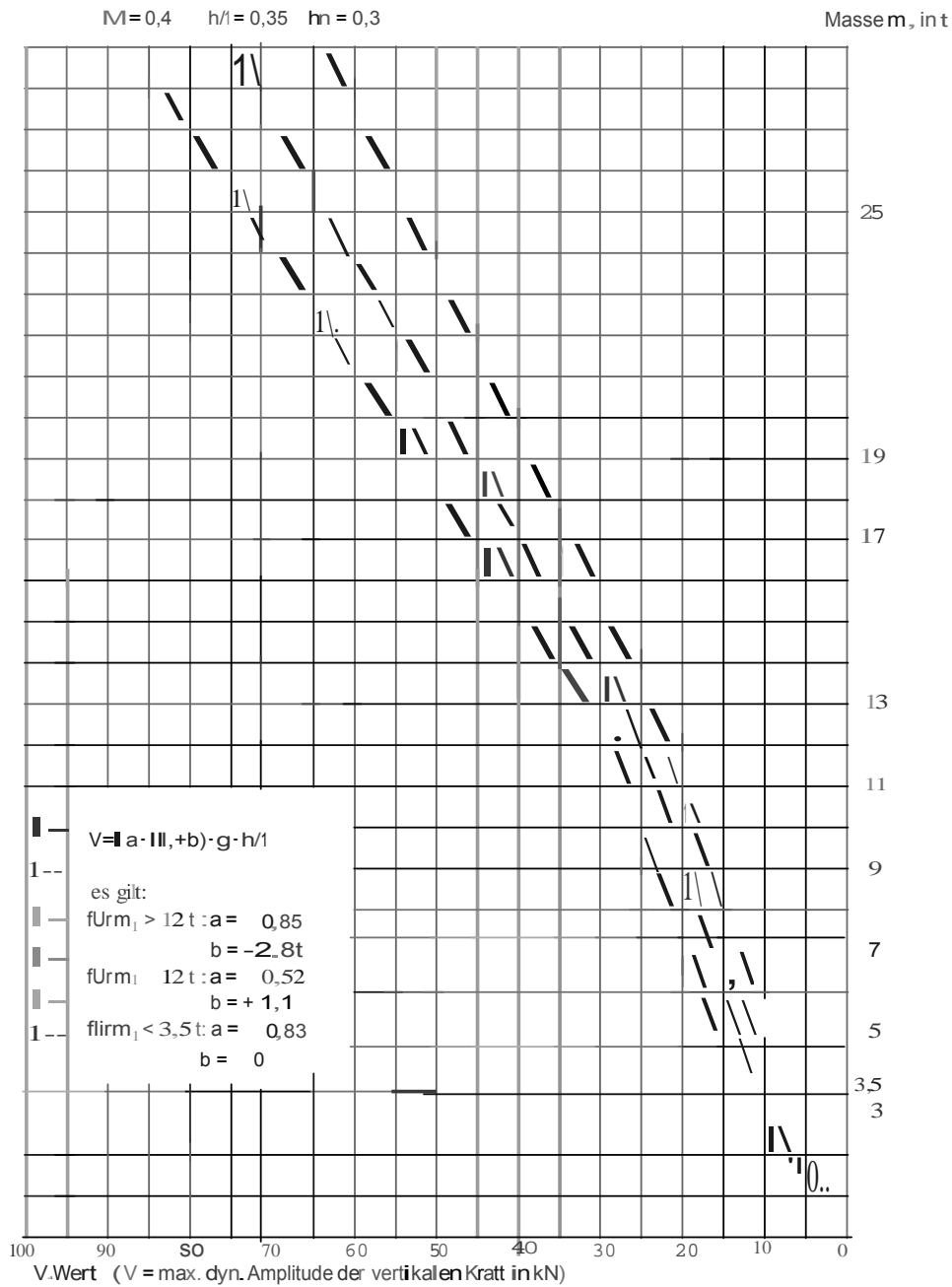

Bemerkung: oh.ne besondere Antragsstellung wr rd fir Anh8rger unterstellt: $h/l = 0,4$